



RADIATED SPURIOUS EMISSIONS PORTIONS OF

**FCC CFR47 PART 22 SUBPART H
FCC CFR47 PART 24 SUBPART E
INDUSTRY CANADA RSS-132 ISSUE 2
INDUSTRY CANADA RSS-133 ISSUE 5**

CERTIFICATION TEST REPORT

FOR

INTERNET EVERYTHING MODULE

MODEL: IEM6085

**FCC ID: J9CIEMEVD0
IC: 2723A-IEMEVD0**

REPORT NUMBER: 10U13553-1, Revision D

ISSUE DATE: FEBRUARY 16, 2011

Prepared for

**QUALCOMM INCORPORATED
5775 MOREHOUSE DRIVE
SAN DIEGO, CA 92121, U.S.A.**

Prepared by

**COMPLIANCE CERTIFICATION SERVICES (UL CCS)
47173 BENICIA STREET
FREMONT, CA 94538, U.S.A.
TEL: (510) 771-1000
FAX: (510) 661-0888**



NVLAP LAB CODE 200065-0

Revision History

<u>Rev.</u>	<u>Issue Date</u>	<u>Revisions</u>	<u>Revised By</u>
---	12/27/10	Initial Issue	T. Chan
A	01/18/11	Revised model number	A. Zaffar
B	01/21/11	Revised FCC ID and Model number	A. Zaffar
C	02/07/11	Added maximum antenna gain to report	A. Zaffar
D	02/16/11	Revised maximum antenna gain	A. Zaffar

TABLE OF CONTENTS

1. ATTESTATION OF TEST RESULTS	4
2. TEST METHODOLOGY	5
3. FACILITIES AND ACCREDITATION	5
4. CALIBRATION AND UNCERTAINTY	5
4.1. <i>MEASURING INSTRUMENT CALIBRATION</i>	5
4.2. <i>SAMPLE CALCULATION</i>	5
4.3. <i>MEASUREMENT UNCERTAINTY</i>	5
5. EQUIPMENT UNDER TEST	6
5.1. <i>DESCRIPTION OF EUT</i>	6
5.2. <i>MAXIMUM OUTPUT POWER</i>	6
5.3. <i>SOFTWARE AND FIRMWARE</i>	8
5.4. <i>WORST-CASE CONFIGURATION AND MODE</i>	8
5.5. <i>DESCRIPTION OF TEST SETUP</i>	10
6. TEST AND MEASUREMENT EQUIPMENT	12
7. LIMITS AND RESULTS	13
7.1. <i>RADIATED OUTPUT POWER</i>	13
7.2. <i>FIELD STRENGTH OF SPURIOUS RADIATION</i>	18
7.3. <i>RECEIVER SPURIOUS EMISSIONS</i>	23
8. SETUP PHOTOS	28

1. ATTESTATION OF TEST RESULTS

COMPANY NAME: QUALCOMM INCORPORATED
5775 MOREHOUSE DRIVE
SAN DIEGO, CA 92121, U.S.A.

EUT DESCRIPTION: INTERNET EVERYTHING MODULE

MODEL: IEM6085

SERIAL NUMBER: N10F9CGV1 (RADIO MODULE),
N10F9M4WR (WHOLE SYSTEM)

DATE TESTED: DECEMBER 14 TO 23, 2010

APPLICABLE STANDARDS	
STANDARD	TEST RESULTS
FCC PART 22H & 24E	PASS (Radiated Portion)
IC RSS-132 ISSUE 2 & RSS-133 ISSUE 5	PASS (Radiated Portion)

Compliance Certification Services, Inc. (UL CCS) tested the above equipment in accordance with the requirements set forth in the above standards. All indications of Pass/Fail in this report are opinions expressed by UL CCS based on interpretations and/or observations of test results. Measurement Uncertainties were not taken into account and are published for informational purposes only. The test results show that the equipment tested is capable of demonstrating compliance with the requirements as documented in this report.

Note: The results documented in this report apply only to the tested sample, under the conditions and modes of operation as described herein. This document may not be altered or revised in any way unless done so by UL CCS and all revisions are duly noted in the revisions section. Any alteration of this document not carried out by UL CCS will constitute fraud and shall nullify the document. No part of this report may be used to claim product certification, approval, or endorsement by NVLAP, NIST, or any government agency.

Approved & Released For CCS By:

Tested By:

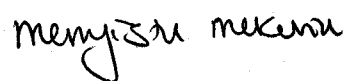

THU CHAN
ENGINEERING MANAGER
UL CCS

MENGISTU MEKURIA
EMC ENGINEER
UL CCS

2. TEST METHODOLOGY

The tests documented in this report were performed in accordance with TIA-603-C, FCC CFR 47 Part 2, FCC CFR 47 Part 22, FCC CFR Part 24, FCC Part 27, RSS-132 Issue 2, RSS-133 Issue 5 and RSS-139 Issue 2.

3. FACILITIES AND ACCREDITATION

The test sites and measurement facilities used to collect data are located at 47173 Benicia Street, Fremont, California, USA.

UL CCS is accredited by NVLAP, Laboratory Code 200065-0. The full scope of accreditation can be viewed at <http://www.ccsemc.com>.

4. CALIBRATION AND UNCERTAINTY

4.1. MEASURING INSTRUMENT CALIBRATION

The measuring equipment utilized to perform the tests documented in this report has been calibrated in accordance with the manufacturer's recommendations, and is traceable to recognized national standards.

4.2. SAMPLE CALCULATION

Where relevant, the following sample calculation is provided:

$$\text{Field Strength (dBuV/m)} = \text{Measured Voltage (dBuV)} + \text{Antenna Factor (dB/m)} + \text{Cable Loss (dB)} - \text{Preamp Gain (dB)}$$

$$36.5 \text{ dBuV} + 18.7 \text{ dB/m} + 0.6 \text{ dB} - 26.9 \text{ dB} = 28.9 \text{ dBuV/m}$$

4.3. MEASUREMENT UNCERTAINTY

Where relevant, the following measurement uncertainty levels have been estimated for tests performed on the apparatus:

PARAMETER	UNCERTAINTY
Conducted Disturbance, 0.15 to 30 MHz	3.52 dB
Radiated Disturbance, 30 to 1000 MHz	4.94 dB

Uncertainty figures are valid to a confidence level of 95%.

5. EQUIPMENT UNDER TEST

5.1. DESCRIPTION OF EUT

The Internet of Everything Module (IEM) 1x/EVDO is an ultra small, 21 x 22 x 4.4 mm WWAN module that can be integrated into a multitude of host devices. The IEM 1x/EVDO module operates on the 800/1900 MHz CDMA2000 1x/EVDO networks. The module uses Qualcomm's QSC 6085 chip set and has stand alone GPS, AGPS, gpsOneXTRA-tm and Bluetooth 2.0 technologies. Interfaces for the module include USB 2.0, Bluetooth 2.0, I2C, RUIM support, LCD, camera, keypad, 2 LED control lines, vibrator control, audio and primary RF coax. The IEM design is optimized for minimal cost, minimal size, maximum battery life and superb position location performance. The IEM 1x/EVDO device meets the following standards: IS-2000 for CDMA 1xRTT, IS-856 Release A for 1xEV-DO, IS-707-A Data, IS-637-B SMS, IS-683-A Service provisioning, gpsOne and IS-98 CDMA Minimum Performance.

Only 850 MHz (Cellular) and 1900 MHz (PCS) bands are used for operation. The DUT is a pre-production sample.

5.2. MAXIMUM OUTPUT POWER

Maximum antenna gain (including cable loss):

-Cellular band < 3dBi

-PC band < 3 dBi

The transmitter has maximum, peak ERP for all modes, average EIRP output powers as follow:

1xRTT CDMA MODE

824 to 849 MHz Authorized Band

Frequency Range (MHz)	Modulation	ERP Output Power (dBm)	ERP Output Power (mW)
Low CH - 824.70	1xRTT CDMA2000	27.3	537.0
Mid CH - 836.52		26.8	478.6
High CH - 848.31		26.2	416.9

1850 to 1910 MHz Authorized Band

Frequency Range (MHz)	Modulation	EIRP Output Power (dBm)	EIRP Output Power (mW)
Low CH - 1851.25	1xRTT CDMA2000	23.9	245.5
Mid CH - 1880.00		23.7	234.4
High CH - 1908.75		22.9	195.0

EVDO REV. A CDMA MODE

824 to 849 MHz Authorized Band

Frequency Range (MHz)	Modulation	ERP Output Power (dBm)	ERP Output Power (mW)
Low CH - 824.70	EVDO REV. A CDMA	28.2	660.7
Mid CH - 836.52		26.0	398.1
High CH - 848.31		24.9	309.0

1850 to 1910 MHz Authorized Band

Frequency Range (MHz)	Modulation	EIRP Output Power (dBm)	EIRP Output Power (mW)
Low CH - 1851.25	EVDO REV. A CDMA	23.7	234.4
Mid CH - 1880.00		22.9	195.0
High CH - 1908.75		23.4	218.8

5.3. SOFTWARE AND FIRMWARE

The EUT is linked with Agilent Communication Test Set. The software loaded is Q6085BSNAYAZW53905.

5.4. WORST-CASE CONFIGURATION AND MODE

The worst-case was EUT with highest emissions. Based on conducted output power measurements 1xRTT and EVDO REV A have been chosen as worst-case.

PROCEDURE USED TO ESTABLISH TEST SIGNAL

3G-CDMA2000 1xRTT

This procedure assumes the Agilent 8960 Test Set has the following applications installed and with valid license.

<u>Application</u>	<u>Rev, License</u>
CDMA2000 Mobil Test	B.10.11, L

1xRTT

- Call Setup > Shift & Preset
- Protocol Rev > 6 (IS-2000-0)
- Radio Config (RC) > RC2 (Fwd2, Rvs2)
- FCH Service Option (SO) Setup > 55
- Traffic Data Rate > Full
- TDSO SCH Info > F-SCH Parameters > F-SCH Data Rate > 153.6 kbps
> R-SCH Parameters > R-SCH Data Rate > 153.6 kbps
- Cell Info > Cell Parameters > System ID (SID) > 331
> Network ID (NID) > 1

Once "Active Cell" show "Connected " then change "Rvs Power Ctrl" from "Active bits" to "**All Up bits**" to get the maximum power.

Worst-case Measurement Result @ Low, Middle and High Channel

Worst-case Measurement Result for Low, Middle and High Channel under Radio Configuration RC2 and Service Option 55.

CDMA2000 EVDO REV A.

This procedure assumes the Agilent 8960 Test Set has the following applications installed and with valid license.

<u>Application</u>	<u>Rev, License</u>
1xEV-DO Terminal Test	A.09.13

EVDO Rev. A – RETAP

- Call Setup > Shift & Preset
- Cell Power > -60 dBm/1.23 MHz
- Protocol Rev > A (1xEV-DO-A)
- Application Config > Enhanced Test Application Protocol > RETAP
- R-Data Pkt Size > 1536
- Protocol Subtype Config > Release A Physical Layer Subtype > Subtype 2
- > PL Subtype 2 Access Channel MAC Subtype > Default (Subtype 0)
- Access Network Info > Cell Parameters > Sector ID > 00000000: 00000000: 00000000: 00000000 > Subnet Mask > 0
- Generator Info > Termination Parameters > Max Forward Packet Duration > 16 Slots > ACK R-Data After > Subpacket 0 (All ACK)
- Rvs Power Ctrl > All Up bits (to get the maximum power)

EVDO Rev. A - FETAP

- Call Setup > Shift & Preset
- Cell Power > -60 dBm/1.23 MHz
- Protocol Rev > A (1xEV-DO-A)
- Application Config > Enhanced Test Application Protocol > FETAP
- F-Traffic Format > 4 (1024, 2,128) Canonical (307.2k, QPSK)
- Protocol Subtype Config > Release A Physical Layer Subtype > Subtype 2
- > PL Subtype 2 Access Channel MAC Subtype > Default (Subtype 0)
- Access Network Info > Cell Parameters > Sector ID > 00000000: 00000000: 00000000: 00000000 > Subnet Mask > 0
- Generator Info > Termination Parameters > Max Forward Packet Duration > 16 Slots > ACK R-Data After > Subpacket 0 (All ACK)
- Rvs Power Ctrl > All Up bits (to get the maximum power)

5.5. DESCRIPTION OF TEST SETUP

SUPPORT EQUIPMENT

PERIPHERAL SUPPORT EQUIPMENT LIST				
Description	Manufacturer	Model	Serial Number	FCC ID
DC Power Supply	Agilent / HP	6296A	2410A05117	DoC

I/O CABLES

I/O CABLE LIST						
Cable No.	Port	# of Identical Ports	Connector Type	Cable Type	Cable Length	Remarks
1	DC Input	1	DC	Un-Shielded	0.8 m	N/A
2	Antenna	1	SMK	Shielded	3.0 m	N/A

TEST SETUP

The EUT is a PCI express mini card that attached to test Jig which powered from AC Adapter. Communications Test Set is used to link the device under test.

SETUP DIAGRAM FOR TESTS

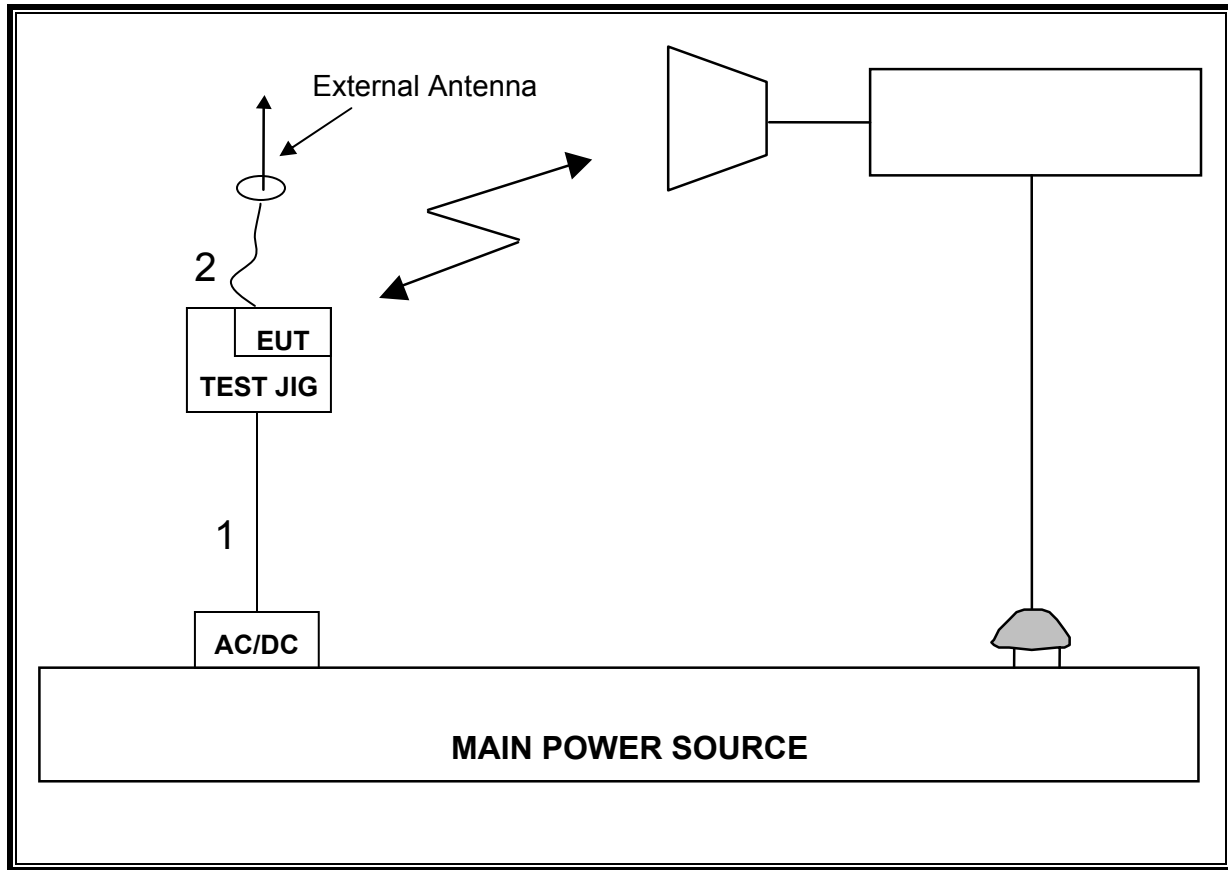

6. TEST AND MEASUREMENT EQUIPMENT

The following test and measurement equipment was utilized for the tests documented in this report:

TEST EQUIPMENT LIST				
Description	Manufacturer	Model	Asset	Cal Due
Spectrum Analyzer, 44 GHz	Agilent / HP	E4446A	C01069	03/05/11
Communications Test Set	Agilent / HP	E5515C	C01086	06/17/11
Preamplifier, 1300 MHz	Agilent / HP	8447D	C00885	01/06/11
Preamplifier, 26.5 GHz	Agilent / HP	8449B	C01052	07/14/11
Dipole	Speag	D900V2	N/A	11/16/11
Highpass Filter, 1.5 GHz	Micro-Tronics	HPM13193	N02689	CNR
Highpass Filter, 2.7 GHz	Micro-Tronics	HPM13194	N02687	CNR
Signal Generator	R & S	SMP04	C00953	02/16/11
Antenna, Horn, 18 GHz	EMCO	3115	C00943	CNR
Antenna, Horn, 18 GHz	EMCO	3115	C00945	06/29/11
Antenna, Bilog, 2 GHz	Sunol Sciences	JB1	C01011	07/12/11

7. LIMITS AND RESULTS

7.1. RADIATED OUTPUT POWER

LIMITS

22.913(a) The ERP of mobile transmitters and auxiliary test transmitters must not exceed 7 Watts.

24.232(b) & RSS133 § 6.4 Mobile/portable stations are limited to 2 watts e.i.r.p. peak power and the equipment must employ means to limit the power to the minimum necessary for successful communications.

RSS-132 § 4.4 The maximum ERP shall be 6.3 Watts for mobile stations.

TEST PROCEDURE

ANSI / TIA / EIA 603 Clause 2.2.17, RSS-132 & RSS-133

This section reports the maximum instantaneous peak ERP of the intentional transmitter using a peak detector per Part 22 measurement detector settings, and the maximum average EIRP of the intentional transmitter using an average detector per Part 24 measurement detector settings. The maximum instantaneous peak ERP can be expected to be different from the maximum average conducted power plus the antenna gain in dBd.

RESULTS

1xRTT CDMA

CELL OUTPUT POWER (ERP)

High Frequency Substitution Measurement Compliance Certification Services Chamber A							
Company:	QUALCOMM						
Project #:	10U13553						
Date:	12/14/2010						
Test Engineer:	MENGISTU MEKURIA						
Configuration:	EUT WITH EXTERNAL ANTENNA						
Mode:	TX, 1xRTT CELL BAND						
Test Equipment:							
Receiving: Sunlo T122, and 3m Chamber N-type Cable (Setup this one for testing EUT)							
Substitution: Dipole S/N: 00022117, 6ft SMA Cable (SN # 208947003) Warehouse.							
f MHz	SA reading (dBm)	Ant. Pol. (H/V)	Path Loss (dBm)	ERP (dBm)	Limit (dBm)	Margin (dB)	Notes
824.70	-7.5	V	34.8	27.3	38.5	-11.2	
824.70	-14.6	H	30.5	15.9	38.5	-22.5	
836.52	-6.4	V	33.1	26.8	38.5	-11.7	
836.52	-14.5	H	31.2	16.7	38.5	-21.7	
848.31	-6.0	V	32.1	26.2	38.5	-12.3	
848.31	-15.7	H	31.2	15.6	38.5	-22.9	
Rev. 1.24.7							

PCS OUTPUT POWER (EIRP)

High Frequency Fundamental Measurement Compliance Certification Services Chamber A							
Company:		QUALCOMM					
Project #:		10U13553					
Date:		12/14/2010					
Test Engineer:		MENGISTU MEKURIA					
Configuration:		EUT WITH EXTERNAL ANTENNA					
Mode:		TX, 1xRTT PCS BAND					
Test Equipment:							
Receiving: Horn T73, and Camber B SMA Cables							
Substitution: Horn T72 Substitution, 6ft SMA Cable (208947003) Warehouse							
f GHz	SA reading (dBm)	Ant. Pol. (H/V)	Path Loss (dBm)	EIRP (dBm)	Limit (dBm)	Delta (dB)	Notes
1.851	-16.6	V	40.4	23.9	33.0	-9.2	
1.851	-27.8	H	39.7	11.9	33.0	-21.1	
1.880	-16.2	V	39.9	23.7	33.0	-9.3	
1.880	-26.5	H	40.1	13.6	33.0	-19.4	
1.909	-16.9	V	39.8	22.9	33.0	-10.1	
1.909	-27.1	H	40.2	13.1	33.0	-19.9	
Rev. 1.24.7							

EVDO REV A CDMA

CELL OUTPUT POWER (ERP)

High Frequency Substitution Measurement Compliance Certification Services Chamber A							
Company:		QUALCOMM					
Project #:		10U13553					
Date:		12/22/2010					
Test Engineer:		MENGISTU MEKURIA					
Configuration:		EUT WITH EXTERNAL ANTENNA					
Mode:		TX, EVDO REV. A CELL BAND					
Test Equipment:							
Receiving: Sunol T122, and 3m Chamber N-type Cable (Setup this one for testing EUT)							
Substitution: Dipole S/N: 00022117, 6ft SMA Cable (SN # 208947003) Warehouse.							
f MHz	SA reading (dBm)	Ant. Pol. (H/V)	Path Loss (dBm)	ERP (dBm)	Limit (dBm)	Margin (dB)	Notes
824.70	-6.6	V	34.8	28.2	38.5	-10.3	
824.70	-12.5	H	30.5	18.1	38.5	-20.4	
836.52	-7.1	V	33.1	26.0	38.5	-12.4	
836.52	-12.9	H	31.2	18.3	38.5	-20.1	
848.31	-7.2	V	32.1	24.9	38.5	-13.5	
848.31	-13.3	H	31.2	17.9	38.5	-20.5	
Rev. 1.24.7							

PCS OUTPUT POWER (EIRP)

High Frequency Fundamental Measurement Compliance Certification Services Chamber A							
Company:		QUALCOMM					
Project #:		10U13553					
Date:		12/22/2010					
Test Engineer:		MENGISTU MEKURIA					
Configuration:		EUT WITH EXTERNAL ANTENNA					
Mode:		TX, EVDO REV. A PCS BAND					
<u>Test Equipment:</u>							
Receiving: Horn T73, and Camber B SMA Cables							
Substitution: Horn T72 Substitution, 6ft SMA Cable (208947003) Warehouse							
f GHz	SA reading (dBm)	Ant. Pol. (H/V)	Path Loss (dBm)	EIRP (dBm)	Limit (dBm)	Delta (dB)	Notes
1.851	-16.7	V	40.4	23.7	33.0	-9.3	
1.851	-26.8	H	39.7	12.9	33.0	-20.1	
1.880	-17.0	V	39.9	22.9	33.0	-10.1	
1.880	-28.3	H	40.1	11.8	33.0	-21.2	
1.909	-16.4	V	39.8	23.4	33.0	-9.6	
1.909	-28.2	H	40.2	11.9	33.0	-21.1	
Rev. 1.24.7							

7.2. FIELD STRENGTH OF SPURIOUS RADIATION

LIMIT

§22.917 (e) and §24.238 (a), RSS-132 § 4.5.1, & RSS-133 § 6.5.1 (a) (i) & (b): Out of band emissions. The power of any emission outside of the authorized operating frequency ranges must be attenuated below the transmitting power (P) by a factor of at least $43 + 10 \log (P)$ dB.

§27.53 (g) and RSS-139 § 6.5 For operations in the 1710–1755MHz and 2110–2155 MHz bands, the power of any emission outside a licensee's frequency block shall be attenuated below the transmitter power (P) by at least $43 + 10 \log_{10} (P)$ dB.

TEST PROCEDURE

ANSI / TIA / EIA 603 Clause 3.2.12 & FCC 22.917 (b) & FCC 24.238 (b), (g)(1)(2)(3), RSS-132 & RSS-133

RESULTS

1xRTT CDMA

CELL SPURIOUS & HARMONIC (ERP)

Compliance Certification Services
Above 1GHz High Frequency Substitution Measurement

Company: QUALCOMM
 Project #: 10U13553
 Date: 12/14/2010
 Test Engineer: MENGISTU MEKURIA
 Configuration: EUT WITH EXTERNAL ANTENNA
 Mode: TX, 1xRTT CELL BAND

Chamber

Pre-amplifier

Filter

Limit

5m Chamber A

T144 8449B

Filter 1

PART 22

f GHz	SA reading (dBm)	Ant. Pol. (H/V)	Distance (m)	Path Loss (dB)	Preamp (dB)	Filter (dB)	ERP (dBm)	Limit (dBm)	Delta (dB)	Notes
Low Channel (824.71 MHz)										
1.649	-49.5	H	3.0	36.6	38.2	1.0	-50.1	-13.0	-37.1	
3.299	-61.0	H	3.0	43.9	37.1	1.0	-53.3	-13.0	-40.3	
1.649	-42.3	V	3.0	36.8	38.2	1.0	-42.6	-13.0	-29.6	
2.474	-58.3	V	3.0	41.7	37.5	1.0	-53.0	-13.0	-40.0	
3.299	-60.8	V	3.0	44.0	37.1	1.0	-52.9	-13.0	-39.9	
Mid Channel (836.52 MHz)										
1.673	-53.4	H	3.0	36.8	38.1	1.0	-53.8	-13.0	-40.8	
3.346	-61.8	H	3.0	44.0	37.1	1.0	-53.9	-13.0	-40.9	
1.673	-51.8	V	3.0	37.1	38.1	1.0	-51.8	-13.0	-38.8	
2.510	-58.7	V	3.0	41.8	37.5	1.0	-53.3	-13.0	-40.3	
3.346	-58.6	V	3.0	44.1	37.1	1.0	-50.5	-13.0	-37.5	
Hi Channel (848.31 MHz)										
1.697	-53.4	H	3.0	37.0	38.1	1.0	-53.5	-13.0	-40.5	
3.393	-60.6	H	3.0	44.1	37.1	1.0	-52.5	-13.0	-39.5	
1.697	-53.3	V	3.0	37.4	38.1	1.0	-53.0	-13.0	-40.0	
2.545	-56.6	V	3.0	42.0	37.5	1.0	-51.1	-13.0	-38.1	
3.393	-60.8	V	3.0	44.2	37.1	1.0	-52.6	-13.0	-39.6	

Note: No other emissions were detected within 40dB limit to the noise floor
 Rev. 03.03.09

PCS Spurious & Harmonic (EIRP)

Compliance Certification Services
Above 1GHz High Frequency Substitution Measurement

Company: QUALCOMM
Project #: 10U13553
Date: 12/14/2010
Test Engineer: MENGISTU MEKURIA
Configuration: EUT WITH EXTERNAL ANTENNA
Mode: TX, 1xRTT PCS BAND

Chamber

Pre-amplifier

Filter

Limit

5m Chamber A

T144 8449B

Filter 1

PART 24

f GHz	SA reading (dBm)	Ant. Pol. (H/V)	Distance (m)	Path Loss (dB)	Preamp (dB)	Filter (dB)	EIRP (dBm)	Limit (dBm)	Delta (dB)	Notes
Low Channel (1851.25 MHz)										
3.703	-50.1	H	3.0	45.0	36.8	1.0	-40.9	-13.0	-27.9	
3.703	-49.8	V	3.0	44.9	36.8	1.0	-40.7	-13.0	-27.7	
		H								
Mid Channel (1880.00 MHz)										
3.760	-50.8	H	3.0	45.2	36.8	1.0	-41.4	-13.0	-28.4	
3.760	-47.2	V	3.0	45.1	36.8	1.0	-37.9	-13.0	-24.9	
		V								
Hi Channel (1908.75 MHz)										
3.818	-51.8	H	3.0	45.3	36.7	1.0	-42.2	-13.0	-29.2	
3.818	-49.3	V	3.0	45.2	36.7	1.0	-39.8	-13.0	-26.8	
		V								
		V								

Note: No other emissions were detected within 30dB limit to the noise floor
 Rev. 03.03.09

EVDO REV A CDMA

CELL SPURIOUS & HARMONIC (ERP)

Compliance Certification Services Above 1GHz High Frequency Substitution Measurement										
Company:		QUALCOMM								
Project #:		10U13553								
Date:		12/22/2010								
Test Engineer:		MENGISTU MEKURIA								
Configuration:		EUT WITH EXTERNAL ANTENNA								
Mode:		TX, EVDO REV. A CELL BAND								
Chamber		Pre-amplifier			Filter			Limit		
5m Chamber A		T144 8449B			Filter 1			PART 22		
f GHz	SA reading (dBm)	Ant. Pol. (H/V)	Distance (m)	Path Loss (dB)	Preamp (dB)	Filter (dB)	ERP (dBm)	Limit (dBm)	Delta (dB)	Notes
Low Channel (824.71 MHz)										
1.649	-44.5	H	3.0	36.6	38.2	1.0	-45.1	-13.0	-32.1	
3.299	-61.1	H	3.0	43.9	37.1	1.0	-53.4	-13.0	-40.4	
1.649	-37.2	V	3.0	36.8	38.2	1.0	-37.5	-13.0	-24.5	
2.474	-57.4	V	3.0	41.7	37.5	1.0	-52.2	-13.0	-39.2	
3.299	-57.9	V	3.0	44.0	37.1	1.0	-50.1	-13.0	-37.1	
Mid Channel (836.52 MHz)										
1.673	-52.3	H	3.0	36.8	38.1	1.0	-52.6	-13.0	-39.6	
3.346	-61.7	H	3.0	44.0	37.1	1.0	-53.8	-13.0	-40.8	
1.673	-50.2	V	3.0	37.1	38.1	1.0	-50.2	-13.0	-37.2	
2.510	-58.8	V	3.0	41.8	37.5	1.0	-53.4	-13.0	-40.4	
3.346	-59.4	V	3.0	44.1	37.1	1.0	-51.4	-13.0	-38.4	
Hi Channel (848.31 MHz)										
1.697	-55.4	H	3.0	37.0	38.1	1.0	-55.5	-13.0	-42.5	
3.393	-61.8	H	3.0	44.1	37.1	1.0	-53.7	-13.0	-40.7	
1.697	-53.2	V	3.0	37.4	38.1	1.0	-52.9	-13.0	-39.9	
2.545	-57.4	V	3.0	42.0	37.5	1.0	-51.9	-13.0	-38.9	
3.393	-58.3	V	3.0	44.2	37.1	1.0	-50.1	-13.0	-37.1	
<p>Note: No other emissions were detected within 40dB limit to the noise floor</p> <p>Rev. 03.03.09</p>										

PCS Spurious & Harmonic (EIRP)

Compliance Certification Services
Above 1GHz High Frequency Substitution Measurement

Company: QUALCOMM
Project #: 10U13553
Date: 12/22/2010
Test Engineer: MENGISTU MEKURIA
Configuration: EUT WITH EXTERNAL ANTENNA
Mode: TX, EVDO REV. A PCS BAND

Chamber

5m Chamber A

Pre-amplifier

T144 8449B

Filter

Filter 1

Limit

PART 24

f GHz	SA reading (dBm)	Ant. Pol. (H/V)	Distance (m)	Path Loss (dB)	Preamp (dB)	Filter (dB)	EIRP (dBm)	Limit (dBm)	Delta (dB)	Notes
Low Channel (1851.25 MHz)										
3.703	-48.6	H	3.0	45.0	36.8	1.0	-39.4	-13.0	-26.4	
3.703	-45.6	V	3.0	44.9	36.8	1.0	-36.5	-13.0	-23.5	
9.256	-61.0	V	3.0	54.2	37.0	1.0	-42.7	-13.0	-29.7	
Mid Channel (1880.00 MHz)										
3.760	-46.8	H	3.0	45.2	36.8	1.0	-37.4	-13.0	-24.4	
3.760	-43.8	V	3.0	45.1	36.8	1.0	-34.5	-13.0	-21.5	
9.400	-60.3	V	3.0	54.4	37.0	1.0	-42.0	-13.0	-29.0	
Hi Channel (1908.75 MHz)										
3.818	-45.6	H	3.0	45.3	36.7	1.0	-35.9	-13.0	-22.9	
3.818	-45.5	V	3.0	45.2	36.7	1.0	-36.1	-13.0	-23.1	
9.544	-59.4	V	3.0	54.6	37.1	1.0	-40.9	-13.0	-27.9	
		V								
		V								

Note: No other emissions were detected within 30dB limit to the noise floor
 Rev. 03.03.09

7.3. RECEIVER SPURIOUS EMISSIONS

LIMIT

RSS-Gen 7.2.2

Spurious Emission Limits for Receivers:

Spurious Frequency (MHz)	Field Strength (microvolts/m at 3 metres)
30-88	100
88-216	150
216-960	200
Above 960	500

TEST PROCEDURE

The search for spurious emissions shall be from the lowest frequency internally generated or used in the receiver (local oscillator frequency, intermediate frequency or carrier frequency), or 30 MHz, whichever is the higher, to at least 3 times the highest tunable and local oscillator frequencies.

RESULTS

SPURIOUS EMISSIONS 30 TO 1000 MHz (WORST-CASE CONFIGURATION)

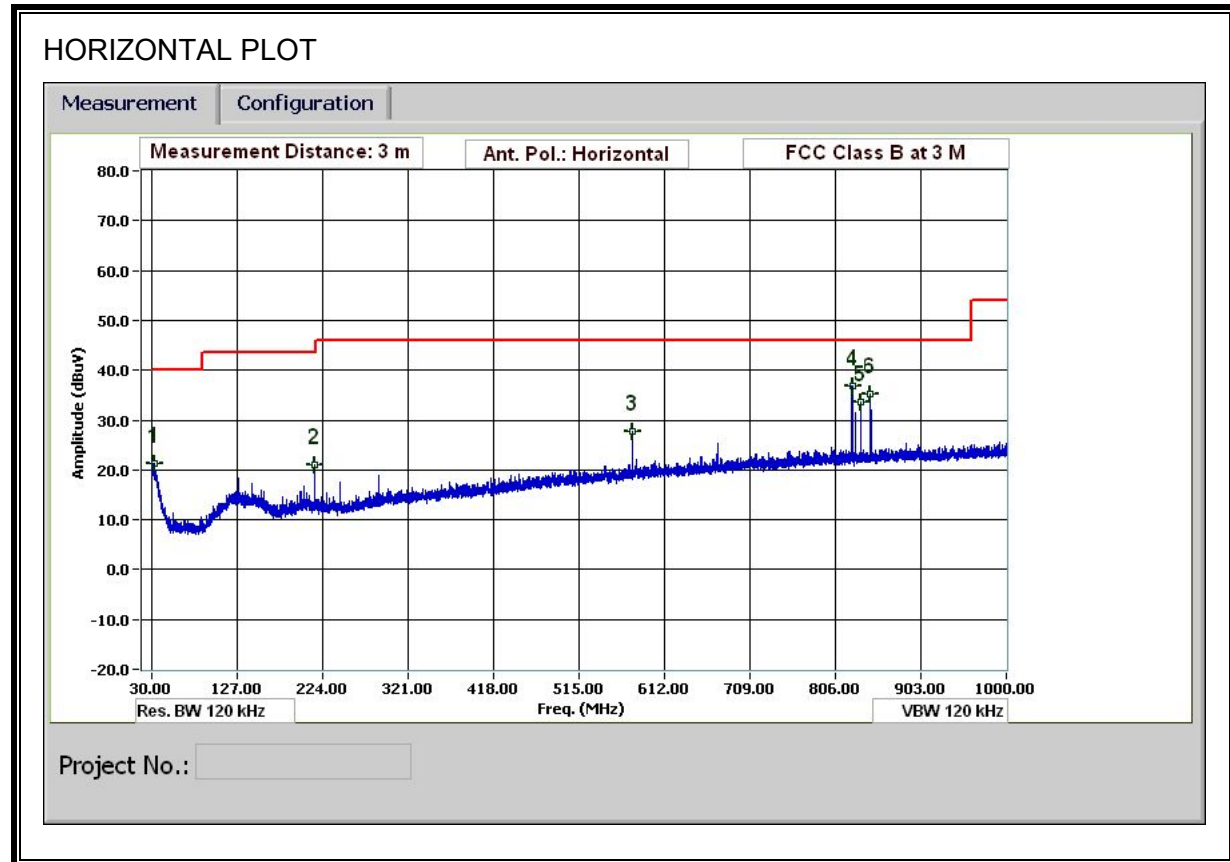

VERTICAL PLOT

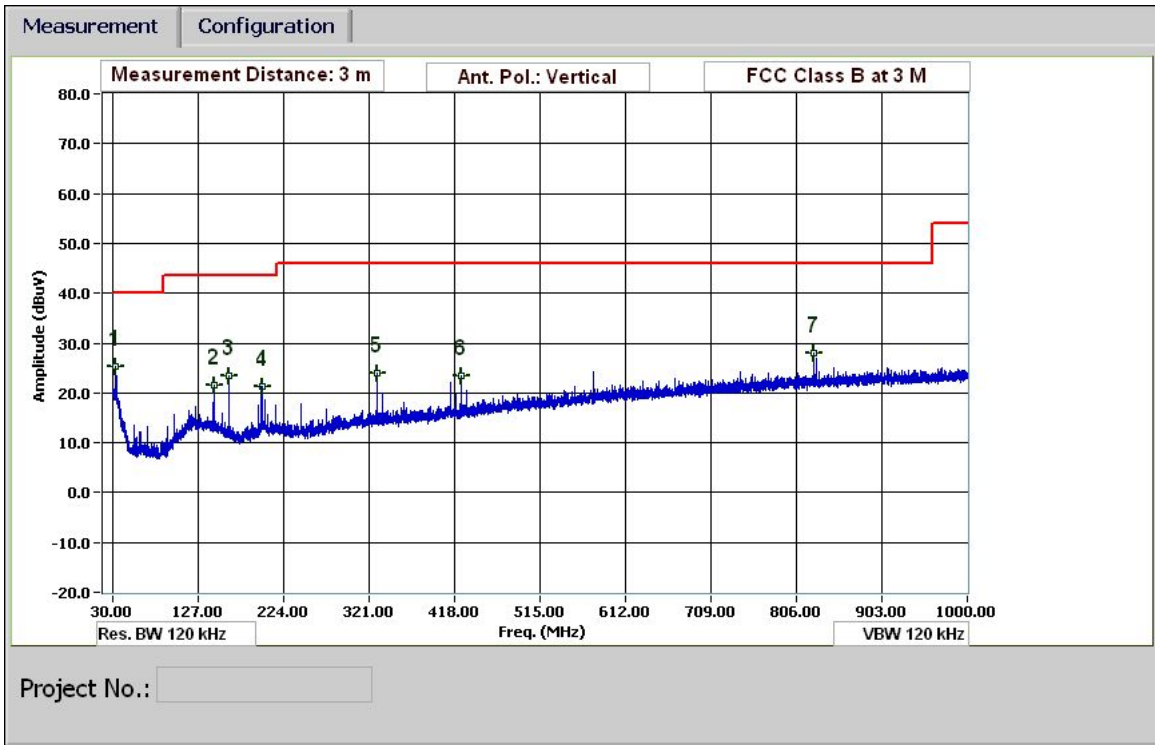

HORIZONTAL AND VERTICAL DATA

30-1000MHz Frequency Measurement
Compliance Certification Services, Fremont 5m Chamber

Test Engr: MENGISTU MEKURIA
Date: 10/14/10
Project #: 10U13553
Company: QUALQUAM
Test Target: FCC Class B
Mode Oper: Tx Mode

f Measurement Frequency Amp Preamp Gain Margin Margin vs. Limit
 Dist Distance to Antenna D Corr Distance Correct to 3 meters
 Read Analyzer Reading Filter Filter Insert Loss
 AF Antenna Factor Corr. Calculated Field Strength
 CL Cable Loss Limit Field Strength Limit

f MHz	Dist (m)	Read dBuV	AF dB/m	CL dB	Amp dB	D Corr dB	Pad dB	Corr. dBuV/m	Limit dBuV/m	Margin dB	Ant. Pol V/H	Det. P/A/QP	Notes
Data													
33.48	3.0	34.7	18.6	0.5	28.4	0.0	0.0	25.4	40.0	-14.6	V	P	
145.445	3.0	35.9	12.9	1.1	28.3	0.0	0.0	21.6	43.5	-21.9	V	P	
162.005	3.0	39.0	11.5	1.1	28.2	0.0	0.0	23.4	43.5	-20.1	V	P	
199.087	3.0	36.3	11.9	1.2	28.2	0.0	0.0	21.2	43.5	-22.3	V	P	
330.012	3.0	36.6	13.9	1.6	28.1	0.0	0.0	23.9	46.0	-22.1	V	P	
426.016	3.0	34.2	15.4	1.9	28.0	0.0	0.0	23.4	46.0	-22.6	V	P	
825.633	3.0	31.8	21.2	2.7	27.5	0.0	0.0	28.1	46.0	-17.9	V	P	
32.28	3.0	30.1	19.1	0.5	28.4	0.0	0.0	21.4	40.0	-18.6	H	P	
214.808	3.0	36.0	11.9	1.3	28.2	0.0	0.0	21.0	43.5	-22.5	H	P	
576.023	3.0	35.2	18.0	2.2	27.6	0.0	0.0	27.8	46.0	-18.2	H	P	
825.033	3.0	40.4	21.2	2.7	27.5	0.0	0.0	36.7	46.0	-9.3	H	P	
834.873	3.0	37.1	21.3	2.7	27.6	0.0	0.0	33.5	46.0	-12.5	H	P	
845.674	3.0	38.8	21.4	2.7	27.6	0.0	0.0	35.3	46.0	-10.7	H	P	

Rev. 1.27.09

Note: No other emissions were detected above the system noise floor.

SPURIOUS EMISSIONS ABOVE 1000 MHz (WORST-CASE CONFIGURATION)

Note: No emissions were detected above the system noise floor.