

Globalstar User Terminal Transmitter Antenna Port Conducted Narrowband Out-of-Band Emissions (OOBE) Test Plan

1.0 Introduction

This test plan describes the planned narrowband unwanted out-of-band emissions testing of the Globalstar user terminal (UT) transmitter antenna ports. This testing will support verification that the UT meets the FCC emissions limitation requirements specified in 47 CFR Ch. 1 (10-1-99 Edition), Part 25, Section 25.216 (a) (3), and Section 25.200 (c), and to provide data required for the UT Certification Reports as specified in Sections 2.983 and 2.991

(The new Section 25.216 emission limits, defined in the FCC Notice of Proposed Rule Making (NPRM) 99-37, adopted Feb. 25, 1999, are intended to implement the Global Mobile Personal Communications by Satellite (GMPCS) Memorandum of Understanding (MOU), providing protection for radionavigation services operating in the 1559-1605 MHz frequency band. The narrowband limit in the new proposed Section 25.216 is more stringent than and is expected to supercede the older emission limit in Section 25.213 (b) It is essentially the same as the limit defined in Section 25.200 (c) by Report & Order FCC 98-338, adopted Dec. 17, 1998.)

The OOBE testing described herein consists of manual narrowband high-frequency conducted antenna port OOBE testing in the 1559 to 1610 MHz frequency band to show compliance with the Part 25 Section 25.200 (c) and Section 25.216 (a) (3) narrowband (700 Hz bandwidth) emission limit, for an SMP UT with an out-of-band antenna gain equal to the worst case (+3 sigma) measured out-of-band antenna gain values (3.5 dB).

2.0 Test Configuration, Test Point , and Mode of Operation

The emissions shall be measured at the transmit coaxial antenna port connector inside the UT, using a UT with a special OOBE test antenna which provides external coaxial cable connector interfaces for the internal UT transmit and receive antenna ports, and providing a DC block for the latter to protect the Anritsu receiver from the DC bias voltage on the receive antenna low noise amplifier (LNA). The output signal shall be a real, full-power, full duty-cycle CDMA signal, transmitted by the UT; maintaining an RF link to an Anritsu tester while making the required OOBE measurements by means of coaxial cables, an RF power splitter, fixed-frequency bandstop filter, and a spectrum analyzer, as shown schematically in Figure 1.

Tests shall be performed at full rated output power: 3 dBW output power (P_t) equivalent to a maximum rated effective isotropic radiated power (EIRP) of 7 dBW for the fixed and mobile UT's, and -4 dBW output power equivalent to 0 dBW EIRP for portable UT's, with a maximum rated UT antenna gain of 4 dB. Tests shall be

performed for the lowest UT channel, Channel 1 (center frequency 1610.730 MHz), that being the worst case for emissions into the radionavigation band.

A Channel 1 notch filter is employed because the spectrum analyzer does not have a preselector filter and hence lacks sufficient frequency discrimination to measure signals more than 80 dB down in the presence of the transmitter carrier a few MHz above the stop frequency.

3.0 Emissions Test Limits

Table 1 identifies the FCC Part 25 narrowband conducted and radiated OOBE limits applicable to the Globalstar UT's in the 1559-1605 MHz band, measurement bandwidths, and bandwidth correction factors.

Table 1. Globalstar UT FCC Narrowband Out-of-Band Emissions Limits

Frequency Range (MHz)	FCC Pt. 25 Limits (dBW)	Narrowband Limit Bandwidth	Spectrum Analyzer Meas.BW (Hz)	Bandwidth Correction Factor (dB)	BW-Corrected FCC Pt. 25 Limits (dBW)
Radiated					
1559-1605	-80.0	700.0	1000.0	1.5	-78.5
			300.0	-3.7	-83.7
Conducted (1)					
1559-1605	-83.5	700.0	1000.0	1.5	-82.0
			300.0	-3.7	-87.2

(1) Equivalent Conducted Limit for 3.5 dB Out-of-Band Antenna Gain

4.0 Emissions Measurements

Tests shall be performed in 4 parts. First the aggregate losses of the coaxial cables, splitter, Channel 1 notch filter, and 6 dB attenuator pads shall be measured from 1559 to 1605 MHz using a network analyzer, as shown in Figure 2, and the loss-corrected emissions limits determined. Then the cable and splitter losses at 1610.73 MHz, without the filter and attenuator pads, shall be measured. Then connecting the spectrum analyzer directly with the notch/bandstop filter and 6 dB attenuator removed (refer to Figure 1), the transmitter antenna port conducted in-band emissions shall be measured at 1610.73 MHz using a 1 MHz bandwidth, to verify that the UT is transmitting at its full rated power. Finally out-of-band emissions shall be measured with the spectrum analyzer using 1 kHz and then 300 Hz resolution bandwidths and those measurements shall be compared to the corrected emissions limits.

Owing to spectrum analyzer limitations, direct measurements with a 700 Hz bandwidth are not possible; these resolution bandwidth values bracket the desired responses and have the smallest bandwidth correction values available for such narrowband measurements.

For the conducted OOB E measurements the spectrum analyzer should be set such that the nominal conducted limit (-83.5 dBW) is not more than 20dB above, just at, or below the spectrum analyzer reference level. That coupled with the aggregate cable, splitter, and filter losses will prevent potential spatter and other test artifacts due to overdriving the front end of the spectrum analyzer. The spectrum analyzer start and stop frequencies and bandwidths to be employed are shown in Table 2, following.

Table 2. Narrowband OOB E Test Frequency Bands

1 kHz Res. Bandwidth Measurements

Start Frequency (MHz)	Stop Frequency (MHz)
1559	1590
1590	1605

300 Hz Res. Bandwidth Measurements

Start Frequency (MHz)	Stop Frequency (MHz)
1559	1562
1562	1565
1565	1568
1568	1571
1571	1574
1574	1577
1577	1580
1580	1583
1583	1586
1586	1589
1589	1592
1592	1595
1595	1598
1598	1601
1601	1604
1604	1605

The UT shall be set to transmit at the maximum rated power. Using the Anritsu front panel, and the User Terminal diagnostic Monitor (UTDM) Software loaded in the ancillary PC connected to the UT data port, this test mode is established in the following manner:

Connect UT to PC serial data port using provided UT/RS-232 Adaptor cable. Boot up the Anritsu and the UTDM software in the PC. In UTDM open the Call Proc and Finger windows. Press the Anritsu CALL PROC soft key (on the bottom row of the front panel). Using the cursor keypad select service option SO2001, with all 0's 9600 bps (should be default), for maximum power and duty cycle EUT transmission, or service option SO1 with all 0's 9600 bps and 50 frames delay, for 1-second delay loopback mode. Select the appropriate transmit channel (1, 6, or 9) and receive channel 7 (usual default). Input beam reference level should be set to 20 dBm and Primary Beam should initially be set to about -70 dBm.

Press the menu cursor (left arrow) key at the bottom right of the screen, to select Menu #2, then press the revealed Start softkey. The Call Proc status display in the upper right corner of the screen will cycle through idle, regist., and idle reg. When idle reg. Call Proc is displayed, press the NW Orig softkey (at the bottom of the screen). When the call is picked up the Call Proc status display will show Termination, then flash TC INIT, followed by Conversation when the link has been established between the Anritsu Tester and the EUT. Primary Beam level is adjusted until Ec/Io shown in UTDM Finger window reaches -17.4 dB (typically the primary beam level is between -60 to -75 dBm to achieve the appropriate Ec/Io with a direct connection to the Anritsu). Disconnect UT from PC during OOB E test.

Emissions shall be measured in swept-frequency mode across the frequency spans defined in Table 2, which have been selected to provide sufficient emissions characterization data within a reasonable test time frame, as determined by the combined sweep time, frequency span, and resolution bandwidth characteristics of the spectrum analyzer. The inband power level shall be recorded and plots shall be made of each swept frequency span.

5.0. Narrowband Conducted Antenna Port OOB E Test Equipment

The following test equipment shall be employed in performing this test:

- 1) Spectrum Analyzer – HP 8595E
- 2) Network Analyzer – HP 8753D
- 3) Cable #1 with SMA / OSX Adaptor
- 4) Cable #2, 0.5 m
- 5) Cable #3 with SMA/Type N Adaptor, 1 m
- 6) Cable #4 with SMA/Type N Adaptor , 1 m
- 7) Cable #5 with SMA/Type TNC Adaptor , 1 m
- 8) Cable #6 with Male and Female OSX Connector/Adaptors
- 9) Channel 1 Bandstop Filter, Lorch Microwave
- 10) 6 dB attenuator pads, Type SMA, 2 each to terminate/match filter ports
- 11) RF Power Splitter – Narda 4426-2 (10 W, 0.5-18 GHz)
- 12) Anritsu MT 8803G Globalstar UT Tester
- 13) 50 ohm Terminator, Type SMA

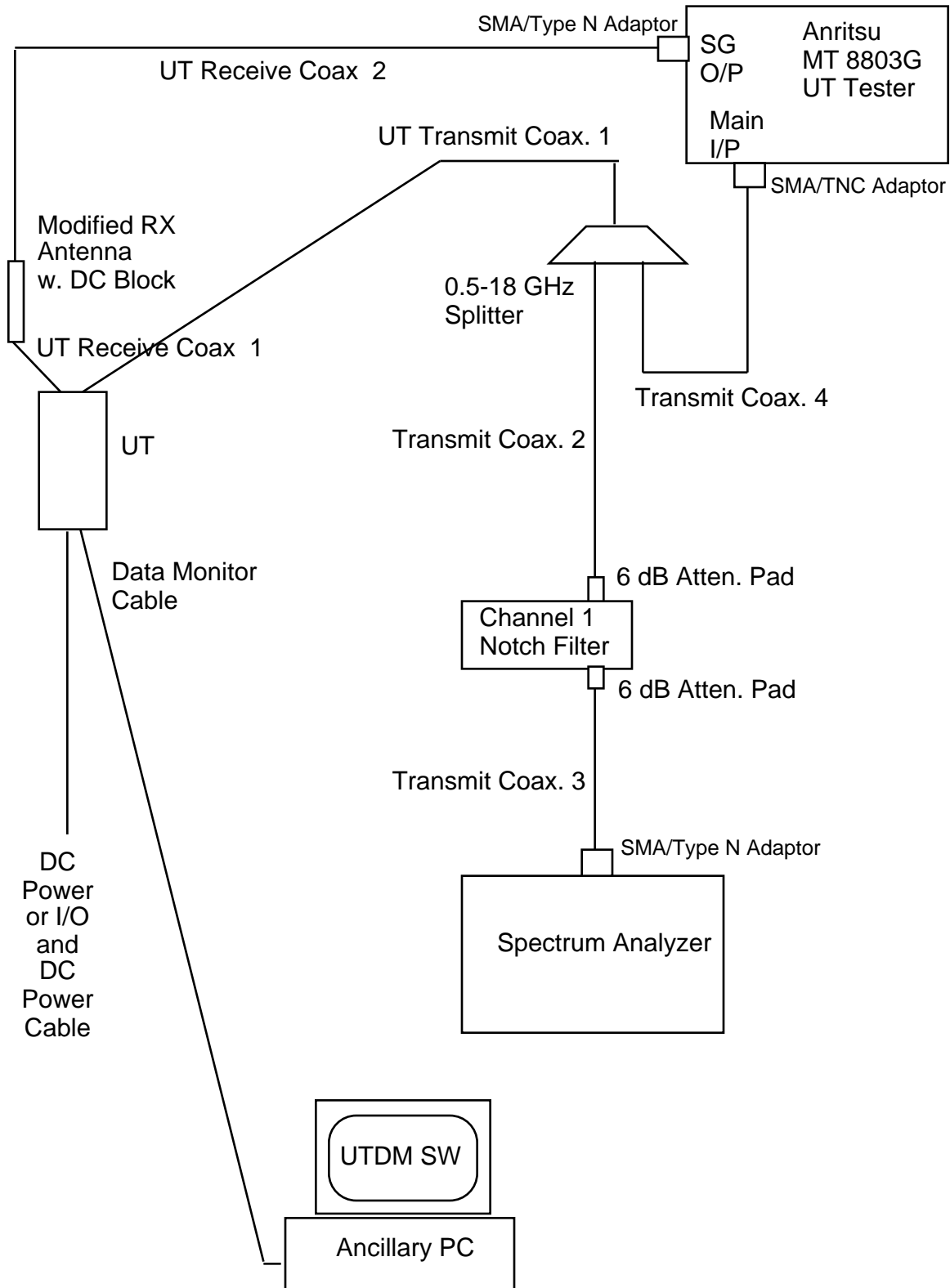

Figure 1. UT FCC Part 25 NB OOBE Test Setup

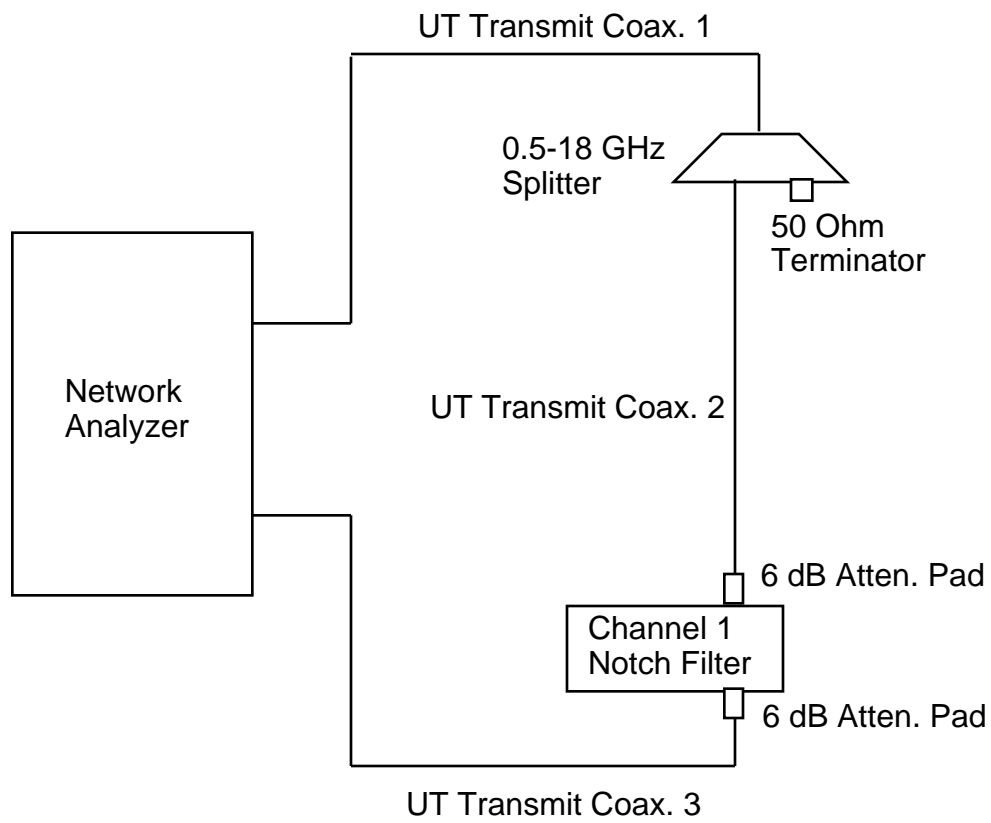

Figure 2. UT FCC Part 25 NB OOBE Calibration Setup

Table 3. Loss-Corrected FCC OOBE Emissions Limits

[Corrected Limit (dBm) = Norm. Limit (dBW + BW Corr. Factor (dB) + Combined Splitter, Filter, Attenuators and Cable Losses Corr. Factor (dB) + 30 dB]

Frequency Range (MHz)	FCC Pt. 25 Limits (dBW)	Spectrum Analyzer Meas. BW (Hz)	Bandwidth Correction Factor (dB)	Filter + Splitter+ Atten + Cable Loss Corr. Factor (dB)	Corrected FCC Pt. 25 OOBE Meas. Limits (dBm)
Radiated	dBW/700 Hz				
1559 - 1605	-80	1000	1.5		
1559 - 1605	-80	300	-3.7		
Conducted (1)	dBW/700 Hz				
1559-1590	-83.5	1000	1.5		
1590-1605	-83.5	1000	1.5		
1559 - 1562	-83.5	300	-3.7		
1562 - 1565	-83.5	300	-3.7		
1565 - 1568	-83.5	300	-3.7		
1598 - 1571	-83.5	300	-3.7		
1571 - 1574	-83.5	300	-3.7		
1574 - 1577	-83.5	300	-3.7		
1577 - 1580	-83.5	300	-3.7		
1580 - 1583	-83.5	300	-3.7		
1583 - 1586	-83.5	300	-3.7		
1586 - 1589	-83.5	300	-3.7		
1589 - 1592	-83.5	300	-3.7		
1592 - 1595	-83.5	300	-3.7		
1595 - 1598	-83.5	300	-3.7		
1598 - 1601	-83.5	300	-3.7		
1601 - 1604	-83.5	300	-3.7		
1604 - 1605	-83.5	300	-3.7		

(1) Equivalent Conducted Limit for 3.5 dB Out-of-Band Antenna Gain

OOBE Test Instrumentation Calibration Data Record

Test Instrument	Manuf. Model No.	Serial No.	Last Cal	Cal Due
Spectrum Analyzer (9 kHz – 6.5 GHz)	HP 8595 E			
Network Analyzer (30 kHz – 6 GHz)	HP 8753 D			
RF Power Splitter (0.5 – 18 GHz)	Narda Model 4426-2			
Channel 1 Notch Filter	Lorch Microwave 6CN-1610.73/X2-SM/SM	1221-17131-1610 29971 S/N Y2	N/A	N/A
Globalstar UT Tester	Anritsu MT 8803G			