

Supplemental “Transmit Simultaneously” Test Report

Report No.: RFBWIN-WTW-P22110682-6

FCC ID: J9C-QCNCM865

Test Model: QCNCM865

Received Date: 2022/11/24

Test Date: 2023/2/20 ~ 2023/2/23

Issued Date: 2023/3/21

Applicant: Qualcomm Technologies, Inc.

Address: 5775 Morehouse Drive, San Diego, CA 92121-1714

Issued By: Bureau Veritas Consumer Products Services (H.K.) Ltd., Taoyuan Branch
Hsin Chu Laboratory

Lab Address: E-2, No.1, Li Hsin 1st Road, Hsinchu Science Park, Hsinchu City 300,
Taiwa.

Test Location: E-2, No.1, Li Hsin 1st Road, Hsinchu Science Park, Hsinchu City 300,
Taiwan.

**FCC Registration /
Designation Number:** 723255 / TW2022



This report is governed by, and incorporates by reference, the Conditions of Testing as posted at the date of issuance of this report at <http://www.bureauveritas.com/home/about-us/our-business/cps/about-us/terms-conditions/> and is intended for your exclusive use. Any copying or replication of this report to or for any other person or entity, or use of our name or trademark, is permitted only with our prior written permission. This report sets forth our findings solely with respect to the test samples identified herein. The results set forth in this report are not indicative or representative of the quality or characteristics of the lot from which a test sample was taken or any similar or identical product unless specifically and expressly noted. Our report includes all of the tests requested by you and the results thereof based upon the information that you provided to us. Measurement uncertainty is only provided upon request for accredited tests. Statements of conformity are based on simple acceptance criteria without taking measurement uncertainty into account, unless otherwise requested in writing. You have 60 days from date of issuance of this report to notify us of any material error or omission caused by our negligence or if you require measurement uncertainty; provided, however, that such notice shall be in writing and shall specifically address the issue you wish to raise. A failure to raise such issue within the prescribed time shall constitute your unqualified acceptance of the completeness of this report, the tests conducted and the correctness of the report contents.

Table of Contents

Release Control Record	3
1 Certificate of Conformity	4
2 Summary of Test Results	5
2.1 Measurement Uncertainty.....	5
2.2 Modification Record.....	5
3 General Information	6
3.1 General Description of EUT.....	6
3.2 Description of Antenna.....	9
3.2.1 Test Mode Applicability and Tested Channel Detail.....	10
3.3 Description of Support Units.....	14
3.3.1 Configuration of System under Test.....	15
4 Test Types and Results	16
4.1 Radiated Emission and Bandedge Measurement.....	16
4.1.1 Limits of Radiated Emission and Bandedge Measurement.....	16
4.1.2 Test Instruments.....	17
4.1.3 Test Procedures.....	19
4.1.4 Deviation from Test Standard.....	20
4.1.5 Test Setup.....	21
4.1.6 EUT Operating Conditions.....	22
4.1.7 Test Results (Conducted Measurement).....	23
4.1.8 Test Results (Radiated Measurement).....	48
4.2 Conducted Emission Measurement.....	67
4.2.1 Limits of Conducted Emission Measurement.....	67
4.2.2 Test Instruments.....	67
4.2.3 Test Procedures.....	68
4.2.4 Deviation from Test Standard.....	68
4.2.5 Test Setup.....	68
4.2.6 EUT Operating Conditions.....	68
4.2.7 Test Results (Mode 1).....	69
4.2.8 Test Results (Mode 2).....	71
4.2.9 Test Results (Mode 3).....	73
4.2.10 Test Results (Mode 4).....	75
4.2.11 Test Results (Mode 5).....	77
4.2.12 Test Results (Mode 6).....	79
4.3 Conducted Out of Band Emission Measurement.....	81
4.3.1 Limits of Conducted Out of Band Emission Measurement.....	81
4.3.2 Test Setup.....	81
4.3.3 Test Instruments.....	81
4.3.4 Test Procedures.....	81
4.3.5 Deviation from Test Standard.....	81
4.3.6 EUT Operating Conditions.....	81
4.3.7 Test Results (Mode 1).....	82
4.3.8 Test Results (Mode 2).....	82
4.3.9 Test Results (Mode 3).....	83
4.3.10 Test Results (Mode 4).....	83
4.3.11 Test Results (Mode 5).....	84
4.3.12 Test Results (Mode 6).....	84
5 Pictures of Test Arrangements	85
Appendix – Information of the Testing Laboratories	86

Release Control Record

Issue No.	Description	Date Issued
RFBWIN-WTW-P22110682-6	Original release.	2023/3/21

1 Certificate of Conformity

Product: Qualcomm WiFi 7/BT Combo module

Brand: Qualcomm

Test Model: QCNCM865

Sample Status: Engineering sample

Applicant: Qualcomm Technologies, Inc.

Test Date: 2023/2/20 ~ 2023/2/23

Standards: 47 CFR FCC Part 15, Subpart C (Section 15.247)
47 CFR FCC Part 15, Subpart E (Section 15.407)
ANSI C63.10: 2013

The above equipment has been tested by **Bureau Veritas Consumer Products Services (H.K.) Ltd., Taoyuan Branch**, and found compliance with the requirement of the above standards. The test record, data evaluation & Equipment Under Test (EUT) configurations represented herein are true and accurate accounts of the measurements of the sample's EMC characteristics under the conditions specified in this report.

Prepared by : Vivian Huang , **Date:** 2023/3/21
Vivian Huang / Specialist

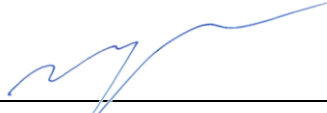
Approved by :  , **Date:** 2023/3/21
May Chen / Manager

2 Summary of Test Results

FCC Part 15, Subpart C, E (SECTION 15.247, 15.407)			
FCC Clause	Test Item	Result	Remarks
15.207 15.407(b)(6)	AC Power Conducted Emission	Pass	Meet the requirement of limit. Minimum passing margin is -9.36 dB at 0.56790 MHz.
15.205 / 15.209 / 15.247(d) 15.407(b) (1/2/3/4(i/ii)/6)	Radiated Emissions and Band Edge Measurement	Pass	Meet the requirement of limit. Minimum passing margin is -3.8 dB at 297.02 MHz.

Note:

Determining compliance based on the results of the compliance measurement, not taking into account measurement instrumentation uncertainty.

2.1 Measurement Uncertainty

Where relevant, the following measurement uncertainty levels have been estimated for tests performed on the EUT as specified in CISPR 16-4-2:

Measurement	Frequency	Expanded Uncertainty (k=2) (\pm)
Conducted Emissions at mains ports	150kHz ~ 30MHz	1.9 dB
Conducted Emissions	-	2.5 dB
Radiated Emissions up to 1 GHz	9kHz ~ 30MHz	3.1 dB
	30MHz ~ 1GHz	5.1 dB
Radiated Emissions above 1 GHz	1GHz ~ 18GHz	5.1 dB
	18GHz ~ 40GHz	5.3 dB

2.2 Modification Record

There were no modifications required for compliance.

3 General Information

3.1 General Description of EUT

Product	Qualcomm WiFi 7/BT Combo module
Brand	Qualcomm
Test Model	QCNCM865
Status of EUT	Engineering sample
Power Supply Rating	3.3Vdc from host equipment
Modulation Type	WLAN: CCK, DQPSK, DBPSK for DSSS 64QAM, 16QAM, QPSK, BPSK for OFDM 1024QAM for OFDM in 11ac mode and VHT in 2.4GHz mode 4096QAM for OFDMA in 11ax mode 4096QAM for OFDMA in 11be mode BT-EDR: GFSK, $\pi/4$ -DQPSK, 8DPSK BT-LE: GFSK
Modulation Technology	WLAN: DSSS, OFDM, OFDMA BT-EDR: FHSS BT-LE: DTS
Transfer Rate	802.11a: up to 54 Mbps 802.11n: up to 300 Mbps 802.11ac: up to 1733.3 Mbps 802.11ax: up to 2401.9 Mbps 802.11be: up to 5764.8 Mbps
Operating Frequency	WLAN: 2.4GHz: 2.412 ~ 2.472 GHz 5GHz: 5.18 GHz ~ 5.25 GHz, 5.25 GHz ~ 5.32 GHz, 5.5 GHz ~ 5.72 GHz, 5.745 GHz ~ 5.825 GHz 5.9GHz: 5.835 GHz ~ 5.885 GHz 6GHz: Under control by Standard Power AP: 5.935 GHz ~ 6.415 GHz 6.535 GHz ~ 6.865 GHz Under control by Low-power Indoor AP: 5.935 GHz ~ 6.415 GHz 6.425 GHz ~ 6.525 GHz 6.535 GHz ~ 6.865 GHz 6.875 GHz ~ 7.115 GHz BT-EDR: 2.402 ~ 2.480GHz BT-LE: 2.402 ~ 2.480GHz
Antenna Type	Refer to section 3.2
Antenna Connector	Refer to section 3.2
Accessory Device	NA
Data Cable Supplied	NA

Note:

1. There are Bluetooth and WLAN (2.4 GHz & 5 GHz & 5.9 GHz & 6 GHz) technology used for the EUT.
2. Simultaneously transmission condition.

DBS		
Condition	Technology	
1	WLAN(2.4GHz)_Ant 0+1	WLAN(5GHz) _Ant 0+1
2	WLAN(2.4GHz) _Ant 0+1	WLAN(6GHz) _Ant 0+1

HBS+BT			
Condition	Technology		
3	Bluetooth_Ant 0+1	WLAN(5GHz) _Ant 0+1	
4	Bluetooth_Ant 0+1	WLAN(6GHz) _Ant 0+1	
5	WLAN(5GHz_U-NII-1, U-NII-2A) _Ant 0+1	WLAN(5GHz_U-NII-2C, U-NII-3, U-NII-4) _Ant 0+1	Bluetooth
6	WLAN(5GHz_U-NII-1, U-NII-2A) _Ant 0+1	WLAN(6GHz) _Ant 0+1	Bluetooth

Note: The emission of the simultaneous operation has been evaluated and no non-compliance was found.

3. QCNCM865 has HW variant SKUs below to support different Microsoft Windows platform system and feature:

SKU	Support platform system and feature
NCM865	X86 platform, support DBS and HBS
NCM865A	Qualcomm platform, support DBS and HBS
NCM835	X86 platform, support DBS
NCM835A	Qualcomm platform, support DBS

Note: From the above SKUs, the worst was found in **SKU (NCM865)**. Therefore only the test data of the modes were recorded in this report.

4. The EUT support OFDMA and Partial RU mode, therefore partial RU combination were investigated and the worst case scenario was identified.

5. The EUT incorporates a MIMO function:

2.4 GHz Band		
Modulation Mode	TX & RX Configuration	
802.11b	2TX	2RX
802.11g	2TX	2RX
802.11n (HT20)	2TX	2RX
802.11n (HT40)	2TX	2RX
VHT20	2TX	2RX
VHT40	2TX	2RX
802.11ax (HE20)	2TX	2RX
802.11ax (HE40)	2TX	2RX
802.11be (EHT20)	2TX	2RX
802.11be (EHT40)	2TX	2RX
802.11ax (RU26/52/106/242/484/52+26/106+26)	2TX	2RX

5 GHz Band		
Modulation Mode	TX & RX Configuration	
802.11a	2TX	2RX
802.11n (HT20)	2TX	2RX
802.11n (HT40)	2TX	2RX
802.11ac (VHT20)	2TX	2RX
802.11ac (VHT40)	2TX	2RX
802.11ac (VHT80)	2TX	2RX
802.11ac (VHT160)	2TX	2RX
802.11ax (HE20)	2TX	2RX
802.11ax (HE40)	2TX	2RX
802.11ax (HE80)	2TX	2RX
802.11ax (HE160)	2TX	2RX
802.11be (EHT20)	2TX	2RX
802.11be (EHT40)	2TX	2RX
802.11be (EHT80)	2TX	2RX
802.11be (EHT160)	2TX	2RX
802.11ax (RU26/52/106/242/484/996/2x996/52 +26/106+26/ 484+242/996+484/996+484+242)	2TX	2RX
6GHz Band		
MODULATION MODE	TX & RX CONFIGURATION	
802.11a	2TX	2RX
802.11ax (HE20)	2TX	2RX
802.11ax (HE40)	2TX	2RX
802.11ax (HE80)	2TX	2RX
802.11ax (HE160)	2TX	2RX
802.11be (EHT20)	2TX	2RX
802.11be (EHT40)	2TX	2RX
802.11be (EHT80)	2TX	2RX
802.11be (EHT160)	2TX	2RX
802.11be (EHT320)	2TX	2RX
802.11ax/be (RU26/52/106/242/484/996/996x2/ 996x4)	2TX	2RX
802.11be (RU996x4/52+26/106+26/484+242/ 996+484+242/ 996x2+484/996x3/ 996x3+484)	2TX	2RX

6. The above EUT information is declared by manufacturer and for more detailed features description, please refers to the manufacturer's specifications or user's manual.

3.2 Description of Antenna

The antenna gain was declared by client; please refer to the following table:

Antenna Set	RF Chain No.	Brand	Model	Antenna Net Gain (dBi)	Frequency Range	Cable Loss (dB)	Antenna Type	Connector Type	Cable Length
1	Chain0/1	Hong-Bo	260-25094	3.53	2.4~2.4835GHz	0.74	PIFA	MHF 4L	300mm
				3.06	5.15~5.25GHz	1.16			
				3.07	5.25~5.35GHz	1.18			
				4.81	5.47~5.725GHz	1.26			
				4.2	5.725~5.850GHz	1.28			
2	Chain0/1	Hong-Bo	260-25083	5.09	5.850~5.895 GHz	1.29	PIFA	MHF 4L	300mm
				5.14	5.925~6.425 GHz	1.35			
				5.09	6.425~6.525 GHz	1.38			
				5.16	6.525~6.875 GHz	1.45			
				5.12	6.875~7.125 GHz	1.50			
3	Chain0/1	Hong-Bo	260-25084	3.22	2.4~2.4835 GHz	0.49	Monopole	MHF 4L	200mm
				3.35	5.150~5.250 GHz	0.76			
				3.42	5.250~5.350 GHz	0.77			
				4.77	5.470~5.725 GHz	0.80			
				4.72	5.725~5.850 GHz	0.84			
				4.71	5.850~5.895 GHz	0.84			
				4.75	5.925~6.425 GHz	0.86			
				4.29	6.425~6.525 GHz	0.91			
				4.81	6.525~6.875 GHz	0.96			
				4.74	6.875~7.125 GHz	0.98			

* Detail antenna specification please refer to antenna datasheet and/or antenna measurement report.

3.2.1 Test Mode Applicability and Tested Channel Detail

EUT Configure Mode	Applicable To				Description
	RE \geq 1G	RE $<$ 1G	PLC	OB	
-	√	√	√	√	-

Where **RE \geq 1G**: Radiated Emission above 1GHz

RE $<$ 1G: Radiated Emission below 1GHz

PLC: Power Line Conducted Emission

OB: Conducted Out-Band Emission Measurement

Radiated Emission Test (Above 1GHz): (Radiated with 50 ohm load)

The tested configurations represent the worst-case mode from all possible combinations by the maximum power.

Following channel(s) was (were) selected for the final test as listed below.

Configure Mode	MODE	AVAILABLE CHANNEL	TESTED CHANNEL	MODULATION TECHNOLOGY	MODULATION TYPE
1	2.4GHz: 802.11b	1 to 13	1	DSSS	DBPSK
	+ 5GHz: 802.11be (EHT20)	100 to 144	116	OFDMA	BPSK
2	2.4GHz: 802.11b	1 to 13	1	DSSS	DBPSK
	+ 6GHz: 802.11be (EHT20)	2 to 93	45	OFDMA	BPSK
3	BT-LE	0 to 39	19	DTS	GFSK
	+ 5GHz: 802.11be (EHT20)	100 to 144	116	OFDMA	BPSK
4	BT-LE	0 to 39	19	DTS	GFSK
	+ 6GHz: 802.11be (EHT20)	2 to 93	45	OFDMA	BPSK
5	5GHz: 802.11be (EHT20) (U-NII-1, U-NII-2A)	36 to 48	40	OFDMA	BPSK
	+ 5GHz: 802.11be (EHT20) (U-NII-2C, U-NII-3, U-NII-4)	100 to 144	116	OFDMA	BPSK
	+ BT-LE	0 to 39	19	DTS	GFSK
6	5GHz: 802.11be (EHT20) (U-NII-1, U-NII-2A)	36 to 48	40	OFDMA	BPSK
	+ 6GHz: 802.11be (EHT20)	2 to 93	45	OFDMA	BPSK
	+ BT-LE	0 to 39	19	DTS	GFSK

Radiated Emission Test (Below 1GHz): ([Radiated with 50 ohm load](#))

The tested configurations represent the worst-case mode from all possible combinations by the maximum power.

Following channel(s) was (were) selected for the final test as listed below.

Configure Mode	MODE	AVAILABLE CHANNEL	TESTED CHANNEL	MODULATION TECHNOLOGY	MODULATION TYPE
1	2.4GHz: 802.11b	1 to 13	1	DSSS	DBPSK
	+ 5GHz: 802.11be (EHT20)	100 to 144	116	OFDMA	BPSK
2	2.4GHz: 802.11b	1 to 13	1	DSSS	DBPSK
	+ 6GHz: 802.11be (EHT20)	2 to 93	45	OFDMA	BPSK
3	BT-LE	0 to 39	19	DTS	GFSK
	+ 5GHz: 802.11be (EHT20)	100 to 144	116	OFDMA	BPSK
4	BT-LE	0 to 39	19	DTS	GFSK
	+ 6GHz: 802.11be (EHT20)	2 to 93	45	OFDMA	BPSK
5	5GHz: 802.11be (EHT20) (U-NII-1, U-NII-2A)	36 to 48	40	OFDMA	BPSK
	+ 5GHz: 802.11be (EHT20) (U-NII-2C, U-NII-3, U-NII-4)	100 to 144	116	OFDMA	BPSK
	+ BT-LE	0 to 39	19	DTS	GFSK
6	5GHz: 802.11be (EHT20) (U-NII-1, U-NII-2A)	36 to 48	40	OFDMA	BPSK
	+ 6GHz: 802.11be (EHT20))	2 to 93	45	OFDMA	BPSK
	+ BT-LE	0 to 39	19	DTS	GFSK

Power Line Conducted Emission Test:

The tested configurations represent the worst-case mode from all possible combinations by the maximum power.

Following channel(s) was (were) selected for the final test as listed below.

Configure Mode	MODE	AVAILABLE CHANNEL	TESTED CHANNEL	MODULATION TECHNOLOGY	MODULATION TYPE
1	2.4GHz: 802.11b +	1 to 13	1	DSSS	DBPSK
	5GHz: 802.11be (EHT20)	100 to 144	116	OFDMA	BPSK
2	2.4GHz: 802.11b +	1 to 13	1	DSSS	DBPSK
	6GHz: 802.11be (EHT20)	2 to 93	45	OFDMA	BPSK
3	BT-LE +	0 to 39	19	DTS	GFSK
	5GHz: 802.11be (EHT20)	100 to 144	116	OFDMA	BPSK
4	BT-LE +	0 to 39	19	DTS	GFSK
	6GHz: 802.11be (EHT20)	2 to 93	45	OFDMA	BPSK
5	5GHz: 802.11be (EHT20) (U-NII-1, U-NII-2A) +	36 to 48	40	OFDMA	BPSK
	5GHz: 802.11be (EHT20) (U-NII-2C, U-NII-3, U-NII-4) +	100 to 144	116	OFDMA	BPSK
	BT-LE	0 to 39	19	DTS	GFSK
6	5GHz: 802.11be (EHT20) (U-NII-1, U-NII-2A) +	36 to 48	40	OFDMA	BPSK
	6GHz: 802.11be (EHT20)) +	2 to 93	45	OFDMA	BPSK
	BT-LE	0 to 39	19	DTS	GFSK

Conducted Out-Band Emission Measurement:

The tested configurations represent the worst-case mode from all possible combinations by the maximum power.

Following channel(s) was (were) selected for the final test as listed below.

Configure Mode	MODE	AVAILABLE CHANNEL	TESTED CHANNEL	MODULATION TECHNOLOGY	MODULATION TYPE
1	2.4GHz: 802.11b +	1 to 13	1	DSSS	DBPSK
	5GHz: 802.11be (EHT20)	100 to 144	116	OFDMA	BPSK
2	2.4GHz: 802.11b +	1 to 13	1	DSSS	DBPSK
	6GHz: 802.11be (EHT20)	2 to 93	45	OFDMA	BPSK
3	BT-LE +	0 to 39	19	DTS	GFSK
	5GHz: 802.11be (EHT20)	100 to 144	116	OFDMA	BPSK
4	BT-LE +	0 to 39	19	DTS	GFSK
	6GHz: 802.11be (EHT20)	2 to 93	45	OFDMA	BPSK
5	5GHz: 802.11be (EHT20) (U-NII-1, U-NII-2A) +	36 to 48	40	OFDMA	BPSK
	5GHz: 802.11be (EHT20) (U-NII-2C, U-NII-3, U-NII-4) +	100 to 144	116	OFDMA	BPSK
	BT-LE	0 to 39	19	DTS	GFSK
6	5GHz: 802.11be (EHT20) (U-NII-1, U-NII-2A) +	36 to 48	40	OFDMA	BPSK
	6GHz: 802.11be (EHT20)) +	2 to 93	45	OFDMA	BPSK
	BT-LE	0 to 39	19	DTS	GFSK

Test Condition:

Applicable To	Environmental Conditions	Input Power (System)	Tested By
RE \geq 1G	25deg. C, 75%RH	120Vac, 60Hz	Louis Yang
RE $<$ 1G	25deg. C, 68%RH	120Vac, 60Hz	Louis Yang
PLC	25deg. C, 75%RH	120Vac, 60Hz	Carter Lin
OB	24deg. C, 57%RH	120Vac, 60Hz	Eric Peng

3.3 Description of Support Units

The EUT has been tested as an independent unit together with other necessary accessories or support units. The following support units or accessories were used to form a representative test configuration during the tests.

ID	Product	Brand	Model No.	Serial No.	FCC ID	Remarks
A	Laptop	Dell	E5420	6FGHKV1	N/A	Provided by Lab
B	Test Tool	Qualcomm	N/A	N/A	N/A	Supplied by applicant
C	Adapter	PHIHONG	PSAA12A-120L6	N/A	N/A	Supplied by applicant
D	Adapter	Dell	LLA65NS2-01	N/A	N/A	Provided by Lab

ID	Cable Descriptions	Qty.	Length (m)	Shielding (Yes/No)	Cores (Qty.)	Remarks
1	DC Cable	1	1.2	NO	0	Supplied by applicant
2	USB Cable	1	0.6	Yes	0	Provided by Lab
3	DC Cable	1	1.8	NO	1	Provided by Lab
4	AC Cable	1	1.5	NO	0	Provided by Lab

3.3.1 Configuration of System under Test
For AC Power Conducted Emission test

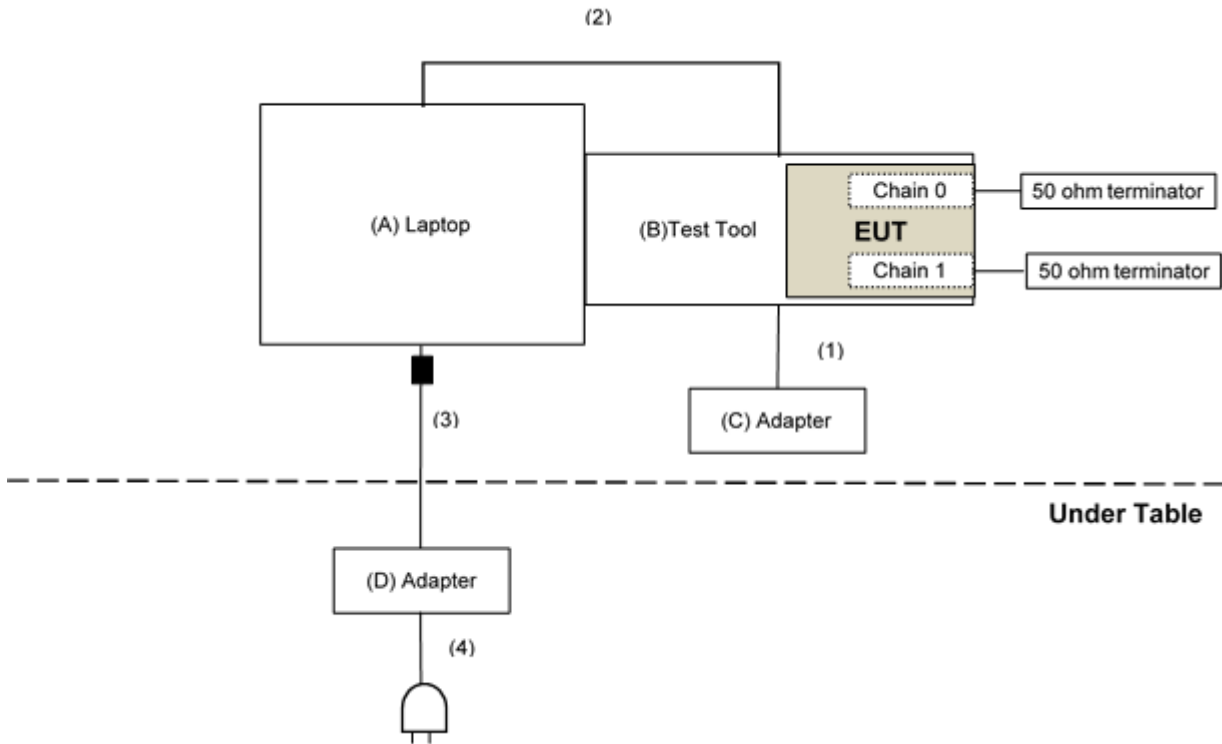

For Radiated Emission test

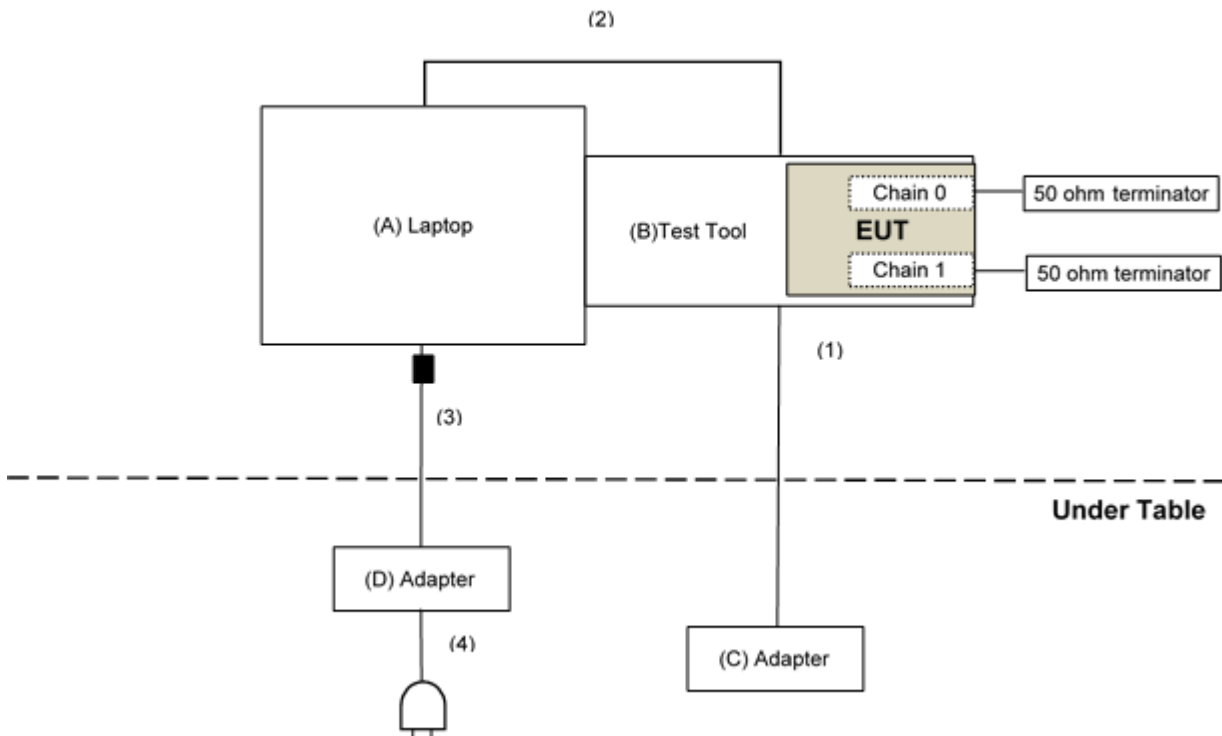

4 Test Types and Results

4.1 Radiated Emission and Bandedge Measurement

4.1.1 Limits of Radiated Emission and Bandedge Measurement

Radiated emissions which fall in the restricted bands must comply with the radiated emission limits specified as below table.

Frequencies (MHz)	Field Strength (microvolts/meter)	Measurement Distance (meters)
0.009 ~ 0.490	2400/F(kHz)	300
0.490 ~ 1.705	24000/F(kHz)	30
1.705 ~ 30.0	30	30
30 ~ 88	100	3
88 ~ 216	150	3
216 ~ 960	200	3
Above 960	500	3

Note:

1. The lower limit shall apply at the transition frequencies.
2. Emission level (dBuV/m) = 20 log Emission level (uV/m).
3. For frequencies above 1000MHz, the field strength limits are based on average detector, however, the peak field strength of any emission shall not exceed the maximum permitted average limits, specified above by more than 20dB under any condition of modulation.

Limits of unwanted emission out of the restricted bands

Applicable To		Limit	
789033 D02 General UNII Test Procedure New Rules v02r01		Field Strength at 3m	
		PK:74 (dBµV/m)	AV:54 (dBµV/m)
Frequency Band	Applicable To	EIRP Limit	Equivalent Field Strength at 3m
5150~5250 MHz	15.407(b)(1)	PK:-27 (dBm/MHz)	PK:68.2(dBµV/m)
5250~5350 MHz	15.407(b)(2)		
5470~5725 MHz	15.407(b)(3)		
5725~5850 MHz	15.407(b)(4)(i)	PK:-27 (dBm/MHz) ^{*1} PK:10 (dBm/MHz) ^{*2} PK:15.6 (dBm/MHz) ^{*3} PK:27 (dBm/MHz) ^{*4}	PK: 68.2(dBµV/m) ^{*1} PK:105.2 (dBµV/m) ^{*2} PK: 110.8(dBµV/m) ^{*3} PK:122.2 (dBµV/m) ^{*4}
^{*1} beyond 75 MHz or more above of the band edge.		^{*2} below the band edge increasing linearly to 10 dBm/MHz at 25 MHz above.	
^{*3} below the band edge increasing linearly to a level of 15.6 dBm/MHz at 5 MHz above.		^{*4} from 5 MHz above or below the band edge increasing linearly to a level of 27 dBm/MHz at the band edge.	

Note:

The following formula is used to convert the equipment isotropic radiated power (eirp) to field strength:

$$E = \frac{1000000\sqrt{30P}}{3} \mu\text{V/m, where P is the eirp (Watts).}$$

4.1.2 Test Instruments

For Radiated Emission test:

Description & Manufacturer	Model No.	Serial No.	Calibrated Date	Calibrated Until
Test Receiver R&S	ESR3	102528	2023/2/10	2024/2/9
Spectrum Analyzer Keysight	N9020B	MY60112410	2022/3/13	2023/3/12
Software	ADT_Radiated_V8.7.08	NA	NA	NA
Boresight Antenna Tower & Turn Table Max-Full	MF-7802BS	MF780208530	NA	NA
Pre_Amplifier Agilent	8447D	2944A10636	2022/3/19	2023/3/18
LOOP ANTENNA Electro-Metrics	EM-6879	264	2022/3/18	2023/3/17
RF Coaxial Cable JYEBO	5D-FB	LOOPCAB-001	2022/12/19	2023/12/18
RF Coaxial Cable JYEBO	5D-FB	LOOPCAB-002	2022/12/19	2023/12/18
Pre_Amplifier EMCI	EMC330N	980538	2022/4/25	2023/4/24
Bilog Antenna Schwarzbeck	VULB 9168	9168-0842	2022/10/24	2023/10/23
RF Coaxial Cable COMMATE/PEWC	8D	966-5-1	2022/4/25	2023/4/24
RF Coaxial Cable COMMATE/PEWC	8D	966-5-2	2023/2/18	2024/2/17
RF Coaxial Cable COMMATE/PEWC	8D	966-5-3	2022/4/25	2023/4/24
Fixed attenuator Mini-Circuits	UNAT-5+	PAD-ATT5-02	2022/12/28	2023/12/27
Horn Antenna Schwarzbeck	BBHA 9120D	9120D-1819	2022/11/13	2023/11/12
Pre_Amplifier EMCI	EMC12630SE	980509	2022/4/25	2023/4/24
RF Coaxial Cable EMCI	EMC104-SM-SM-1500	180503	2022/4/25	2023/4/24
RF Coaxial Cable EMCI	EMC104-SM-SM-2000	180501	2022/4/25	2023/4/24
RF Coaxial Cable EMCI	EMC104-SM-SM-6000	180506	2022/4/25	2023/4/24
Pre_Amplifier EMCI	EMC184045SE	980387	2022/12/28	2023/12/27
Horn Antenna Schwarzbeck	BBHA 9170	9170-739	2022/11/13	2023/11/12
RF Cable-Frequency range: 1-40GHz EMCI	EMC102-KM-KM-1200	160924	2022/12/28	2023/12/27
RF Coaxial Cable EMCI	EMC-KM-KM-4000	200214	2023/2/20	2024/2/19

Note: 1. The test was performed in 966 Chamber No. 5.

2. The calibration interval of the above test instruments is 12 months and the calibrations are traceable to NML/ROC and NIST/USA.

3. Tested Date: 2023/2/23

For other test items:

DESCRIPTION & MANUFACTURER	MODEL NO.	SERIAL NO.	CALIBRATED DATE	CALIBRATED UNTIL
Spectrum Analyzer Keysight	N9020B	MY60112409	2022/3/11	2023/3/10
Attenuator WOKEN	MDCS18N-10	MDCS18N-10-01	2022/4/5	2023/4/4
Software	ADT_RF Test Software V6.6.5.4	NA	NA	NA

- NOTE:**
1. The test was performed in Oven room 2.
 2. The calibration interval of the above test instruments is 12 months and the calibrations are traceable to NML/ROC and NIST/USA.
 3. Tested Date: 2023/2/22

4.1.3 Test Procedures

Following FCC KDB 789033 D02 General UNII Test Procedures:

Radiated versus Conducted Measurements.

The unwanted emission limits in both the restricted and non-restricted bands are based on antenna-port conducted measurements in conjunction with cabinet emissions tests are permitted to demonstrate compliance.

The following steps was performed:

- a. Cabinet emissions measurements. Radiated measurement was performed to ensure that cabinet emissions are below the emission limits. For the cabinet-emission measurements the antenna was replaced by a termination matching the nominal impedance of the antenna.
- b. Conducted tests was performed using equipment that matches the nominal impedance of the antenna assembly used with the EUT.
- c. EIRP calculation. A value representative of an upper bound on out-of-band antenna gain (in dBi) shall be added to the measured antenna-port conducted emission power to compute EIRP within the specified measurement bandwidth. (For emissions in the restricted bands, additional calculations are required to convert EIRP to field strength at the specified distance.) The upper bound on antenna gain for a device with a single RF output shall be selected as the maximum in-band gain of the antenna across all operating bands or 2 dBi, whichever is greater.
- d. EIRP adjustments for multiple outputs. (Follow the procedures specified in FCC KDB Publication 662911)
- e. For all of Radiation emission test

For Radiated emission below 30MHz

- a. The EUT was placed on the top of a rotating table 0.8 meters above the ground at a 3 meter chamber room. The table was rotated 360 degrees to determine the position of the highest radiation.
- b. The EUT was set 3 meters away from the interference-receiving antenna, which was mounted on the top of a variable-height antenna tower.
- c. Parallel, perpendicular, and ground-parallel orientations of the antenna are set to make the measurement.
- d. For each suspected emission, the EUT was arranged to its worst case and the rotatable table was turned from 0 degrees to 360 degrees to find the maximum reading.
- e. The test-receiver system was set to Quasi-Peak Detect Function and Specified Bandwidth with Maximum Hold Mode.

NOTE:

1. The resolution bandwidth and video bandwidth of test receiver/spectrum analyzer is 9kHz at frequency below 30MHz.

For Radiated emission above 30MHz

- a. The EUT was placed on the top of a rotating table 0.8 meters (for 30MHz ~ 1GHz) / 1.5 meters (for above 1GHz) above the ground at 3 meter chamber room for test. The table was rotated 360 degrees to determine the position of the highest radiation.
- b. The EUT was set 3 meters away from the interference-receiving antenna, which was mounted on the top of a variable-height antenna tower.
- c. The height of antenna is varied from one meter to four meters above the ground to determine the maximum value of the field strength. Both horizontal and vertical polarizations of the antenna are set to make the measurement.
- d. For each suspected emission, the EUT was arranged to its worst case and then the antenna was tuned to heights from 1 meter to 4 meters and the rotatable table was turned from 0 degrees to 360 degrees to find the maximum reading.
- e. The test-receiver system was set to quasi-peak detect function and specified bandwidth with maximum hold mode when the test frequency is below 1 GHz.
- f. The test-receiver system was set to peak and average detects function and specified bandwidth with maximum hold mode when the test frequency is above 1 GHz. If the peak reading value also meets average limit, measurement with the average detector is unnecessary.

Note:

1. The resolution bandwidth and video bandwidth of test receiver/spectrum analyzer is 120kHz for Quasi-peak detection (QP) at frequency below 1GHz.
2. The resolution bandwidth of test receiver/spectrum analyzer is 1 MHz and the video bandwidth is 3 MHz for Peak detection (PK) at frequency above 1GHz.
3. The resolution bandwidth of test receiver/spectrum analyzer is 1MHz and the video bandwidth is $\geq 1/T$ (Duty cycle < 98%) or 10Hz (Duty cycle $\geq 98\%$) for Average detection (AV) at frequency above 1GHz.
4. All modes of operation were investigated and the worst-case emissions are reported.

4.1.4 Deviation from Test Standard

No deviation.

4.1.5 Test Setup

For Conducted Configuration:

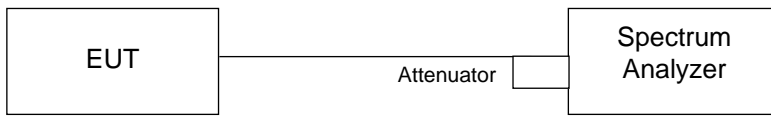

For Radiated Configuration:

For Radiated emission below 30MHz

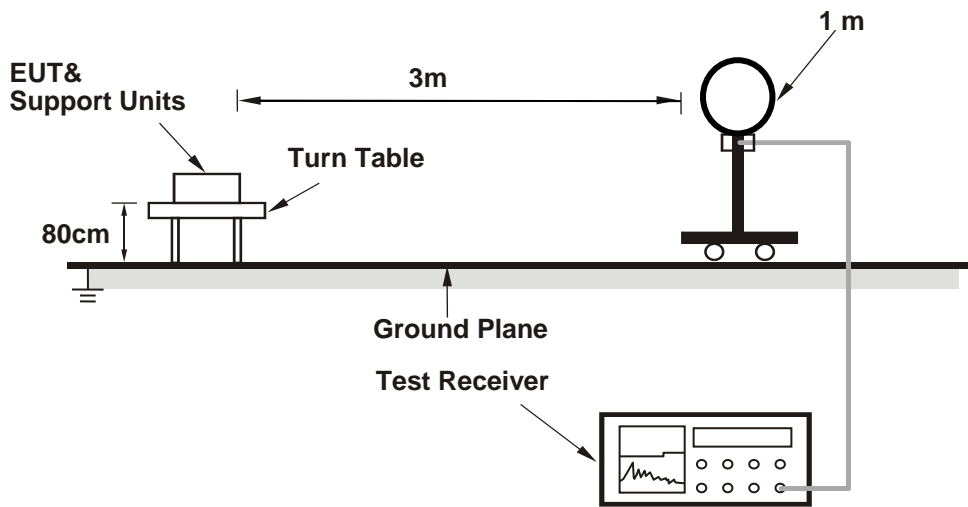

For Radiated emission 30MHz to 1GHz

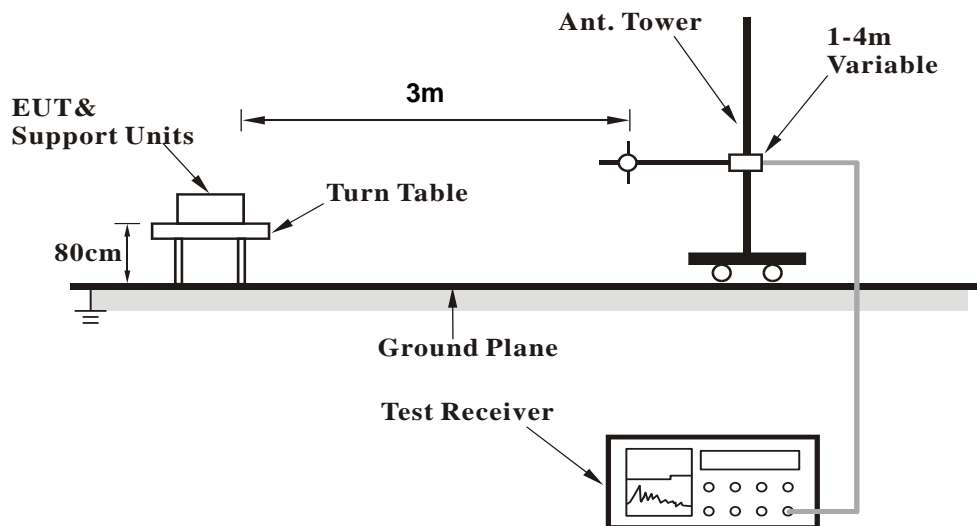

For Radiated emission above 1GHz

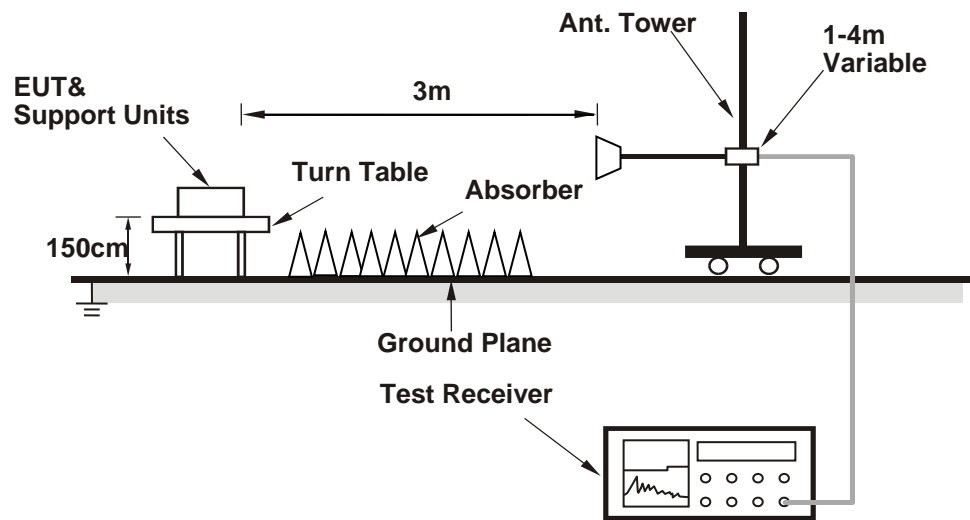

For the actual test configuration, please refer to the attached file (Test Setup Photo).

4.1.6 EUT Operating Conditions

- Connected the EUT with the Laptop which is placed on the testing table.
- Controlling software (QRCT 4.0.00159.1) has been activated to set the EUT under transmission condition continuously at specific channel frequency.

4.1.7 Test Results (Conducted Measurement)

Radiated versus Conducted Measurement

For Radiated measurement:

The level of unwanted emissions was measured when radiated by the cabinet or structure of the equipment with the antenna connector(s) terminated by a specified load (cabinet radiation)

For Conducted measurement:

The level of unwanted emissions was measured as their power in a specified load (conducted spurious emissions).

Conducted Emission Convert Formula

- a. Emission Level (dBuV/m) = EIRP Level (dBm) – 20log(d) + 104.8
d = measurement distance in 3 meters.
- b. EIRP Level (dBm) = Raw Value(dBm) + Correction Factor(dB)
- c. Correction Factor is directional gain, and the composite gain will be used when signal support the correlated signal
For the out of band spurious the gain for the specific band may have been used rather than the highest gain across all bands.
For the band edge the gain for the specific band may have been used.

Notes:

1. In restricted bands below 1000 MHz, add upper bound on ground plane reflection:
For f = 30 – 1000 MHz, add 4.7 dB.
2. The conducted emission test was considered some factor to compute test result.

For Mode 1

Above 1GHz Data:

Conducted spurious emission table

No.	Frequency (MHz)	Emission Level (dBuV/m)	Limit (dBuV/m)	Margin (dB)	Raw Value (dBm)		Correction Factor (dB)	EIRP Level (dBm)
					Chain0	Chain1		
1	4823.43	61.24 PK	74	-12.76	-43.69	-47.55	8.17	-34.02
2	4823.43	52.26 AV	54	-1.74	-52.37	-57.35	8.17	-43.00
3	11146.87	58.89 PK	74	-15.11	-47.56	-47.54	8.17	-36.37
4	11176.56	43.72 AV	54	-10.28	-63.12	-62.35	8.17	-51.54
5	#16735.81	49.77 PK	68.2	-18.43	-56.41	-56.95	8.17	-45.49

Remarks:

1. Margin value = Emission Level – Limit value
2. The other emission levels were very low against the limit.
3. " # " : The frequency is out of the restricted band.

Chain 0

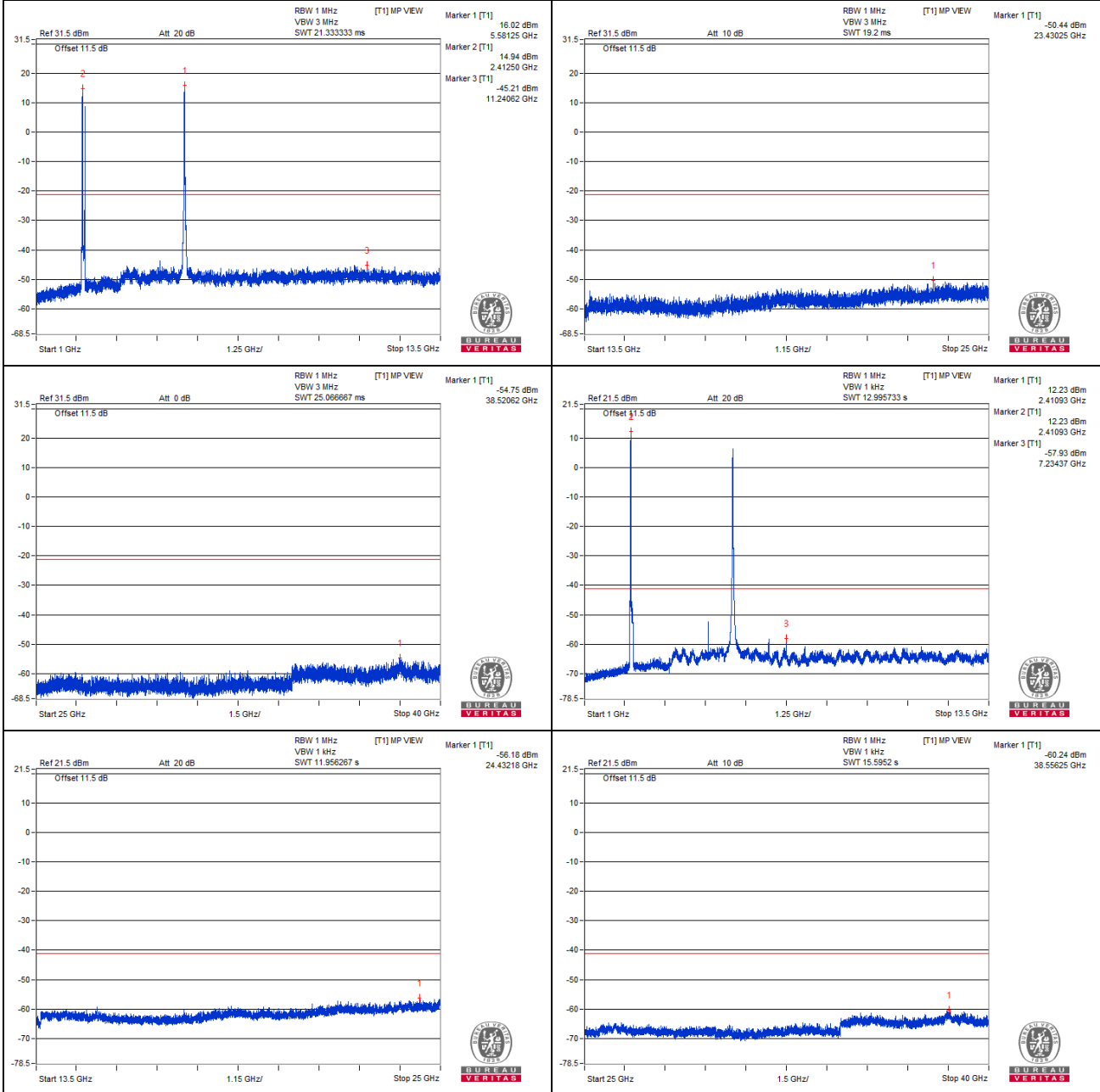

Chain 1

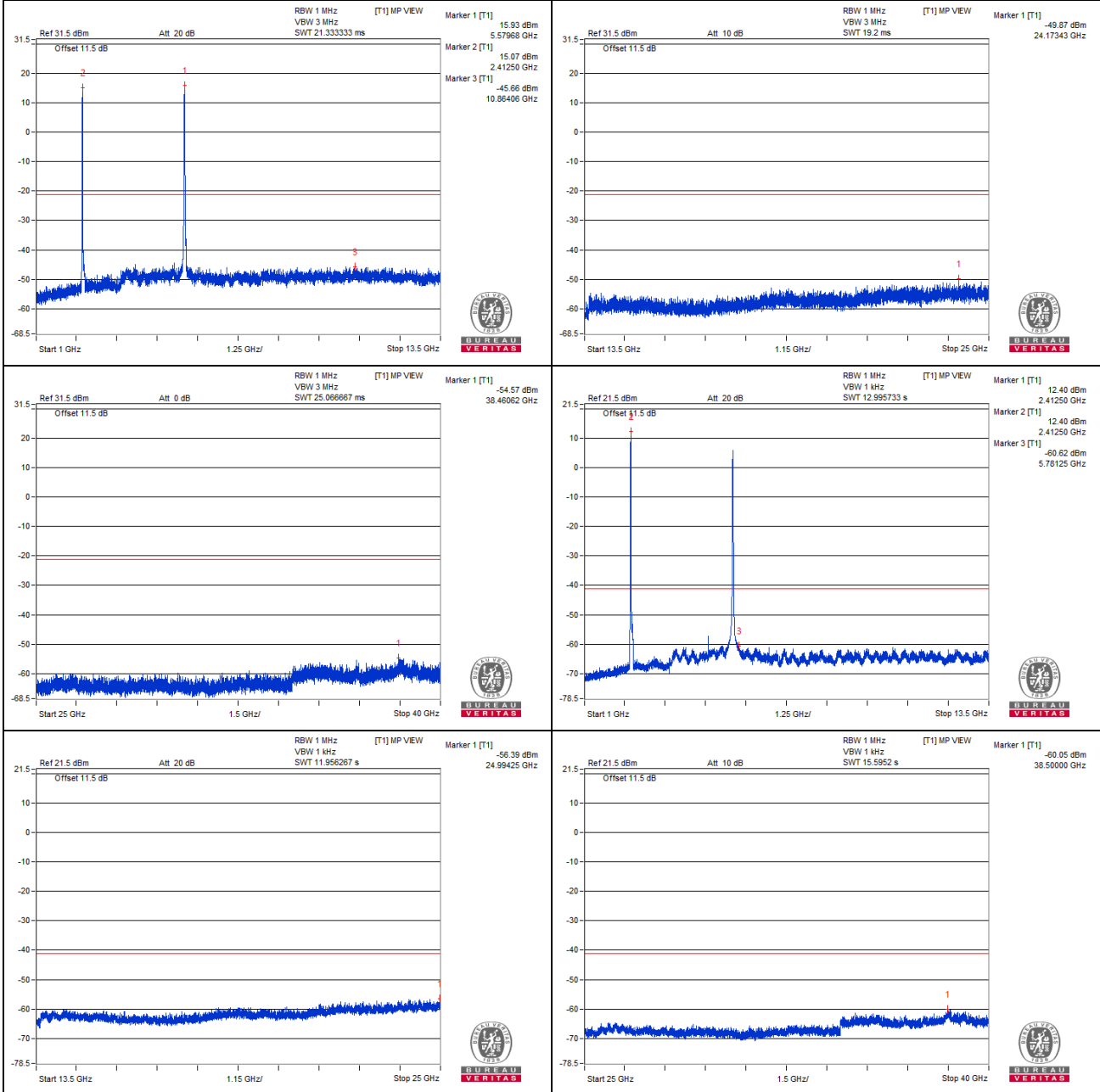

Below 1GHz Data:

Conducted spurious emission table

No.	Frequency (MHz)	Emission Level (dBuV/m)	Limit (dBuV/m)	Margin (dB)	Raw Value (dBm)		Correction Factor (dB)	EIRP Level (dBm)
					Chain0	Chain1		
1	39.33	36.8	40	-3.2	-69.52	-69.76	8.17	-58.46
2	212.48	37.36	43.5	-6.14	-68.33	-69.99	8.17	-57.90
3	298.08	37.69	46	-8.31	-70.6	-67.45	8.17	-57.57
4	581.08	37.61	46	-8.39	-68.94	-68.73	8.17	-57.65
5	758.34	38.53	46	-7.47	-68.57	-67.34	8.17	-56.73
6	879.23	39.47	46	-6.53	-68.68	-65.74	8.17	-55.79

Remarks:

1. Margin value = Emission Level – Limit value
2. The other emission levels were very low against the limit.

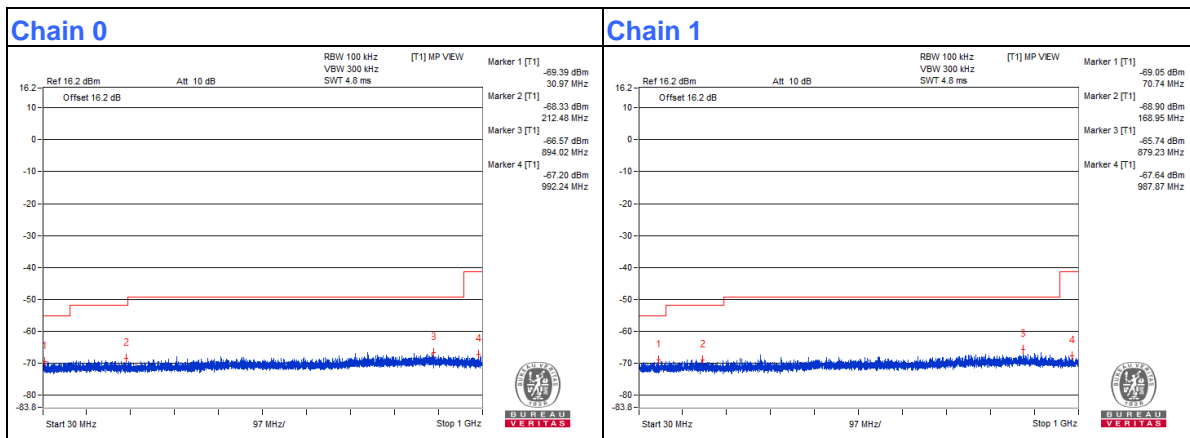

For Mode 2

Above 1GHz Data:

No.	Frequency (MHz)	Emission Level (dBuV/m)	Limit (dBuV/m)	Margin (dB)	Raw Value (dBm)		Correction Factor (dB)	EIRP Level (dBm)
					Chain0	Chain1		
1	4823.43	59.81 PK	74	-14.19	-48.15	-45.51	8.17	-35.45
2	4823.43	52.19 AV	54	-1.81	-57.55	-52.4	8.17	-43.07
3	12334.37	58.07 PK	74	-15.93	-47.87	-48.93	8.17	-37.19
4	12348.43	44.01 AV	54	-9.99	-62.07	-62.83	8.17	-51.25
5	18522.62	50.75 PK	74	-23.25	-54.71	-56.97	8.17	-44.51
6	18528.37	45.4 AV	54	-8.6	-62.23	-60.1	8.17	-49.86

Remarks:

1. Margin value = Emission Level – Limit value
2. The other emission levels were very low against the limit.

Chain 0

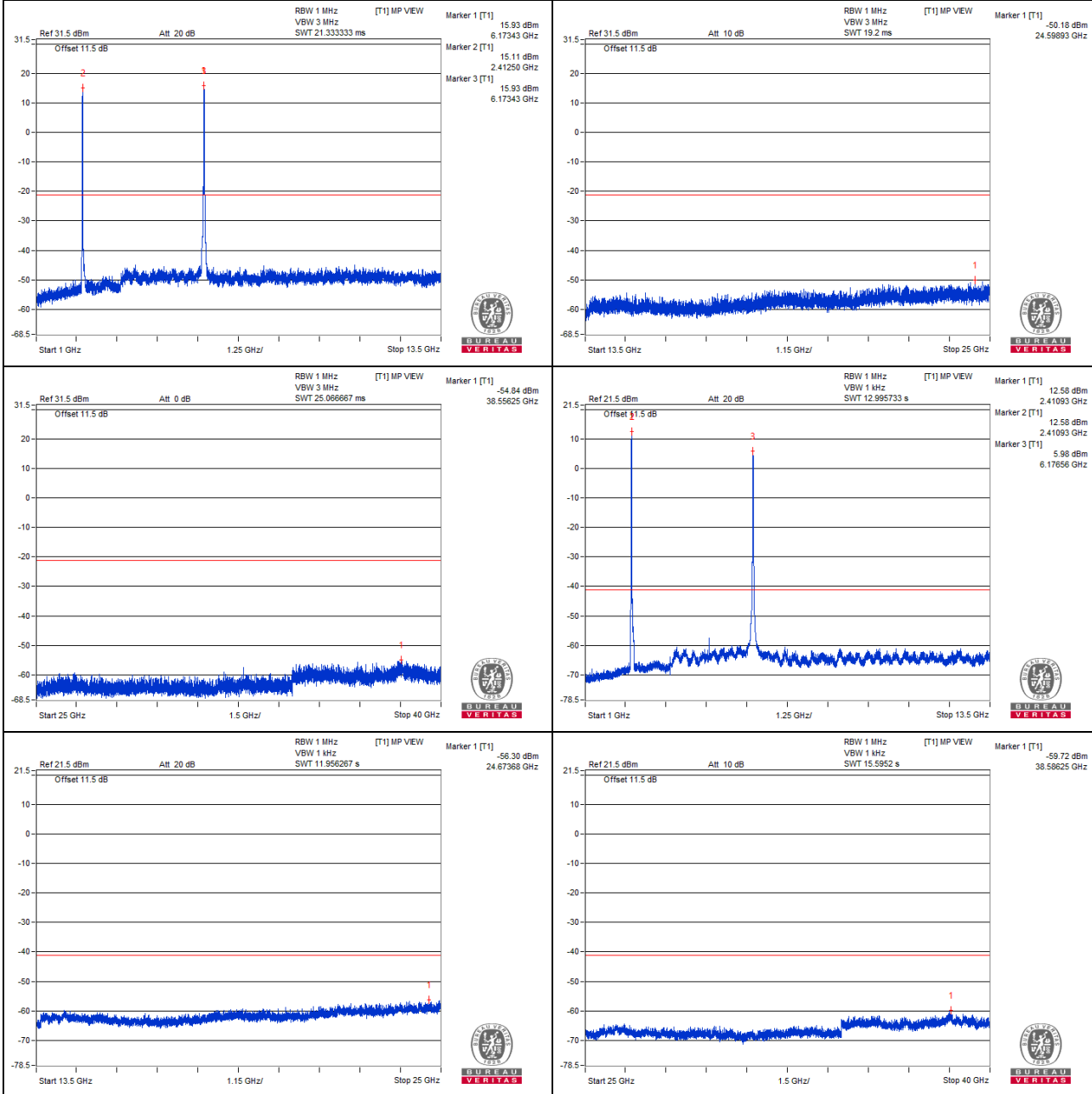

Chain 1

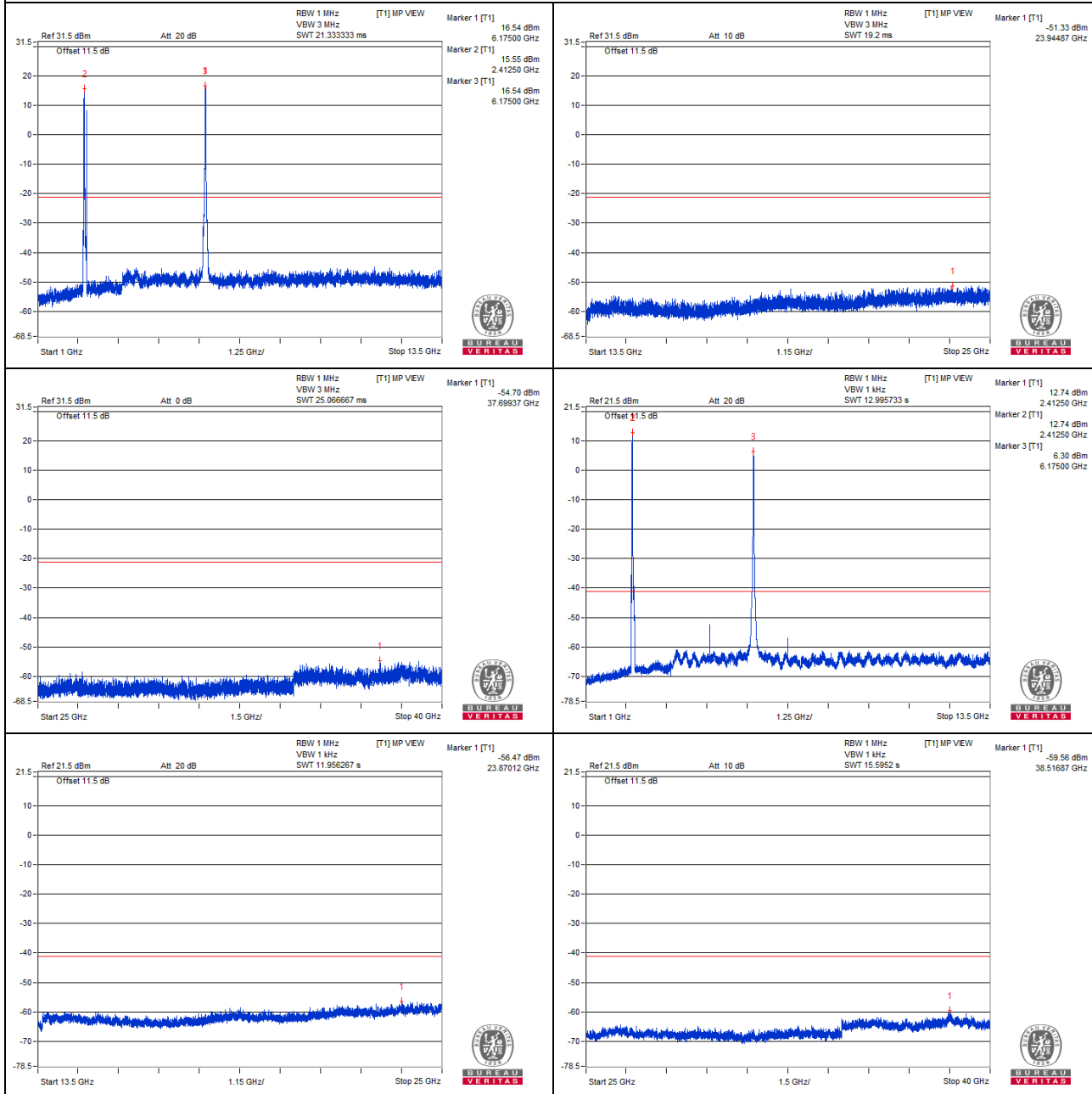

Below 1GHz Data:

Conducted spurious emission table

No.	Frequency (MHz)	Emission Level (dBuV/m)	Limit (dBuV/m)	Margin (dB)	Raw Value (dBm)		Correction Factor (dB)	EIRP Level (dBm)
					Chain0	Chain1		
1	77.65	36.57	40	-3.43	-69.71	-70.03	8.17	-58.69
2	163.37	36.91	43.5	-6.59	-69.98	-69.13	8.17	-58.35
3	391.2	37.67	46	-8.33	-70.51	-67.53	8.17	-57.59
4	556.71	37.7	46	-8.3	-69.24	-68.3	8.17	-57.56
5	775.08	39.05	46	-6.95	-68.44	-66.55	8.17	-56.21
6	899.12	38.91	46	-7.09	-68.45	-66.77	8.17	-56.35

Remarks:

1. Margin value = Emission Level – Limit value
2. The other emission levels were very low against the limit.

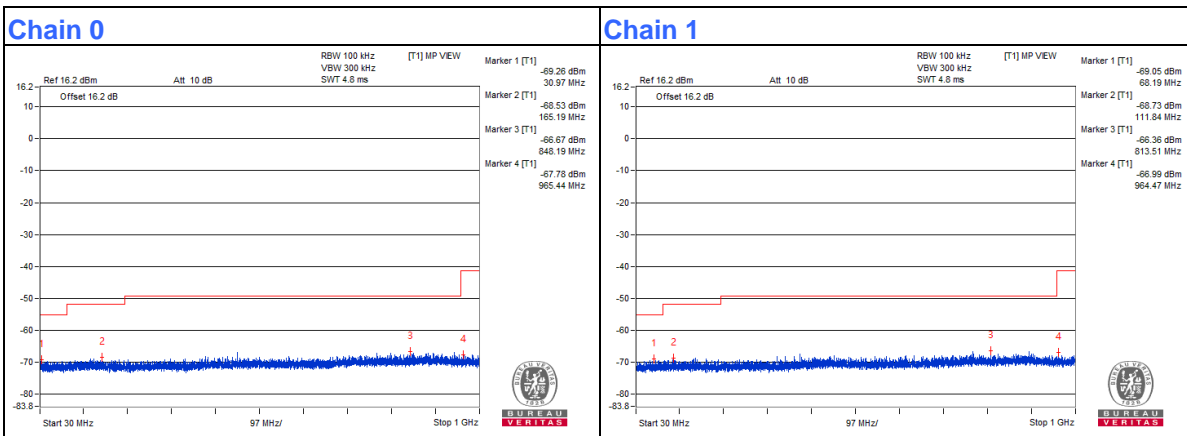

For Mode 3

Above 1GHz Data:

No.	Frequency (MHz)	Emission Level (dBuV/m)	Limit (dBuV/m)	Margin (dB)	Raw Value (dBm)		Correction Factor (dB)	EIRP Level (dBm)
					Chain0	Chain1		
1	4860.93	58.75 PK	74	-15.25	-48.2	-47.24	8.17	-36.51
2	4860.93	43.82 AV	54	-10.18	-64.15	-61.49	8.17	-51.44
3	7335.93	57.38 PK	74	-16.62	-47.88	-50.69	8.17	-37.88
4	7329.68	41.85 AV	54	-12.15	-64.59	-64.6	8.17	-53.41
5	11145.31	58.98 PK	74	-15.02	-48.64	-46.54	8.17	-36.28
6	11143.75	43.25 AV	54	-10.75	-62.46	-64.08	8.17	-52.01
7	#16751.62	48.84 PK	68.2	-19.36	-58.47	-56.88	8.17	-46.42

Remarks:

1. Margin value = Emission Level – Limit value
2. The other emission levels were very low against the limit.
3. " # " : The frequency is out of the restricted band.

Chain 0

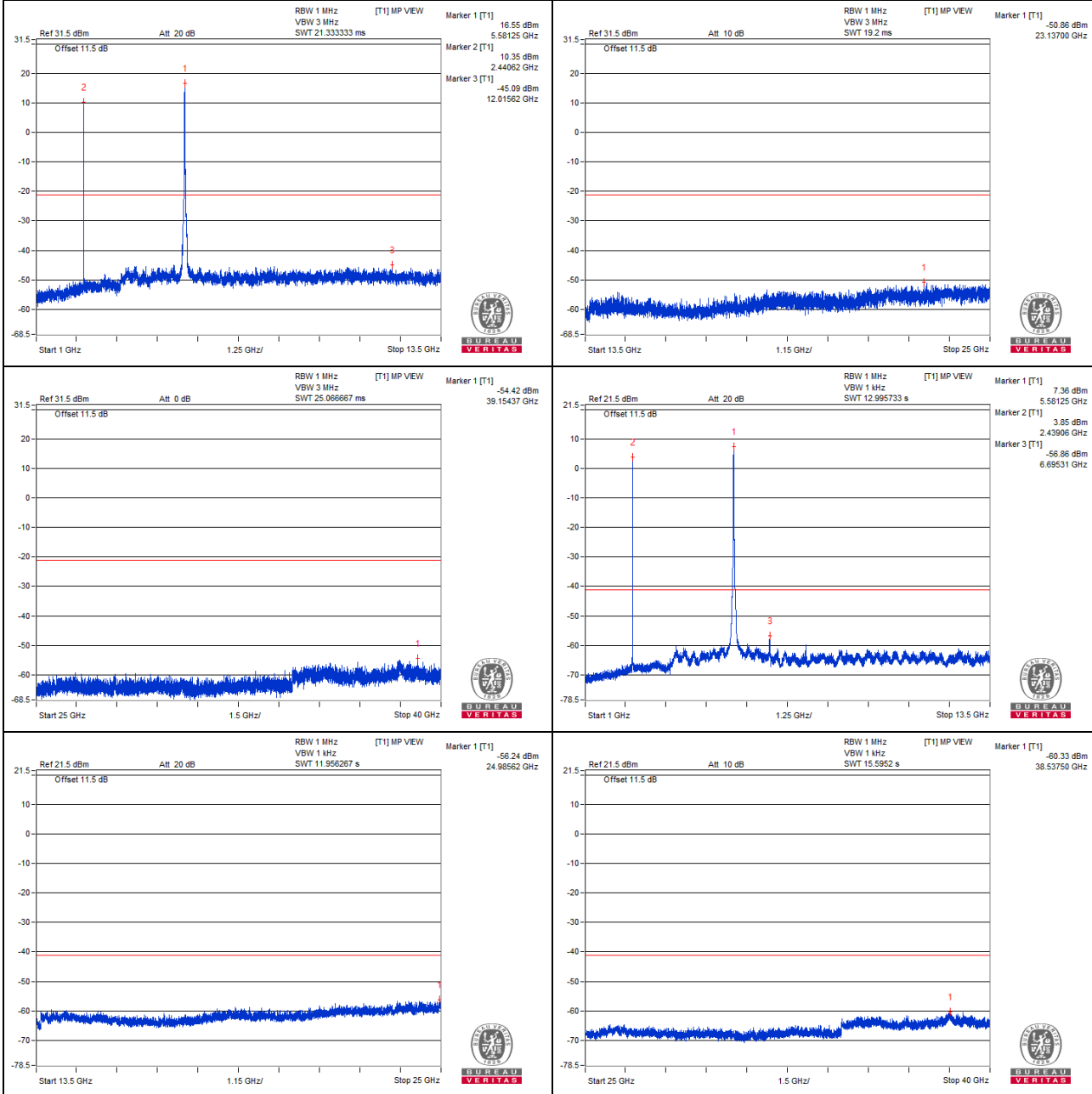

Chain 1

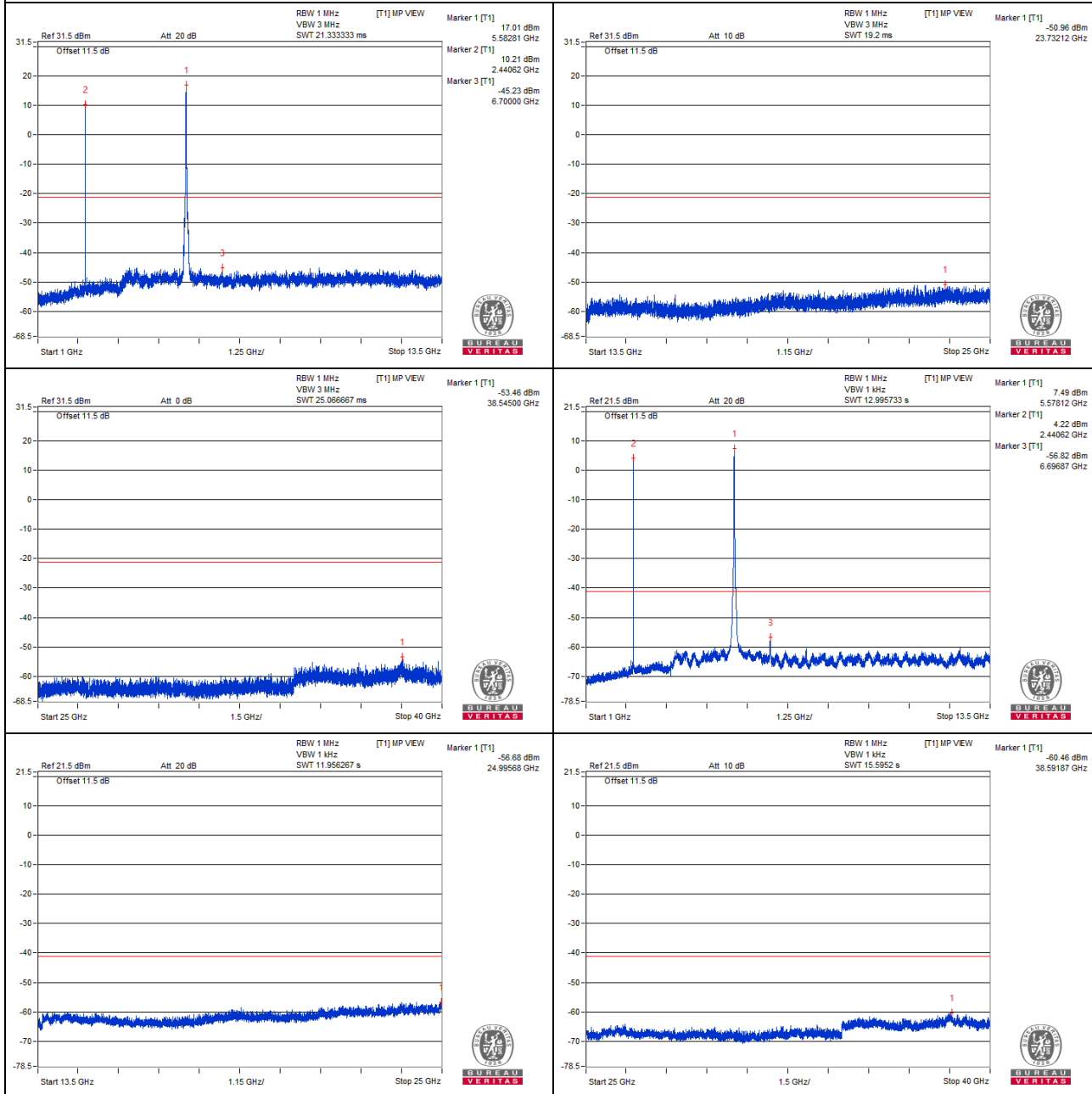

Below 1GHz Data:

Conducted spurious emission table

No.	Frequency (MHz)	Emission Level (dBuV/m)	Limit (dBuV/m)	Margin (dB)	Raw Value (dBm)		Correction Factor (dB)	EIRP Level (dBm)
					Chain0	Chain1		
1	77.77	36.49	40	-3.51	-69.91	-70	8.17	-58.77
2	166.16	36.98	43.5	-6.52	-69.57	-69.36	8.17	-58.28
3	307.29	36.94	46	-9.06	-69.3	-69.7	8.17	-58.32
4	585.81	37.86	46	-8.14	-68.34	-68.83	8.17	-57.40
5	713.97	38.54	46	-7.46	-69.04	-67	8.17	-56.72
6	917.67	39.06	46	-6.94	-68.96	-66.22	8.17	-56.20

Remarks:

1. Margin value = Emission Level – Limit value
2. The other emission levels were very low against the limit.

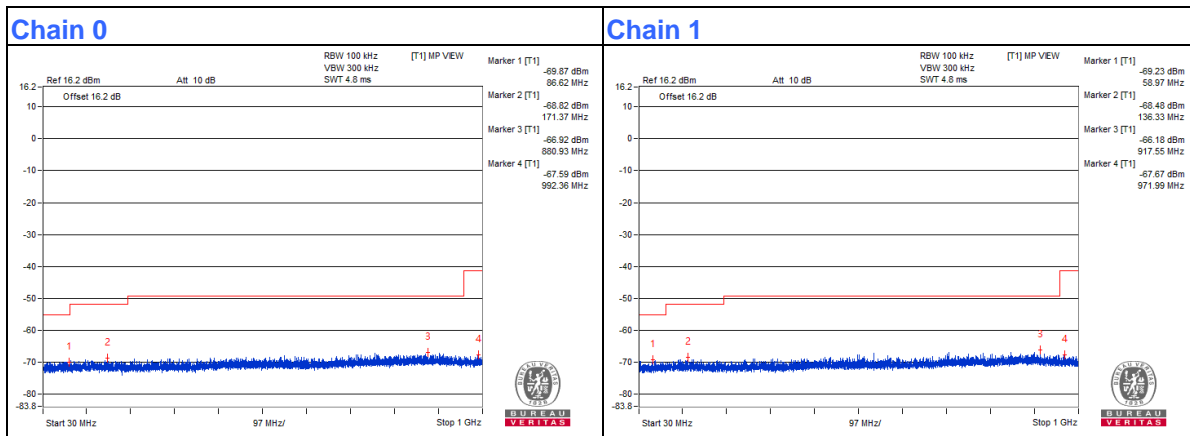

For Mode 4

Above 1GHz Data:

No.	Frequency (MHz)	Emission Level (dBuV/m)	Limit (dBuV/m)	Margin (dB)	Raw Value (dBm)		Correction Factor (dB)	EIRP Level (dBm)
					Chain0	Chain1		
1	4884.37	58.9 PK	74	-15.1	-49.5	-46.2	8.17	-36.36
2	4881.25	43.62 AV	54	-10.38	-63.52	-62.22	8.17	-51.64
3	7325	57.97 PK	74	-16.03	-47.85	-49.19	8.17	-37.29
4	7337.5	42.32 AV	54	-11.68	-63.61	-64.7	8.17	-52.94
5	12342.18	58.92 PK	74	-15.08	-47.28	-47.77	8.17	-36.34
6	12350	46.24 AV	54	-7.76	-59.6	-60.89	8.17	-49.02
7	18511.12	50.86 PK	74	-23.14	-57.63	-54.2	8.17	-44.40
8	18544.18	45.44 AV	54	-8.56	-59.73	-62.8	8.17	-49.82

Remarks:

1. Margin value = Emission Level – Limit value
2. The other emission levels were very low against the limit.

Chain 0

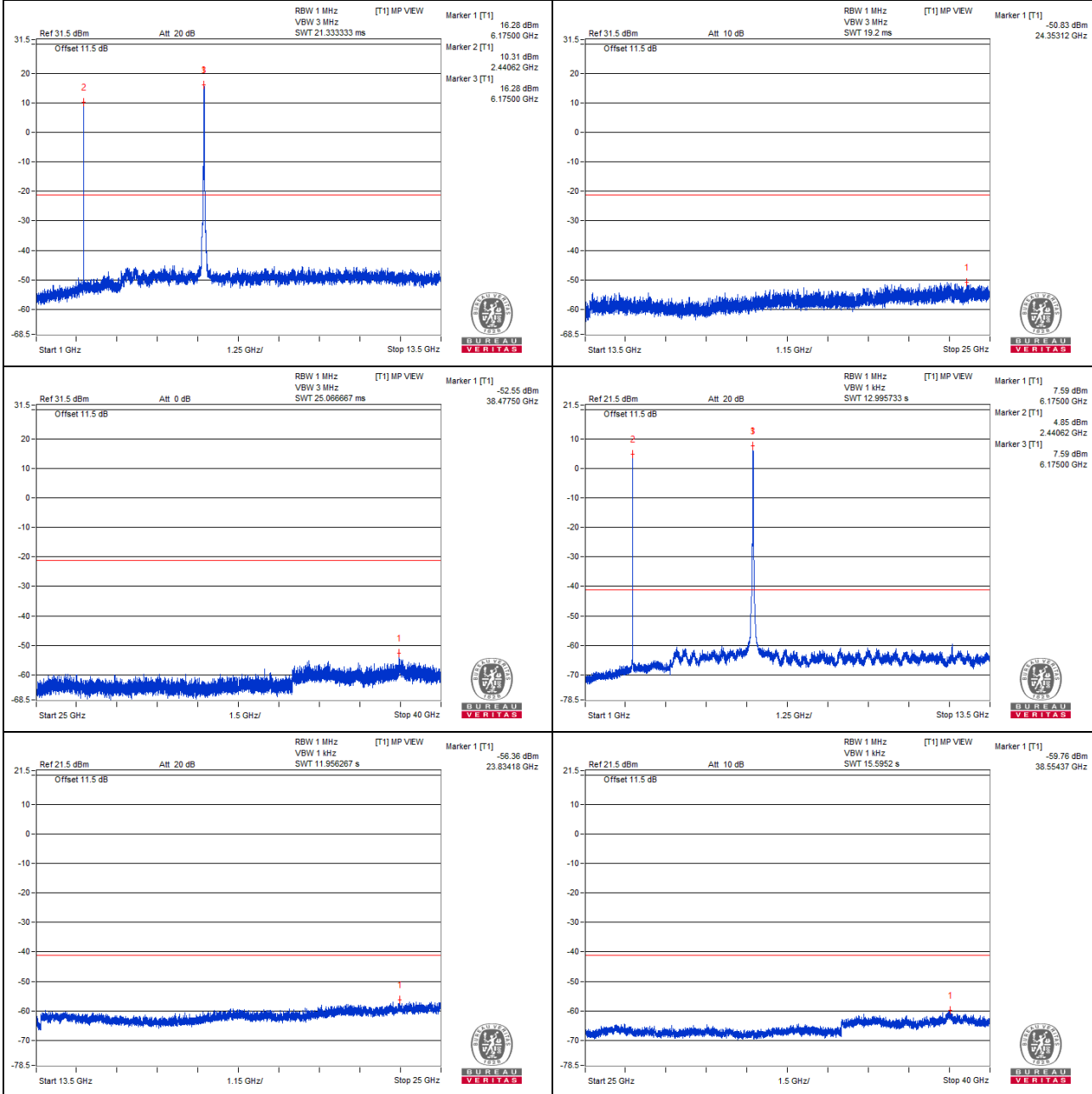

Chain 1

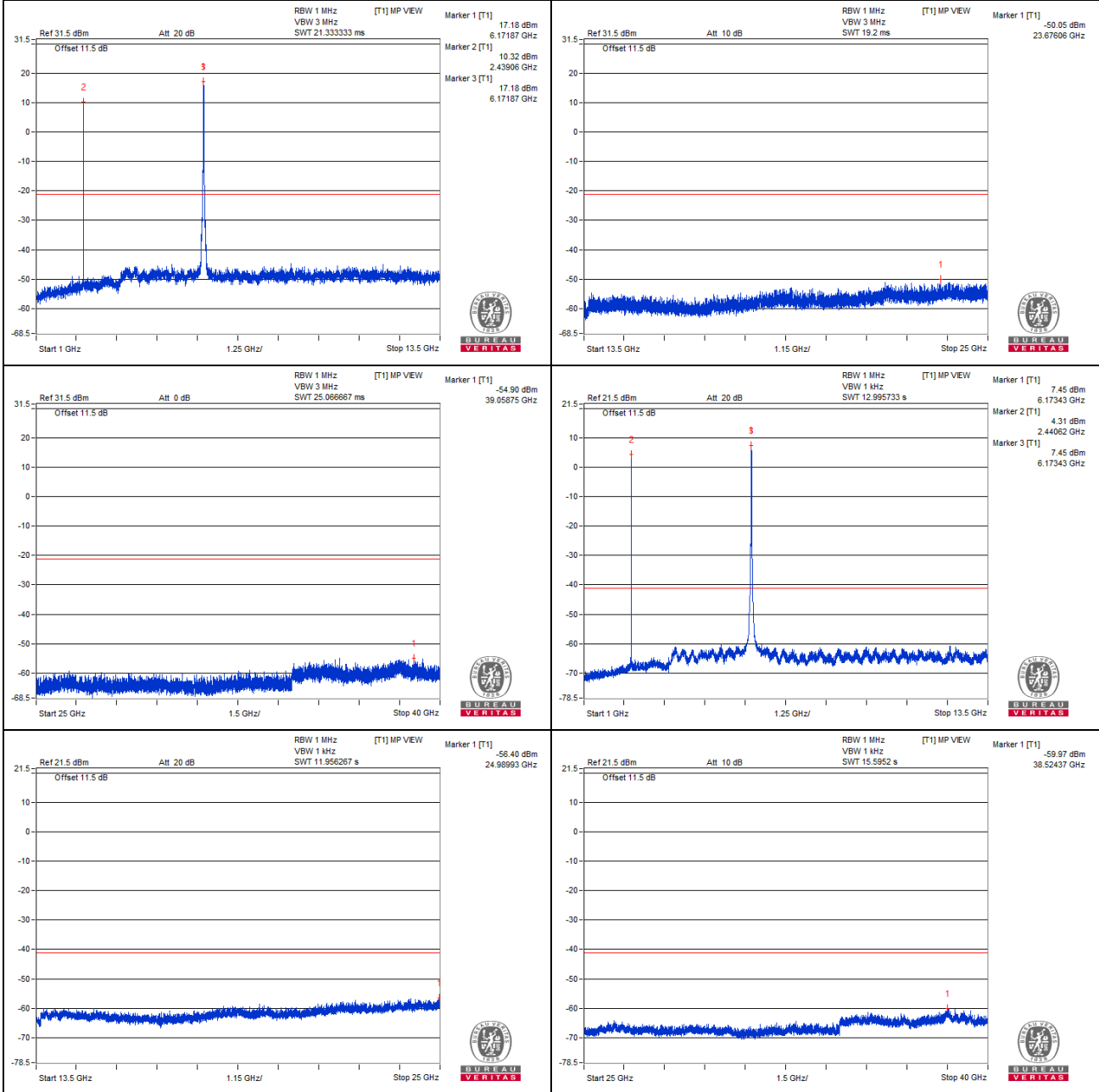

Below 1GHz Data:

Conducted spurious emission table

No.	Frequency (MHz)	Emission Level (dBuV/m)	Limit (dBuV/m)	Margin (dB)	Raw Value (dBm)		Correction Factor (dB)	EIRP Level (dBm)
					Chain0	Chain1		
1	85.77	36.78	40	-3.22	-70.25	-69.14	8.17	-58.48
2	133.54	36.79	43.5	-6.71	-68.64	-70.97	8.17	-58.47
3	218.05	36.91	46	-9.09	-68.27	-71.32	8.17	-58.35
4	492.81	37.65	46	-8.35	-67.68	-70.29	8.17	-57.61
5	780.9	38.31	46	-7.69	-68.14	-68.12	8.17	-56.95
6	856.92	38.65	46	-7.35	-69.78	-66.43	8.17	-56.61

Remarks:

1. Margin value = Emission Level – Limit value
2. The other emission levels were very low against the limit.

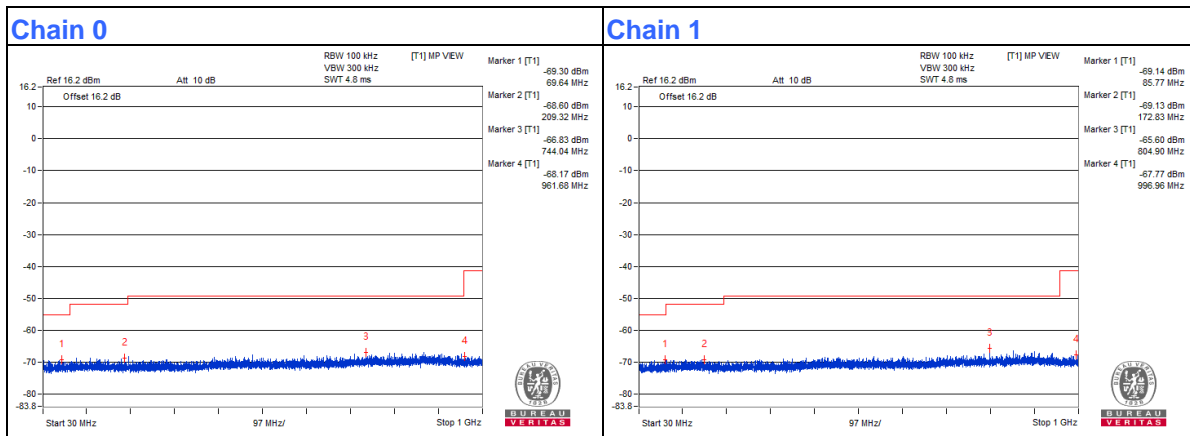

For Mode 5

Above 1GHz Data:

No.	Frequency (MHz)	Emission Level (dBuV/m)	Limit (dBuV/m)	Margin (dB)	Raw Value (dBm)		Correction Factor (dB)	EIRP Level (dBm)
					Chain0	Chain1		
1	4879.68	59.43 PK	74	-14.57	-46.06	-48.23	8.17	-35.83
2	4879.68	45.19 AV	54	-8.81	-61.04	-61.47	8.17	-50.07
3	7337.5	58.46 PK	74	-15.54	-48.88	-47.24	8.17	-36.80
4	7300	43.05 AV	54	-10.95	-64.48	-62.52	8.17	-52.21
5	#10404.68	59.26 PK	68.2	-8.94	-46.81	-47.58	8.17	-36.00
6	15617.43	48.82 PK	74	-25.18	-58.77	-56.71	8.17	-46.44
7	15600.18	45.57 AV	54	-8.43	-61.04	-60.7	8.17	-49.69
8	11159.37	59.94 PK	74	-14.06	-47.95	-45.41	8.17	-35.32
9	11154.68	44.53 AV	54	-9.47	-62.34	-61.52	8.17	-50.73
10	#16750.18	49.05 PK	68.2	-19.15	-56.29	-58.88	8.17	-46.21

Remarks:

1. Margin value = Emission Level – Limit value
2. The other emission levels were very low against the limit.
3. " # " : The frequency is out of the restricted band.

Chain 0

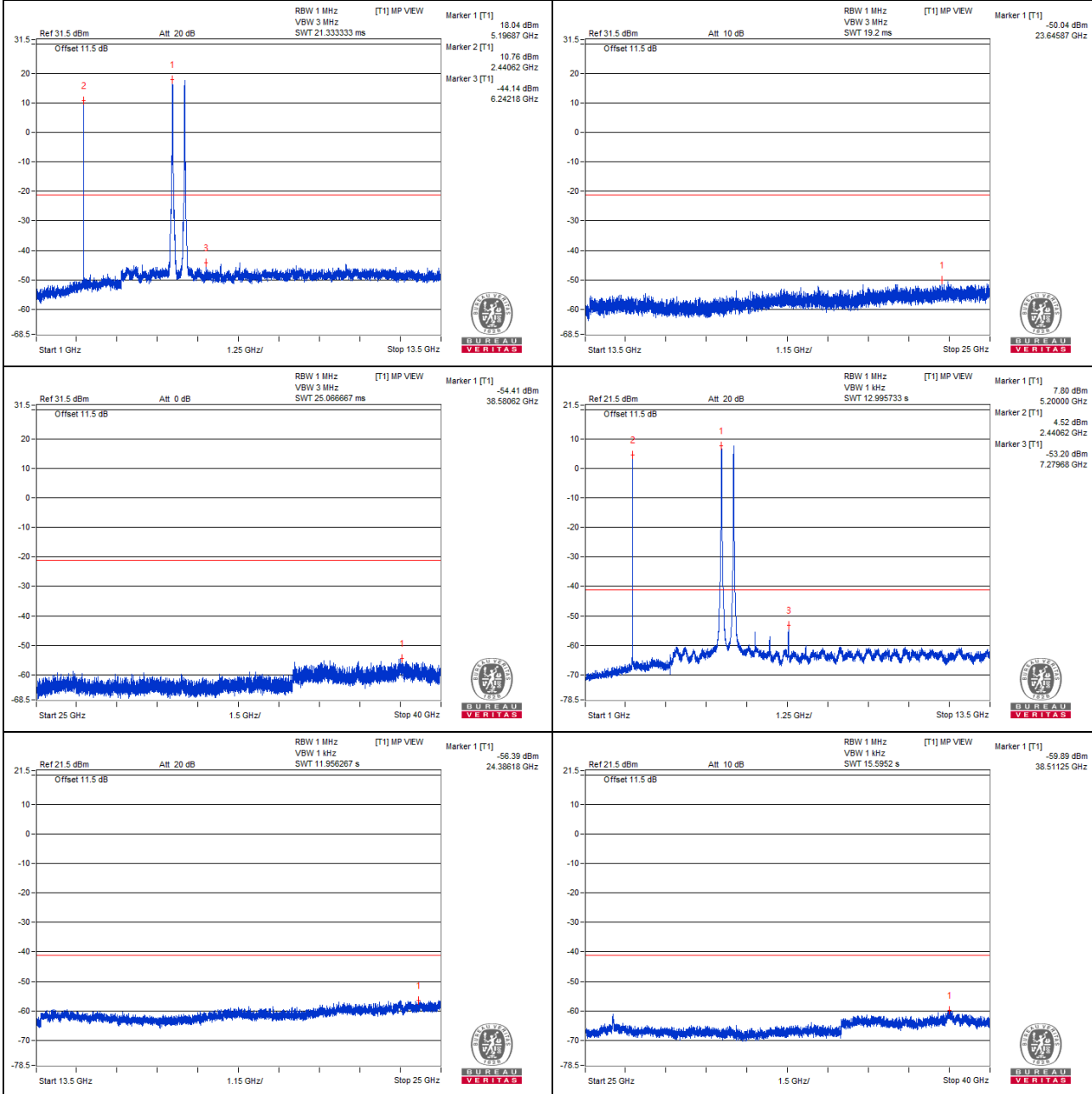

Chain 1

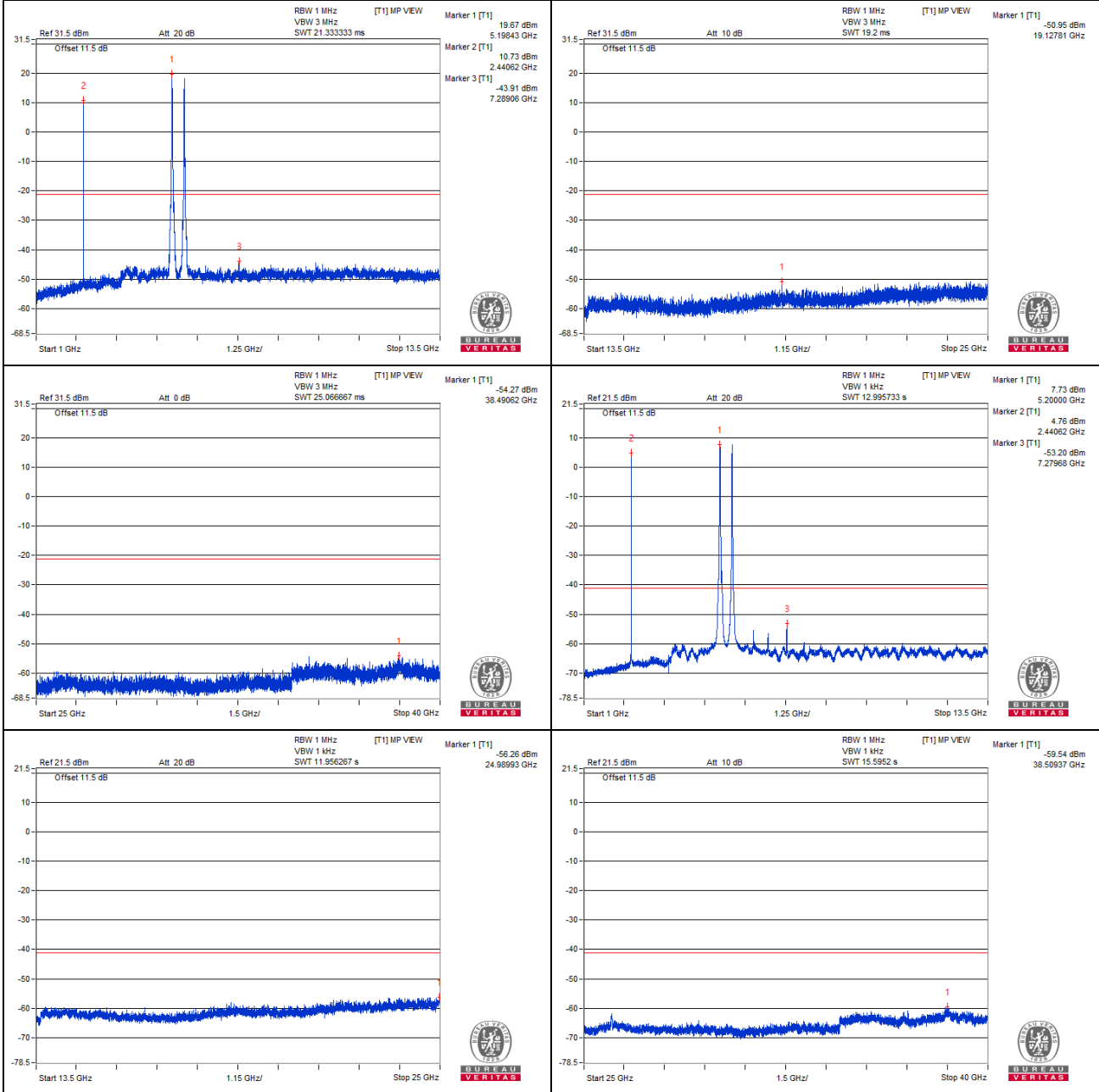

Below 1GHz Data:

Conducted spurious emission table

No.	Frequency (MHz)	Emission Level (dBuV/m)	Limit (dBuV/m)	Margin (dB)	Raw Value (dBm)		Correction Factor (dB)	EIRP Level (dBm)
					Chain0	Chain1		
1	42.61	36.22	40	-3.78	-69.96	-70.49	8.17	-59.04
2	139.24	36.76	43.5	-6.74	-70.15	-69.26	8.17	-58.50
3	264.49	37.23	46	-8.77	-68.04	-70.83	8.17	-58.03
4	529.67	37.53	46	-8.47	-68.21	-69.74	8.17	-57.73
5	729.61	38.01	46	-7.99	-67.75	-69.24	8.17	-57.25
6	866.98	39.52	46	-6.48	-67.99	-66.07	8.17	-55.74

Remarks:

1. Margin value = Emission Level – Limit value
2. The other emission levels were very low against the limit.

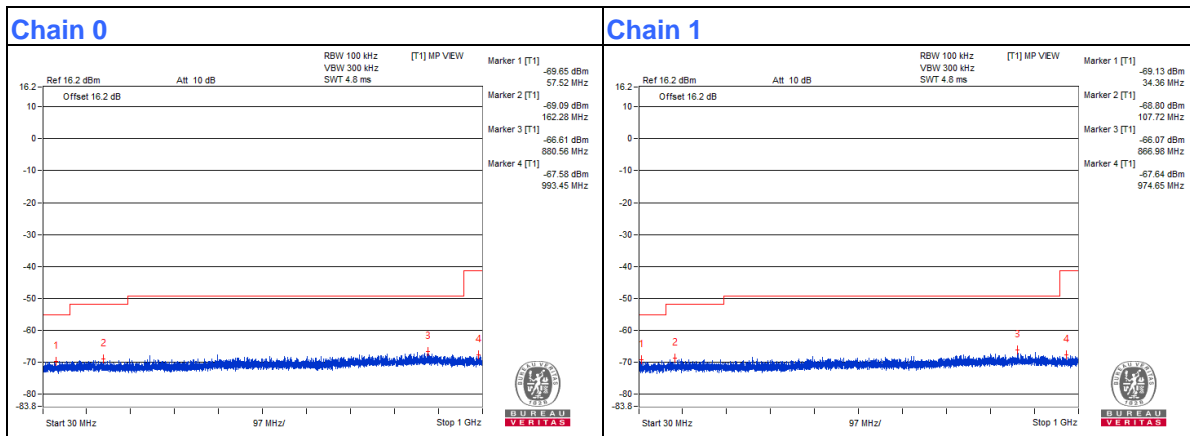

For Mode 6

Above 1GHz Data:

No.	Frequency (MHz)	Emission Level (dBuV/m)	Limit (dBuV/m)	Margin (dB)	Raw Value (dBm)		Correction Factor (dB)	EIRP Level (dBm)
					Chain0	Chain1		
1	4873.43	59.62 PK	74	-14.38	-45.87	-48.05	8.17	-35.64
2	4864.06	45.42 AV	54	-8.58	-60.81	-61.24	8.17	-49.84
3	7307.81	58.85 PK	74	-15.15	-47.11	-48.12	8.17	-36.41
4	7301.56	43.25 AV	54	-10.75	-63.01	-63.37	8.17	-52.01
5	#10381.25	59.51 PK	68.2	-8.69	-47.8	-46.2	8.17	-35.75
6	15618.87	49.68 PK	74	-24.32	-57.54	-56.1	8.17	-45.58
7	15590.12	45.75 AV	54	-8.25	-61.37	-60.1	8.17	-49.51
8	12364.06	59.37 PK	74	-14.63	-47.73	-46.5	8.17	-35.89
9	12346.87	45.23 AV	54	-8.77	-60.17	-62.59	8.17	-50.03
10	18511.12	50.58 PK	74	-23.42	-56.85	-55.05	8.17	-44.68
11	18514	46.02 AV	54	-7.98	-62.64	-58.96	8.17	-49.24

Remarks:

1. Margin value = Emission Level – Limit value
2. The other emission levels were very low against the limit.
3. " # " : The frequency is out of the restricted band.

Chain 0

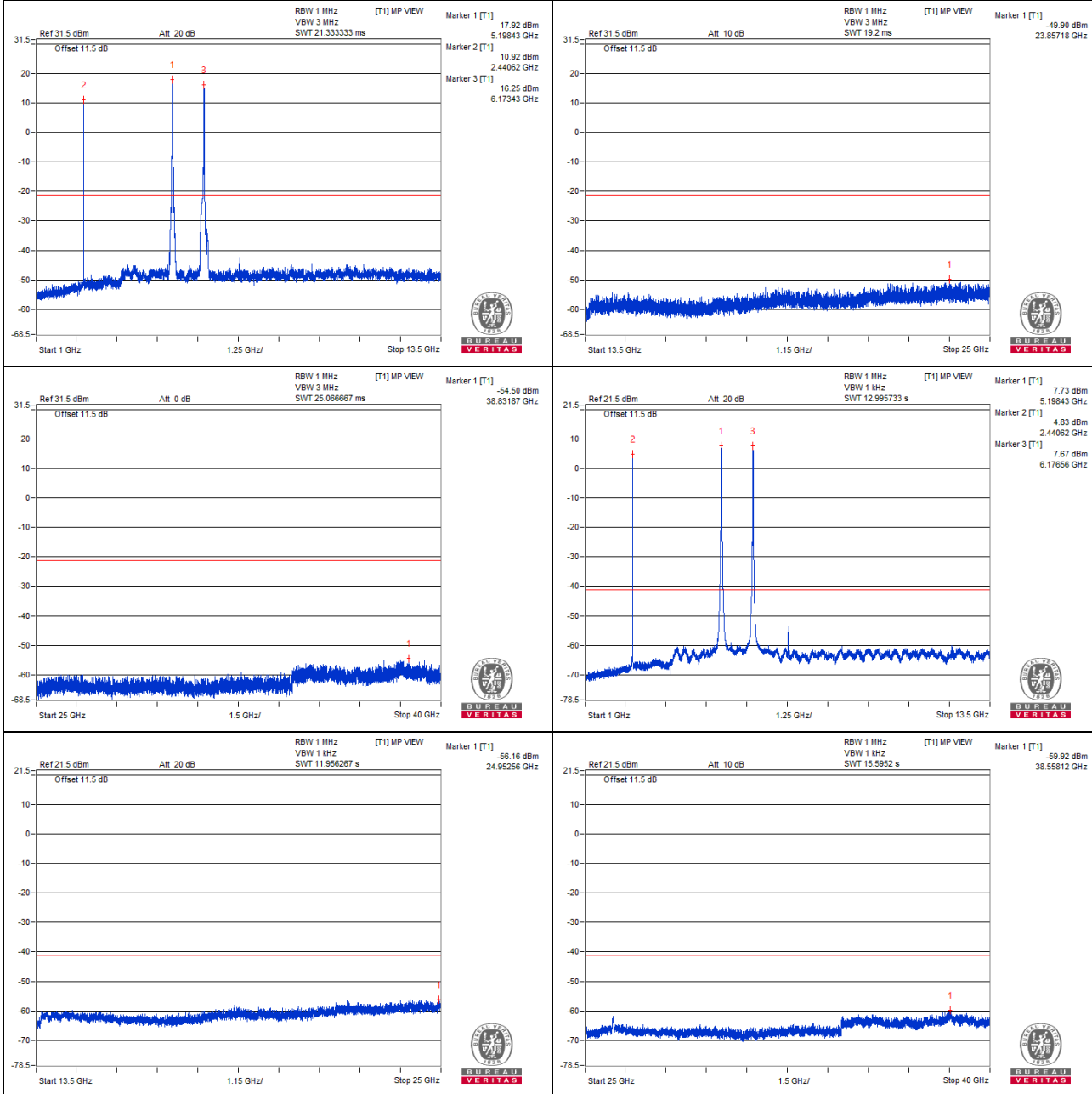

Chain 1

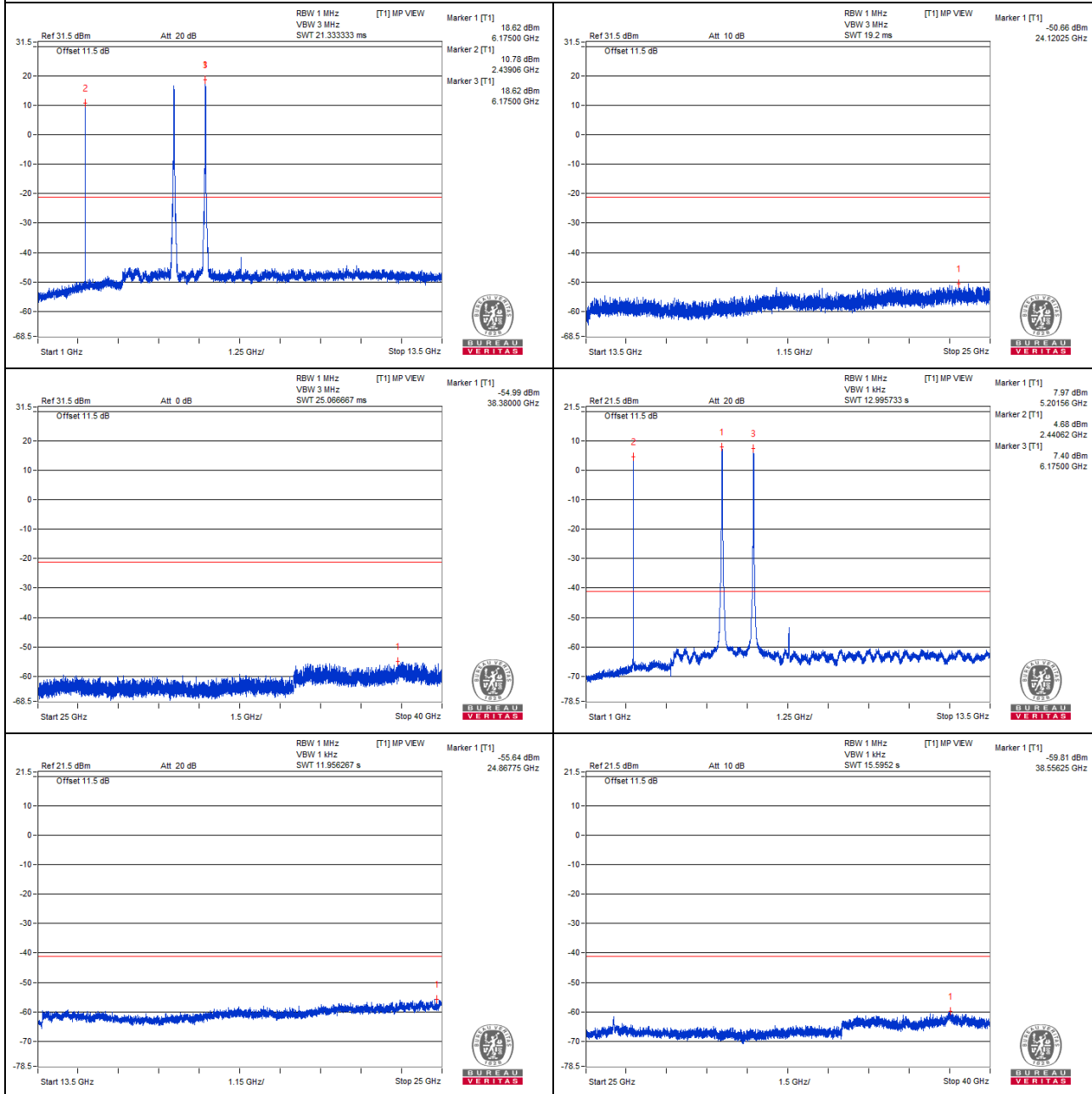

Below 1GHz Data:

Conducted spurious emission table

No.	Frequency (MHz)	Emission Level (dBuV/m)	Limit (dBuV/m)	Margin (dB)	Raw Value (dBm)		Correction Factor (dB)	EIRP Level (dBm)
					Chain0	Chain1		
1	78.86	36.95	40	-3.05	-69.42	-69.57	8.17	-58.31
2	128.21	36.83	43.5	-6.67	-70.45	-68.91	8.17	-58.43
3	222.06	36.79	46	-9.21	-70.17	-69.19	8.17	-58.47
4	537.55	37.59	46	-8.41	-70.04	-67.91	8.17	-57.67
5	748.28	38.55	46	-7.45	-68.01	-67.78	8.17	-56.71
6	920.09	38.67	46	-7.33	-67.17	-68.47	8.17	-56.59

Remarks:

1. Margin value = Emission Level – Limit value
2. The other emission levels were very low against the limit.

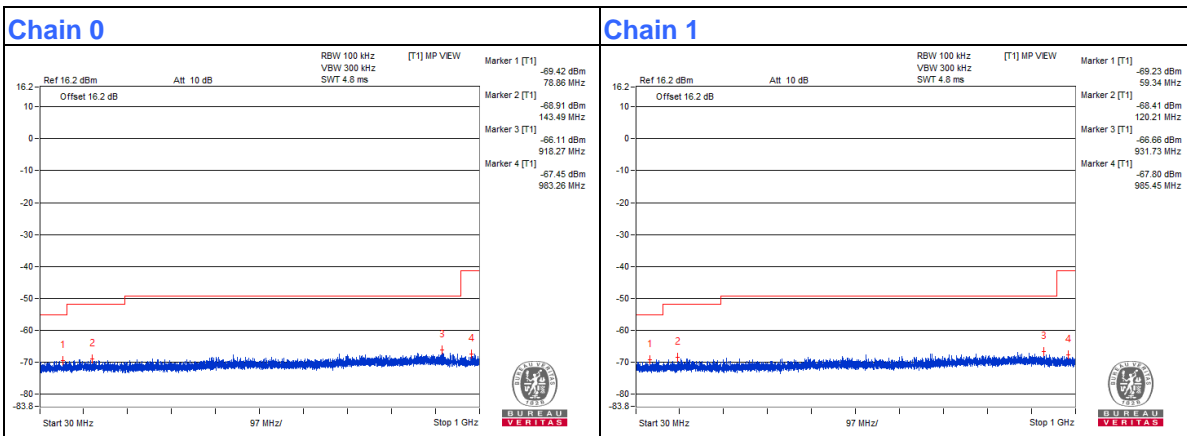

4.1.8 Test Results (Radiated Measurement)

Radiated test with 50ohm terminator on antenna port.

For Mode 1

Above 1GHz Data:

Frequency Range	1GHz ~ 40GHz	Detector Function	Peak (PK) Average (AV)
------------------------	--------------	--------------------------	---------------------------

Antenna Polarity & Test Distance : Horizontal at 3 m								
No	Frequency (MHz)	Emission Level (dBuV/m)	Limit (dBuV/m)	Margin (dB)	Antenna Height (m)	Table Angle (Degree)	Raw Value (dBuV)	Correction Factor (dB/m)
1	4824.00	46.5 PK	74.0	-27.5	2.48 H	348	45.2	1.3
2	4824.00	36.9 AV	54.0	-17.1	2.48 H	348	35.6	1.3
3	11160.00	45.9 PK	74.0	-28.1	1.02 H	212	33.9	12.0
4	11160.00	35.0 AV	54.0	-19.0	1.02 H	212	23.0	12.0
5	#16740.00	45.9 PK	68.2	-22.3	1.29 H	218	30.7	15.2
Antenna Polarity & Test Distance : Vertical at 3 m								
No	Frequency (MHz)	Emission Level (dBuV/m)	Limit (dBuV/m)	Margin (dB)	Antenna Height (m)	Table Angle (Degree)	Raw Value (dBuV)	Correction Factor (dB/m)
1	4824.00	42.7 PK	74.0	-31.3	3.89 V	285	41.4	1.3
2	4824.00	34.3 AV	54.0	-19.7	3.89 V	285	33.0	1.3
3	11160.00	42.6 PK	74.0	-31.4	3.91 V	275	30.6	12.0
4	11160.00	34.3 AV	54.0	-19.7	3.91 V	275	22.3	12.0
5	#16740.00	45.7 PK	68.2	-22.5	1.10 V	176	30.5	15.2

Remarks:

1. Emission Level(dBuV/m) = Raw Value(dBuV) + Correction Factor(dB/m)
2. Correction Factor(dB/m) = Antenna Factor(dB/m) + Cable Factor(dB) – Pre-Amplifier Factor(dB)
3. Margin value = Emission Level – Limit value
4. The other emission levels were very low against the limit.
5. " # ": The radiated frequency is out of the restricted band.

Below 1GHz Data:

Frequency Range	30MHz ~ 1GHz	Detector Function	Quasi-Peak (QP)
-----------------	--------------	-------------------	-----------------

Antenna Polarity & Test Distance : Horizontal at 3 m								
No	Frequency (MHz)	Emission Level (dBuV/m)	Limit (dBuV/m)	Margin (dB)	Antenna Height (m)	Table Angle (Degree)	Raw Value (dBuV)	Correction Factor (dB/m)
1	34.55	34.0 QP	40.0	-6.0	3.00 H	278	47.6	-13.6
2	107.87	37.5 QP	43.5	-6.0	2.00 H	328	53.5	-16.0
3	216.53	35.6 QP	46.0	-10.4	1.00 H	140	51.6	-16.0
4	296.69	41.8 QP	46.0	-4.2	1.00 H	182	54.2	-12.4
5	450.71	27.5 QP	46.0	-18.5	2.00 H	320	35.7	-8.2
6	497.99	38.0 QP	46.0	-8.0	1.50 H	179	45.6	-7.6

Remarks:

1. Emission Level(dBuV/m) = Raw Value(dBuV) + Correction Factor(dB/m)
2. Correction Factor(dB/m) = Antenna Factor(dB/m) + Cable Factor(dB) – Pre-Amplifier Factor(dB)
3. Margin value = Emission Level – Limit value
4. The other emission levels were very low against the limit of frequency range 30 MHz ~ 1 GHz.
5. The emission levels were very low against the limit of frequency range 9 kHz ~ 30 MHz: the amplitude of spurious emissions attenuated more than 20 dB below the permissible value to be report.

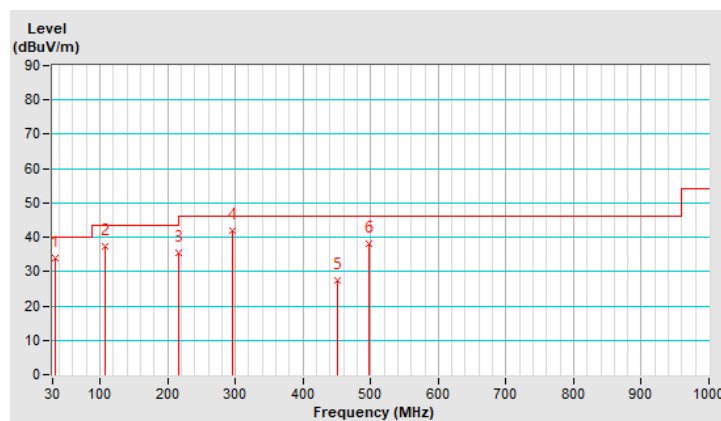

Frequency Range	30MHz ~ 1GHz	Detector Function	Quasi-Peak (QP)
-----------------	--------------	-------------------	-----------------

Antenna Polarity & Test Distance : Vertical at 3 m								
No	Frequency (MHz)	Emission Level (dBuV/m)	Limit (dBuV/m)	Margin (dB)	Antenna Height (m)	Table Angle (Degree)	Raw Value (dBuV)	Correction Factor (dB/m)
1	33.64	33.8 QP	40.0	-6.2	3.00 V	280	47.6	-13.8
2	104.22	38.3 QP	43.5	-5.2	2.00 V	303	55.0	-16.7
3	197.82	37.0 QP	43.5	-6.5	1.50 V	159	53.0	-16.0
4	296.44	39.6 QP	46.0	-6.4	1.00 V	202	52.0	-12.4
5	415.94	30.1 QP	46.0	-15.9	2.00 V	198	39.4	-9.3
6	498.83	39.6 QP	46.0	-6.4	1.50 V	318	47.2	-7.6

Remarks:

1. Emission Level(dBuV/m) = Raw Value(dBuV) + Correction Factor(dB/m)
2. Correction Factor(dB/m) = Antenna Factor(dB/m) + Cable Factor(dB) – Pre-Amplifier Factor(dB)
3. Margin value = Emission Level – Limit value
4. The other emission levels were very low against the limit of frequency range 30 MHz ~ 1 GHz.
5. The emission levels were very low against the limit of frequency range 9 kHz ~ 30 MHz: the amplitude of spurious emissions attenuated more than 20 dB below the permissible value to be report.

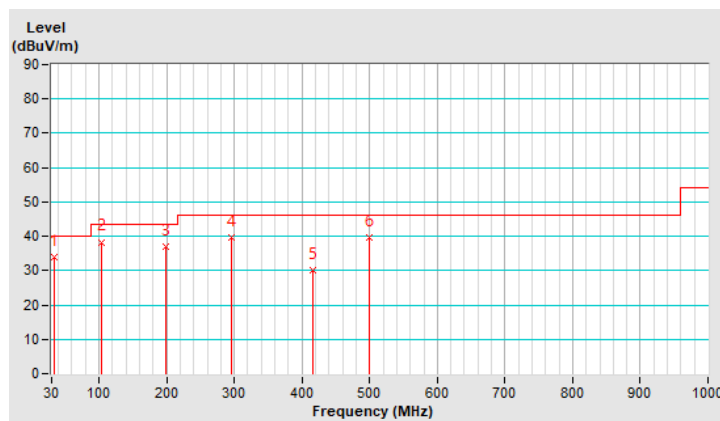

For Mode 2

Above 1GHz Data:

Frequency Range	1GHz ~ 40GHz	Detector Function	Peak (PK) Average (AV)
------------------------	--------------	--------------------------	---------------------------

Antenna Polarity & Test Distance : Horizontal at 3 m								
No	Frequency (MHz)	Emission Level (dBuV/m)	Limit (dBuV/m)	Margin (dB)	Antenna Height (m)	Table Angle (Degree)	Raw Value (dBuV)	Correction Factor (dB/m)
1	4824.00	46.7 PK	74.0	-27.3	2.42 H	354	45.2	1.5
2	4824.00	37.0 AV	54.0	-17.0	2.42 H	354	35.5	1.5
3	12350.00	48.4 PK	74.0	-25.6	1.10 H	186	37.0	11.4
4	12350.00	39.4 AV	54.0	-14.6	1.10 H	186	28.0	11.4
5	18525.00	46.6 PK	74.0	-27.4	1.25 H	206	53.2	-6.6
6	18525.00	36.4 AV	54.0	-17.6	1.25 H	206	43.0	-6.6

Antenna Polarity & Test Distance : Vertical at 3 m								
No	Frequency (MHz)	Emission Level (dBuV/m)	Limit (dBuV/m)	Margin (dB)	Antenna Height (m)	Table Angle (Degree)	Raw Value (dBuV)	Correction Factor (dB/m)
1	4824.00	43.5 PK	74.0	-30.5	3.85 V	288	42.0	1.5
2	4824.00	34.7 AV	54.0	-19.3	3.85 V	288	33.2	1.5
3	12350.00	43.0 PK	74.0	-31.0	1.16 V	144	31.6	11.4
4	12350.00	38.5 AV	54.0	-15.5	1.16 V	144	27.1	11.4
5	18525.00	46.9 PK	74.0	-27.1	1.01 V	174	53.5	-6.6
6	18525.00	36.3 AV	54.0	-17.7	1.01 V	174	42.9	-6.6

Remarks:

1. Emission Level(dBuV/m) = Raw Value(dBuV) + Correction Factor(dB/m)
2. Correction Factor(dB/m) = Antenna Factor(dB/m) + Cable Factor(dB) – Pre-Amplifier Factor(dB)
3. Margin value = Emission Level – Limit value
4. The other emission levels were very low against the limit.

Below 1GHz Data:

Frequency Range	30MHz ~ 1GHz	Detector Function	Quasi-Peak (QP)
------------------------	--------------	--------------------------	-----------------

Antenna Polarity & Test Distance : Horizontal at 3 m								
No	Frequency (MHz)	Emission Level (dBuV/m)	Limit (dBuV/m)	Margin (dB)	Antenna Height (m)	Table Angle (Degree)	Raw Value (dBuV)	Correction Factor (dB/m)
1	33.46	33.9 QP	40.0	-6.1	3.00 H	279	47.7	-13.8
2	106.55	38.1 QP	43.5	-5.4	2.00 H	326	54.4	-16.3
3	217.68	35.2 QP	46.0	-10.8	1.00 H	133	51.1	-15.9
4	297.41	41.6 QP	46.0	-4.4	1.00 H	171	53.9	-12.3
5	451.67	27.2 QP	46.0	-18.8	2.00 H	307	35.4	-8.2
6	498.94	38.0 QP	46.0	-8.0	1.50 H	189	45.6	-7.6

Remarks:

1. Emission Level(dBuV/m) = Raw Value(dBuV) + Correction Factor(dB/m)
2. Correction Factor(dB/m) = Antenna Factor(dB/m) + Cable Factor(dB) – Pre-Amplifier Factor(dB)
3. Margin value = Emission Level – Limit value
4. The other emission levels were very low against the limit of frequency range 30 MHz ~ 1 GHz.
5. The emission levels were very low against the limit of frequency range 9 kHz ~ 30 MHz: the amplitude of spurious emissions attenuated more than 20 dB below the permissible value to be report.

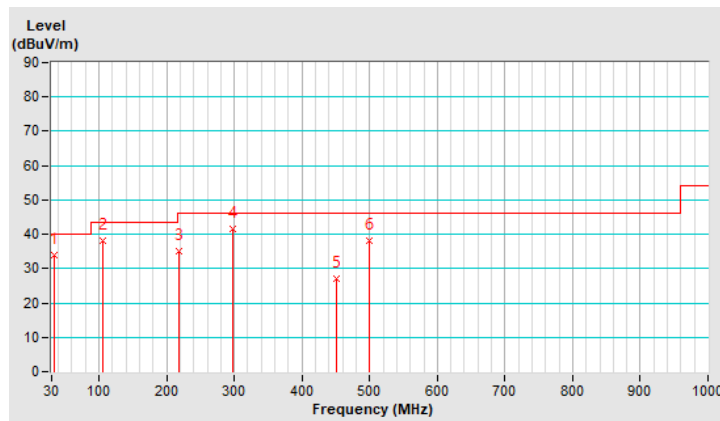

Frequency Range	30MHz ~ 1GHz	Detector Function	Quasi-Peak (QP)
-----------------	--------------	-------------------	-----------------

Antenna Polarity & Test Distance : Vertical at 3 m								
No	Frequency (MHz)	Emission Level (dBuV/m)	Limit (dBuV/m)	Margin (dB)	Antenna Height (m)	Table Angle (Degree)	Raw Value (dBuV)	Correction Factor (dB/m)
1	33.54	34.5 QP	40.0	-5.5	3.00 V	271	48.3	-13.8
2	104.93	38.3 QP	43.5	-5.2	2.00 V	309	54.7	-16.4
3	196.71	37.0 QP	43.5	-6.5	1.50 V	153	53.0	-16.0
4	296.74	39.4 QP	46.0	-6.6	1.00 V	214	51.8	-12.4
5	414.77	30.6 QP	46.0	-15.4	2.00 V	200	40.1	-9.5
6	499.16	40.0 QP	46.0	-6.0	1.50 V	305	47.6	-7.6

Remarks:

1. Emission Level(dBuV/m) = Raw Value(dBuV) + Correction Factor(dB/m)
2. Correction Factor(dB/m) = Antenna Factor(dB/m) + Cable Factor(dB) – Pre-Amplifier Factor(dB)
3. Margin value = Emission Level – Limit value
4. The other emission levels were very low against the limit of frequency range 30 MHz ~ 1 GHz.
5. The emission levels were very low against the limit of frequency range 9 kHz ~ 30 MHz: the amplitude of spurious emissions attenuated more than 20 dB below the permissible value to be report.

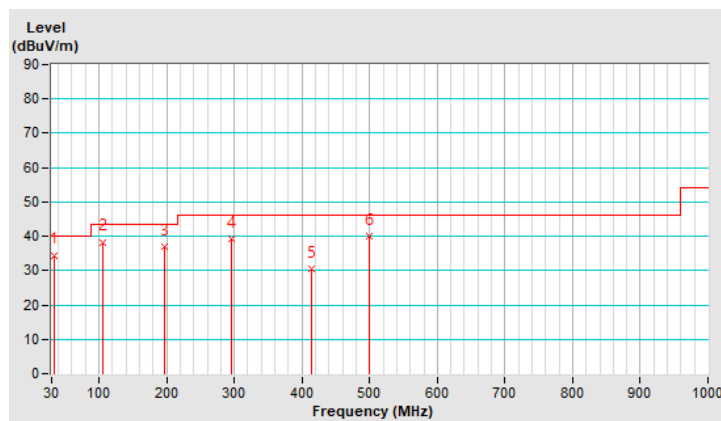

For Mode 3
Above 1GHz Data:

Frequency Range	1GHz ~ 40GHz	Detector Function	Peak (PK) Average (AV)
------------------------	--------------	--------------------------	---------------------------

Antenna Polarity & Test Distance : Horizontal at 3 m								
No	Frequency (MHz)	Emission Level (dBuV/m)	Limit (dBuV/m)	Margin (dB)	Antenna Height (m)	Table Angle (Degree)	Raw Value (dBuV)	Correction Factor (dB/m)
1	4880.00	46.5 PK	74.0	-27.5	2.52 H	355	45.2	1.3
2	4880.00	37.2 AV	54.0	-16.8	2.52 H	355	35.9	1.3
3	7320.00	47.1 PK	74.0	-26.9	2.50 H	360	40.1	7.0
4	7320.00	37.2 AV	54.0	-16.8	2.50 H	360	30.2	7.0
5	11160.00	46.2 PK	74.0	-27.8	1.08 H	202	34.2	12.0
6	11160.00	35.2 AV	54.0	-18.8	1.08 H	202	23.2	12.0
7	#16740.00	46.2 PK	68.2	-22.0	1.30 H	214	31.0	15.2

Antenna Polarity & Test Distance : Vertical at 3 m								
No	Frequency (MHz)	Emission Level (dBuV/m)	Limit (dBuV/m)	Margin (dB)	Antenna Height (m)	Table Angle (Degree)	Raw Value (dBuV)	Correction Factor (dB/m)
1	4880.00	43.3 PK	74.0	-30.7	3.88 V	286	42.0	1.3
2	4880.00	34.6 AV	54.0	-19.4	3.88 V	286	33.3	1.3
3	7320.00	43.6 PK	74.0	-30.4	3.85 V	293	36.6	7.0
4	7320.00	34.8 AV	54.0	-19.2	3.85 V	293	27.8	7.0
5	11160.00	42.3 PK	74.0	-31.7	3.94 V	265	30.3	12.0
6	11160.00	34.0 AV	54.0	-20.0	3.94 V	265	22.0	12.0
7	#16740.00	45.6 PK	68.2	-22.6	1.07 V	190	30.4	15.2

Remarks:

1. Emission Level(dBuV/m) = Raw Value(dBuV) + Correction Factor(dB/m)
2. Correction Factor(dB/m) = Antenna Factor(dB/m) + Cable Factor(dB) – Pre-Amplifier Factor(dB)
3. Margin value = Emission Level – Limit value
4. The other emission levels were very low against the limit.
5. " # ": The radiated frequency is out of the restricted band.

Below 1GHz Data:

Frequency Range	30MHz ~ 1GHz	Detector Function	Quasi-Peak (QP)
-----------------	--------------	-------------------	-----------------

Antenna Polarity & Test Distance : Horizontal at 3 m								
No	Frequency (MHz)	Emission Level (dBuV/m)	Limit (dBuV/m)	Margin (dB)	Antenna Height (m)	Table Angle (Degree)	Raw Value (dBuV)	Correction Factor (dB/m)
1	34.55	33.4 QP	40.0	-6.6	3.00 H	293	47.0	-13.6
2	106.88	37.9 QP	43.5	-5.6	2.00 H	339	54.1	-16.2
3	217.53	35.2 QP	46.0	-10.8	1.00 H	128	51.1	-15.9
4	297.02	42.2 QP	46.0	-3.8	1.00 H	176	54.6	-12.4
5	450.95	27.7 QP	46.0	-18.3	2.00 H	318	35.9	-8.2
6	496.86	37.5 QP	46.0	-8.5	1.50 H	183	45.1	-7.6

Remarks:

1. Emission Level(dBuV/m) = Raw Value(dBuV) + Correction Factor(dB/m)
2. Correction Factor(dB/m) = Antenna Factor(dB/m) + Cable Factor(dB) – Pre-Amplifier Factor(dB)
3. Margin value = Emission Level – Limit value
4. The other emission levels were very low against the limit of frequency range 30 MHz ~ 1 GHz.
5. The emission levels were very low against the limit of frequency range 9 kHz ~ 30 MHz: the amplitude of spurious emissions attenuated more than 20 dB below the permissible value to be report.

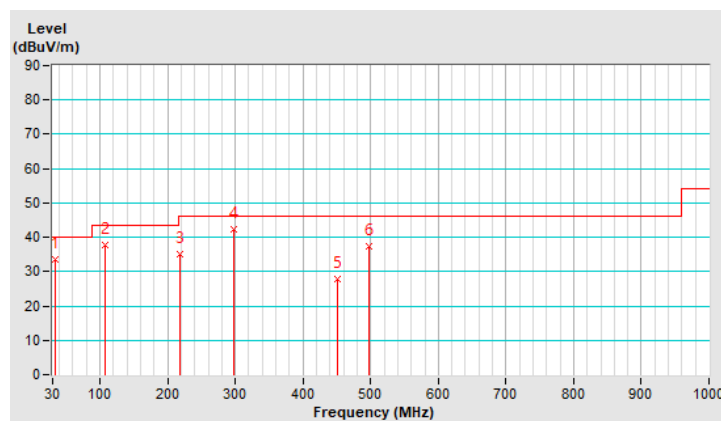

Frequency Range	30MHz ~ 1GHz	Detector Function	Quasi-Peak (QP)
-----------------	--------------	-------------------	-----------------

Antenna Polarity & Test Distance : Vertical at 3 m

No	Frequency (MHz)	Emission Level (dBuV/m)	Limit (dBuV/m)	Margin (dB)	Antenna Height (m)	Table Angle (Degree)	Raw Value (dBuV)	Correction Factor (dB/m)
1	34.72	33.8 QP	40.0	-6.2	3.00 V	289	47.4	-13.6
2	103.55	38.8 QP	43.5	-4.7	2.00 V	305	55.6	-16.8
3	197.67	36.8 QP	43.5	-6.7	1.50 V	146	52.8	-16.0
4	297.07	39.5 QP	46.0	-6.5	1.00 V	202	51.9	-12.4
5	414.91	29.9 QP	46.0	-16.1	2.00 V	186	39.4	-9.5
6	500.24	39.1 QP	46.0	-6.9	1.50 V	325	46.7	-7.6

Remarks:

1. Emission Level(dBuV/m) = Raw Value(dBuV) + Correction Factor(dB/m)
2. Correction Factor(dB/m) = Antenna Factor(dB/m) + Cable Factor(dB) – Pre-Amplifier Factor(dB)
3. Margin value = Emission Level – Limit value
4. The other emission levels were very low against the limit of frequency range 30 MHz ~ 1 GHz.
5. The emission levels were very low against the limit of frequency range 9 kHz ~ 30 MHz: the amplitude of spurious emissions attenuated more than 20 dB below the permissible value to be report.

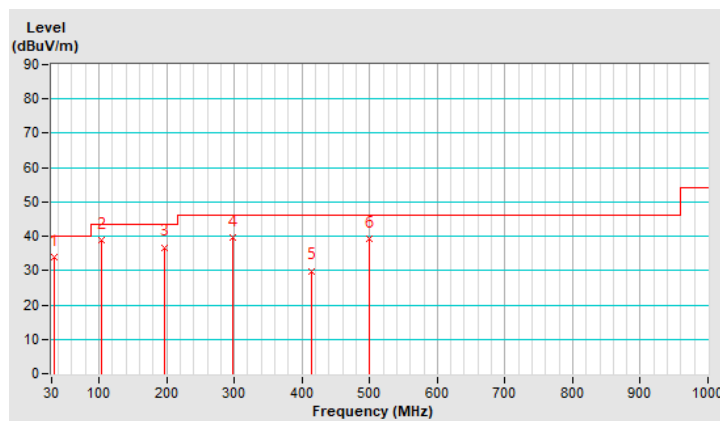

For Mode 4

Above 1GHz Data:

Frequency Range	1GHz ~ 40GHz	Detector Function	Peak (PK) Average (AV)
------------------------	--------------	--------------------------	---------------------------

Antenna Polarity & Test Distance : Horizontal at 3 m								
No	Frequency (MHz)	Emission Level (dBuV/m)	Limit (dBuV/m)	Margin (dB)	Antenna Height (m)	Table Angle (Degree)	Raw Value (dBuV)	Correction Factor (dB/m)
1	4880.00	46.1 PK	74.0	-27.9	2.49 H	342	44.6	1.5
2	4880.00	36.6 AV	54.0	-17.4	2.49 H	342	35.1	1.5
3	7320.00	46.4 PK	74.0	-27.6	2.45 H	345	39.2	7.2
4	7320.00	36.8 AV	54.0	-17.2	2.45 H	345	29.6	7.2
5	12350.00	48.0 PK	74.0	-26.0	1.15 H	178	36.6	11.4
6	12350.00	39.1 AV	54.0	-14.9	1.15 H	178	27.7	11.4
7	18525.00	46.6 PK	74.0	-27.4	1.24 H	194	53.2	-6.6
8	18525.00	36.4 AV	54.0	-17.6	1.24 H	194	43.0	-6.6

Antenna Polarity & Test Distance : Vertical at 3 m								
No	Frequency (MHz)	Emission Level (dBuV/m)	Limit (dBuV/m)	Margin (dB)	Antenna Height (m)	Table Angle (Degree)	Raw Value (dBuV)	Correction Factor (dB/m)
1	4880.00	43.6 PK	74.0	-30.4	3.81 V	305	42.1	1.5
2	4880.00	34.9 AV	54.0	-19.1	3.81 V	305	33.4	1.5
3	7320.00	42.5 PK	74.0	-31.5	3.81 V	280	35.3	7.2
4	7320.00	34.1 AV	54.0	-19.9	3.81 V	280	26.9	7.2
5	12350.00	43.2 PK	74.0	-30.8	1.15 V	135	31.8	11.4
6	12350.00	38.6 AV	54.0	-15.4	1.15 V	135	27.2	11.4
7	18525.00	47.3 PK	74.0	-26.7	1.00 V	175	53.9	-6.6
8	18525.00	36.5 AV	54.0	-17.5	1.00 V	175	43.1	-6.6

Remarks:

1. Emission Level(dBuV/m) = Raw Value(dBuV) + Correction Factor(dB/m)
2. Correction Factor(dB/m) = Antenna Factor(dB/m) + Cable Factor(dB) – Pre-Amplifier Factor(dB)
3. Margin value = Emission Level – Limit value
4. The other emission levels were very low against the limit.

Below 1GHz Data:

Frequency Range	30MHz ~ 1GHz	Detector Function	Quasi-Peak (QP)
-----------------	--------------	-------------------	-----------------

Antenna Polarity & Test Distance : Horizontal at 3 m								
No	Frequency (MHz)	Emission Level (dBuV/m)	Limit (dBuV/m)	Margin (dB)	Antenna Height (m)	Table Angle (Degree)	Raw Value (dBuV)	Correction Factor (dB/m)
1	34.71	34.3 QP	40.0	-5.7	3.00 H	281	47.9	-13.6
2	106.51	37.4 QP	43.5	-6.1	2.00 H	326	53.7	-16.3
3	217.12	35.8 QP	46.0	-10.2	1.00 H	150	51.7	-15.9
4	295.67	41.8 QP	46.0	-4.2	1.00 H	192	54.2	-12.4
5	450.75	27.5 QP	46.0	-18.5	2.00 H	320	35.7	-8.2
6	498.26	37.9 QP	46.0	-8.1	1.50 H	181	45.5	-7.6

Remarks:

1. Emission Level(dBuV/m) = Raw Value(dBuV) + Correction Factor(dB/m)
2. Correction Factor(dB/m) = Antenna Factor(dB/m) + Cable Factor(dB) – Pre-Amplifier Factor(dB)
3. Margin value = Emission Level – Limit value
4. The other emission levels were very low against the limit of frequency range 30 MHz ~ 1 GHz.
5. The emission levels were very low against the limit of frequency range 9 kHz ~ 30 MHz: the amplitude of spurious emissions attenuated more than 20 dB below the permissible value to be report.

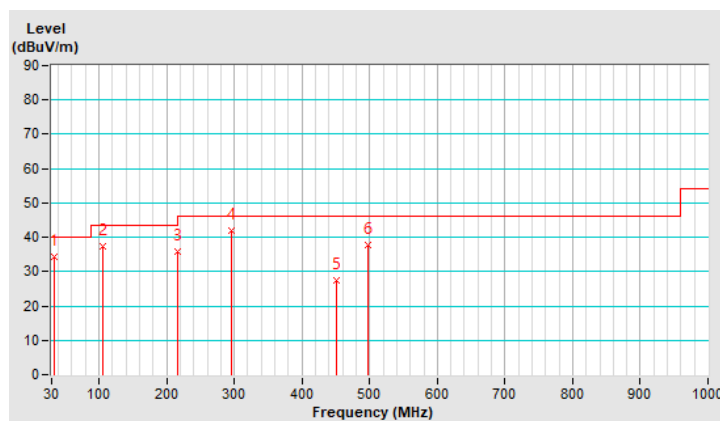

Frequency Range	30MHz ~ 1GHz	Detector Function	Quasi-Peak (QP)
------------------------	--------------	--------------------------	-----------------

Antenna Polarity & Test Distance : Vertical at 3 m

No	Frequency (MHz)	Emission Level (dBuV/m)	Limit (dBuV/m)	Margin (dB)	Antenna Height (m)	Table Angle (Degree)	Raw Value (dBuV)	Correction Factor (dB/m)
1	32.22	34.2 QP	40.0	-5.8	3.00 V	265	48.0	-13.8
2	103.66	38.0 QP	43.5	-5.5	2.00 V	291	54.8	-16.8
3	199.09	37.0 QP	43.5	-6.5	1.50 V	168	53.1	-16.1
4	296.19	39.5 QP	46.0	-6.5	1.00 V	201	51.9	-12.4
5	414.68	30.1 QP	46.0	-15.9	2.00 V	191	39.6	-9.5
6	499.62	39.8 QP	46.0	-6.2	1.50 V	315	47.4	-7.6

Remarks:

1. Emission Level(dBuV/m) = Raw Value(dBuV) + Correction Factor(dB/m)
2. Correction Factor(dB/m) = Antenna Factor(dB/m) + Cable Factor(dB) – Pre-Amplifier Factor(dB)
3. Margin value = Emission Level – Limit value
4. The other emission levels were very low against the limit of frequency range 30 MHz ~ 1 GHz.
5. The emission levels were very low against the limit of frequency range 9 kHz ~ 30 MHz: the amplitude of spurious emissions attenuated more than 20 dB below the permissible value to be report.

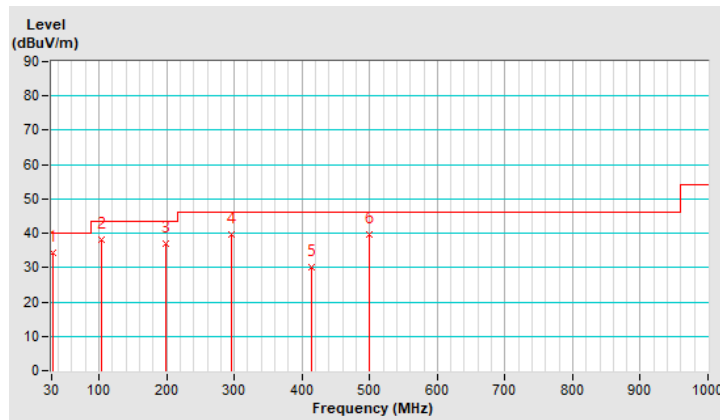

For Mode 5

Above 1GHz Data:

Frequency Range	1GHz ~ 40GHz	Detector Function	Peak (PK) Average (AV)
------------------------	--------------	--------------------------	---------------------------

Antenna Polarity & Test Distance : Horizontal at 3 m								
No	Frequency (MHz)	Emission Level (dBuV/m)	Limit (dBuV/m)	Margin (dB)	Antenna Height (m)	Table Angle (Degree)	Raw Value (dBuV)	Correction Factor (dB/m)
1	4880.00	47.4 PK	74.0	-26.6	2.45 H	327	46.1	1.3
2	4880.00	37.3 AV	54.0	-16.7	2.45 H	327	36.0	1.3
3	7320.00	47.1 PK	74.0	-26.9	2.49 H	348	40.1	7.0
4	7320.00	37.5 AV	54.0	-16.5	2.49 H	348	30.5	7.0
5	#10400.00	45.8 PK	68.2	-22.4	1.00 H	200	34.0	11.8
6	11160.00	45.6 PK	74.0	-28.4	1.09 H	221	33.6	12.0
7	11160.00	34.6 AV	54.0	-19.4	1.09 H	221	22.6	12.0
8	15600.00	46.0 PK	74.0	-28.0	1.30 H	207	34.3	11.7
9	15600.00	34.4 AV	54.0	-19.6	1.30 H	207	22.7	11.7
10	#16740.00	46.5 PK	68.2	-21.7	1.23 H	216	31.3	15.2

Antenna Polarity & Test Distance : Vertical at 3 m								
No	Frequency (MHz)	Emission Level (dBuV/m)	Limit (dBuV/m)	Margin (dB)	Antenna Height (m)	Table Angle (Degree)	Raw Value (dBuV)	Correction Factor (dB/m)
1	4880.00	42.7 PK	74.0	-31.3	3.80 V	299	41.4	1.3
2	4880.00	34.3 AV	54.0	-19.7	3.80 V	299	33.0	1.3
3	7320.00	42.9 PK	74.0	-31.1	3.87 V	296	35.9	7.0
4	7320.00	34.1 AV	54.0	-19.9	3.87 V	296	27.1	7.0
5	#10400.00	42.5 PK	68.2	-25.7	3.96 V	287	30.7	11.8
6	11160.00	42.6 PK	74.0	-31.4	3.87 V	260	30.6	12.0
7	11160.00	34.3 AV	54.0	-19.7	3.87 V	260	22.3	12.0
8	15600.00	45.2 PK	74.0	-28.8	1.12 V	174	33.5	11.7
9	15600.00	33.8 AV	54.0	-20.2	1.12 V	174	22.1	11.7
10	#16740.00	45.3 PK	68.2	-22.9	1.08 V	166	30.1	15.2

Remarks:

1. Emission Level(dBuV/m) = Raw Value(dBuV) + Correction Factor(dB/m)
2. Correction Factor(dB/m) = Antenna Factor(dB/m) + Cable Factor(dB) – Pre-Amplifier Factor(dB)
3. Margin value = Emission Level – Limit value
4. The other emission levels were very low against the limit.
5. " # ": The radiated frequency is out of the restricted band.

Below 1GHz Data:

Frequency Range	30MHz ~ 1GHz	Detector Function	Quasi-Peak (QP)
------------------------	--------------	--------------------------	-----------------

Antenna Polarity & Test Distance : Horizontal at 3 m								
No	Frequency (MHz)	Emission Level (dBuV/m)	Limit (dBuV/m)	Margin (dB)	Antenna Height (m)	Table Angle (Degree)	Raw Value (dBuV)	Correction Factor (dB/m)
1	33.57	34.5 QP	40.0	-5.5	3.00 H	277	48.3	-13.8
2	106.95	37.5 QP	43.5	-6.0	2.00 H	340	53.7	-16.2
3	217.18	36.2 QP	46.0	-9.8	1.00 H	140	52.1	-15.9
4	295.49	41.3 QP	46.0	-4.7	1.00 H	178	53.7	-12.4
5	451.03	27.4 QP	46.0	-18.6	2.00 H	332	35.6	-8.2
6	499.31	38.0 QP	46.0	-8.0	1.50 H	192	45.6	-7.6

Remarks:

1. Emission Level(dBuV/m) = Raw Value(dBuV) + Correction Factor(dB/m)
2. Correction Factor(dB/m) = Antenna Factor(dB/m) + Cable Factor(dB) – Pre-Amplifier Factor(dB)
3. Margin value = Emission Level – Limit value
4. The other emission levels were very low against the limit of frequency range 30 MHz ~ 1 GHz.
5. The emission levels were very low against the limit of frequency range 9 kHz ~ 30 MHz: the amplitude of spurious emissions attenuated more than 20 dB below the permissible value to be report.

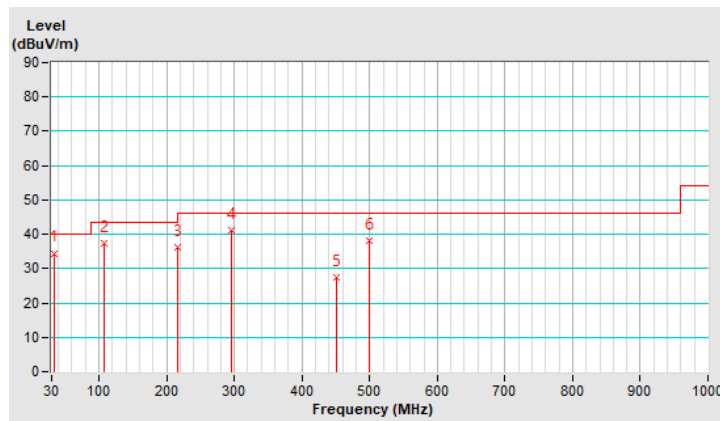

Frequency Range	30MHz ~ 1GHz	Detector Function	Quasi-Peak (QP)
-----------------	--------------	-------------------	-----------------

Antenna Polarity & Test Distance : Vertical at 3 m

No	Frequency (MHz)	Emission Level (dBuV/m)	Limit (dBuV/m)	Margin (dB)	Antenna Height (m)	Table Angle (Degree)	Raw Value (dBuV)	Correction Factor (dB/m)
1	33.91	34.0 QP	40.0	-6.0	3.00 V	278	47.8	-13.8
2	103.67	38.5 QP	43.5	-5.0	2.00 V	294	55.3	-16.8
3	196.89	37.1 QP	43.5	-6.4	1.50 V	172	53.1	-16.0
4	296.73	39.4 QP	46.0	-6.6	1.00 V	209	51.8	-12.4
5	415.21	29.8 QP	46.0	-16.2	2.00 V	189	39.2	-9.4
6	497.43	39.0 QP	46.0	-7.0	1.50 V	307	46.6	-7.6

Remarks:

1. Emission Level(dBuV/m) = Raw Value(dBuV) + Correction Factor(dB/m)
2. Correction Factor(dB/m) = Antenna Factor(dB/m) + Cable Factor(dB) – Pre-Amplifier Factor(dB)
3. Margin value = Emission Level – Limit value
4. The other emission levels were very low against the limit of frequency range 30 MHz ~ 1 GHz.
5. The emission levels were very low against the limit of frequency range 9 kHz ~ 30 MHz: the amplitude of spurious emissions attenuated more than 20 dB below the permissible value to be report.

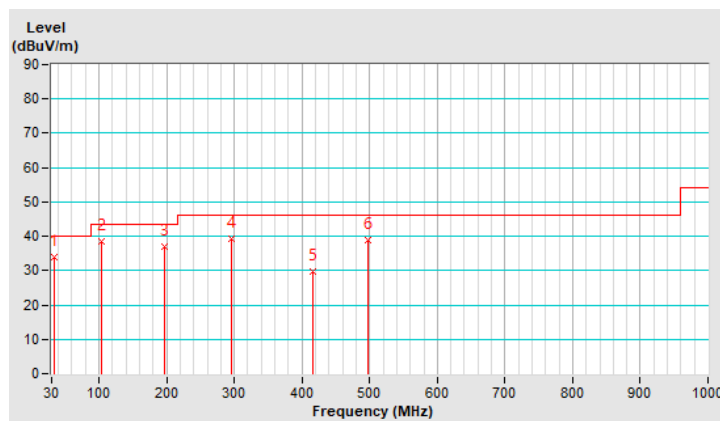

For Mode 6

Above 1GHz Data:

Frequency Range	1GHz ~ 40GHz	Detector Function	Peak (PK) Average (AV)
------------------------	--------------	--------------------------	---------------------------

Antenna Polarity & Test Distance : Horizontal at 3 m								
No	Frequency (MHz)	Emission Level (dBuV/m)	Limit (dBuV/m)	Margin (dB)	Antenna Height (m)	Table Angle (Degree)	Raw Value (dBuV)	Correction Factor (dB/m)
1	4880.00	47.2 PK	74.0	-26.8	2.50 H	336	45.7	1.5
2	4880.00	37.4 AV	54.0	-16.6	2.50 H	336	35.9	1.5
3	7320.00	46.9 PK	74.0	-27.1	2.48 H	334	39.7	7.2
4	7320.00	37.2 AV	54.0	-16.8	2.48 H	334	30.0	7.2
5	12350.00	48.6 PK	74.0	-25.4	1.11 H	179	37.2	11.4
6	12350.00	39.8 AV	54.0	-14.2	1.11 H	179	28.4	11.4
7	18525.00	46.5 PK	74.0	-27.5	1.31 H	205	53.1	-6.6
8	18525.00	36.1 AV	54.0	-17.9	1.31 H	205	42.7	-6.6

Antenna Polarity & Test Distance : Vertical at 3 m								
No	Frequency (MHz)	Emission Level (dBuV/m)	Limit (dBuV/m)	Margin (dB)	Antenna Height (m)	Table Angle (Degree)	Raw Value (dBuV)	Correction Factor (dB/m)
1	4880.00	43.1 PK	74.0	-30.9	3.84 V	290	41.6	1.5
2	4880.00	34.5 AV	54.0	-19.5	3.84 V	290	33.0	1.5
3	7320.00	43.1 PK	74.0	-30.9	3.82 V	281	35.9	7.2
4	7320.00	34.6 AV	54.0	-19.4	3.82 V	281	27.4	7.2
5	12350.00	43.3 PK	74.0	-30.7	1.14 V	143	31.9	11.4
6	12350.00	38.8 AV	54.0	-15.2	1.14 V	143	27.4	11.4
7	18525.00	47.6 PK	74.0	-26.4	1.07 V	186	54.2	-6.6
8	18525.00	36.8 AV	54.0	-17.2	1.07 V	186	43.4	-6.6

Remarks:

1. Emission Level(dBuV/m) = Raw Value(dBuV) + Correction Factor(dB/m)
2. Correction Factor(dB/m) = Antenna Factor(dB/m) + Cable Factor(dB) – Pre-Amplifier Factor(dB)
3. Margin value = Emission Level – Limit value
4. The other emission levels were very low against the limit.

Below 1GHz Data:

Frequency Range	30MHz ~ 1GHz	Detector Function	Quasi-Peak (QP)
------------------------	--------------	--------------------------	-----------------

Antenna Polarity & Test Distance : Horizontal at 3 m								
No	Frequency (MHz)	Emission Level (dBuV/m)	Limit (dBuV/m)	Margin (dB)	Antenna Height (m)	Table Angle (Degree)	Raw Value (dBuV)	Correction Factor (dB/m)
1	35.77	34.1 QP	40.0	-5.9	3.00 H	268	47.7	-13.6
2	108.63	36.9 QP	43.5	-6.6	2.00 H	331	52.9	-16.0
3	216.75	35.1 QP	46.0	-10.9	1.00 H	144	51.1	-16.0
4	296.34	41.4 QP	46.0	-4.6	1.00 H	178	53.8	-12.4
5	451.00	27.2 QP	46.0	-18.8	2.00 H	323	35.4	-8.2
6	499.46	38.3 QP	46.0	-7.7	1.50 H	195	45.9	-7.6

Remarks:

1. Emission Level(dBuV/m) = Raw Value(dBuV) + Correction Factor(dB/m)
2. Correction Factor(dB/m) = Antenna Factor(dB/m) + Cable Factor(dB) – Pre-Amplifier Factor(dB)
3. Margin value = Emission Level – Limit value
4. The other emission levels were very low against the limit of frequency range 30 MHz ~ 1 GHz.
5. The emission levels were very low against the limit of frequency range 9 kHz ~ 30 MHz: the amplitude of spurious emissions attenuated more than 20 dB below the permissible value to be report.

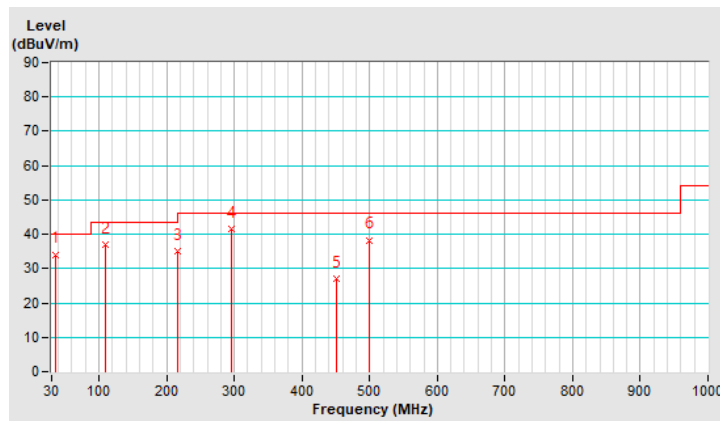

Frequency Range	30MHz ~ 1GHz	Detector Function	Quasi-Peak (QP)
------------------------	--------------	--------------------------	-----------------

Antenna Polarity & Test Distance : Vertical at 3 m								
No	Frequency (MHz)	Emission Level (dBuV/m)	Limit (dBuV/m)	Margin (dB)	Antenna Height (m)	Table Angle (Degree)	Raw Value (dBuV)	Correction Factor (dB/m)
1	34.95	34.1 QP	40.0	-5.9	3.00 V	286	47.6	-13.5
2	104.02	38.2 QP	43.5	-5.3	2.00 V	290	54.9	-16.7
3	196.87	36.9 QP	43.5	-6.6	1.50 V	164	52.9	-16.0
4	297.22	39.6 QP	46.0	-6.4	1.00 V	205	52.0	-12.4
5	417.02	29.6 QP	46.0	-16.4	2.00 V	196	38.9	-9.3
6	498.58	39.6 QP	46.0	-6.4	1.50 V	308	47.2	-7.6

Remarks:

1. Emission Level(dBuV/m) = Raw Value(dBuV) + Correction Factor(dB/m)
2. Correction Factor(dB/m) = Antenna Factor(dB/m) + Cable Factor(dB) – Pre-Amplifier Factor(dB)
3. Margin value = Emission Level – Limit value
4. The other emission levels were very low against the limit of frequency range 30 MHz ~ 1 GHz.
5. The emission levels were very low against the limit of frequency range 9 kHz ~ 30 MHz: the amplitude of spurious emissions attenuated more than 20 dB below the permissible value to be report.

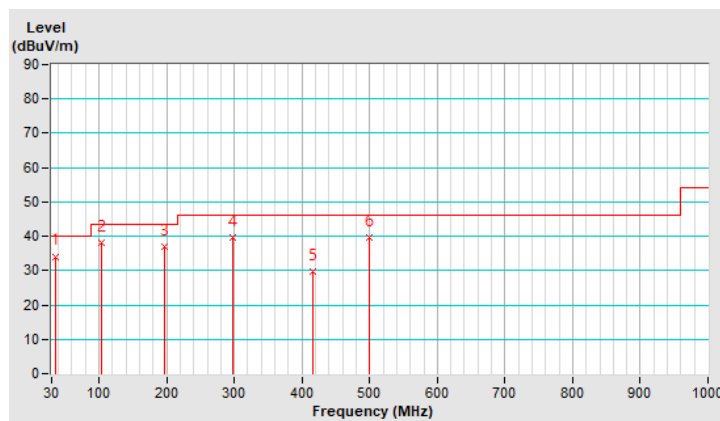



4.2 Conducted Emission Measurement

4.2.1 Limits of Conducted Emission Measurement

Frequency (MHz)	Conducted Limit (dBuV)	
	Quasi-peak	Average
0.15 - 0.5	66 - 56	56 - 46
0.50 - 5.0	56	46
5.0 - 30.0	60	50

Note: 1. The lower limit shall apply at the transition frequencies.

2. The limit decreases in line with the logarithm of the frequency in the range of 0.15 to 0.50MHz.

4.2.2 Test Instruments

Description & Manufacturer	Model No.	Serial No.	Calibrated Date	Calibrated Until
TEST RECEIVER R&S	ESCS 30	847124/029	2022/10/14	2023/10/13
LISN R&S	ESH3-Z5	848773/004	2022/10/18	2023/10/17
50 ohm terminal resistance NA	NA	EMC-01	2022/9/27	2023/9/26
RF Coaxial Cable JYEBO	5D-FB	COCCAB-001	2022/8/24	2023/8/23
Fixed attenuator STI	STI02-2200-10	005	2022/8/24	2023/8/23
Software BVADT	BVADT_Cond_V7.3.7.4	NA	NA	NA

Note: 1. The test was performed in Conduction 1.

2. The calibration interval of the above test instruments is 12 months and the calibrations are traceable to NML/ROC and NIST/USA.

3. Tested Date: 2023/2/20

4.2.3 Test Procedures

- The EUT was placed 0.4 meters from the conducting wall of the shielded room with EUT being connected to the power mains through a line impedance stabilization network (LISN). Other support units were connected to the power mains through another LISN. The two LISNs provide 50 ohm/ 50uH of coupling impedance for the measuring instrument.
- Both lines of the power mains connected to the EUT were checked for maximum conducted interference.
- The frequency range from 150kHz to 30MHz was searched. Emission levels under (Limit - 20dB) was not recorded.

Note: The resolution bandwidth and video bandwidth of test receiver is 9kHz for quasi-peak detection (QP) and average detection (AV) at frequency 0.15MHz-30MHz.

4.2.4 Deviation from Test Standard

No deviation.

4.2.5 Test Setup

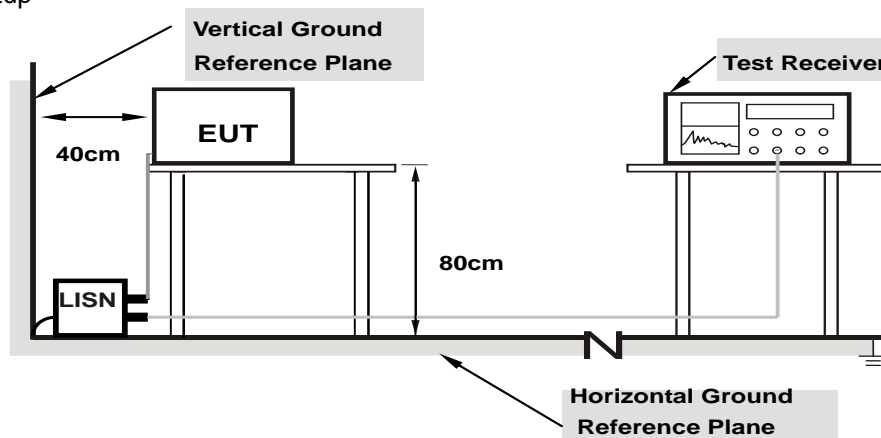

Note: 1.Support units were connected to second LISN.

For the actual test configuration, please refer to the attached file (Test Setup Photo).

4.2.6 EUT Operating Conditions

Same as 4.1.6.

4.2.7 Test Results (Mode 1)

Frequency Range	150kHz ~ 30MHz	Detector Function & Resolution Bandwidth	Quasi-Peak (QP) / Average (AV), 9kHz
------------------------	----------------	---	--------------------------------------

Phase Of Power : Line (L)										
No	Frequency (MHz)	Correction Factor (dB)	Reading Value (dBuV)		Emission Level (dBuV)		Limit (dBuV)		Margin (dB)	
			Q.P.	AV.	Q.P.	AV.	Q.P.	AV.	Q.P.	AV.
1	0.15393	9.96	31.88	24.71	41.84	34.67	65.79	55.79	-23.95	-21.12
2	0.56790	9.98	32.07	26.66	42.05	36.64	56.00	46.00	-13.95	-9.36
3	0.89605	9.99	19.76	16.19	29.75	26.18	56.00	46.00	-26.25	-19.82
4	1.62899	10.03	22.31	18.23	32.34	28.26	56.00	46.00	-23.66	-17.74
5	14.52736	10.77	27.44	20.79	38.21	31.56	60.00	50.00	-21.79	-18.44
6	26.62102	11.21	33.32	28.47	44.53	39.68	60.00	50.00	-15.47	-10.32

Remarks:

1. Q.P. and AV. are abbreviations of quasi-peak and average individually.
2. The emission levels of other frequencies were very low against the limit.
3. Margin value = Emission level – Limit value
4. Correction factor = Insertion loss + Cable loss
5. Emission Level = Correction Factor + Reading Value

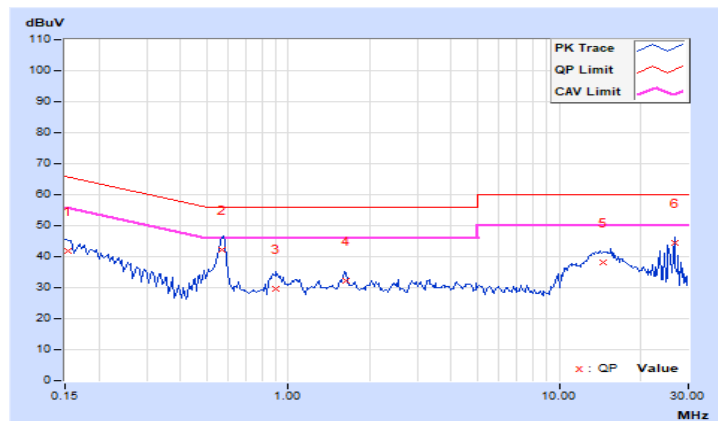

Frequency Range	150kHz ~ 30MHz	Detector Function & Resolution Bandwidth	Quasi-Peak (QP) / Average (AV), 9kHz
------------------------	----------------	---	--------------------------------------

Phase Of Power : Neutral (N)										
No	Frequency (MHz)	Correction Factor (dB)	Reading Value (dBuV)		Emission Level (dBuV)		Limit (dBuV)		Margin (dB)	
			Q.P.	AV.	Q.P.	AV.	Q.P.	AV.	Q.P.	AV.
1	0.15398	9.93	32.57	19.37	42.50	29.30	65.78	55.78	-23.28	-26.48
2	0.23206	9.94	24.33	10.62	34.27	20.56	62.38	52.38	-28.11	-31.82
3	0.57963	9.95	27.91	18.71	37.86	28.66	56.00	46.00	-18.14	-17.34
4	0.88041	9.96	14.42	2.36	24.38	12.32	56.00	46.00	-31.62	-33.68
5	14.17962	10.57	20.73	13.45	31.30	24.02	60.00	50.00	-28.70	-25.98
6	25.85938	10.86	24.46	18.37	35.32	29.23	60.00	50.00	-24.68	-20.77

Remarks:

1. Q.P. and AV. are abbreviations of quasi-peak and average individually.
2. The emission levels of other frequencies were very low against the limit.
3. Margin value = Emission level – Limit value
4. Correction factor = Insertion loss + Cable loss
5. Emission Level = Correction Factor + Reading Value

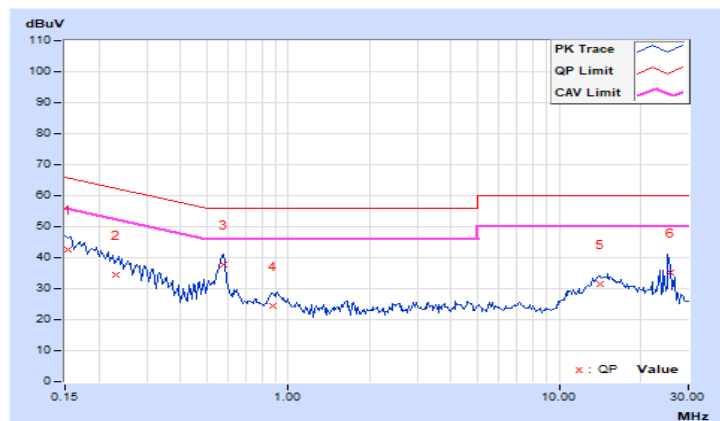

4.2.8 Test Results (Mode 2)

Frequency Range	150kHz ~ 30MHz	Detector Function & Resolution Bandwidth	Quasi-Peak (QP) / Average (AV), 9kHz
------------------------	----------------	---	--------------------------------------

Phase Of Power : Line (L)										
No	Frequency (MHz)	Correction Factor (dB)	Reading Value (dBuV)		Emission Level (dBuV)		Limit (dBuV)		Margin (dB)	
			Q.P.	AV.	Q.P.	AV.	Q.P.	AV.	Q.P.	AV.
1	0.15398	9.96	31.31	24.45	41.27	34.41	65.78	55.78	-24.51	-21.37
2	0.56794	9.98	32.25	26.57	42.23	36.55	56.00	46.00	-13.77	-9.45
3	0.89609	9.99	19.69	16.28	29.68	26.27	56.00	46.00	-26.32	-19.73
4	1.62892	10.03	22.88	18.96	32.91	28.99	56.00	46.00	-23.09	-17.01
5	14.52737	10.77	27.43	20.34	38.20	31.11	60.00	50.00	-21.80	-18.89
6	26.62103	11.21	33.41	28.50	44.62	39.71	60.00	50.00	-15.38	-10.29

Remarks:

1. Q.P. and AV. are abbreviations of quasi-peak and average individually.
2. The emission levels of other frequencies were very low against the limit.
3. Margin value = Emission level – Limit value
4. Correction factor = Insertion loss + Cable loss
5. Emission Level = Correction Factor + Reading Value

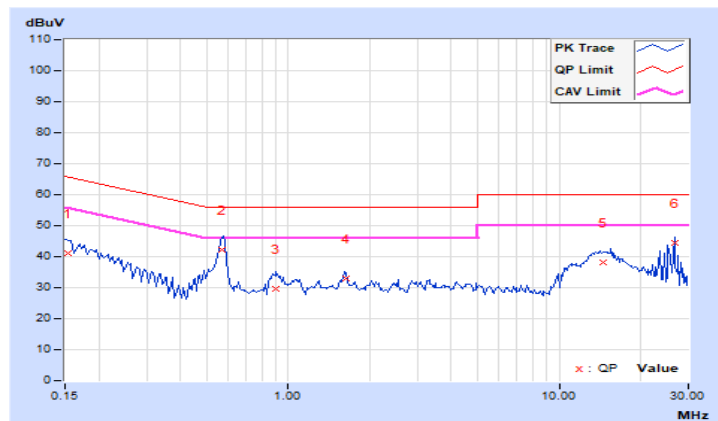

Frequency Range	150kHz ~ 30MHz	Detector Function & Resolution Bandwidth	Quasi-Peak (QP) / Average (AV), 9kHz
------------------------	----------------	---	--------------------------------------

Phase Of Power : Neutral (N)										
No	Frequency (MHz)	Correction Factor (dB)	Reading Value (dBuV)		Emission Level (dBuV)		Limit (dBuV)		Margin (dB)	
			Q.P.	AV.	Q.P.	AV.	Q.P.	AV.	Q.P.	AV.
1	0.15394	9.93	32.69	19.47	42.62	29.40	65.78	55.78	-23.16	-26.38
2	0.23202	9.94	24.38	10.38	34.32	20.32	62.38	52.38	-28.06	-32.06
3	0.57961	9.95	27.87	18.81	37.82	28.76	56.00	46.00	-18.18	-17.24
4	0.88040	9.96	14.56	2.57	24.52	12.53	56.00	46.00	-31.48	-33.47
5	14.17968	10.57	20.76	13.41	31.33	23.98	60.00	50.00	-28.67	-26.02
6	25.85933	10.86	24.38	18.30	35.24	29.16	60.00	50.00	-24.76	-20.84

Remarks:

1. Q.P. and AV. are abbreviations of quasi-peak and average individually.
2. The emission levels of other frequencies were very low against the limit.
3. Margin value = Emission level – Limit value
4. Correction factor = Insertion loss + Cable loss
5. Emission Level = Correction Factor + Reading Value

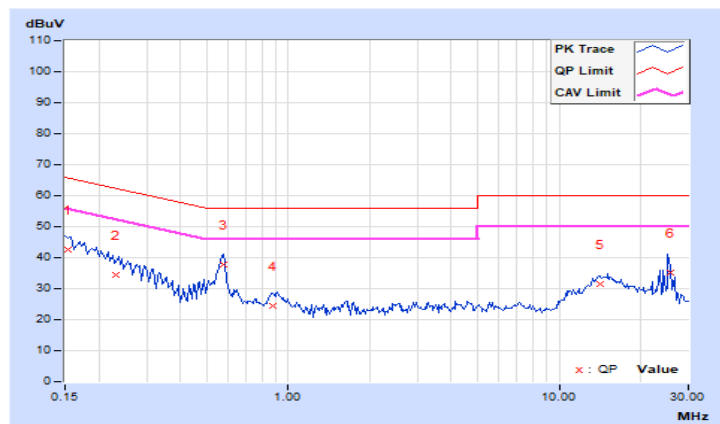

4.2.9 Test Results (Mode 3)

Frequency Range	150kHz ~ 30MHz	Detector Function & Resolution Bandwidth	Quasi-Peak (QP) / Average (AV), 9kHz
------------------------	----------------	---	--------------------------------------

Phase Of Power : Line (L)										
No	Frequency (MHz)	Correction Factor (dB)	Reading Value (dBuV)		Emission Level (dBuV)		Limit (dBuV)		Margin (dB)	
			Q.P.	AV.	Q.P.	AV.	Q.P.	AV.	Q.P.	AV.
1	0.15392	9.96	31.24	24.45	41.20	34.41	65.79	55.79	-24.59	-21.38
2	0.56790	9.98	32.76	26.57	42.74	36.55	56.00	46.00	-13.26	-9.45
3	0.89601	9.99	19.51	16.37	29.50	26.36	56.00	46.00	-26.50	-19.64
4	1.62897	10.03	22.88	18.64	32.91	28.67	56.00	46.00	-23.09	-17.33
5	14.52735	10.77	27.43	20.58	38.20	31.35	60.00	50.00	-21.80	-18.65
6	26.62106	11.21	33.41	28.51	44.62	39.72	60.00	50.00	-15.38	-10.28

Remarks:

1. Q.P. and AV. are abbreviations of quasi-peak and average individually.
2. The emission levels of other frequencies were very low against the limit.
3. Margin value = Emission level – Limit value
4. Correction factor = Insertion loss + Cable loss
5. Emission Level = Correction Factor + Reading Value

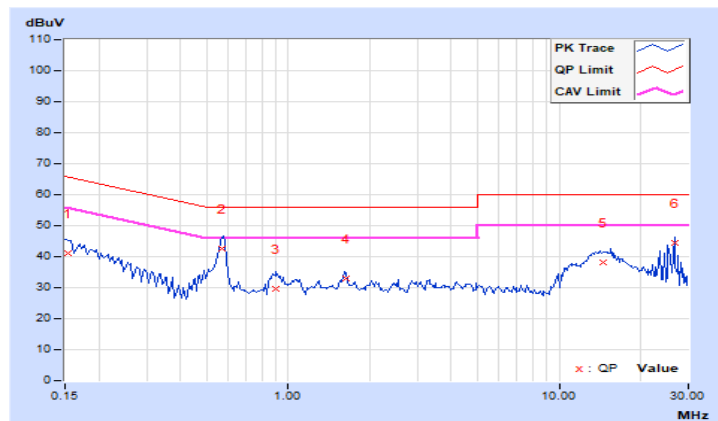

Frequency Range	150kHz ~ 30MHz	Detector Function & Resolution Bandwidth	Quasi-Peak (QP) / Average (AV), 9kHz
------------------------	----------------	---	--------------------------------------

Phase Of Power : Neutral (N)										
No	Frequency (MHz)	Correction Factor (dB)	Reading Value (dBuV)		Emission Level (dBuV)		Limit (dBuV)		Margin (dB)	
			Q.P.	AV.	Q.P.	AV.	Q.P.	AV.	Q.P.	AV.
1	0.15392	9.93	32.75	19.27	42.68	29.20	65.79	55.79	-23.11	-26.59
2	0.23205	9.94	24.82	10.54	34.76	20.48	62.38	52.38	-27.62	-31.90
3	0.57968	9.95	27.63	18.72	37.58	28.67	56.00	46.00	-18.42	-17.33
4	0.88043	9.96	14.70	2.46	24.66	12.42	56.00	46.00	-31.34	-33.58
5	14.17961	10.57	20.88	13.34	31.45	23.91	60.00	50.00	-28.55	-26.09
6	25.85939	10.86	24.67	18.21	35.53	29.07	60.00	50.00	-24.47	-20.93

Remarks:

1. Q.P. and AV. are abbreviations of quasi-peak and average individually.
2. The emission levels of other frequencies were very low against the limit.
3. Margin value = Emission level – Limit value
4. Correction factor = Insertion loss + Cable loss
5. Emission Level = Correction Factor + Reading Value

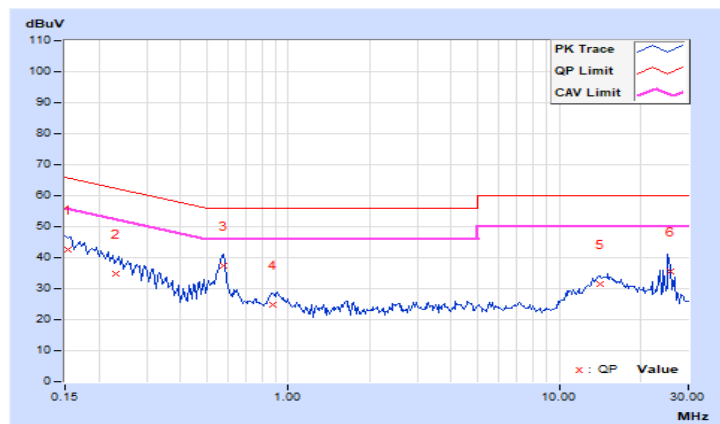

4.2.10 Test Results (Mode 4)

Frequency Range	150kHz ~ 30MHz	Detector Function & Resolution Bandwidth	Quasi-Peak (QP) / Average (AV), 9kHz
------------------------	----------------	---	--------------------------------------

Phase Of Power : Line (L)										
No	Frequency (MHz)	Correction Factor (dB)	Reading Value (dBuV)		Emission Level (dBuV)		Limit (dBuV)		Margin (dB)	
			Q.P.	AV.	Q.P.	AV.	Q.P.	AV.	Q.P.	AV.
1	0.15396	9.96	31.38	24.40	41.34	34.36	65.78	55.78	-24.44	-21.42
2	0.56795	9.98	32.61	26.22	42.59	36.20	56.00	46.00	-13.41	-9.80
3	0.89609	9.99	19.59	16.96	29.58	26.95	56.00	46.00	-26.42	-19.05
4	1.62893	10.03	22.91	18.89	32.94	28.92	56.00	46.00	-23.06	-17.08
5	14.52734	10.77	27.86	20.47	38.63	31.24	60.00	50.00	-21.37	-18.76
6	26.62107	11.21	33.21	28.03	44.42	39.24	60.00	50.00	-15.58	-10.76

Remarks:

1. Q.P. and AV. are abbreviations of quasi-peak and average individually.
2. The emission levels of other frequencies were very low against the limit.
3. Margin value = Emission level – Limit value
4. Correction factor = Insertion loss + Cable loss
5. Emission Level = Correction Factor + Reading Value

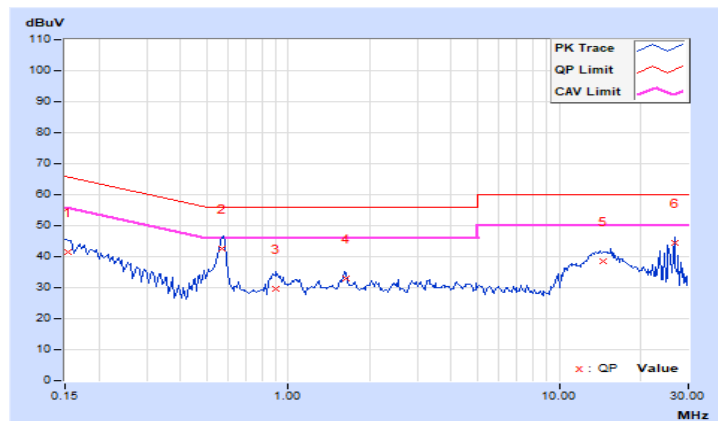

Frequency Range	150kHz ~ 30MHz	Detector Function & Resolution Bandwidth	Quasi-Peak (QP) / Average (AV), 9kHz
------------------------	----------------	---	--------------------------------------

Phase Of Power : Neutral (N)										
No	Frequency (MHz)	Correction Factor (dB)	Reading Value (dBuV)		Emission Level (dBuV)		Limit (dBuV)		Margin (dB)	
			Q.P.	AV.	Q.P.	AV.	Q.P.	AV.	Q.P.	AV.
1	0.15395	9.93	32.68	19.38	42.61	29.31	65.78	55.78	-23.17	-26.47
2	0.23206	9.94	24.57	10.62	34.51	20.56	62.38	52.38	-27.87	-31.82
3	0.57963	9.95	27.31	18.79	37.26	28.74	56.00	46.00	-18.74	-17.26
4	0.88041	9.96	14.08	2.34	24.04	12.30	56.00	46.00	-31.96	-33.70
5	14.17969	10.57	20.29	13.41	30.86	23.98	60.00	50.00	-29.14	-26.02
6	25.85932	10.86	24.91	18.69	35.77	29.55	60.00	50.00	-24.23	-20.45

Remarks:

1. Q.P. and AV. are abbreviations of quasi-peak and average individually.
2. The emission levels of other frequencies were very low against the limit.
3. Margin value = Emission level – Limit value
4. Correction factor = Insertion loss + Cable loss
5. Emission Level = Correction Factor + Reading Value

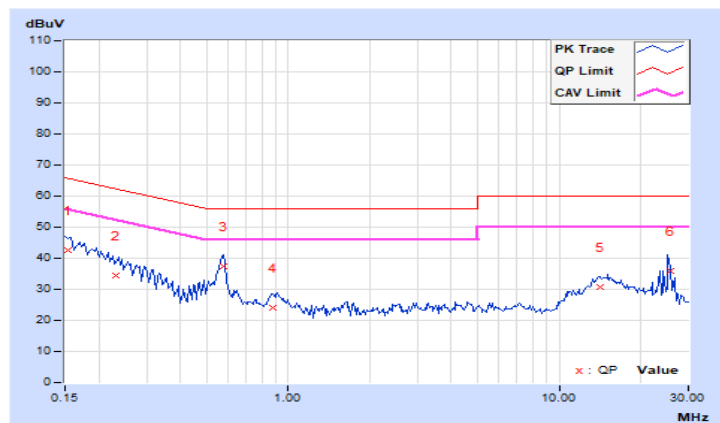

4.2.11 Test Results (Mode 5)

Frequency Range	150kHz ~ 30MHz	Detector Function & Resolution Bandwidth	Quasi-Peak (QP) / Average (AV), 9kHz
------------------------	----------------	---	--------------------------------------

Phase Of Power : Line (L)										
No	Frequency (MHz)	Correction Factor (dB)	Reading Value (dBuV)		Emission Level (dBuV)		Limit (dBuV)		Margin (dB)	
			Q.P.	AV.	Q.P.	AV.	Q.P.	AV.	Q.P.	AV.
1	0.15392	9.96	31.79	24.65	41.75	34.61	65.79	55.79	-24.04	-21.18
2	0.56791	9.98	32.85	26.36	42.83	36.34	56.00	46.00	-13.17	-9.66
3	0.89606	9.99	19.69	16.81	29.68	26.80	56.00	46.00	-26.32	-19.20
4	1.62894	10.03	22.83	18.47	32.86	28.50	56.00	46.00	-23.14	-17.50
5	14.52737	10.77	27.70	20.29	38.47	31.06	60.00	50.00	-21.53	-18.94
6	26.62102	11.21	33.03	28.10	44.24	39.31	60.00	50.00	-15.76	-10.69

Remarks:

1. Q.P. and AV. are abbreviations of quasi-peak and average individually.
2. The emission levels of other frequencies were very low against the limit.
3. Margin value = Emission level – Limit value
4. Correction factor = Insertion loss + Cable loss
5. Emission Level = Correction Factor + Reading Value

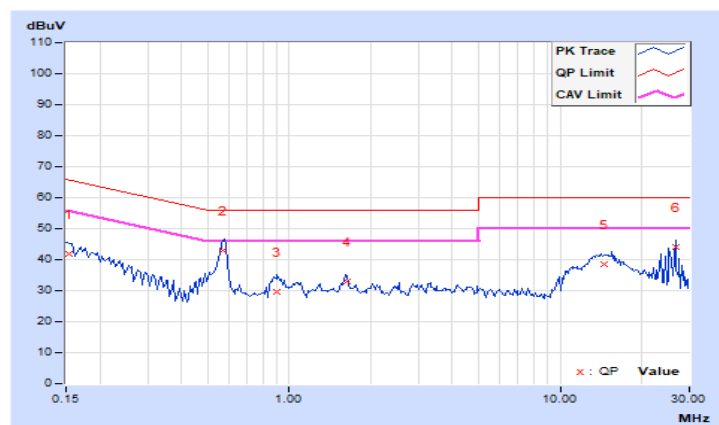

Frequency Range	150kHz ~ 30MHz	Detector Function & Resolution Bandwidth	Quasi-Peak (QP) / Average (AV), 9kHz
------------------------	----------------	---	--------------------------------------

Phase Of Power : Neutral (N)										
No	Frequency (MHz)	Correction Factor (dB)	Reading Value (dBuV)		Emission Level (dBuV)		Limit (dBuV)		Margin (dB)	
			Q.P.	AV.	Q.P.	AV.	Q.P.	AV.	Q.P.	AV.
1	0.15391	9.93	32.54	19.67	42.47	29.60	65.79	55.79	-23.32	-26.19
2	0.23202	9.94	24.26	10.56	34.20	20.50	62.38	52.38	-28.18	-31.88
3	0.57968	9.95	27.73	18.81	37.68	28.76	56.00	46.00	-18.32	-17.24
4	0.88043	9.96	14.81	2.49	24.77	12.45	56.00	46.00	-31.23	-33.55
5	14.17965	10.57	20.54	13.20	31.11	23.77	60.00	50.00	-28.89	-26.23
6	25.85937	10.86	24.86	18.53	35.72	29.39	60.00	50.00	-24.28	-20.61

Remarks:

1. Q.P. and AV. are abbreviations of quasi-peak and average individually.
2. The emission levels of other frequencies were very low against the limit.
3. Margin value = Emission level – Limit value
4. Correction factor = Insertion loss + Cable loss
5. Emission Level = Correction Factor + Reading Value

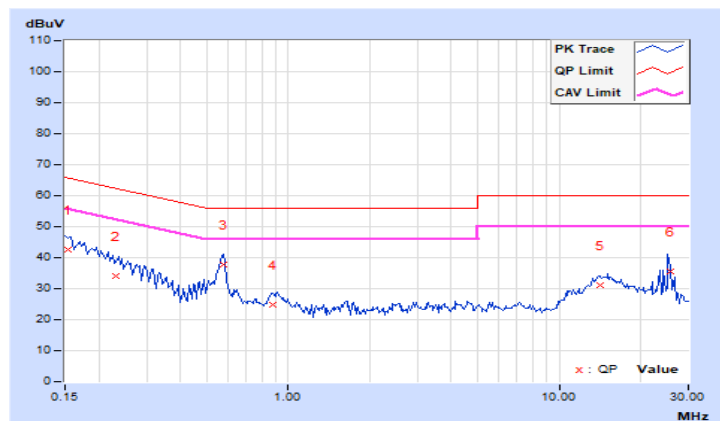

4.2.12 Test Results (Mode 6)

Frequency Range	150kHz ~ 30MHz	Detector Function & Resolution Bandwidth	Quasi-Peak (QP) / Average (AV), 9kHz
------------------------	----------------	---	--------------------------------------

Phase Of Power : Line (L)										
No	Frequency (MHz)	Correction Factor (dB)	Reading Value (dBuV)		Emission Level (dBuV)		Limit (dBuV)		Margin (dB)	
			Q.P.	AV.	Q.P.	AV.	Q.P.	AV.	Q.P.	AV.
1	0.15398	9.96	31.42	24.62	41.38	34.58	65.78	55.78	-24.40	-21.20
2	0.56790	9.98	32.81	26.34	42.79	36.32	56.00	46.00	-13.21	-9.68
3	0.89605	9.99	19.29	16.89	29.28	26.88	56.00	46.00	-26.72	-19.12
4	1.62899	10.03	22.73	18.40	32.76	28.43	56.00	46.00	-23.24	-17.57
5	14.52735	10.77	27.56	20.33	38.33	31.10	60.00	50.00	-21.67	-18.90
6	26.62107	11.21	33.08	28.17	44.29	39.38	60.00	50.00	-15.71	-10.62

Remarks:

1. Q.P. and AV. are abbreviations of quasi-peak and average individually.
2. The emission levels of other frequencies were very low against the limit.
3. Margin value = Emission level – Limit value
4. Correction factor = Insertion loss + Cable loss
5. Emission Level = Correction Factor + Reading Value

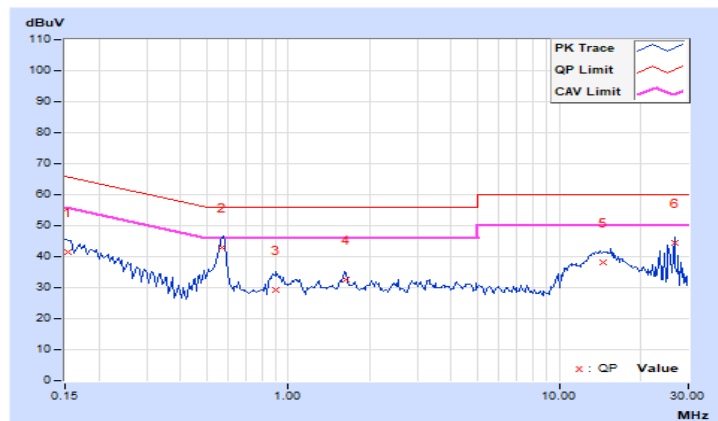

Frequency Range	150kHz ~ 30MHz	Detector Function & Resolution Bandwidth	Quasi-Peak (QP) / Average (AV), 9kHz
------------------------	----------------	---	--------------------------------------

Phase Of Power : Neutral (N)										
No	Frequency (MHz)	Correction Factor (dB)	Reading Value (dBuV)		Emission Level (dBuV)		Limit (dBuV)		Margin (dB)	
			Q.P.	AV.	Q.P.	AV.	Q.P.	AV.	Q.P.	AV.
1	0.15390	9.93	32.79	19.60	42.72	29.53	65.79	55.79	-23.07	-26.26
2	0.23208	9.94	24.82	10.02	34.76	19.96	62.37	52.37	-27.61	-32.41
3	0.57965	9.95	27.61	18.43	37.56	28.38	56.00	46.00	-18.44	-17.62
4	0.88047	9.96	14.74	2.13	24.70	12.09	56.00	46.00	-31.30	-33.91
5	14.17963	10.57	20.38	13.27	30.95	23.84	60.00	50.00	-29.05	-26.16
6	25.85931	10.86	24.29	18.46	35.15	29.32	60.00	50.00	-24.85	-20.68

Remarks:

1. Q.P. and AV. are abbreviations of quasi-peak and average individually.
2. The emission levels of other frequencies were very low against the limit.
3. Margin value = Emission level – Limit value
4. Correction factor = Insertion loss + Cable loss
5. Emission Level = Correction Factor + Reading Value

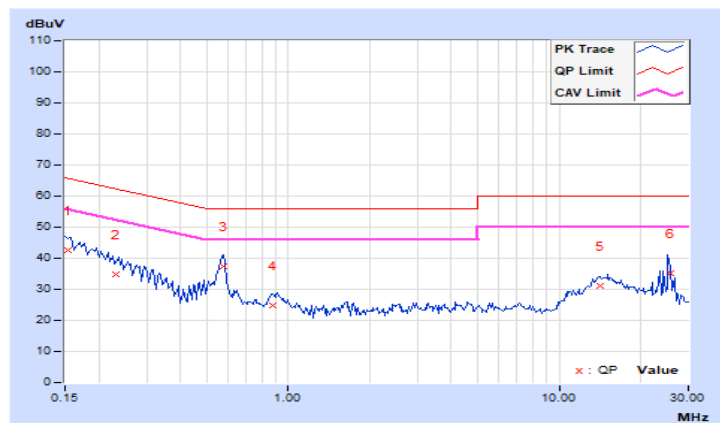

4.3 Conducted Out of Band Emission Measurement

4.3.1 Limits of Conducted Out of Band Emission Measurement

Below 20dB of the highest emission level of operating band (in 100kHz Resolution Bandwidth).

4.3.2 Test Setup

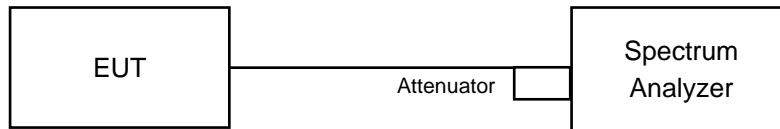

4.3.3 Test Instruments

Refer to section 4.1.2 to get information of above instrument.

4.3.4 Test Procedures

MEASUREMENT PROCEDURE REF

1. Set the RBW = 100 kHz.
2. Set the VBW \geq 300 kHz.
3. Detector = peak.
4. Sweep time = auto couple.
5. Trace mode = max hold.
6. Allow trace to fully stabilize.
7. Use the peak marker function to determine the maximum power level in any 100 kHz band segment within the fundamental EBW.

MEASUREMENT PROCEDURE OOB

1. Set RBW = 100 kHz.
2. Set VBW \geq 300 kHz.
3. Detector = peak.
4. Sweep = auto couple.
5. Trace Mode = max hold.
6. Allow trace to fully stabilize.
7. Use the peak marker function to determine the maximum amplitude level.

4.3.5 Deviation from Test Standard

No deviation.

4.3.6 EUT Operating Conditions

The software provided by client to enable the EUT under transmission condition continuously at specific channel frequencies individually.

4.3.7 Test Results (Mode 1)

The spectrum plots are attached on the following pages. D1 line indicates the highest level, and D2 line indicates the 20dB offset below D1. It shows compliance with the requirement.

2.4GHz: 802.11b_CH1 + 5GHz: 802.11be (EHT20)_CH116

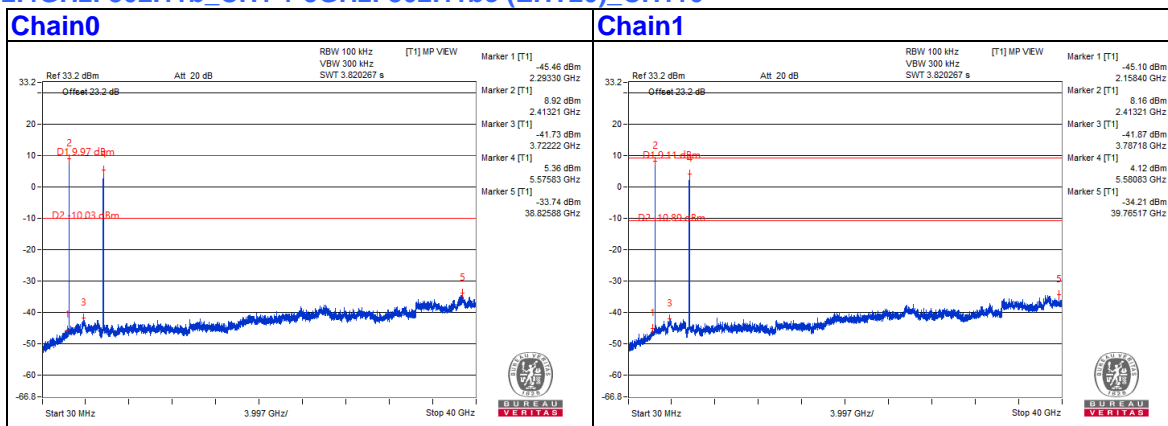

4.3.8 Test Results (Mode 2)

The spectrum plots are attached on the following pages. D1 line indicates the highest level, and D2 line indicates the 20dB offset below D1. It shows compliance with the requirement.

2.4GHz: 802.11b_CH1 + 6GHz: 802.11be (EHT20)_CH45

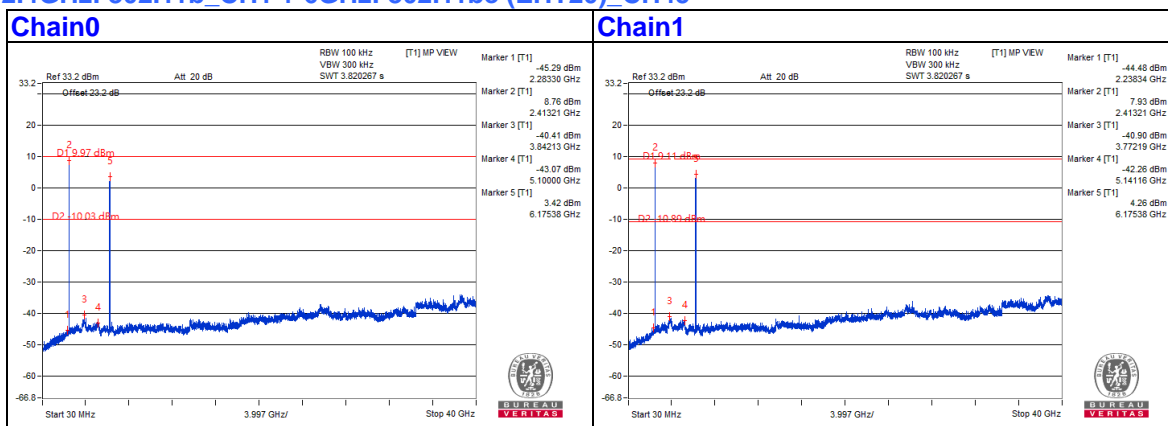

4.3.9 Test Results (Mode 3)

The spectrum plots are attached on the following pages. D1 line indicates the highest level, and D2 line indicates the 20dB offset below D1. It shows compliance with the requirement.

BT-LE_CH19 + 5GHz: 802.11be (EHT20)_CH116

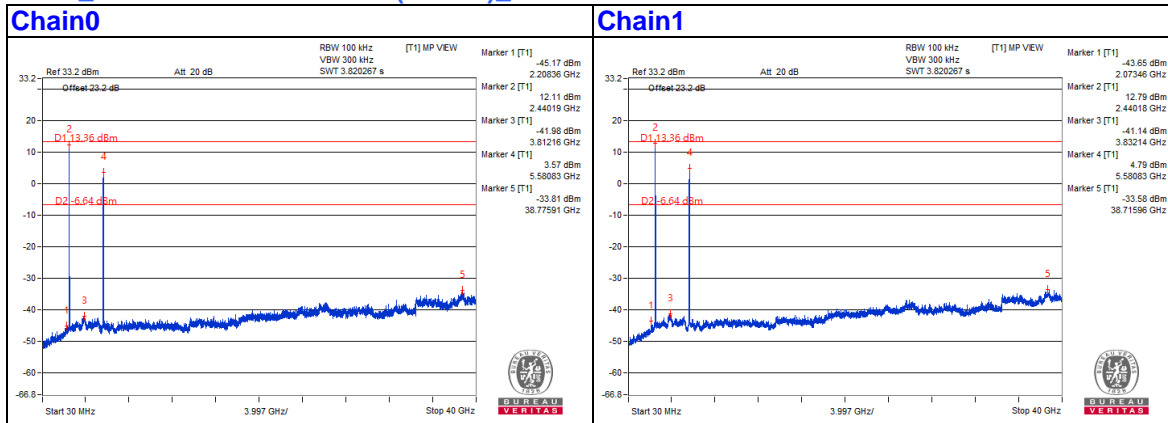

4.3.10 Test Results (Mode 4)

The spectrum plots are attached on the following pages. D1 line indicates the highest level, and D2 line indicates the 20dB offset below D1. It shows compliance with the requirement.

BT-LE_CH19 + 6GHz: 802.11be (EHT20)_CH45

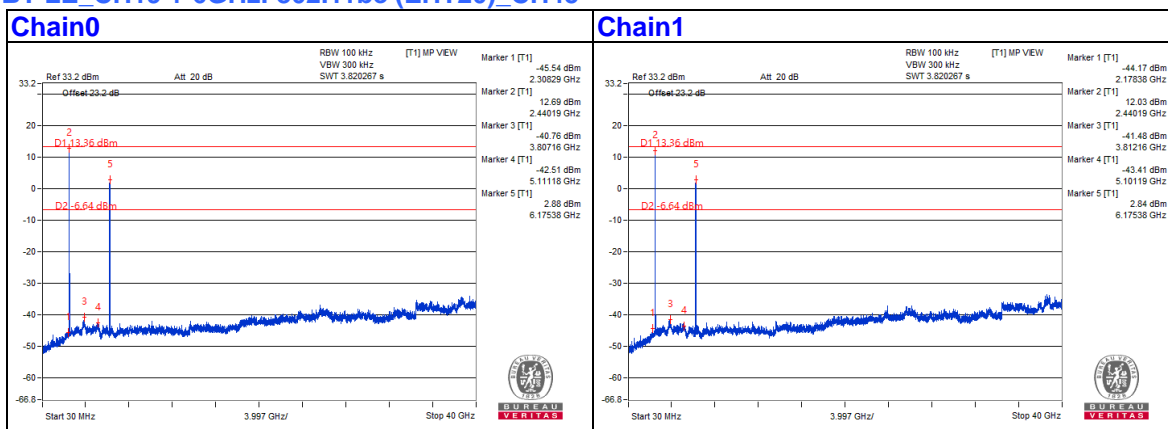

4.3.11 Test Results (Mode 5)

The spectrum plots are attached on the following pages. D1 line indicates the highest level, and D2 line indicates the 20dB offset below D1. It shows compliance with the requirement.

**5GHz: 802.11be (EHT20)_CH116 (U-NII-1, U-NII-2A) +
5GHz: 802.11be (EHT20)_CH116(U-NII-2C, U-NII-3, U-NII-4) + BT-LE_CH19**

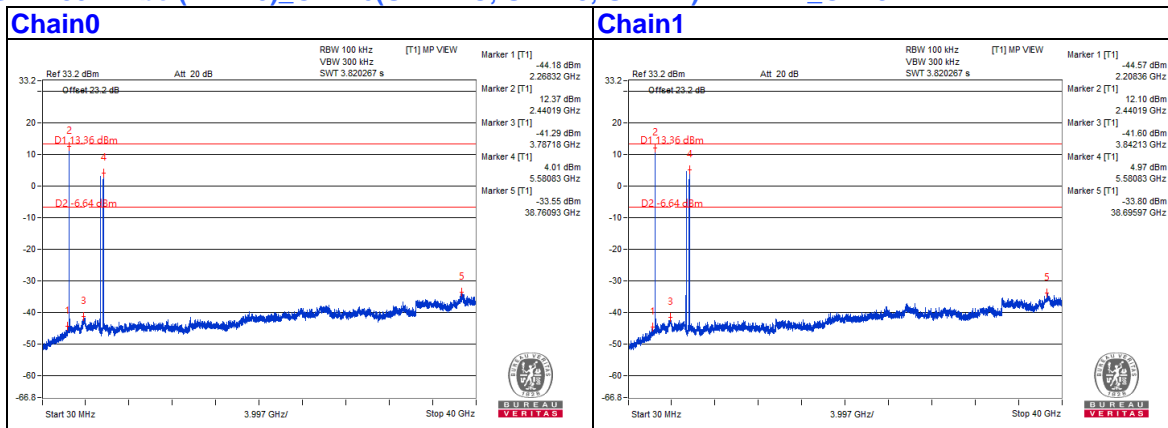

4.3.12 Test Results (Mode 6)

The spectrum plots are attached on the following pages. D1 line indicates the highest level, and D2 line indicates the 20dB offset below D1. It shows compliance with the requirement.

5GHz: 802.11be (EHT20)_CH116 (U-NII-1, U-NII-2A) + 6GHz: 802.11be (EHT20)_CH45 + BT-LE_CH19

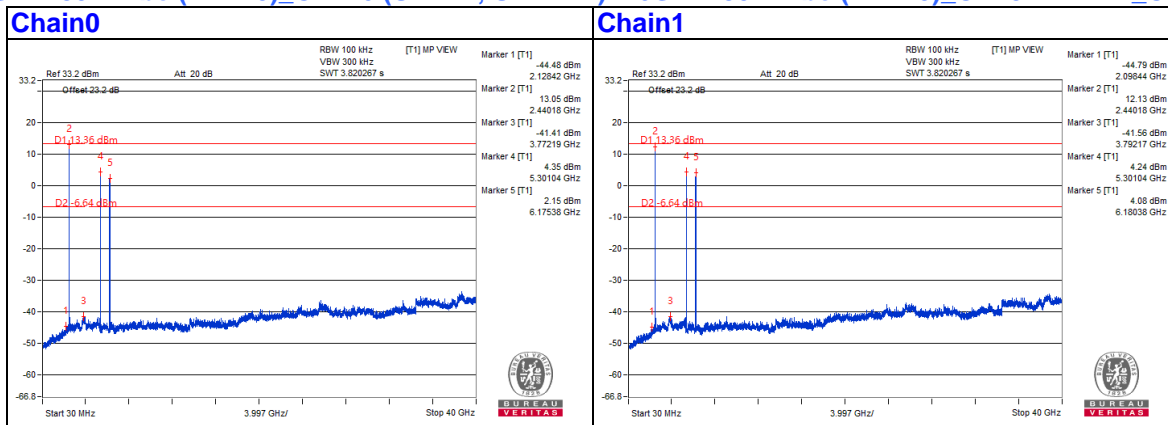

5 Pictures of Test Arrangements

Please refer to the attached file (Test Setup Photo).

Appendix – Information of the Testing Laboratories

We, Bureau Veritas Consumer Products Services (H.K.) Ltd., Taoyuan Branch, were founded in 1988 to provide our best service in EMC, Radio, Telecom and Safety consultation. Our laboratories are FCC recognized accredited test firms and accredited according to ISO/IEC 17025.

If you have any comments, please feel free to contact us at the following:

Lin Kou EMC/RF Lab

Tel: 886-2-26052180

Fax: 886-2-26051924

Hsin Chu EMC/RF/Telecom Lab

Tel: 886-3-6668565

Fax: 886-3-6668323

Hwa Ya EMC/RF/Safety Lab

Tel: 886-3-3183232

Fax: 886-3-3270892

Email: service.adt@tw.bureauveritas.com

Web Site: www.bureauveritas-adt.com

The address and road map of all our labs can be found in our web site also.

--- END ---