

ANTENNA INFORMATION

OEM	Lenovo
ODM	Wistron
Platform model name	TP00161A; ThinkPad T14s Gen 6 Snapdragon
Platform type (ex: regular NB, convertible PC, AIO...etc)	Regular NB
SAR minimum separation (mm)	9.8 mm

Antenna manufacturer	Speed	
Address	25F., No. 95, Xinpu 6th St., Taoyuan Dist., Taoyuan City 33044, Taiwan	
Antenna Part number	Main: 025.902D7.0001	Aux: 025.902D7.0001
Antenna type (ex: PIFA, Dipole...etc)	PIFA	

Antenna Peak gain w/ cable loss (dBi)*										
	2.4GHz 2400-2483.5 MHz	5.2GHz 5150-5250MHz	5.3GHz 5250-5350MHz	5.6GHz 5470-5725MHz	5.8GHz 5725-5850MHz	5.9GHz 5850-5895MHz	6.2GHz 5925-6425MHz	6.5GHz 6425-6525MHz	6.7GHz 6525-6875MHz	7.0 GHz 6875-7125MHz
Main	2.22	1.92	1.71	3.89	3.29	3.01	4.48	3.64	4.16	3.24
Aux	2.37	2.48	1.91	3.53	3.70	3.00	3.80	2.85	4.06	3.70

Cable Assembly Part Number and Information					
	Cable PN	Cable length(cm)	Cable diameter(mm)	Impedance(ohm)	Connector type
Main	SY113L/50-001	14.3	1.13	50	I-Pex:20565-001R-13
Aux	SY113L/50-016	25.2	1.13	50	I-Pex:20565-001R-13

* 3D Antenna Peak Gain required being test in system basis.

Table of Contents

- Cover page..... 1
- 1. Document Revision History..... 3
- 2. Test & System Description
 - 2.1 Measurement Method and System..... 4
 - 2.2 Test setup..... 4
 - 2.3 Equipment list..... 5
- 3. Radiation characteristics of antenna loaded in Host Platform..... 6
- Annex A. Photographs
 - A.1 Setup Photo..... 16
 - A.2 Test sample..... 17
- Annex B. Antenna Location
 - B.1 Antenna Host Platform Location Information..... 19
 - B.2 Antenna dimensional information for SAR evaluation..... 20

1. Document Revision History

Revision #	Revision Details	Issued Date
Rev. 01	First Issue	2024.03.08

2. Test & System Description

2.1 Measurement Method and System

The gain measurement shall follow by following conditions:

- It is required that all the antenna gain to be measured spherically and computed by spatial average be computed of the resultant gain.
- During gain measurement, all other antennas not under test should be terminated by 50 Ohm load in end of cable.
- Space points of 3D gain measurement are increase by specific steps from Theta 0~180 degrees, and Phi, 0~360 degrees, as figure below. The increments steps are different steps are different by antenna functions.

Theta Start	0 degree	Phi Start	0 degree
Theta Stop	165 degree	Phi Stop	345 degree
Theta Increment	15 degree	Phi Increment	15 degree

2.2 Test setup

The testing of antenna gain should be made at a CTIA qualified lab with an RF anechoic chamber with at least 3-meter separation from the receive antenna to the antenna under test. The antenna gain report from unqualified lab can't be referenced a passing. Besides, all test equipment including horn antennas, adapters, cables, network analyzers, and receivers shall be calibrated per manufacturer's minimum calibration requirements.

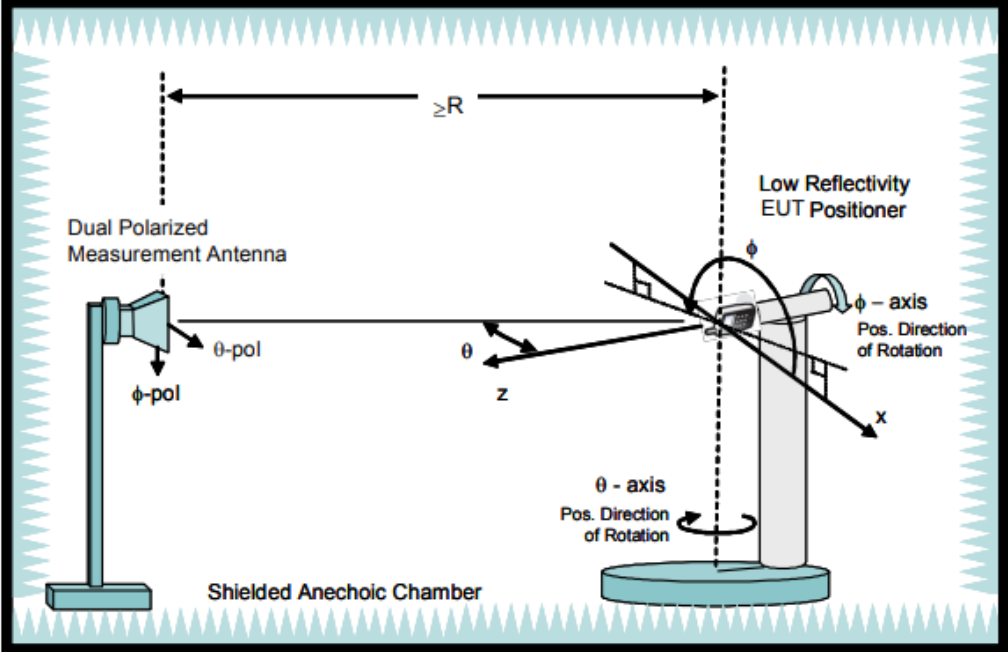

2.3 Equipment list

Device	Type/Model	Serial #	Manufacturer	Cal. Date	Cal. Due Date
Anechoic Chamber	AMS8500	-	ETS-Lindgren	22-Jun-22	10-Jul-24
Turn Table	2117-7200	SN00231447	ETS-Lindgren	22-Jun-22	10-Jul-24
Switch & Positioning systems	EMCenter	SN00242606	ETS-Lindgren	22-Jun-22	10-Jul-24
Measurement SW	EMQuest V1.15 build 27347	SN1802	ETS-Lindgren	22-Jun-22	10-Jul-24
Horn antenna	3164-10	SN00246202	ETS-Lindgren	22-Jun-22	10-Jul-24
Vector Network Analyzer	E5071C	PN5188-4462	Keysight	30-May-22	30-Nov-24
Cable 7.5m 400MHz to 18GHz(H-pol)	SS402	00100A1F5A1XXS	WOKEN	22-Jun-22	10-Nov-24
Cable 7.5m 400MHz to 18GHz(V-pol)	SS402	00100A1F5A1XXS	WOKEN	22-Jun-22	10-Nov-24
Cable 14m 400MHz to 18GHz	SS402	00100A1F5A1XXS	WOKEN	22-Jun-22	10-Nov-24
Temp & Humidity Logger	830	SN84972	PROVA	16-Jul-22	10-Jul-24

3. Radiation characteristics of antenna loaded in Host Platform

Main Antenna

Max Antenna 3D Radiation Pattern 2400 – 2483.5 MHz

Frequency (MHz)	Peak Gain w/ Cable Loss (dBi)
2400-2483.5	2.22

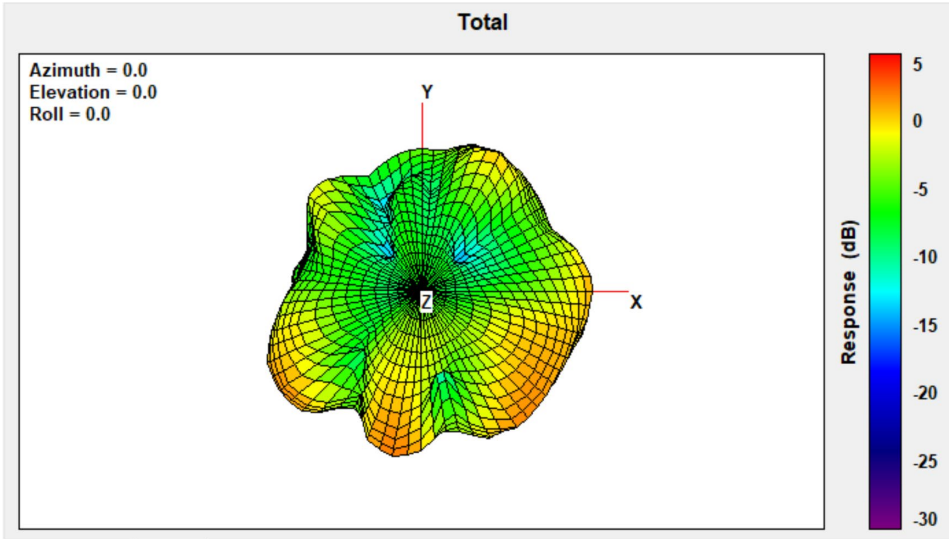

Max Antenna 3D Radiation Pattern 5150-5250 MHz

Frequency (MHz)	Peak Gain w/ Cable Loss (dBi)
5150-5250	1.92

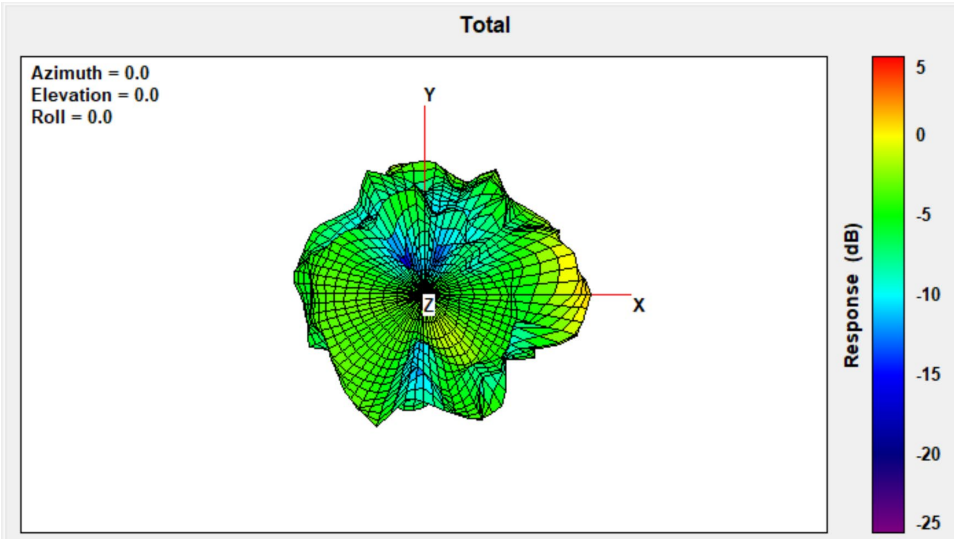

Max Antenna 3D Radiation Pattern 5250-5350 MHz

Frequency (MHz)	Peak Gain w/ Cable Loss (dBi)
5250-5350	1.71

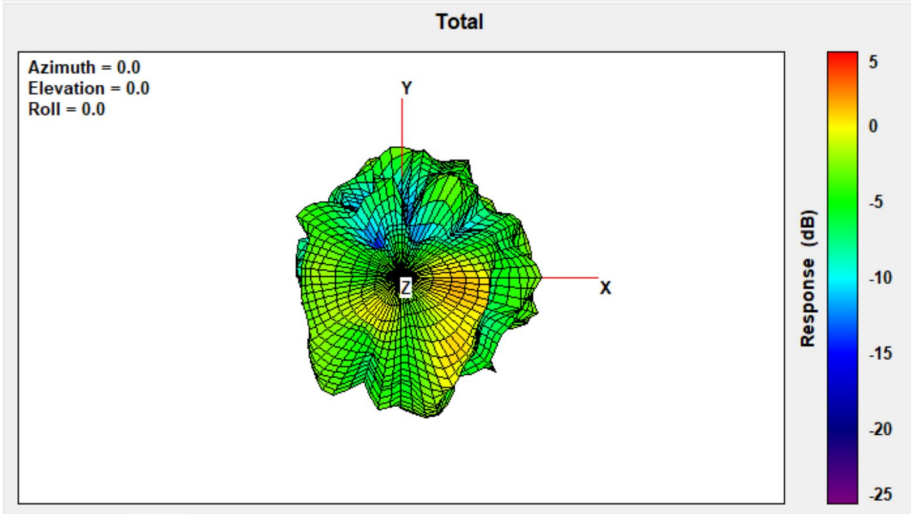

Max Antenna 3D Radiation Pattern 5470-5725 MHz

Frequency (MHz)	Peak Gain w/ Cable Loss (dBi)
5470-5725	3.89

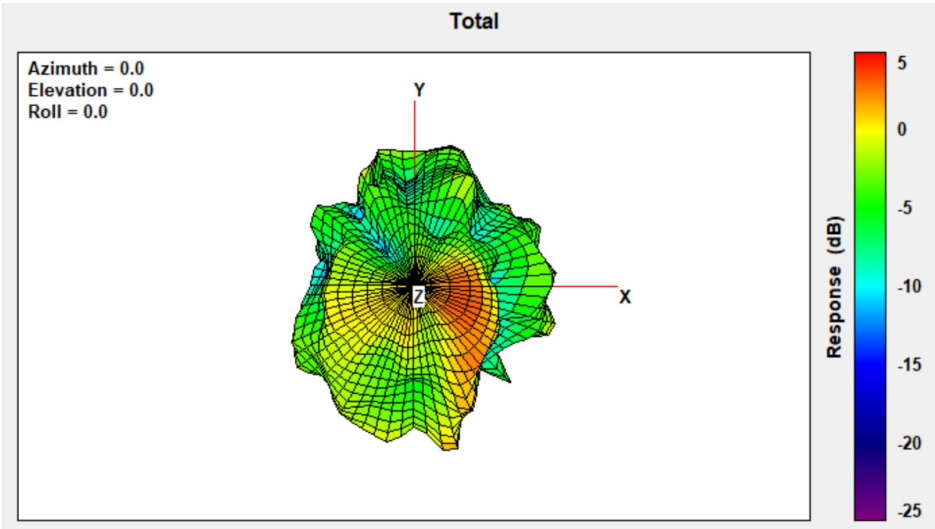

Max Antenna 3D Radiation Pattern 5725-5850 MHz

Frequency (MHz)	Peak Gain w/ Cable Loss (dBi)
5725-5850	3.29

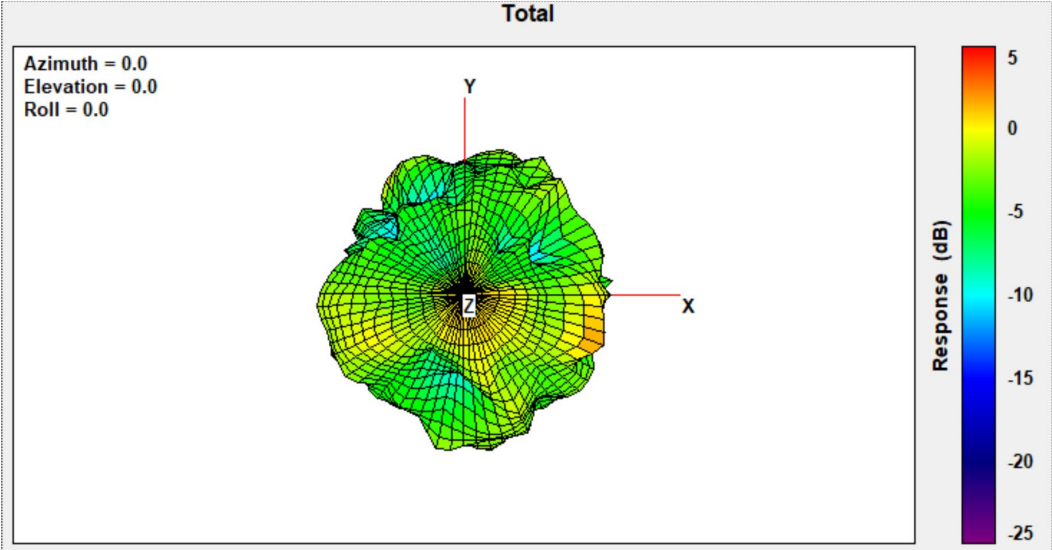

Max Antenna 3D Radiation Pattern 5850-5895 MHz

Frequency (MHz)	Peak Gain w/ Cable Loss (dBi)
5850-5895	3.01

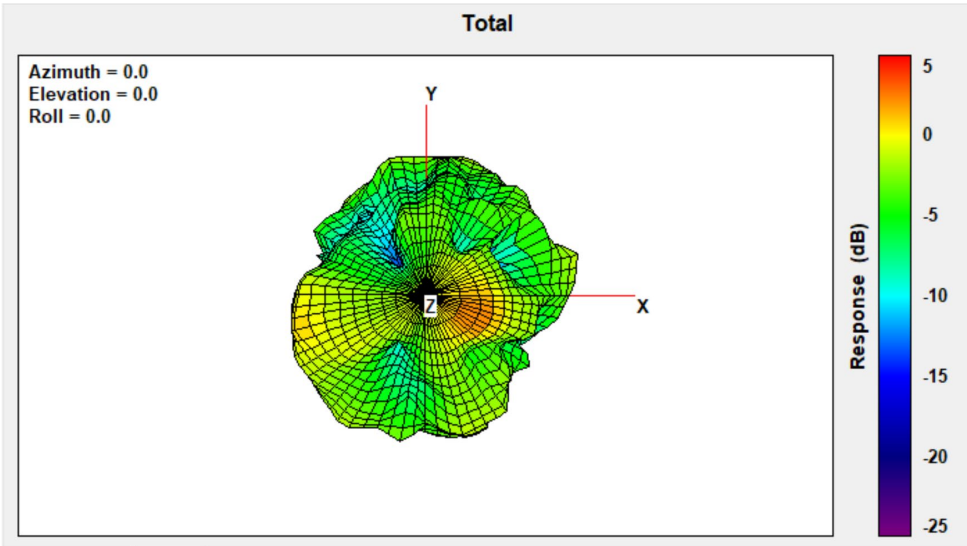

Max Antenna 3D Radiation Pattern 5925-6425 MHz

Frequency (MHz)	Peak Gain w/ Cable Loss (dBi)
5925-6425	4.48

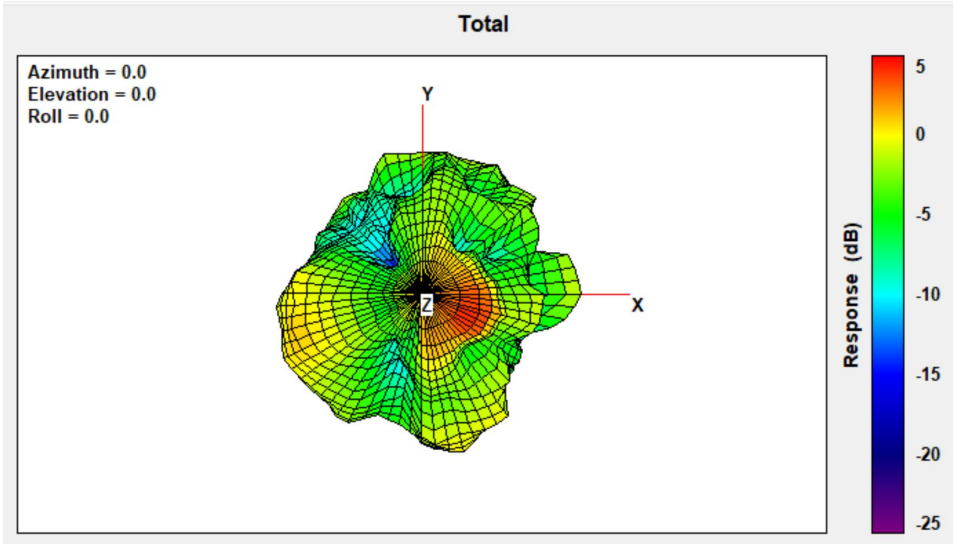

Max Antenna 3D Radiation Pattern 6425-6525 MHz

Frequency (MHz)	Peak Gain w/ Cable Loss (dBi)
6425-6525	3.64

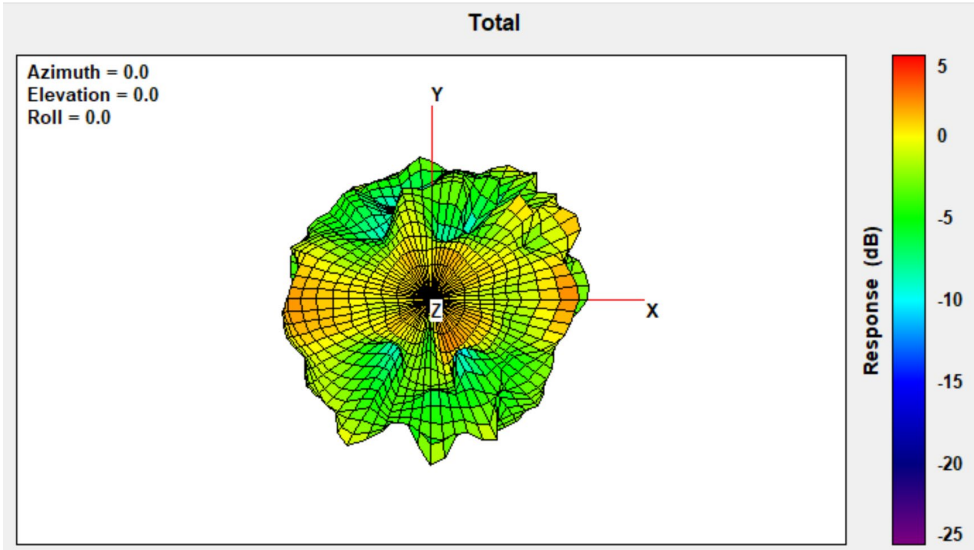

Max Antenna 3D Radiation Pattern 6525-6875 MHz

Frequency (MHz)	Peak Gain w/ Cable Loss (dBi)
6525-6875	4.16

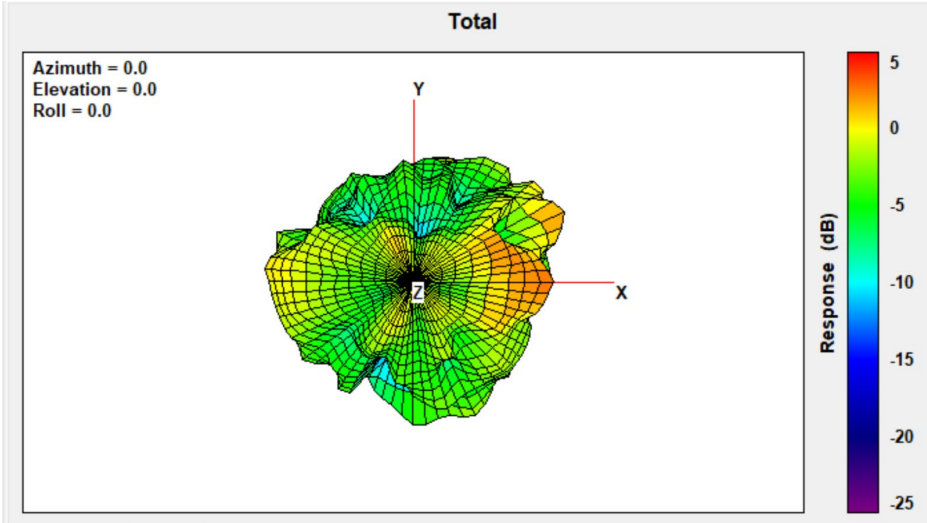

Max Antenna 3D Radiation Pattern 6875-7125 MHz

Frequency (MHz)	Peak Gain w/ Cable Loss (dBi)
6875-7125	3.24

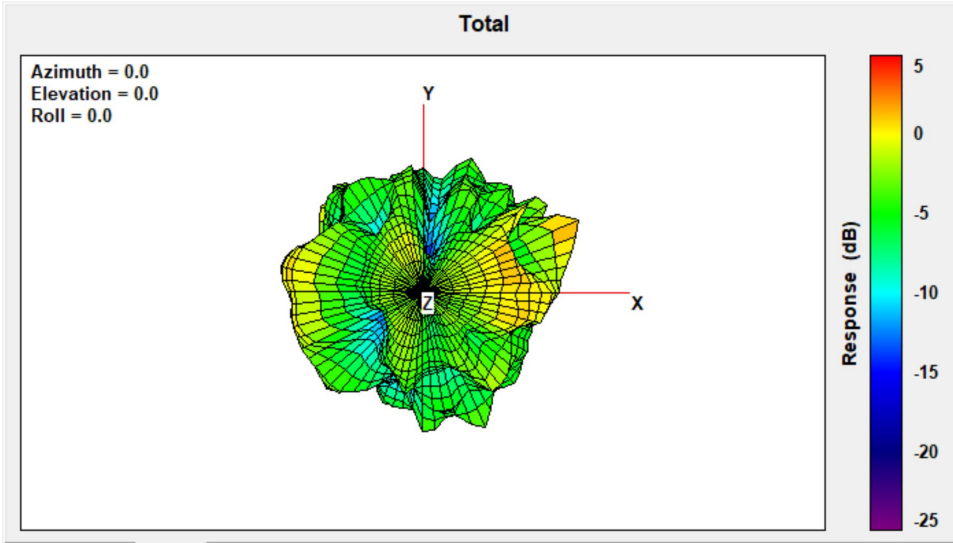

Auxiliary Antenna

Max Antenna 3D Radiation Pattern 2400 – 2483.5 MHz

Frequency (MHz)	Peak Gain w/ Cable Loss (dBi)
2400-2483.5	2.37

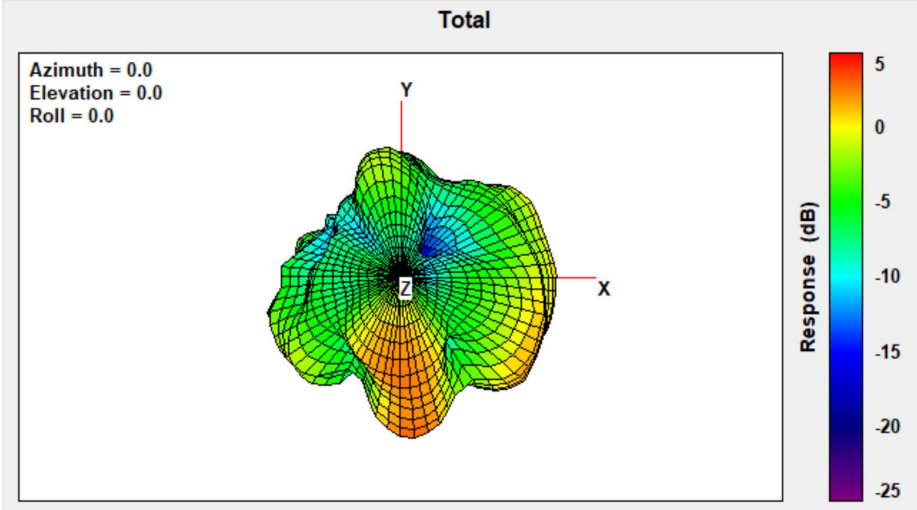

Max Antenna 3D Radiation Pattern 5150-5250 MHz

Frequency (MHz)	Peak Gain w/ Cable Loss (dBi)
5150-5250	2.48

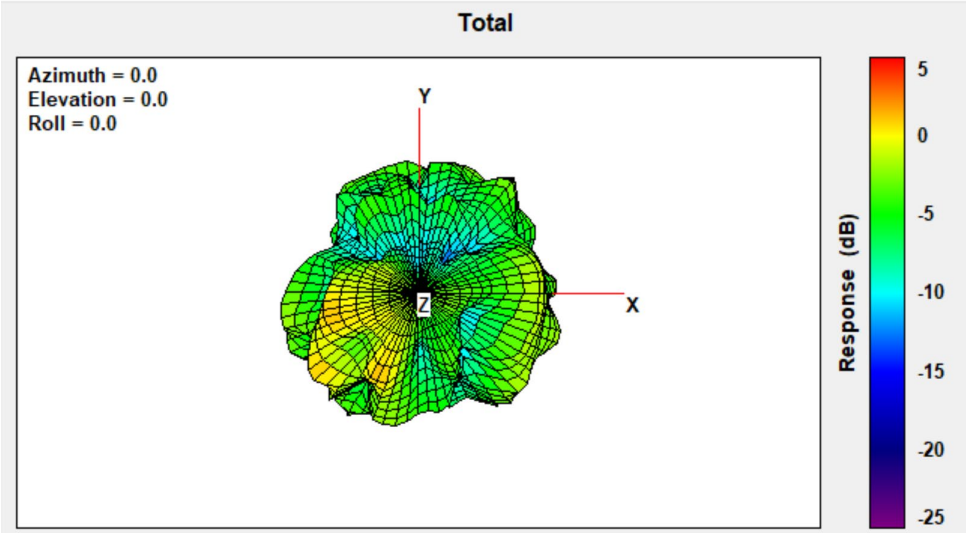

Max Antenna 3D Radiation Pattern 5250-5350 MHz

Frequency (MHz)	Peak Gain w/ Cable Loss (dBi)
5250-5350	1.91

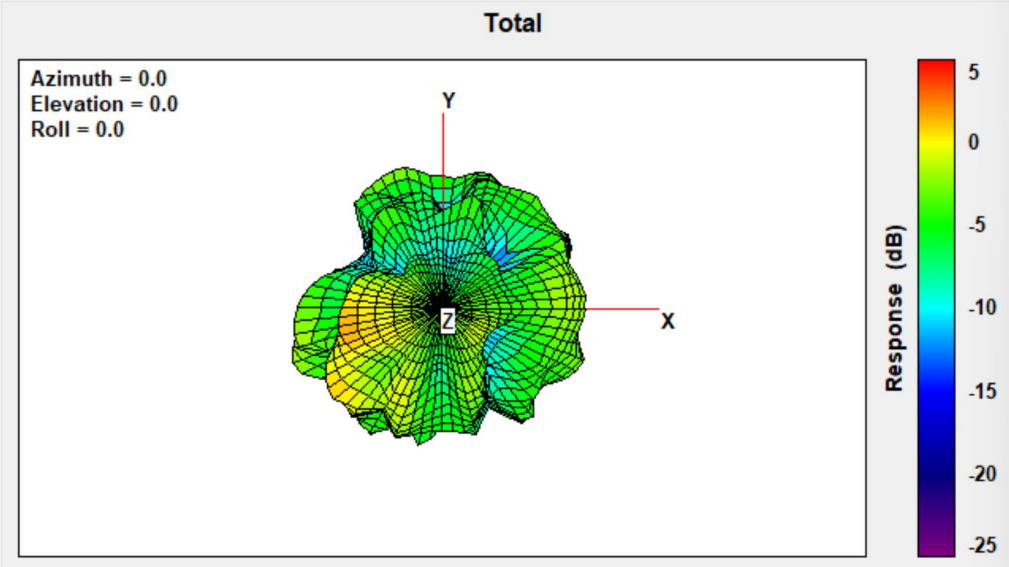

Max Antenna 3D Radiation Pattern 5470-5725 MHz

Frequency (MHz)	Peak Gain w/ Cable Loss (dBi)
5470-5725	3.53

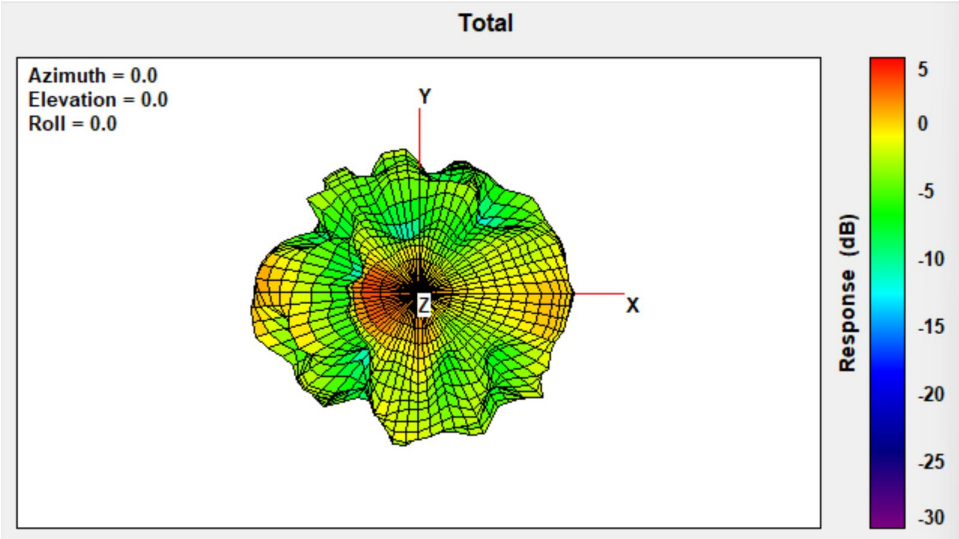

Max Antenna 3D Radiation Pattern 5725-5850 MHz

Frequency (MHz)	Peak Gain w/ Cable Loss (dBi)
5725-5850	3.70

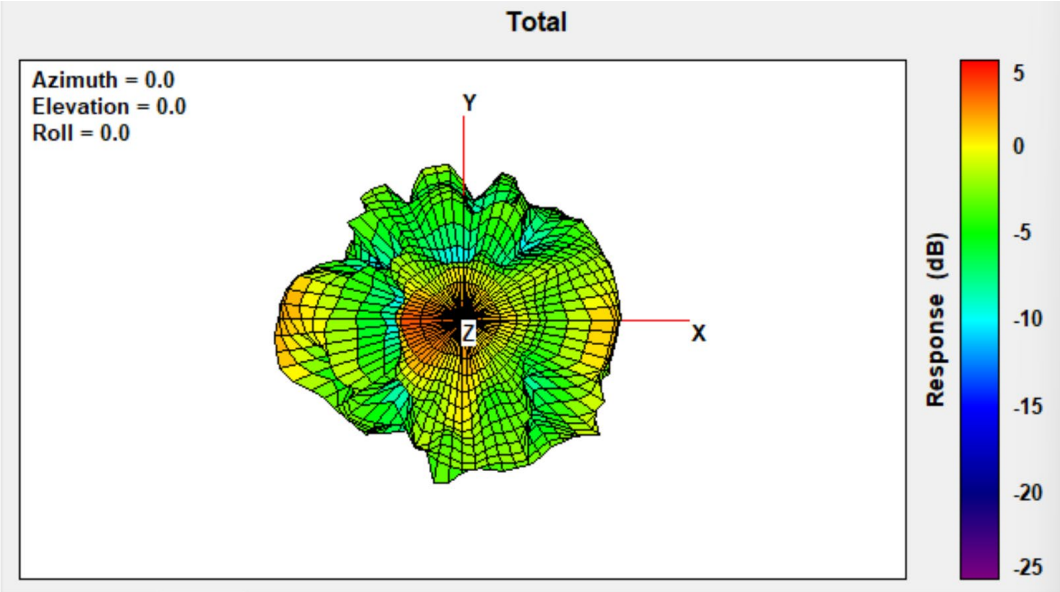

Max Antenna 3D Radiation Pattern 5850-5895 MHz

Frequency (MHz)	Peak Gain w/ Cable Loss (dBi)
5850-5895	3.00

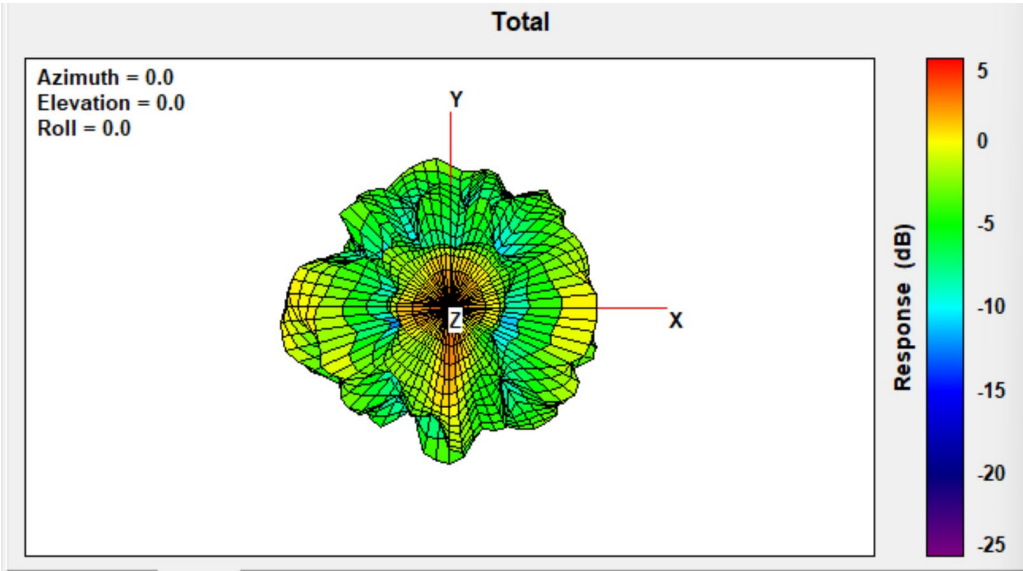

Max Antenna 3D Radiation Pattern 5925-6425 MHz

Frequency (MHz)	Peak Gain w/ Cable Loss (dBi)
5925-6425	3.80

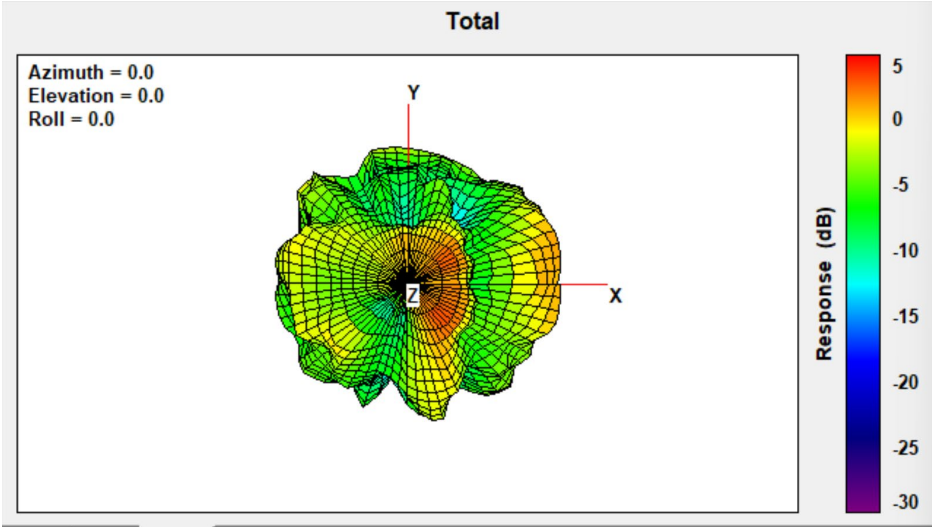

Max Antenna 3D Radiation Pattern 6425-6525 MHz

Frequency (MHz)	Peak Gain w/ Cable Loss (dBi)
6425-6525	2.85

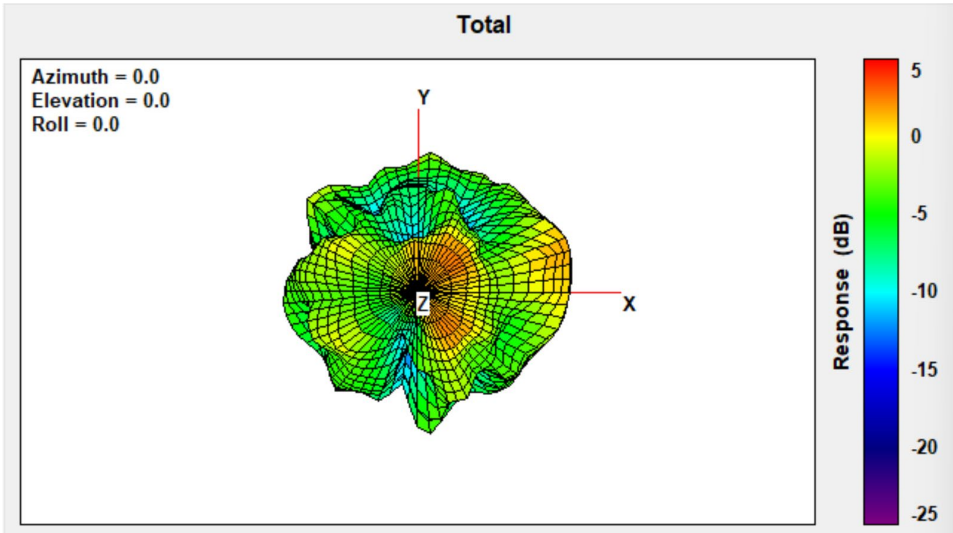

Max Antenna 3D Radiation Pattern 6525-6875 MHz

Frequency (MHz)	Peak Gain w/ Cable Loss (dBi)
6525-6875	4.06

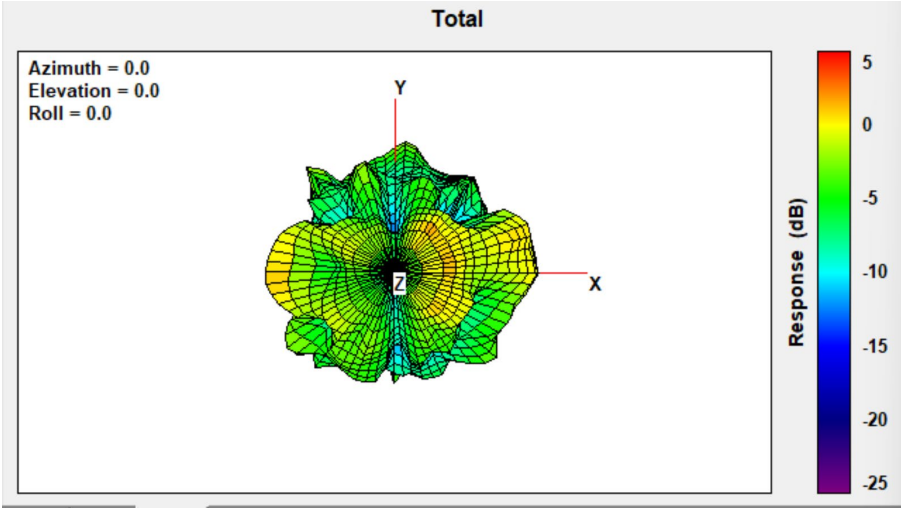

Max Antenna 3D Radiation Pattern 6875-7125 MHz

Frequency (MHz)	Peak Gain w/ Cable Loss (dBi)
6875-7125	3.70

