



FCC RADIO TEST REPORT

FCC ID : J9C-M2X75
Equipment : Module
Brand Name : Qualcomm
Model Name : M2X75
Applicant : Qualcomm Technologies, Inc.
5775 Morehouse Drive, San Diego, California 92121, United States
Manufacturer : Qualcomm Technologies, Inc.
5775 Morehouse Drive, San Diego, California 92121, United States
Standard : FCC 47 CFR Part 2, 96

The product was received on Apr. 09, 2024 and testing was performed from Apr. 10, 2024 to Jul. 27, 2024. We, Sporton International Inc. EMC & Wireless Communications Laboratory, would like to declare that the tested sample has been evaluated in accordance with the test procedures given in ANSI / TIA-603-E and has been in compliance with the applicable technical standards.

The test results in this report apply exclusively to the tested model / sample. Without written approval from Sporton International Inc. EMC & Wireless Communications Laboratory, the test report shall not be reproduced except in full.

Approved by: Louis Wu

Sporton International Inc. EMC & Wireless Communications Laboratory

No. 52, Huaya 1st Rd., Guishan Dist., Taoyuan City 333, Taiwan (R.O.C.)



Table of Contents

History of this test report.....3
Summary of Test Result.....4
1 General Description5
1.1 Product Feature of Equipment Under Test.....5
1.2 Modification of EUT5
1.3 Testing Site.....6
1.4 Applied Standards7
2 Test Configuration of Equipment Under Test8
2.1 Test Mode.....8
2.2 Connection Diagram of Test System.....9
2.3 Support Unit used in test configuration and system9
2.4 Measurement Results Explanation Example.....9
2.5 Frequency List of Low/Middle/High Channels10
3 Conducted Test Items.....12
3.1 Measuring Instruments12
3.2 Conducted Output Power Measurement13
3.3 Peak-to-Average Ratio14
3.4 EIRP15
3.5 Occupied Bandwidth.....16
3.6 Conducted Band Edge17
3.7 Conducted Spurious Emission18
3.8 Frequency Stability19
4 Radiated Test Items20
4.1 Measuring Instruments20
4.2 Test Setup20
4.3 Test Result of Radiated Test21
4.4 Radiated Spurious Emission22
5 List of Measuring Equipment.....23
6 Measurement Uncertainty25
Appendix A. Test Results of Conducted Test
Appendix B. Test Results of Radiated Test
Appendix C. Test Setup Photographs



History of this test report

Report No.	Version	Description	Issue Date
FG3D2703-02D	01	Initial issue of report	Aug. 07, 2024



Summary of Test Result

Report Clause	Ref Std. Clause	Test Items	Result (PASS/FAIL)	Remark
3.2	§2.1046	Conducted Output Power	Pass	-
3.3	§96.41	Peak-to-Average Ratio	Pass	-
3.4	§96.41	Effective Isotropic Radiated Power	Pass	-
3.5	§2.1049 §96.41	Occupied Bandwidth	Pass	-
3.6	§2.1051 §96.41	Conducted Band Edge Measurement	Pass	-
3.7	§2.1051 §96.41	Conducted Spurious Emission	Pass	-
3.8	§2.1055	Frequency Stability for Temperature & Voltage	Pass	-
4.4	§2.1053 §96.41	Radiated Spurious Emission	Pass	4.29 dB under the limit at 10653.00 MHz

Conformity Assessment Condition:

1. The test results (PASS/FAIL) with all measurement uncertainty excluded are presented against the regulation limits or in accordance with the requirements stipulated by the applicant/manufacturer who shall bear all the risks of non-compliance that may potentially occur if measurement uncertainty is taken into account.
2. The measurement uncertainty please refer to each test result in the section "Measurement Uncertainty".

Disclaimer:

The product specifications of the EUT presented in the test report that may affect the test assessments are declared by the manufacturer who shall take full responsibility for the authenticity.

Reviewed by: Keven Cheng

Report Producer: Rebecca Wu



1 General Description

1.1 Product Feature of Equipment Under Test

Product Feature	
General Specs	
WCDMA/LTE/5G NR and GNSS.	

Support band and evaluated information	
Supported band	B48, B48C
Evaluated and Tested band	B48, B48C

TDD band Power Class		
	SISO PC3	SISO PC2
B48/ B48C	V	-

RF Exposure					
Max Antenna Gain information(dBi)					
Band	Ant 0	Ant 1	Ant 2	Ant 3	Main Ant. #
B48	0.2	0.2	0.2	0.2	2

Remark: The EUT's information above is declared by manufacturer. Please refer to Disclaimer in report summary.

1.2 Modification of EUT

No modifications made to the EUT during the testing.



1.3 Testing Site

Test Site	Sporton International Inc. EMC & Wireless Communications Laboratory
Test Site Location	No.52, Huaya 1st Rd., Guishan Dist., Taoyuan City 333, Taiwan (R.O.C.) TEL: +886-3-327-3456 FAX: +886-3-328-4978
Test Site No.	Sporton Site No. TH03-HY
Test Engineer	HaoEn Zhang
Temperature (°C)	22.3~23.8
Relative Humidity (%)	50.6~55.1

Test Site	Sporton International Inc. Wensan Laboratory
Test Site Location	No.58, Aly. 75, Ln. 564, Wenhua 3rd, Rd., Guishan Dist., Taoyuan City 333010, Taiwan (R.O.C.) TEL: +886-3-327-0868 FAX: +886-3-327-0855
Test Site No.	Sporton Site No. 03CH12-HY (TAF Code: 3786)
Test Engineer	Jesse Fan, Tim Lee, and Wilson Wu
Temperature (°C)	20~25
Relative Humidity (%)	50~60
Remark	The Radiated Spurious Emission test item subcontracted to Sporton International Inc. Wensan Laboratory.

Note: The test site complies with ANSI C63.4 2014 requirement.

FCC Designation No.: TW1190 and TW3786



1.4 Applied Standards

According to the specifications declared by the manufacturer, the EUT must comply with the requirements of the following standards:

- ♦ ANSI C63.26-2015
- ♦ ANSI / TIA-603-E
- ♦ FCC 47 CFR Part 2, 96
- ♦ FCC KDB 971168 D01 Power Meas. License Digital Systems v03r01
- ♦ FCC KDB 940660 D01 Part 96 CBRS Eqpt v03
- ♦ FCC KDB 412172 D01 Determining ERP and EIRP v01r01
- ♦ FCC KDB 414788 D01 Radiated Test Site v01r01

Remark:

1. All the test items were validated and recorded in accordance with the standards without any modification during the testing.
2. This EUT has also been tested and complied with the requirements of FCC Part 15, Subpart B, recorded in a separate test report.
3. The TAF code is not including all the FCC KDB listed without accreditation.



2 Test Configuration of Equipment Under Test

2.1 Test Mode

Antenna port conducted and radiated test items listed below are performed according to KDB 971168 D01 Power Meas. License Digital Systems v03r01 with maximum output power.

For radiated measurement, the measured emission level of the EUT was maximized by rotating the EUT on a turntable, adjusting the orientation of the EUT and EUT antenna in three orthogonal axis (X: flat, Y: portrait, Z: landscape), and adjusting the measurement antenna orientation, following C63.26 exploratory test procedures and only the worst case emissions were reported in this report.

Modulation Type	Modulation
A	QPSK
B	16QAM
C	64QAM
D	256QAM

Test Item	Modulation Type	Bandwidth	RB Size	Channel
Conducted Power	A, B, C, D	All	1, Half, Full	L, M, H
EIRP	A, B, C, D	All	1, Half, Full	L, M, H
PAR	A, B, C, D	20 MHz	Full	M
Bandwidth	A, B, C, D	All	Full	M
ACLR, Mask	A, B, C, D	All	1RB Full	L, M, H
CSE	A	All	1RB	L, M, H
Frequency Stability	A	10 MHz	Full	M
RSE	A	20 MHz	1RB	L, M, H

Remark:

1. Evaluated all the transmitter signal and reporting worst-case configuration among all modulation types.
2. The device is investigated from 30MHz to 10 times of fundamental signal for radiated spurious emission test under different RB size/offset and modulations in exploratory test. Subsequently, only the worst-case emissions are reported.
3. One representative bandwidth is selected to perform PAR and frequency stability.
4. For LTE B48 support Antenna 2 (Main Ant.) and Antenna 0&1&3; Radiated Spurious Emission is full test. Conducted test items are verified and the worst case is Antenna 2. Therefore, the report only performed Antenna 2 test results.
5. The test country code is set to MCC 310.

2.2 Connection Diagram of Test System

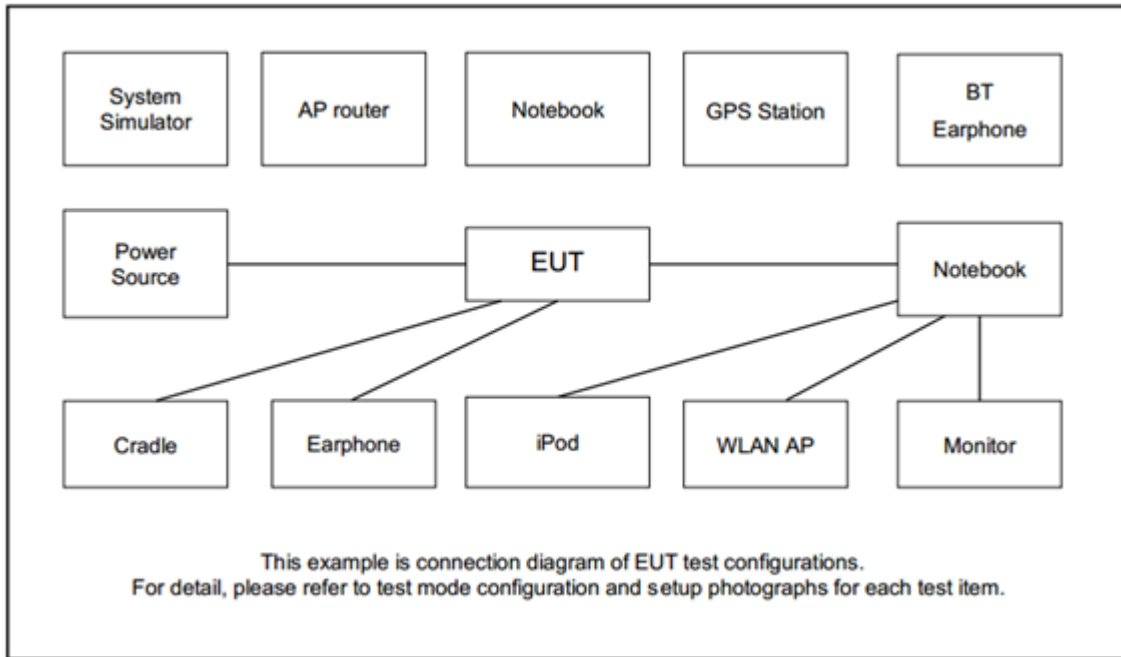

2.3 Support Unit used in test configuration and system

Item	Equipment	Brand Name	Model No.	FCC ID	Data Cable	Power Cord
1.	Carrier board	Qualcomm	30-35174-500	N/A	N/A	N/A
2.	System Simulator	Anritsu	MT8821C	N/A	N/A	Unshielded, 1.8 m
3.	System Simulator	Anritsu	MT8000A	N/A	N/A	Unshielded, 1.8 m

2.4 Measurement Results Explanation Example

For all conducted test items:

The offset level is set in the spectrum analyzer to compensate the RF cable loss and attenuator factor between EUT conducted output port and spectrum analyzer. With the offset compensation, the spectrum analyzer reading level is exactly the EUT RF output level.

The spectrum analyzer offset is derived from RF cable loss and attenuator factor.

Offset = RF cable loss + attenuator factor.

Following shows an offset computation example with cable loss 4.5 dB and 10dB attenuator.

Example :

$$\begin{aligned} \text{Offset(dB)} &= \text{RF cable loss(dB)} + \text{attenuator factor(dB)}. \\ &= 4.5 + 10 = 14.5 \text{ (dB)} \end{aligned}$$



2.5 Frequency List of Low/Middle/High Channels

LTE Band 48 Channel and Frequency List				
BW [MHz]	Channel/Frequency(MHz)	Lowest	Middle	Highest
20	Channel	55340	55990	56640
	Frequency	3560	3625	3690
15	Channel	55315	55990	56665
	Frequency	3557.5	3625	3692.5
10	Channel	55290	55990	56690
	Frequency	3555	3625	3695
5	Channel	55265	55990	56715
	Frequency	3552.5	3625	3697.5



LTE Band 48C Channel and Frequency List_CA					
BW [MHz]	Channel/Frequency(MHz)		Lowest	Middle	Highest
20 + 20	PCC	Channel	55340	55891	56442
		Frequency	3560	3615.1	3670.2
	SCC	Channel	55538	56089	56640
		Frequency	3579.8	3634.9	3690.0
20 + 15	PCC	Channel	55340	55916	56491
		Frequency	3560	3617.6	3675.1
	SCC	Channel	55511	56087	56662
		Frequency	3577.1	3634.7	3692.2
15 + 20	PCC	Channel	55318	55893	56469
		Frequency	3557.8	3615.3	3672.9
	SCC	Channel	55489	56064	56640
		Frequency	3574.9	3632.4	3690.0
20 + 10	PCC	Channel	55340	55941	56541
		Frequency	3560	3620.1	3680.1
	SCC	Channel	55484	56085	56685
		Frequency	3574.4	3634.5	3694.5
10 + 20	PCC	Channel	55295	55896	56496
		Frequency	3555.5	3615.6	3675.6
	SCC	Channel	55439	56040	56640
		Frequency	3569.9	3630	3690
20 + 5	PCC	Channel	55340	55965	56590
		Frequency	3560	3622.5	3685
	SCC	Channel	55457	56082	56707
		Frequency	3571.7	3634.2	3696.7
5 + 20	PCC	Channel	55273	55896	56523
		Frequency	3553.3	3615.6	3678.3
	SCC	Channel	55390	56015	56640
		Frequency	3565	3627.5	3690.0

3 Conducted Test Items

3.1 Measuring Instruments

See list of measuring instruments of this test report.

3.1.1 Test Setup

3.1.2 Conducted Output Power

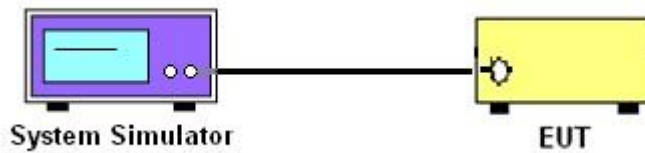

3.1.3 EIRP, Peak-to-Average Ratio, Occupied Bandwidth, Conducted Band-Edge, and Conducted Spurious Emission

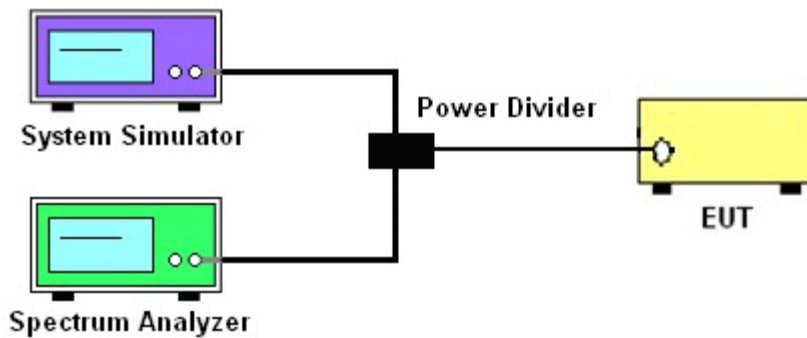

3.1.4 Frequency Stability

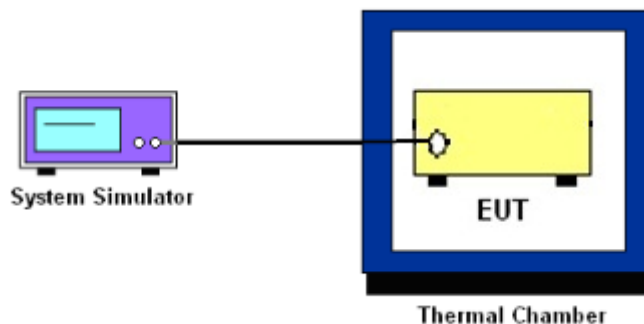

3.1.5 Test Result of Conducted Test

Please refer to Appendix A.



3.2 Conducted Output Power Measurement

3.2.1 Description of the Conducted Output Power Measurement

A base station simulator was used to establish communication with the EUT. Its parameters were set to transmit the maximum power on the EUT. The measured power in the radio frequency on the transmitter output terminals shall be reported.

3.2.2 Test Procedures

1. The transmitter output port was connected to base station.
2. Set EUT at maximum power through base station.
3. Select lowest, middle, and highest channels for each band and different modulation.
4. Measure and record the power level from the system simulator.



3.3 Peak-to-Average Ratio

3.3.1 Description of the PAR Measurement

Power Complementary Cumulative Distribution Function (CCDF) curves provide a means for characterizing the power peaks of a digitally modulated signal on a statistical basis. A CCDF curve depicts the probability of the peak signal amplitude exceeding the average power level. Most contemporary measurement instrumentation include the capability to produce CCDF curves for an input signal provided that the instrument's resolution bandwidth can be set wide enough to accommodate the entire input signal bandwidth. In measuring transmissions in this band using an average power technique, the peak-to-average ratio (PAR) of the transmission may not exceed 13 dB.

3.3.2 Test Procedures

The testing follows ANSI C63.26-2015 Section 5.2.6

1. The EUT was connected to spectrum and system simulator via a power divider.
2. Set the CCDF (Complementary Cumulative Distribution Function) option in spectrum analyzer.
3. The highest RF powers were measured and recorded the maximum PAPR level associated with a probability of 0.1 %.
4. Record the deviation as Peak to Average Ratio.



3.4 EIRP

3.4.1 Description of the EIRP Measurement

The EIRP of mobile transmitters must not exceed 23 dBm /10 megahertz for LTE Band 48.

The testing follows ANSI C63.26-2015 Section 5.2.5.5.

According to KDB 412172 D01 Power Approach,

$EIRP = P_T + G_T - LC$, where

P_T = transmitter output power in dBm

G_T = gain of the transmitting antenna in dBi

LC = signal attenuation in the connecting cable between the transmitter and antenna in dB

Device	Maximum EIRP (dBm/10 MHz)	Maximum PSD (dBm/MHz)
End User Device	23	n/a

Remark: Total channel power is complied with EIRP limit 23dBm/10MHz.

3.4.2 Test Procedures

The testing follows procedure in Section 5.2 of ANSI C63.26-2015 and KDB 940660 D01 Part 96 CBRS Eqpt v03 Section 3.2(b)(2)

Determine the EIRP by adding the effective antenna gain to the measured average conducted power level.



3.5 Occupied Bandwidth

3.5.1 Description of Occupied Bandwidth Measurement

The occupied bandwidth is the width of a frequency band such that, below the lower and above the upper frequency limits, the mean powers emitted are each equal to a specified percentage 0.5% of the total mean transmitted power.

The 26 dB emission bandwidth is defined as the frequency range between two points, one above and one below the carrier frequency, at which the spectral density of the emission is attenuated 26 dB below the maximum in-band spectral density of the modulated signal. Spectral density (power per unit bandwidth) is to be measured with a detector of resolution bandwidth equal to approximately 1.0% of the emission bandwidth.

3.5.2 Test Procedures

The testing follows ANSI C63.26-2015 Section 5.4.3 (26dB) and Section 5.4.4 (99OB)

1. The EUT was connected to spectrum analyzer and system simulator via a power divider.
2. The spectrum analyzer center frequency is set to the nominal EUT channel center frequency. The span range for the spectrum analyzer shall be between two and five times the anticipated OBW.
3. The nominal resolution bandwidth (RBW) shall be in the range of 1 to 5 % of the anticipated OBW, and the VBW shall be at least 3 times the RBW.
4. Set the detection mode to peak, and the trace mode to max hold.
5. Determine the reference value: Set the EUT to transmit a modulated signal. Allow the trace to stabilize. Set the spectrum analyzer marker to the highest level of the displayed trace.
(this is the reference value)
6. Determine the “-26 dB down amplitude” as equal to (Reference Value – X).
7. Place two markers, one at the lowest and the other at the highest frequency of the envelope of the spectral display such that each marker is at or slightly below the “-X dB down amplitude” determined in step 6. If a marker is below this “-X dB down amplitude” value it shall be placed as close as possible to this value. The OBW is the positive frequency difference between the two markers.
8. Use the 99 % power bandwidth function of the spectrum analyzer and report the measured bandwidth.



3.6 Conducted Band Edge

3.6.1 Description of Conducted Band Edge Measurement

The conducted power of any End User Device emission outside the fundamental emission (whether in or outside of the authorized band) shall not exceed -13 dBm/MHz within 0 to B megahertz (where B is the bandwidth in megahertz of the assigned channel or multiple contiguous channels of the End User Device) above the upper CBSD-assigned channel edge and within 0 to B megahertz below the lower CBSD-assigned channel edge. At all frequencies greater than B megahertz above the upper CBSD assigned channel edge and less than B megahertz below the lower CBSD-assigned channel edge, the conducted power of any End User Device emission shall not exceed -25 dBm/MHz. Notwithstanding the emission limits in this paragraph, the Adjacent Channel Leakage Ratio for End User Devices shall be at least 30 dB.

3.6.2 Test Procedures

The testing follows FCC KDB 971168 D01 v03r01 Section 6.1.

1. The EUT was connected to spectrum analyzer and system simulator via a power divider.
2. The band edges of low and high channels for the highest RF powers were measured.
3. Set RBW $\geq 1\%$ EBW in the 1MHz band immediately outside and adjacent to the band edge.
4. Beyond the 1 MHz band from the band edge, RBW=1MHz was used
5. Set spectrum analyzer with RMS detector.
6. The RF fundamental frequency should be excluded against the limit line in the operating frequency band.

For Adjacent Channel Leakage Ratio (ACLR) measurement,

1. The Adjacent Channel Leakage Ratio (ACLR) is the ratio of the average power in the assigned aggregated channel bandwidth to the average power over the equivalent adjacent channel bandwidth.
2. The option ACLR of spectrum analyzer is used and measures the ACLR ratio by setting equivalent channel bandwidth.
3. The measured ACLR ratio shall be at least 30 dB.



3.7 Conducted Spurious Emission

3.7.1 Description of Conducted Spurious Emission Measurement

96.41 (e)(2)

The conducted power of any emissions below 3530 MHz or above 3720 MHz shall not exceed -40dBm/MHz.

3.7.2 Test Procedures

The testing follows FCC KDB 971168 D01 v03r01 Section 6.1.

1. The EUT was connected to spectrum analyzer and system simulator via a power divider.
2. The RF output of EUT was connected to the spectrum analyzer by RF cable and attenuator. The path loss was compensated to the results for each measurement.
3. The middle channel for the highest RF power within the transmitting frequency was measured.
4. The conducted spurious emission for the whole frequency range was taken.
5. Make the measurement with the spectrum analyzer's RBW = 1MHz, VBW = 3MHz.
6. Set spectrum analyzer with RMS detector.
7. Taking the record of maximum spurious emission.
8. The RF fundamental frequency should be excluded against the limit line in the operating frequency band.
9. The limit line is -40dBm/MHz.



3.8 Frequency Stability

3.8.1 Description of Frequency Stability Measurement

The frequency stability shall be measured by variation of ambient temperature and variation of primary supply voltage to ensure that the fundamental emission stays within the authorized frequency block.

3.8.2 Test Procedures for Temperature Variation

The testing follows FCC KDB 971168 D01 v03r01 Section 9.0.

1. The EUT was set up in the thermal chamber and connected with the system simulator.
2. With power OFF, the temperature was decreased to -30°C and the EUT was stabilized before testing. Power was applied and the maximum change in frequency was recorded within one minute.
3. With power OFF, the temperature was raised in 10°C step up to 50°C . The EUT was stabilized at each step for at least half an hour. Power was applied and the maximum frequency change was recorded within one minute.

3.8.3 Test Procedures for Voltage Variation

The testing follows FCC KDB 971168 D01 v03r01 Section 9.0.

1. The EUT was placed in a temperature chamber at $25\pm 5^{\circ}\text{C}$ and connected with the system simulator.
2. The power supply voltage to the EUT was varied from 85% to 115% of the nominal value measured at the input to the EUT.
3. The variation in frequency was measured for the worst case.

4 Radiated Test Items

4.1 Measuring Instruments

See list of measuring instruments of this test report.

4.2 Test Setup

For radiated test below 30MHz



For radiated test from 30MHz to 1GHz

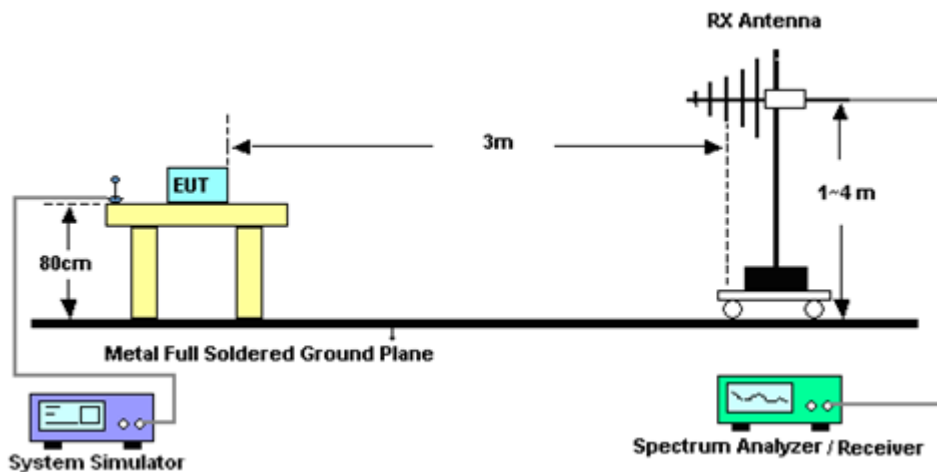

For radiated emissions from 1GHz to 18GHz

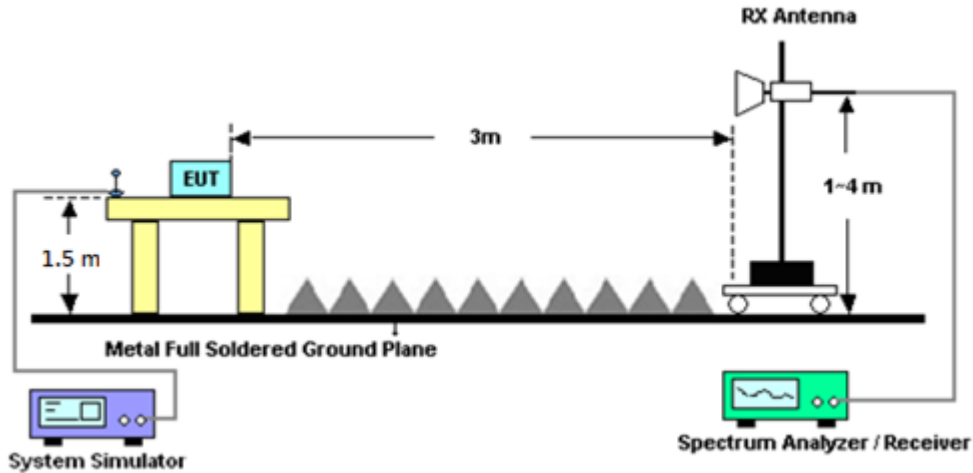

For radiated emissions above 18GHz

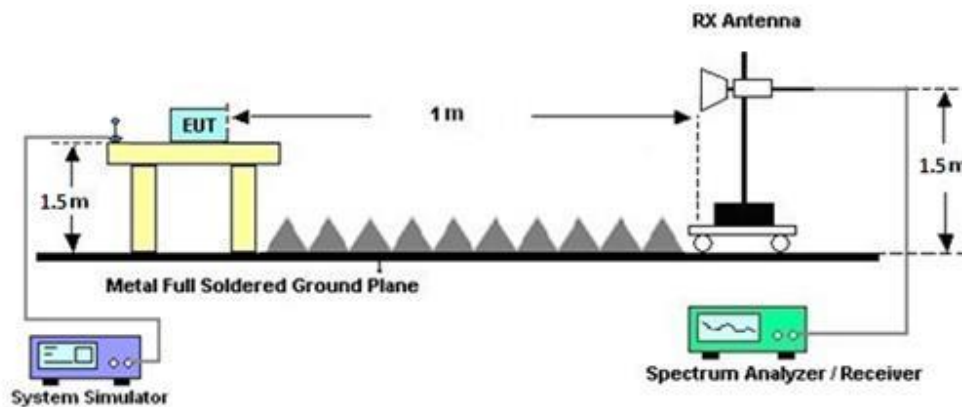

4.3 Test Result of Radiated Test

Please refer to Appendix B.

Note:

The low frequency, which started from 9 kHz to 30MHz, was pre-scanned and the result which was 20dB lower than the limit line was not reported.

There is adequate comparison measurement of both open-field test site and alternative test site - semi-Anechoic chamber according to 414788 D01 Radiated Test Site v01r01, and the result came out very similar.



4.4 Radiated Spurious Emission

4.4.1 Description of Radiated Spurious Emission

The radiated spurious emission was measured by substitution method according to ANSI / TIA-603-E. The power of any emission outside of the authorized operating frequency ranges must be attenuated below the transmitter power (P) by a factor of at least -40dBm / MHz

The spectrum is scanned from 30 MHz up to a frequency including its 10th harmonic.

4.4.2 Test Procedures

The testing follows FCC KDB 971168 D01 v03r01 Section 7 and ANSI C63.26-2015 section 5.5.4 Radiated measurement using the field strength method.

1. The EUT was placed on a turntable with 0.8 meter for frequency below 1GHz and 1.5 meter for frequency above 1GHz respectively above ground.
2. The EUT was set 3 meters from the receiving antenna mounted on the antenna tower.
3. The table was rotated 360 degrees to determine the position of the highest spurious emission.
4. The height of the receiving antenna is varied between 1m to 4m to search the maximum spurious emission for both horizontal and vertical polarizations.
5. During the measurement, the system simulator parameters were set to force the EUT transmitting at maximum output power.
6. To convert spectrum reading E(dBuV/m) to EIRP(dBm)
$$\text{EIRP(dBm)} = \text{Level (dBuV/m)} + 20\log(d) - 104.77,$$
where d is the distance at which field strength limit is specified in the rules
7. Field Strength Level (dBm) = Spectrum Reading (dBm) + Antenna Factor + Cable Loss + Read Level - Preamp Factor.
8. ERP (dBm) = EIRP (dBm) - 2.15
9. The RF fundamental frequency should be excluded against the limit line in the operating frequency band.



5 List of Measuring Equipment

Instrument	Brand Name	Model No.	Serial No.	Characteristics	Calibration Date	Test Date	Due Date	Remark
Loop Antenna	Rohde & Schwarz	HFH2-Z2	100315	9 kHz~30 MHz	Feb. 23, 2024	May 20, 2024~ Jul. 01, 2024	Feb. 22, 2025	Radiation (03CH12-HY)
Bilog Antenna	TESEQ	CBL 6111D & 00800N1D01N -06	37059 & 01	30MHz~1GHz	Nov. 03, 2023	May 20, 2024~ Jul. 01, 2024	Nov. 02, 2024	Radiation (03CH12-HY)
Horn Antenna	SCHWARZBE CK	BBHA 9120 D	9120D-02114	1GHz~18GHz	Jul. 31, 2023	May 20, 2024~ Jul. 01, 2024	Jul. 30, 2024	Radiation (03CH12-HY)
SHF-EHF Horn Antenna	SCHWARZBE CK	BBHA9170	00993	18GHz~40GHz	Nov. 24, 2023	May 20, 2024~ Jul. 01, 2024	Nov. 23, 2024	Radiation (03CH12-HY)
Preamplifier	COM-POWER	PA-103	161075	10MHz~1GHz	Mar. 20, 2024	May 20, 2024~ Jul. 01, 2024	Mar. 19, 2025	Radiation (03CH12-HY)
Preamplifier	Agilent	8449B	3008A02375	1GHz~26.5GHz	May 23, 2023	May 20, 2024~ May 21, 2024	May 22, 2024	Radiation (03CH12-HY)
Preamplifier	Agilent	8449B	3008A02375	1GHz~26.5GHz	May 22, 2024	May 22, 2024~ Jul. 01, 2024	May 21, 2025	Radiation (03CH12-HY)
Preamplifier	E-INSTRUME NT TECH LTD.	ERA-100M-18 G-56-01-A70	EC1900249	1GHz-18GHz	Dec. 20, 2023	May 20, 2024~ Jul. 01, 2024	Dec. 19, 2024	Radiation (03CH12-HY)
Preamplifier	EMEC	EM18G40G	060715	18GHz~40GHz	Dec. 07, 2023	May 20, 2024~ Jul. 01, 2024	Dec. 06, 2024	Radiation (03CH12-HY)
Spectrum Analyzer	Keysight	N9010A	MY54200485	10Hz~44GHz	May 13, 2024	May 20, 2024~ Jul. 01, 2024	May 12, 2025	Radiation (03CH12-HY)
EMI Test Receiver	Agilent	N9038A (MXE)	MY53290053	20Hz~26.5GHz	Aug. 29, 2023	May 20, 2024~ Jul. 01, 2024	Aug. 28, 2024	Radiation (03CH12-HY)
Filter	Wainwright	WHKX12-900- 1000-15000-60 SS	SN11	1GHz High Pass Filter	Mar. 13, 2024	May 20, 2024~ Jul. 01, 2024	Mar. 12, 2025	Radiation (03CH12-HY)
Filter	Wainwright	WHKX12-2700 -3000-18000-6 0SS	SN2	3GHz High Pass Filter	Mar. 13, 2024	May 20, 2024~ Jul. 01, 2024	Mar. 12, 2025	Radiation (03CH12-HY)
Filter	Wainwright	WHKX8-5872. 5-6750-18000- 40ST	SN2	6.75GHz High Pass Filter	Mar. 13, 2024	May 20, 2024~ Jul. 01, 2024	Mar. 12, 2025	Radiation (03CH12-HY)
RF Cable	HUBER + SUHNER	SUCOFLEX 102	803951/2	9kHz~30MHz	Mar. 06, 2024	May 20, 2024~ Jul. 01, 2024	Mar. 05, 2025	Radiation (03CH12-HY)
RF Cable	HUBER + SUHNER	SUCOFLEX 126E	0058/126E	30MHz~18GHz	Dec. 18, 2023	May 20, 2024~ Jul. 01, 2024	Dec. 17, 2024	Radiation (03CH12-HY)
RF Cable	HUBER + SUHNER	SUCOFLEX 102	505134/2	30MHz~40GHz	Dec. 18, 2023	May 20, 2024~ Jul. 01, 2024	Dec. 17, 2024	Radiation (03CH12-HY)
RF Cable	HUBER + SUHNER	SUCOFLEX 102	803953/2	30MHz~40GHz	Dec. 18, 2023	May 20, 2024~ Jul. 01, 2024	Dec. 17, 2024	Radiation (03CH12-HY)
Hygrometer	TECPEL	DTM-303B	TP210117	N/A	Oct. 19, 2023	May 20, 2024~ Jul. 01, 2024	Oct. 18, 2024	Radiation (03CH12-HY)
Controller	EMEC	EM1000	N/A	Control Turn table & Ant Mast	N/A	May 20, 2024~ Jul. 01, 2024	N/A	Radiation (03CH12-HY)
Antenna Mast	EMEC	AM-BS-4500-B	N/A	1m~4m	N/A	May 20, 2024~ Jul. 01, 2024	N/A	Radiation (03CH12-HY)
Turn Table	EMEC	TT2000	N/A	0~360 Degree	N/A	May 20, 2024~ Jul. 01, 2024	N/A	Radiation (03CH12-HY)
Software	Audix	E3 6.2009-8-24	RK-000989	N/A	N/A	May 20, 2024~ Jul. 01, 2024	N/A	Radiation (03CH12-HY)



Instrument	Brand Name	Model No.	Serial No.	Characteristics	Calibration Date	Test Date	Due Date	Remark
Radio Communication Analyzer	Anritsu	MT8821C	6262025353	LTE FDD/TDD LTE-2CC DLCA/ULCA	Oct. 03, 2023	Apr. 10, 2024~ Jul. 27, 2024	Oct. 02, 2024	Conducted (TH03-HY)
Thermal Chamber	ESPEC	SH-641	92013720	-40°C ~90°C	Sep. 04, 2023	Apr. 10, 2024~ Jul. 27, 2024	Sep. 03, 2024	Conducted (TH03-HY)
DC Power Supply	GW Instek	GPP-2323	GES906037	0V~64V ; 0A~6A	Nov. 28, 2023	Apr. 10, 2024~ Jul. 27, 2024	Nov. 27, 2024	Conducted (TH03-HY)
Coupler+10dB+ RFcable	Warison + WoKen + E-Instument	20dB 25W SMA Directional Coupler+ 10dB 18GHz_5W+ SFL405_1.5M	#A+#1+#1+#7	1-18GHz	Jan. 02, 2024	Apr. 10, 2024~ Jul. 27, 2024	Jan. 01, 2025	Conducted (TH03-HY)
Power divider	Anritsu	K241C	2143398	9KHz~40GHz	Jun. 13, 2023	Apr. 10, 2024~ Jun. 11, 2024	Jun. 12, 2024	Conducted (TH03-HY)
Power divider	Anritsu	K241C	2143398	9KHz~40GHz	Jun. 13, 2024	Jun. 13, 2024~ Jul. 27, 2024	Jun. 12, 2025	Conducted (TH03-HY)
Spectrum Analyzer	Rohde & Schwarz	FSV40	101905	10Hz~40GHz	Jul. 14, 2023	Apr. 10, 2024~ Jul. 12, 2024	Jul. 13, 2024	Conducted (TH03-HY)
Spectrum Analyzer	Rohde & Schwarz	FSV40	101905	10Hz~40GHz	Jul. 11, 2024	Jul. 13, 2024~ Jul. 27, 2024	Jul. 10, 2025	Conducted (TH03-HY)
Software	Sporton	NCC PLMN10 Test Tools	N/A	Conducted Test Item	N/A	Apr. 10, 2024~ Jul. 27, 2024	N/A	Conducted (TH03-HY)
Software	Anritsu	Auto Test System	N/A	Conducted Test Item	N/A	Apr. 10, 2024~ Jul. 27, 2024	N/A	Conducted (TH03-HY)



6 Measurement Uncertainty

Uncertainty of Radiated Emission Measurement (30 MHz ~ 1000 MHz)

Measuring Uncertainty for a Level of Confidence of 95% ($U = 2Uc(y)$)	3.291 dB
---	----------

Uncertainty of Radiated Emission Measurement (1 GHz ~ 18 GHz)

Measuring Uncertainty for a Level of Confidence of 95% ($U = 2Uc(y)$)	3.630 dB
---	----------

Uncertainty of Radiated Emission Measurement (18 GHz ~ 40 GHz)

Measuring Uncertainty for a Level of Confidence of 95% ($U = 2Uc(y)$)	4.140 dB
---	----------



Appendix A. Test Results of Conducted Test

Conducted Output Power (Average power) and EIRP

LTE Band 48 Maximum Average Power [dBm] (GT - LC = 0.2 dB)								
BW [MHz]	RB Size	RB Offset	Mod	Lowest	Middle	Highest	EIRP (dBm)	EIRP (W)
20	1	0	QPSK	22.59	22.30	22.30	22.89	0.1945
20	1	49		22.69	22.24	22.40		
20	1	99		22.64	22.25	22.24		
20	50	0		21.69	21.34	21.40		
20	50	24		21.69	21.41	21.42		
20	50	50		21.57	21.38	21.51		
20	100	0		21.65	21.35	21.36		
20	1	0	16-QAM	21.75	21.87	21.69	22.07	0.1611
20	1	49		21.70	21.34	21.53		
20	1	99		21.59	21.61	21.61		
20	50	0		20.61	20.40	20.46		
20	50	24		20.71	20.49	20.52		
20	50	50		20.62	20.36	20.58		
20	100	0		20.70	20.34	20.44		
20	1	0	64-QAM	21.01	20.36	20.70	21.21	0.1321
20	1	49		20.69	20.68	20.53		
20	1	99		20.67	20.31	20.55		
20	50	0		19.53	19.50	19.35		
20	50	24		19.63	19.50	19.32		
20	50	50		19.65	19.40	19.47		
20	100	0		19.60	19.37	19.32		
20	1	0	256-QAM	17.75	17.65	17.60	18.17	0.0656
20	1	49		17.41	17.03	17.97		
20	1	99		17.32	17.32	17.51		
20	50	0		17.68	17.45	17.24		
20	50	24		17.68	17.44	17.46		
20	50	50		17.56	17.44	17.52		
20	100	0		17.56	17.34	17.47		
Limit	EIRP < 23dBm/10MHz			Result			Pass	

Total EIRP power is less than partial EIRP limit 23 dBm/10MHz.



LTE Band 48 Maximum Average Power [dBm] (GT - LC = 0.2 dB)								
BW [MHz]	RB Size	RB Offset	Mod	Lowest	Middle	Highest	EIRP (dBm)	EIRP (W)
15	1	0	QPSK	22.49	22.41	22.30	22.78	0.1897
15	1	37		22.49	22.30	22.22		
15	1	74		22.58	22.30	22.32		
15	36	0		21.58	21.31	21.24		
15	36	20		21.54	21.31	21.40		
15	36	39		21.59	21.45	21.45		
15	75	0		21.55	21.35	21.30		
15	1	0	16-QAM	21.57	21.68	21.24	22.28	0.1690
15	1	37		22.08	21.65	21.38		
15	1	74		21.79	21.40	22.07		
15	36	0		20.57	20.44	20.34		
15	36	20		20.55	20.38	20.38		
15	36	39		20.68	20.45	20.56		
15	75	0		20.50	20.42	20.39		
15	1	0	64-QAM	20.38	19.80	20.35	21.42	0.1387
15	1	37		20.81	20.86	20.28		
15	1	74		21.22	20.46	20.67		
15	36	0		19.60	19.32	19.39		
15	36	20		19.49	19.33	19.35		
15	36	39		19.63	19.38	19.41		
15	75	0		19.46	19.37	19.32		
15	1	0	256-QAM	17.80	17.62	17.50	18.00	0.0631
15	1	37		17.78	17.37	17.65		
15	1	74		17.77	17.42	17.48		
15	36	0		17.60	17.37	17.32		
15	36	20		17.57	17.48	17.43		
15	36	39		17.51	17.52	17.55		
15	75	0		17.51	17.45	17.36		
Limit	EIRP < 23dBm/10MHz			Result			Pass	

Total EIRP power is less than partial EIRP limit 23 dBm/10MHz.



LTE Band 48 Maximum Average Power [dBm] (GT - LC = 0.2 dB)								
BW [MHz]	RB Size	RB Offset	Mod	Lowest	Middle	Highest	EIRP (dBm)	EIRP (W)
10	1	0	QPSK	22.58	22.32	22.33	22.92	0.1959
10	1	25		22.57	22.47	22.41		
10	1	49		22.72	22.23	22.31		
10	25	0		21.60	21.37	21.49		
10	25	12		21.62	21.53	21.48		
10	25	25		21.57	21.42	21.44		
10	50	0		21.62	21.42	21.44		
10	1	0	16-QAM	21.74	21.41	21.80	22.31	0.1702
10	1	25		22.11	21.97	21.65		
10	1	49		21.93	21.81	22.05		
10	25	0		20.57	20.49	20.41		
10	25	12		20.69	20.43	20.51		
10	25	25		20.67	20.37	20.54		
10	50	0		20.64	20.47	20.40		
10	1	0	64-QAM	20.54	20.76	20.64	21.21	0.1321
10	1	25		21.01	20.92	20.61		
10	1	49		20.53	20.35	20.66		
10	25	0		19.69	19.43	19.38		
10	25	12		19.64	19.48	19.44		
10	25	25		19.54	19.35	19.54		
10	50	0		19.64	19.55	19.51		
10	1	0	256-QAM	17.66	17.98	17.43	18.26	0.0670
10	1	25		17.47	17.48	17.85		
10	1	49		17.23	17.40	18.06		
10	25	0		17.63	17.60	17.54		
10	25	12		17.66	17.45	17.46		
10	25	25		17.60	17.49	17.54		
10	50	0		17.74	17.46	17.46		
Limit	EIRP < 23dBm/10MHz			Result			Pass	

Total EIRP power is less than partial EIRP limit 23 dBm/10MHz.



LTE Band 48 Maximum Average Power [dBm] (GT - LC = 0.2 dB)								
BW [MHz]	RB Size	RB Offset	Mod	Lowest	Middle	Highest	EIRP (dBm)	EIRP (W)
5	1	0	QPSK	22.66	22.48	22.45	22.86	0.1932
5	1	12		22.64	22.26	22.48		
5	1	24		22.60	22.36	22.26		
5	12	0		21.62	21.39	21.43		
5	12	7		21.65	21.46	21.46		
5	12	13		21.57	21.42	21.42		
5	25	0		21.64	21.45	21.40		
5	1	0	16-QAM	21.65	21.46	21.21	22.18	0.1652
5	1	12		21.74	21.75	21.62		
5	1	24		21.98	21.78	21.97		
5	12	0		20.69	20.41	20.44		
5	12	7		20.67	20.60	20.57		
5	12	13		20.64	20.39	20.42		
5	25	0		20.66	20.44	20.45		
5	1	0	64-QAM	20.82	20.41	20.74	21.25	0.1334
5	1	12		20.96	21.05	20.46		
5	1	24		20.76	20.63	20.44		
5	12	0		19.71	19.52	19.49		
5	12	7		19.67	19.50	19.58		
5	12	13		19.71	19.33	19.51		
5	25	0		19.70	19.45	19.47		
5	1	0	256-QAM	17.87	17.78	17.75	18.07	0.0641
5	1	12		17.82	17.55	17.80		
5	1	24		17.54	17.49	17.00		
5	12	0		17.60	17.47	17.48		
5	12	7		17.63	17.48	17.52		
5	12	13		17.79	17.45	17.27		
5	25	0		17.69	17.54	17.50		
Limit	EIRP < 23dBm/10MHz			Result			Pass	

Total EIRP power is less than partial EIRP limit 23 dBm/10MHz.



LTE Band 48C_CA Maximum Average Power [dBm] (GT - LC = 0.2 dB)										
BW [MHz]	PCC		SCC		Mod	Lowest	Middle	Highest	EIRP (dBm)	EIRP (W)
	RB Size	RB Offset	RB Size	RB Offset						
20+20	100	0	100	0	QPSK	12.37	18.73	12.24	21.71	0.1483
20+20	1	0	1	99		5.31	11.74	5.08		
20+20	1	99	1	0		18.23	21.51	18.11		
20+20	100	0	100	0	16-QAM	12.45	18.75	12.26	22.43	0.1750
20+20	1	0	1	99		5.82	12.29	5.65		
20+20	1	99	1	0		18.89	22.23	18.81		
20+20	100	0	100	0	64-QAM	12.43	18.78	12.28	20.59	0.1146
20+20	1	0	1	99		5.78	12.24	5.62		
20+20	1	99	1	0		19.10	20.39	19.11		
20+20	100	0	100	0	256-QAM	12.40	18.25	12.29	18.68	0.0738
20+20	1	0	1	99		5.58	12.12	5.45		
20+20	1	99	1	0		18.48	18.27	18.34		
20+15	100	0	75	0	QPSK	12.39	18.70	12.24	21.71	0.1483
20+15	1	0	1	74		5.37	11.72	5.21		
20+15	1	74	1	0		16.95	21.51	16.86		
20+15	100	0	75	0	16-QAM	12.44	18.74	12.27	22.41	0.1742
20+15	1	0	1	74		5.86	12.29	5.57		
20+15	1	74	1	0		17.40	22.21	17.36		
20+15	100	0	75	0	64-QAM	12.37	18.77	12.25	20.68	0.1169
20+15	1	0	1	74		5.82	12.25	5.66		
20+15	1	74	1	0		17.58	20.48	17.60		
20+15	100	0	75	0	256-QAM	12.38	18.23	12.24	18.54	0.0714
20+15	1	0	1	74		5.57	12.11	5.48		
20+15	1	74	1	0		17.42	18.34	17.33		
15+20	75	0	100	0	QPSK	12.41	18.81	12.23	21.79	0.1510
15+20	1	0	1	99		5.34	11.76	5.20		
15+20	1	74	1	0		16.99	21.59	16.95		
15+20	75	0	100	0	16-QAM	12.44	18.76	12.29	22.50	0.1778
15+20	1	0	1	99		5.82	12.24	5.72		
15+20	1	74	1	0		17.48	22.30	17.35		
15+20	75	0	100	0	64-QAM	12.43	18.82	12.29	20.69	0.1172
15+20	1	0	1	99		5.74	12.25	5.65		
15+20	1	74	1	0		17.78	20.49	17.53		
15+20	75	0	100	0	256-QAM	12.41	18.28	12.32	18.57	0.0719
15+20	1	0	1	99		5.63	11.97	5.50		
15+20	1	74	1	0		17.50	18.37	17.43		
Limit	EIRP < 23dBm/10MHz					Result			Pass	

Total EIRP power is less than partial EIRP limit 23 dBm/10MHz.



LTE Band 48C_CA Maximum Average Power [dBm] (GT - LC = 0.2 dB)										
BW [MHz]	PCC		SCC		Mod	Lowest	Middle	Highest	EIRP (dBm)	EIRP (W)
	RB Size	RB Offset	RB Size	RB Offset						
20+10	100	0	50	0	QPSK	12.42	18.73	12.28	21.29	0.1346
20+10	1	0	1	49		5.39	11.77	5.24		
20+10	1	99	1	0		17.01	21.09	16.90		
20+10	100	0	50	0	16-QAM	12.46	18.75	12.29	21.98	0.1578
20+10	1	0	1	49		5.89	12.28	5.74		
20+10	1	99	1	0		17.51	21.78	17.36		
20+10	100	0	50	0	64-QAM	12.41	18.74	12.29	20.71	0.1178
20+10	1	0	1	49		5.83	12.20	5.63		
20+10	1	99	1	0		17.73	20.51	17.54		
20+10	100	0	50	0	256-QAM	12.45	18.22	12.28	18.52	0.0711
20+10	1	0	1	49		5.65	12.12	5.54		
20+10	1	99	1	0		17.47	18.32	17.42		
10+20	50	0	100	0	QPSK	12.41	18.77	12.25	21.47	0.1403
10+20	1	0	1	99		5.39	11.80	5.27		
10+20	1	49	1	0		17.12	21.27	17.01		
10+20	50	0	100	0	16-QAM	12.44	18.80	12.35	22.16	0.1644
10+20	1	0	1	99		5.84	12.24	5.76		
10+20	1	49	1	0		17.53	21.96	17.52		
10+20	50	0	100	0	64-QAM	12.44	18.78	12.29	20.81	0.1205
10+20	1	0	1	99		5.79	12.20	5.70		
10+20	1	49	1	0		17.73	20.61	17.66		
10+20	50	0	100	0	256-QAM	12.45	18.32	12.29	18.63	0.0729
10+20	1	0	1	99		5.62	12.12	5.52		
10+20	1	49	1	0		17.59	18.43	17.51		
20+5	100	0	25	0	QPSK	11.46	19.18	11.26	20.91	0.1233
20+5	1	0	1	24		5.40	11.81	5.21		
20+5	1	99	1	0		17.94	20.71	17.79		
20+5	100	0	25	0	16-QAM	11.48	19.19	11.26	21.63	0.1455
20+5	1	0	1	24		5.90	12.24	5.64		
20+5	1	99	1	0		18.58	21.43	18.45		
20+5	100	0	25	0	64-QAM	11.44	19.23	11.25	20.78	0.1197
20+5	1	0	1	24		5.86	12.20	5.66		
20+5	1	99	1	0		18.72	20.58	18.55		
20+5	100	0	25	0	256-QAM	11.46	18.23	11.25	18.78	0.0755
20+5	1	0	1	24		5.69	12.09	5.46		
20+5	1	99	1	0		18.58	18.41	18.48		
Limit	EIRP < 23dBm/10MHz					Result			Pass	

Total EIRP power is less than partial EIRP limit 23 dBm/10MHz.



LTE Band 48C_CA Maximum Average Power [dBm] (GT - LC = 0.2 dB)										
BW [MHz]	PCC		SCC		Mod	Lowest	Middle	Highest	EIRP (dBm)	EIRP (W)
	RB Size	RB Offset	RB Size	RB Offset						
5+20	25	0	100	0	QPSK	11.47	19.28	11.32	21.16	0.1306
5+20	1	0	1	99		5.36	11.76	5.22		
5+20	1	24	1	0		17.63	20.96	17.50		
5+20	25	0	100	0	16-QAM	11.50	19.30	11.33	21.74	0.1493
5+20	1	0	1	99		5.81	12.21	5.63		
5+20	1	24	1	0		18.28	21.54	18.13		
5+20	25	0	100	0	64-QAM	11.48	19.29	11.31	20.93	0.1239
5+20	1	0	1	99		5.78	12.19	5.62		
5+20	1	24	1	0		18.43	20.73	18.32		
5+20	25	0	100	0	256-QAM	11.49	18.32	11.33	18.73	0.0746
5+20	1	0	1	99		5.72	12.05	5.54		
5+20	1	24	1	0		18.18	18.53	18.07		
Limit	EIRP < 23dBm/10MHz					Result			Pass	

Total EIRP power is less than partial EIRP limit 23 dBm/10MHz.



LTE Band 48

Peak-to-Average Ratio

Mode	LTE Band 48 / 20MHz				
Mod.	QPSK	16QAM	64QAM	256QAM	Limit: 13dB
RB Size	Full RB	Full RB	Full RB	Full RB	Result
Middle CH	4.41	5.59	6.38	6.58	PASS



LTE Band 48 / 20MHz / QPSK

Middle Channel / Full RB

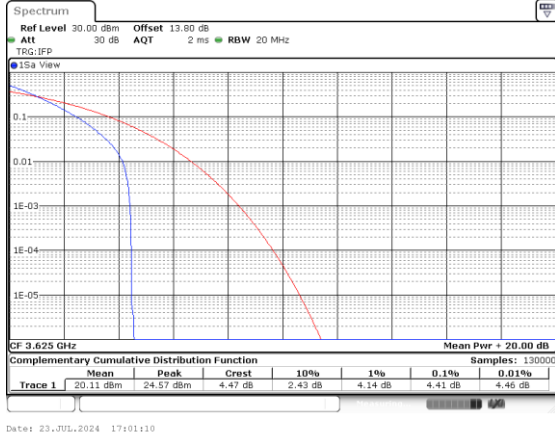

LTE Band 48 / 20MHz / 16QAM

Middle Channel / Full RB

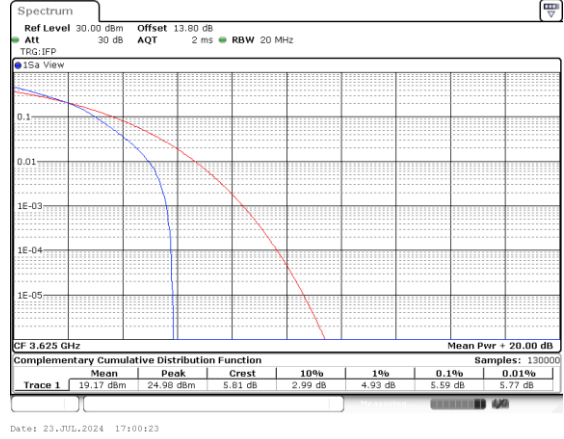

LTE Band 48 / 20MHz / 64QAM

Middle Channel / Full RB

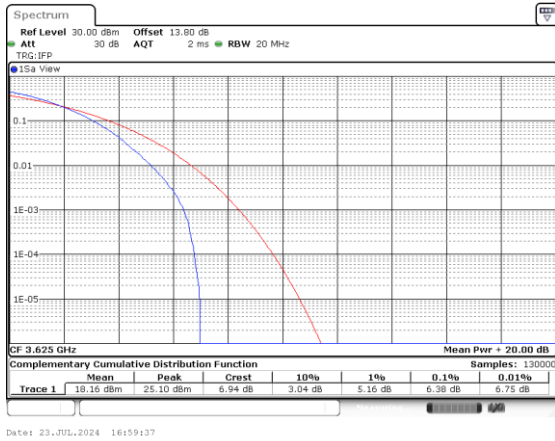

LTE Band 48 / 20MHz / 256QAM

Middle Channel / Full RB

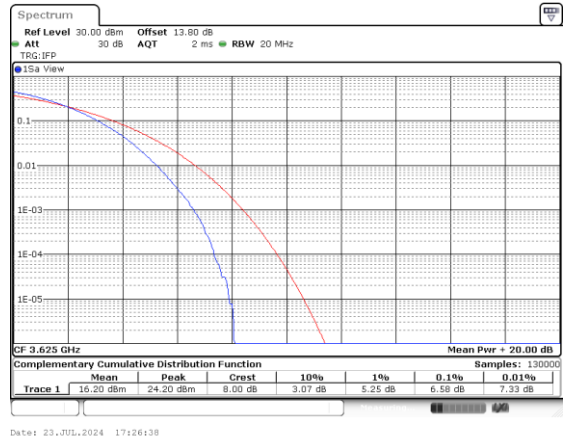



26dB Bandwidth

Mode	LTE Band 48 : 26dB BW(MHz)											
BW	1.4MHz		3MHz		5MHz		10MHz		15MHz		20MHz	
Mod.	QPSK	16QAM	QPSK	16QAM	QPSK	16QAM	QPSK	16QAM	QPSK	16QAM	QPSK	16QAM
Middle CH	-	-	-	-	4.89	5.09	9.65	9.83	14.35	14.41	19.14	18.78
Mode	LTE Band 48 : 26dB BW(MHz)											
BW	1.4MHz		3MHz		5MHz		10MHz		15MHz		20MHz	
Mod.	64QAM	256QAM	64QAM	256QAM	64QAM	256QAM	64QAM	256QAM	64QAM	256QAM	64QAM	256QAM
Middle CH	-	-	-	-	4.93	4.80	9.89	9.84	14.26	14.20	19.10	18.74



LTE Band 48

Middle Channel / 5MHz / QPSK

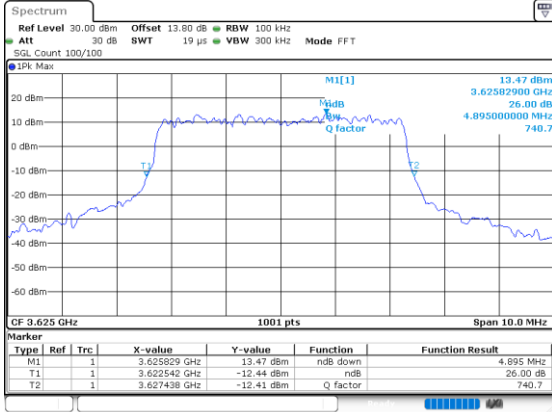

Date: 23-JUL-2024 16:18:03

Middle Channel / 5MHz / 16QAM

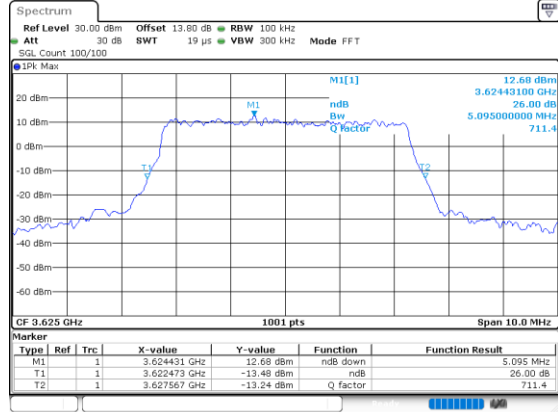

Date: 23-JUL-2024 16:18:43

Middle Channel / 10MHz / QPSK

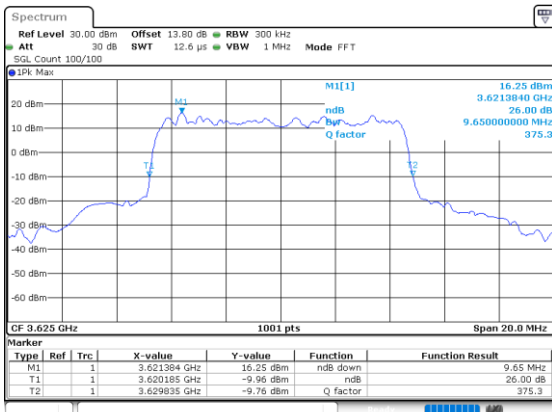

Date: 23-JUL-2024 16:31:13

Middle Channel / 10MHz / 16QAM

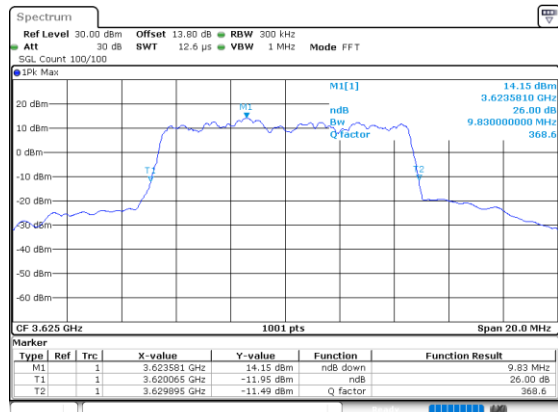

Date: 23-JUL-2024 16:31:58

Middle Channel / 15MHz / QPSK

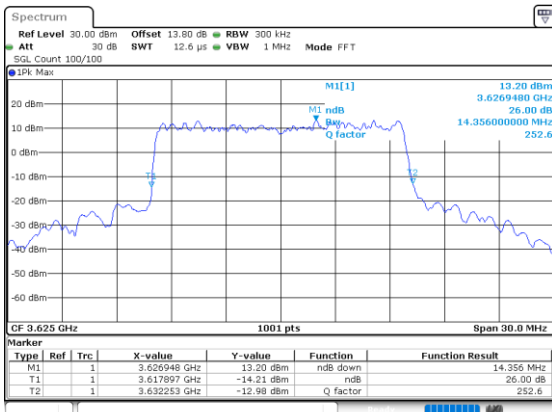

Date: 23-JUL-2024 16:43:59

Middle Channel / 15MHz / 16QAM

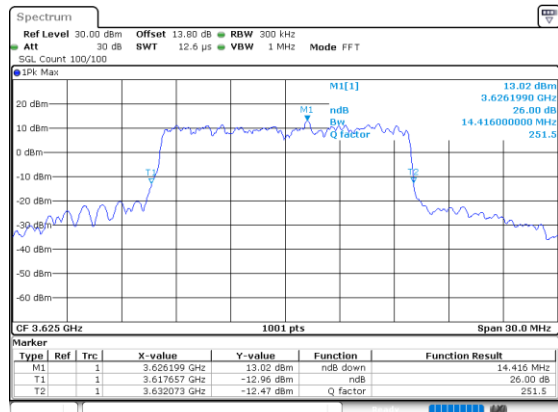

Date: 23-JUL-2024 16:44:41



LTE Band 48

Middle Channel / 20MHz / QPSK

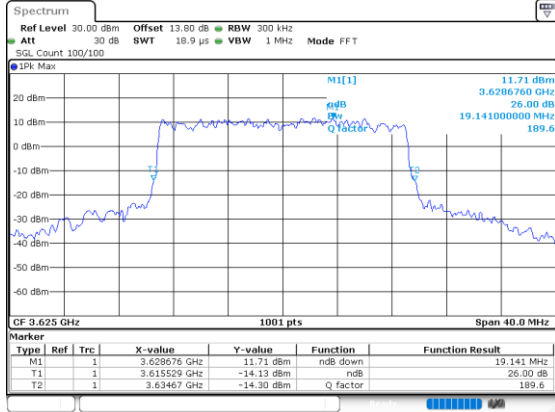

Date: 23-JUL-2024 16:57:17

Middle Channel / 20MHz / 16QAM

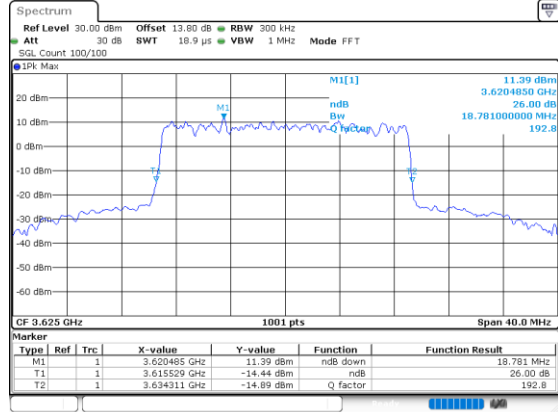

Date: 23-JUL-2024 16:57:57

Middle Channel / 5MHz / 64QAM

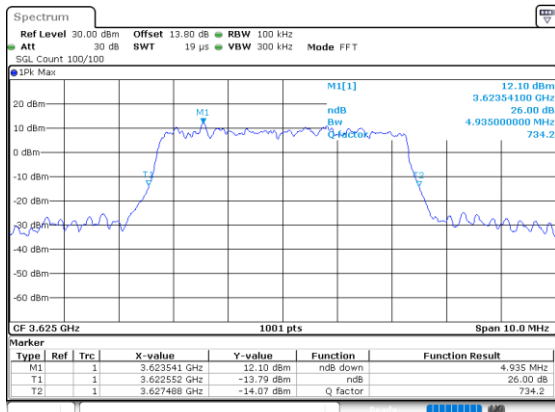

Date: 23-JUL-2024 16:19:49

Middle Channel / 10MHz / 64QAM

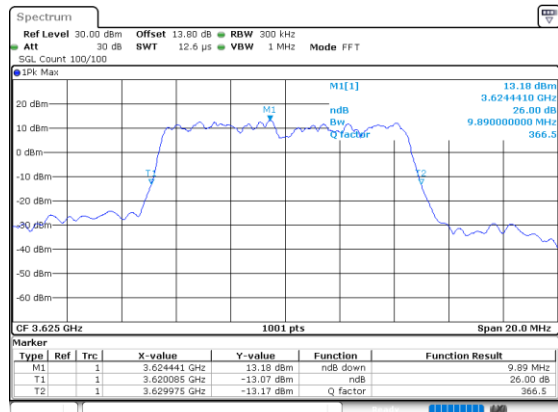

Date: 23-JUL-2024 16:13:05

Middle Channel / 15MHz / 64QAM

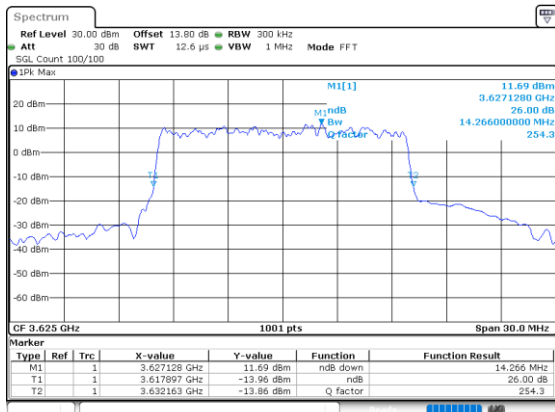

Date: 23-JUL-2024 16:45:51

Middle Channel / 20MHz / 64QAM

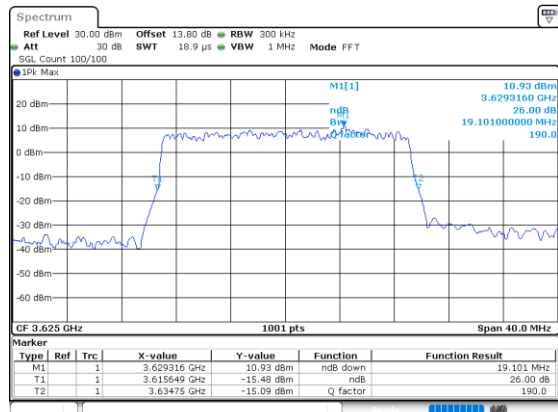

Date: 23-JUL-2024 16:59:10



LTE Band 48

Middle Channel / 5MHz / 256QAM

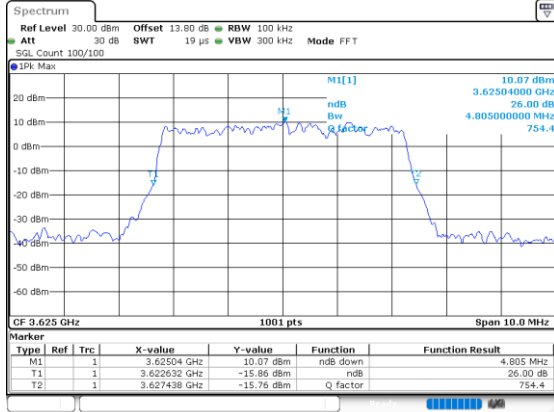

Date: 23-JUL-2024 17:11:58

Middle Channel / 10MHz / 256QAM

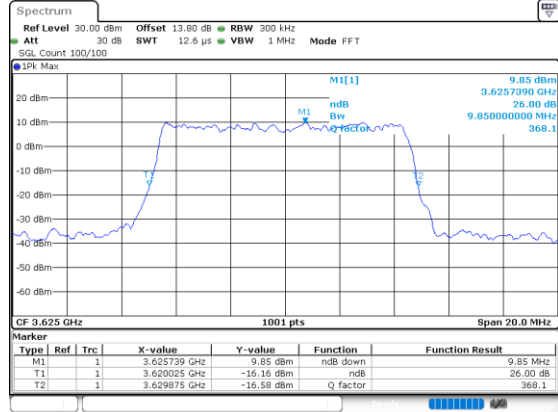

Date: 23-JUL-2024 17:16:17

Middle Channel / 15MHz / 256QAM

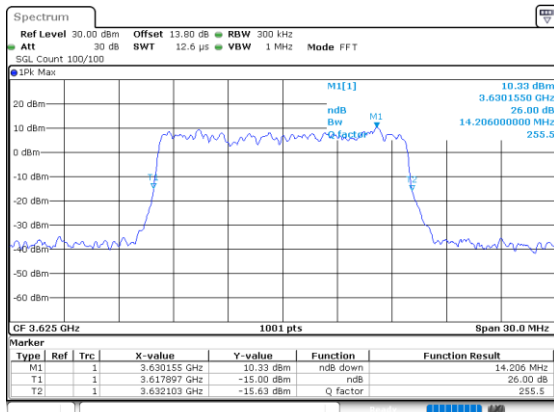

Date: 23-JUL-2024 17:20:34

Middle Channel / 20MHz / 256QAM

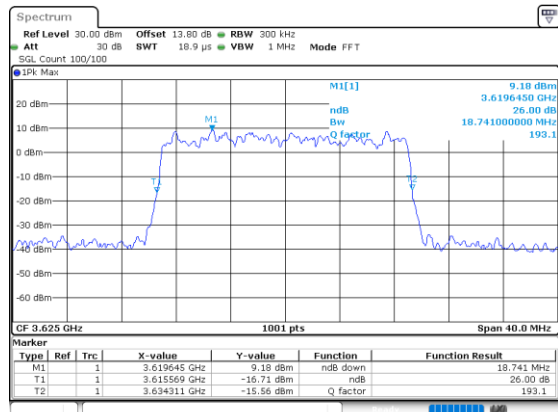

Date: 23-JUL-2024 17:24:48



Occupied Bandwidth

Mode	LTE Band 48 : 99%OBW(MHz)											
BW	1.4MHz		3MHz		5MHz		10MHz		15MHz		20MHz	
Mod.	QPSK	16QAM	QPSK	16QAM	QPSK	16QAM	QPSK	16QAM	QPSK	16QAM	QPSK	16QAM
Middle CH	-	-	-	-	4.46	4.48	9.05	9.00	13.44	13.43	17.94	17.84
Mode	LTE Band 48 : 99%OBW(MHz)											
BW	1.4MHz		3MHz		5MHz		10MHz		15MHz		20MHz	
Mod.	64QAM	256QAM	64QAM	256QAM	64QAM	256QAM	64QAM	256QAM	64QAM	256QAM	64QAM	256QAM
Middle CH	-	-	-	-	4.49	4.49	8.99	9.03	13.46	13.44	17.79	17.88



LTE Band 48

Middle Channel / 5MHz / QPSK

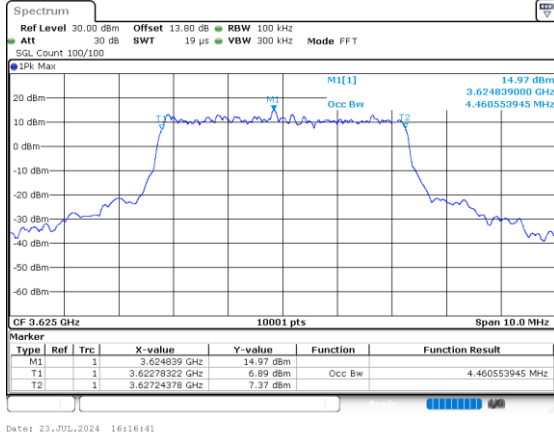

Middle Channel / 5MHz / 16QAM

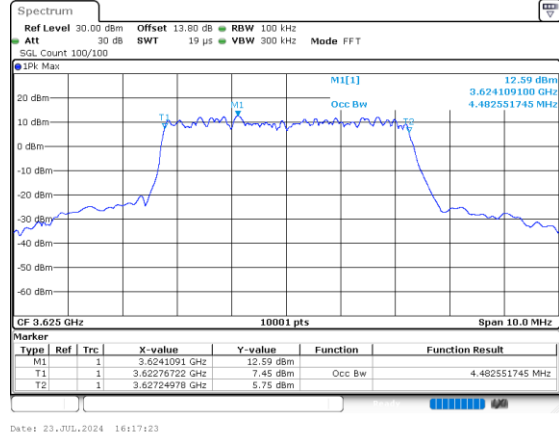

Middle Channel / 10MHz / QPSK

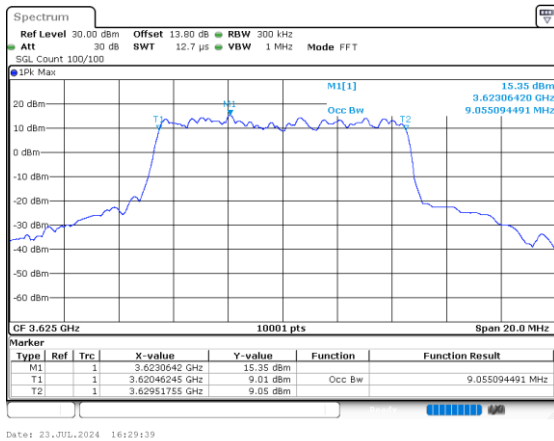

Middle Channel / 10MHz / 16QAM

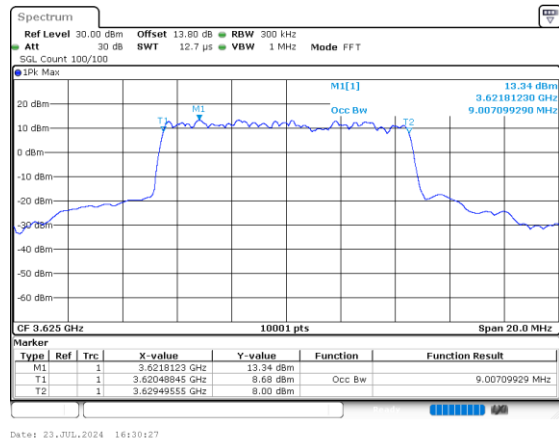

Middle Channel / 15MHz / QPSK

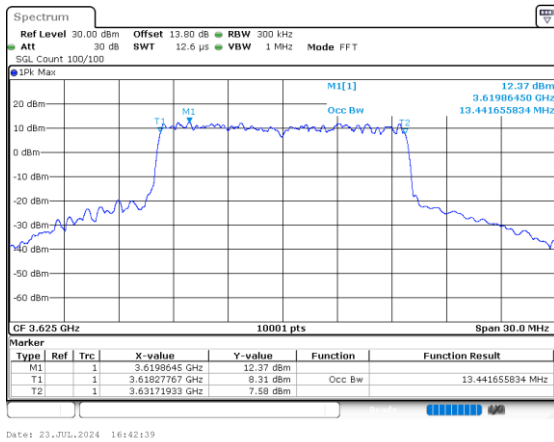

Middle Channel / 15MHz / 16QAM

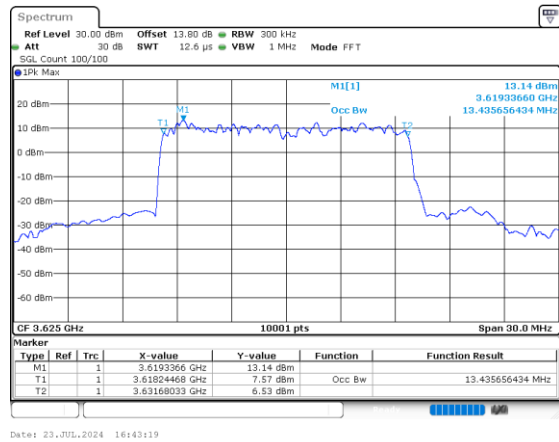



LTE Band 48

Middle Channel / 20MHz / QPSK

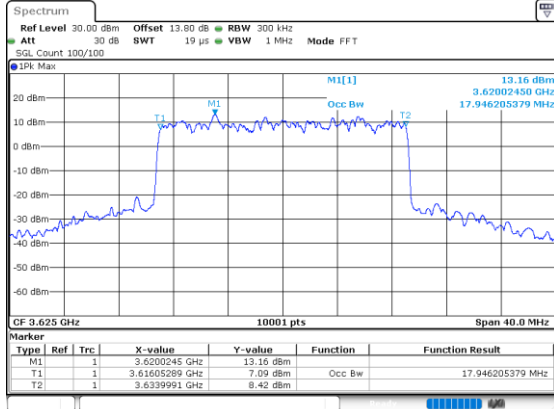

Date: 23.JUL.2024 16:55:49

Middle Channel / 20MHz / 16QAM

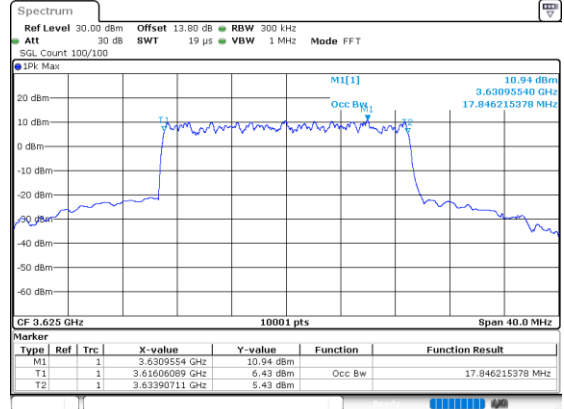

Date: 23.JUL.2024 16:56:36

Middle Channel / 5MHz / 64QAM

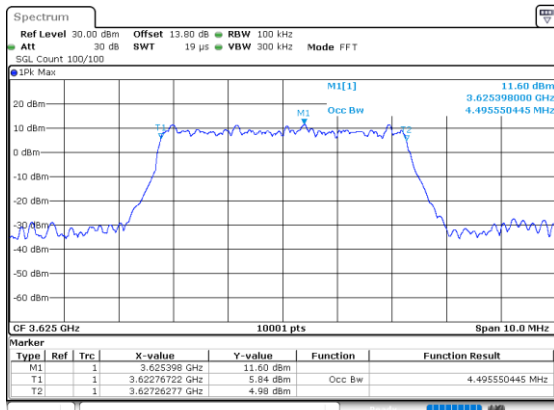

Date: 23.JUL.2024 16:19:24

Middle Channel / 10MHz / 64QAM

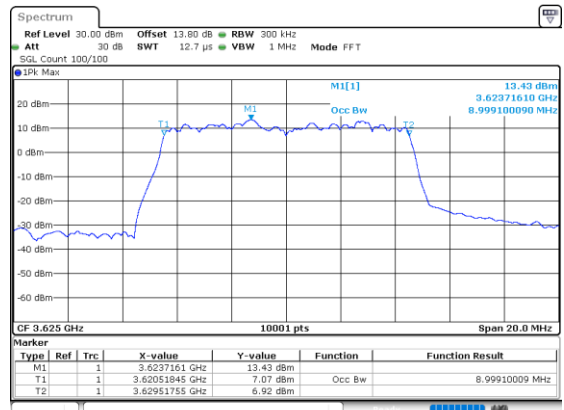

Date: 23.JUL.2024 16:32:39

Middle Channel / 15MHz / 64QAM

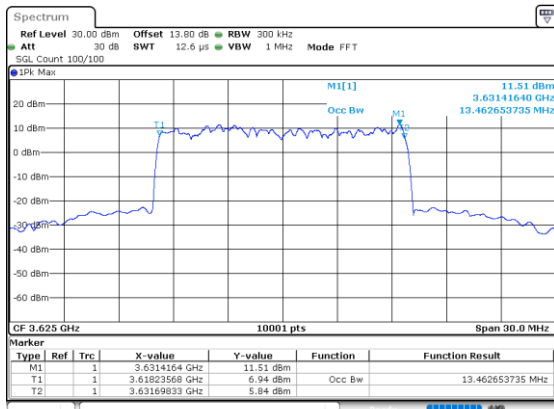

Date: 23.JUL.2024 16:45:22

Middle Channel / 20MHz / 64QAM

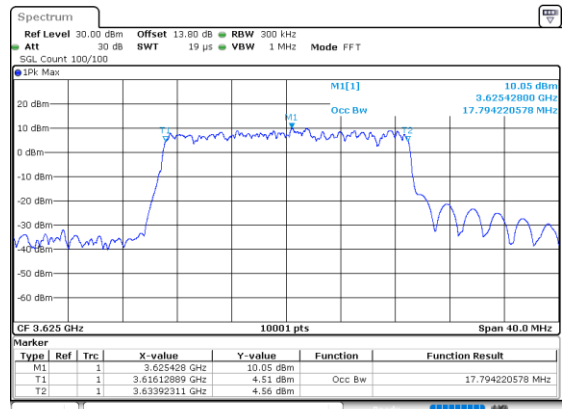

Date: 23.JUL.2024 16:58:41



LTE Band 48

Middle Channel / 5MHz / 256QAM

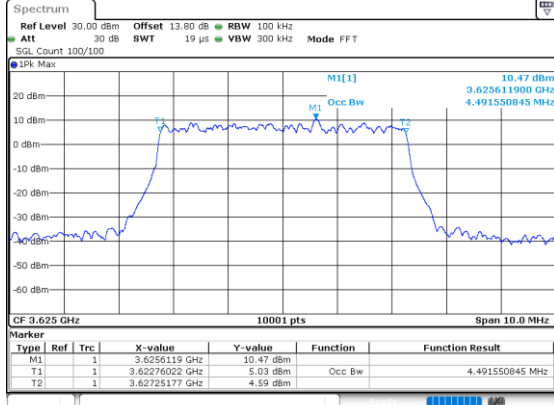

Date: 23.JUL.2024 17:11:22

Middle Channel / 10MHz / 256QAM

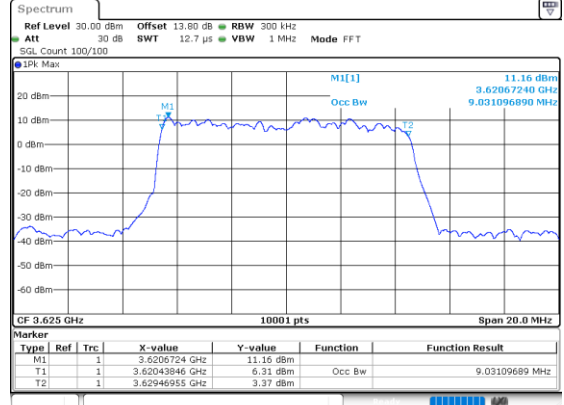

Date: 23.JUL.2024 17:15:53

Middle Channel / 15MHz / 256QAM

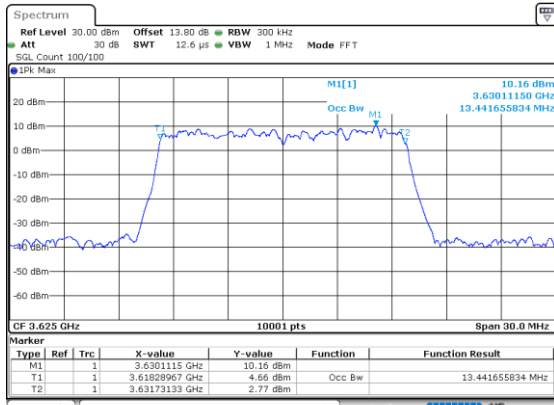

Date: 23.JUL.2024 17:20:05

Middle Channel / 20MHz / 256QAM

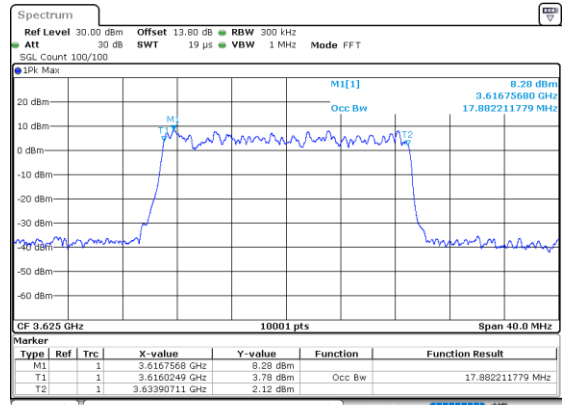

Date: 23.JUL.2024 17:24:20



ACLR

LTE Band 48 / 5MHz

QPSK

Lowest Channel / 1RB0

Lowest Channel / 1RBmax

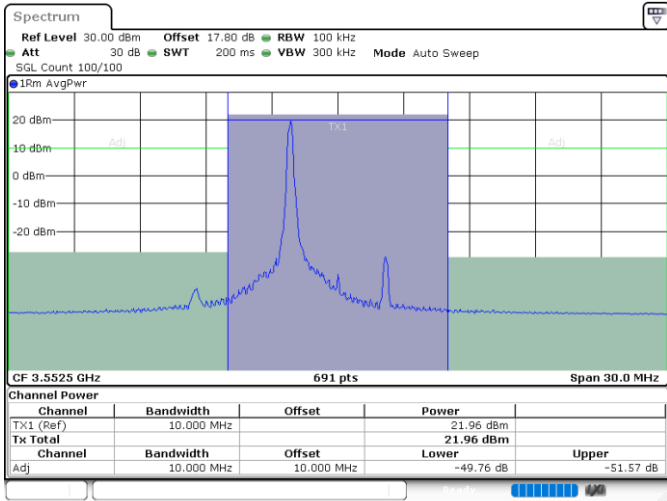

Date: 23.JUL.2024 15:50:29

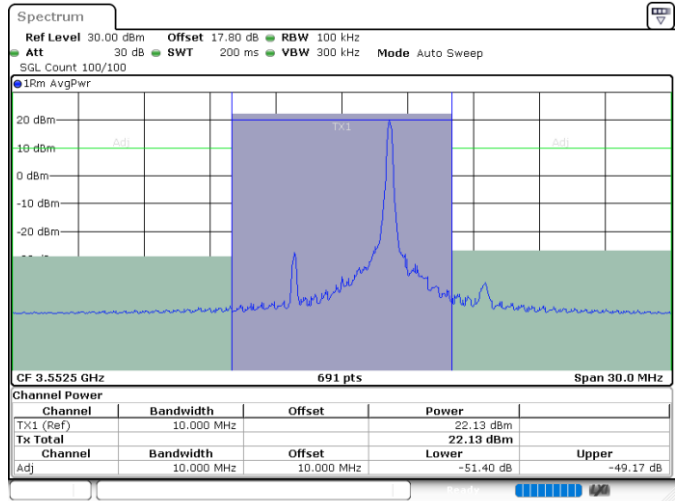

Date: 23.JUL.2024 16:08:04

Lowest Channel / FullIRB

N/A

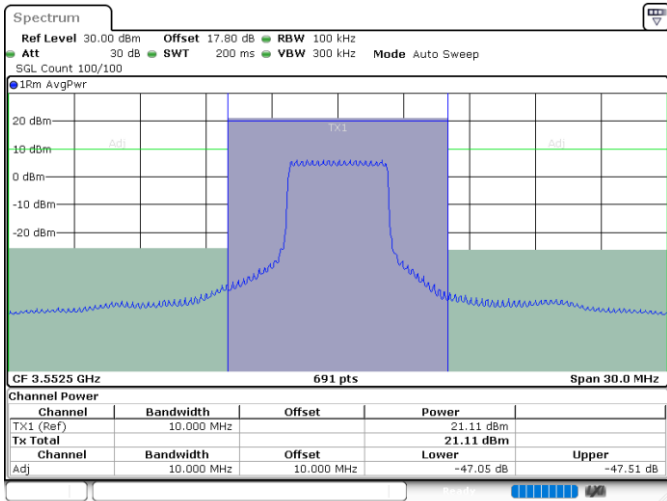

Date: 23.JUL.2024 15:59:17



LTE Band 48 / 5MHz

QPSK

Middle Channel / 1RB0

Middle Channel / 1RBmax

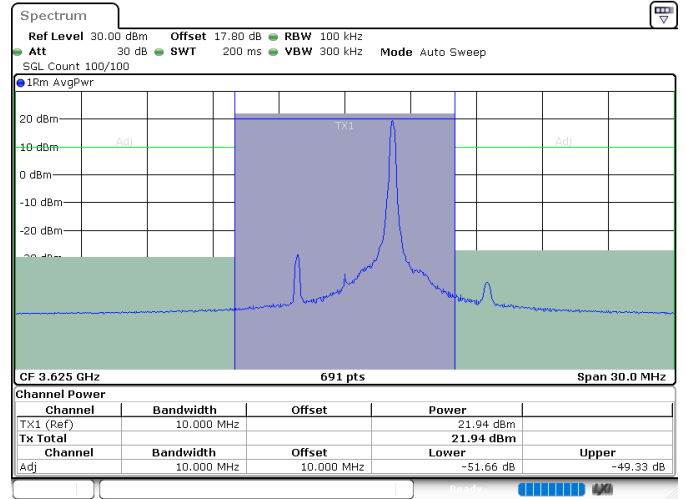
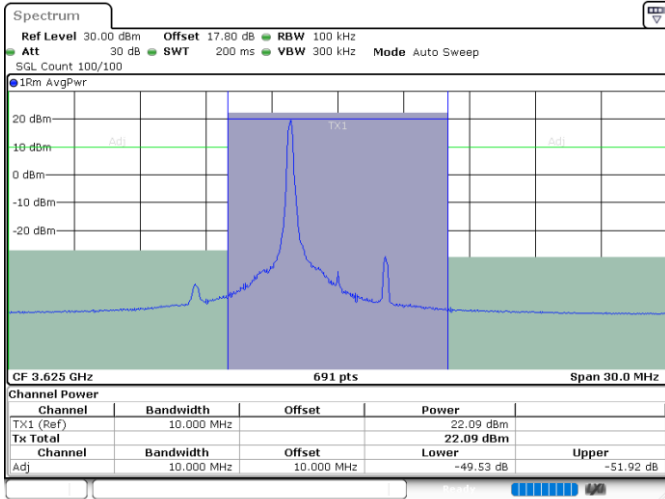

Middle Channel / FullIRB

N/A

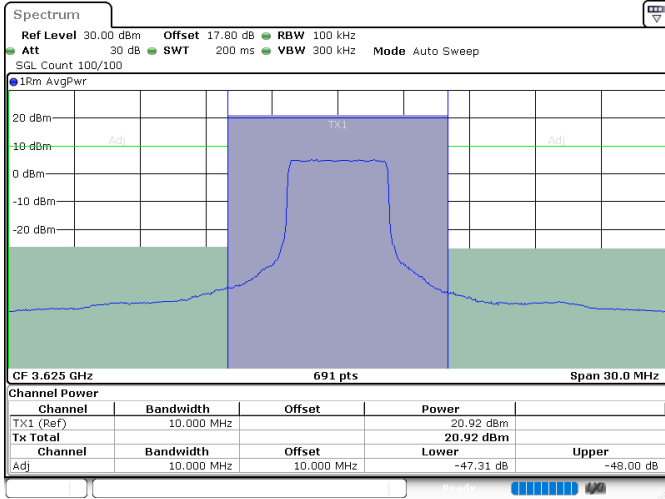



LTE Band 48 / 5MHz

QPSK

Highest Channel / 1RB0

Highest Channel / 1RBmax

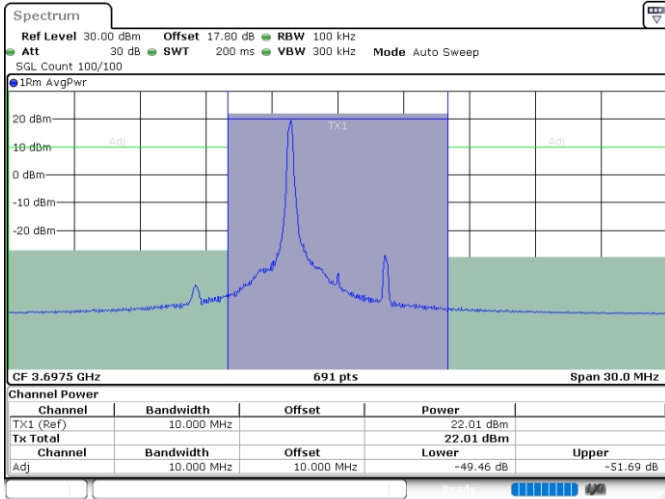

Date: 23.JUL.2024 15:56:20

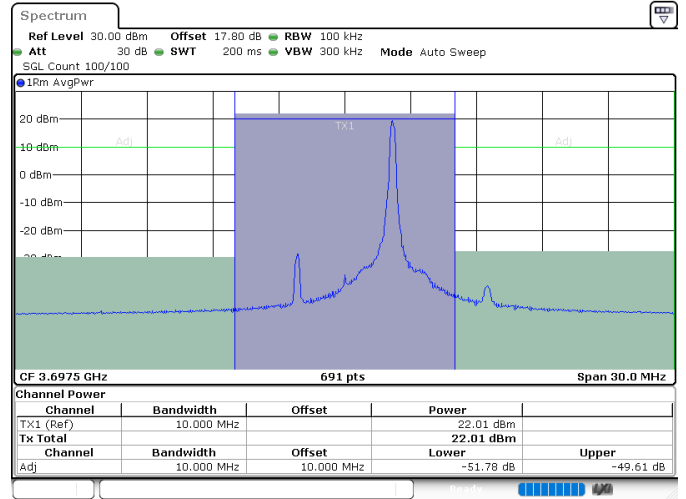

Date: 23.JUL.2024 16:13:56

Highest Channel / FullIRB

N/A

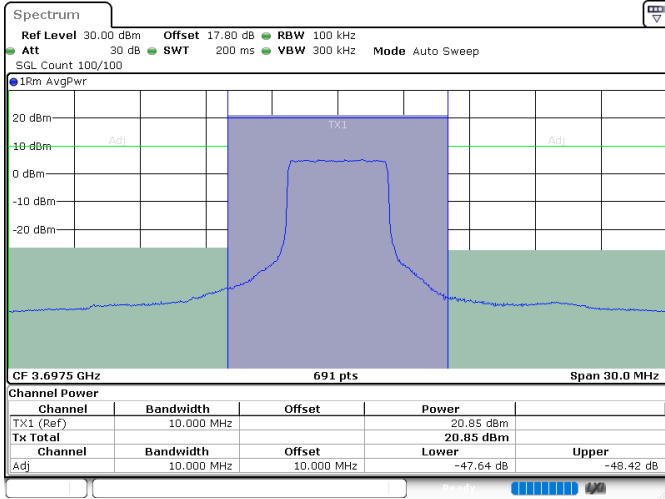

Date: 23.JUL.2024 16:05:07



LTE Band 48 / 10MHz

QPSK

Lowest Channel / FullIRB

Middle Channel / FullIRB

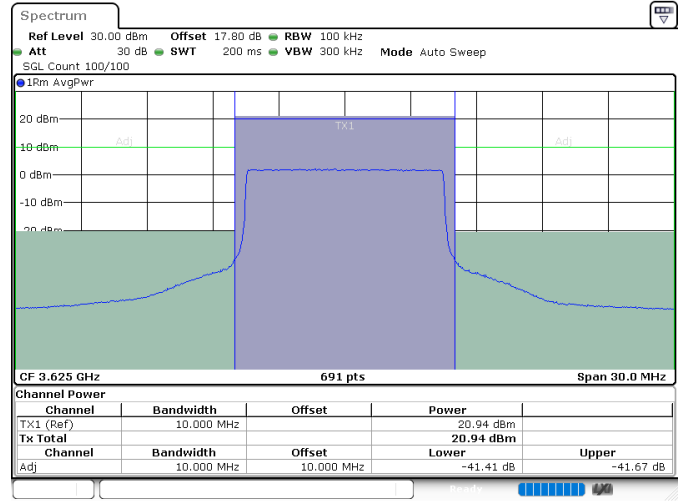
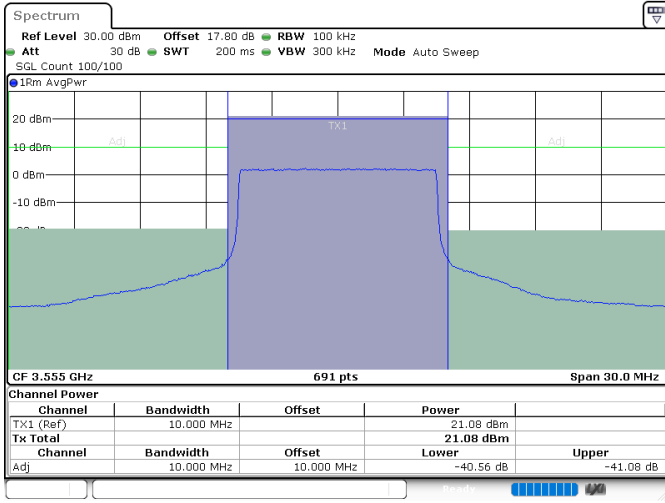

Highest Channel / FullIRB

N/A

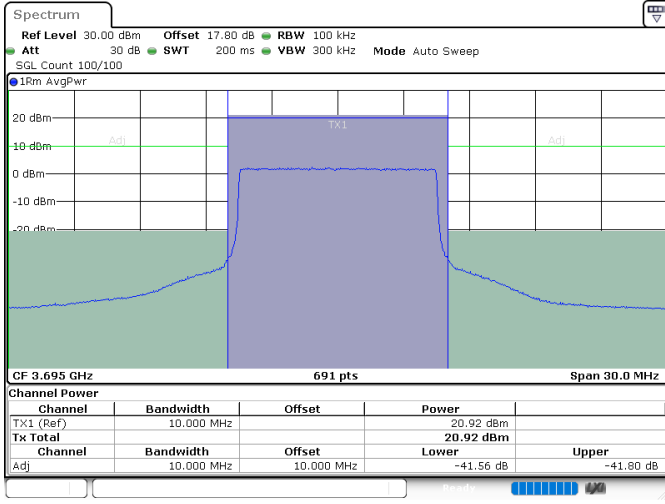



LTE Band 48 / 15MHz

QPSK

Lowest Channel / FullIRB

Middle Channel / FullIRB

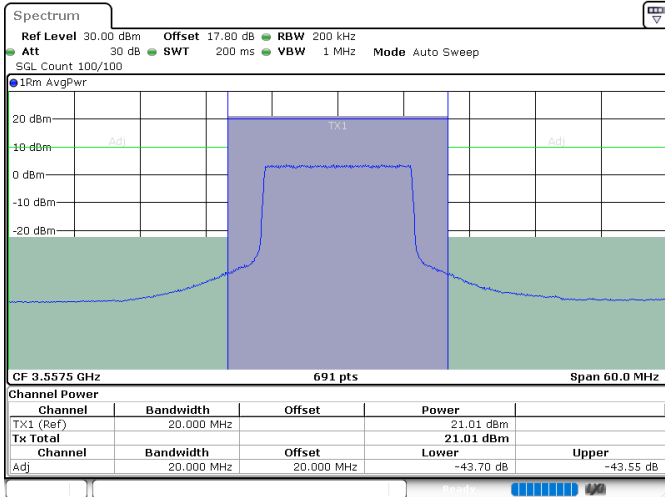

Date: 23.JUL.2024 16:34:09

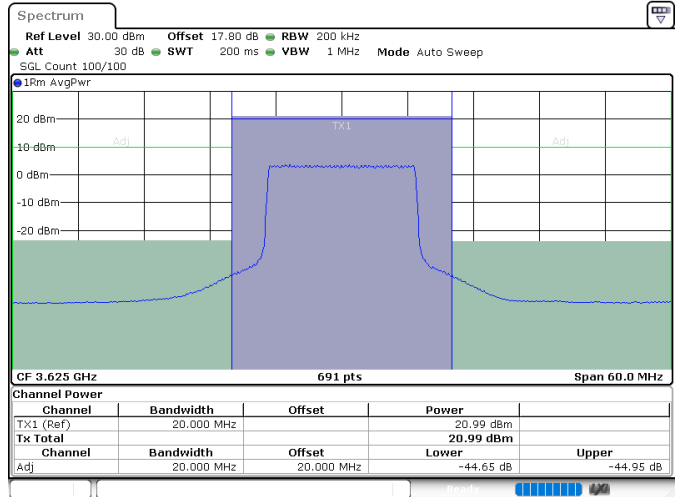

Date: 23.JUL.2024 16:38:59

Highest Channel / FullIRB

N/A

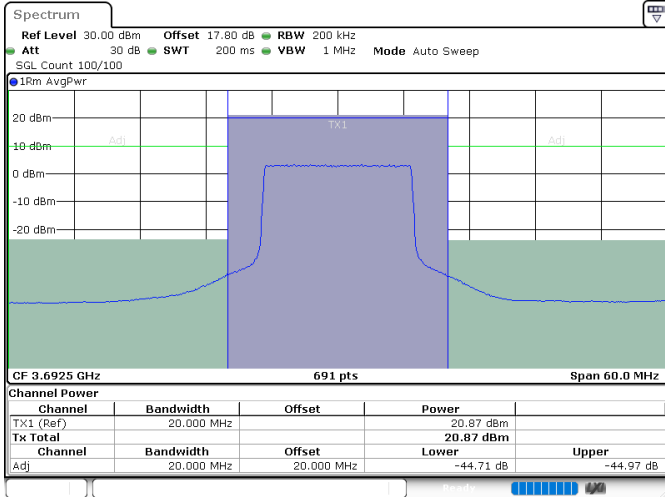

Date: 23.JUL.2024 16:39:55



LTE Band 48 / 20MHz

QPSK

Lowest Channel / FullIRB

Middle Channel / FullIRB

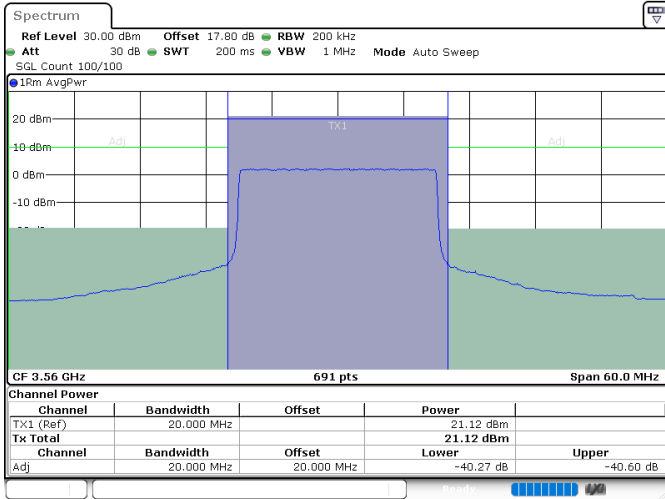

Date: 23.JUL.2024 16:49:09

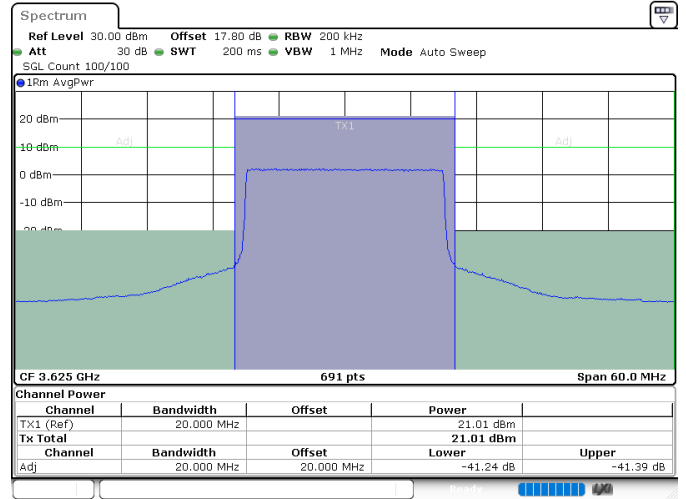

Date: 23.JUL.2024 16:50:07

Highest Channel / FullIRB

N/A

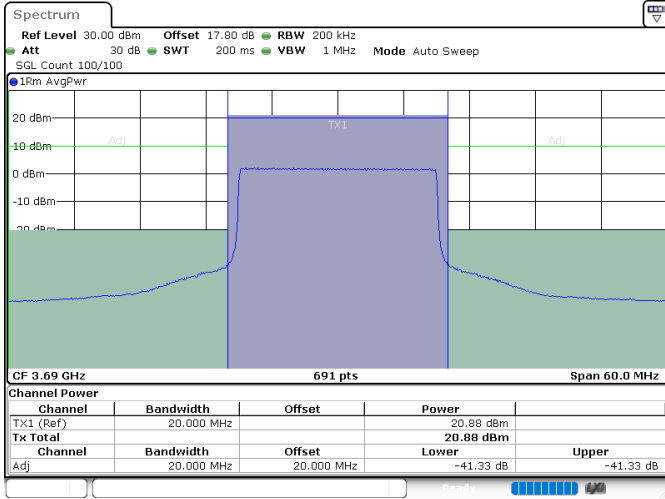

Date: 23.JUL.2024 16:54:52



LTE Band 48 / 5MHz

16QAM

Lowest Channel / 1RB0

Lowest Channel / 1RBmax

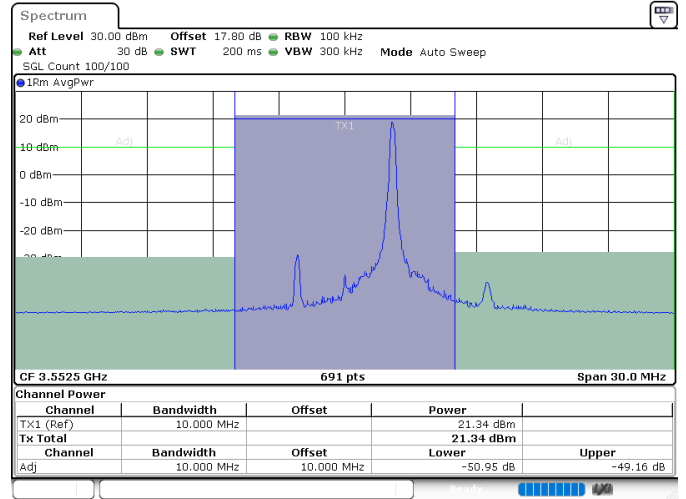
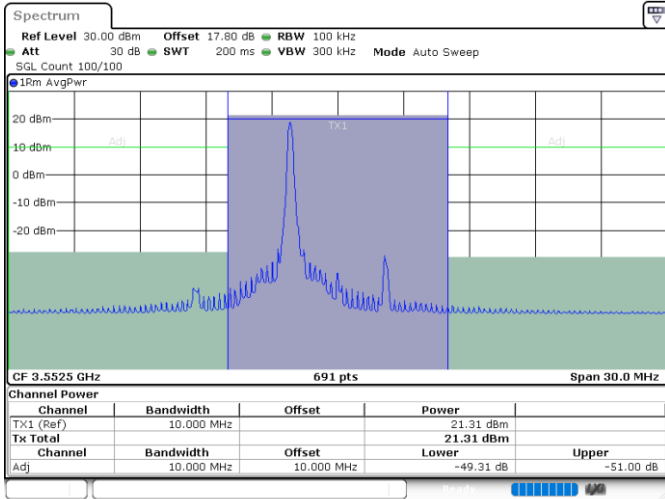

Lowest Channel / FullIRB

N/A

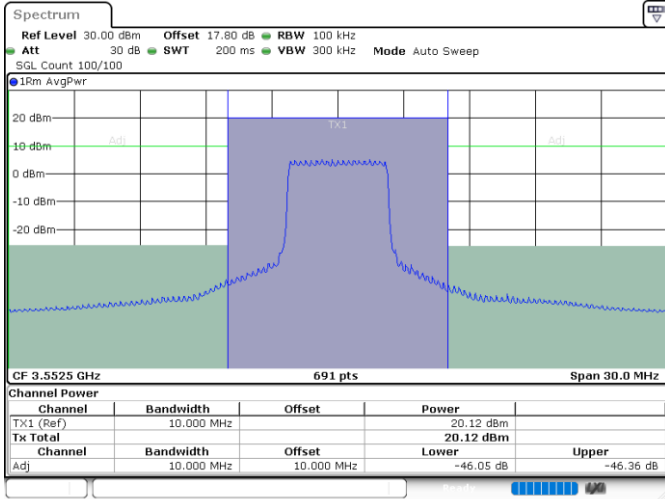



LTE Band 48 / 5MHz

16QAM

Middle Channel / 1RB0

Middle Channel / 1RBmax

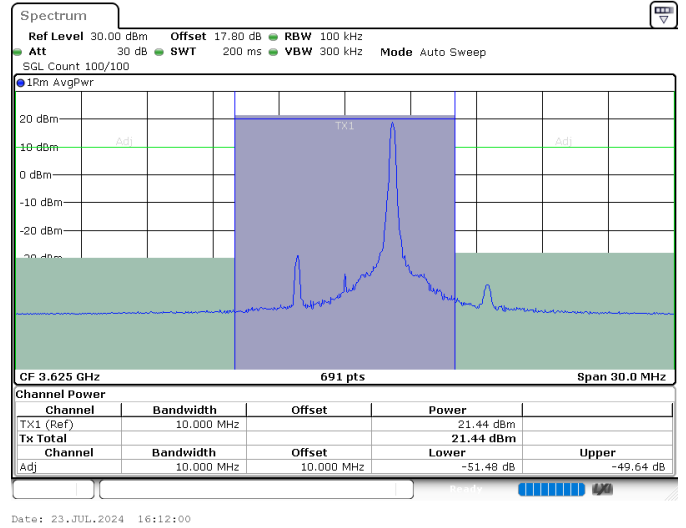
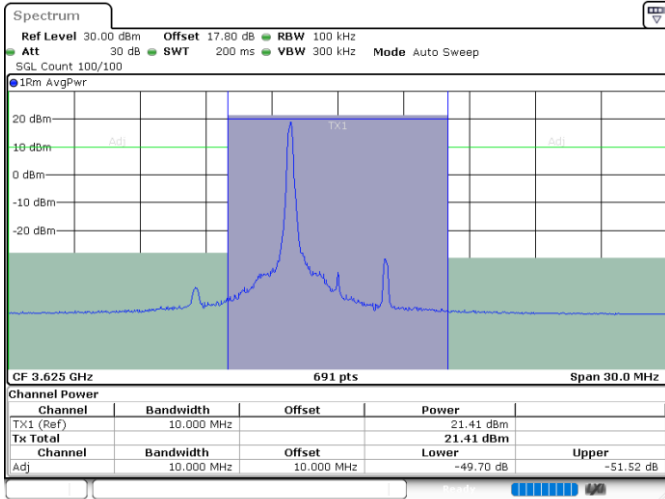

Middle Channel / FullRB

N/A

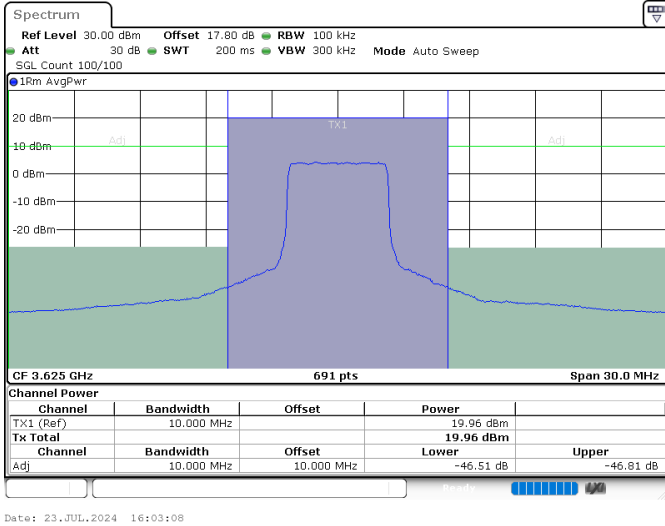



LTE Band 48 / 5MHz

16QAM

Highest Channel / 1RB0

Highest Channel / 1RBmax

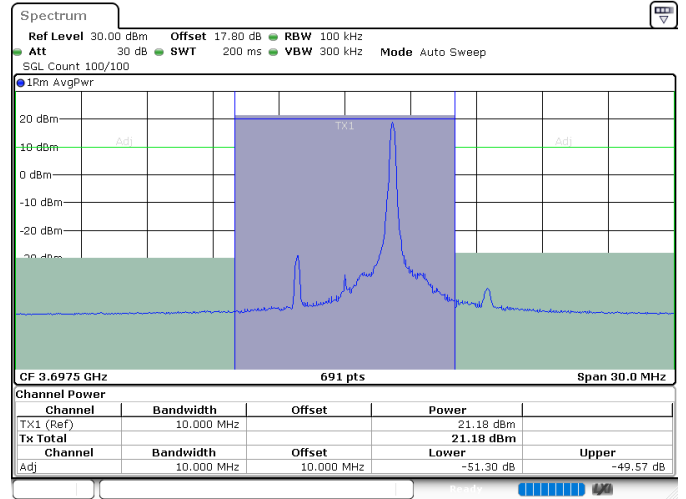
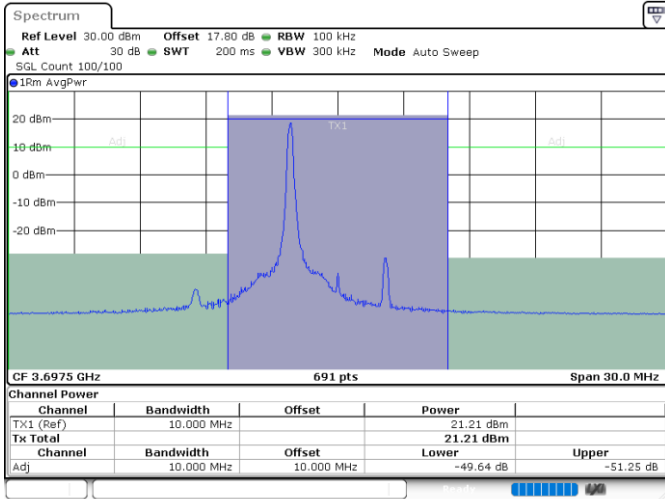

Highest Channel / FullIRB

N/A

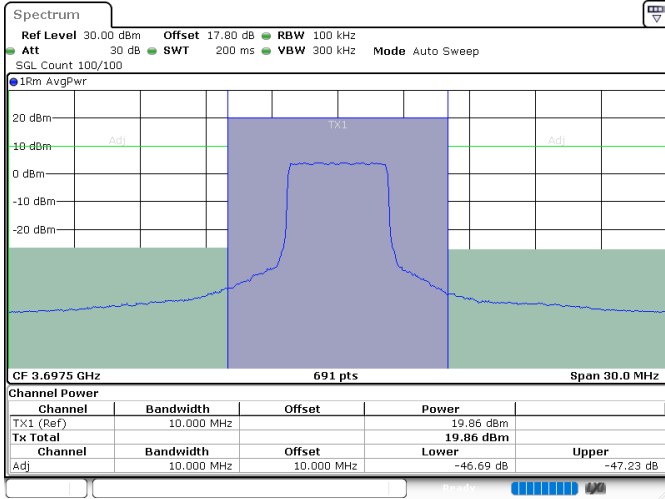



LTE Band 48 / 10MHz

16QAM

Lowest Channel / FullIRB

Middle Channel / FullIRB

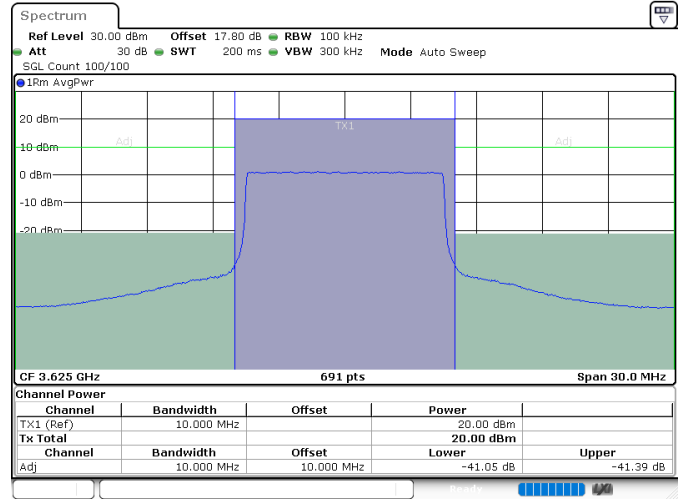
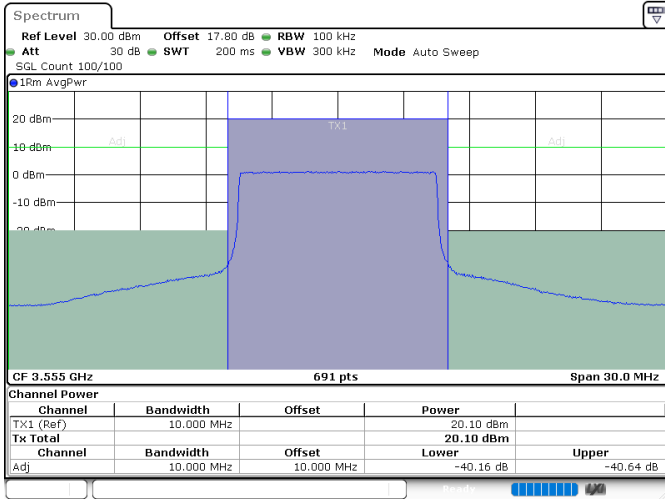

Date: 23.JUL.2024 16:21:52

Date: 23.JUL.2024 16:24:48

Highest Channel / FullIRB

N/A

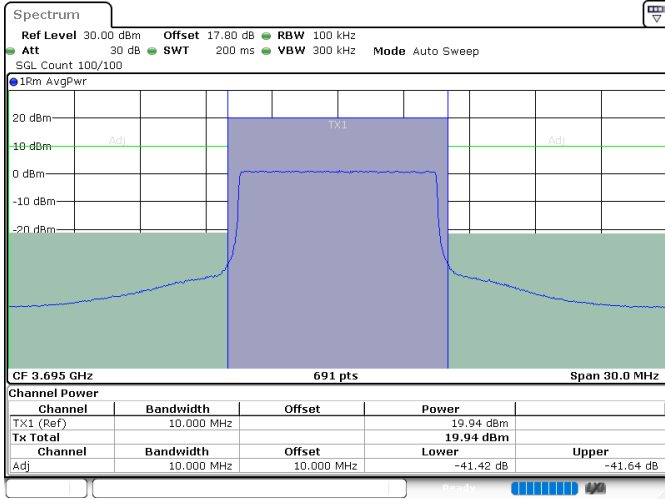

Date: 23.JUL.2024 16:27:47



LTE Band 48 / 15MHz

16QAM

Lowest Channel / FullIRB

Middle Channel / FullIRB

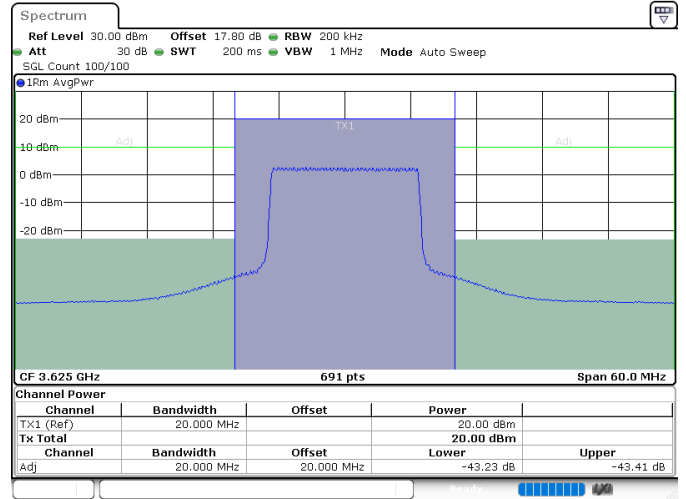
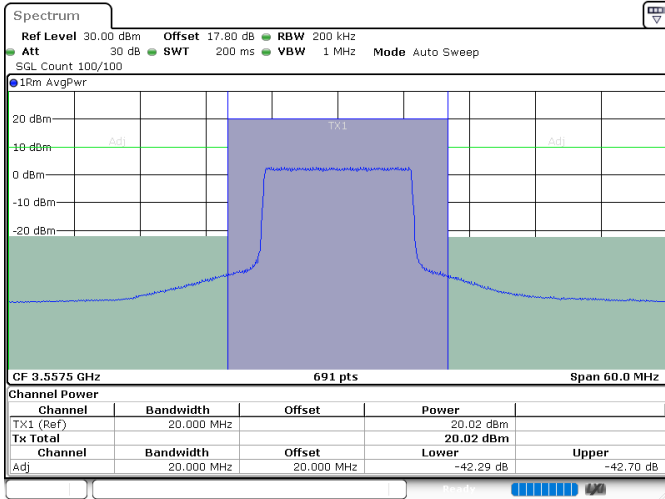

Highest Channel / FullIRB

N/A

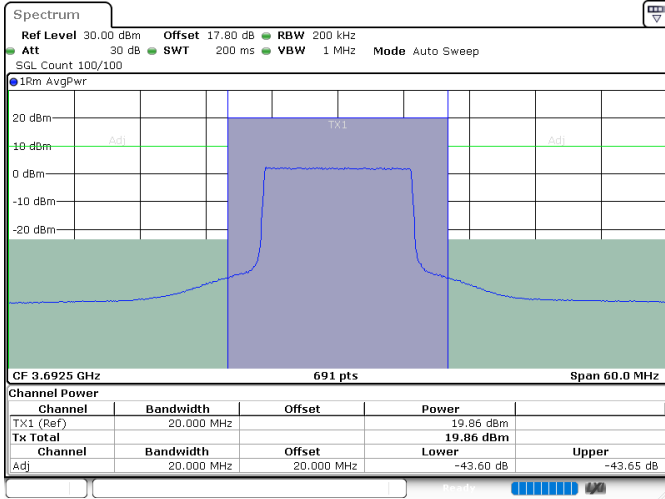



LTE Band 48 / 20MHz

16QAM

Lowest Channel / FullIRB

Middle Channel / FullIRB

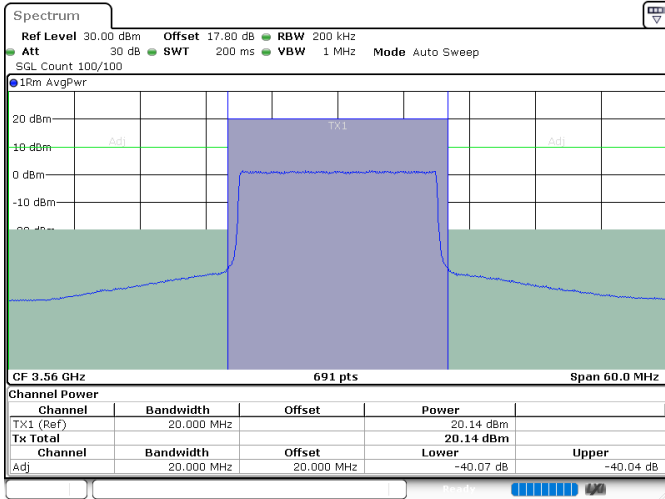

Date: 23.JUL.2024 16:48:11

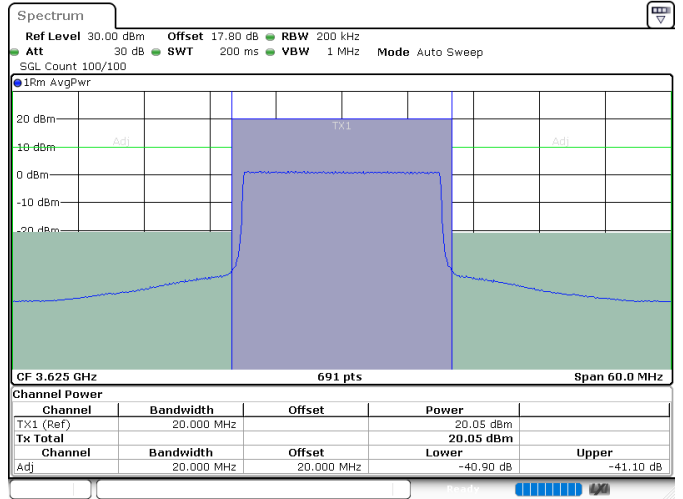

Date: 23.JUL.2024 16:51:02

Highest Channel / FullIRB

N/A

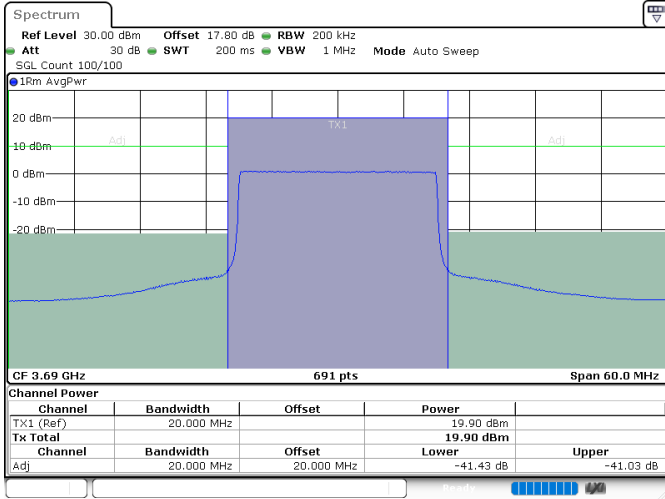

Date: 23.JUL.2024 16:53:54



LTE Band 48 / 5MHz

64QAM

Lowest Channel / 1RB0

Lowest Channel / 1RBmax

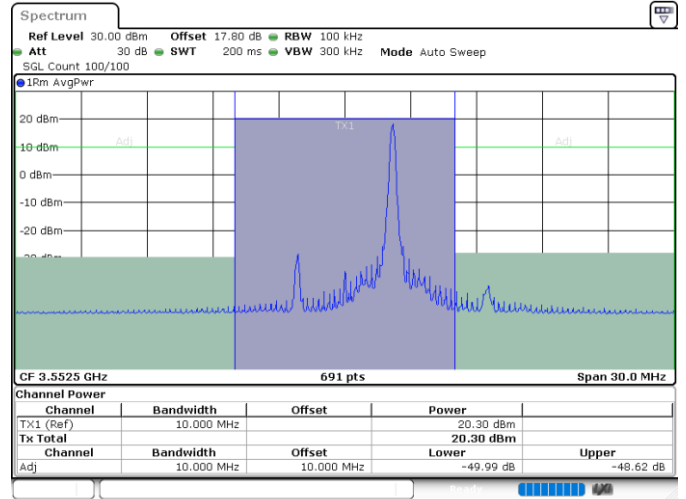
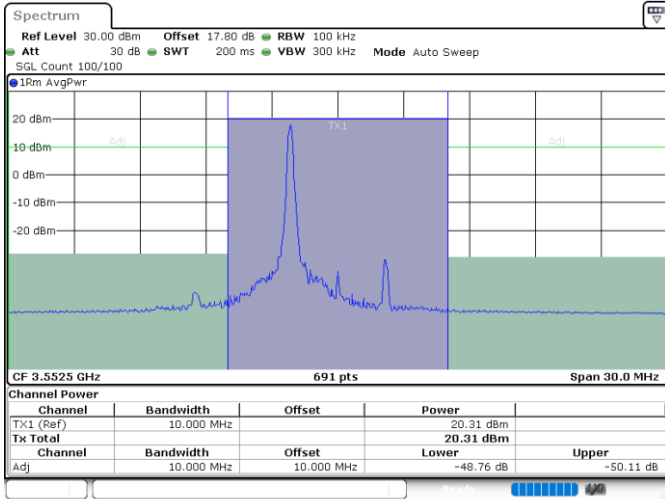

Lowest Channel / FullIRB

N/A

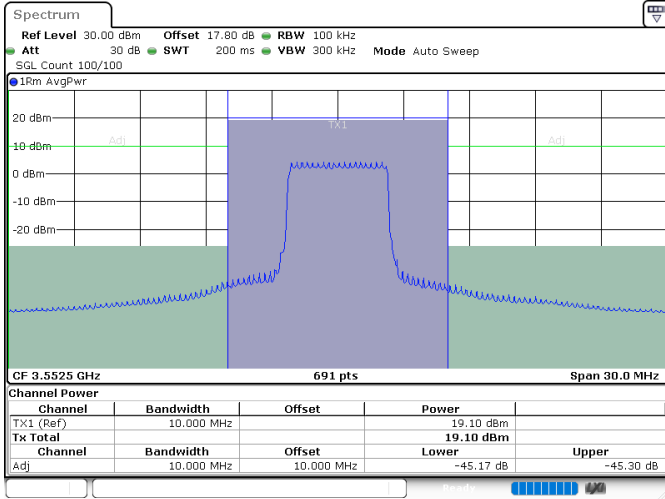



LTE Band 48 / 5MHz

64QAM

Middle Channel / 1RB0

Middle Channel / 1RBmax

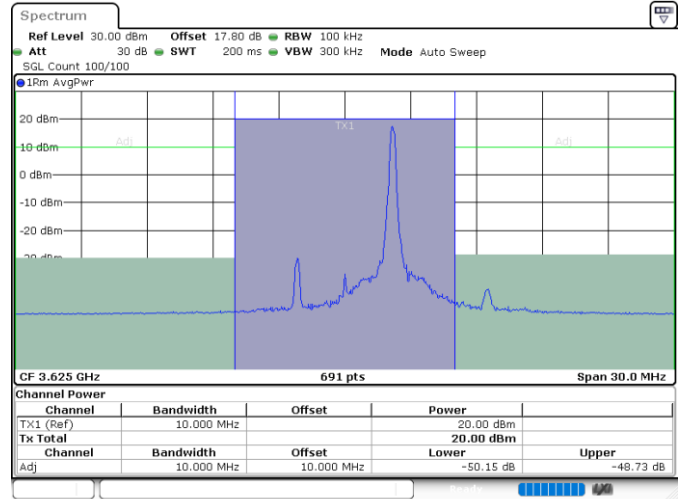
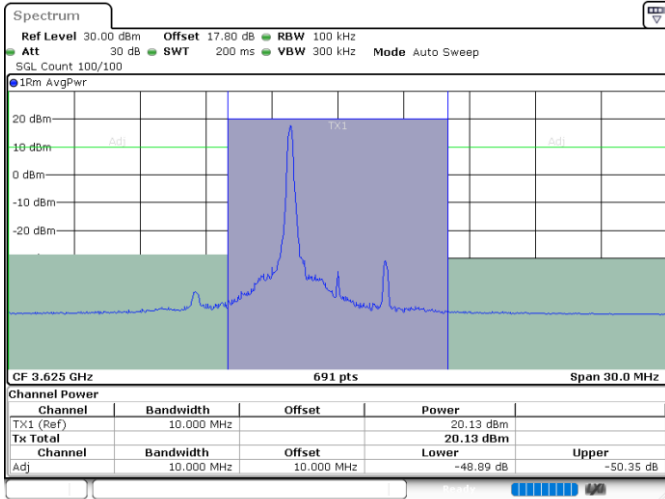

Middle Channel / FullRB

N/A

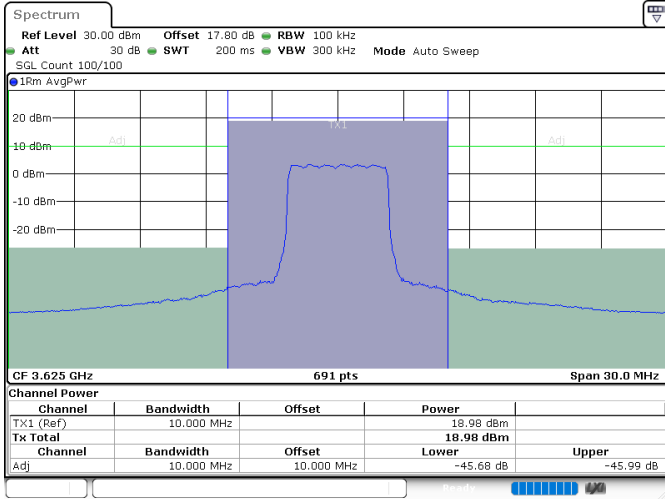



LTE Band 48 / 5MHz

64QAM

Highest Channel / 1RB0

Highest Channel / 1RBmax

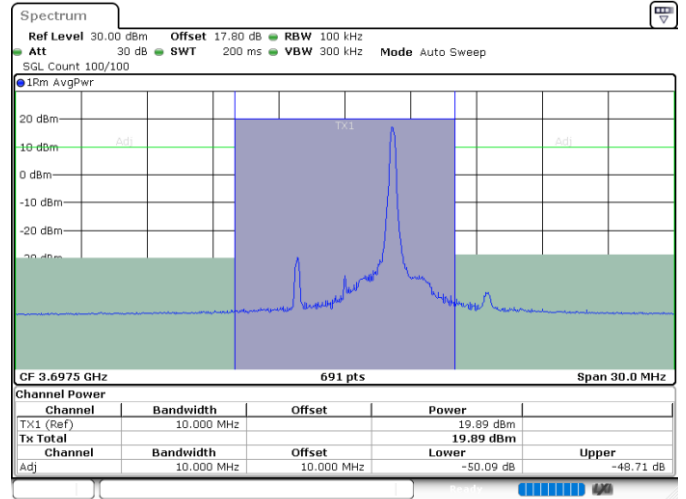
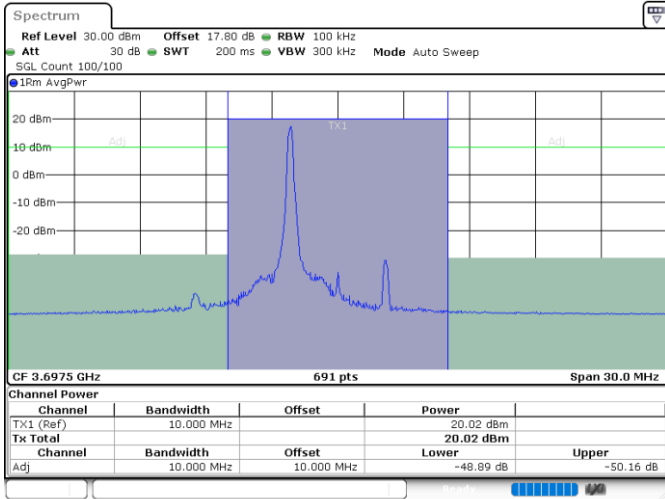

Highest Channel / FullIRB

N/A

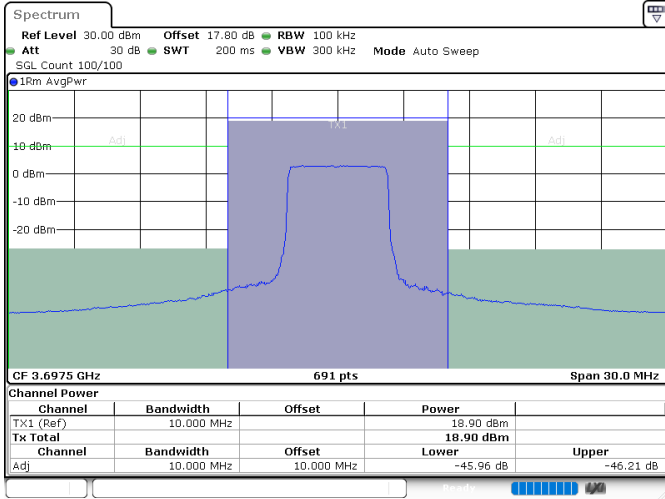



LTE Band 48 / 10MHz

64QAM

Lowest Channel / FullIRB

Middle Channel / FullIRB

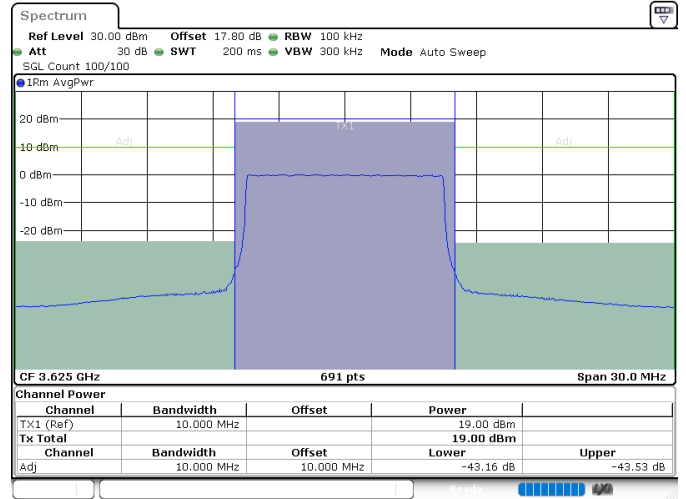
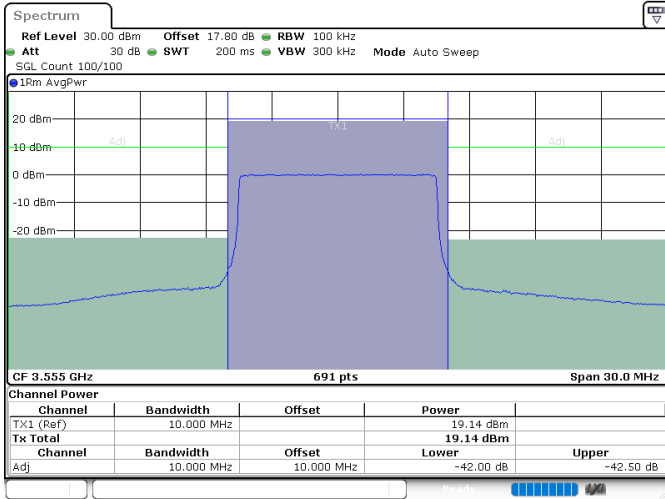

Highest Channel / FullIRB

N/A

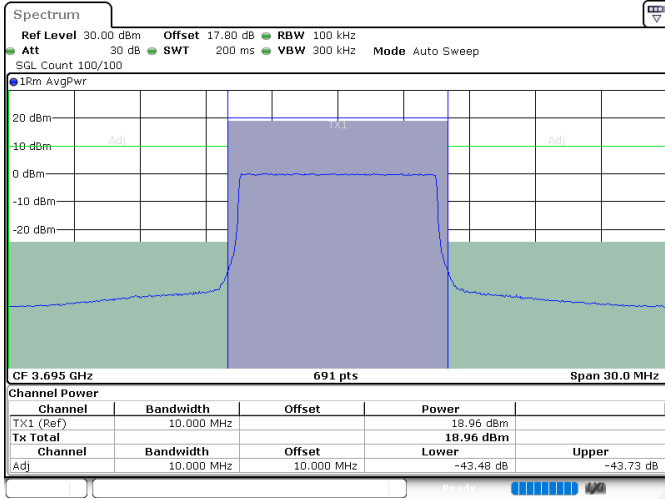



LTE Band 48 / 15MHz

64QAM

Lowest Channel / FullIRB

Middle Channel / FullIRB

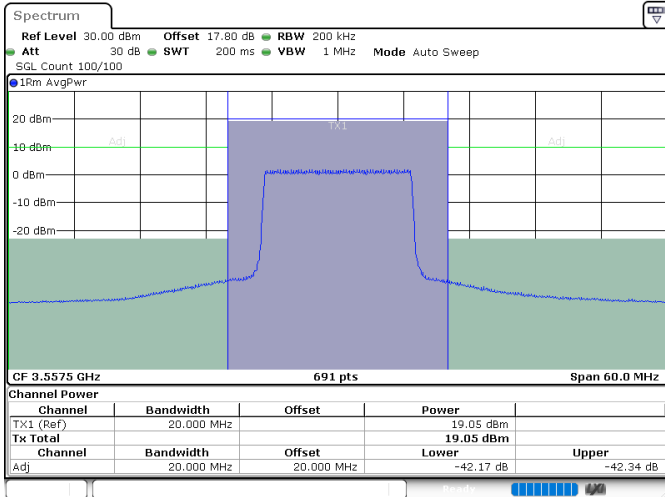

Date: 23.JUL.2024 16:36:10

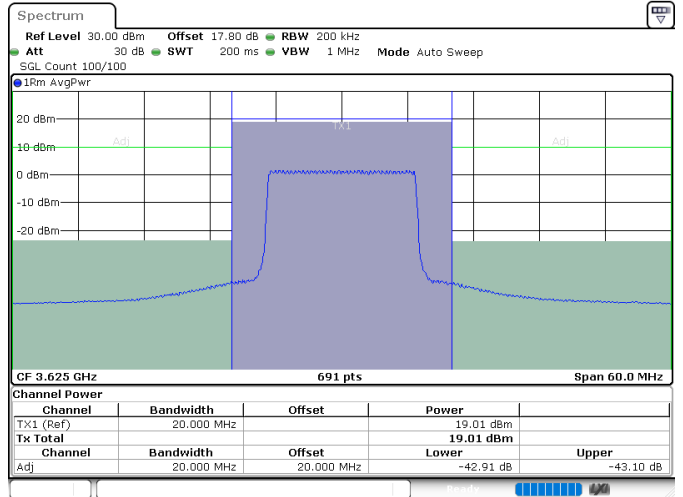

Date: 23.JUL.2024 16:37:07

Highest Channel / FullIRB

N/A

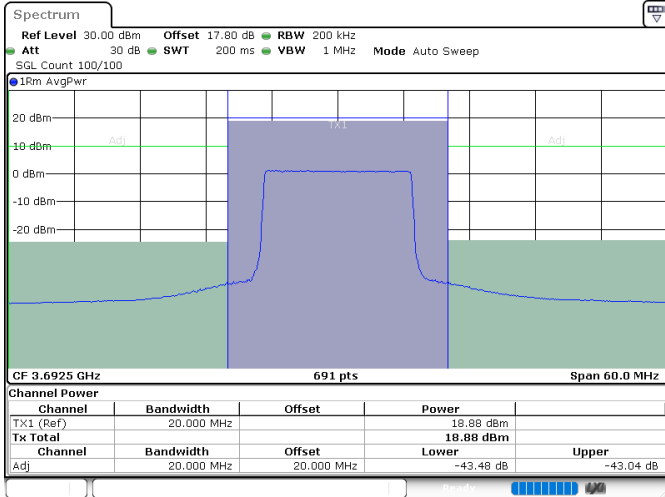

Date: 23.JUL.2024 16:41:56



LTE Band 48 / 20MHz

64QAM

Lowest Channel / FullIRB

Middle Channel / FullIRB

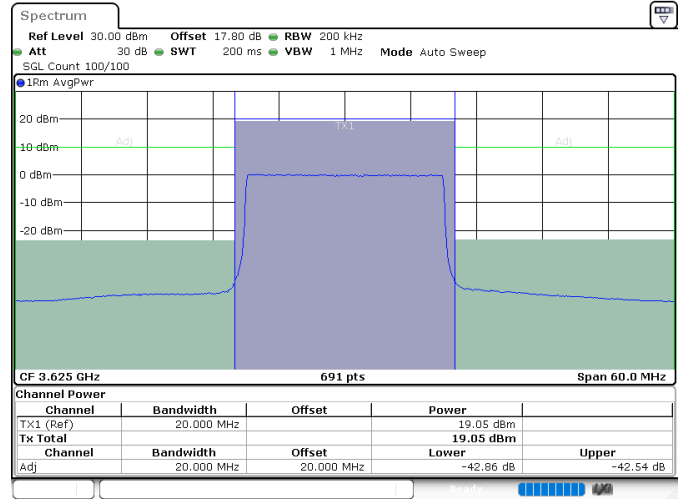
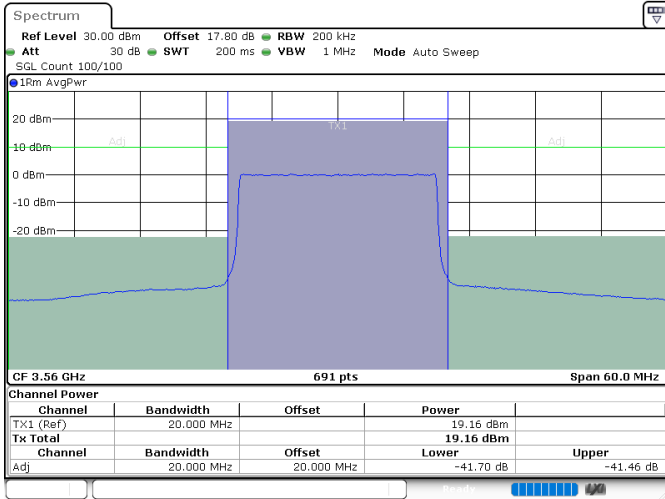

Highest Channel / FullIRB

N/A

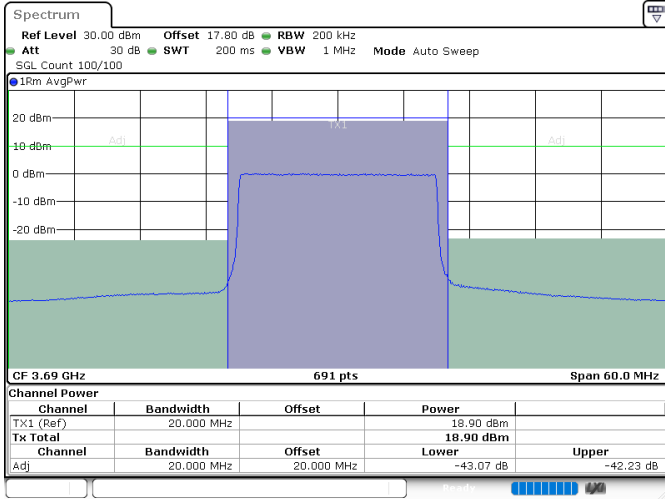



LTE Band 48 / 5MHz

256QAM

Lowest Channel / 1RB0

Lowest Channel / 1RBmax

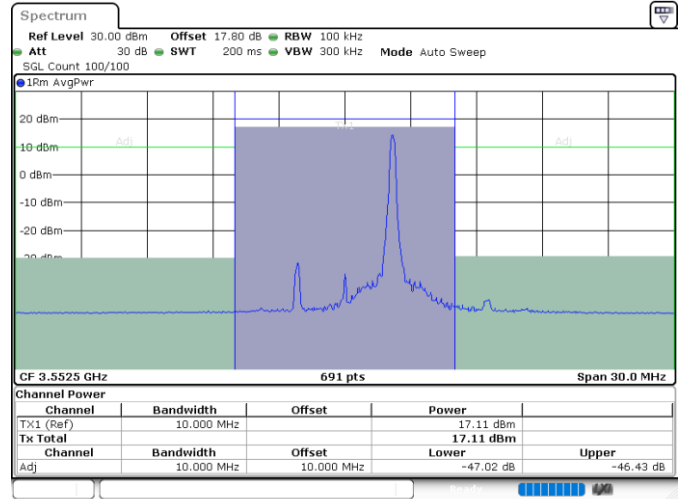
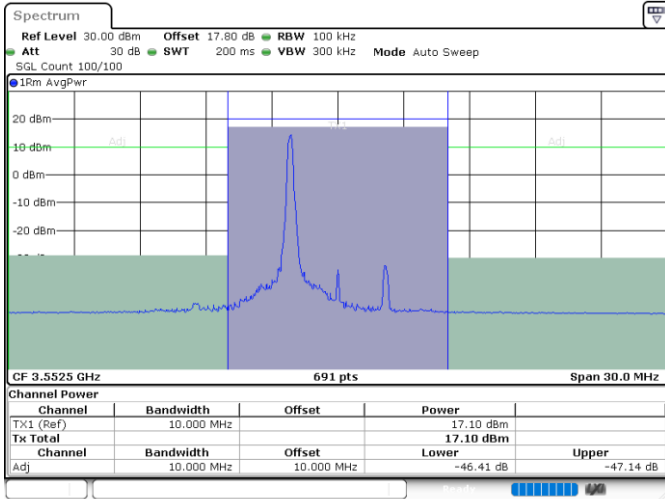

Lowest Channel / FullIRB

N/A

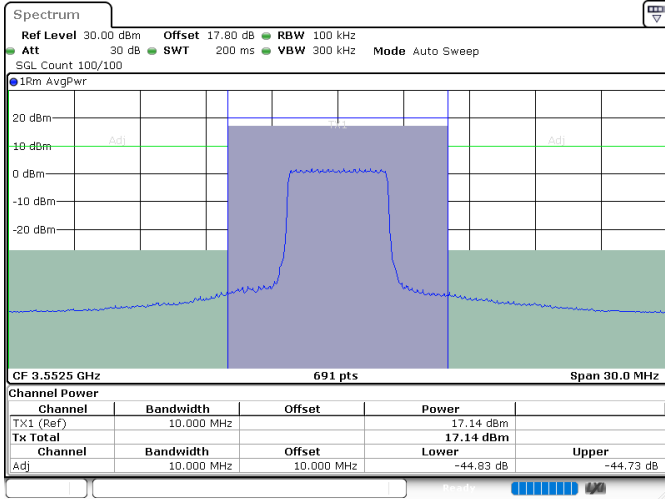



LTE Band 48 / 5MHz

256QAM

Middle Channel / 1RB0

Middle Channel / 1RBmax

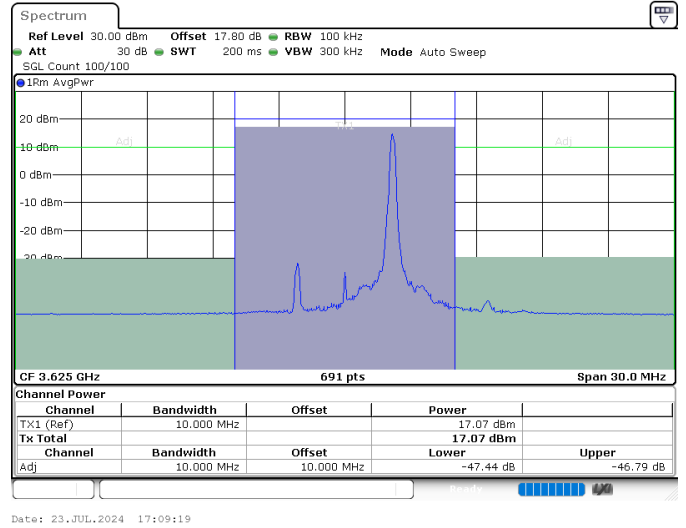
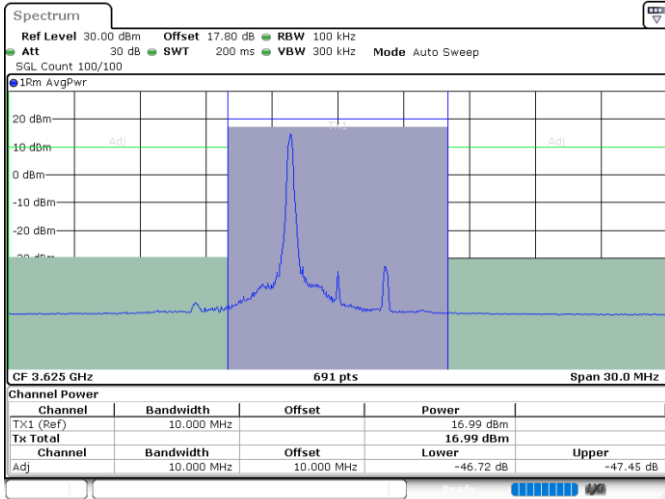

Middle Channel / FullIRB

N/A

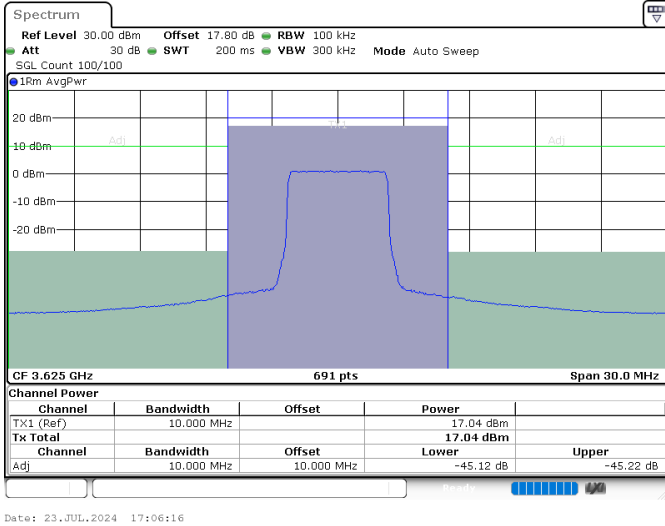



LTE Band 48 / 5MHz

256QAM

Highest Channel / 1RB0

Highest Channel / 1RBmax

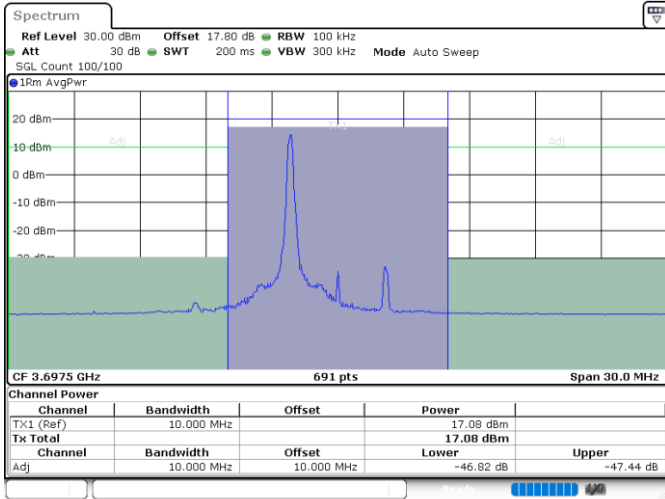

Date: 23.JUL.2024 17:04:18

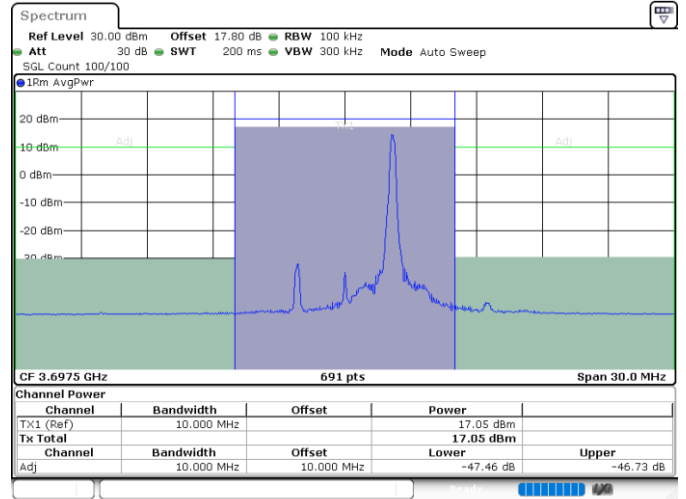

Date: 23.JUL.2024 17:10:20

Highest Channel / FullIRB

N/A

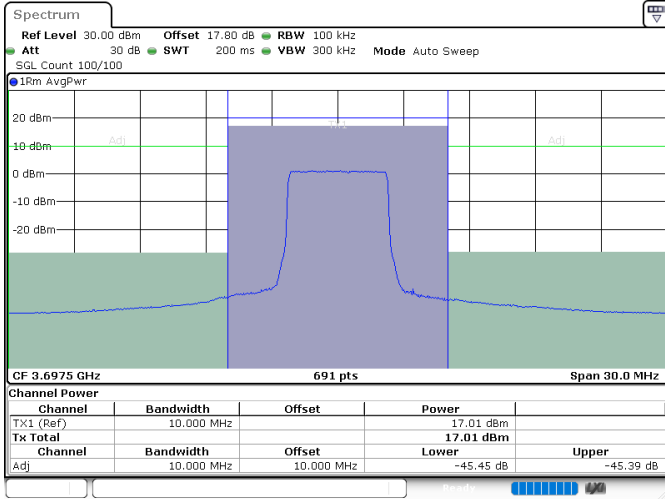

Date: 23.JUL.2024 17:07:19



LTE Band 48 / 10MHz

256QAM

Lowest Channel / FullIRB

Middle Channel / FullIRB

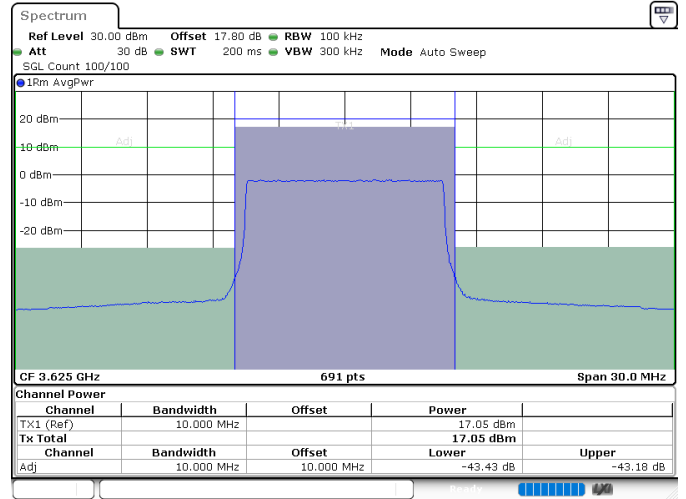
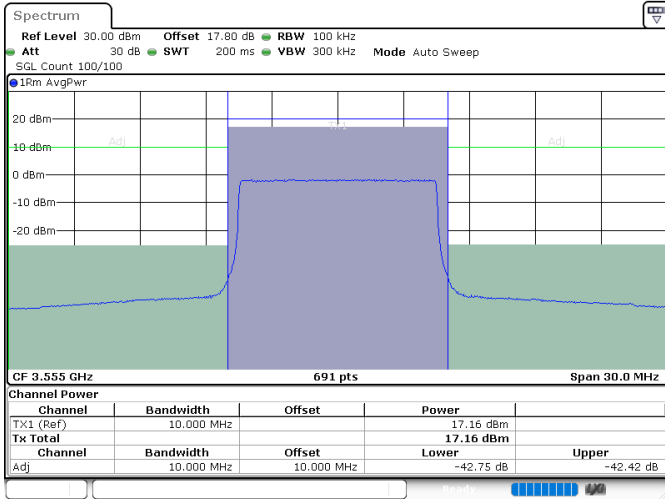

Highest Channel / FullIRB

N/A

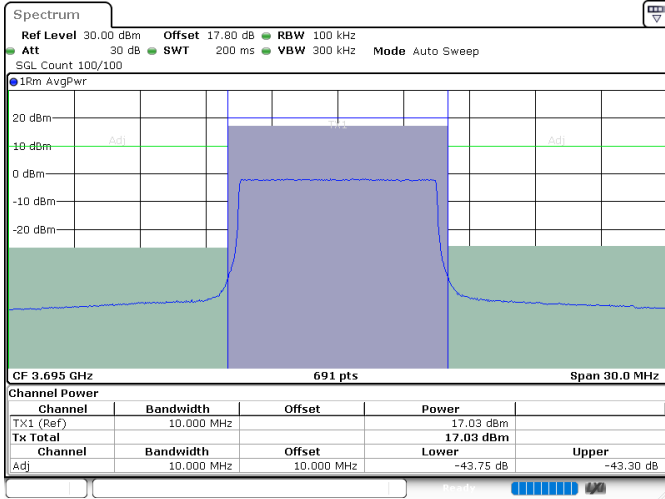



LTE Band 48 / 15MHz

256QAM

Lowest Channel / FullIRB

Middle Channel / FullIRB

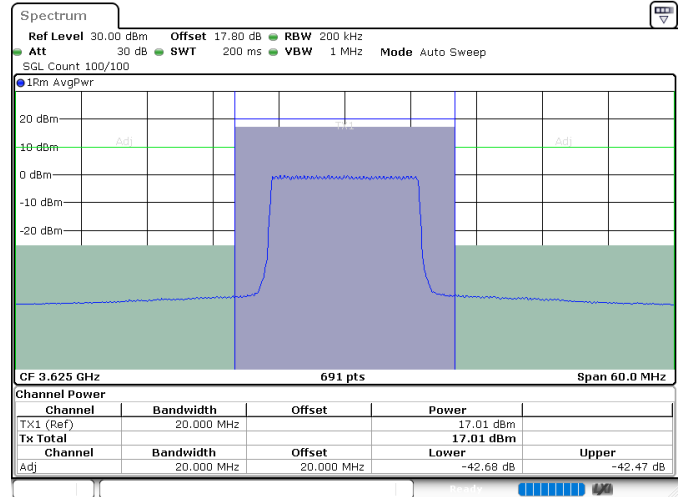
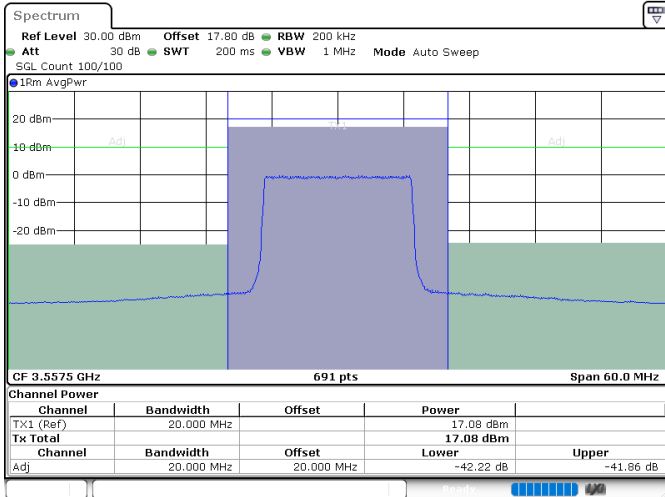

Date: 23.JUL.2024 17:17:18

Date: 23.JUL.2024 17:18:14

Highest Channel / FullIRB

N/A

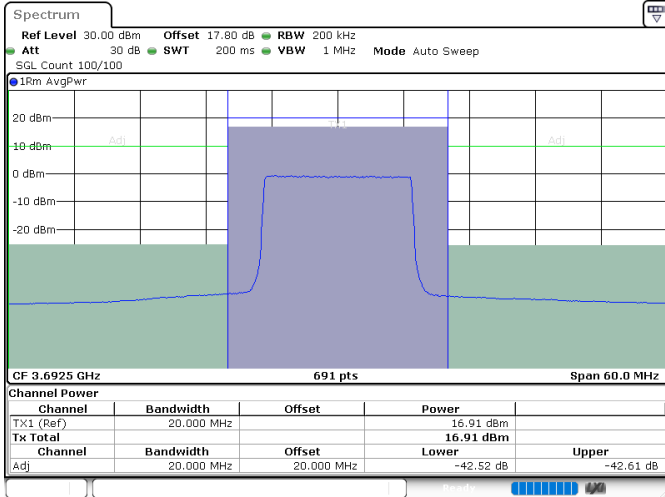

Date: 23.JUL.2024 17:19:09



LTE Band 48 / 20MHz

256QAM

Lowest Channel / FullIRB

Middle Channel / FullIRB

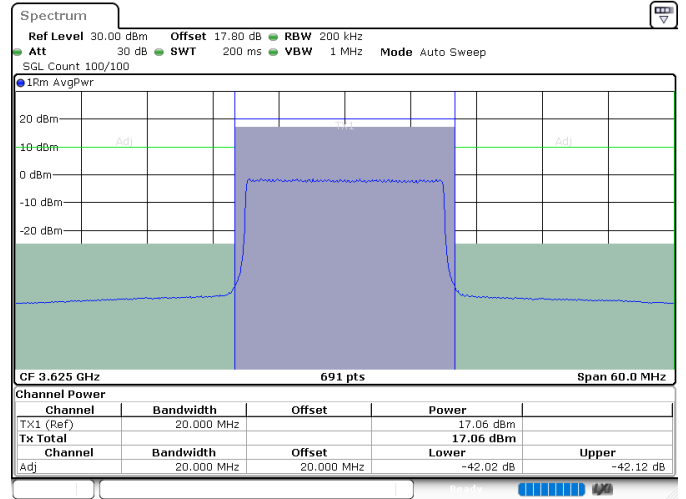
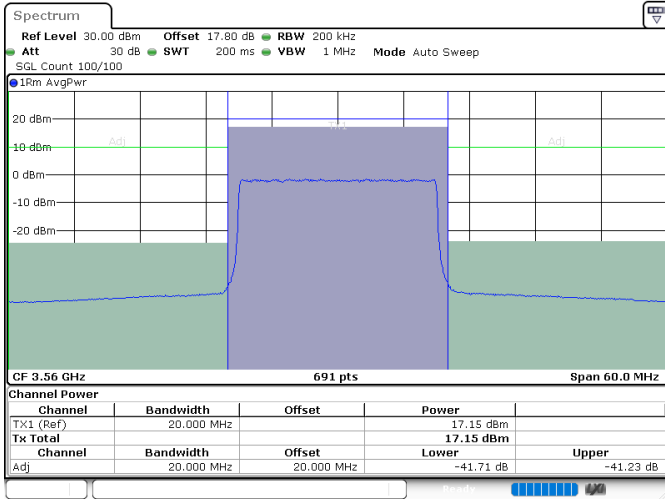

Highest Channel / FullIRB

N/A

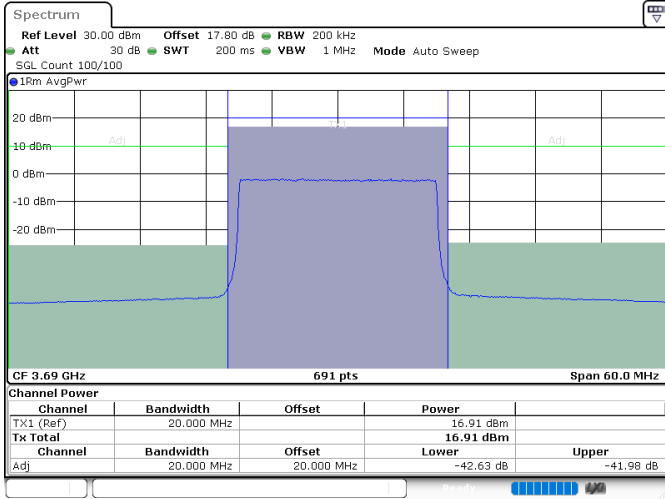



Conducted Band Edge

LTE Band 48 / 5MHz

QPSK

Lowest Channel / 1RB0

Lowest Channel / 1RBmax

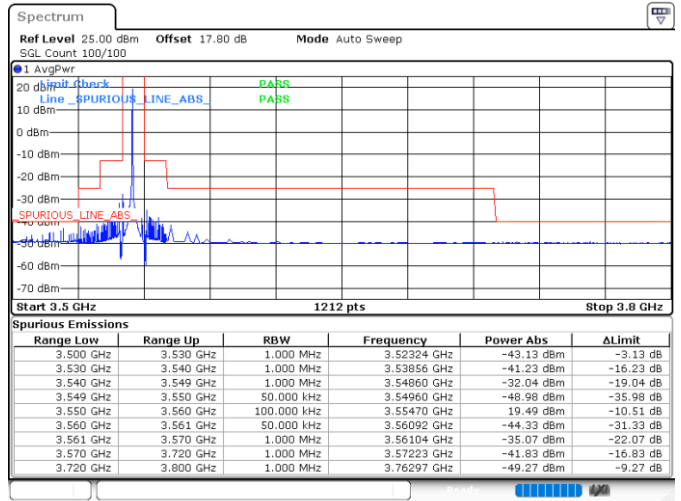
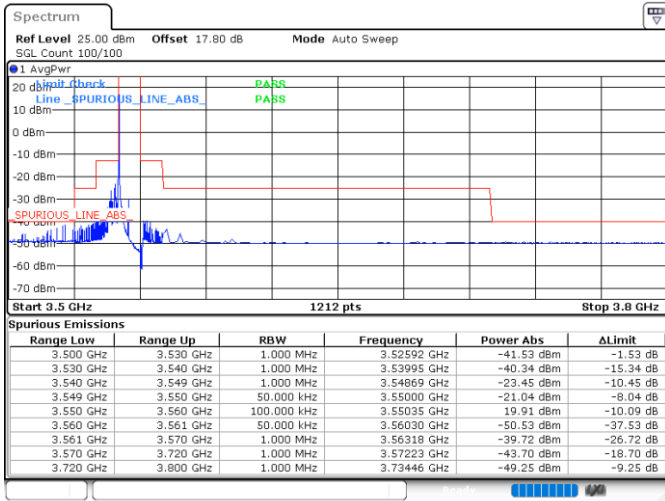

Date: 23.JUL.2024 17:53:56

Date: 23.JUL.2024 18:14:36

Lowest Channel / FullIRB

N/A

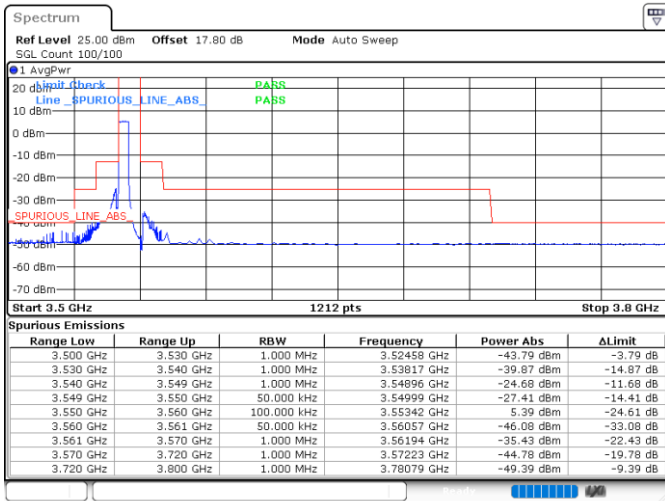

Date: 23.JUL.2024 18:04:15



LTE Band 48 / 5MHz

QPSK

Middle Channel / 1RB0

Middle Channel / 1RBmax

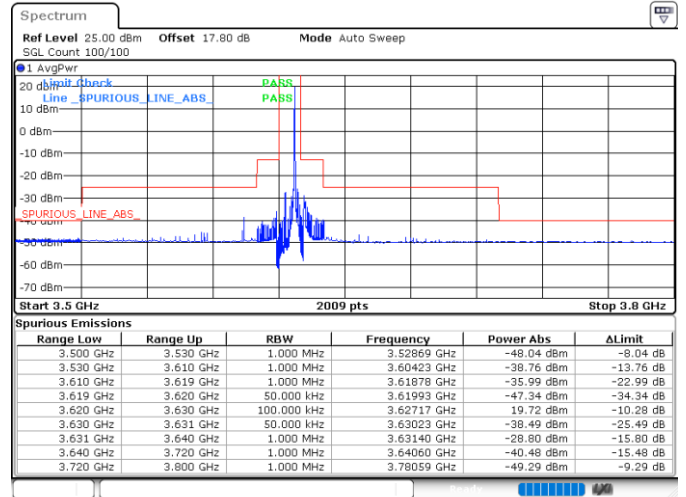
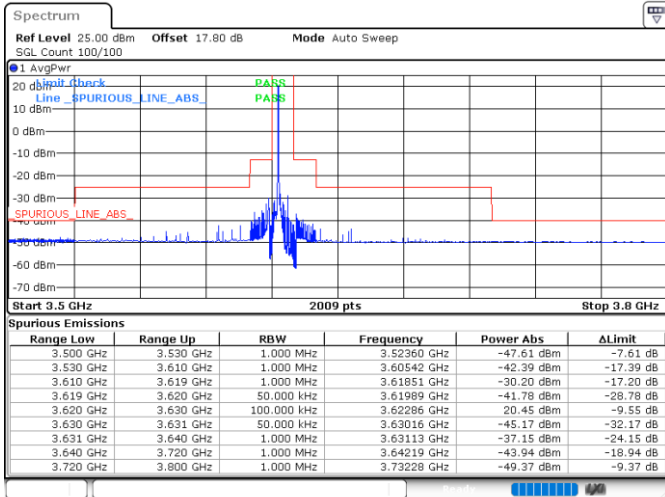

Date: 23.JUL.2024 17:59:42

Date: 23.JUL.2024 18:20:22

Middle Channel / FullIRB

N/A

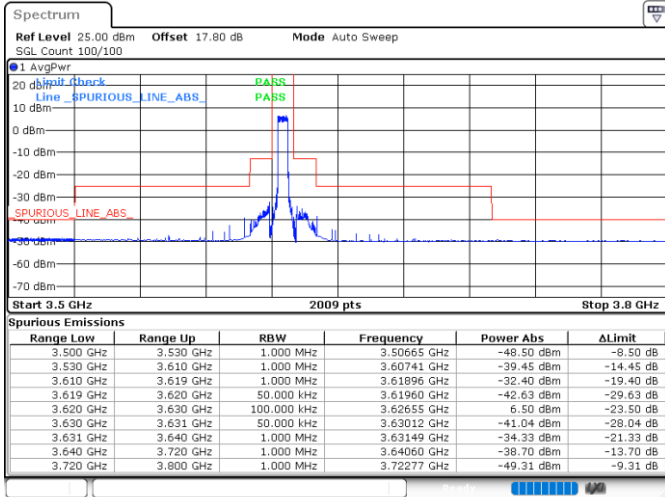

Date: 23.JUL.2024 18:09:55



LTE Band 48 / 5MHz

QPSK

Highest Channel / 1RB0

Highest Channel / 1RBmax

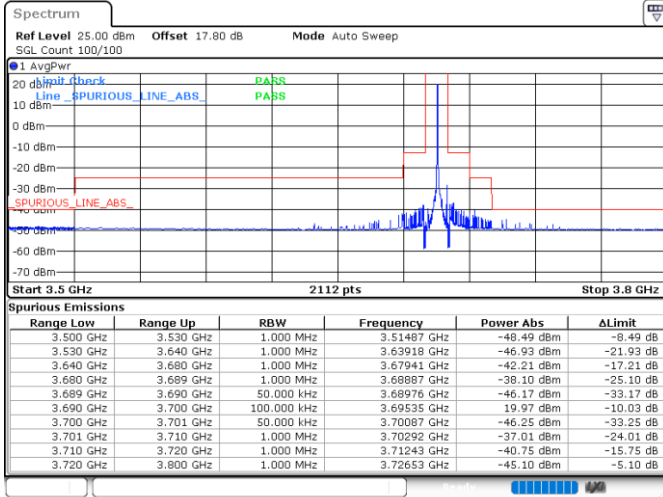

Date: 23.JUL.2024 18:00:50

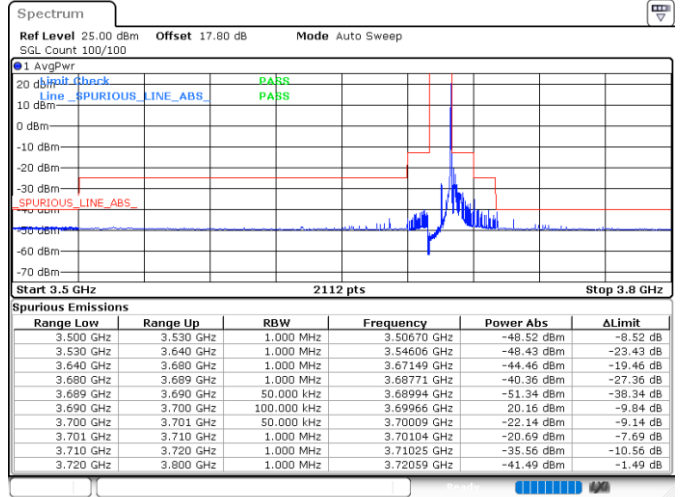

Date: 23.JUL.2024 18:21:29

Highest Channel / FullIRB

N/A

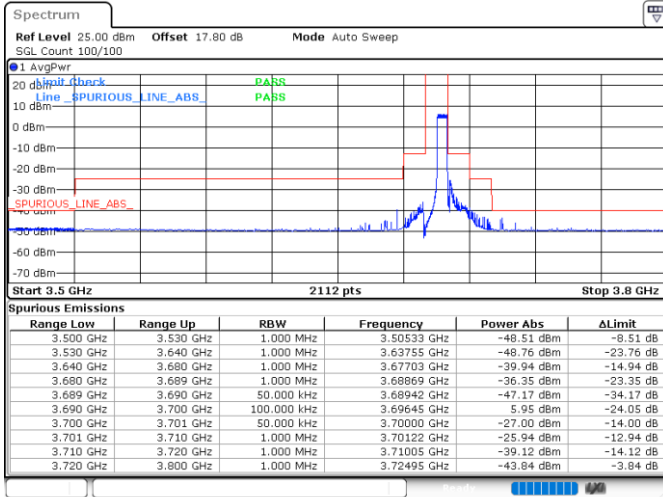

Date: 23.JUL.2024 18:11:03



LTE Band 48 / 10MHz

QPSK

Lowest Channel / FullIRB

Middle Channel / FullIRB

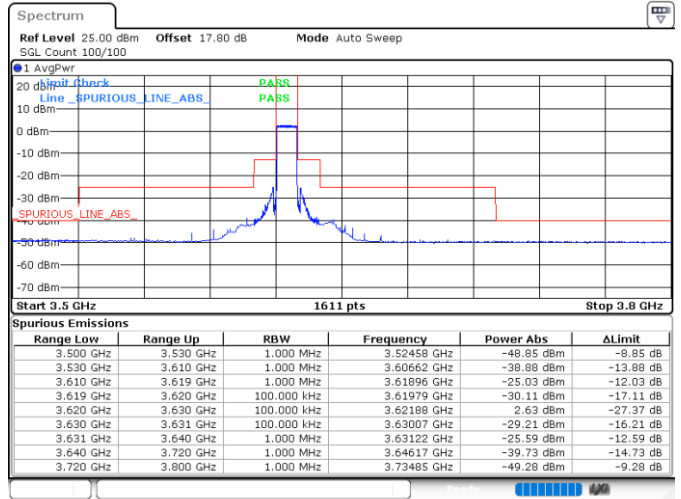
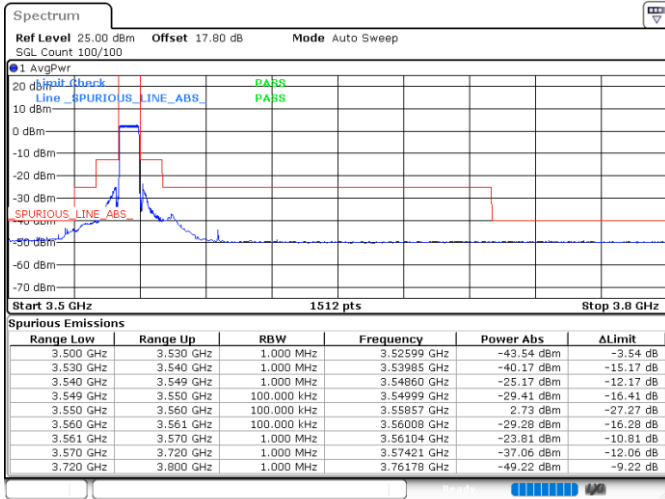

Date: 23.JUL.2024 19:52:47

Date: 23.JUL.2024 18:28:42

Highest Channel / FullIRB

N/A

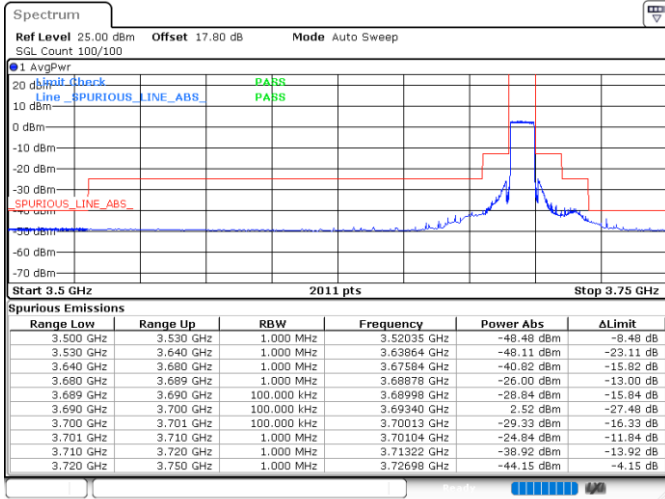

Date: 23.JUL.2024 18:34:29



LTE Band 48 / 15MHz

QPSK

Lowest Channel / FullIRB

Middle Channel / FullIRB

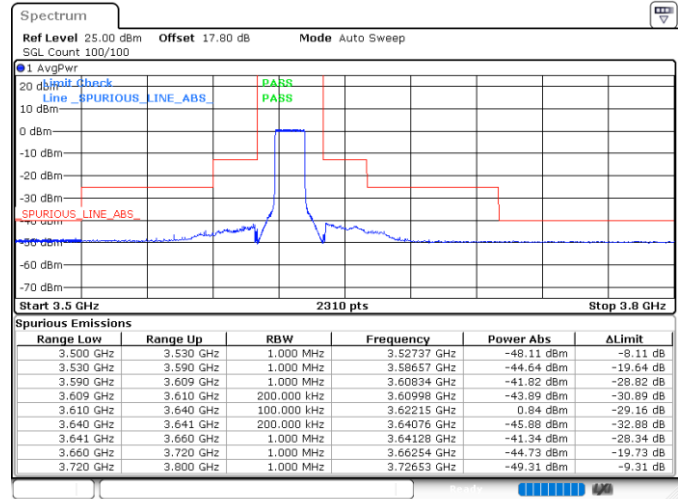
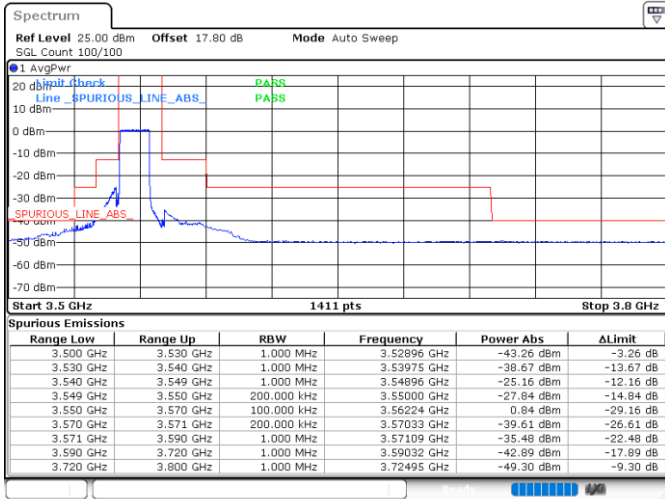

Date: 23.JUL.2024 18:35:43

Date: 23.JUL.2024 18:41:38

Highest Channel / FullIRB

N/A

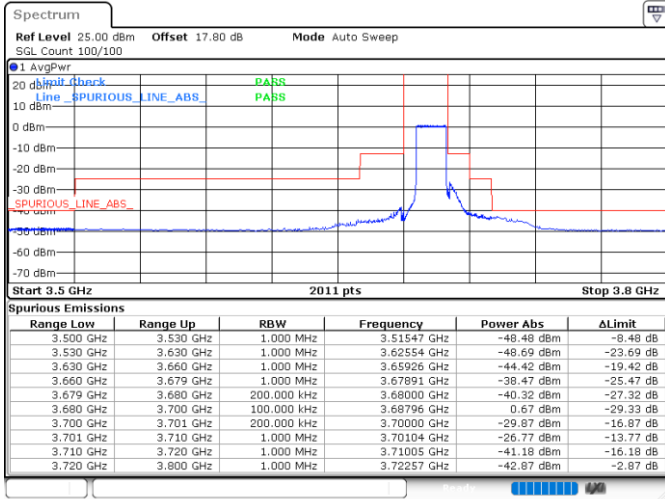

Date: 23.JUL.2024 18:42:46