



**FCC CFR47 PART 15 SUBPART E
INDUSTRY CANADA RSS-210 ISSUE 7**

CERTIFICATION TEST REPORT

FOR

DC544D_1 PCIe DAUGHTER CARD FOR 2.4 / 5 GHz CLIENT APPLICATIONS

MODEL NUMBER: 65-VN780-P1

**FCC ID: J9C-DC544D1
IC: 2723A-DC544D1**

REPORT NUMBER: 09U12687-1, Revision C

ISSUE DATE: OCTOBER 6, 2009

Prepared for
**QUALCOMM, INC.
3165 KIFER ROAD
SANTA CLARA, CA 95051, U.S.A.**

Prepared by
**COMPLIANCE CERTIFICATION SERVICES
47173 BENICIA STREET
FREMONT, CA 94538, U.S.A.
TEL: (510) 771-1000
FAX: (510) 661-0888**



NVLAP LAB CODE 200065-0

Revision History

Rev.	Issue Date	Revisions	Revised By
--	07/29/09	Initial Issue	F. Ibrahim
B	08/03/09	Corrected description of DFS from "conducted" to "radiated".	A. Zaffar
B1	08/04/09	Corrected typos	A. Zaffar
C	10/06/09	Revised PK power, AV power, PPSD, BE, Harmonics and Conducted Spurious for HT40 modes in all bands in this report. Revised DFS test results for new firmware revision.	F. Ibrahim

TABLE OF CONTENTS

1. ATTESTATION OF TEST RESULTS	6
2. TEST METHODOLOGY	7
3. FACILITIES AND ACCREDITATION	7
4. CALIBRATION AND UNCERTAINTY	7
4.1. MEASURING INSTRUMENT CALIBRATION	7
4.2. SAMPLE CALCULATION	7
4.3. MEASUREMENT UNCERTAINTY	7
5. EQUIPMENT UNDER TEST	8
5.1. DESCRIPTION OF EUT	8
5.2. MAXIMUM OUTPUT POWER	8
5.3. DESCRIPTION OF AVAILABLE ANTENNAS	8
5.4. SOFTWARE AND FIRMWARE	9
5.5. WORST-CASE CONFIGURATION AND MODE	9
5.6. DESCRIPTION OF TEST SETUP	10
6. TEST AND MEASUREMENT EQUIPMENT	12
7. ANTENNA PORT TEST RESULTS	13
7.1. 5.2 GHz BAND CHANNEL TESTS FOR 802.11a MODE	13
7.1.1. 26 dB and 99% BANDWIDTH	13
7.1.2. OUTPUT POWER	16
7.1.3. AVERAGE POWER	20
7.1.4. PEAK POWER SPECTRAL DENSITY	21
7.1.5. PEAK EXCURSION	24
7.1.6. CONDUCTED SPURIOUS EMISSIONS	27
7.2. 5.2 GHz BAND CHANNEL TESTS FOR 802.11n HT20 MODE	30
7.2.1. 99% & 26 dB BANDWIDTH	30
7.2.2. OUTPUT POWER	33
7.2.3. AVERAGE POWER	40
7.2.4. PEAK POWER SPECTRAL DENSITY	41
7.2.5. PEAK EXCURSION	44
7.2.6. CONDUCTED SPURIOUS EMISSIONS	47
7.3. 5.2 GHz BAND CHANNEL TESTS FOR 802.11n HT40 MODE	50
7.3.1. 99% & 26 dB BANDWIDTH	50
7.3.2. OUTPUT POWER	52
7.3.3. AVERAGE POWER	57
7.3.4. PEAK POWER SPECTRAL DENSITY	58
7.3.5. PEAK EXCURSION	60
7.3.6. CONDUCTED SPURIOUS EMISSIONS	62
7.4. 5.3 GHz BAND CHANNEL TESTS FOR 802.11a MODE	64

7.4.1. 26 dB and 99% BANDWIDTH 64
7.4.2. OUTPUT POWER 67
7.4.3. AVERAGE POWER 71
7.4.4. PEAK POWER SPECTRAL DENSITY 72
7.4.5. PEAK EXCURSION 75
7.4.6. CONDUCTED SPURIOUS EMISSIONS..... 78
7.5. 5.3 GHz BAND CHANNEL TESTS FOR 802.11n HT20 MODE 82
7.5.1. 99% & 26 dB BANDWIDTH..... 82
7.5.2. OUTPUT POWER 85
7.5.3. AVERAGE POWER 92
7.5.4. PEAK POWER SPECTRAL DENSITY..... 93
7.5.5. PEAK EXCURSION 96
7.5.6. CONDUCTED SPURIOUS EMISSIONS..... 99
7.6. 5.3 GHz BAND CHANNEL TESTS FOR 802.11n HT40 MODE 103
7.6.1. 99% & 26 dB BANDWIDTH..... 103
7.6.2. OUTPUT POWER 105
7.6.3. AVERAGE POWER 110
7.6.4. PEAK POWER SPECTRAL DENSITY 111
7.6.5. PEAK EXCURSION 113
7.6.6. CONDUCTED SPURIOUS EMISSIONS..... 115
7.7. 5.6 GHz BAND CHANNEL TESTS FOR 802.11a MODE 118
7.7.1. 26 dB and 99% BANDWIDTH 118
7.7.2. OUTPUT POWER 121
7.7.3. AVERAGE POWER 125
7.7.4. PEAK POWER SPECTRAL DENSITY 126
7.7.5. PEAK EXCURSION 129
7.7.6. CONDUCTED SPURIOUS EMISSIONS..... 132
7.8. 5.6 GHz BAND CHANNEL TESTS FOR 802.11n HT20 MODE 136
7.8.1. 99% & 26 dB BANDWIDTH..... 136
7.8.2. OUTPUT POWER 139
7.8.3. AVERAGE POWER 146
7.8.4. PEAK POWER SPECTRAL DENSITY 147
7.8.5. PEAK EXCURSION 150
7.8.6. CONDUCTED SPURIOUS EMISSIONS..... 153
7.9. 5.6 GHz BAND CHANNEL TESTS FOR 802.11n HT40 MODE 157
7.9.1. 99% & 26 dB BANDWIDTH..... 157
7.9.2. OUTPUT POWER 160
7.9.3. AVERAGE POWER 167
7.9.4. PEAK POWER SPECTRAL DENSITY 168
7.9.5. PEAK EXCURSION 171
7.9.6. CONDUCTED SPURIOUS EMISSIONS..... 174
7.10. RECEIVER CONDUCTED SPURIOUS EMISSIONS 177
8. RADIATED TEST RESULTS 181
8.1. LIMITS AND PROCEDURE 181
8.2. TRANSMITTER ABOVE 1 GHz 182
8.2.1. 802.11a MODE IN 5.2 GHz BAND 182
8.2.2. 802.11n HT20 MODE IN 5.2 GHz BAND 185

8.2.3. 802.11n HT40 MODE IN 5.2 GHz BAND 189
8.2.4. 802.11a MODE IN 5.3 GHz BAND 193
8.2.5. 802.11n HT20 MODE IN 5.3 GHz BAND 195
8.2.6. 802.11n HT40 MODE IN 5.3 GHz BAND 199
8.2.7. 802.11a MODE IN THE 5.6 GHz BAND 201
8.2.8. 802.11n HT20 MODE IN THE 5.6 GHz BAND 205
8.2.9. 802.11n HT40 MODE IN THE 5.6 GHz BAND 209
8.3. WORST-CASE BELOW 1 GHz 213
9. AC POWER LINE CONDUCTED EMISSIONS 215
10. DYNAMIC FREQUENCY SELECTION 219
10.1. OVERVIEW 219
10.1.1. LIMITS 219
10.1.2. TEST AND MEASUREMENT SYSTEM 223
10.1.3. SETUP OF EUT 226
10.1.4. DESCRIPTION OF EUT 227
10.2. 20 MHz BANDWIDTH RESULTS 228
10.2.1. TEST CHANNEL 228
10.2.2. PLOTS OF RADAR WAVEFORM AND WLAN TRAFFIC 228
10.2.3. MOVE AND CLOSING TIME 230
10.3. 40 MHz BANDWIDTH RESULTS 235
10.3.1. TEST CHANNEL 235
10.3.2. PLOTS OF RADAR WAVEFORM AND WLAN TRAFFIC 235
10.3.3. MOVE AND CLOSING TIME 237
10.3.4. SLAVE NON-OCCUPANCY 242
11. MAXIMUM PERMISSIBLE EXPOSURE 243
12. SETUP PHOTOS 247

1. ATTESTATION OF TEST RESULTS

COMPANY NAME: QUALCOMM INC.
3165 KIFER RD
SANTA CLARA, CA 95051
U.S.A.

EUT DESCRIPTION: DC544D_1 PCIe DAUGHTER CARD FOR 2.4 / 5 GHz CLIENT APPLICATIONS

MODEL: 65-VN780-P1

SERIAL NUMBER: 7916 for Antenna Port, 7929 for Radiated Emission, and 02324 for DFS

DATE TESTED: JUNE 24 – JULY 23, 2009

APPLICABLE STANDARDS	
STANDARD	TEST RESULTS
CFR 47 Part 15 Subpart E	Pass
INDUSTRY CANADA RSS-210 Issue 7 Annex 9	Pass
INDUSTRY CANADA RSS-GEN Issue 2	Pass

Compliance Certification Services, Inc. (CCS) tested the above equipment in accordance with the requirements set forth in the above standards. All indications of Pass/Fail in this report are opinions expressed by CCS based on interpretations and/or observations of test results. Measurement Uncertainties were not taken into account and are published for informational purposes only. The test results show that the equipment tested is capable of demonstrating compliance with the requirements as documented in this report.

Note: The results documented in this report apply only to the tested sample, under the conditions and modes of operation as described herein. This document may not be altered or revised in any way unless done so by CCS and all revisions are duly noted in the revisions section. Any alteration of this document not carried out by CCS will constitute fraud and shall nullify the document. This report must not be used by the client to claim product certification, approval, or endorsement by NVLAP, NIST, any agency of the Federal Government, or any agency of any government.

Approved & Released For CCS By:

Tested By:



FRANK IBRAHIM
EMC SUPERVISOR
COMPLIANCE CERTIFICATION SERVICES

VIEN TRAN
EMC ENGINEER
COMPLIANCE CERTIFICATION SERVICES

2. TEST METHODOLOGY

The tests documented in this report were performed in accordance with ANSI C63.4-2003, FCC CFR 47 Part 2, FCC CFR 47 Part 15, FCC 06-96, RSS-GEN Issue 2, and RSS-210 Issue 7.

3. FACILITIES AND ACCREDITATION

The test sites and measurement facilities used to collect data are located at 47173 Benicia Street, Fremont, California, USA.

CCS is accredited by NVLAP, Laboratory Code 200065-0. The full scope of accreditation can be viewed at <http://www.ccsemc.com>.

4. CALIBRATION AND UNCERTAINTY

4.1. MEASURING INSTRUMENT CALIBRATION

The measuring equipment utilized to perform the tests documented in this report has been calibrated in accordance with the manufacturer's recommendations, and is traceable to recognized national standards.

4.2. SAMPLE CALCULATION

Where relevant, the following sample calculation is provided:

$$\begin{aligned} \text{Field Strength (dBuV/m)} &= \text{Measured Voltage (dBuV)} + \text{Antenna Factor (dB/m)} + \\ &\text{Cable Loss (dB)} - \text{Preamp Gain (dB)} \\ 36.5 \text{ dBuV} + 18.7 \text{ dB/m} + 0.6 \text{ dB} - 26.9 \text{ dB} &= 28.9 \text{ dBuV/m} \end{aligned}$$

4.3. MEASUREMENT UNCERTAINTY

Where relevant, the following measurement uncertainty levels have been estimated for tests performed on the apparatus:

PARAMETER	UNCERTAINTY
Conducted Disturbance, 0.15 to 30 MHz	3.52 dB
Radiated Disturbance, 30 to 1000 MHz	4.94 dB

Uncertainty figures are valid to a confidence level of 95%.

5. EQUIPMENT UNDER TEST

5.1. DESCRIPTION OF EUT

The EUT is an 802.11a/b/g/n WLAN transceiver module in a PCI form factor, for 2.4 / 5 GHz client applications. It is equipped with four identical transmitter / receiver chains.

The radio module is manufactured by Qualcomm, Inc.

5.2. MAXIMUM OUTPUT POWER

The transmitter has a maximum peak conducted output power as follows:

Frequency Range (MHz)	Mode	Output Power (dBm)	Output Power (mW)
5.2 GHz BAND			
5180 - 5240	802.11a	12.18	16.52
5180 - 5240	802.11n HT20	13.23	21.04
5190 - 5230	802.11n HT40	16.67	46.45
5.3 GHz BAND			
5260 - 5320	802.11a	19.15	82.22
5260 - 5320	802.11n HT20	20.65	116.14
5270 - 5310	802.11n HT40	23.24	210.86
5.6 GHz BAND			
5500 - 5700	802.11a	20.77	119.40
5500 - 5700	802.11n HT20	20.24	105.68
5510 - 5670	802.11n HT40	23.65	231.74

5.3. DESCRIPTION OF AVAILABLE ANTENNAS

The radio utilizes a dual band omni monopole (4 identical) antenna, each with a maximum gain of 3 dBi in the 5 GHz bands.

For the 802.11a legacy mode only two chains are transmitting, therefore the effective legacy antenna gain is:

Antenna Gain (dBi)	10 Log (# Tx Chains) (dB)	Effective Legacy Gain (dBi)
3	3.01	6.01

5.4. SOFTWARE AND FIRMWARE

The EUT driver software installed during testing was Qualcomm, rev. 0.0.500.5.

The test utility software used during emissions testing was PTT Gui, rev. 5.1.

5.5. WORST-CASE CONFIGURATION AND MODE

The EUT was tested as an external module installed in a test jig board connected to a host Laptop PC.

Worst-Case data rates were utilized from preliminary testing of the Chipset, worst-case data rates used during the testing are as follows:

802.11a Mode (20 MHz BW operation): 6 Mbps, OFDM.

802.11n MIMO HT20 Mode: MCS31, 260 Mbps, 4 Spatial Streams.

802.11n MIMO HT40 Mode: MCS31, 540 Mbps, 4 Spatial Streams.

Worst-case mode and channel used for 30-1000 MHz radiated and power line conducted emissions was the mode and channel with the highest output power, that was determined to be 11n HT40, high channel.

For bandwidth measurement preliminary testing showed that there is no significant difference among different chains, so the measurements were performed using Chain 0.

For conducted spurious measurement preliminary testing showed that combiner is worst-case compared to individual chains; therefore final measurements were performed using combiner for all channels and modes.

For PPSD measurement preliminary testing showed that combiner is worst-case compared to individual chains; therefore final measurements were performed using combiner for all channels and modes.

For Radiated Band Edge measurements preliminary testing showed that the worst case was vertical polarization, so final measurements were performed with vertical polarization.

5.6. DESCRIPTION OF TEST SETUP

SUPPORT EQUIPMENT

PERIPHERAL SUPPORT EQUIPMENT LIST				
Description	Manufacturer	Model	Serial Number	FCC ID
Laptop	IBM	T43 ThinkPad	L3-XDLXW06/02	DoC
AC Adapter	IBM	08K8204	11S08K8204Z1Z9	DoC
DC Power Supply	Tektronic	PS2521G	N/A	N/A
DC Power Supply	HP	336108	KR24104150	N/A
Extender PCI	ALLION	V1 EC-PEM V1.0	A073	N/A

I/O CABLES

I/O CABLE LIST						
Cable No.	Port	# of Identical Ports	Connecto Type	Cable Type	Cable Length	Remarks
1	AC	2	US115	Un-shielded	1.5 m	For laptop
2	DC	1	DC	Un-shielded	1.5 m	For laptop
3	DC	1	Cable	Un-shielded	1.0 m	For EUT
4	Ribbon	1	Ribbon	Un-shielded	.4 m	Test Fixture

TEST SETUP

The EUT is connected to a host laptop computer via a test fixture during the tests. Test software exercised the radio card.

SETUP DIAGRAM FOR TESTS

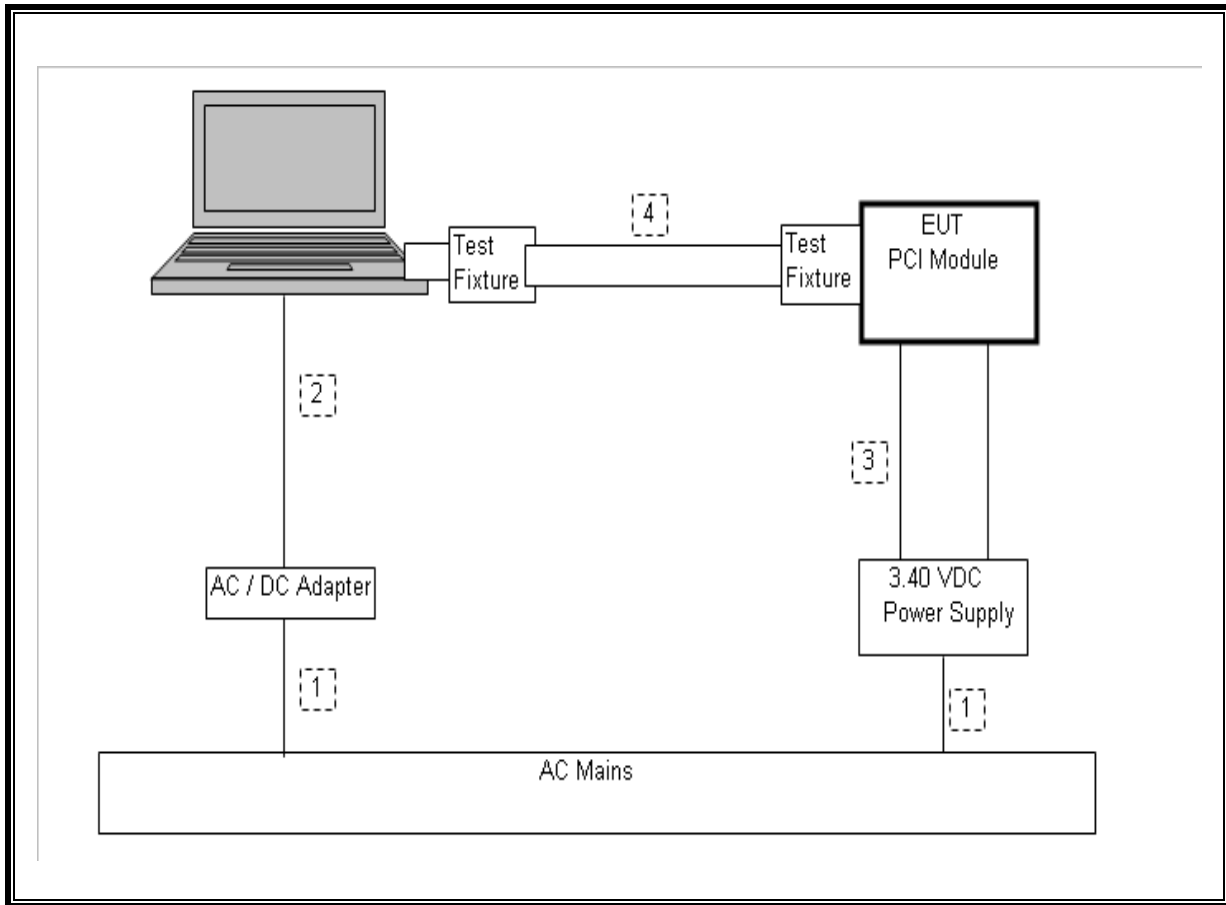

6. TEST AND MEASUREMENT EQUIPMENT

The following test and measurement equipment was utilized for the tests documented in this report:

TEST EQUIPMENT LIST					
Description	Manufacturer	Model	Asset	Cal Date	Cal Due
Spectrum Analyzer, 44 GHz	Agilent / HP	E4446A	C01069	01/05/09	01/05/10
Antenna, Bilog, 2 GHz	Sunol Sciences	JB1	C01011	01/14/09	01/14/10
Antenna, Horn, 18 GHz	EMCO	3115	C00945	04/22/09	04/22/10
Antenna, Horn, 26.5 GHz	ARA	MVH-1826/B	C00589	09/29/08	11/28/09
Antenna, Horn, 40 GHz	ARA	MVH-2640B	C00981	05/21/09	05/21/10
Preamplifier, 40 GHz	Miteq	NSP4000-SP2	C00990	10/11/08	10/11/09
Preamplifier, 1300 MHz	Agilent / HP	8447D	C00885	03/31/09	03/31/10
Preamplifier, 1-26GHz	Agilent / HP	8449B	C01052	08/05/08	08/05/09
Peak Power Meter	Boonton	4541	C01186	01/19/09	01/19/10
Peak Power Sensor	Boonton	4541	C01189	01/15/09	01/15/10
LISN, 30 MHz	FCC	LISN-50/250-25-2	N02625	10/29/08	10/29/09
EMI Test Receiver, 30 MHz	R & S	ESHS 20	N02396	02/06/08	08/06/09

7. ANTENNA PORT TEST RESULTS

7.1. 5.2 GHz BAND CHANNEL TESTS FOR 802.11a MODE

7.1.1. 26 dB and 99% BANDWIDTH

LIMITS

None; for reporting purposes only.

TEST PROCEDURE

The transmitter outputs are connected to the spectrum analyzer via a combiner. The RBW is set to 1% to 3% of the measured bandwidth. The VBW is set to 3 times the RBW. The sweep time is coupled. The spectrum analyzer internal bandwidth function is utilized.

RESULTS

Channel	Frequency (MHz)	26 dB Bandwidth (MHz)	99% Bandwidth (MHz)
Low	5180	18.0690	16.5410
Middle	5200	18.2250	16.4197
High	5240	19.5230	16.3303

26 dB and 99% BANDWIDTH

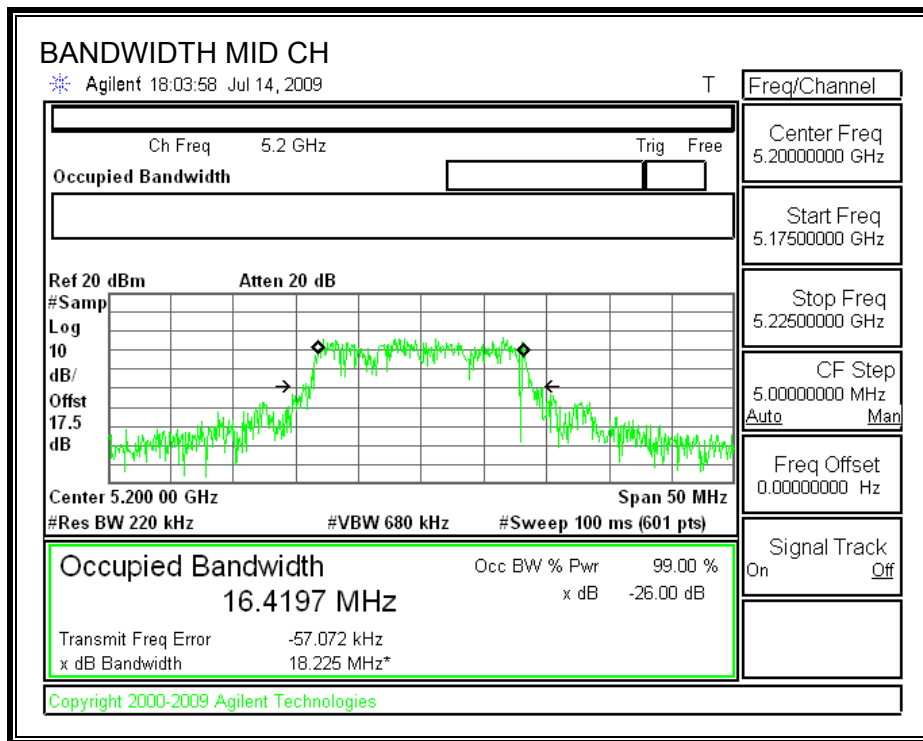
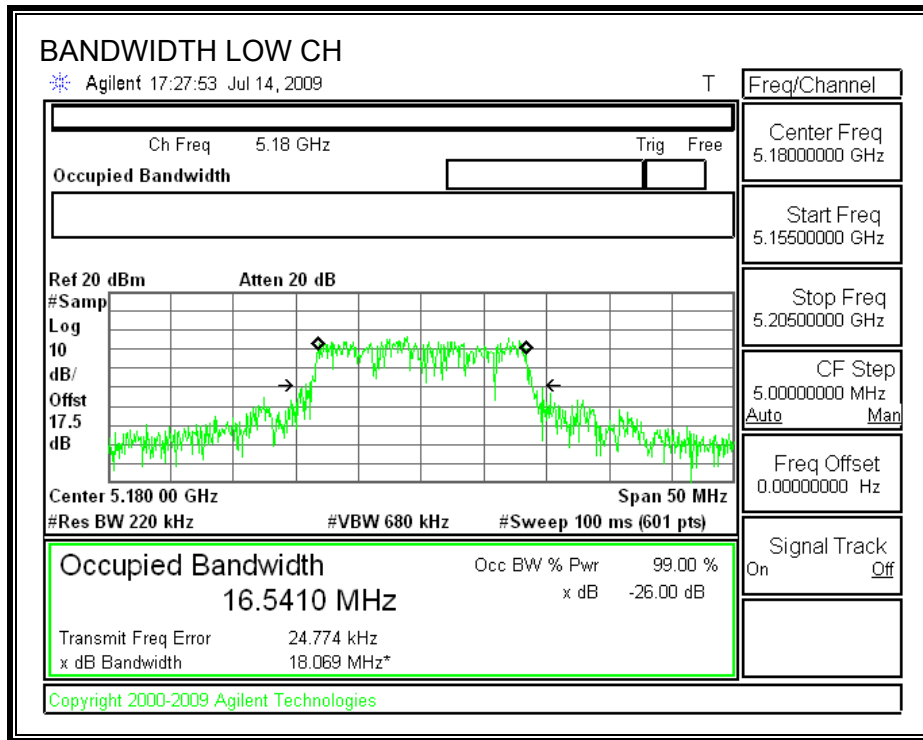

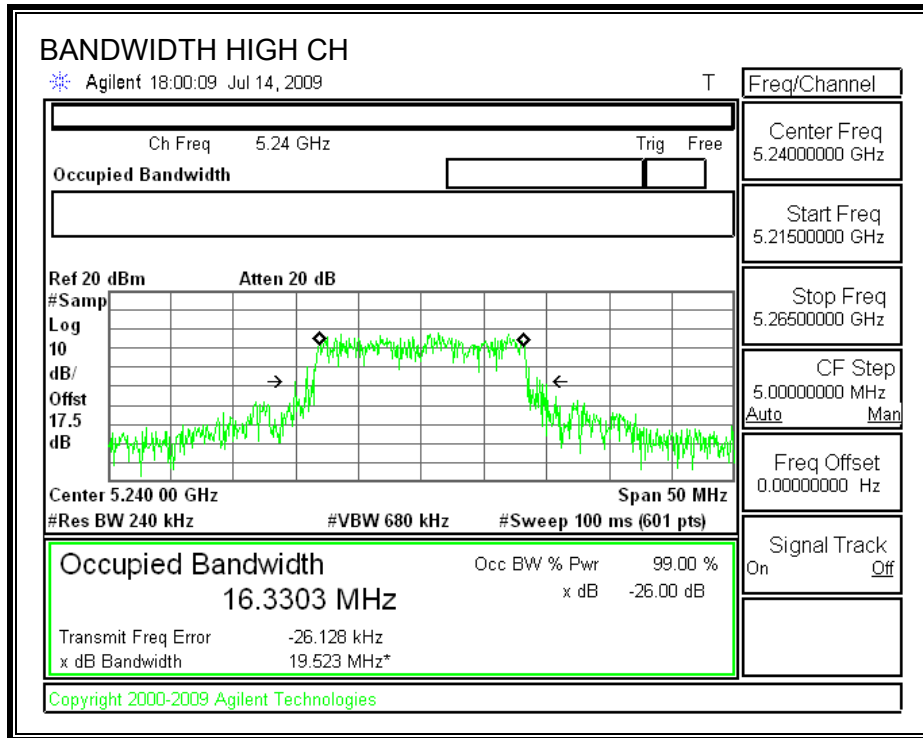

7.1.2. OUTPUT POWER

LIMITS

FCC §15.407 (a) (1)
 IC RSS-210 A9.2 (1)

Antenna gain of Chain 1 = antenna gain of Chain 2.

Antenna Gain (dBi)	10 Log (# Tx Chains) (dB)	Effective Legacy Gain (dBi)
3	3.01	6.01

For the 5.15-5.25 GHz band, the maximum conducted output power over the frequency band of operation shall not exceed the lesser of 50 mW or 4 dBm + 10 log B, where B is the 26-dB emission bandwidth in MHz. If transmitting antennas of directional gain greater than 6 dBi are used, both the peak transmit power and the peak power spectral density shall be reduced by the amount in dB that the directional gain of the antenna exceeds 6 dBi.

TEST PROCEDURE

The test is performed in accordance with FCC Public Notice: APPENDIX A Guidelines for Assessing Unlicensed National Information Infrastructure (U-NII) Devices – Part 15, Subpart E, August 2002.

The transmitter output operates continuously therefore Method # 1 is used.

RESULTS

Limit

Channel	Freq (MHz)	Fixed Limit (dBm)	B (MHz)	4 + 10 Log B Limit (dBm)	Effective Antenna Gain (dBi)	Limit (dBm)
Low	5180	17	18.069	16.57	6.01	16.56
Mid	5200	17	18.225	16.61	6.01	16.60
High	5240	17	19.523	16.91	6.01	16.90

Individual Chain Results

Channel	Freq (MHz)	Chain 0 Power (dBm)	Chain 1 Power (dBm)	Total Power (dBm)	Limit (dBm)	Margin (dB)
Low	5180	9.12	9.22	12.18	16.56	-4.38
Mid	5200	9.15	8.96	12.07	16.60	-4.53
High	5240	9.18	9.13	12.17	16.90	-4.73

OUTPUT POWER, LOW CHANNEL

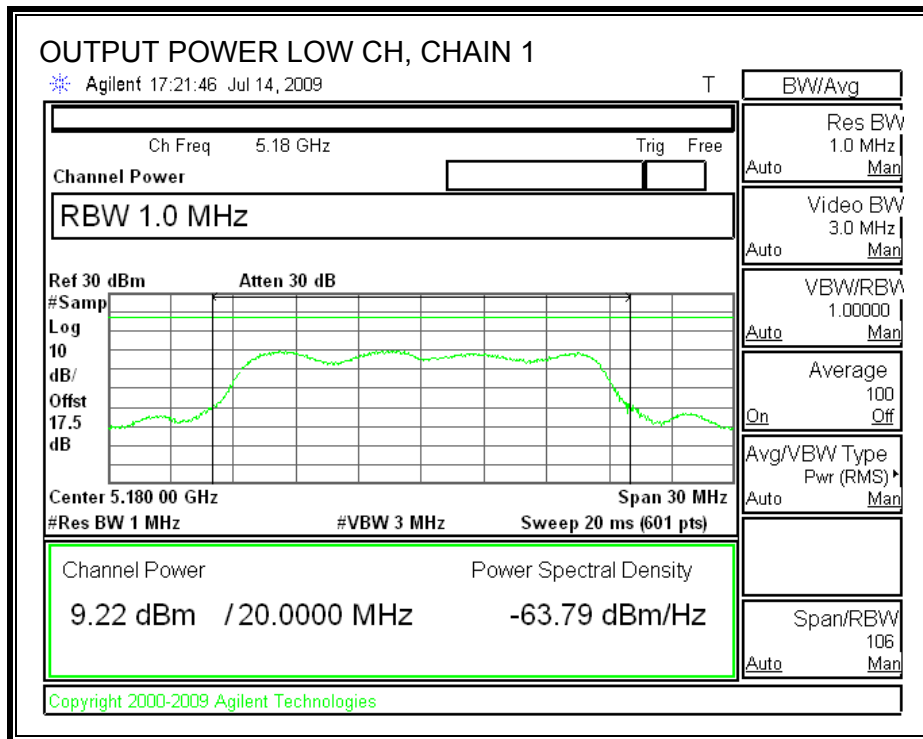
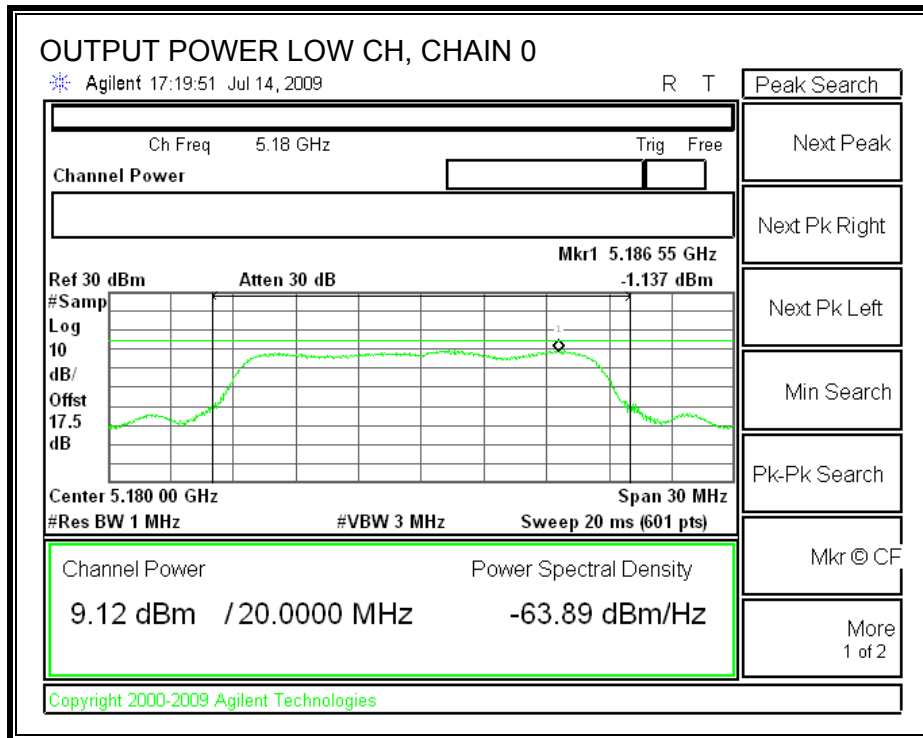

OUTPUT POWER, MID CHANNEL

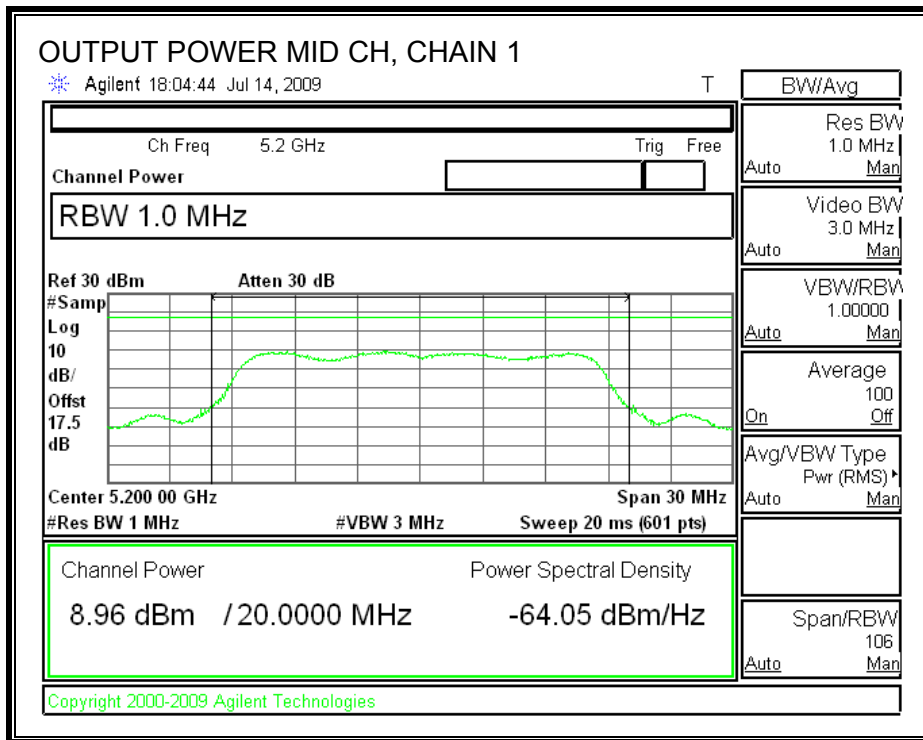
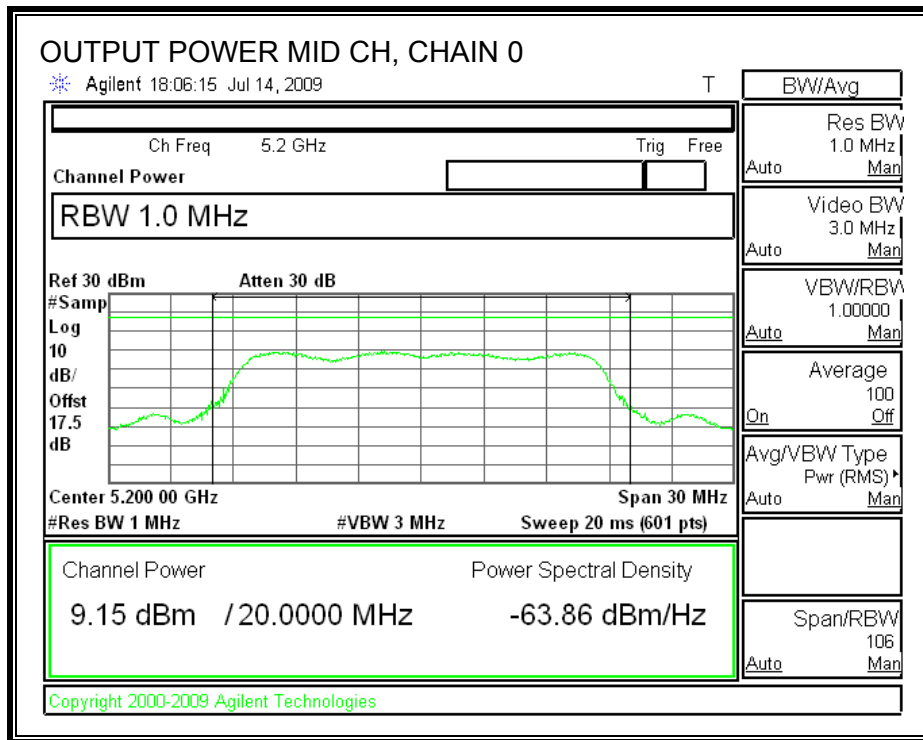

OUTPUT POWER, HIGH CHANNEL

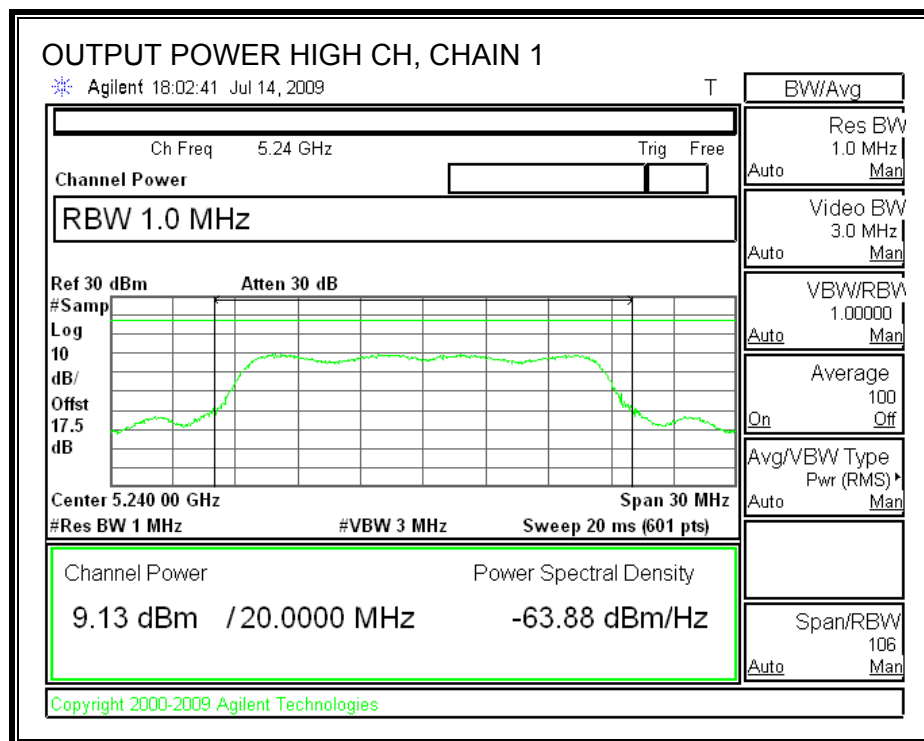
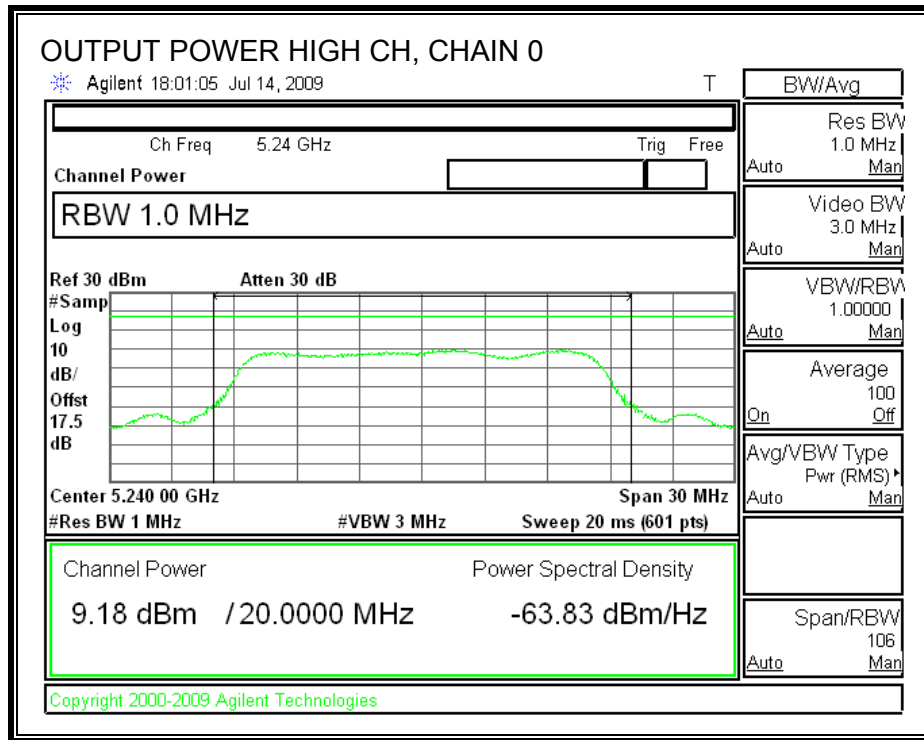

7.1.3. AVERAGE POWER

LIMITS

None; for reporting purposes only.

TEST PROCEDURE

The transmitter output is connected to a power meter.

RESULTS

The cable assembly insertion loss of 11.3 dB (including 10 dB pad and 1.3 dB cable) was entered as an offset in the power meter to allow for direct reading of power.

Channel	Frequency (MHz)	Chain 1 Power (dBm)	Chain 2 Power (dBm)	Total Power (dBm)
Low	5180	9.12	9.08	12.11
Middle	5200	9.21	9.05	12.14
High	5240	9.16	8.99	12.09

7.1.4. PEAK POWER SPECTRAL DENSITY

LIMITS

FCC §15.407 (a) (1)

IC RSS-210 A9.2 (1)

Use this table if antenna gain for Chain 1 = antenna gain for Chain 2

Antenna Gain (dBi)	10 Log (# Tx Chains) (dB)	Effective Legacy Gain (dBi)
3	3.01	6.01

For the 5.15-5.25 GHz band, the peak power spectral density shall not exceed 4 dBm in any 1 MHz band. If transmitting antennas of directional gain greater than 6 dBi are used, both the peak transmit power and the peak power spectral density shall be reduced by the amount in dB that the directional gain of the antenna exceeds 6 dBi.

The maximum effective antenna gain is 6.01 dBi, therefore the limit is 3.99 dBm.

TEST PROCEDURE

The test is performed in accordance with FCC Public Notice: APPENDIX A Guidelines for Assessing Unlicensed National Information Infrastructure (U-NII) Devices – Part 15, Subpart E, August 2002. PPSD method #2 was used.

RESULTS

Channel	Frequency (MHz)	PPSD With Combiner (dBm)	Limit (dBm)	Margin (dB)
Low	5180	3.86	3.99	-0.13
Middle	5200	3.91	3.99	-0.08
High	5240	3.82	3.99	-0.18

POWER SPECTRAL DENSITY WITH COMBINER

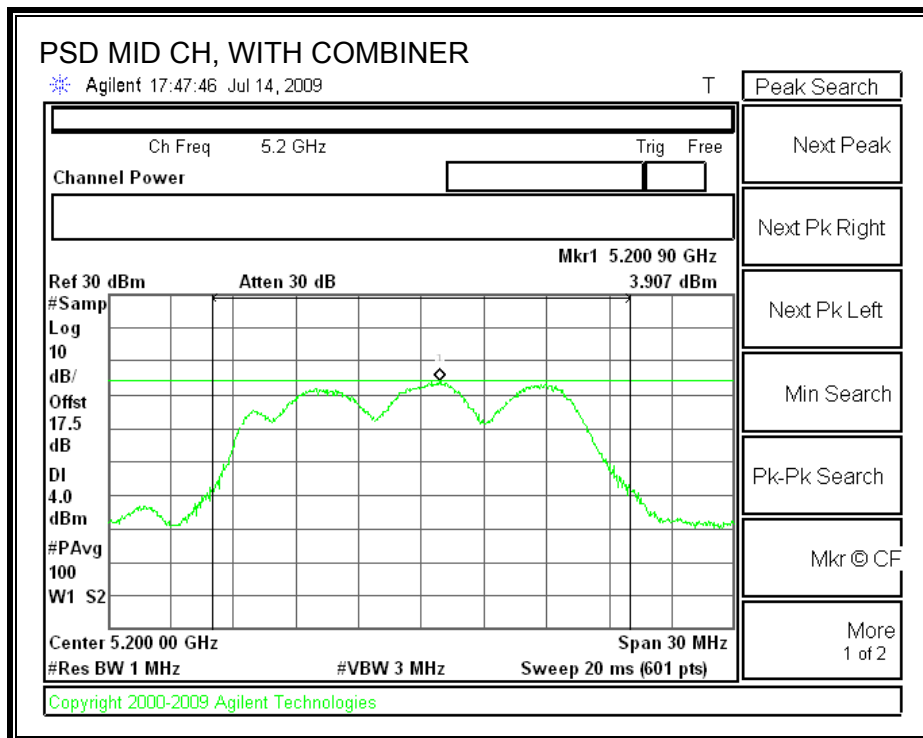
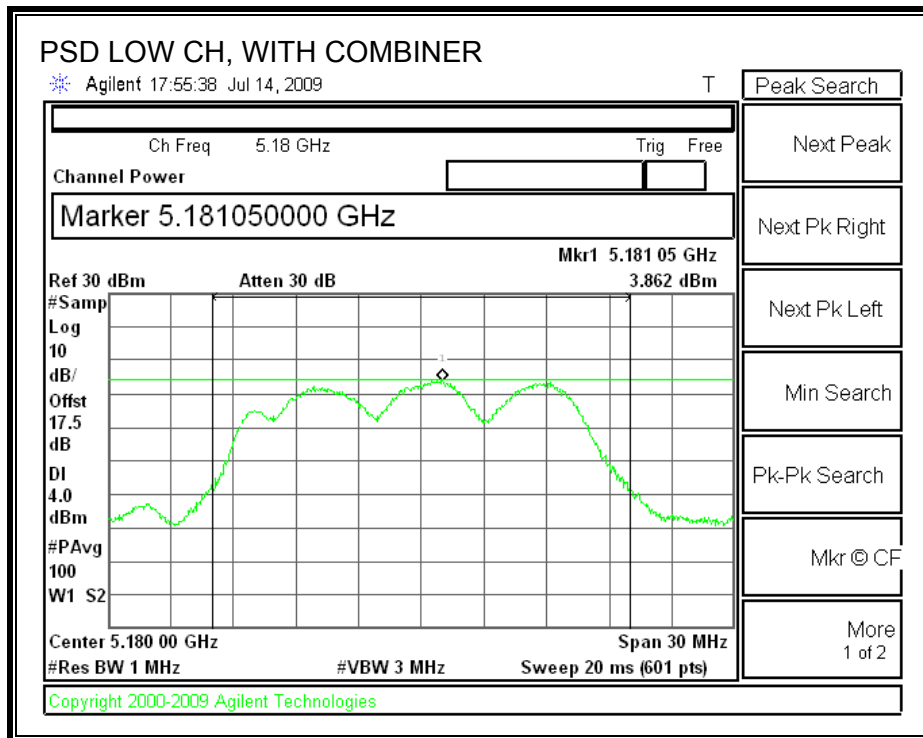

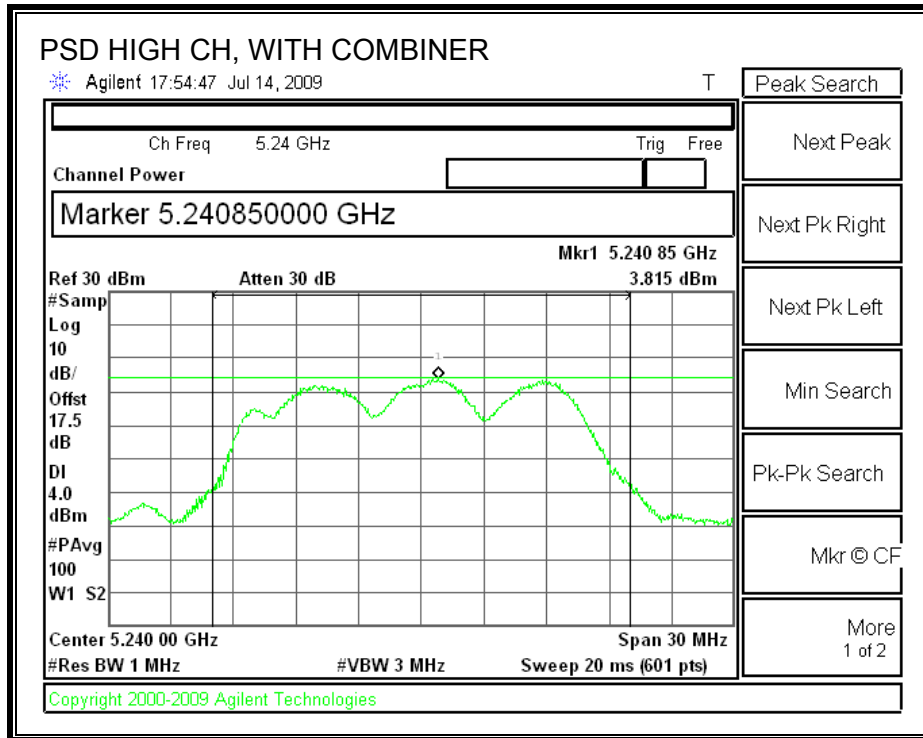

7.1.5. PEAK EXCURSION

LIMITS

FCC §15.407 (a) (6)

The ratio of the peak excursion of the modulation envelope (measured using a peak hold function) to the peak transmit power (measured as specified above) shall not exceed 13 dB across any 1 MHz bandwidth or the emission bandwidth whichever is less.

TEST PROCEDURE

The transmitter outputs are connected to the spectrum analyzer via a combiner.

The test is performed in accordance with FCC Public Notice: APPENDIX A Guidelines for Assessing Unlicensed National Information Infrastructure (U-NII) Devices – Part 15, Subpart E, August 2002.

Since Method # 1 was used for peak power measurements, Method # 1 settings are used for the second PPSD trace.

RESULTS

Channel	Frequency (MHz)	Peak Excursion (dB)	Limit (dB)	Margin (dB)
Low	5180	9.69	13	-3.31
Middle	5200	9.45	13	-3.55
High	5240	10.20	13	-2.80

PEAK EXCURSION

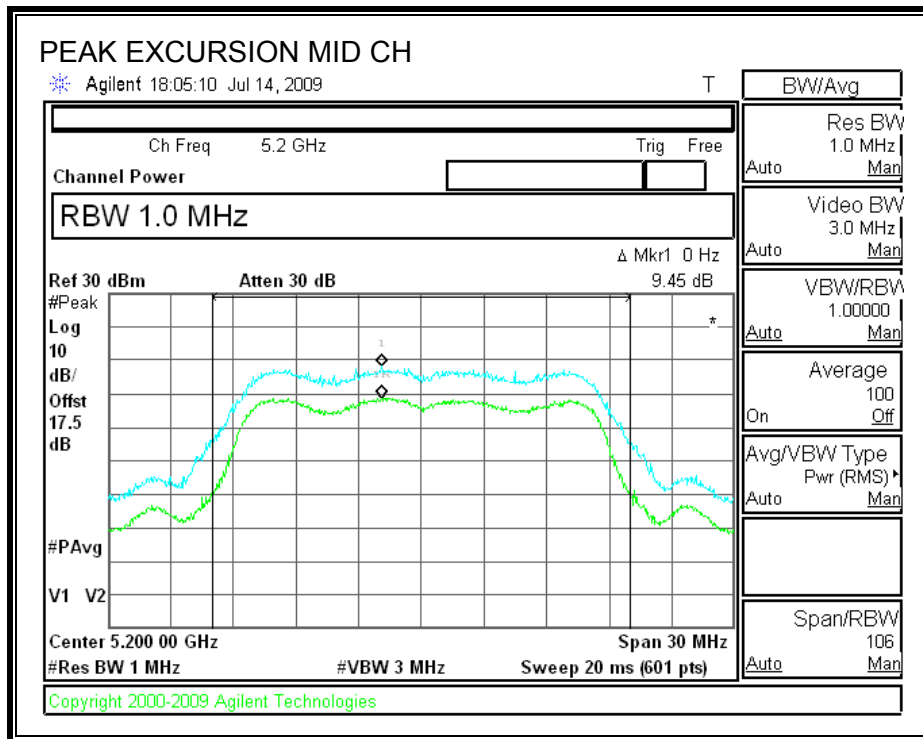
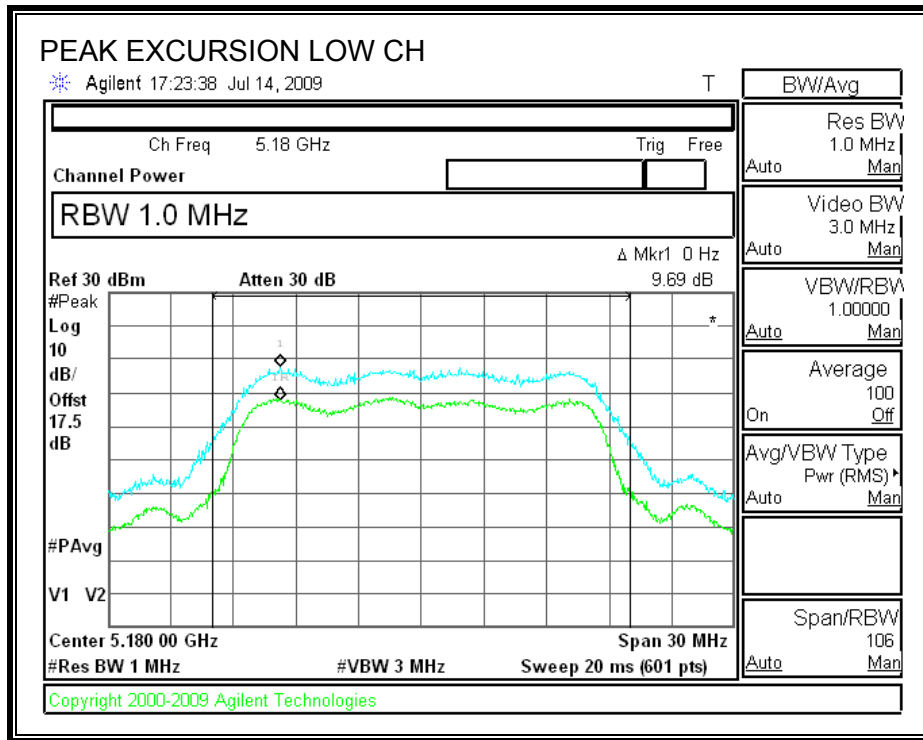

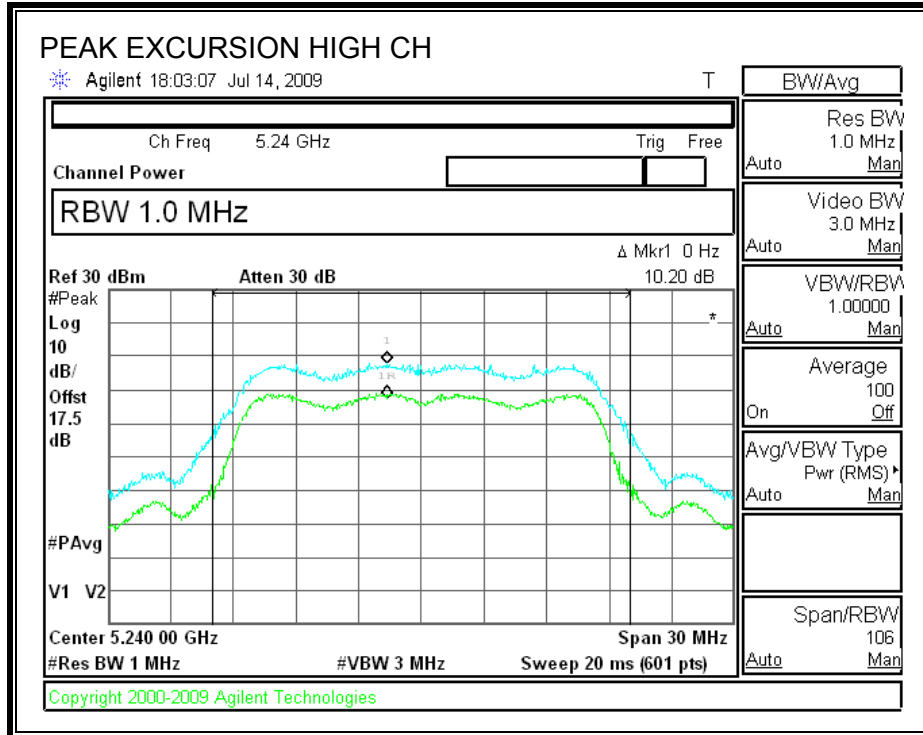

7.1.6. CONDUCTED SPURIOUS EMISSIONS

LIMITS

FCC §15.407 (b) (1)

IC RSS-210 A9.3 (1)

For transmitters operating in the 5.15-5.25 GHz band: all emissions outside of the 5.15-5.35 GHz band shall not exceed an EIRP of -27 dBm / MHz.

TEST PROCEDURE

Conducted RF measurements of the transmitter output are made to confirm that the EUT antenna port conducted emissions meet the specified limit and to identify any spurious signals that require further investigation or measurements on the radiated emissions site.

The transmitter output is connected to the spectrum analyzer. The resolution bandwidth is set to 1 MHz. The video bandwidth is set to 1 MHz. Peak detection measurements are compared to EIRP limit, adjusted for the maximum antenna gain.

Measurements are made over the 30 MHz to 40 GHz range with the transmitter set to the lowest, middle, and highest channels.

SPURIOUS EMISSIONS WITH COMBINER

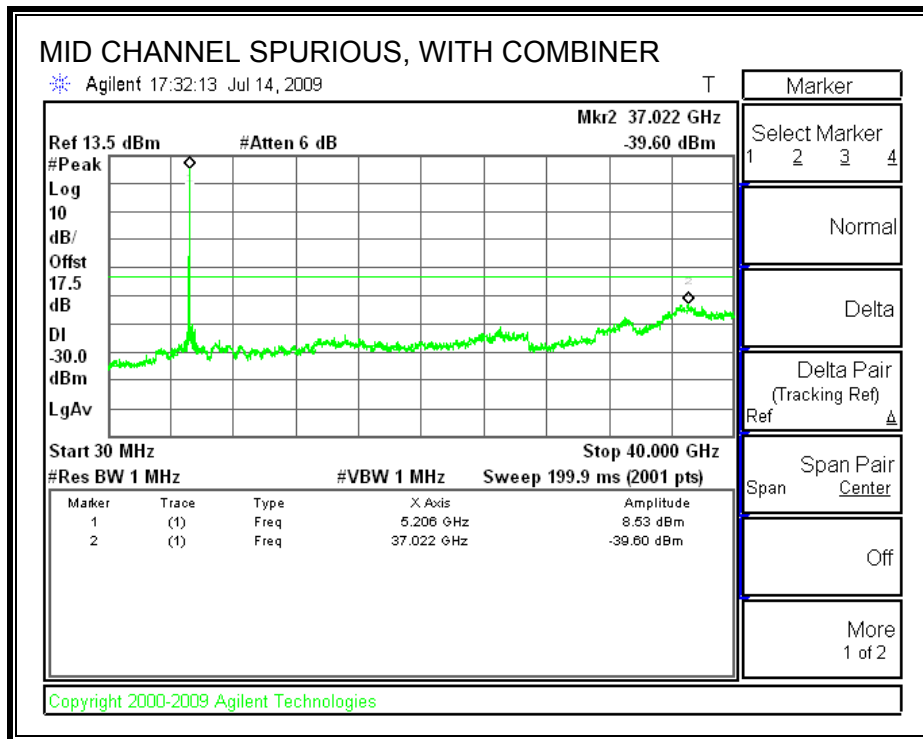
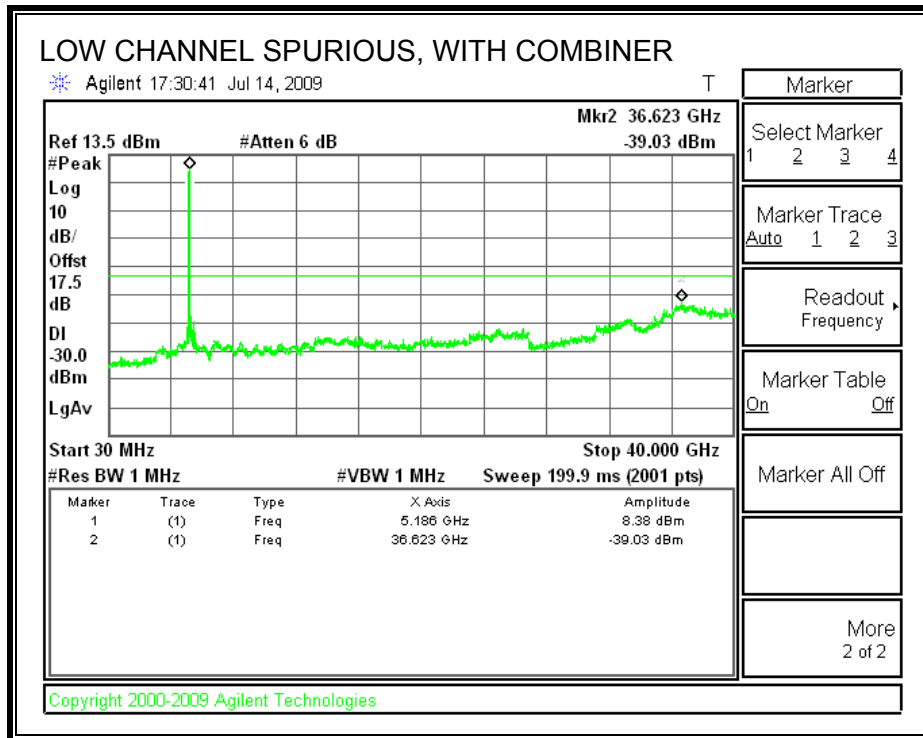

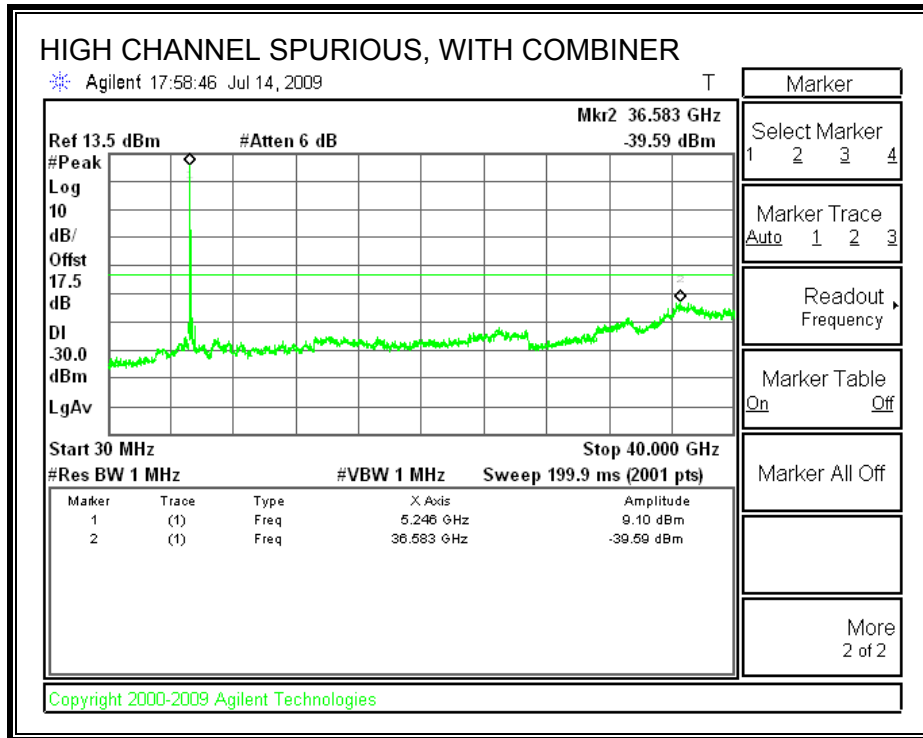

7.2. 5.2 GHz BAND CHANNEL TESTS FOR 802.11n HT20 MODE

7.2.1. 99% & 26 dB BANDWIDTH

LIMITS

None; for reporting purposes only.

TEST PROCEDURE

The transmitter output is connected to the spectrum analyzer. The RBW is set to 1% to 3% of the bandwidth. The VBW is set to 3 times the RBW. The sweep time is coupled. The spectrum analyzer internal bandwidth measurement function is utilized.

RESULTS

Channel	Frequency (MHz)	99% OBW (MHz)	26 dB BW (MHz)
Low	5180	17.4954	18.700
Middle	5200	17.5643	18.757
High	5240	17.5132	18.413

99% & 26 dB BANDWIDTH

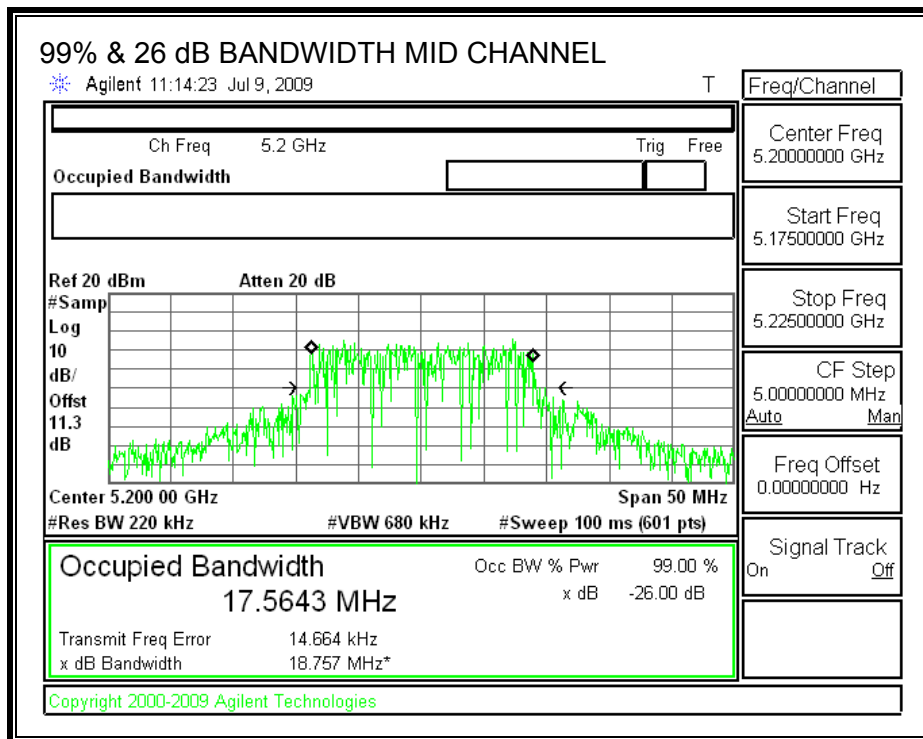
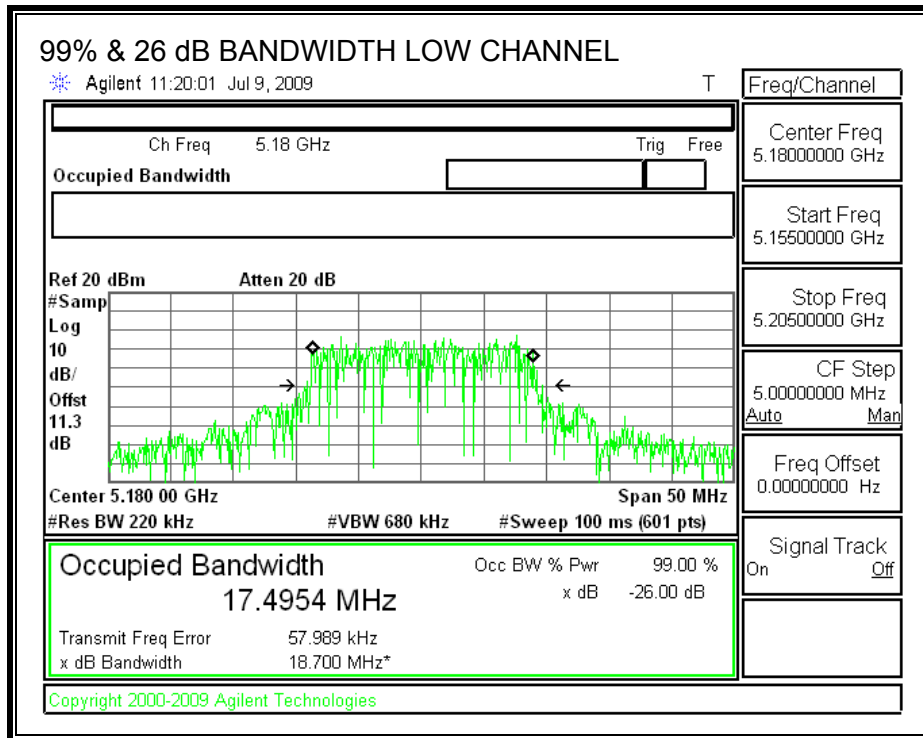

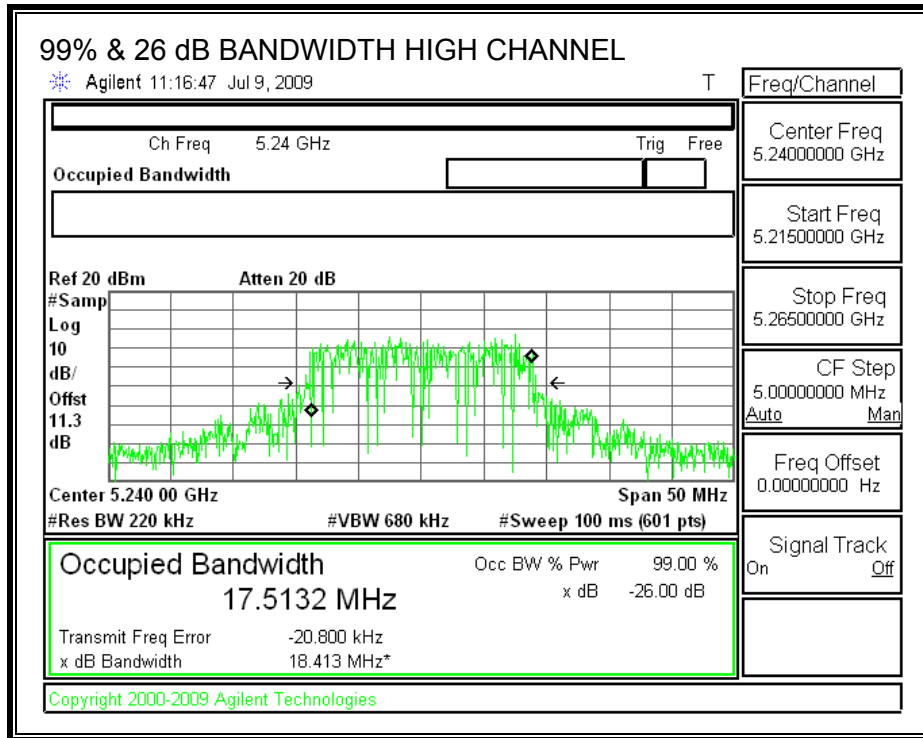

7.2.2. OUTPUT POWER

LIMITS

FCC §15.407 (a) (2)
 IC RSS-210 A9.2 (2)

For the 5.15-5.25 GHz band, the maximum conducted output power over the frequency band of operation shall not exceed the lesser of 50 mW or 4 dBm + 10 log B, where B is the 26-dB emission bandwidth in MHz. If transmitting antennas of directional gain greater than 6 dBi are used, both the peak transmit power and the peak power spectral density shall be reduced by the amount in dB that the directional gain of the antenna exceeds 6 dBi.

TEST PROCEDURE

The test is performed in accordance with FCC Public Notice: APPENDIX A Guidelines for Assessing Unlicensed National Information Infrastructure (U-NII) Devices – Part 15, Subpart E, August 2002.

The transmitter output operates continuously therefore Method # 1 is used.

RESULTS

Limit

Channel	Freq (MHz)	Fixed Limit (dBm)	B (MHz)	4 + 10 Log B Limit (dBm)	Antenna Gain (dBi)	Limit (dBm)
Low	5180	17	18.700	16.72	3	16.72
Mid	5200	17	18.757	16.73	3	16.73
High	5240	17	18.413	16.65	3	16.65

Individual Chain Results

Channel	Freq (MHz)	Chain 0 Power (dBm)	Chain 1 Power (dBm)	Chain 2 Power (dBm)	Chain 3 Power (dBm)	Total Power (dBm)	Limit (dBm)	Margin (dB)
Low	5180	7.17	7.03	7.07	7.23	13.15	16.72	-3.57
Mid	5200	7.16	7.17	7.22	7.28	13.23	16.73	-3.50
High	5240	7.16	7.14	7.18	7.28	13.21	16.65	-3.44

OUTPUT POWER, LOW CHANNEL

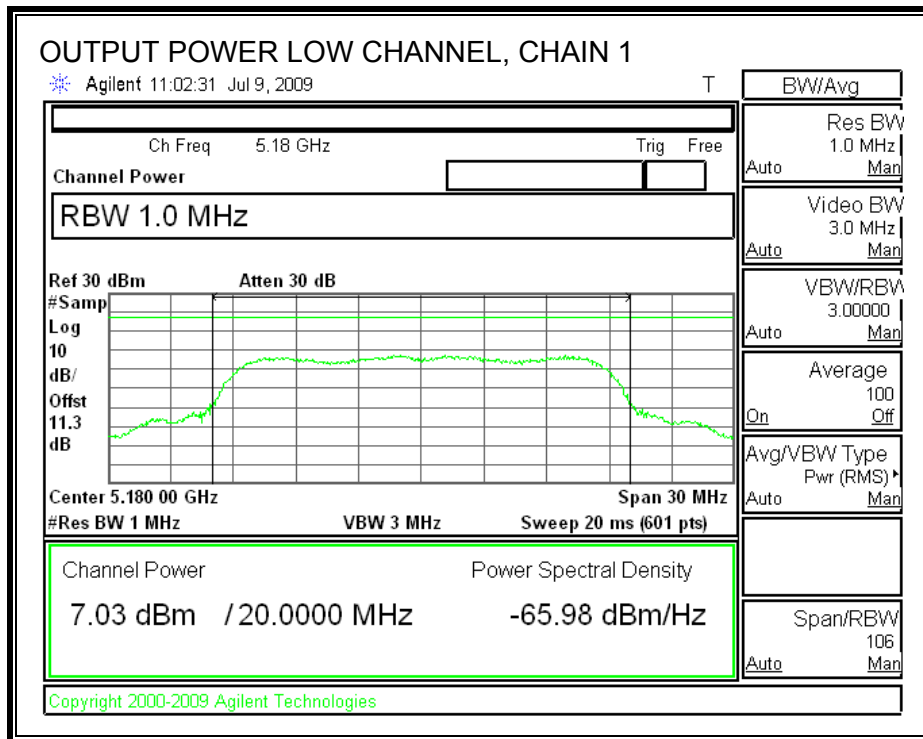
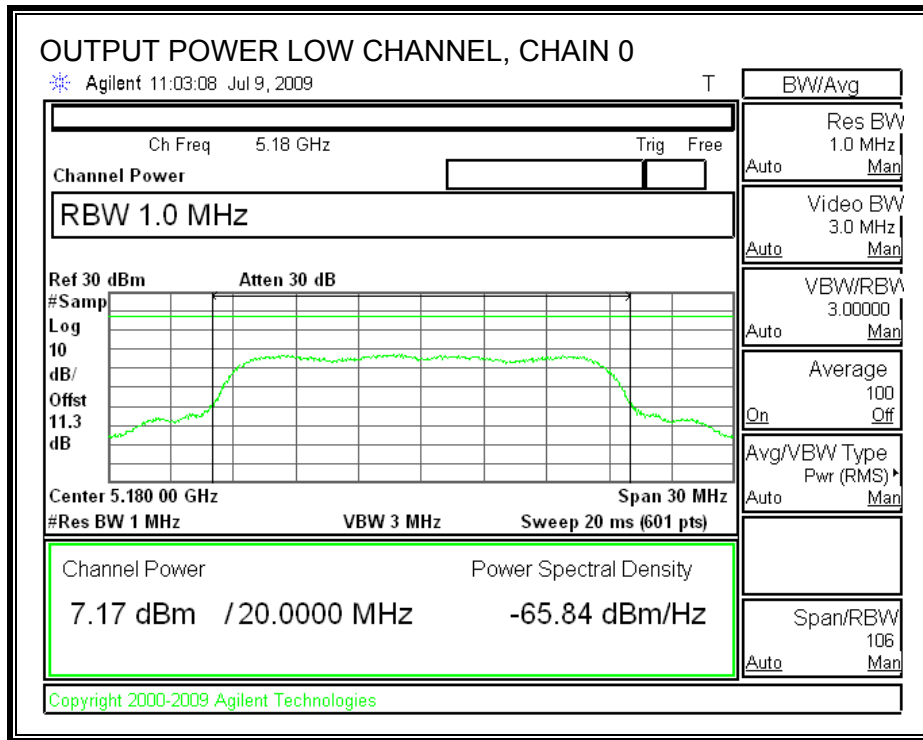

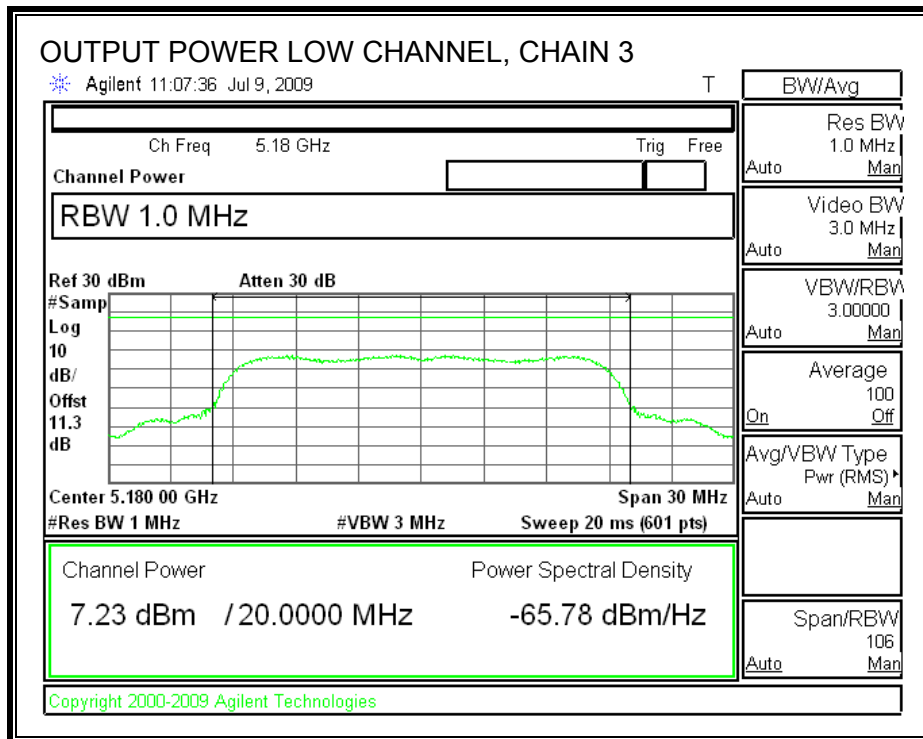
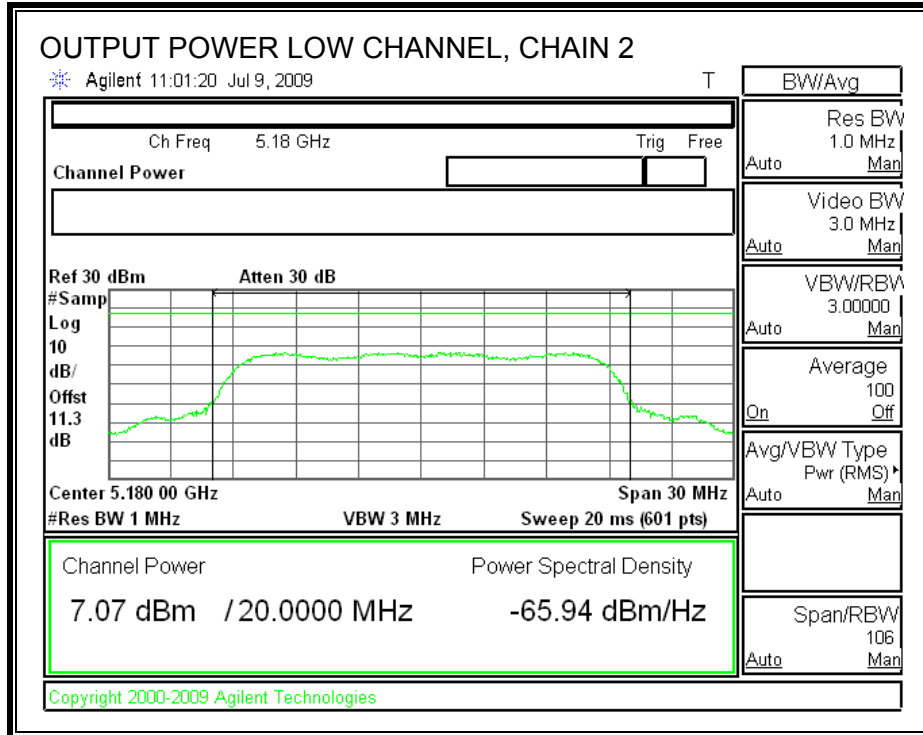

OUTPUT POWER, MID CHANNEL

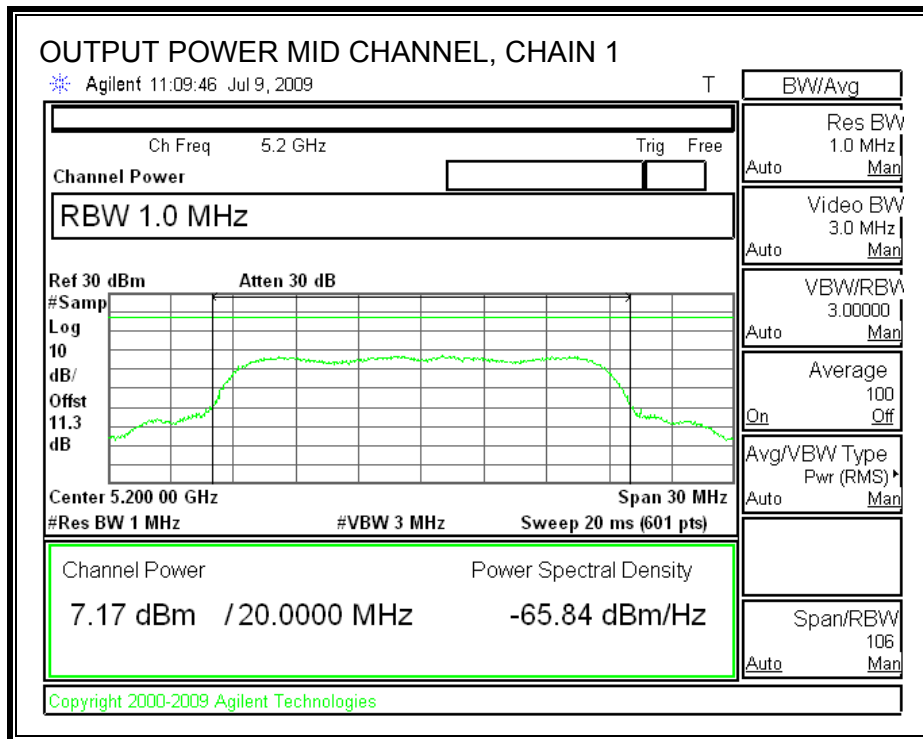
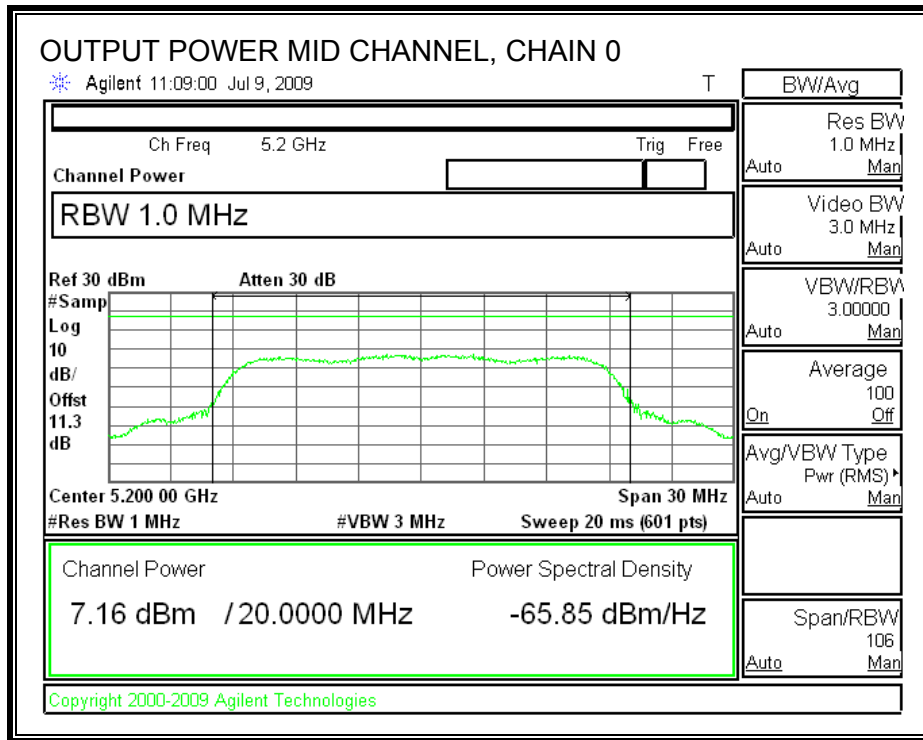

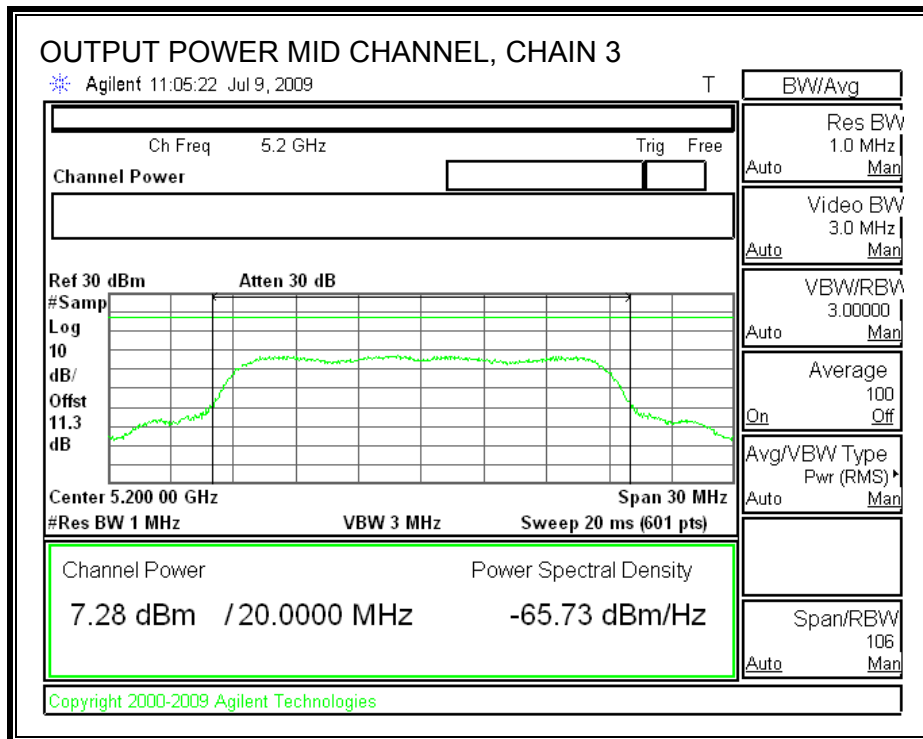
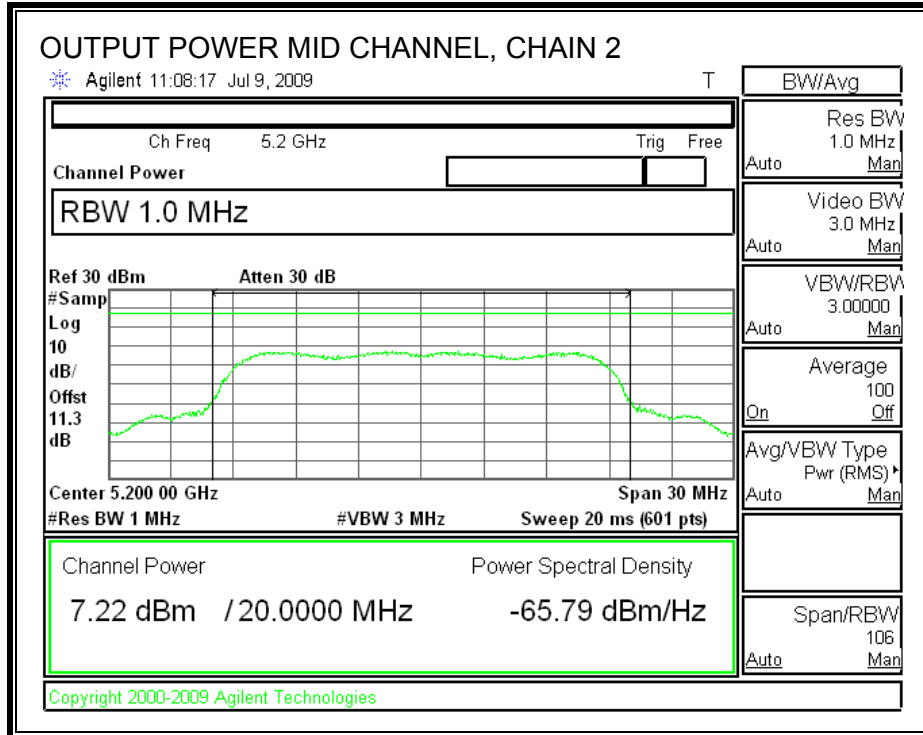

OUTPUT POWER, HIGH CHANNEL

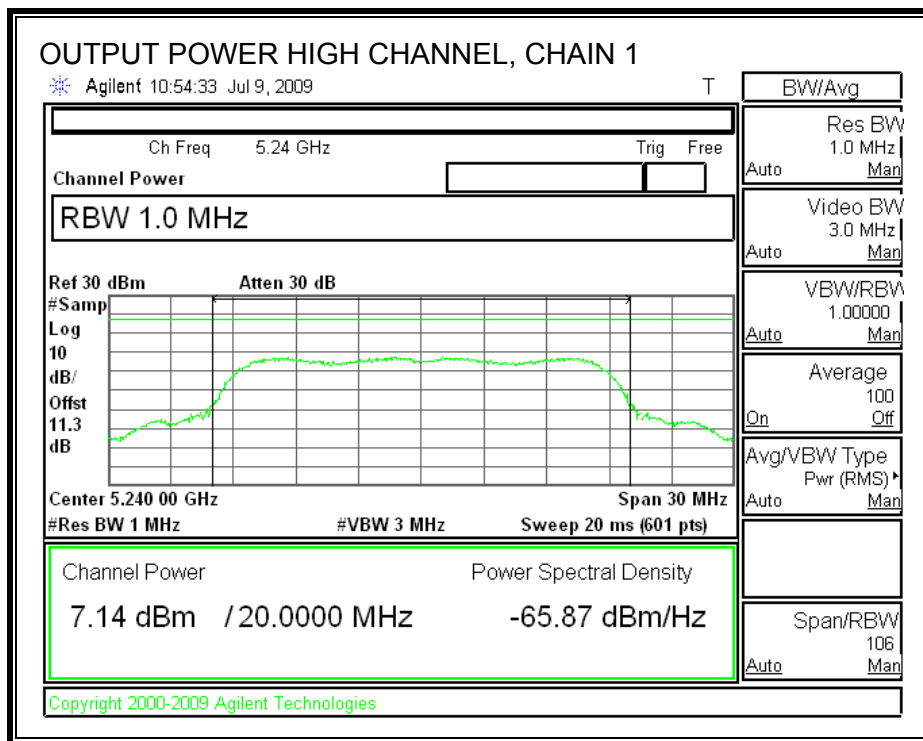
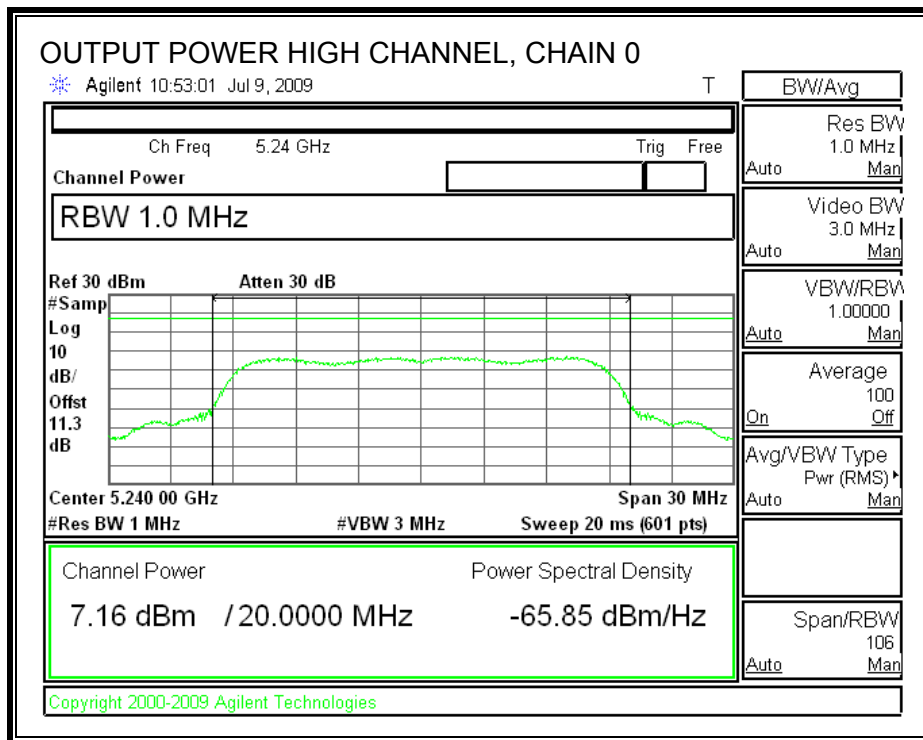

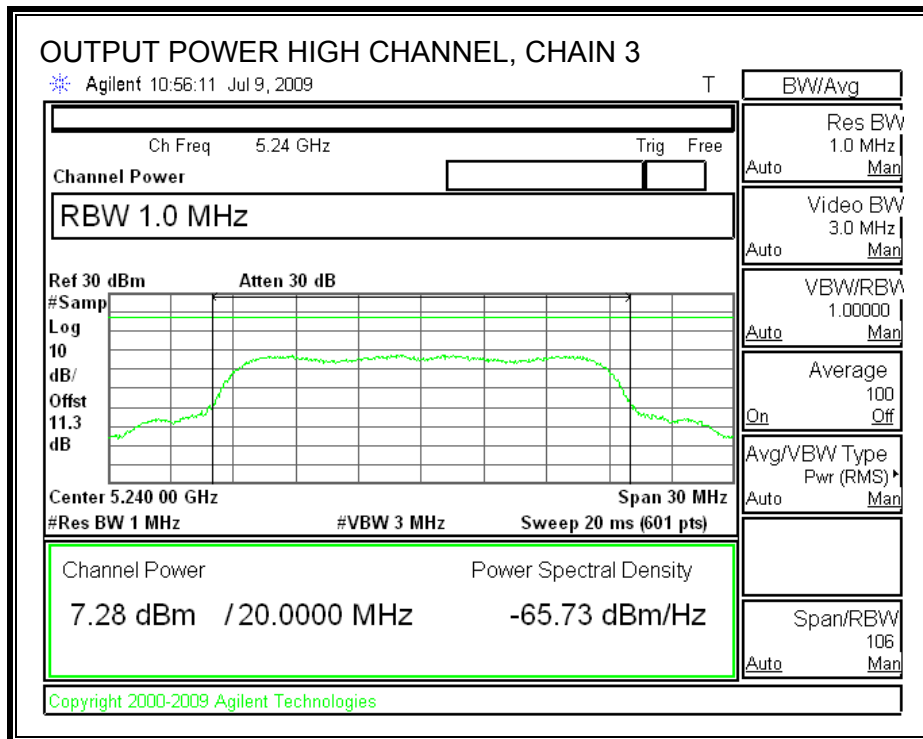
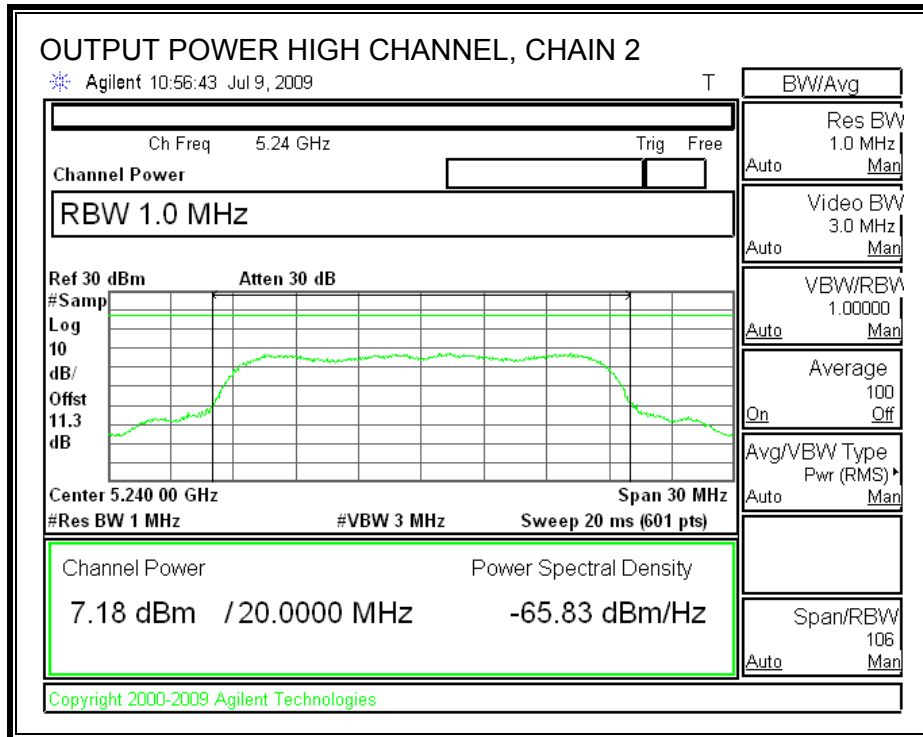

7.2.3. AVERAGE POWER

LIMITS

None; for reporting purposes only.

TEST PROCEDURE

The transmitter output is connected to a power meter.

The cable assembly insertion loss of 11.3 dB (including 10 dB pad and 1.3 dB cable) was entered as an offset in the power meter to allow for direct reading of power.

RESULTS

Frequency (MHz)	Chain 0 Power (dBm)	Chain 1 Power (dBm)	Chain 2 Power (dBm)	Chain 3 Power (dBm)
5180	7.14	7.26	7.10	7.23
5200	7.15	7.21	7.24	7.23
5240	7.35	7.32	7.39	7.28

7.2.4. PEAK POWER SPECTRAL DENSITY

LIMITS

FCC §15.407 (a) (2)

IC RSS-210 A9.2 (2)

For the 5.15-5.25 GHz band, the peak power spectral density shall not exceed 4 dBm in any 1 MHz band. If transmitting antennas of directional gain greater than 6 dBi are used, both the peak transmit power and the peak power spectral density shall be reduced by the amount in dB that the directional gain of the antenna exceeds 6 dBi.

The maximum antenna gain is less than 6 dBi; therefore the limit is 4 dBm.

TEST PROCEDURE

The test is performed in accordance with FCC Public Notice: APPENDIX A Guidelines for Assessing Unlicensed National Information Infrastructure (U-NII) Devices – Part 15, Subpart E, August 2002. PPSD method #2 was used.

Preliminary tests on individual chains, and on all chains with a combiner, were performed. The worst-case configuration was with a combiner, therefore final test were performed with all chains feeding a combiner.

RESULTS

Channel	Frequency (MHz)	PSD with Combiner (dBm)	Limit (dBm)	Margin (dB)
Low	5180	3.69	4	-0.31
Middle	5200	3.70	4	-0.30
High	5240	3.67	4	-0.33

POWER SPECTRAL DENSITY

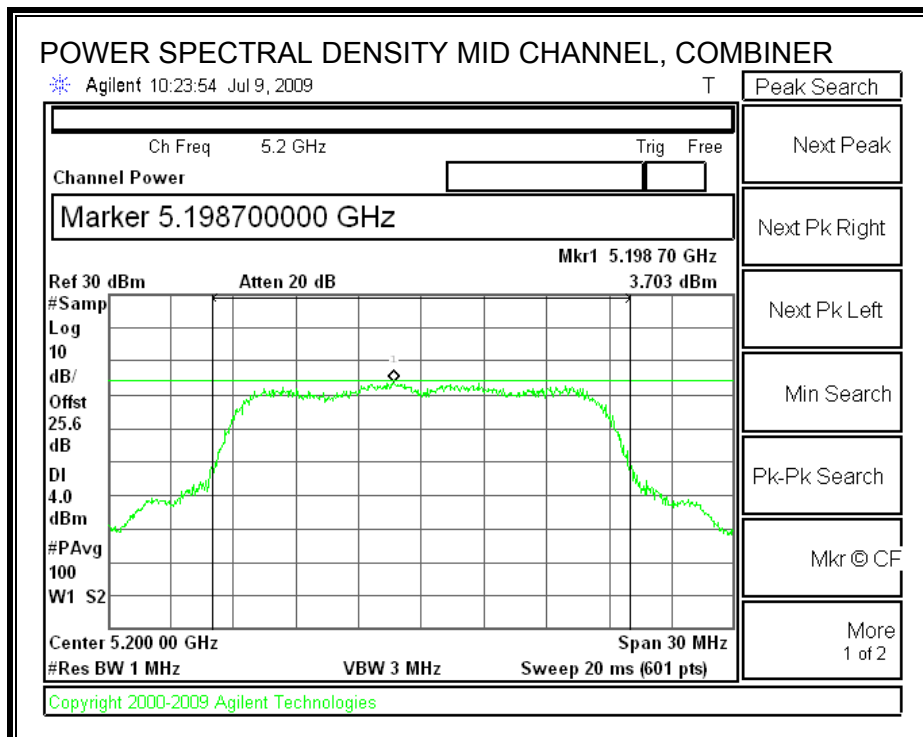
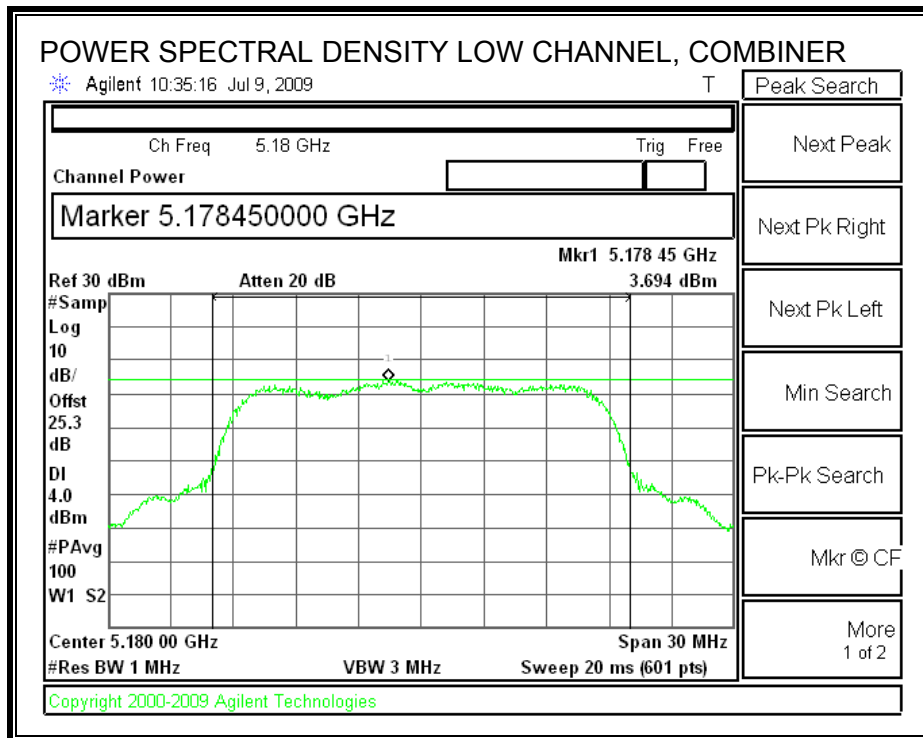

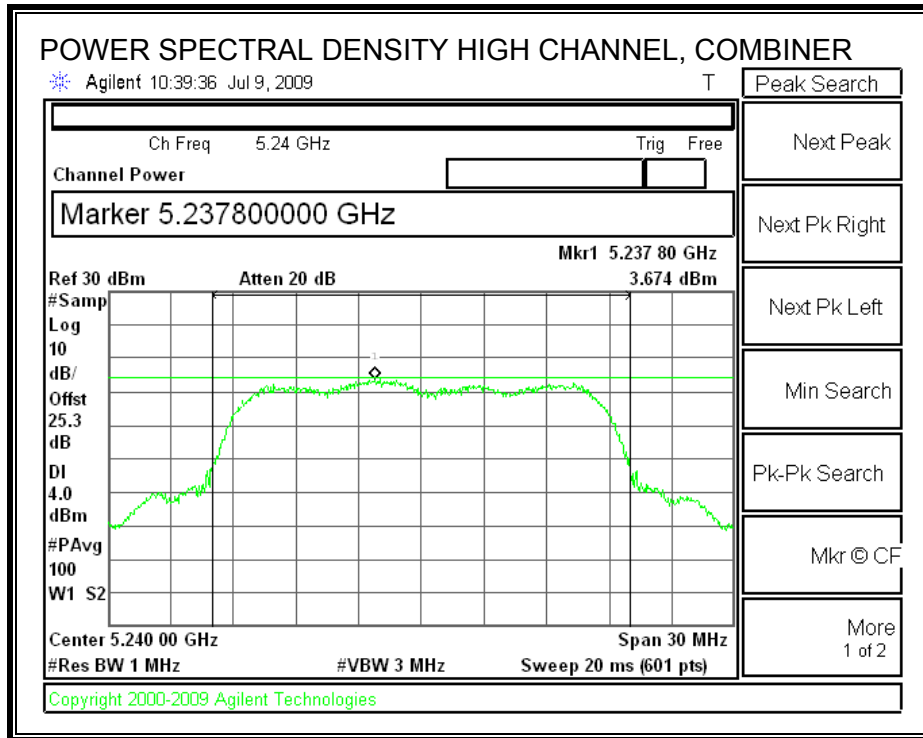

7.2.5. PEAK EXCURSION

LIMITS

FCC §15.407 (a) (6)

The ratio of the peak excursion of the modulation envelope (measured using a peak hold function) to the peak transmit power (measured as specified above) shall not exceed 13 dB across any 1 MHz bandwidth or the emission bandwidth whichever is less.

TEST PROCEDURE

The transmitter outputs are connected to the spectrum analyzer via a combiner.

The test is performed in accordance with FCC Public Notice: APPENDIX A Guidelines for Assessing Unlicensed National Information Infrastructure (U-NII) Devices – Part 15, Subpart E, August 2002.

Since Method # 1 was used for peak power measurements, Method # 1 settings are used for the second PPSD trace.

RESULTS

Channel	Frequency (MHz)	Peak Excursion (dB)	Limit (dB)	Margin (dB)
Low	5180	11.51	13	-1.49
Middle	5200	11.79	13	-1.21
High	5240	9.82	13	-3.18

PEAK EXCURSION

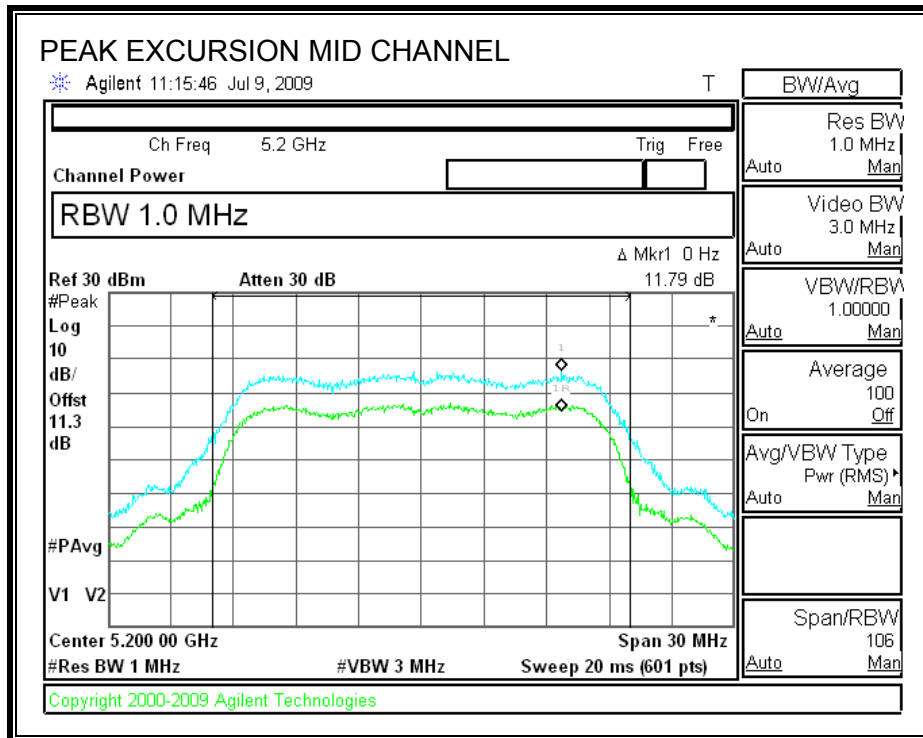
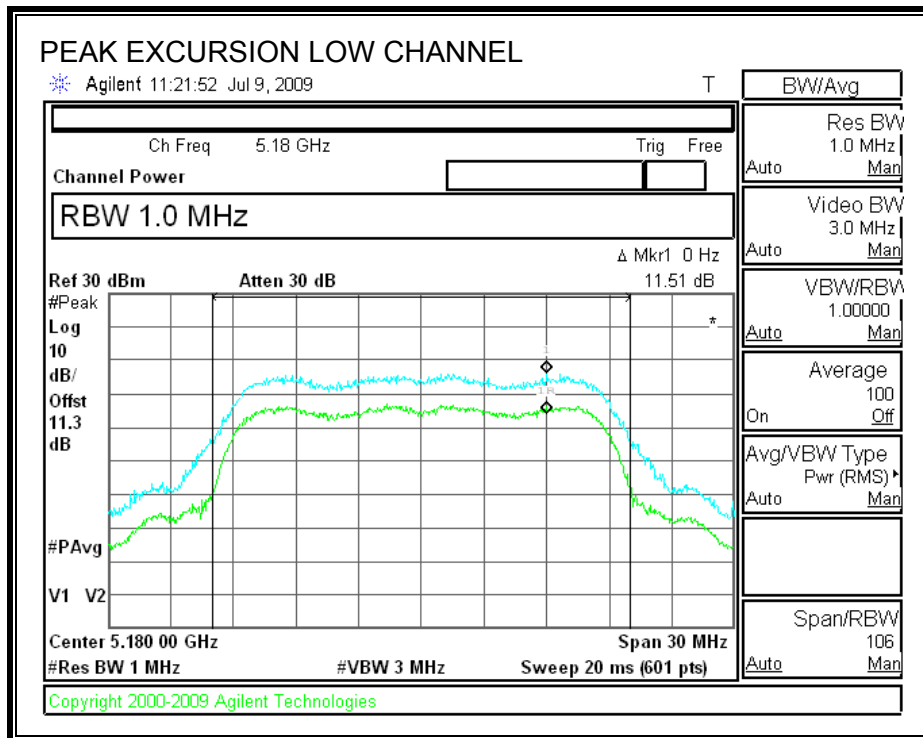

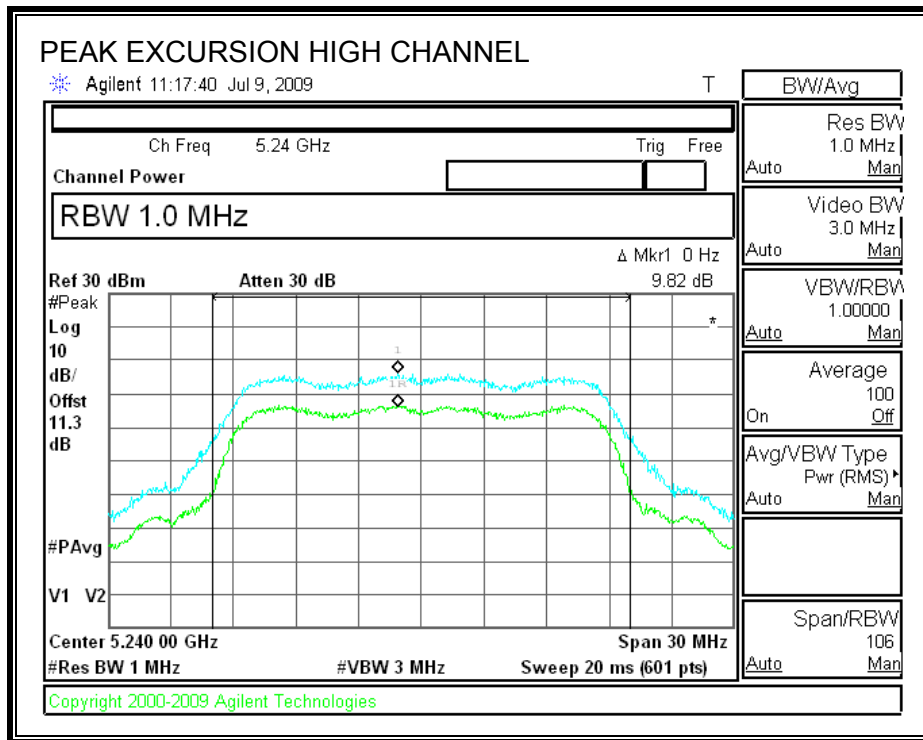

7.2.6. CONDUCTED SPURIOUS EMISSIONS

LIMITS

FCC §15.407 (b) (3)

IC RSS-210 A9.3 (3)

For transmitters operating in the 5.15-5.25 GHz band: all emissions outside of the 5.15-5.35 GHz band shall not exceed an EIRP of -27 dBm / MHz.

TEST PROCEDURE

Conducted RF measurements of the transmitter output are made to confirm that the EUT antenna port conducted emissions meet the specified limit and to identify any spurious signals that require further investigation or measurements on the radiated emissions site.

The transmitter output is connected to the spectrum analyzer. The resolution bandwidth is set to 1 MHz. The video bandwidth is set to 1 MHz. Peak detection measurements are compared to EIRP limit, adjusted for the maximum antenna gain.

Measurements are made over the 30 MHz to 40 GHz range with the transmitter set to the lowest, middle, and highest channels.

Preliminary tests on individual chains, and on all chains with a combiner, were performed. The worst-case configuration was with a combiner, therefore final test were performed with all chains feeding a combiner.

LOW CHANNEL SPURIOUS EMISSIONS

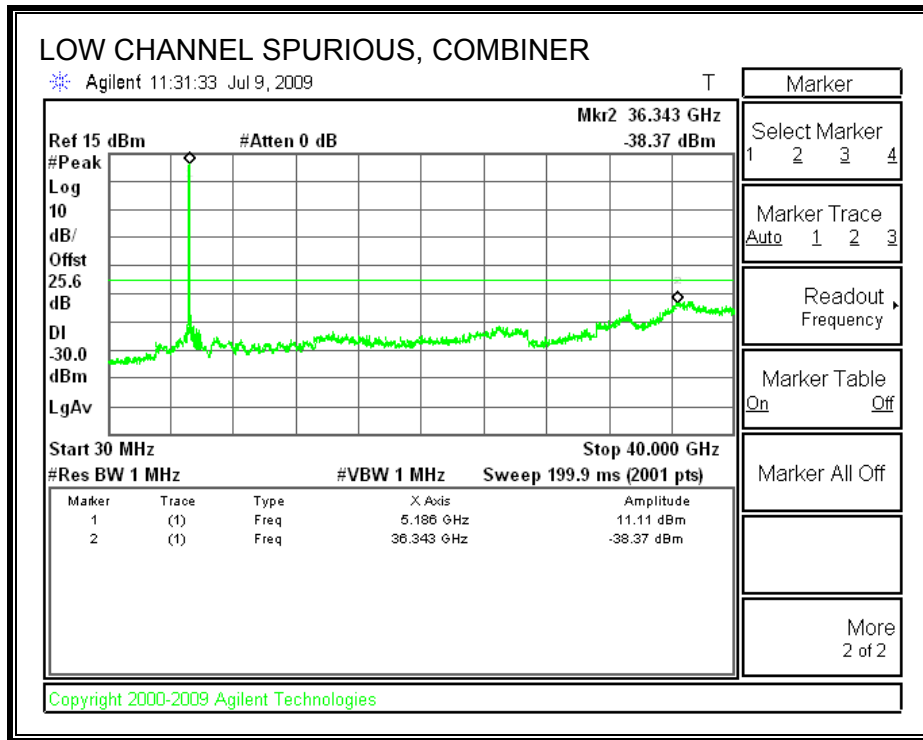

MID CHANNEL SPURIOUS EMISSIONS

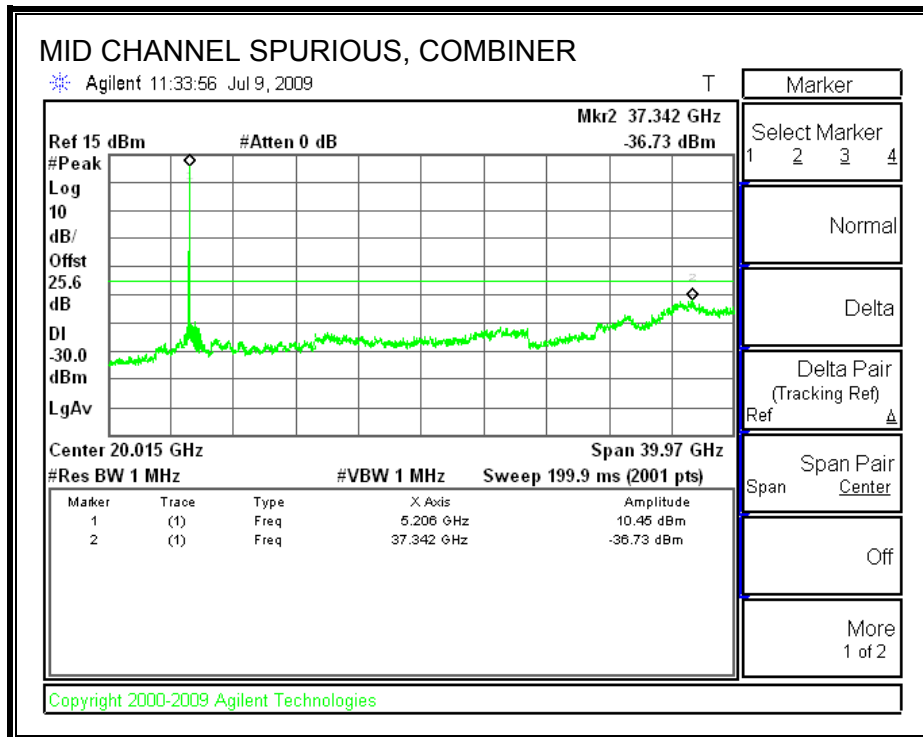

HIGH CHANNEL SPURIOUS EMISSIONS

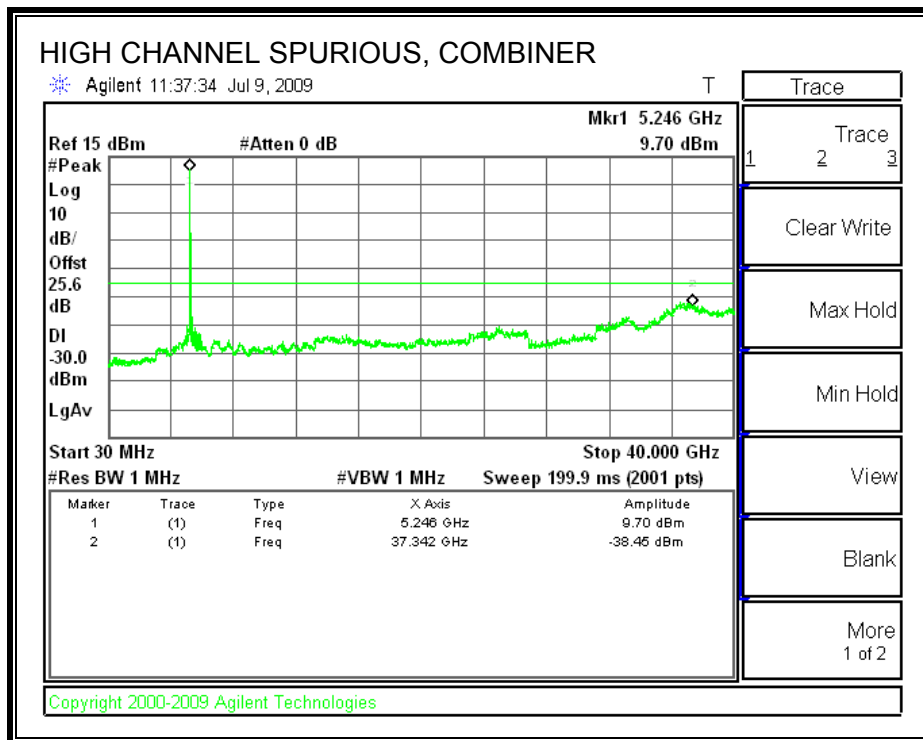

7.3. 5.2 GHz BAND CHANNEL TESTS FOR 802.11n HT40 MODE

7.3.1. 99% & 26 dB BANDWIDTH

LIMITS

None; for reporting purposes only.

TEST PROCEDURE

The transmitter output is connected to the spectrum analyzer. The RBW is set to 1% to 3% of the bandwidth. The VBW is set to 3 times the RBW. The sweep time is coupled. The spectrum analyzer internal bandwidth measurement function is utilized.

RESULTS

Channel	Frequency (MHz)	99% OBW (MHz)	26 dB BW (MHz)
Low	5190	35.5585	39.138
High	5230	36.0503	38.381

99% & 26 dB BANDWIDTH

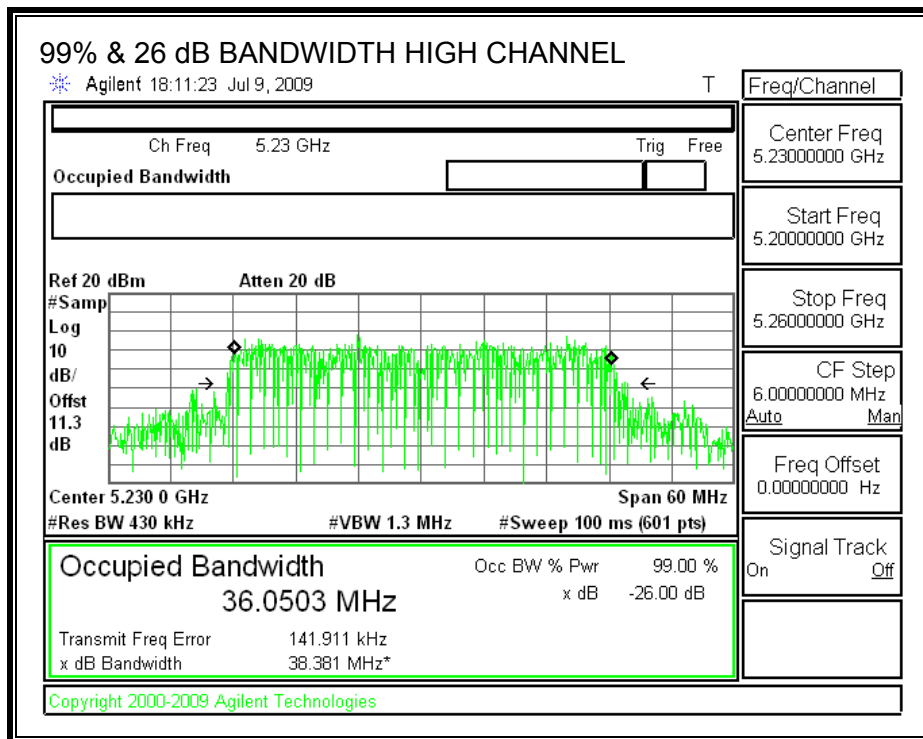
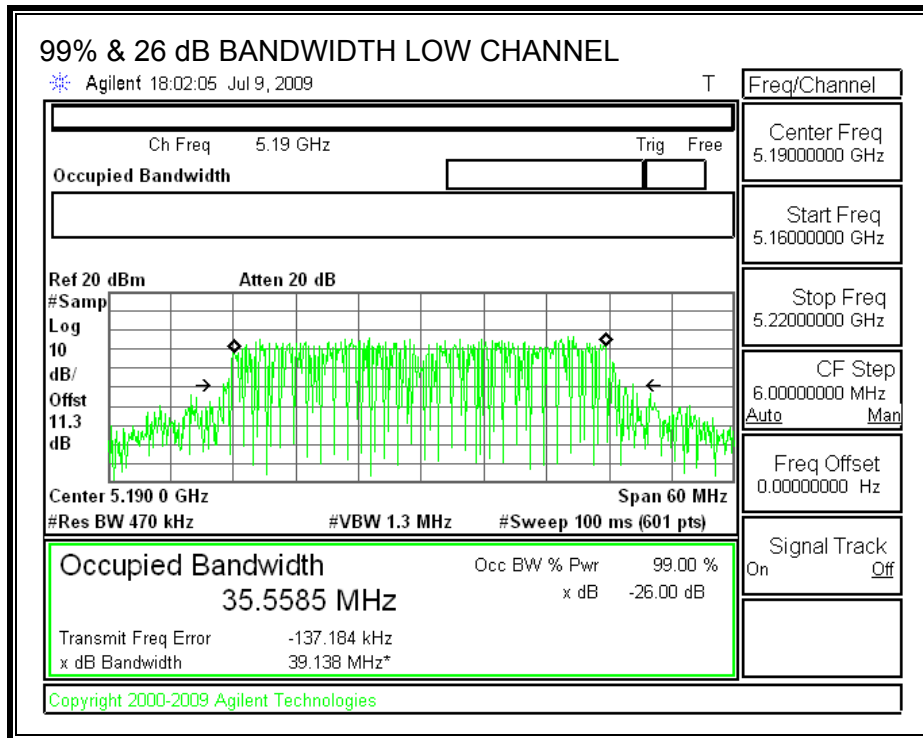

7.3.2. OUTPUT POWER

LIMITS

FCC §15.407 (a) (2)
 IC RSS-210 A9.2 (2)

For the 5.15-5.25 GHz band, the maximum conducted output power over the frequency band of operation shall not exceed the lesser of 50 mW or 4 dBm + 10 log B, where B is the 26-dB emission bandwidth in MHz. If transmitting antennas of directional gain greater than 6 dBi are used, both the peak transmit power and the peak power spectral density shall be reduced by the amount in dB that the directional gain of the antenna exceeds 6 dBi.

TEST PROCEDURE

The test is performed in accordance with FCC Public Notice: APPENDIX A Guidelines for Assessing Unlicensed National Information Infrastructure (U-NII) Devices – Part 15, Subpart E, August 2002.

The transmitter output operates continuously therefore Method # 1 is used.

RESULTS

Limit

Channel	Freq (MHz)	Fixed Limit (dBm)	B (MHz)	4 + 10 Log B Limit (dBm)	Antenna Gain (dBi)	Limit (dBm)
Low	5190	17	39.138	19.93	3	17.00
High	5230	17	38.381	19.84	3	17.00

Individual Chain Results

Channel	Freq (MHz)	Chain 0 Power (dBm)	Chain 1 Power (dBm)	Chain 2 Power (dBm)	Chain 3 Power (dBm)	Total Power (dBm)	Limit (dBm)	Margin (dB)
Low	5190	10.35	10.67	10.63	10.87	16.65	17.00	-0.35
High	5230	10.56	10.79	10.54	10.70	16.67	17.00	-0.33

OUTPUT POWER, LOW CHANNEL

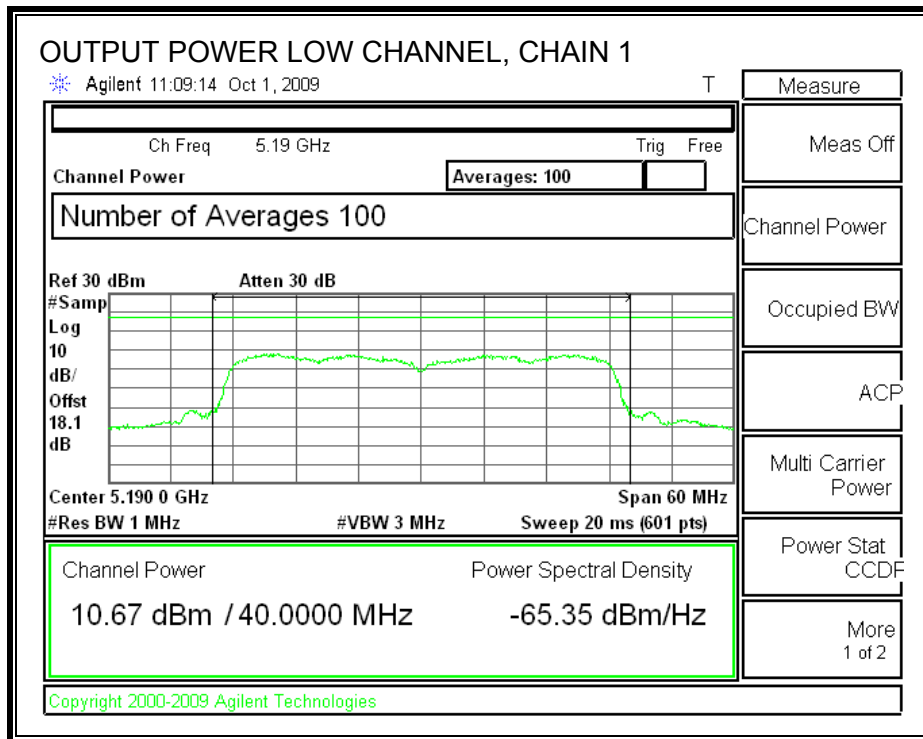
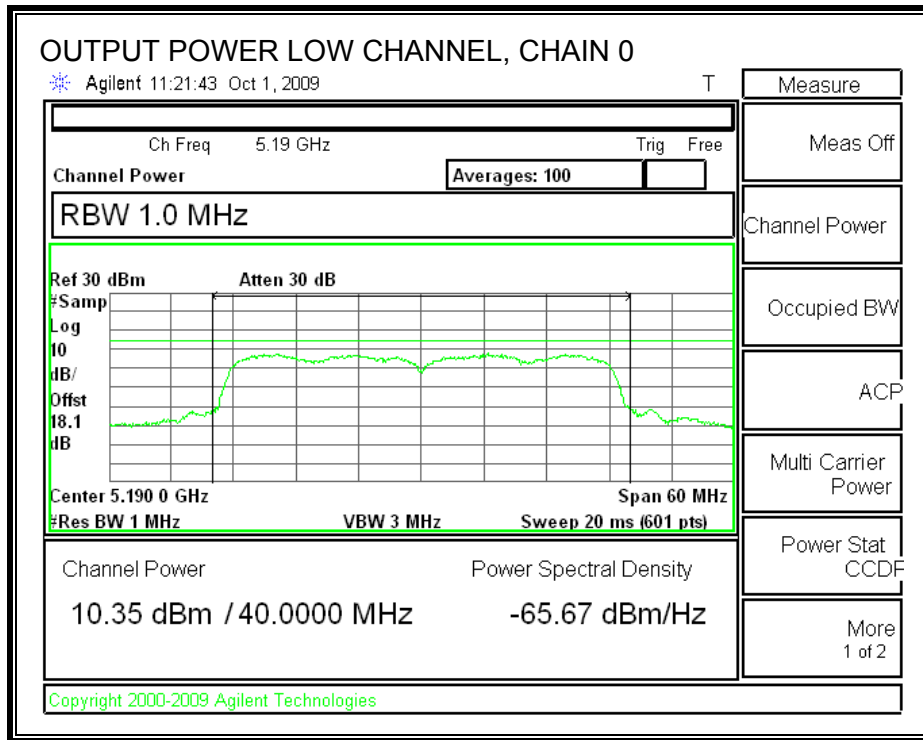

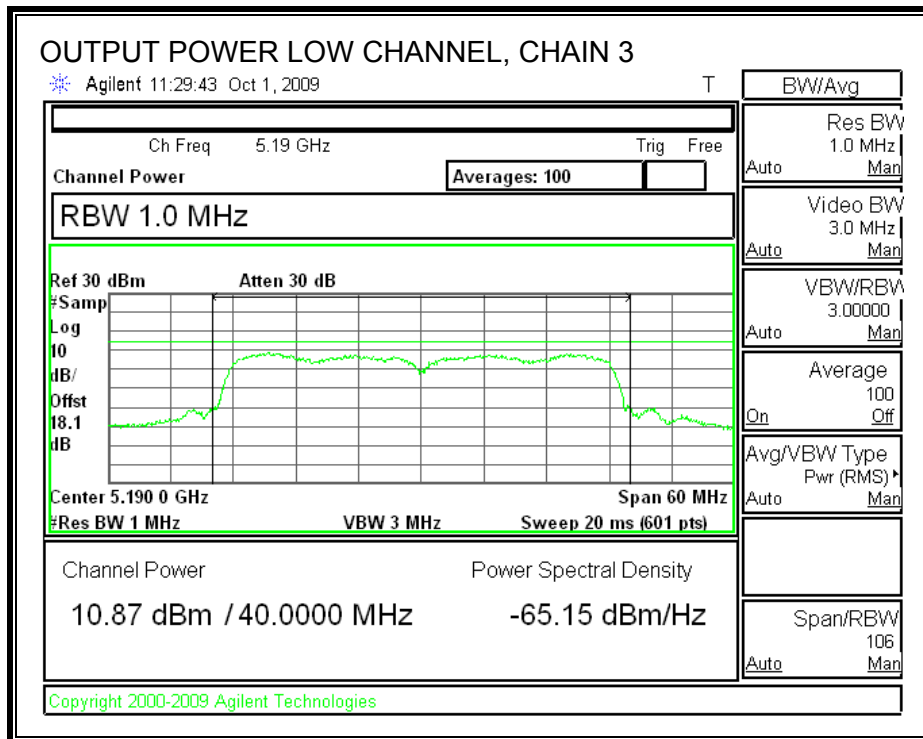
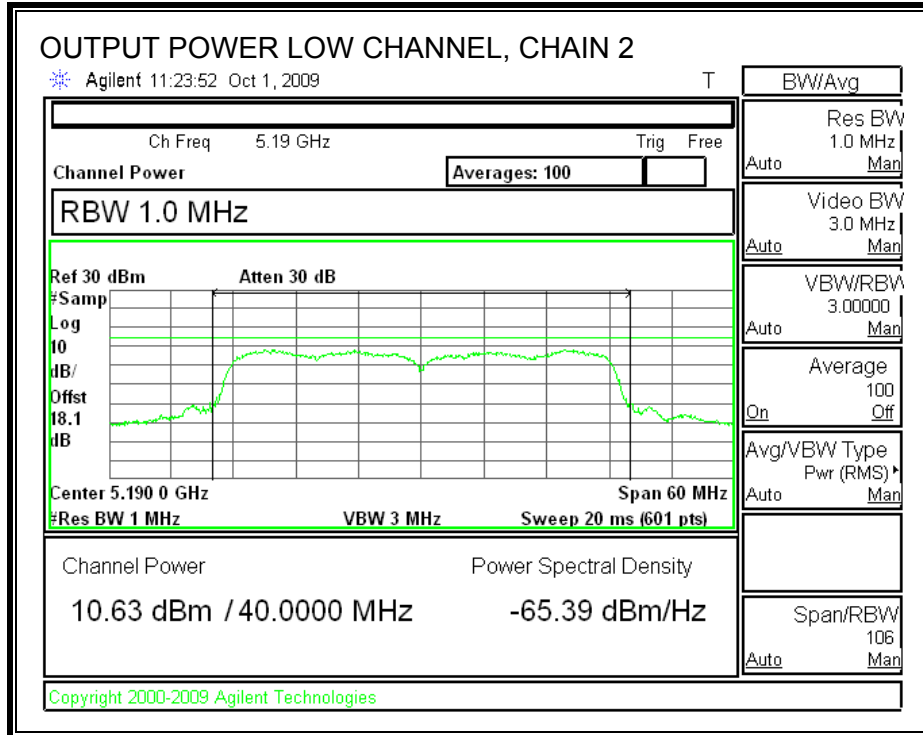

OUTPUT POWER, HIGH CHANNEL

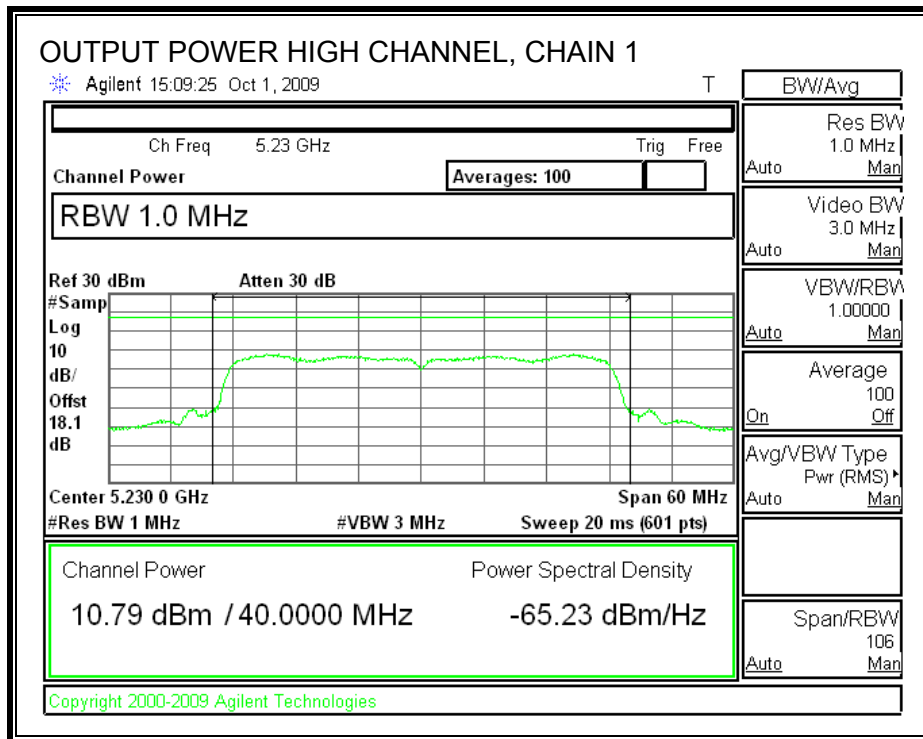
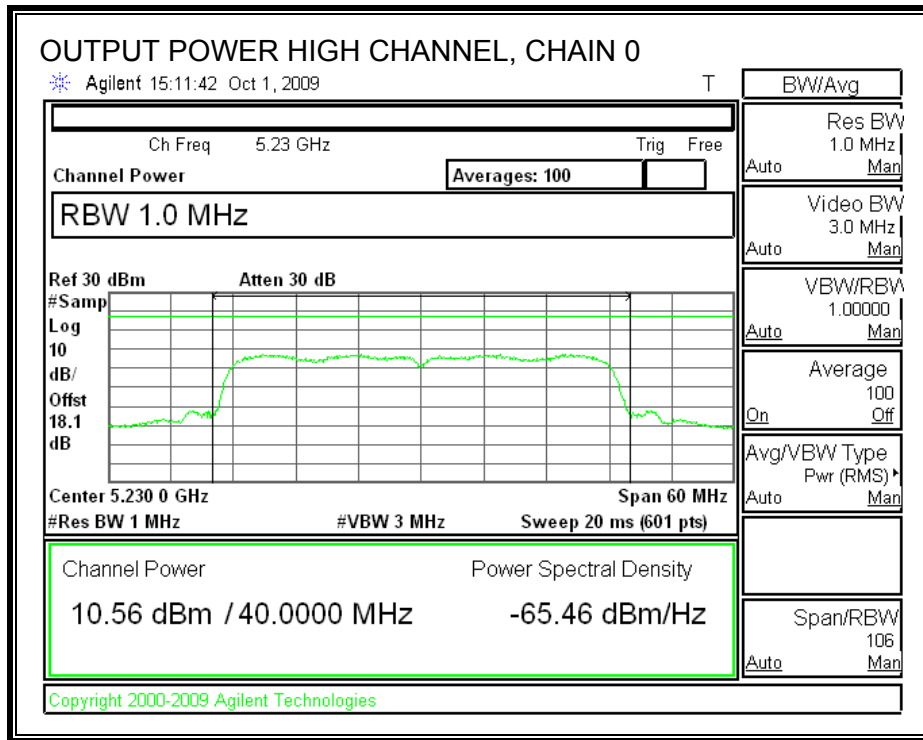

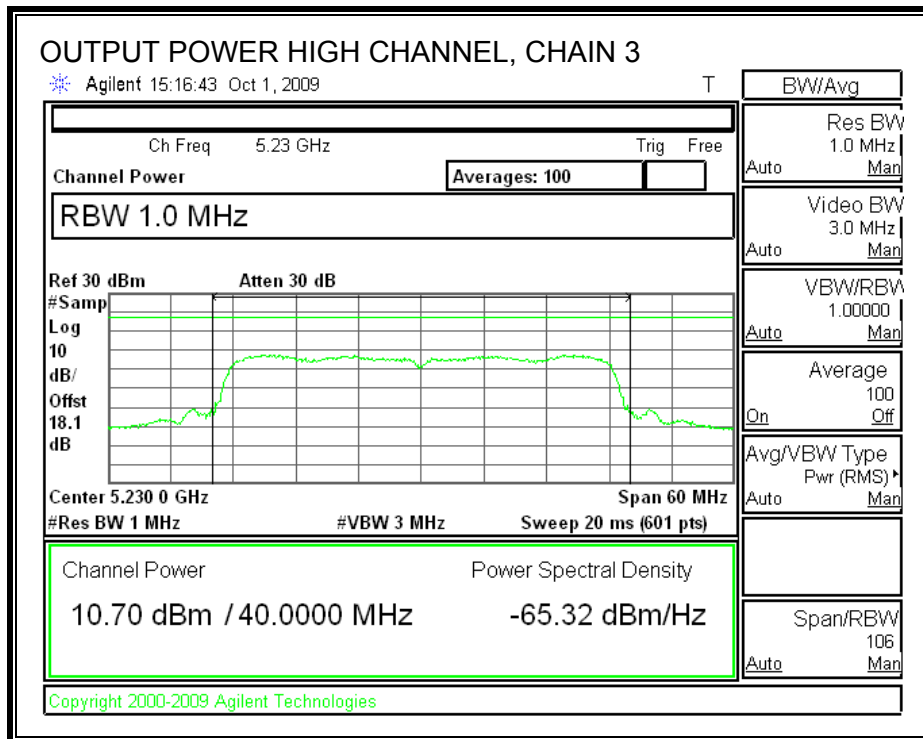
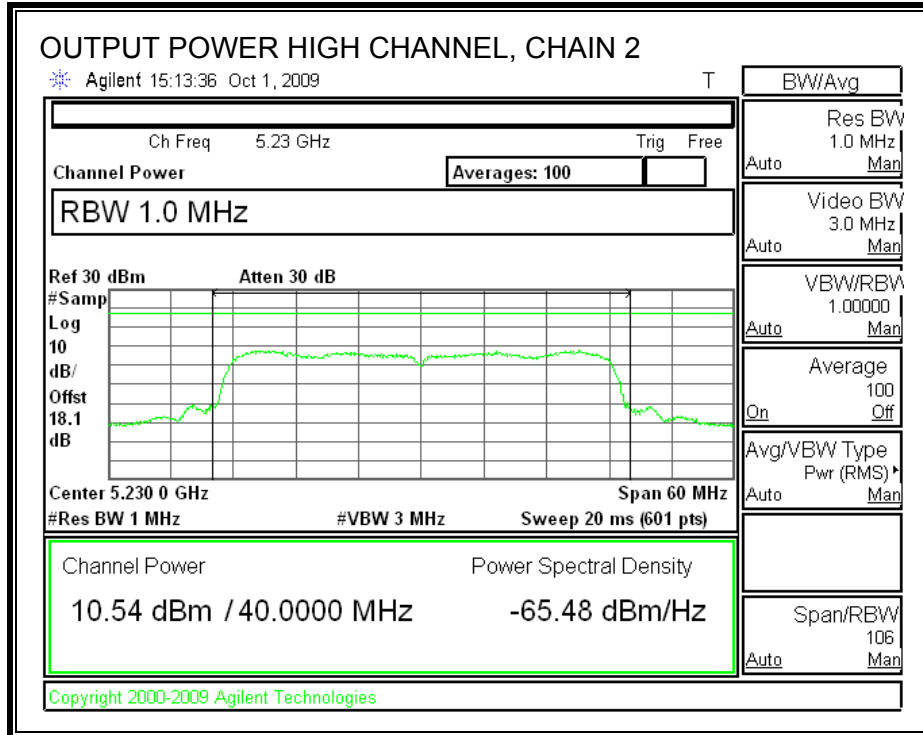

7.3.3. AVERAGE POWER

LIMITS

None; for reporting purposes only.

TEST PROCEDURE

The transmitter output is connected to a power meter.

The cable assembly insertion loss of 11.3 dB (including 10 dB pad and 1.3 dB cable) was entered as an offset in the power meter to allow for direct reading of power.

RESULTS

Frequency (MHz)	Chain 0 Power (dBm)	Chain 1 Power (dBm)	Chain 2 Power (dBm)	Chain 3 Power (dBm)
5190	10.57	10.98	10.59	10.82
5230	10.47	10.70	10.52	10.66

7.3.4. PEAK POWER SPECTRAL DENSITY

LIMITS

FCC §15.407 (a) (2)

IC RSS-210 A9.2 (2)

For the 5.15-5.25 GHz band, the peak power spectral density shall not exceed 4 dBm in any 1 MHz band. If transmitting antennas of directional gain greater than 6 dBi are used, both the peak transmit power and the peak power spectral density shall be reduced by the amount in dB that the directional gain of the antenna exceeds 6 dBi.

The maximum antenna gain is less than 6 dBi; therefore the limit is 4 dBm.

TEST PROCEDURE

The test is performed in accordance with FCC Public Notice: APPENDIX A Guidelines for Assessing Unlicensed National Information Infrastructure (U-NII) Devices – Part 15, Subpart E, August 2002. PPSD method #2 was used.

Preliminary tests on individual chains, and on all chains with a combiner, were performed. The worst-case configuration was with a combiner, therefore final test were performed with all chains feeding a combiner.

RESULTS

Channel	Frequency (MHz)	PSD with Combiner (dBm)	Limit (dBm)	Margin (dB)
Low	5190	2.559	4	-1.44
High	5230	3.892	4	-0.11

POWER SPECTRAL DENSITY

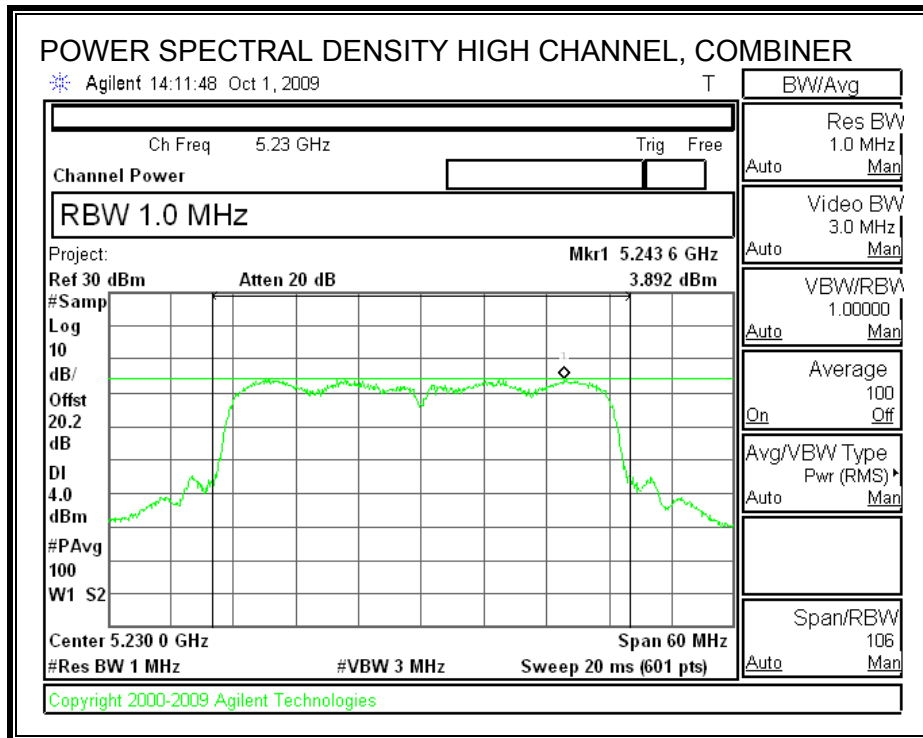
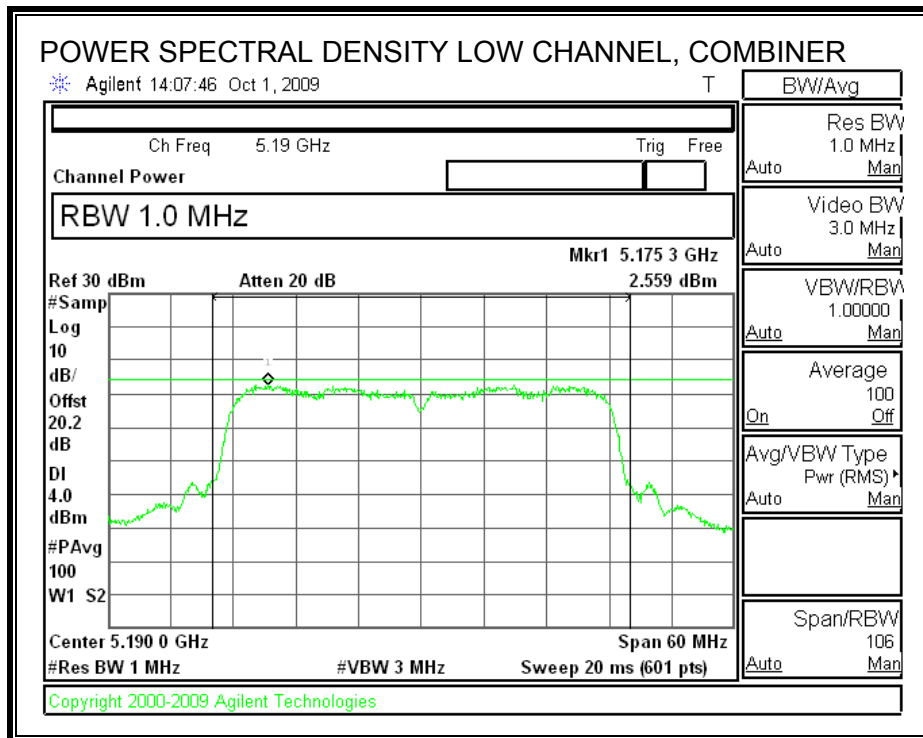

7.3.5. PEAK EXCURSION

LIMITS

FCC §15.407 (a) (6)

The ratio of the peak excursion of the modulation envelope (measured using a peak hold function) to the peak transmit power (measured as specified above) shall not exceed 13 dB across any 1 MHz bandwidth or the emission bandwidth whichever is less.

TEST PROCEDURE

The transmitter outputs are connected to the spectrum analyzer via a combiner.

The test is performed in accordance with FCC Public Notice: APPENDIX A Guidelines for Assessing Unlicensed National Information Infrastructure (U-NII) Devices – Part 15, Subpart E, August 2002.

Since Method # 1 was used for peak power measurements, Method # 1 settings are used for the second PPSD trace.

RESULTS

Channel	Frequency (MHz)	Peak Excursion (dB)	Limit (dB)	Margin (dB)
Low	5190	11.96	13	-1.04
High	5230	10.57	13	-2.43

PEAK EXCURSION

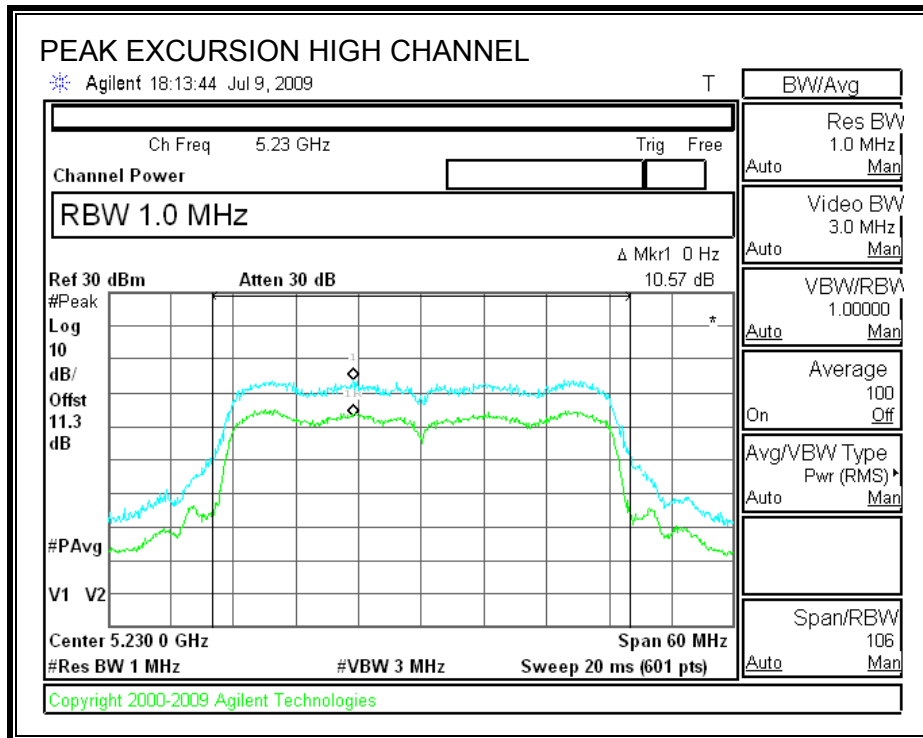
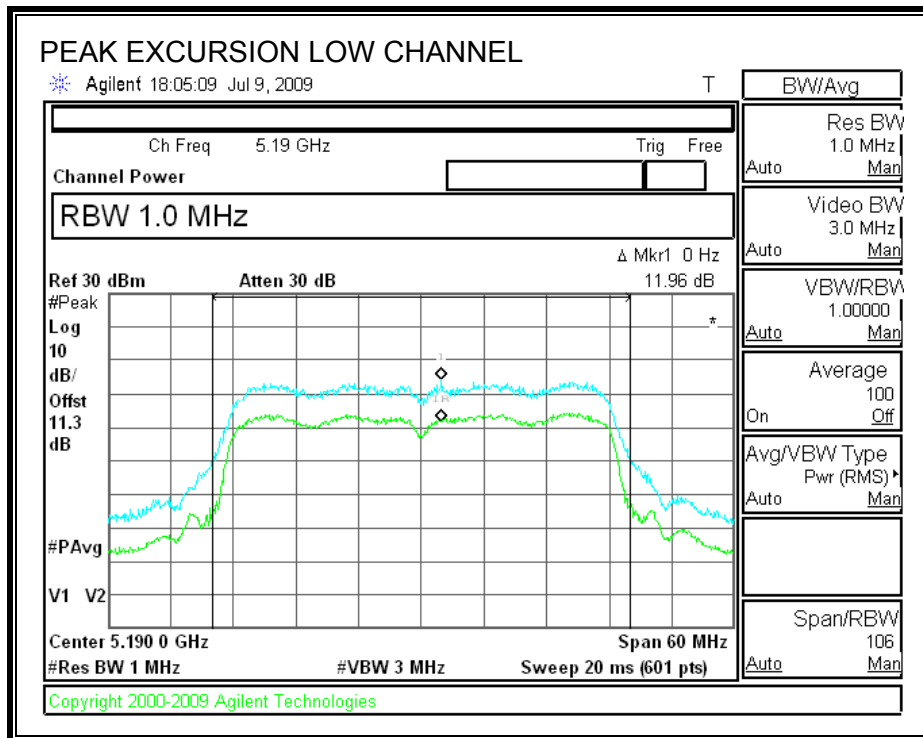

7.3.6. CONDUCTED SPURIOUS EMISSIONS

LIMITS

FCC §15.407 (b) (3)

IC RSS-210 A9.3 (3)

For transmitters operating in the 5.15-5.25 GHz band: all emissions outside of the 5.15-5.35 GHz band shall not exceed an EIRP of -27 dBm / MHz.

TEST PROCEDURE

Conducted RF measurements of the transmitter output are made to confirm that the EUT antenna port conducted emissions meet the specified limit and to identify any spurious signals that require further investigation or measurements on the radiated emissions site.

The transmitter output is connected to the spectrum analyzer. The resolution bandwidth is set to 1 MHz. The video bandwidth is set to 1 MHz. Peak detection measurements are compared to EIRP limit, adjusted for the maximum antenna gain.

Measurements are made over the 30 MHz to 40 GHz range with the transmitter set to the lowest, middle, and highest channels.

Preliminary tests on individual chains, and on all chains with a combiner, were performed. The worst-case configuration was with a combiner, therefore final test were performed with all chains feeding a combiner.

LOW CHANNEL SPURIOUS EMISSIONS

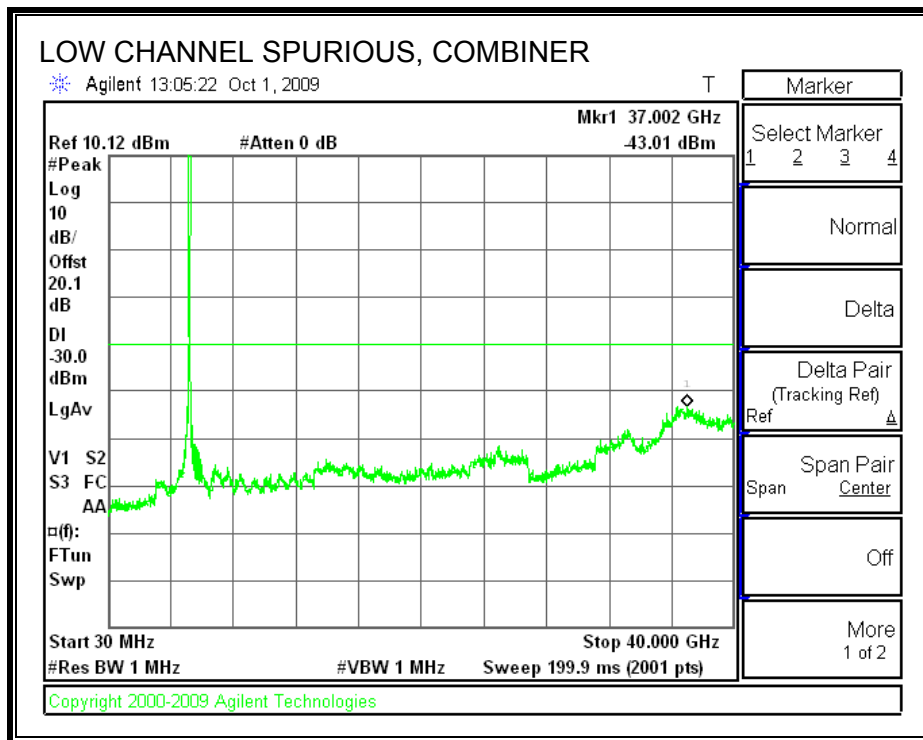

HIGH CHANNEL SPURIOUS EMISSIONS

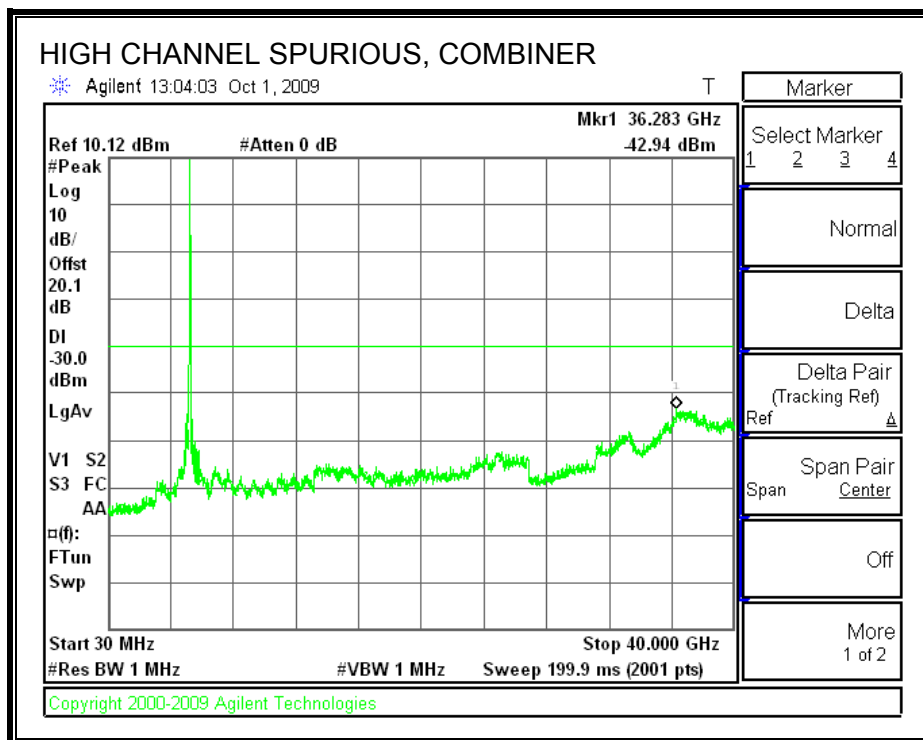

7.4. 5.3 GHz BAND CHANNEL TESTS FOR 802.11a MODE

7.4.1. 26 dB and 99% BANDWIDTH

LIMITS

None; for reporting purposes only.

TEST PROCEDURE

The transmitter outputs are connected to the spectrum analyzer via a combiner. The RBW is set to 1% to 3% of the measured bandwidth. The VBW is set to 3 times the RBW. The sweep time is coupled. The spectrum analyzer internal bandwidth function is utilized.

RESULTS

Channel	Frequency (MHz)	26 dB Bandwidth (MHz)	99% Bandwidth (MHz)
Low	5260	18.4630	16.4130
Middle	5300	18.8510	16.4084
High	5320	18.5600	16.4537

26 dB and 99% BANDWIDTH

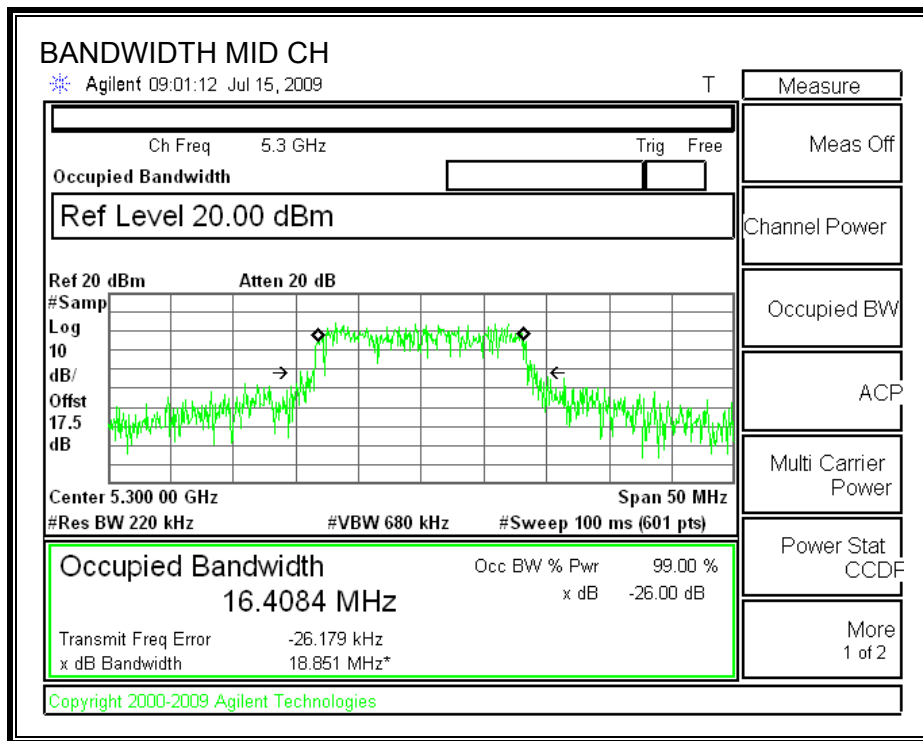
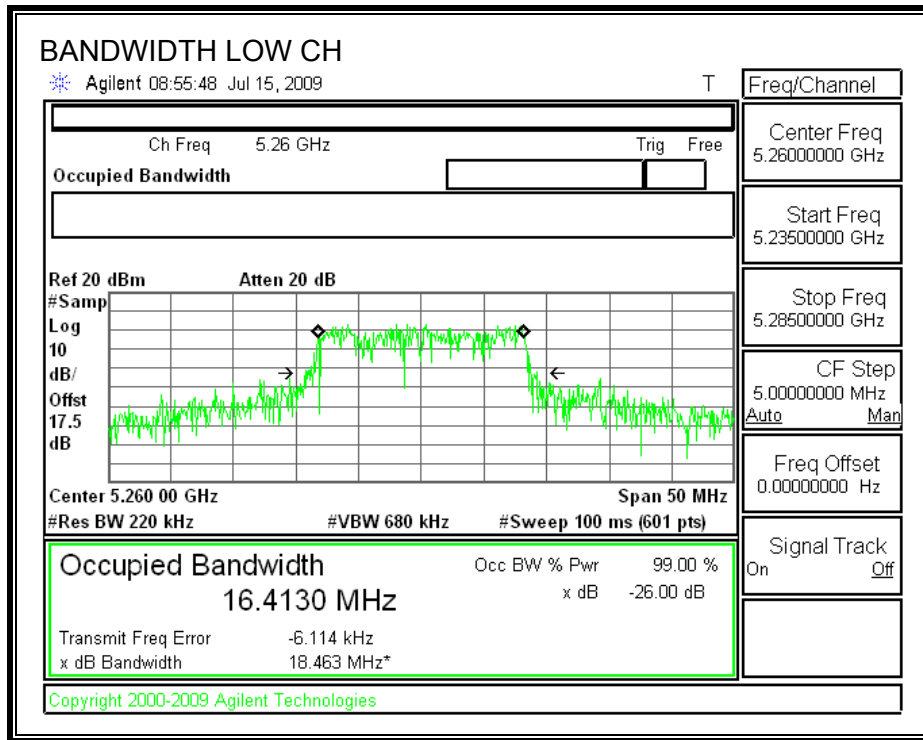

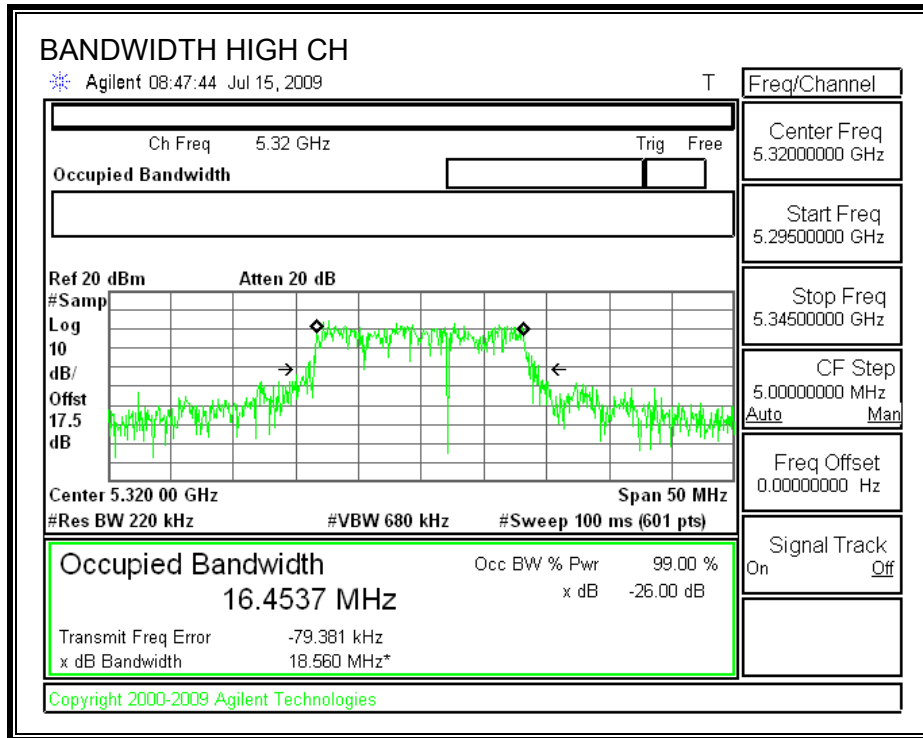

7.4.2. OUTPUT POWER

LIMITS

FCC §15.407 (a) (1)
 IC RSS-210 A9.2 (1)

Antenna gain of Chain 1 = antenna gain of Chain 2.

Antenna Gain (dBi)	10 Log (# Tx Chains) (dB)	Effective Legacy Gain (dBi)
3	3.01	6.01

For the 5.25-5.35 GHz band, the maximum conducted output power over the frequency band of operation shall not exceed the lesser of 250 mW or 11 dBm + 10 log B, where B is the 26-dB emission bandwidth in MHz. If transmitting antennas of directional gain greater than 6 dBi are used, both the peak transmit power and the peak power spectral density shall be reduced by the amount in dB that the directional gain of the antenna exceeds 6 dBi.

TEST PROCEDURE

The test is performed in accordance with FCC Public Notice: APPENDIX A Guidelines for Assessing Unlicensed National Information Infrastructure (U-NII) Devices – Part 15, Subpart E, August 2002.

The transmitter output operates continuously therefore Method # 1 is used.

RESULTS

Limit

Channel	Frequency (MHz)	Fixed Limit (dBm)	B (MHz)	11 + 10 Log B Limit (dBm)	Effective Ant Gain (dBi)	Limit (dBm)
Low	5260	24	18.4630	23.66	6.01	23.65
Mid	5300	24	18.8510	23.75	6.01	23.74
High	5320	24	18.5600	23.69	6.01	23.68

Individual Chain Results

Channel	Frequency (MHz)	Chain 0 Power (dBm)	Chain 1 Power (dBm)	Total Power (dBm)	Limit (dBm)	Margin (dB)
Low	5260	16.03	16.06	19.06	23.65	-4.60
Mid	5300	16.02	16.25	19.15	23.74	-4.60
High	5320	16.08	16.09	19.10	23.68	-4.58

OUTPUT POWER, LOW CHANNEL

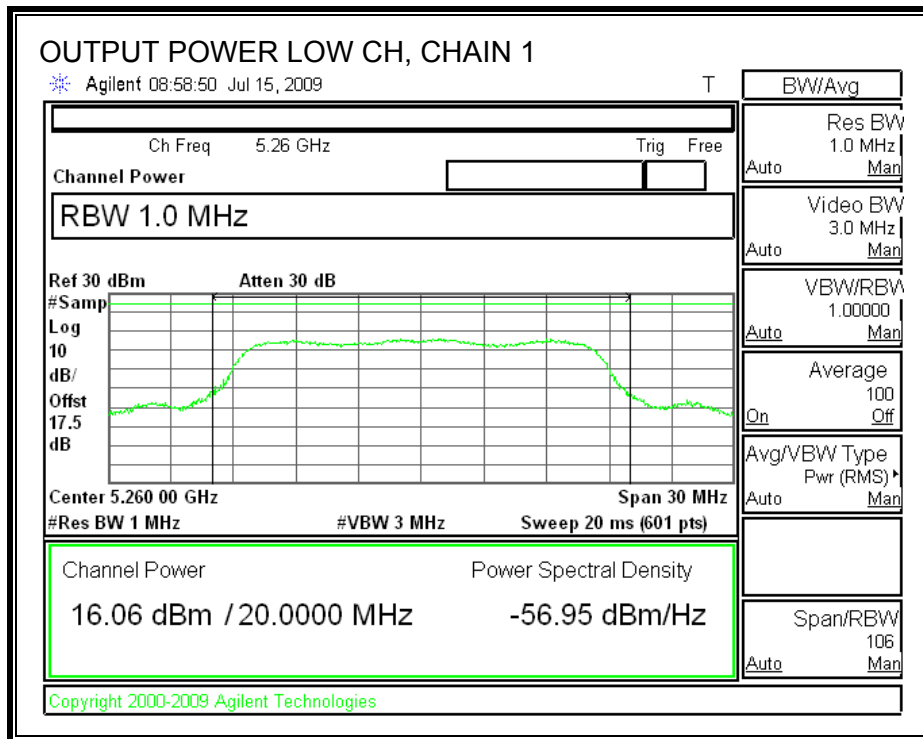
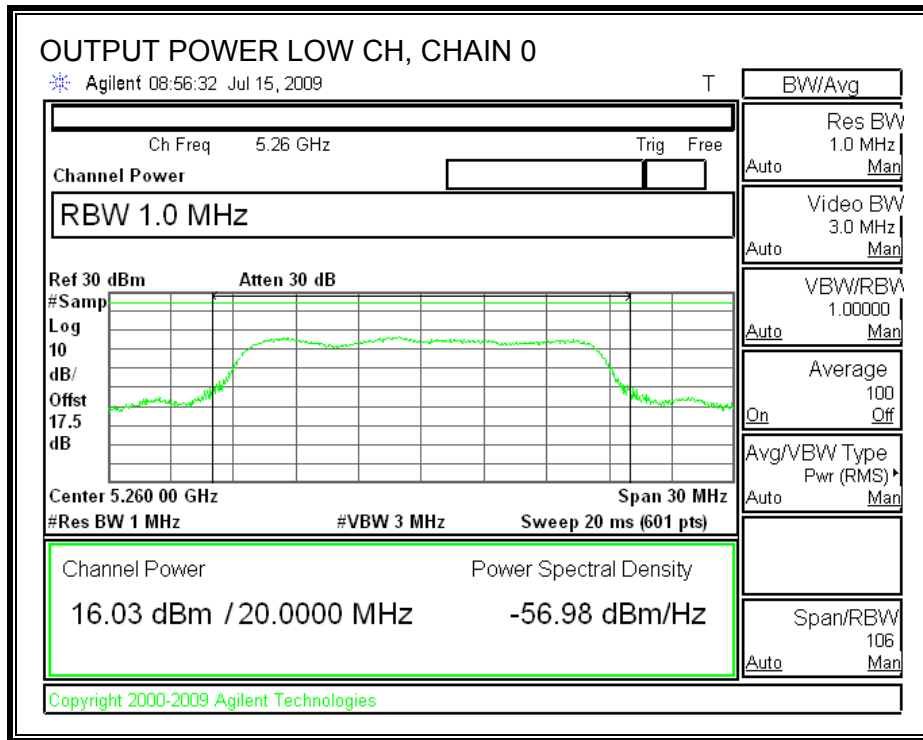

OUTPUT POWER, MID CHANNEL

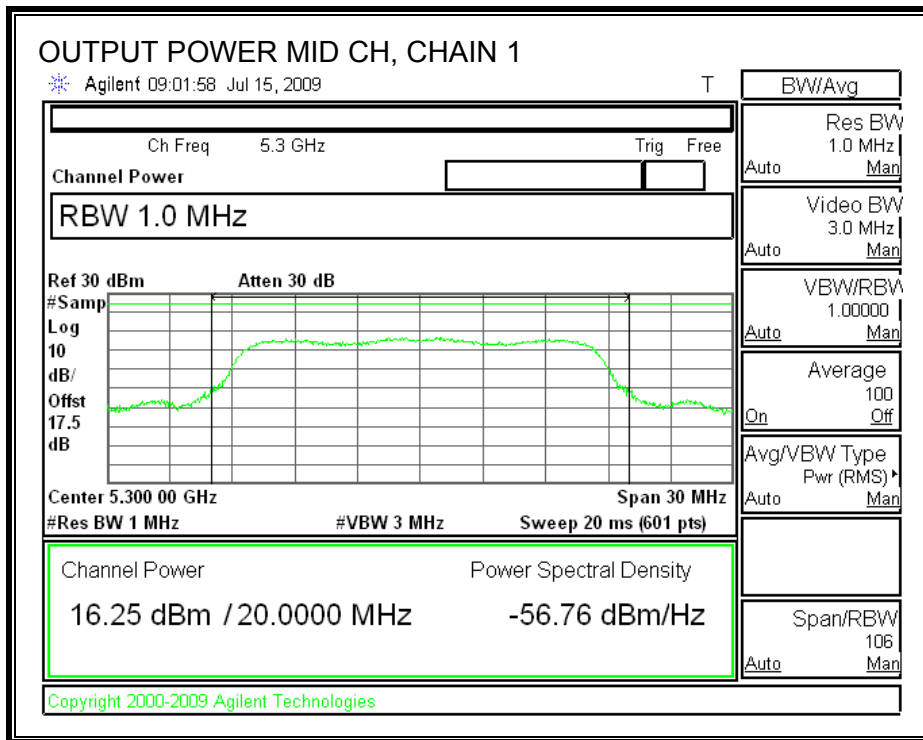
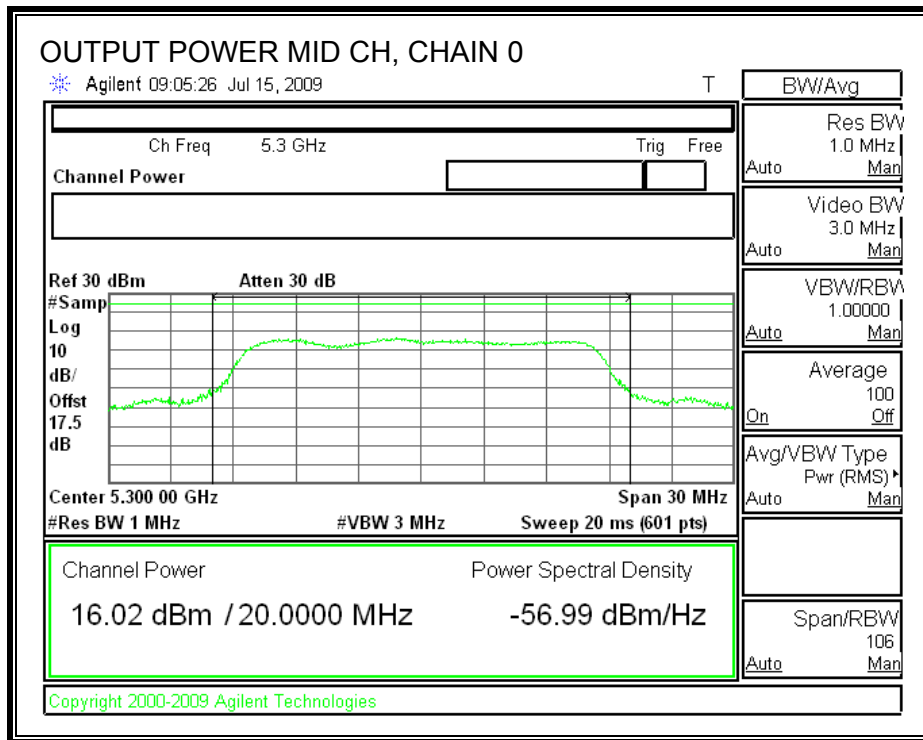

OUTPUT POWER, HIGH CHANNEL

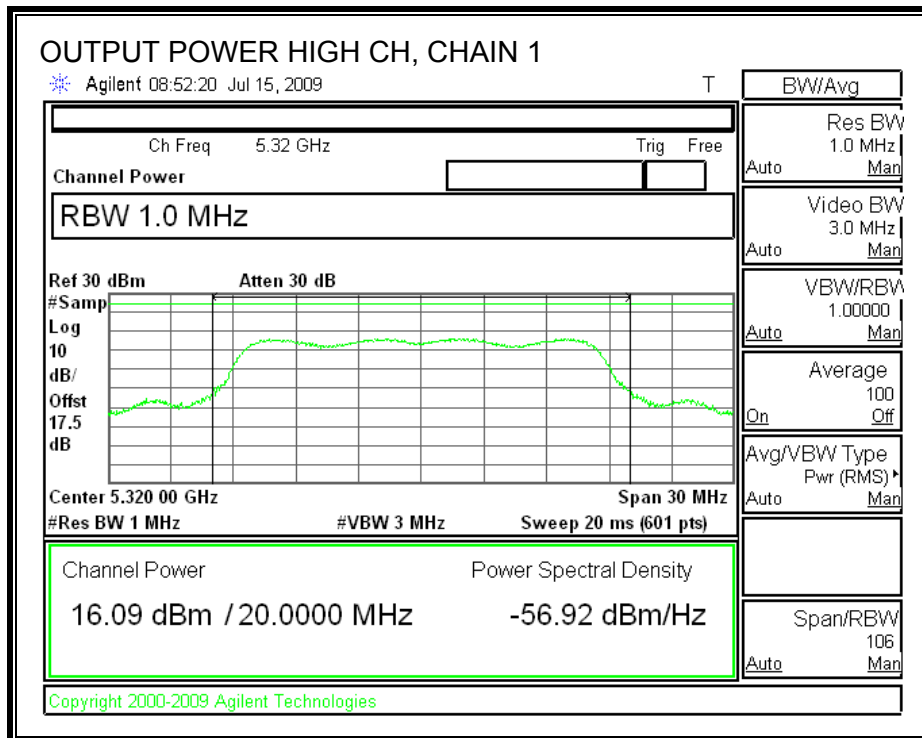
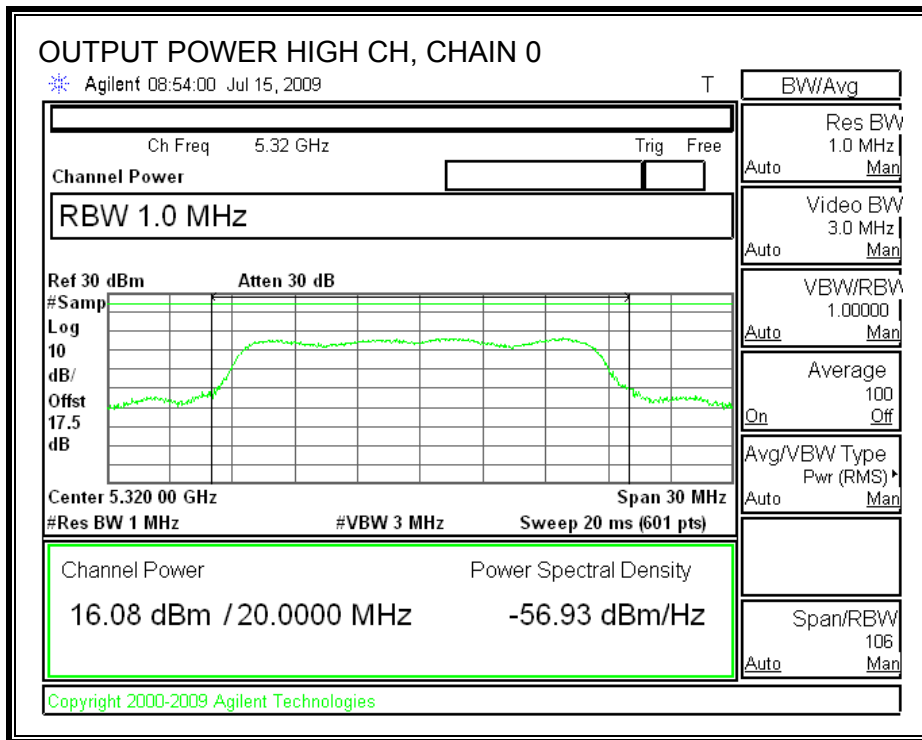

7.4.3. AVERAGE POWER

LIMITS

None; for reporting purposes only.

TEST PROCEDURE

The transmitter output is connected to a power meter.

RESULTS

The cable assembly insertion loss of 11.3 dB (including 10 dB pad and 1.3 dB cable) was entered as an offset in the power meter to allow for direct reading of power.

Channel	Frequency (MHz)	Chain 0 Power (dBm)	Chain 1 Power (dBm)	Total Power (dBm)
Low	5260	15.94	16.16	19.06
Middle	5300	16.14	16.32	19.24
High	5320	16.05	16.25	19.16

7.4.4. PEAK POWER SPECTRAL DENSITY

LIMITS

FCC §15.407 (a) (1)

IC RSS-210 A9.2 (1)

Use this table if antenna gain for Chain 1 = antenna gain for Chain 2

Antenna Gain (dBi)	10 Log (# Tx Chains) (dB)	Effective Legacy Gain (dBi)
3	3.01	6.01

For the 5.25–5.35 GHz band, the peak power spectral density shall not exceed 11 dBm in any 1 MHz band. If transmitting antennas of directional gain greater than 6 dBi are used, both the peak transmit power and the peak power spectral density shall be reduced by the amount in dB that the directional gain of the antenna exceeds 6 dBi.

The maximum effective antenna gain is 6.01 dBi, therefore the limit is 10.99 dBm.

TEST PROCEDURE

The test is performed in accordance with FCC Public Notice: APPENDIX A Guidelines for Assessing Unlicensed National Information Infrastructure (U-NII) Devices – Part 15, Subpart E, August 2002. PPSD method #2 was used.

RESULTS

Channel	Frequency (MHz)	PPSD With Combiner (dBm)	Limit (dBm)	Margin (dB)
Low	5260	10.87	10.99	-0.12
Middle	5300	10.77	10.99	-0.22
High	5320	10.52	10.99	-0.47

POWER SPECTRAL DENSITY WITH COMBINER

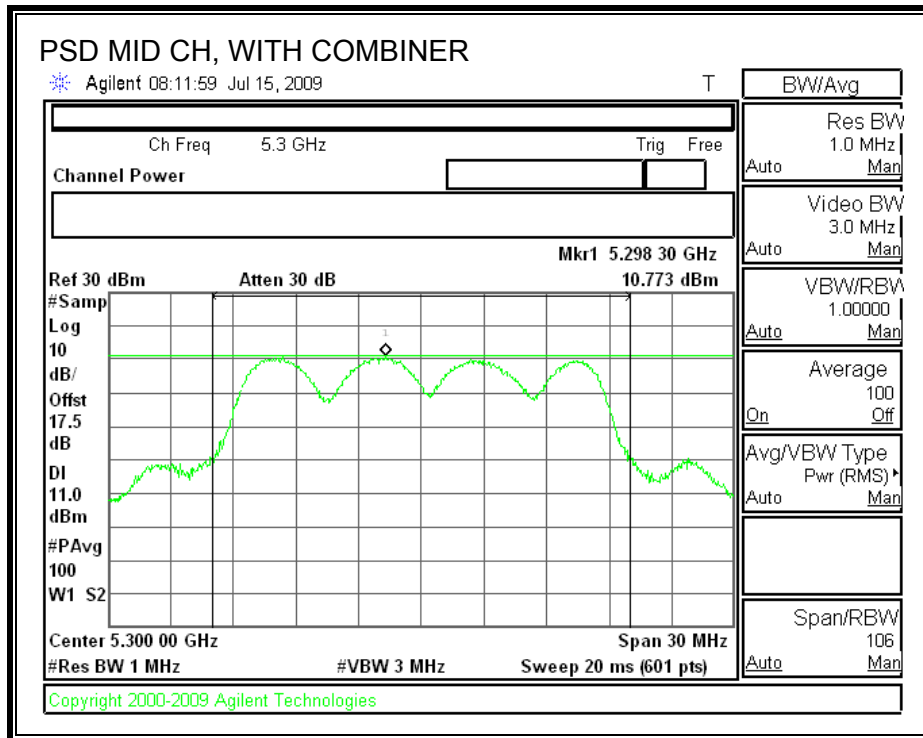
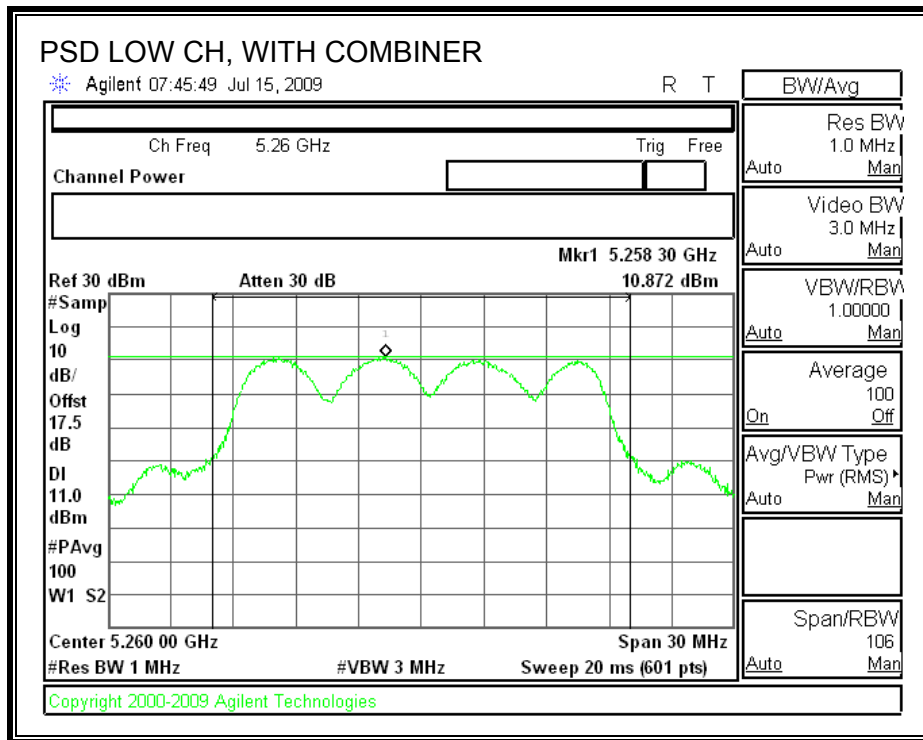

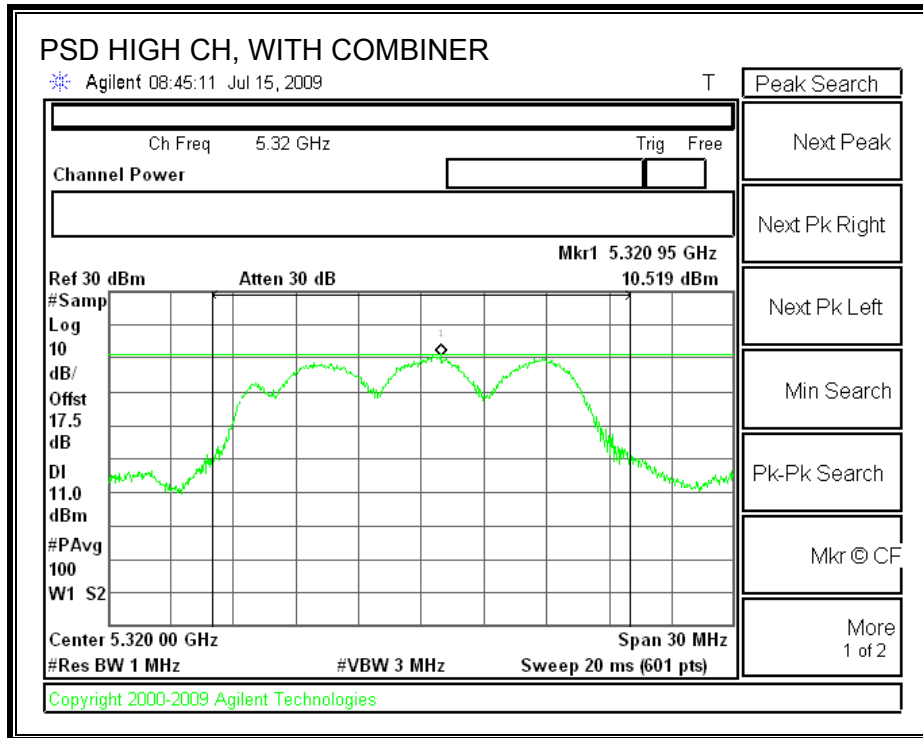

7.4.5. PEAK EXCURSION

LIMITS

FCC §15.407 (a) (6)

The ratio of the peak excursion of the modulation envelope (measured using a peak hold function) to the peak transmit power (measured as specified above) shall not exceed 13 dB across any 1 MHz bandwidth or the emission bandwidth whichever is less.

TEST PROCEDURE

The transmitter outputs are connected to the spectrum analyzer via a combiner.

The test is performed in accordance with FCC Public Notice: APPENDIX A Guidelines for Assessing Unlicensed National Information Infrastructure (U-NII) Devices – Part 15, Subpart E, August 2002.

Since Method # 1 was used for peak power measurements, Method # 1 settings are used for the second PPSD trace.

RESULTS

Channel	Frequency (MHz)	Peak Excursion (dB)	Limit (dB)	Margin (dB)
Low	5260	10.48	13	-2.52
Middle	5300	10.20	13	-2.80
High	5320	10.08	13	-2.92

PEAK EXCURSION

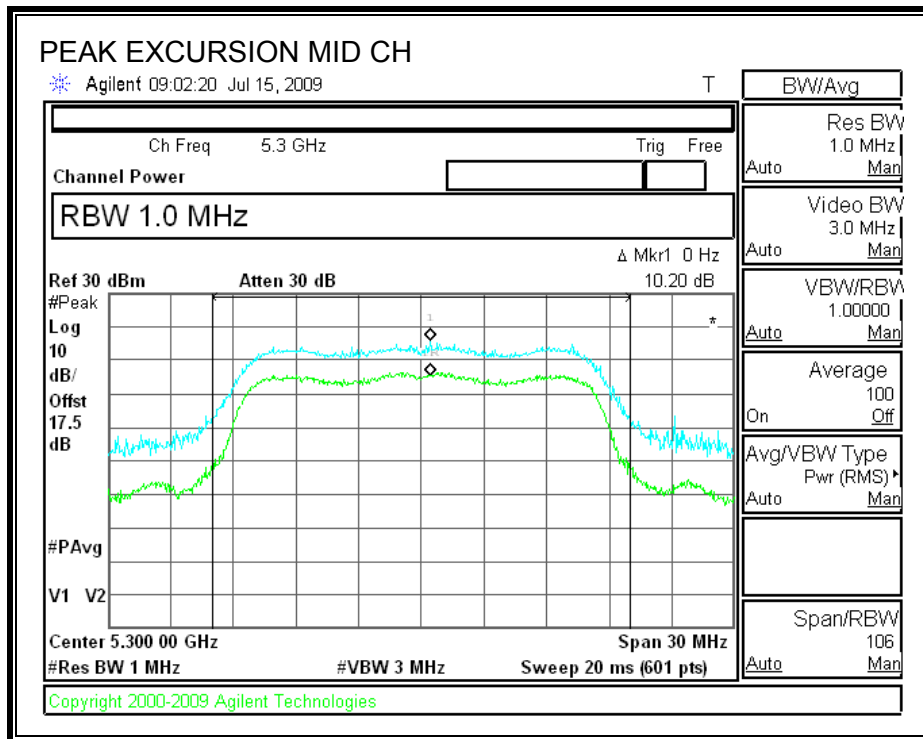
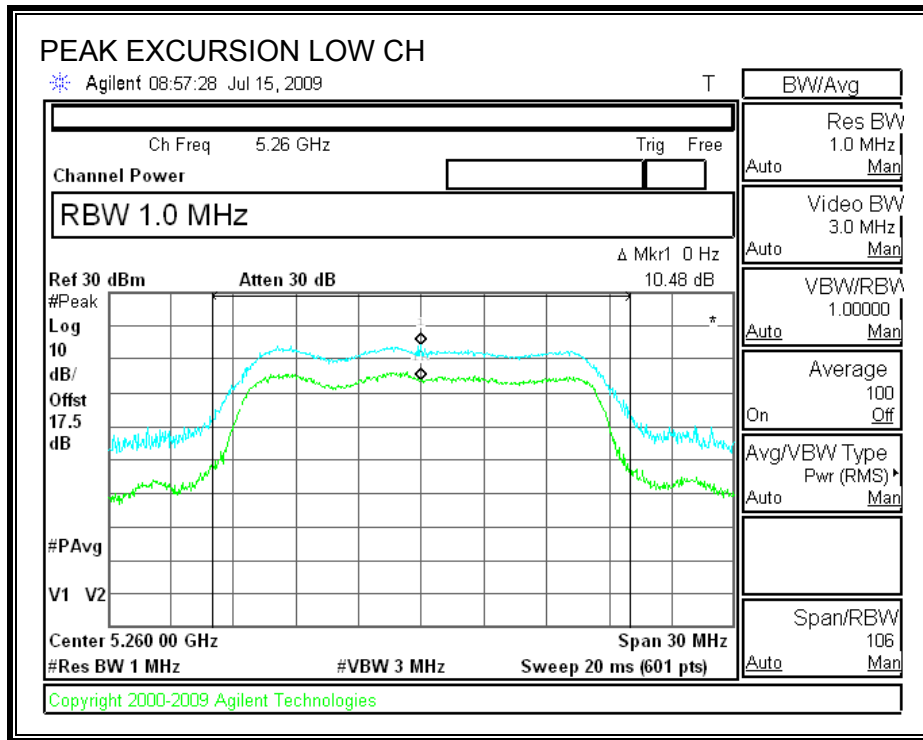

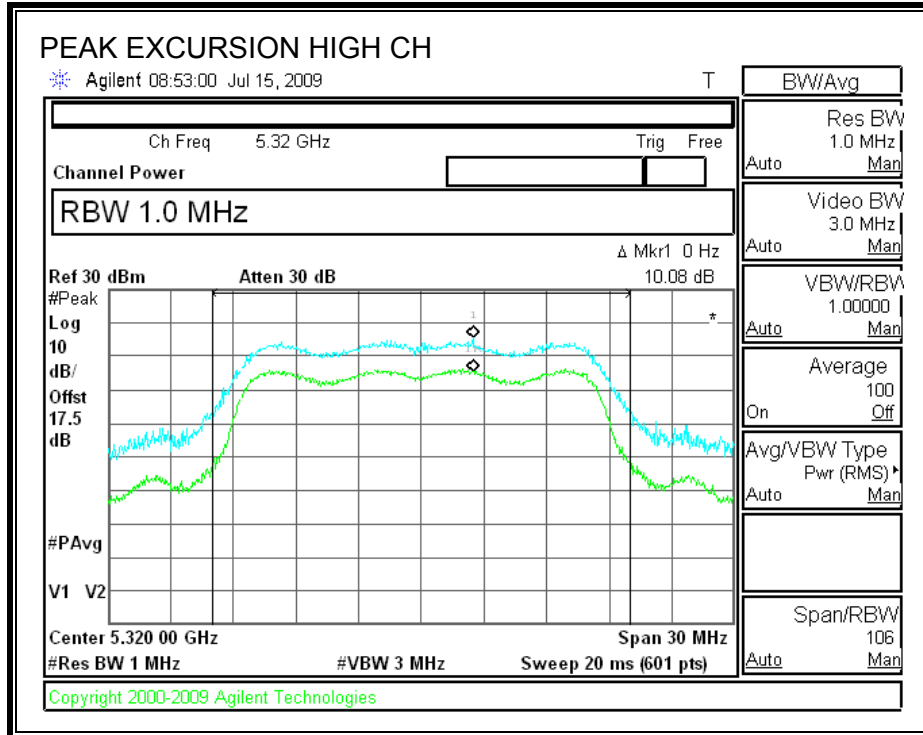

7.4.6. CONDUCTED SPURIOUS EMISSIONS

LIMITS

FCC §15.407 (b) (1)

IC RSS-210 A9.3 (1)

For transmitters operating in the 5.25-5.35 GHz band: all emissions outside of the 5.25-5.35 GHz band shall not exceed an EIRP of -27 dBm / MHz.

TEST PROCEDURE

Conducted RF measurements of the transmitter output are made to confirm that the EUT antenna port conducted emissions meet the specified limit and to identify any spurious signals that require further investigation or measurements on the radiated emissions site.

The transmitter output is connected to the spectrum analyzer. The resolution bandwidth is set to 1 MHz. The video bandwidth is set to 1 MHz. Peak detection measurements are compared to EIRP limit, adjusted for the maximum antenna gain.

Measurements are made over the 30 MHz to 40 GHz range with the transmitter set to the lowest, middle, and highest channels.

SPURIOUS EMISSIONS WITH COMBINER

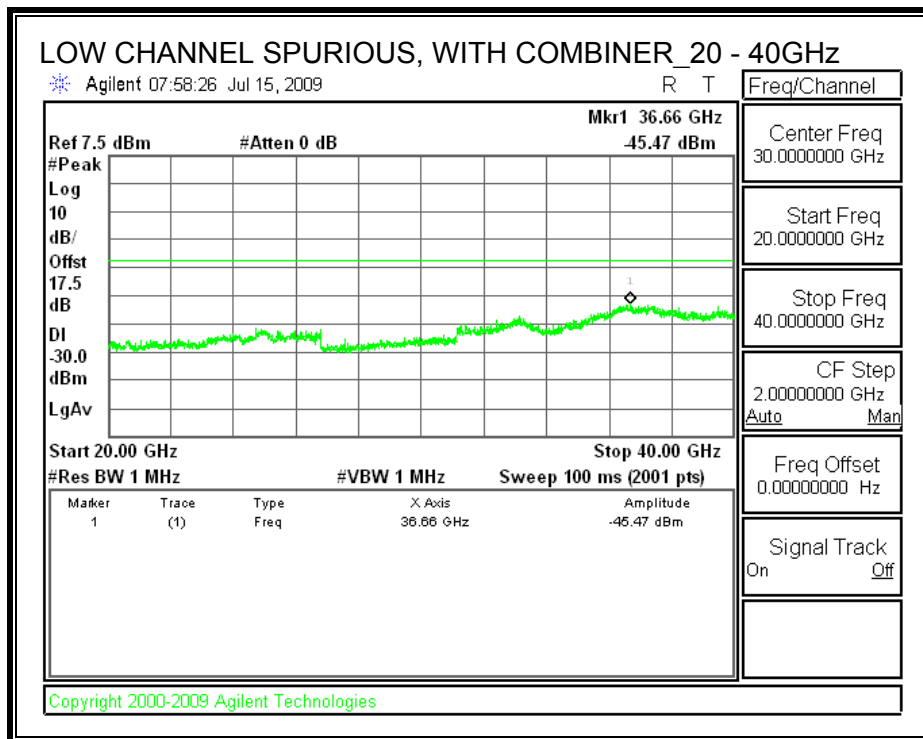
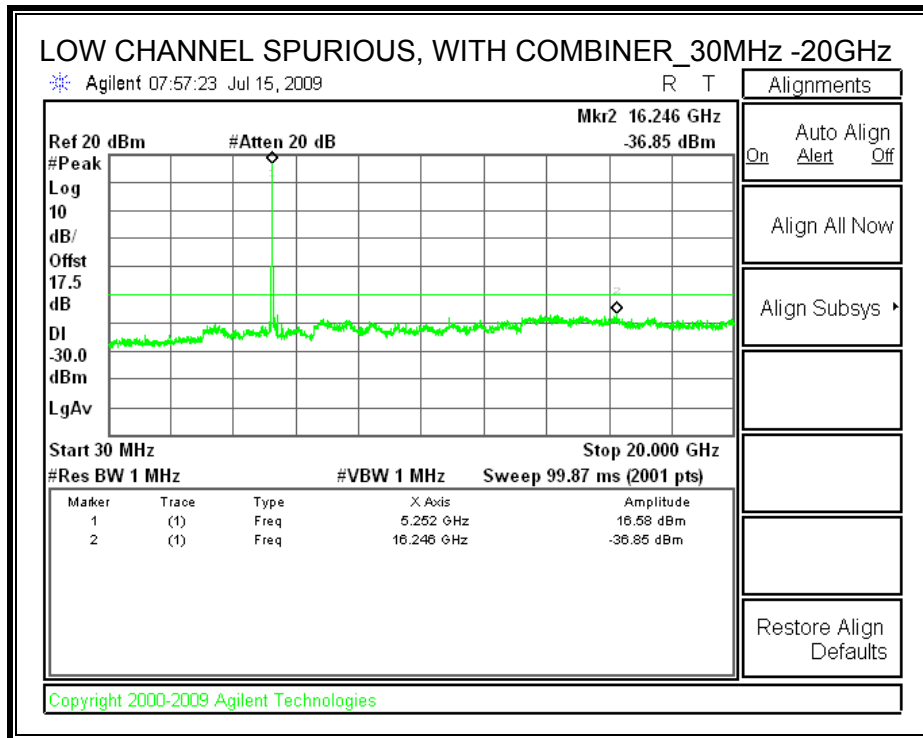

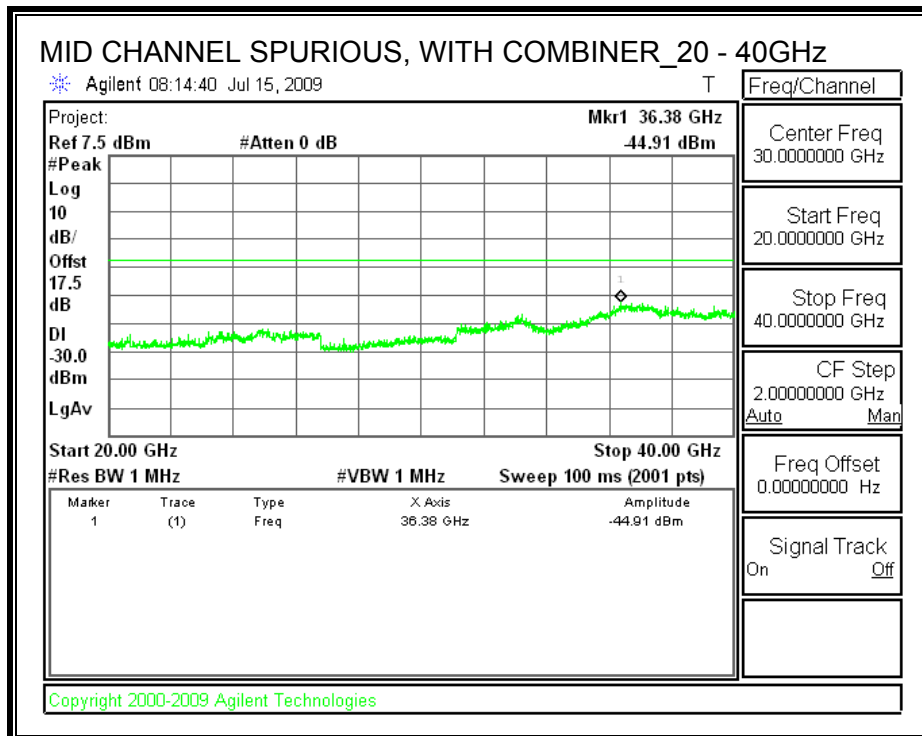
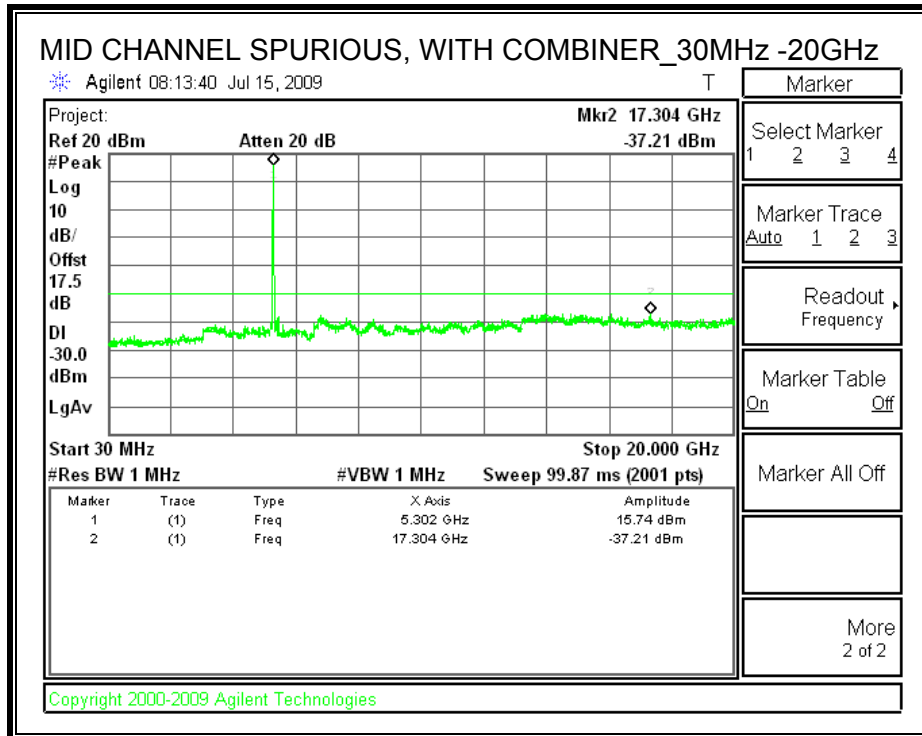

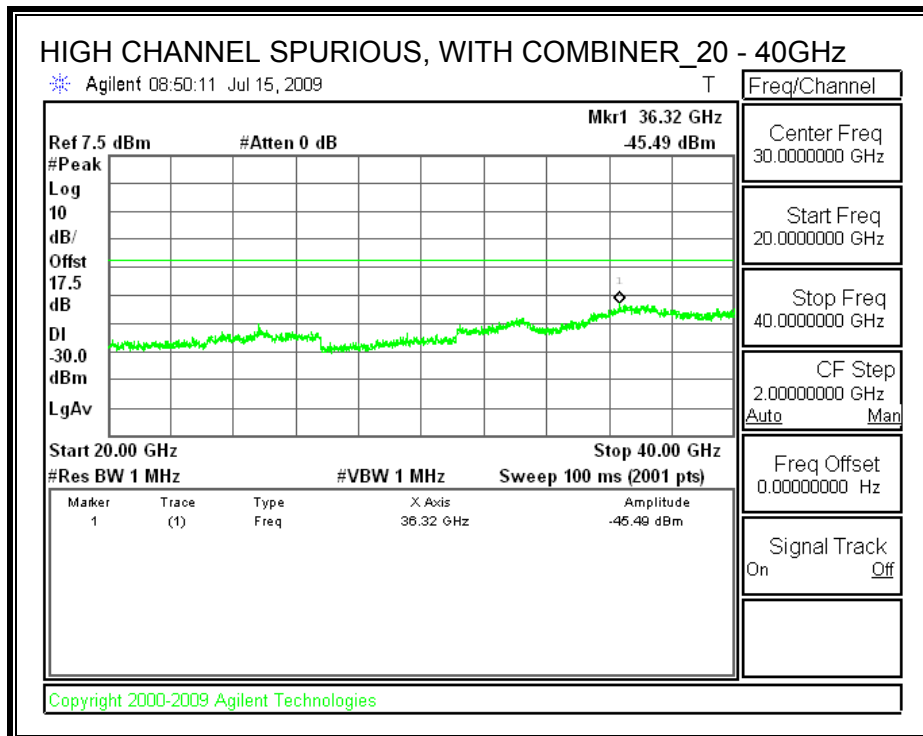
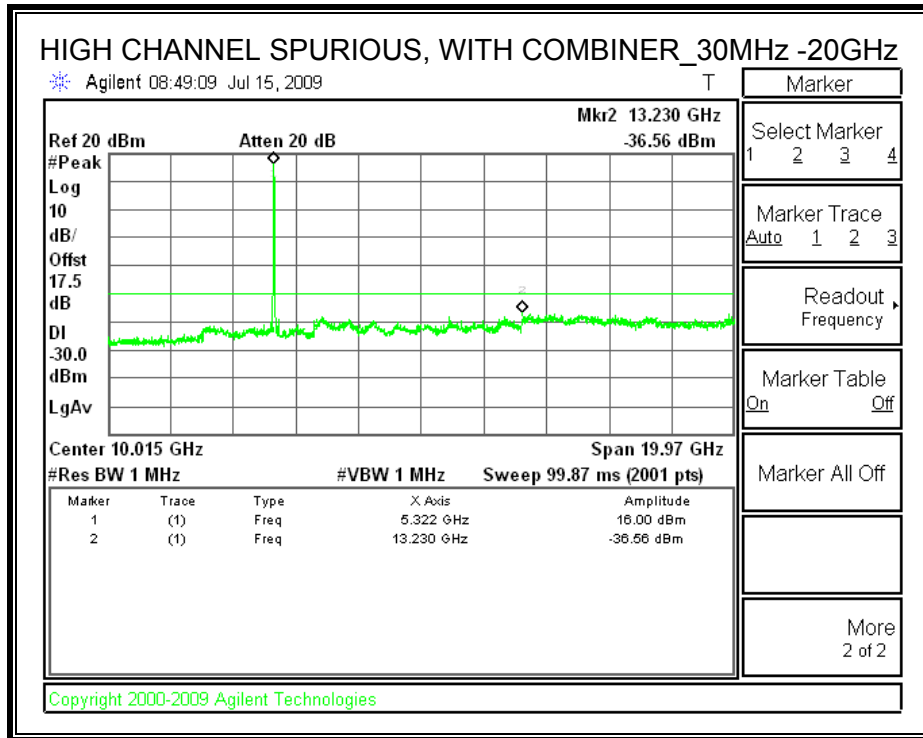

7.5. 5.3 GHz BAND CHANNEL TESTS FOR 802.11n HT20 MODE

7.5.1. 99% & 26 dB BANDWIDTH

LIMITS

None; for reporting purposes only.

TEST PROCEDURE

The transmitter output is connected to the spectrum analyzer. The RBW is set to 1% to 3% of the bandwidth. The VBW is set to 3 times the RBW. The sweep time is coupled. The spectrum analyzer internal bandwidth measurement function is utilized.

RESULTS

Channel	Frequency (MHz)	99% OBW (MHz)	26 dB BW (MHz)
Low	5260	17.3966	18.521
Middle	5300	17.2296	18.201
High	5320	17.3380	18.517

99% & 26 dB BANDWIDTH

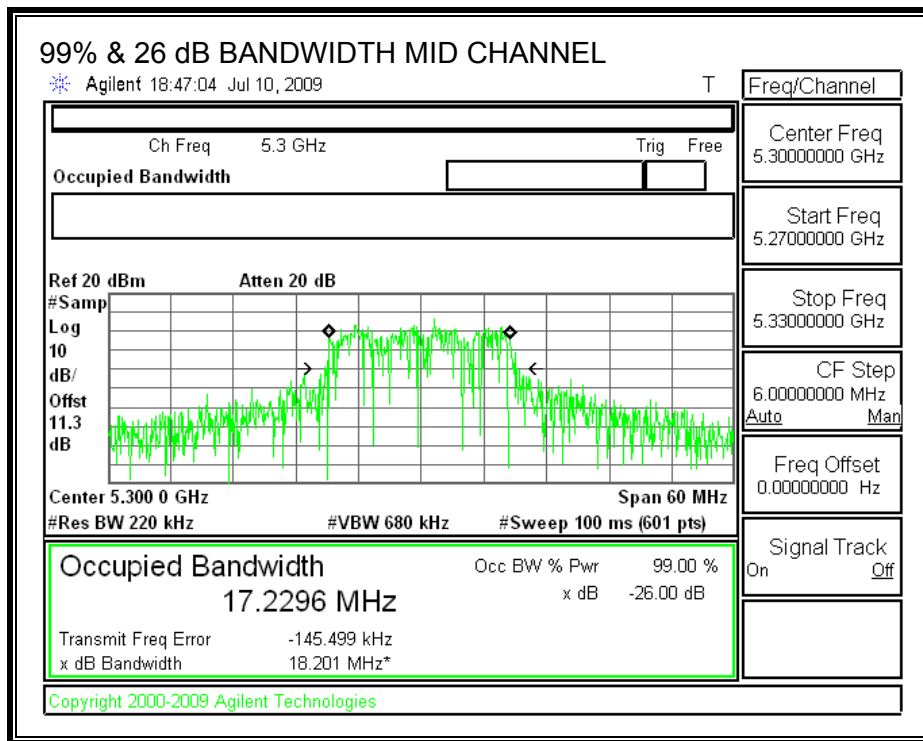
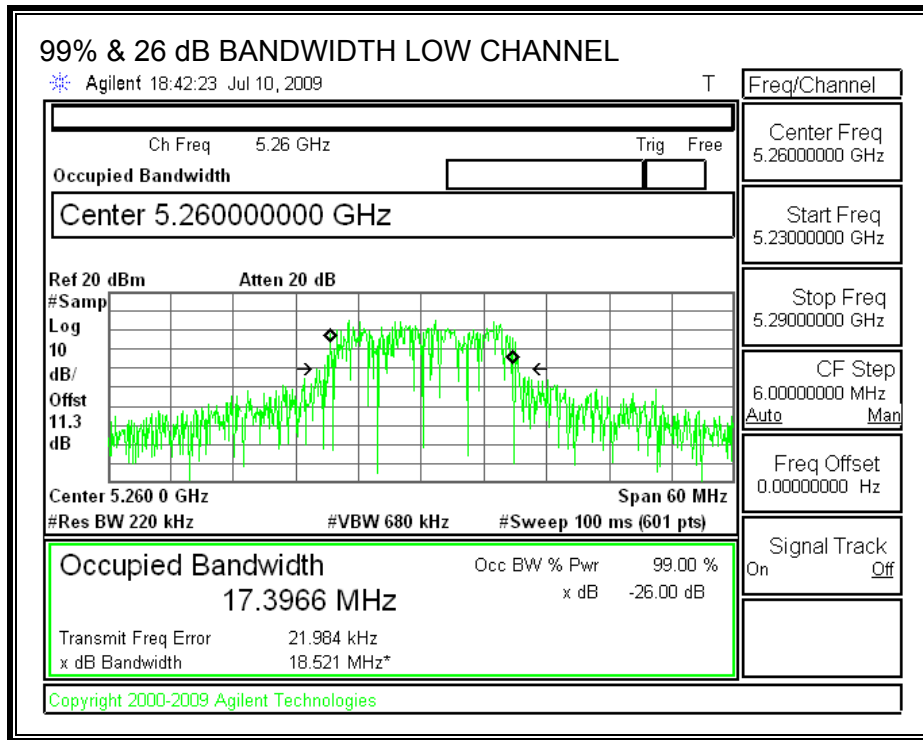

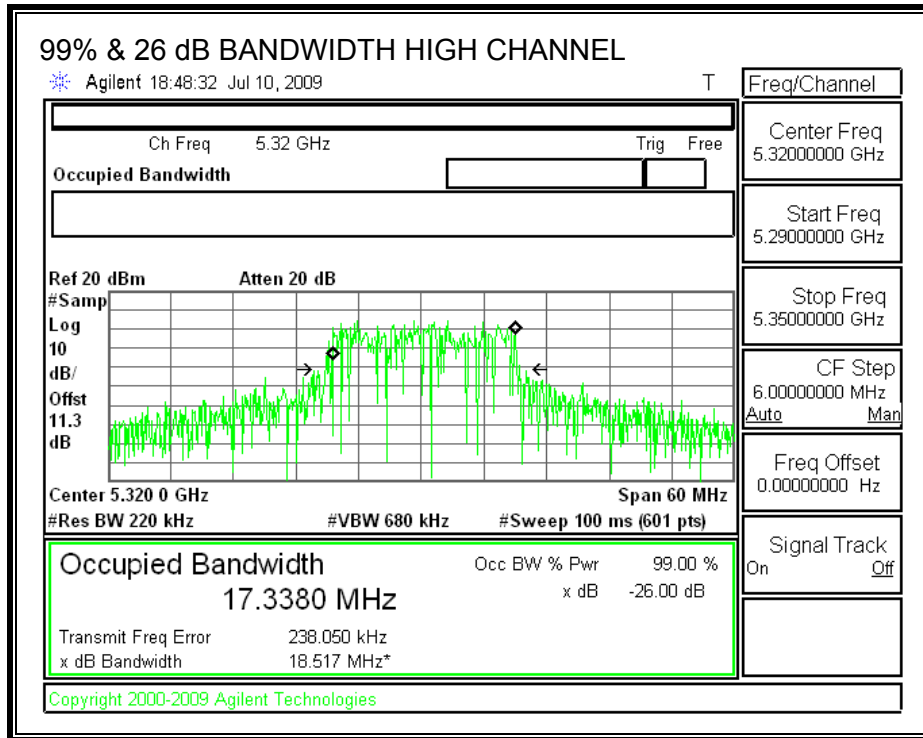

7.5.2. OUTPUT POWER

LIMITS

FCC §15.407 (a) (2)

IC RSS-210 A9.2 (2)

For the 5.25-5.35 GHz band, the maximum conducted output power over the frequency band of operation shall not exceed the lesser of 250 mW or 11 dBm + 10 log B, where B is the 26-dB emission bandwidth in MHz. If transmitting antennas of directional gain greater than 6 dBi are used, both the peak transmit power and the peak power spectral density shall be reduced by the amount in dB that the directional gain of the antenna exceeds 6 dBi.

TEST PROCEDURE

The test is performed in accordance with FCC Public Notice: APPENDIX A Guidelines for Assessing Unlicensed National Information Infrastructure (U-NII) Devices – Part 15, Subpart E, August 2002.

The transmitter output operates continuously therefore Method # 1 is used.

RESULTS

Limit

Channel	Freq (MHz)	Fixed Limit (dBm)	B (MHz)	4 + 10 Log B Limit (dBm)	Antenna Gain (dBi)	Limit (dBm)
Low	5260	24	18.520	23.68	3	23.68
Mid	5300	24	18.201	23.60	3	23.60
High	5320	24	18.517	23.68	3	23.68

Individual Chain Results

Channel	Freq (MHz)	Chain 0 Power (dBm)	Chain 1 Power (dBm)	Chain 2 Power (dBm)	Chain 3 Power (dBm)	Total Power (dBm)	Limit (dBm)	Margin (dB)
Low	5260	14.45	14.59	14.46	14.52	20.53	23.68	-3.15
Mid	5300	14.23	14.40	14.49	14.62	20.46	23.60	-3.14
High	5320	14.67	14.59	14.69	14.57	20.65	23.68	-3.02

OUTPUT POWER, LOW CHANNEL

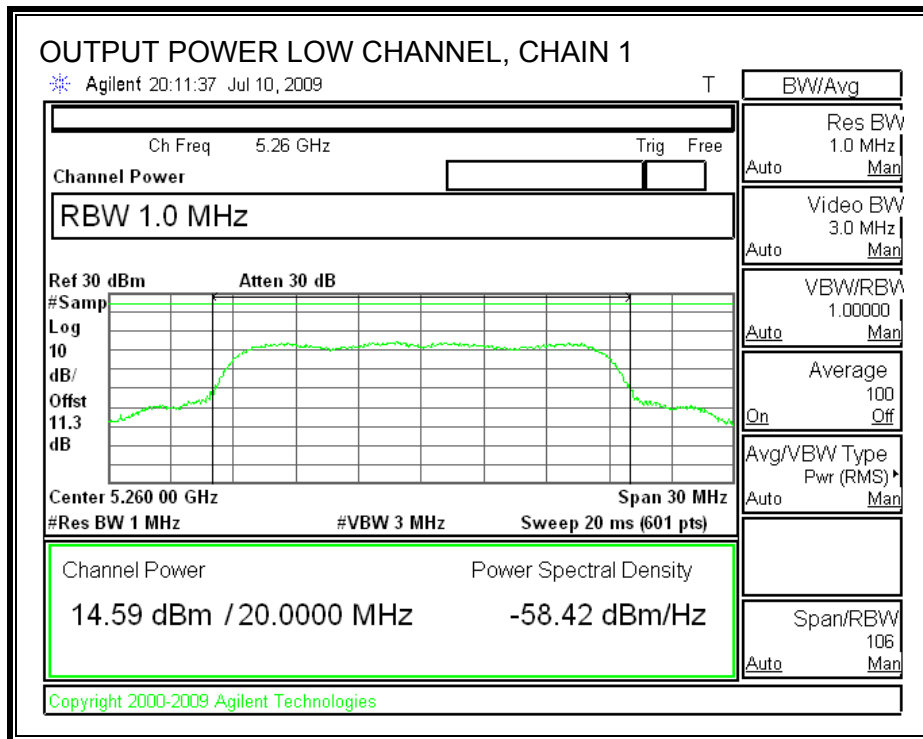
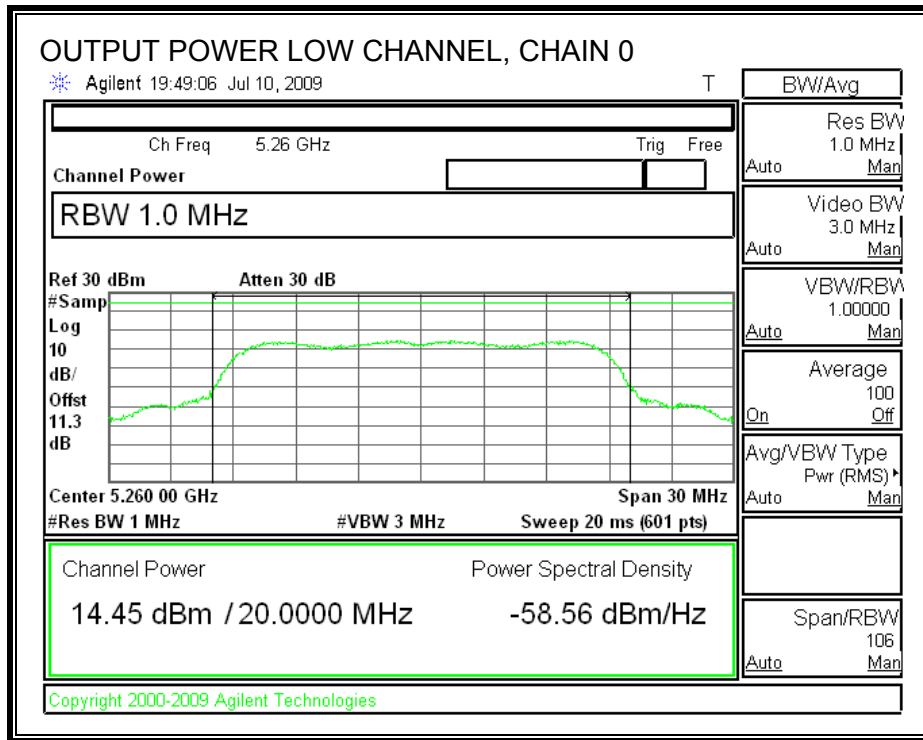

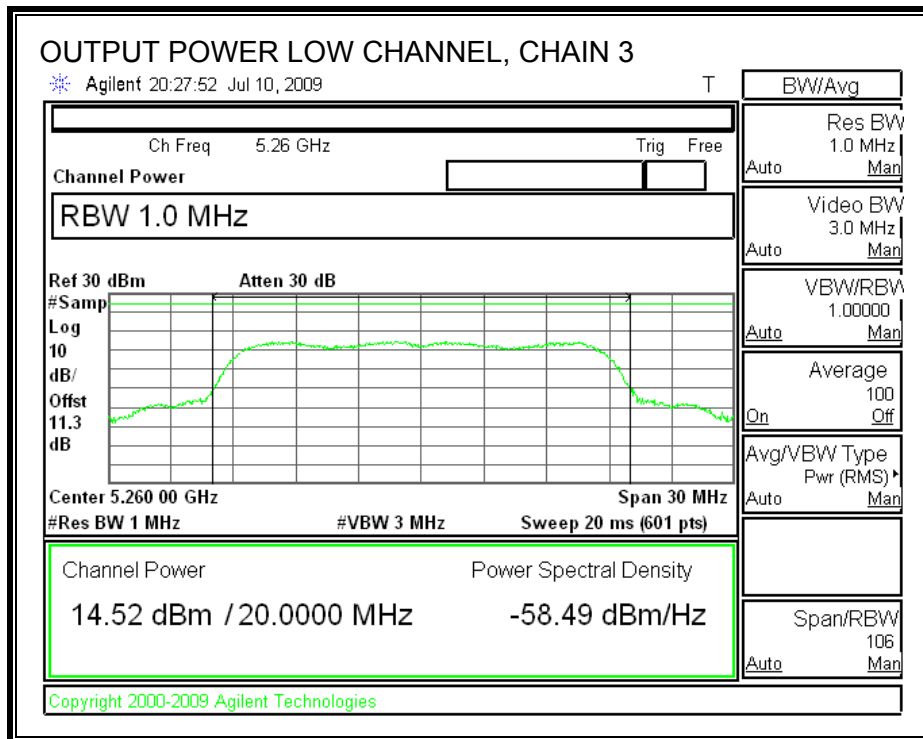
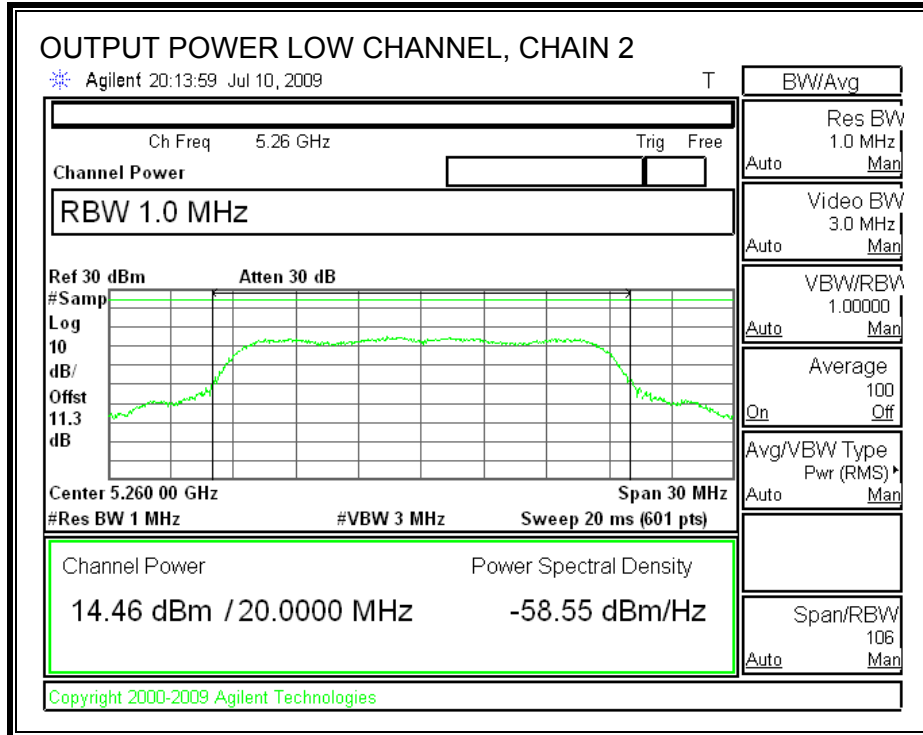

OUTPUT POWER, MID CHANNEL

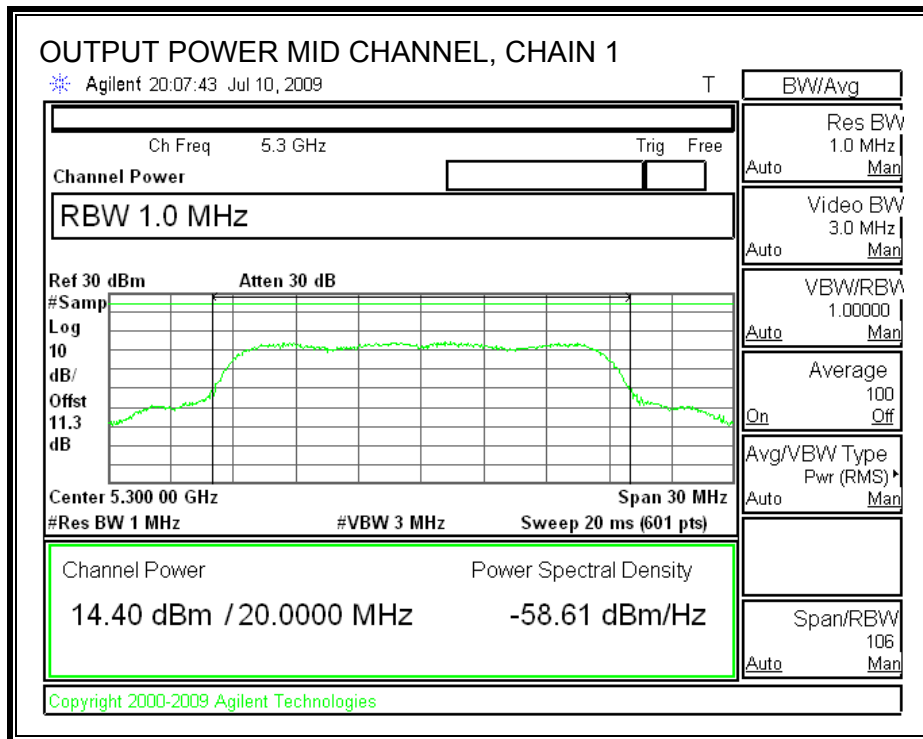
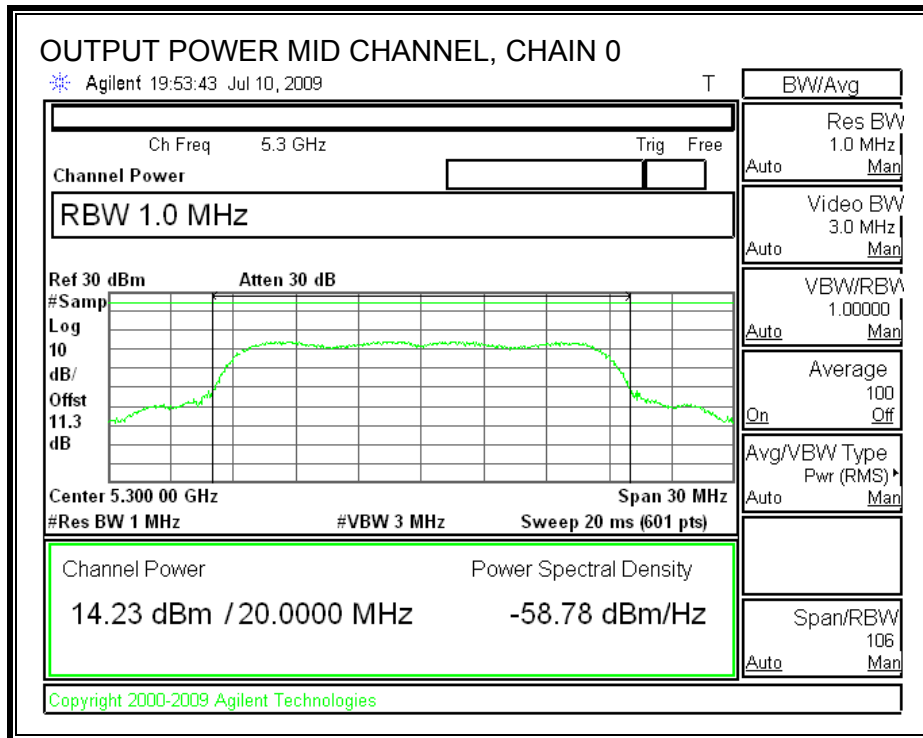

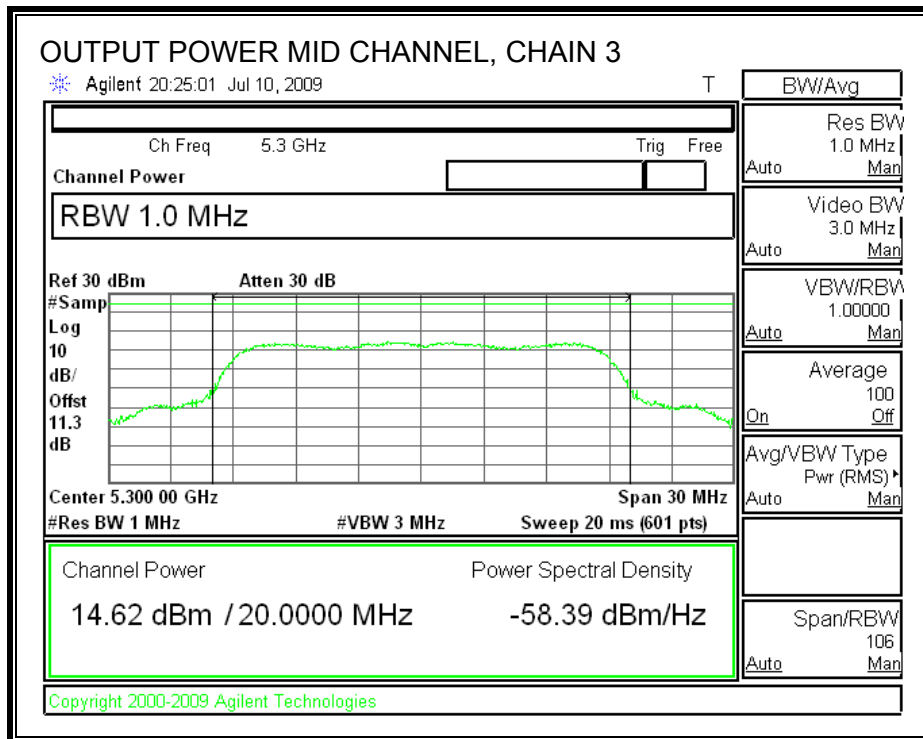
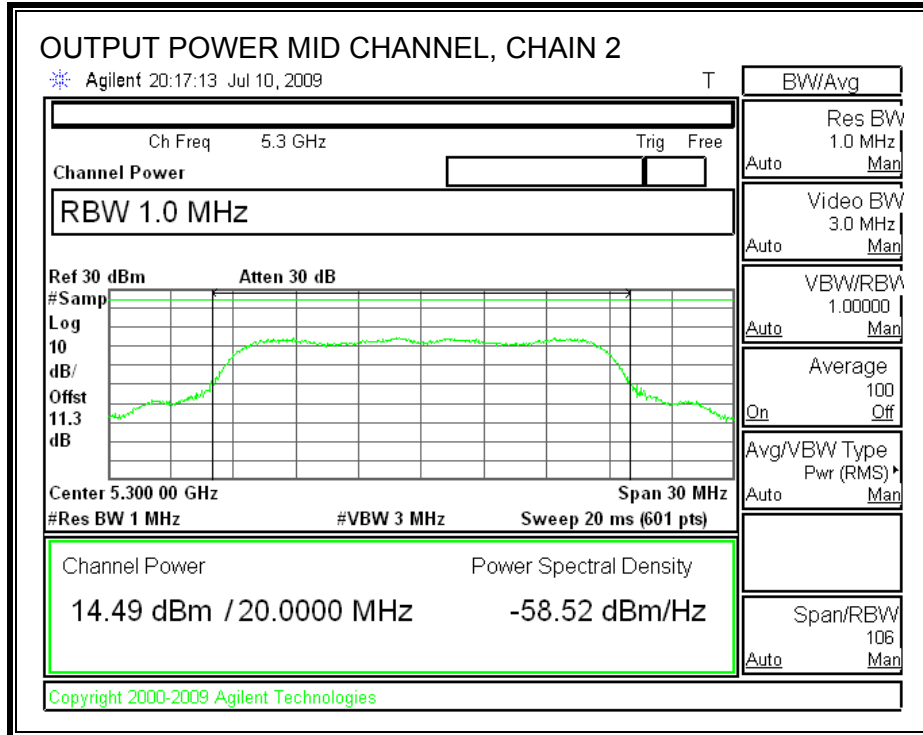

OUTPUT POWER, HIGH CHANNEL

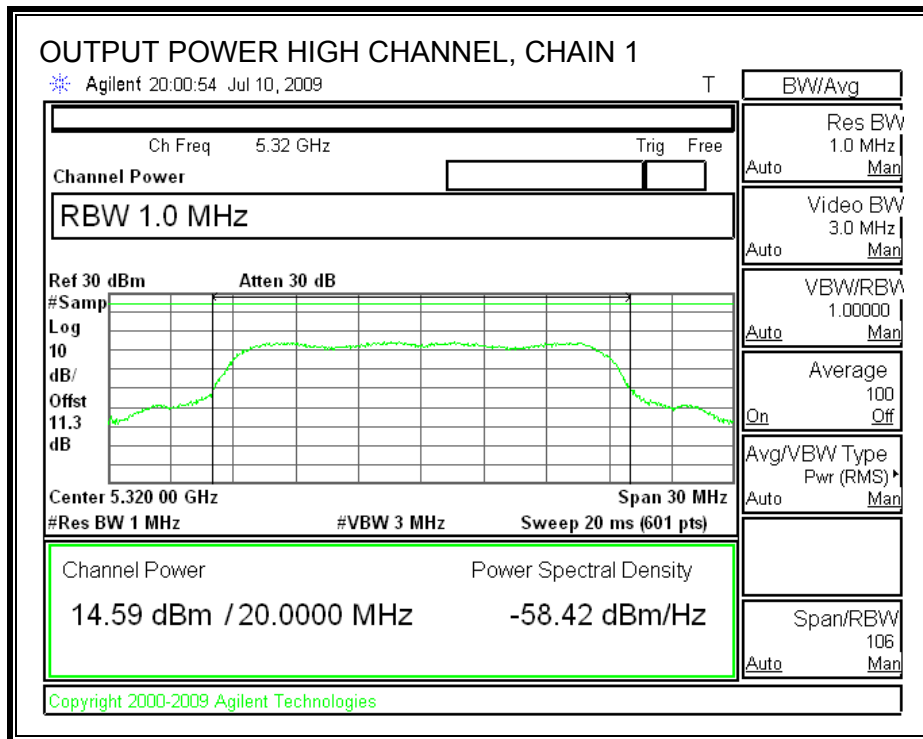
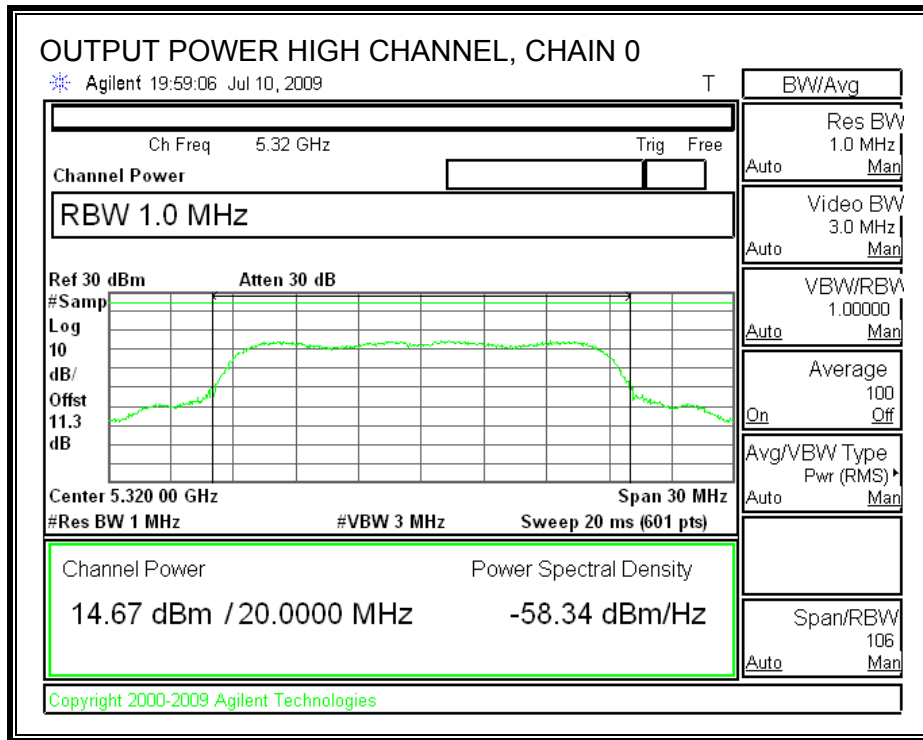

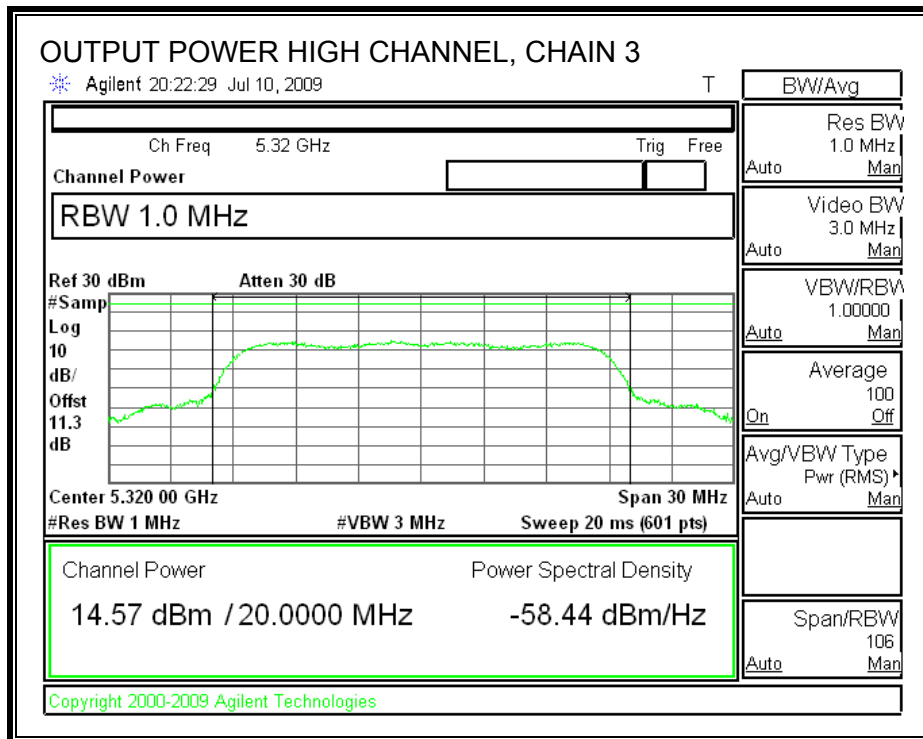
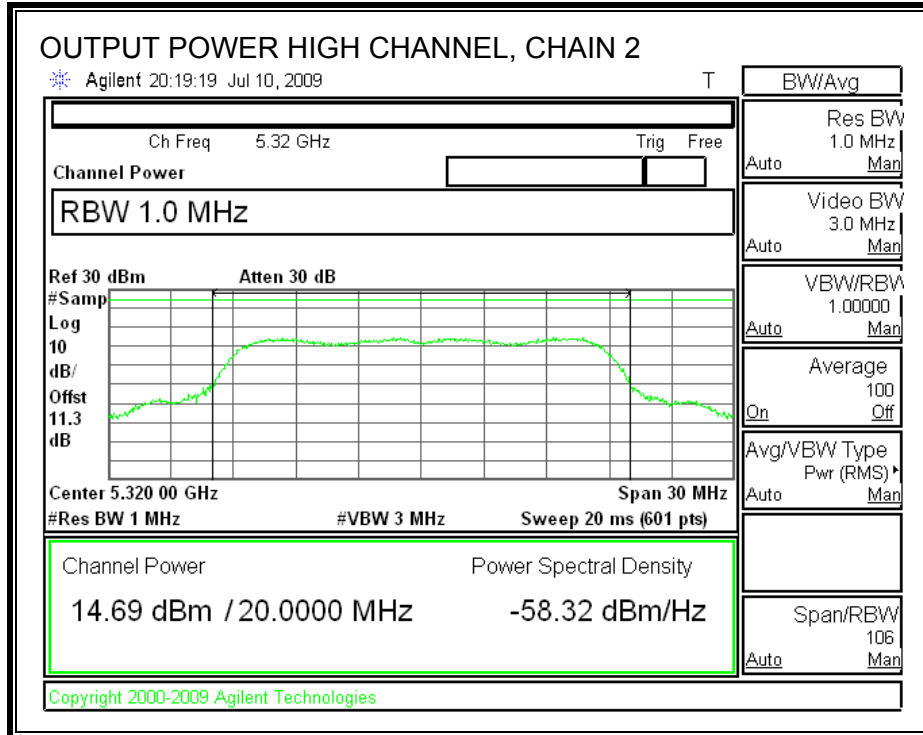

7.5.3. AVERAGE POWER

LIMITS

None; for reporting purposes only.

TEST PROCEDURE

The transmitter output is connected to a power meter.

The cable assembly insertion loss of 11.3 dB (including 10 dB pad and 1.3 dB cable) was entered as an offset in the power meter to allow for direct reading of power.

RESULTS

Frequency (MHz)	Chain 0 Power (dBm)	Chain 1 Power (dBm)	Chain 2 Power (dBm)	Chain 3 Power (dBm)
5260	14.64	14.56	14.45	14.74
5300	14.44	14.53	14.51	14.64
5320	14.50	14.54	14.65	14.66

7.5.4. PEAK POWER SPECTRAL DENSITY

LIMITS

FCC §15.407 (a) (2)

IC RSS-210 A9.2 (2)

For the 5.25-5.35 GHz band, the peak power spectral density shall not exceed 11 dBm in any 1 MHz band. If transmitting antennas of directional gain greater than 6 dBi are used, both the peak transmit power and the peak power spectral density shall be reduced by the amount in dB that the directional gain of the antenna exceeds 6 dBi.

The maximum antenna gain is less than 6 dBi; therefore the limit is 11 dBm.

TEST PROCEDURE

The test is performed in accordance with FCC Public Notice: APPENDIX A Guidelines for Assessing Unlicensed National Information Infrastructure (U-NII) Devices – Part 15, Subpart E, August 2002. PPSD method #2 was used.

Preliminary tests on individual chains, and on all chains with a combiner, were performed. The worst-case configuration was with a combiner, therefore final test were performed with all chains feeding a combiner.

RESULTS

Channel	Frequency (MHz)	PSD with Combiner (dBm)	Limit (dBm)	Margin (dB)
Low	5260	10.57	11	-0.43
Middle	5300	10.43	11	-0.57
High	5320	10.78	11	-0.22

POWER SPECTRAL DENSITY

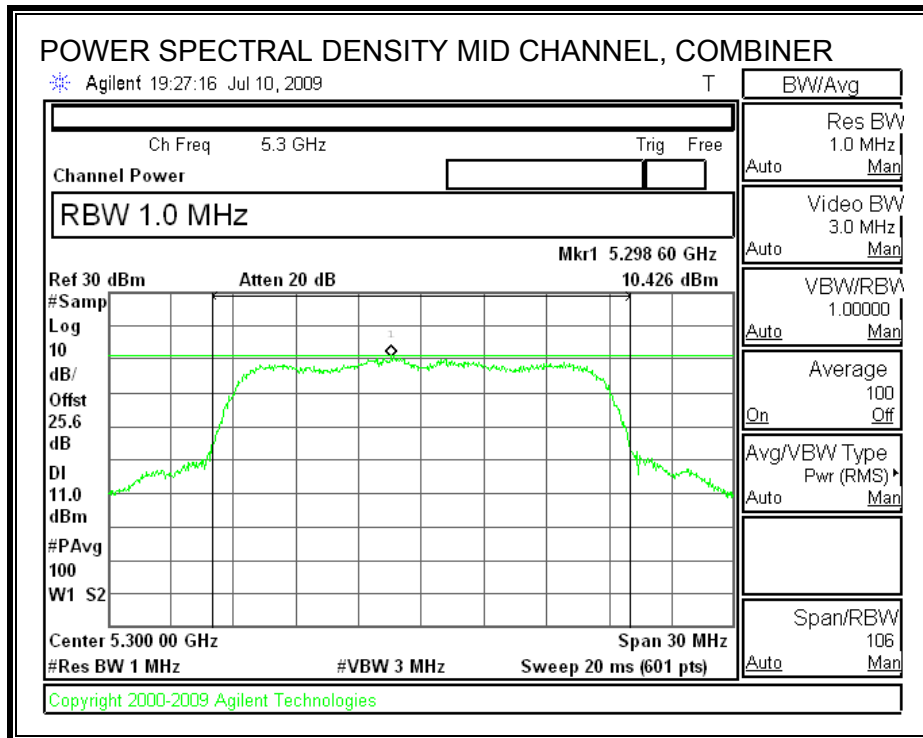
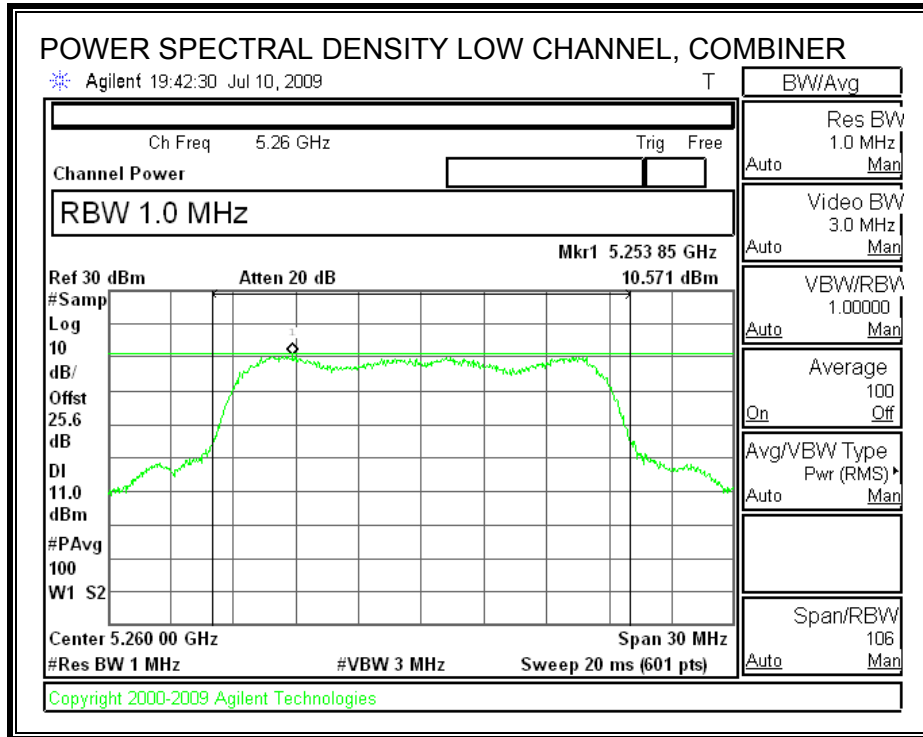

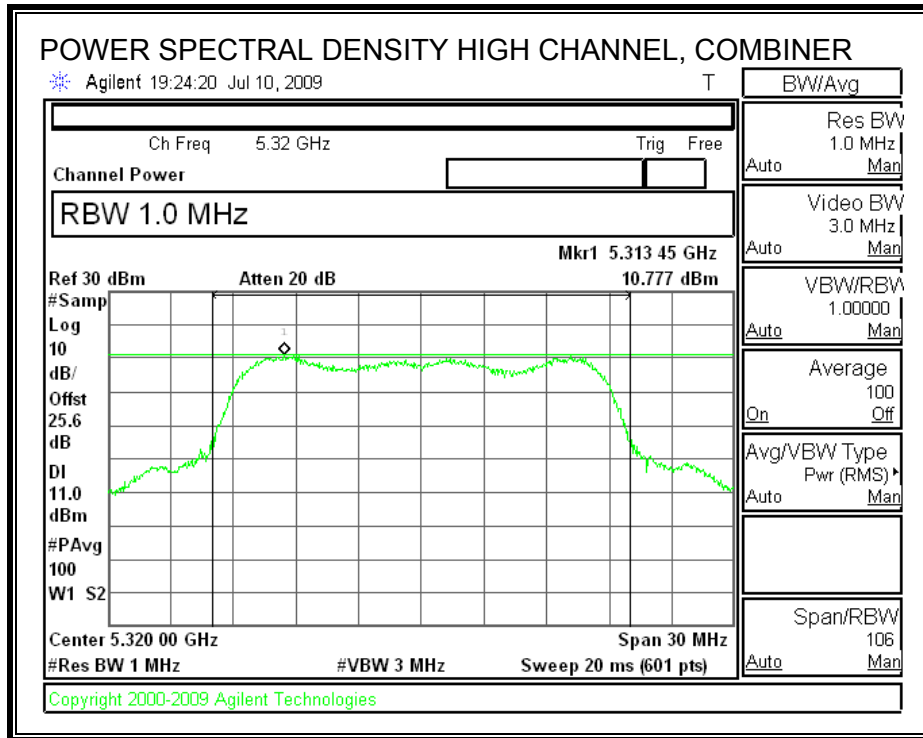

7.5.5. PEAK EXCURSION

LIMITS

FCC §15.407 (a) (6)

The ratio of the peak excursion of the modulation envelope (measured using a peak hold function) to the peak transmit power (measured as specified above) shall not exceed 13 dB across any 1 MHz bandwidth or the emission bandwidth whichever is less.

TEST PROCEDURE

The transmitter outputs are connected to the spectrum analyzer via a combiner.

The test is performed in accordance with FCC Public Notice: APPENDIX A Guidelines for Assessing Unlicensed National Information Infrastructure (U-NII) Devices – Part 15, Subpart E, August 2002.

Since Method # 1 was used for peak power measurements, Method # 1 settings are used for the second PPSD trace.

RESULTS

Channel	Frequency (MHz)	Peak Excursion (dB)	Limit (dB)	Margin (dB)
Low	5260	9.14	13	-3.86
Middle	5300	10.56	13	-2.44
High	5320	8.87	13	-4.13

PEAK EXCURSION

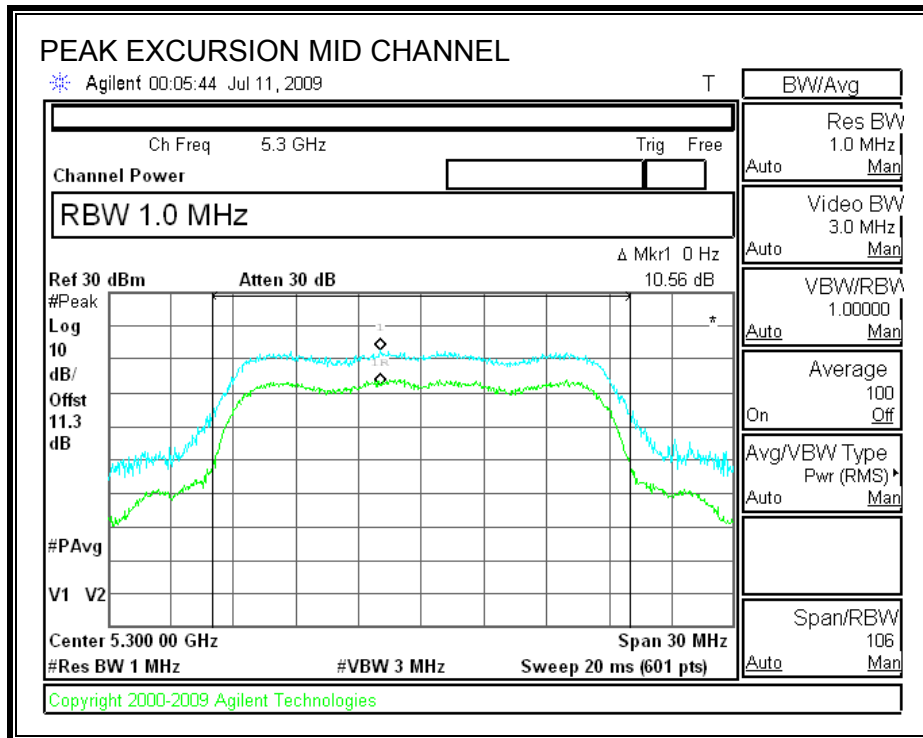
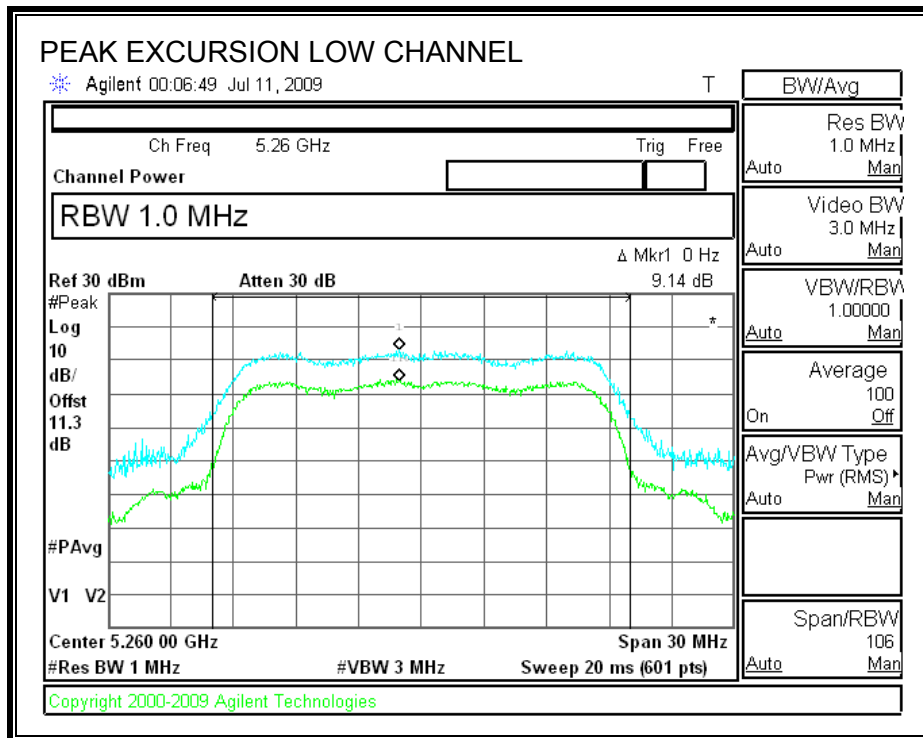

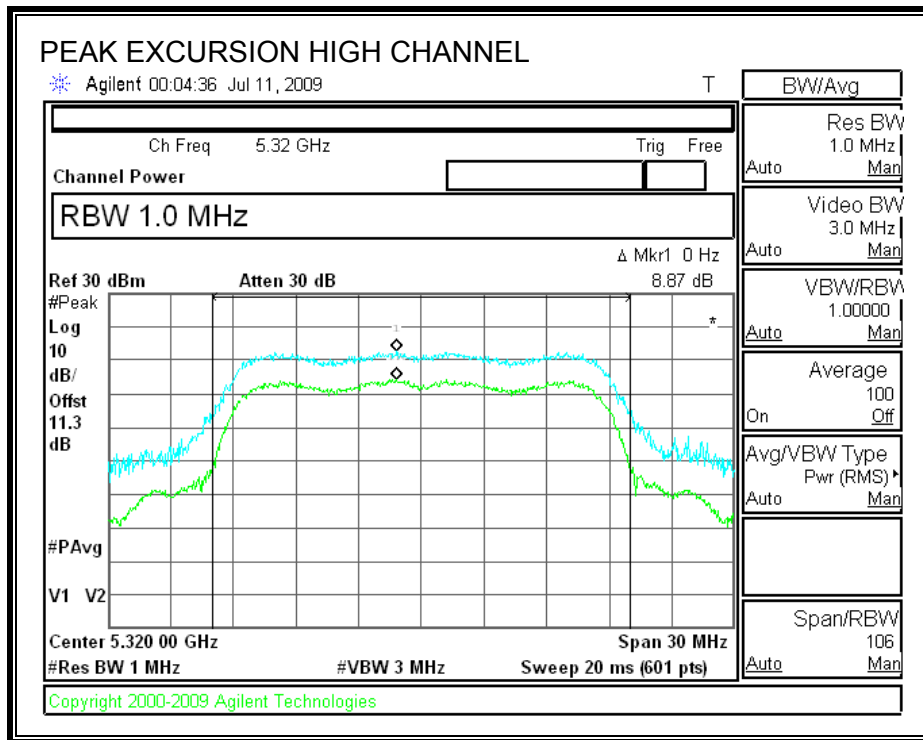

7.5.6. CONDUCTED SPURIOUS EMISSIONS

LIMITS

FCC §15.407 (b) (3)

IC RSS-210 A9.3 (3)

For transmitters operating in the 5.25-5.35 GHz band: all emissions outside of the 5.25-5.35 GHz band shall not exceed an EIRP of -27 dBm / MHz.

Devices operating in the 5.25-5.35 GHz band that generate emissions in the 5.15-5.25 GHz band must meet all applicable technical requirements for operation in the 5.15-5.25 GHz band (including indoor use) or alternatively meet an out-of-band emission EIRP limit of -27 dBm/MHz in the 5.15-5.25 GHz band.

TEST PROCEDURE

Conducted RF measurements of the transmitter output are made to confirm that the EUT antenna port conducted emissions meet the specified limit and to identify any spurious signals that require further investigation or measurements on the radiated emissions site.

The transmitter output is connected to the spectrum analyzer. The resolution bandwidth is set to 1 MHz. The video bandwidth is set to 1 MHz. Peak detection measurements are compared to EIRP limit, adjusted for the maximum antenna gain.

Measurements are made over the 30 MHz to 40 GHz range with the transmitter set to the lowest, middle, and highest channels.

Preliminary tests on individual chains, and on all chains with a combiner, were performed. The worst-case configuration was with a combiner, therefore final test were performed with all chains feeding a combiner.

LOW CHANNEL SPURIOUS EMISSIONS

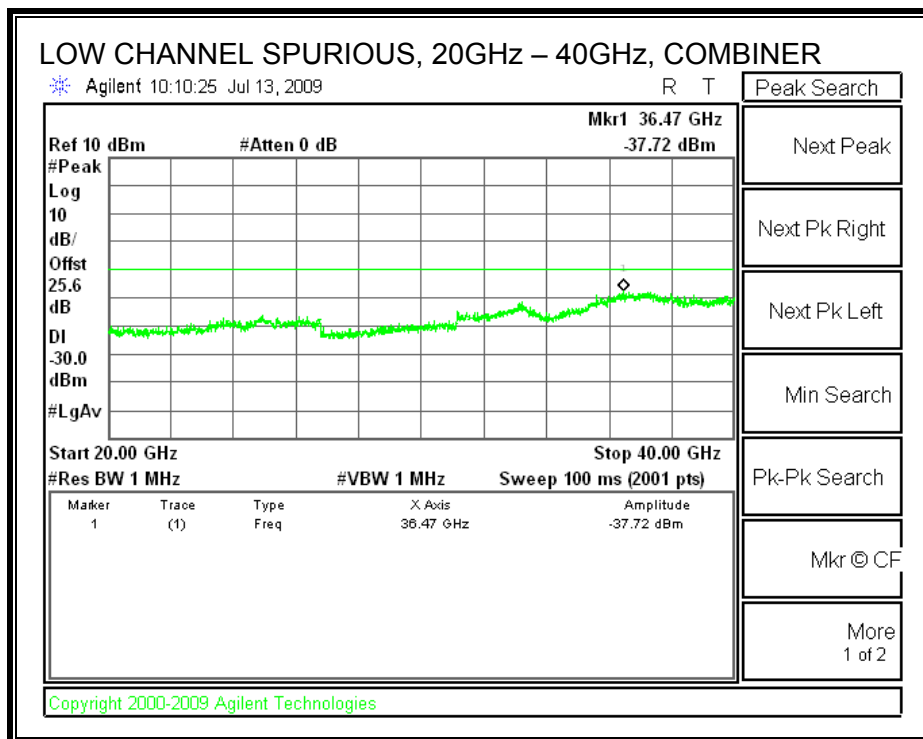
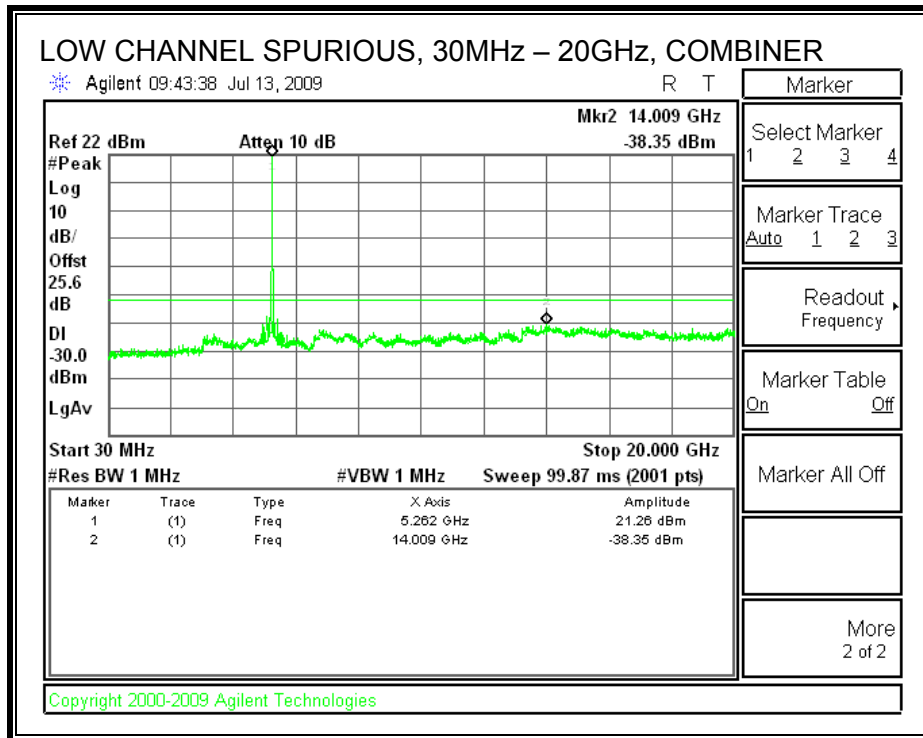

MID CHANNEL SPURIOUS EMISSIONS

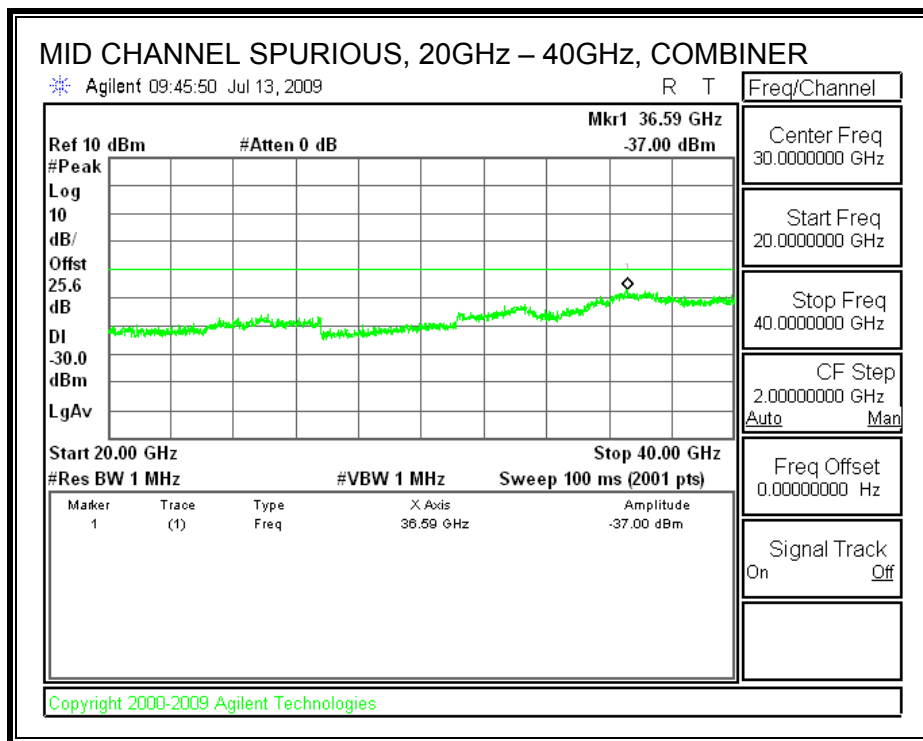
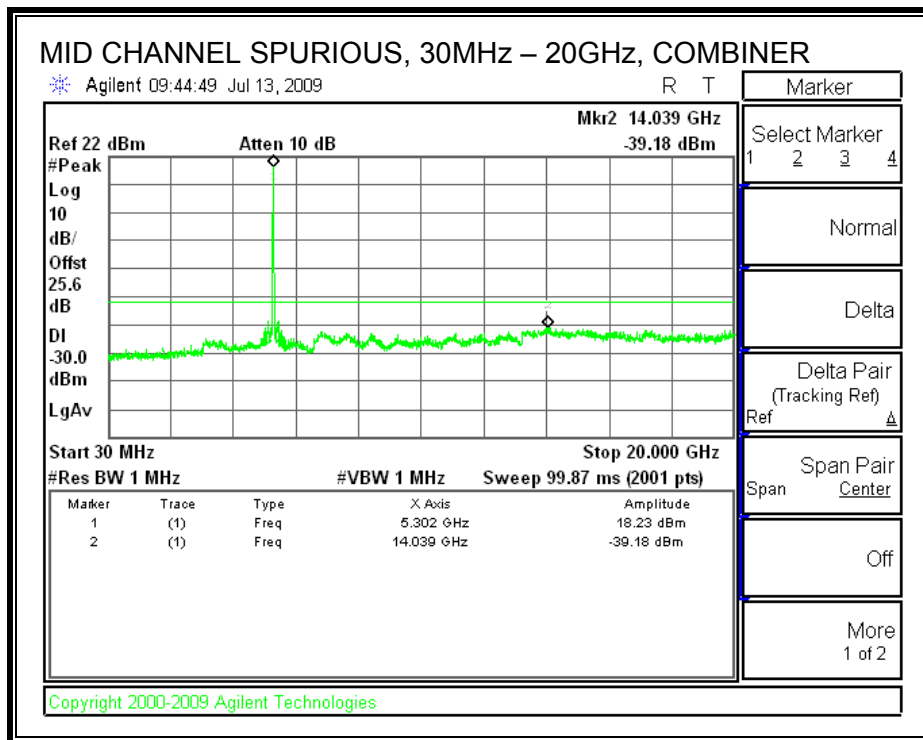

HIGH CHANNEL SPURIOUS EMISSIONS

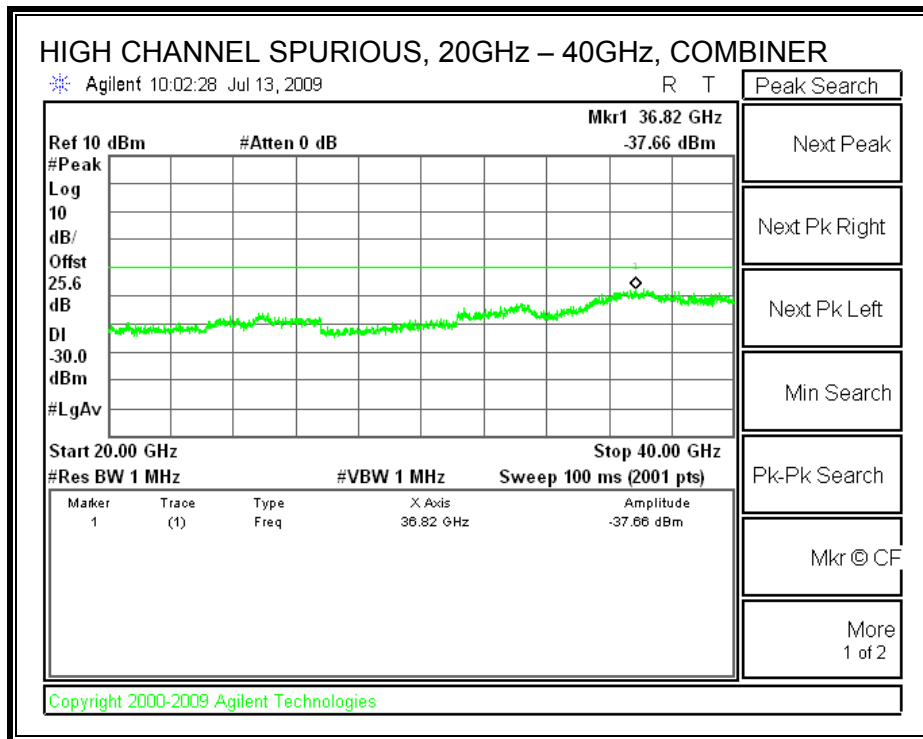
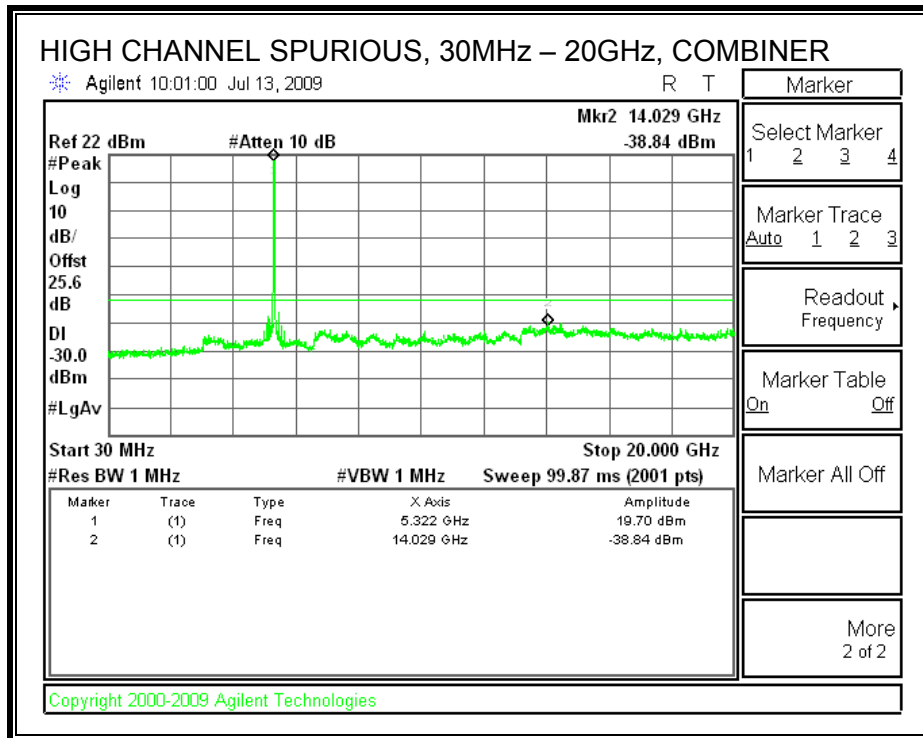

7.6. 5.3 GHz BAND CHANNEL TESTS FOR 802.11n HT40 MODE

7.6.1. 99% & 26 dB BANDWIDTH

LIMITS

None; for reporting purposes only.

TEST PROCEDURE

The transmitter output is connected to the spectrum analyzer. The RBW is set to 1% to 3% of the bandwidth. The VBW is set to 3 times the RBW. The sweep time is coupled. The spectrum analyzer internal bandwidth measurement function is utilized.

RESULTS

Channel	Frequency (MHz)	99% OBW (MHz)	26 dB BW (MHz)
Low	5270	35.503	39.030
High	5310	35.867	37.688

99% & 26 dB BANDWIDTH

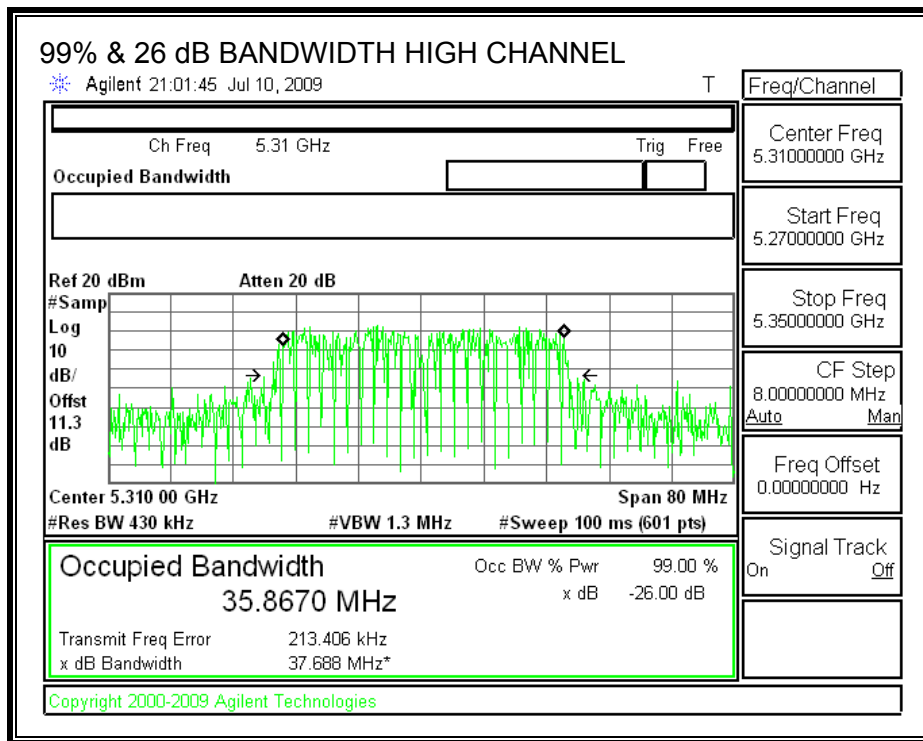
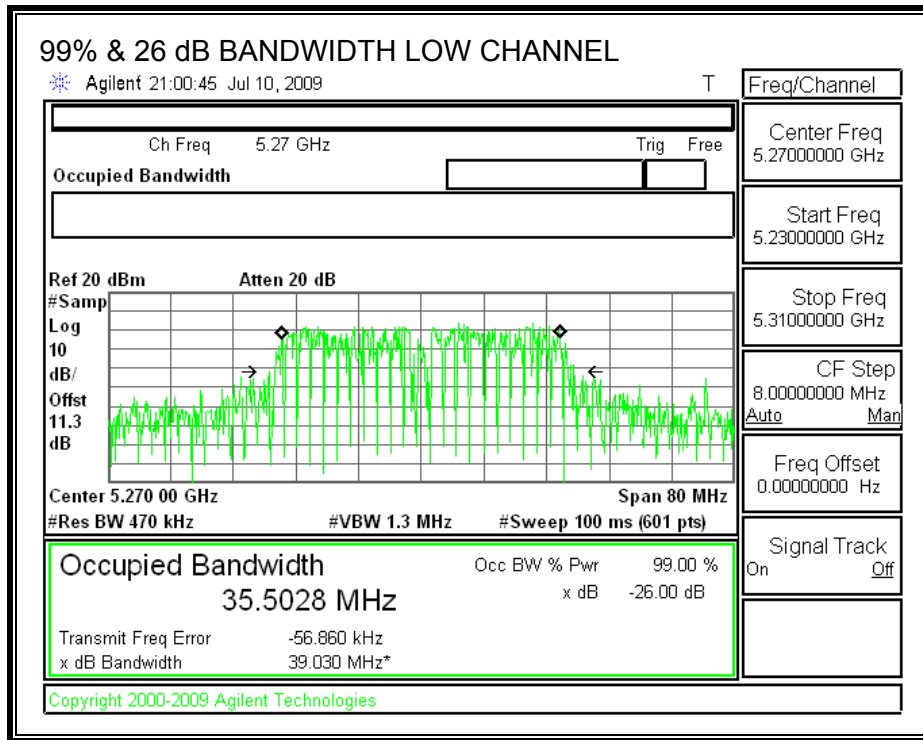

7.6.2. OUTPUT POWER

LIMITS

FCC §15.407 (a) (2)

IC RSS-210 A9.2 (2)

For the 5.25-5.35 GHz band, the maximum conducted output power over the frequency band of operation shall not exceed the lesser of 250 mW or 11 dBm + 10 log B, where B is the 26-dB emission bandwidth in MHz. If transmitting antennas of directional gain greater than 6 dBi are used, both the peak transmit power and the peak power spectral density shall be reduced by the amount in dB that the directional gain of the antenna exceeds 6 dBi.

TEST PROCEDURE

The test is performed in accordance with FCC Public Notice: APPENDIX A Guidelines for Assessing Unlicensed National Information Infrastructure (U-NII) Devices – Part 15, Subpart E, August 2002.

The transmitter output operates continuously therefore Method # 1 is used.

RESULTS

Limit

Channel	Freq (MHz)	Fixed Limit (dBm)	B (MHz)	11 + 10 Log B Limit (dBm)	Antenna Gain (dBi)	Limit (dBm)
Low	5270	24	39.03	26.91	3	24.00
High	5310	24	37.688	26.76	3	24.00

Individual Chain Results

Channel	Freq (MHz)	Chain 0 Power (dBm)	Chain 1 Power (dBm)	Chain 2 Power (dBm)	Chain 3 Power (dBm)	Total Power (dBm)	Limit (dBm)	Margin (dB)
Low	5270	16.96	17.64	17.14	17.12	23.24	24.00	-0.76
High	5310	12.14	12.46	11.86	12.15	18.18	24.00	-5.82

OUTPUT POWER, LOW CHANNEL

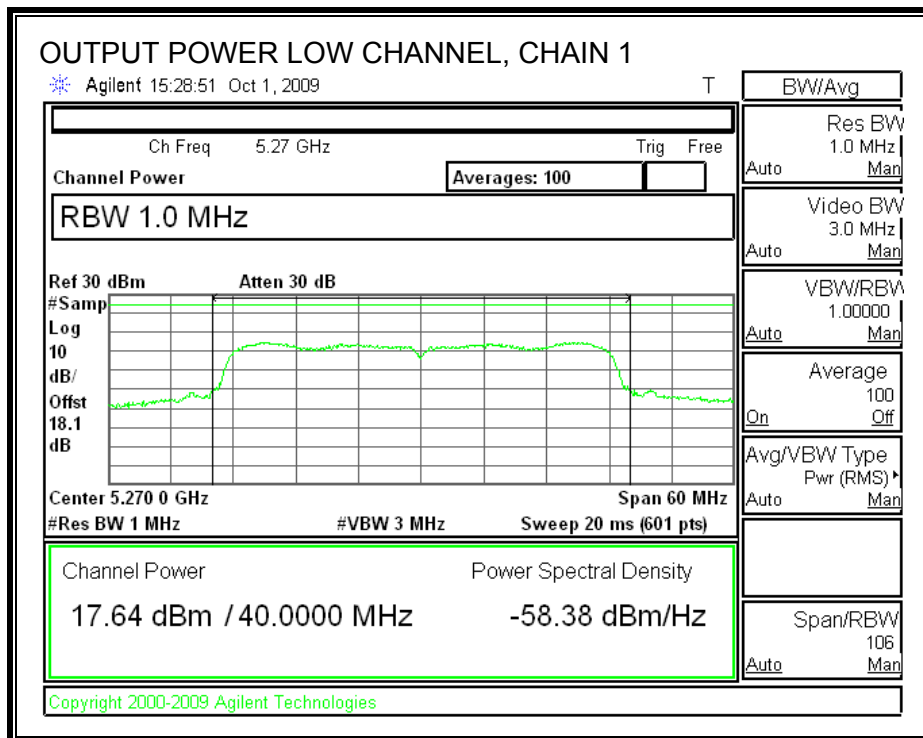
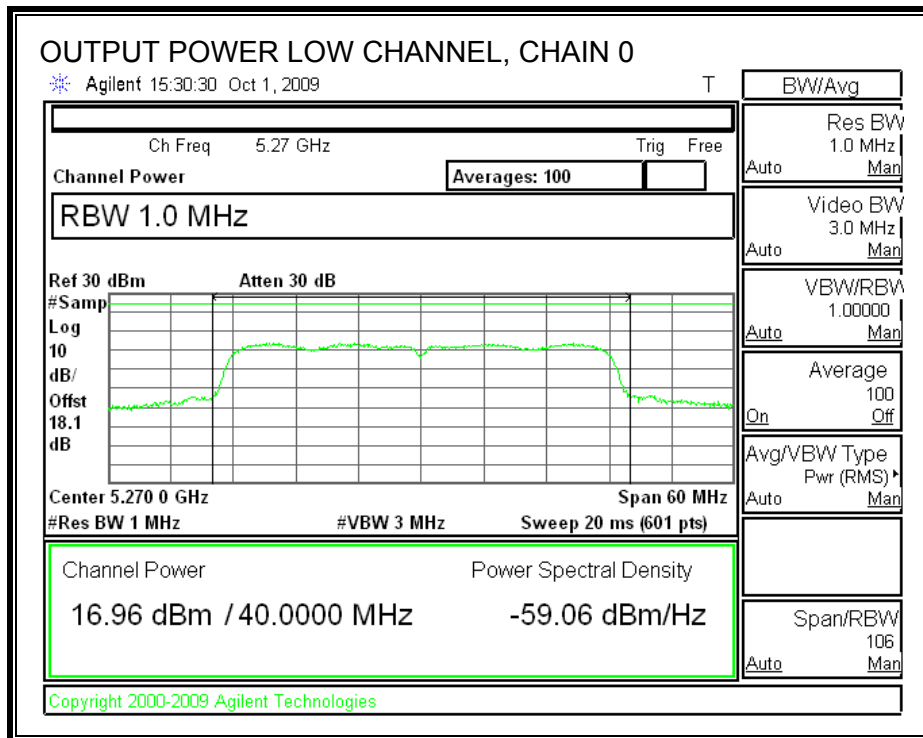

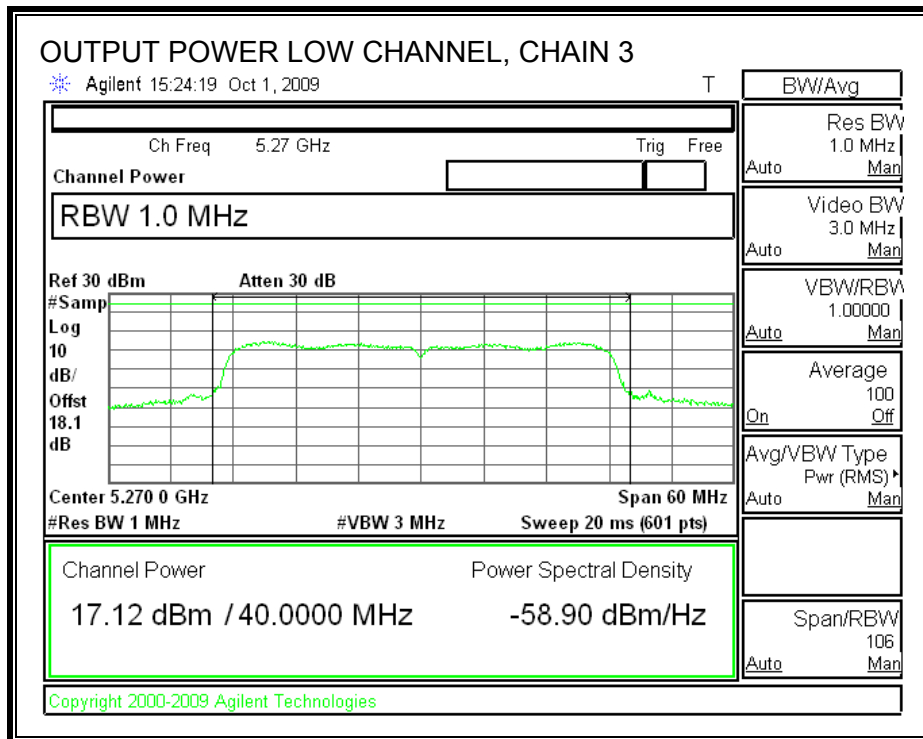
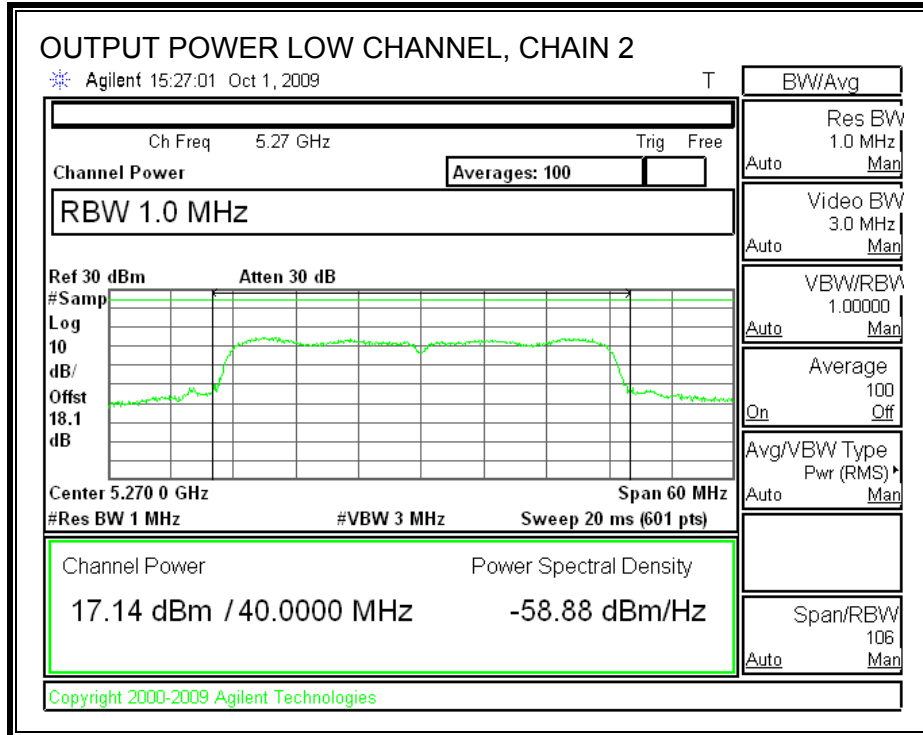

OUTPUT POWER, HIGH CHANNEL

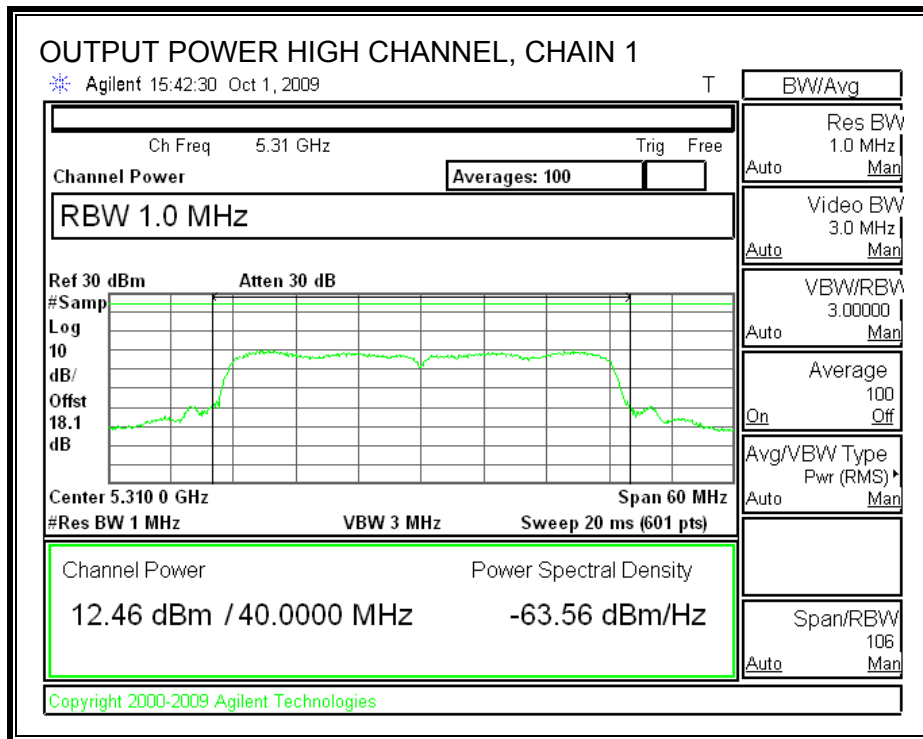
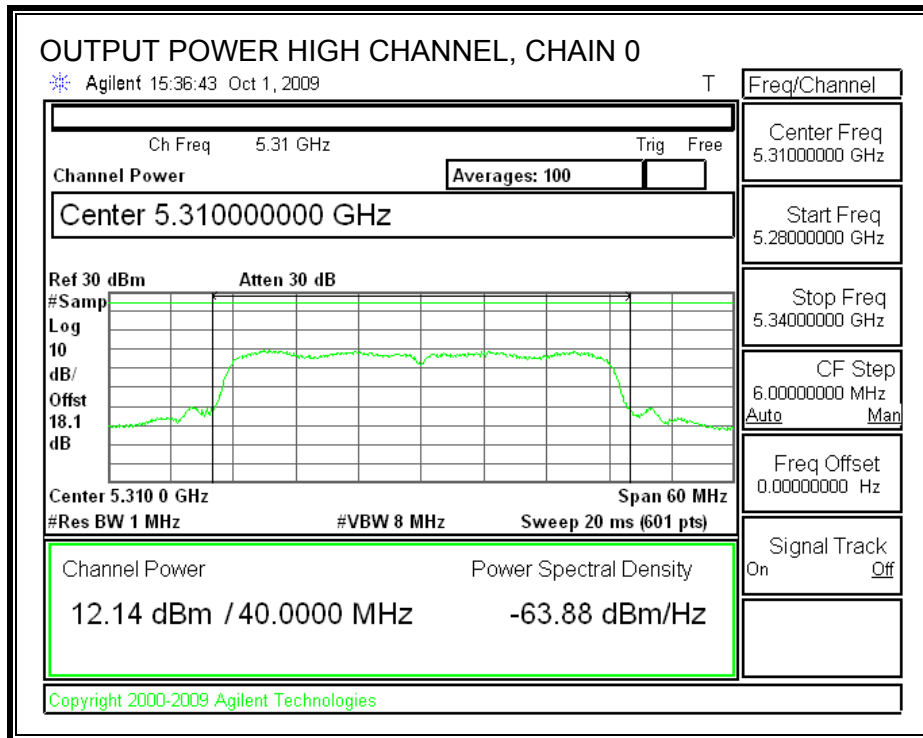

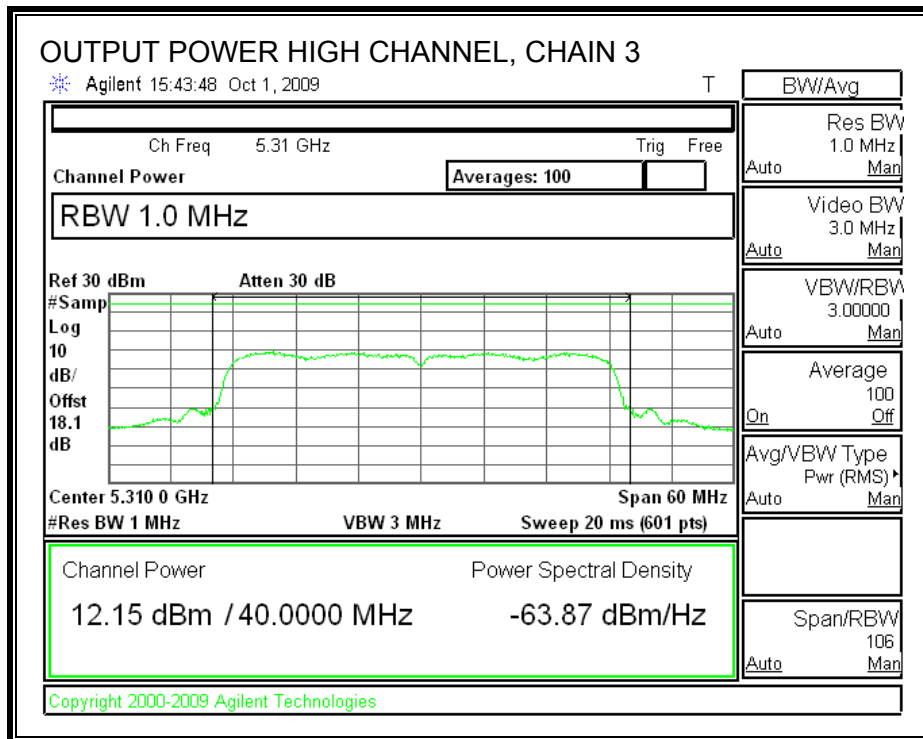
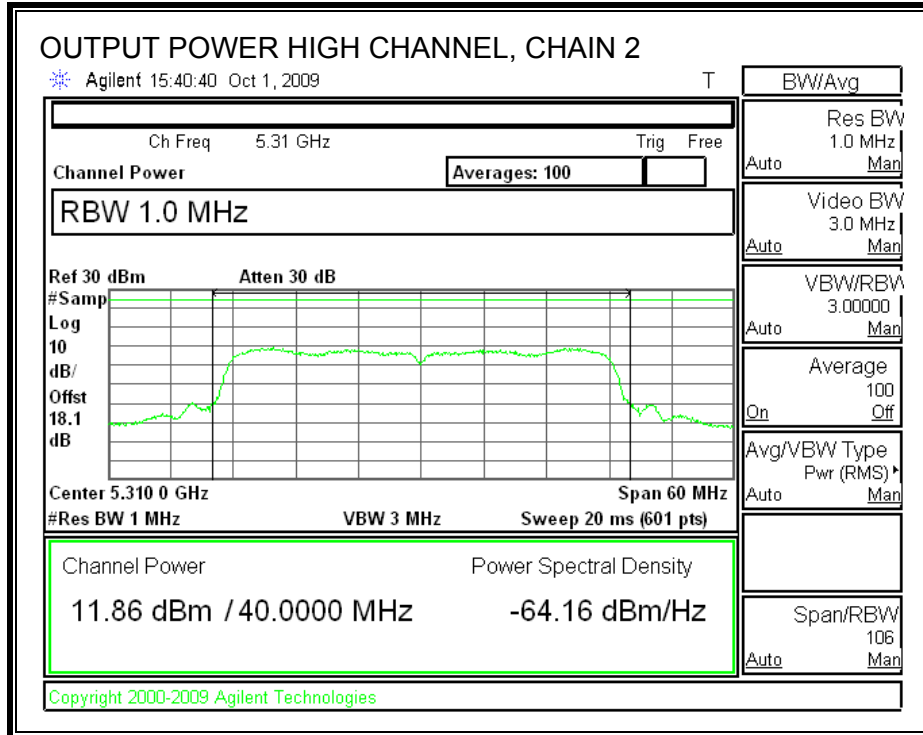

7.6.3. AVERAGE POWER

LIMITS

None; for reporting purposes only.

TEST PROCEDURE

The transmitter output is connected to a power meter.

The cable assembly insertion loss of 11.3 dB (including 10 dB pad and 1.3 dB cable) was entered as an offset in the power meter to allow for direct reading of power.

RESULTS

Channel	Frequency (MHz)	Chain 0 Power (dBm)	Chain 1 Power (dBm)	Chain 2 Power (dBm)	Chain 3 Power (dBm)
Low	5270	16.88	17.59	17.09	17.12
High	5310	12.10	12.38	11.78	12.09

7.6.4. PEAK POWER SPECTRAL DENSITY

LIMITS

FCC §15.407 (a) (2)

IC RSS-210 A9.2 (2)

For the 5.25–5.35 GHz band, the peak power spectral density shall not exceed 11 dBm in any 1 MHz band. If transmitting antennas of directional gain greater than 6 dBi are used, both the peak transmit power and the peak power spectral density shall be reduced by the amount in dB that the directional gain of the antenna exceeds 6 dBi.

The maximum antenna gain is less than 6 dBi, therefore the limit is 11 dBm.

TEST PROCEDURE

The test is performed in accordance with FCC Public Notice: APPENDIX A Guidelines for Assessing Unlicensed National Information Infrastructure (U-NII) Devices – Part 15, Subpart E, August 2002. PPSD method #2 was used.

Preliminary tests on individual chains, and on all chains with a combiner, were performed. The worst-case configuration was with a combiner, therefore final test were performed with all chains feeding a combiner.

RESULTS

Channel	Frequency (MHz)	PSD with Combiner (dBm)	Limit (dBm)	Margin (dB)
Low	5270	8.444	11	-2.56
High	5310	5.444	11	-5.56

POWER SPECTRAL DENSITY

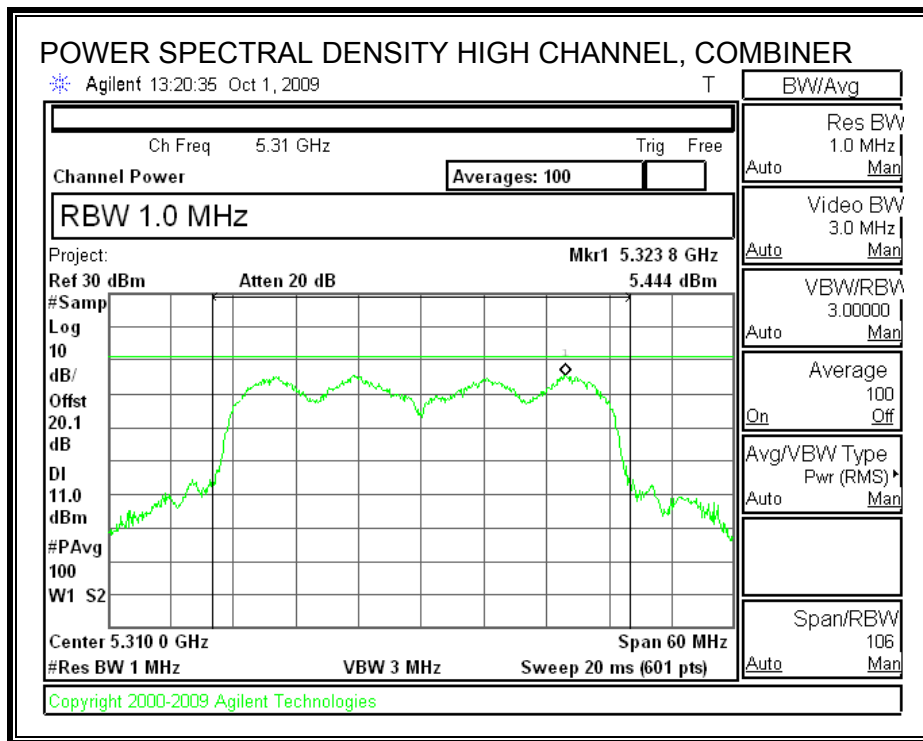
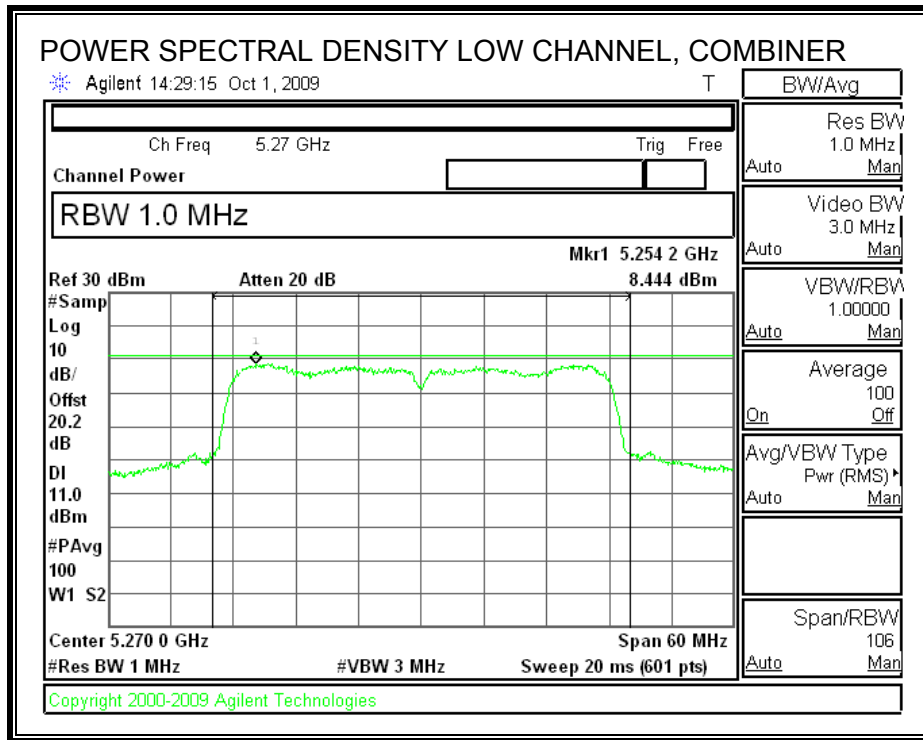

7.6.5. PEAK EXCURSION

LIMITS

FCC §15.407 (a) (6)

The ratio of the peak excursion of the modulation envelope (measured using a peak hold function) to the peak transmit power (measured as specified above) shall not exceed 13 dB across any 1 MHz bandwidth or the emission bandwidth whichever is less.

TEST PROCEDURE

The transmitter outputs are connected to the spectrum analyzer via a combiner.

The test is performed in accordance with FCC Public Notice: APPENDIX A Guidelines for Assessing Unlicensed National Information Infrastructure (U-NII) Devices – Part 15, Subpart E, August 2002.

Since Method # 1 was used for peak power measurements, Method # 1 settings are used for the second PPSD trace.

RESULTS

Channel	Frequency (MHz)	Peak Excursion (dB)	Limit (dB)	Margin (dB)
Low	5270	10.48	13	-2.52
High	5310	9.24	13	-3.76

PEAK EXCURSION

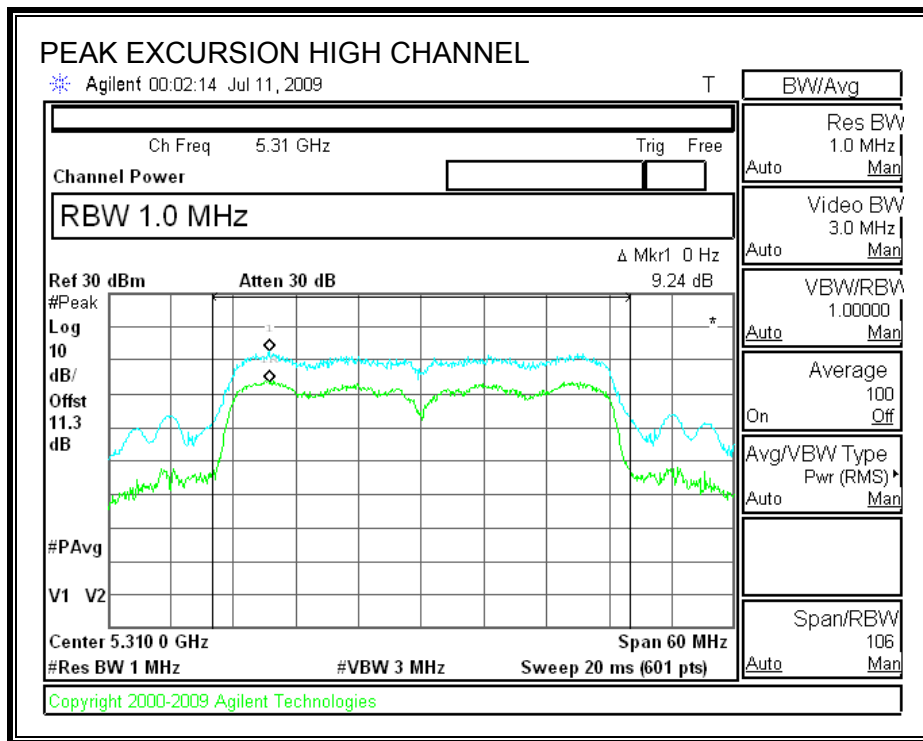
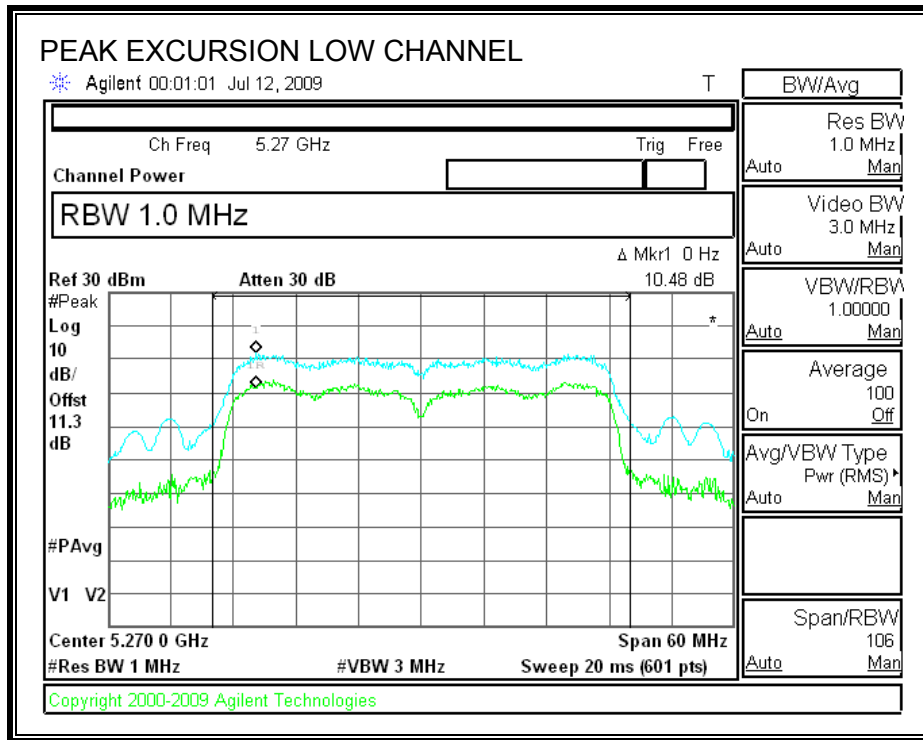

7.6.6. CONDUCTED SPURIOUS EMISSIONS

LIMITS

FCC §15.407 (b) (3)

IC RSS-210 A9.3 (3)

For transmitters operating in the 5.25-5.35 GHz band: all emissions outside of the 5.25-5.35 GHz band shall not exceed an EIRP of -27 dBm / MHz.

Devices operating in the 5.25-5.35 GHz band that generate emissions in the 5.15-5.25 GHz band must meet all applicable technical requirements for operation in the 5.15-5.25 GHz band (including indoor use) or alternatively meet an out-of-band emission EIRP limit of -27 dBm/MHz in the 5.15-5.25 GHz band.

TEST PROCEDURE

Conducted RF measurements of the transmitter output are made to confirm that the EUT antenna port conducted emissions meet the specified limit and to identify any spurious signals that require further investigation or measurements on the radiated emissions site.

The transmitter output is connected to the spectrum analyzer. The resolution bandwidth is set to 1 MHz. The video bandwidth is set to 1 MHz. Peak detection measurements are compared to EIRP limit, adjusted for the maximum antenna gain.

Measurements are made over the 30 MHz to 40 GHz range with the transmitter set to the lowest, middle, and highest channels.

Preliminary tests on individual chains, and on all chains with a combiner, were performed. The worst-case configuration was with a combiner, therefore final test were performed with all chains feeding a combiner.

LOW CHANNEL SPURIOUS EMISSIONS

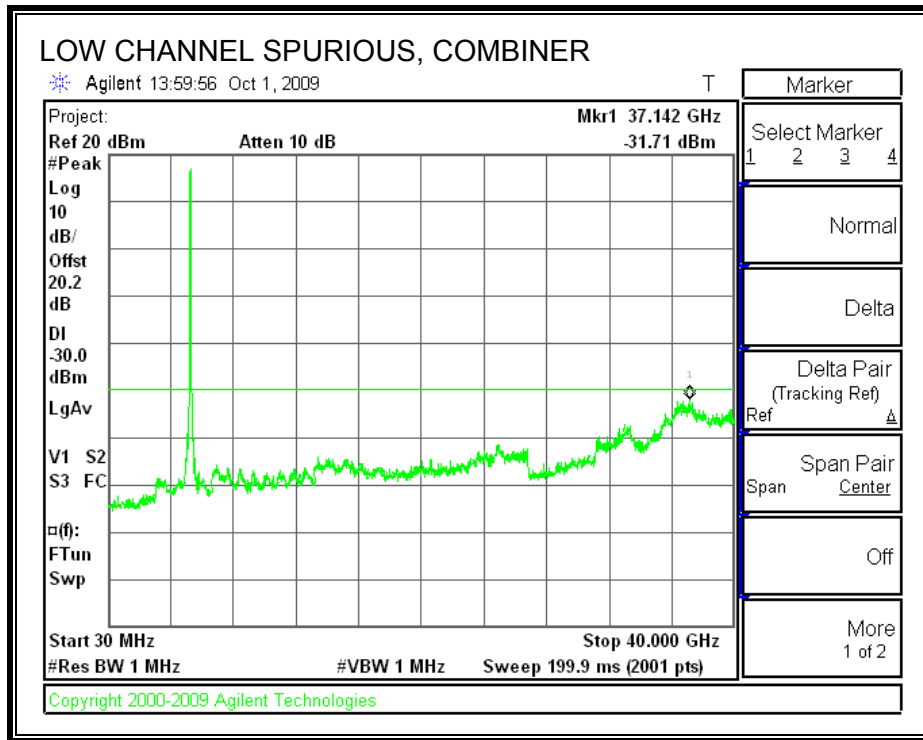

HIGH CHANNEL SPURIOUS EMISSIONS

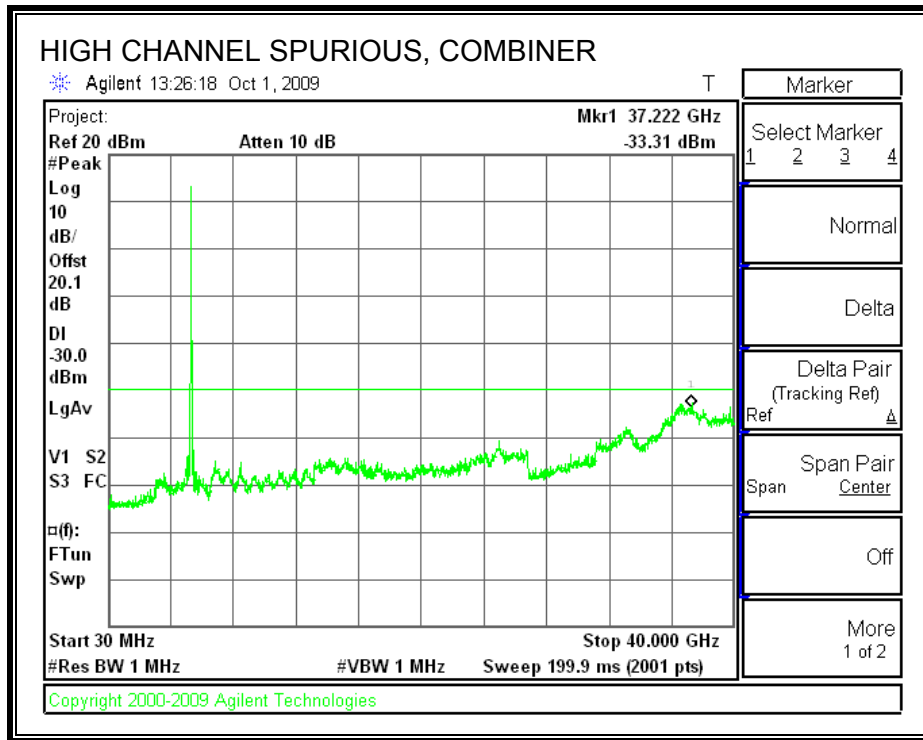

7.7. 5.6 GHz BAND CHANNEL TESTS FOR 802.11a MODE

7.7.1. 26 dB and 99% BANDWIDTH

LIMITS

None; for reporting purposes only.

TEST PROCEDURE

The transmitter outputs are connected to the spectrum analyzer via a combiner. The RBW is set to 1% to 3% of the measured bandwidth. The VBW is set to 3 times the RBW. The sweep time is coupled. The spectrum analyzer internal bandwidth function is utilized.

RESULTS

Channel	Frequency (MHz)	26 dB Bandwidth (MHz)	99% Bandwidth (MHz)
Low	5500	18.9210	16.5224
Middle	5600	18.8560	16.4370
High	5700	19.0480	16.4891

26 dB and 99% BANDWIDTH

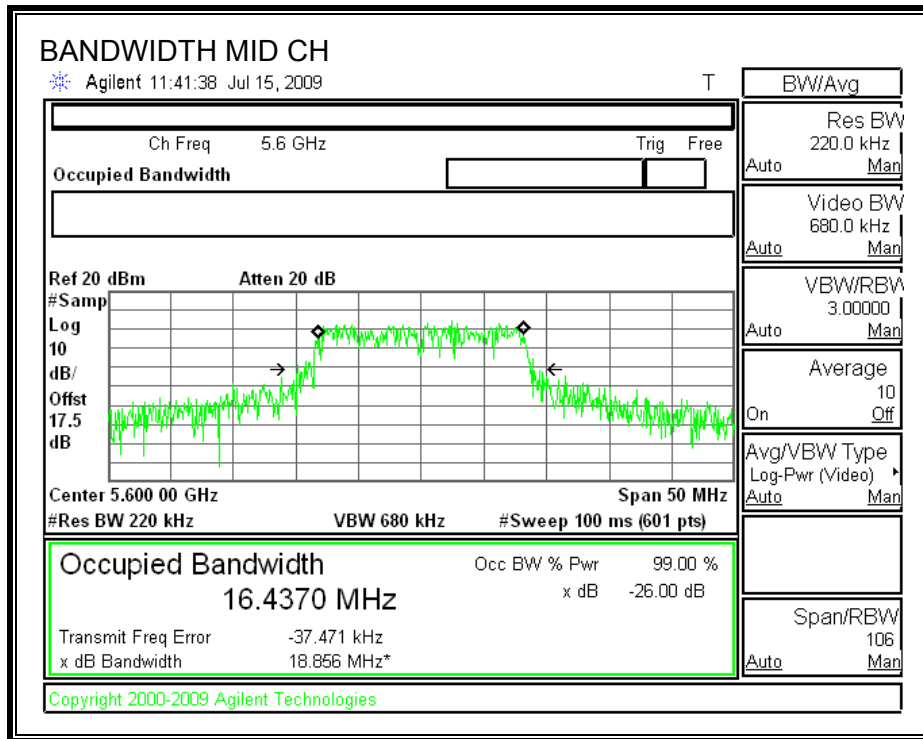
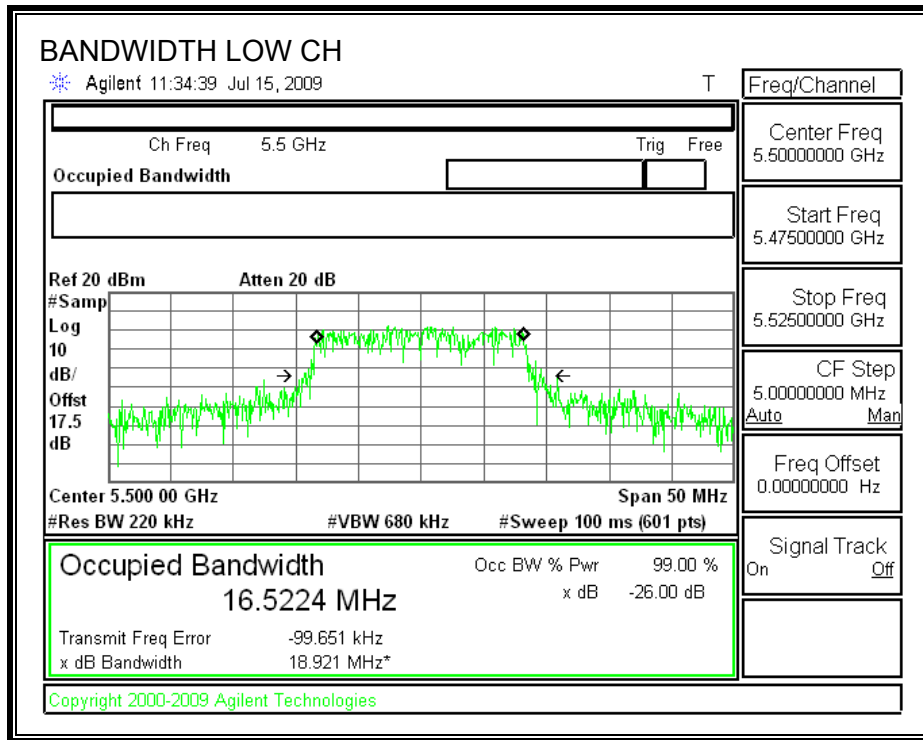

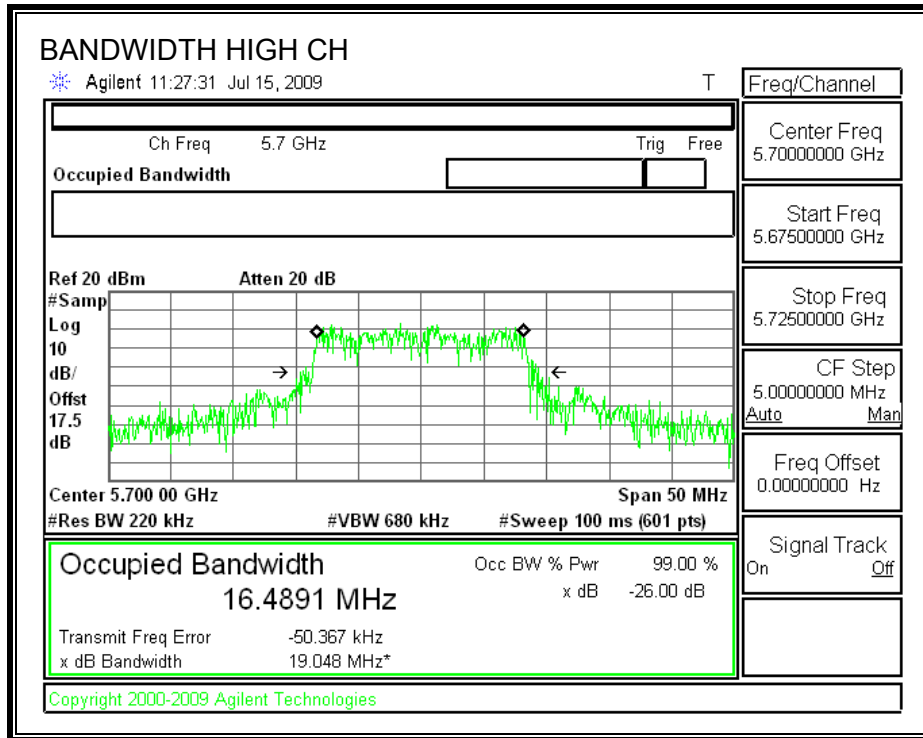

7.7.2. OUTPUT POWER

LIMITS

FCC §15.407 (a) (1)
 IC RSS-210 A9.2 (1)

Antenna gain of Chain 1 = antenna gain of Chain 2.

Antenna Gain (dBi)	10 Log (# Tx Chains) (dB)	Effective Legacy Gain (dBi)
3	3.01	6.01

For the 5.47-5.725 GHz band, the maximum conducted output power over the frequency band of operation shall not exceed the lesser of 250 mW or 11 dBm + 10 log B, where B is the 26-dB emission bandwidth in MHz. If transmitting antennas of directional gain greater than 6 dBi are used, both the peak transmit power and the peak power spectral density shall be reduced by the amount in dB that the directional gain of the antenna exceeds 6 dBi.

TEST PROCEDURE

The test is performed in accordance with FCC Public Notice: APPENDIX A Guidelines for Assessing Unlicensed National Information Infrastructure (U-NII) Devices – Part 15, Subpart E, August 2002.

The transmitter output operates continuously therefore Method # 1 is used.

RESULTS

Limit

Channel	Frequency (MHz)	Fixed Limit (dBm)	B (MHz)	11 + 10 Log B Limit (dBm)	Effective Ant Gain (dBi)	Limit (dBm)
Low	5500	24	18.9210	23.77	6.01	23.76
Mid	5600	24	18.8560	23.75	6.01	23.74
High	5700	24	19.0480	23.80	6.01	23.79

Individual Chain Results

Channel	Frequency (MHz)	Chain 0 Power (dBm)	Chain 1 Power (dBm)	Total Power (dBm)	Limit (dBm)	Margin (dB)
Low	5500	16.31	18.85	20.77	23.76	-2.99
Mid	5600	15.84	16.35	19.11	23.74	-4.63
High	5700	14.47	13.84	17.18	23.79	-6.61

OUTPUT POWER, LOW CHANNEL

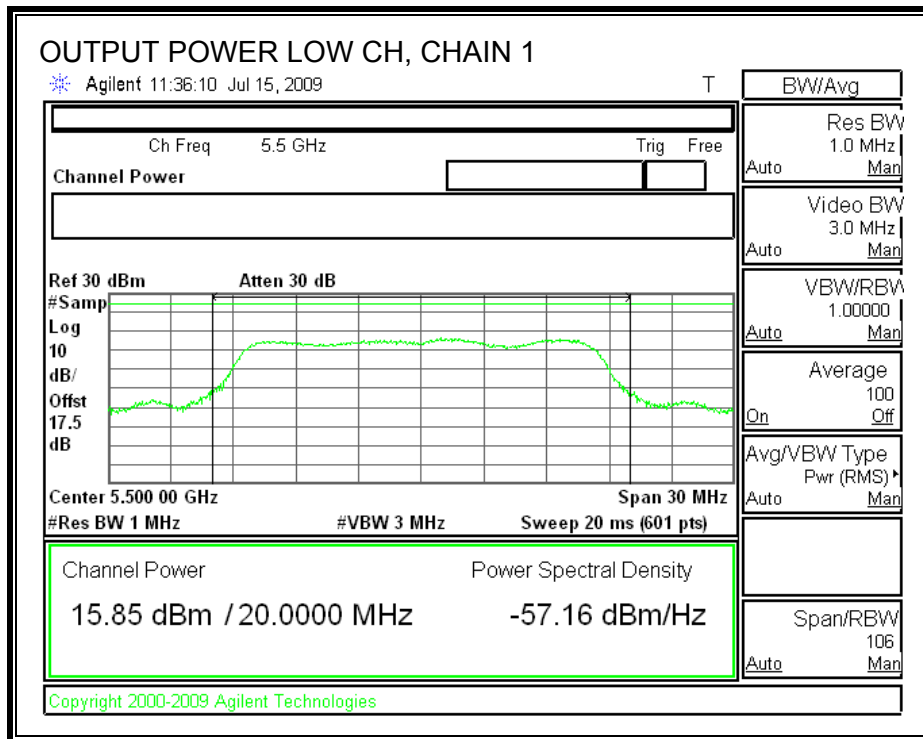
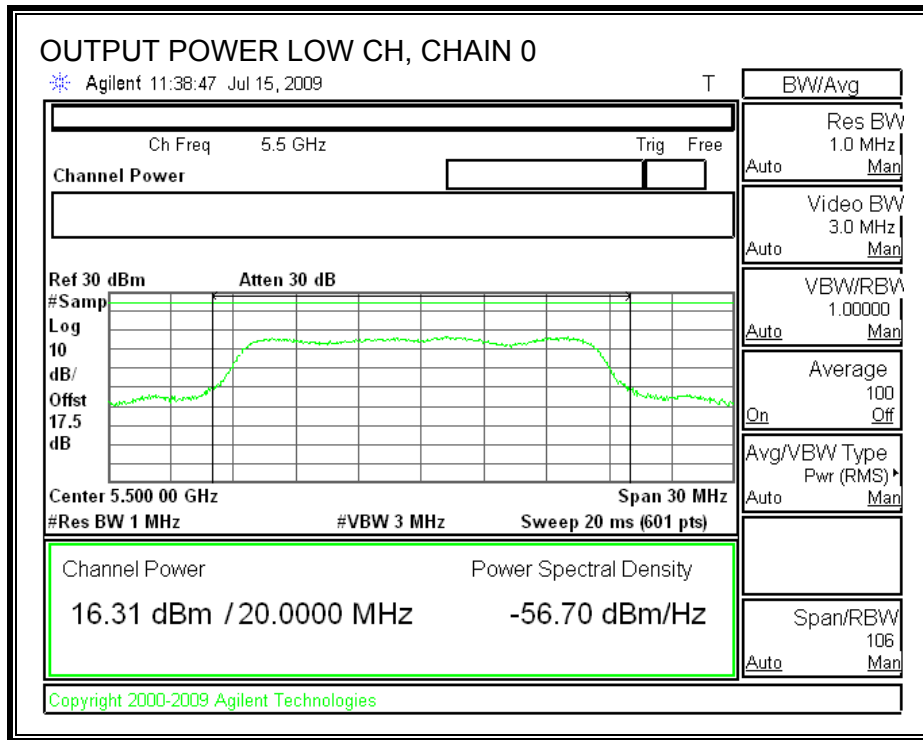

OUTPUT POWER, MID CHANNEL

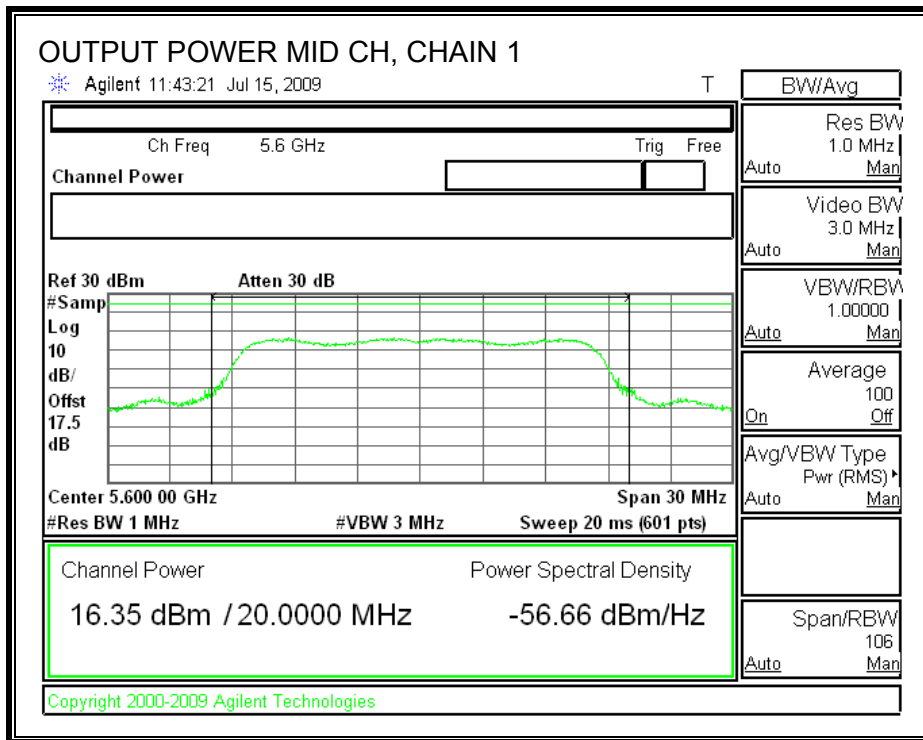
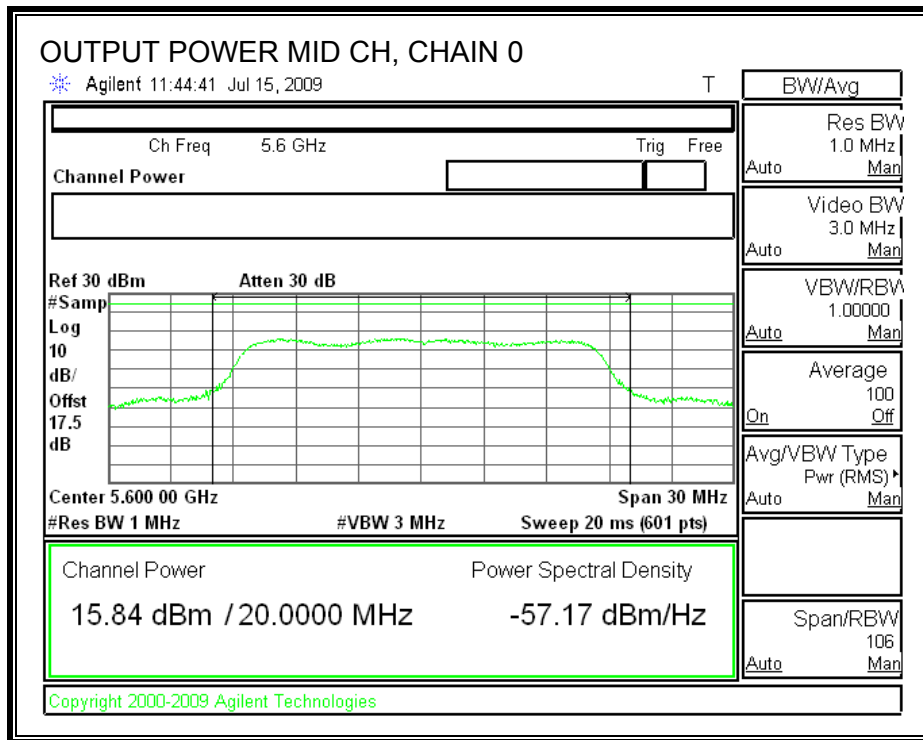

OUTPUT POWER, HIGH CHANNEL

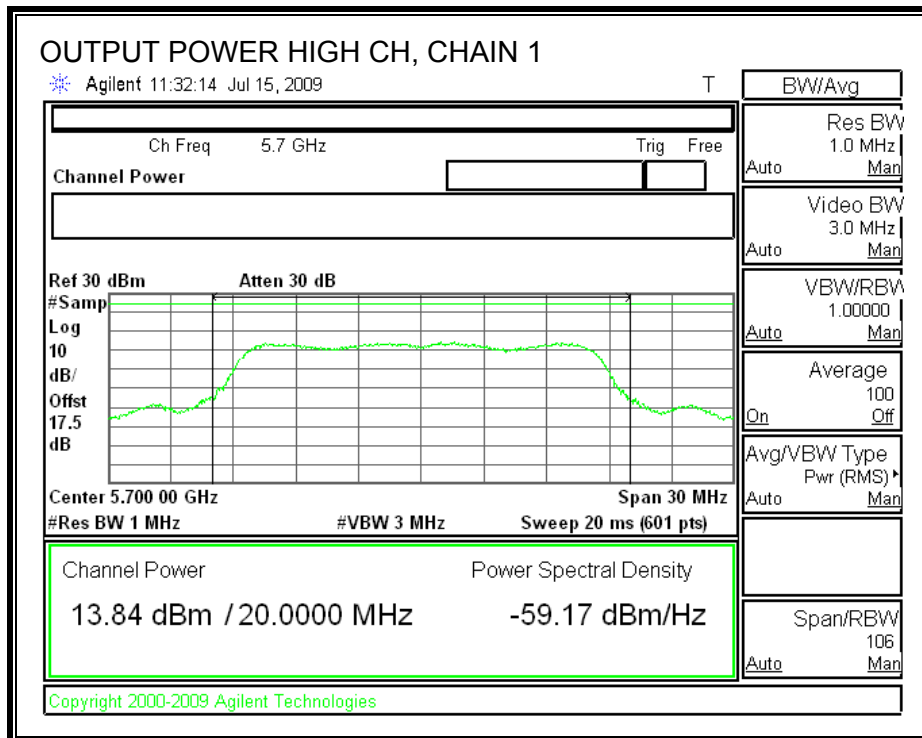
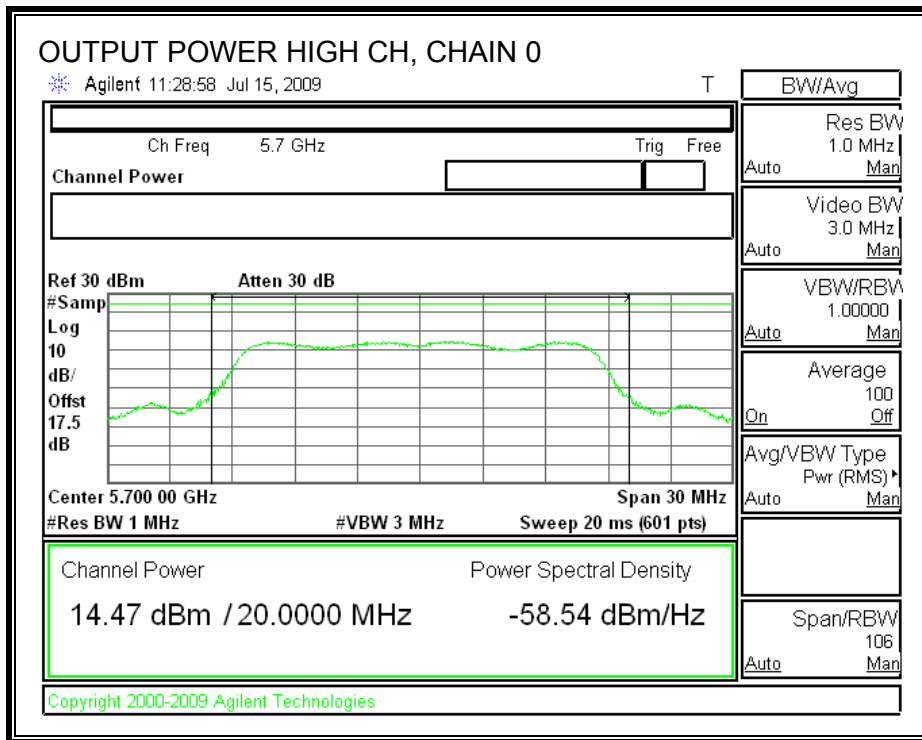

7.7.3. AVERAGE POWER

LIMITS

None; for reporting purposes only.

TEST PROCEDURE

The transmitter output is connected to a power meter.

RESULTS

The cable assembly insertion loss of 11.3 dB (including 10 dB pad and 1.3 dB cable) was entered as an offset in the power meter to allow for direct reading of power.

Channel	Frequency (MHz)	Chain 0 Power (dBm)	Chain 1 Power (dBm)	Total Power (dBm)
Low	5500	15.83	16.25	19.06
Middle	5600	16.06	16.30	19.19
High	5700	14.49	13.85	17.19

7.7.4. PEAK POWER SPECTRAL DENSITY

LIMITS

FCC §15.407 (a) (1)

IC RSS-210 A9.2 (1)

Use this table if antenna gain for Chain 1 = antenna gain for Chain 2

Antenna Gain (dBi)	10 Log (# Tx Chains) (dB)	Effective Legacy Gain (dBi)
3	3.01	6.01

For the 5.47-5.725 GHz band, the peak power spectral density shall not exceed 11 dBm in any 1 MHz band. If transmitting antennas of directional gain greater than 6 dBi are used, both the peak transmit power and the peak power spectral density shall be reduced by the amount in dB that the directional gain of the antenna exceeds 6 dBi.

The maximum effective antenna gain is 6.01 dBi, therefore the limit is 10.99 dBm.

TEST PROCEDURE

The test is performed in accordance with FCC Public Notice: APPENDIX A Guidelines for Assessing Unlicensed National Information Infrastructure (U-NII) Devices – Part 15, Subpart E, August 2002. PPSD method #2 was used.

RESULTS

Channel	Frequency (MHz)	PPSD With Combiner (dBm)	Limit (dBm)	Margin (dB)
Low	5500	10.92	10.99	-0.07
Middle	5600	10.66	10.99	-0.33
High	5700	8.00	10.99	-2.99

POWER SPECTRAL DENSITY WITH COMBINER

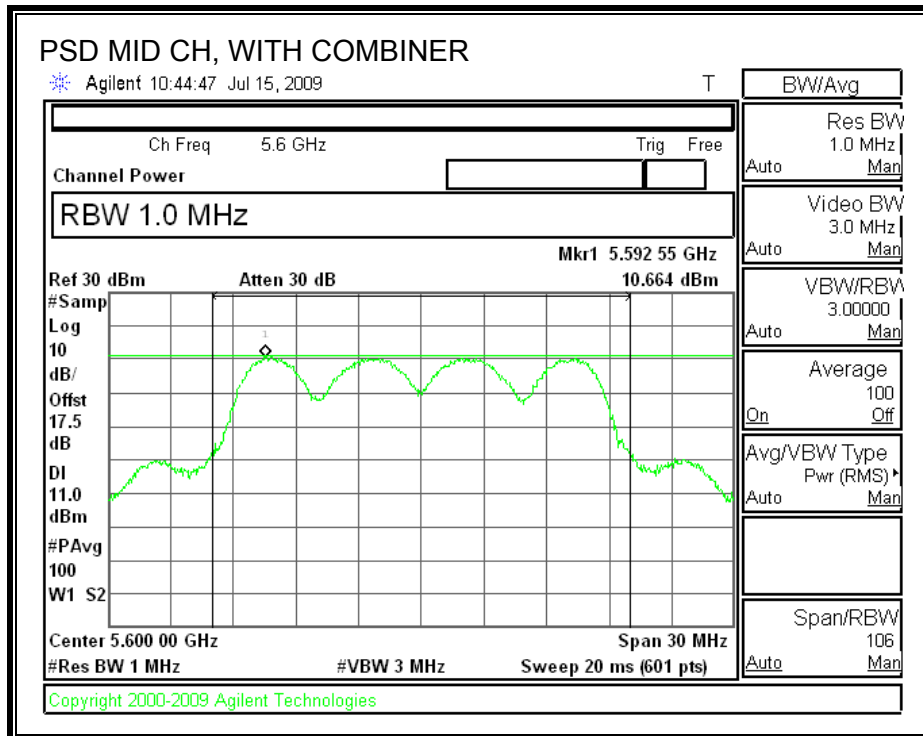
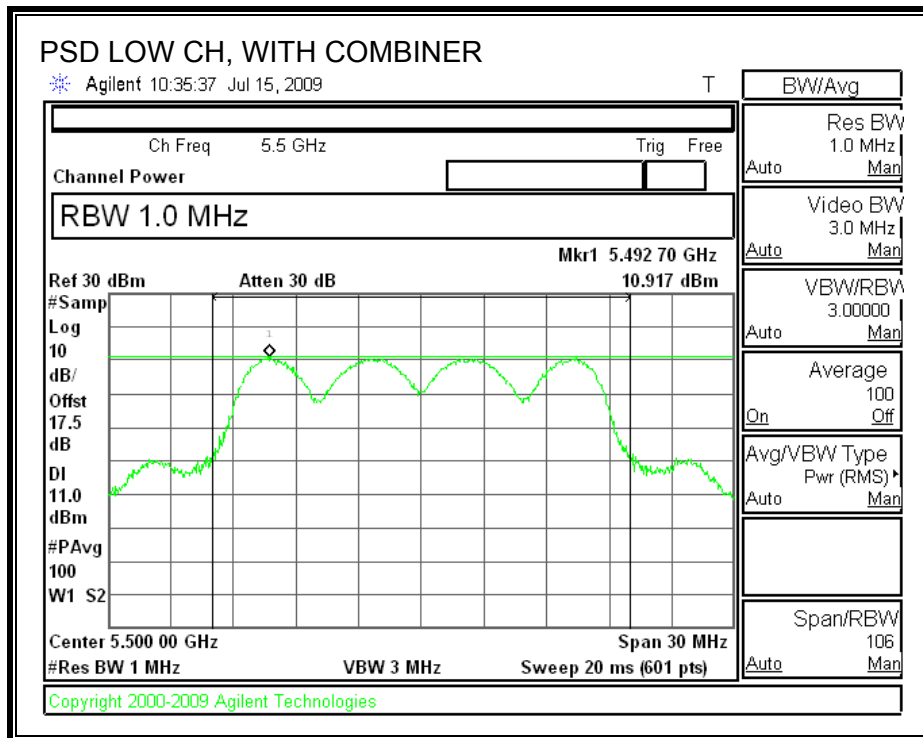

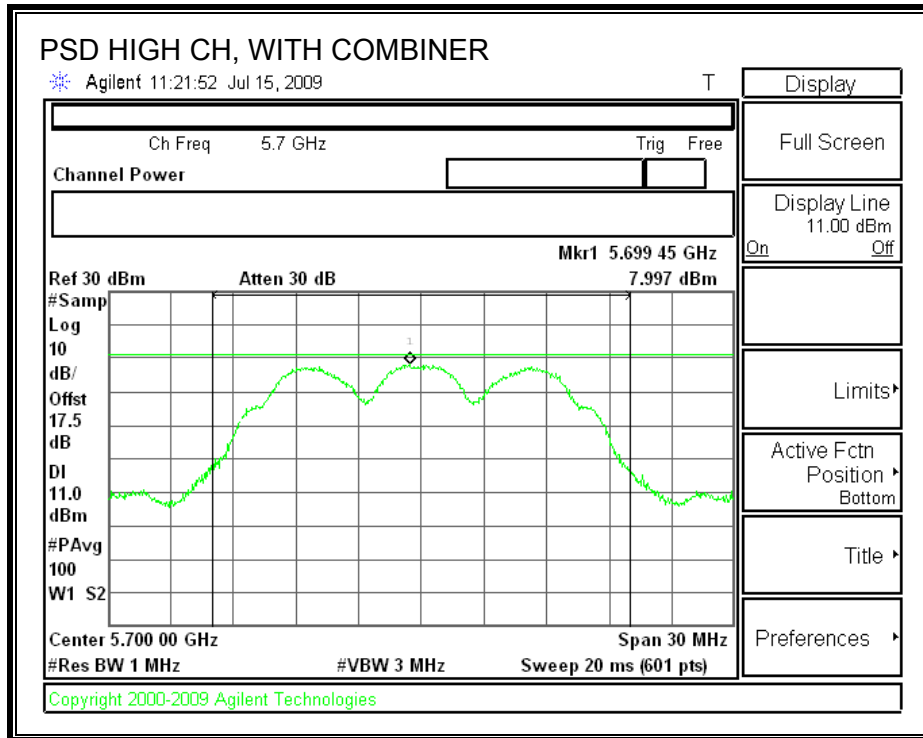

7.7.5. PEAK EXCURSION

LIMITS

FCC §15.407 (a) (6)

The ratio of the peak excursion of the modulation envelope (measured using a peak hold function) to the peak transmit power (measured as specified above) shall not exceed 13 dB across any 1 MHz bandwidth or the emission bandwidth whichever is less.

TEST PROCEDURE

The transmitter outputs are connected to the spectrum analyzer via a combiner.

The test is performed in accordance with FCC Public Notice: APPENDIX A Guidelines for Assessing Unlicensed National Information Infrastructure (U-NII) Devices – Part 15, Subpart E, August 2002.

Since Method # 1 was used for peak power measurements, Method # 1 settings are used for the second PPSD trace.

RESULTS

Channel	Frequency (MHz)	Peak Excursion (dB)	Limit (dB)	Margin (dB)
Low	5500	8.29	13	-4.71
Middle	5600	10.11	13	-2.89
High	5700	7.97	13	-5.03

PEAK EXCURSION

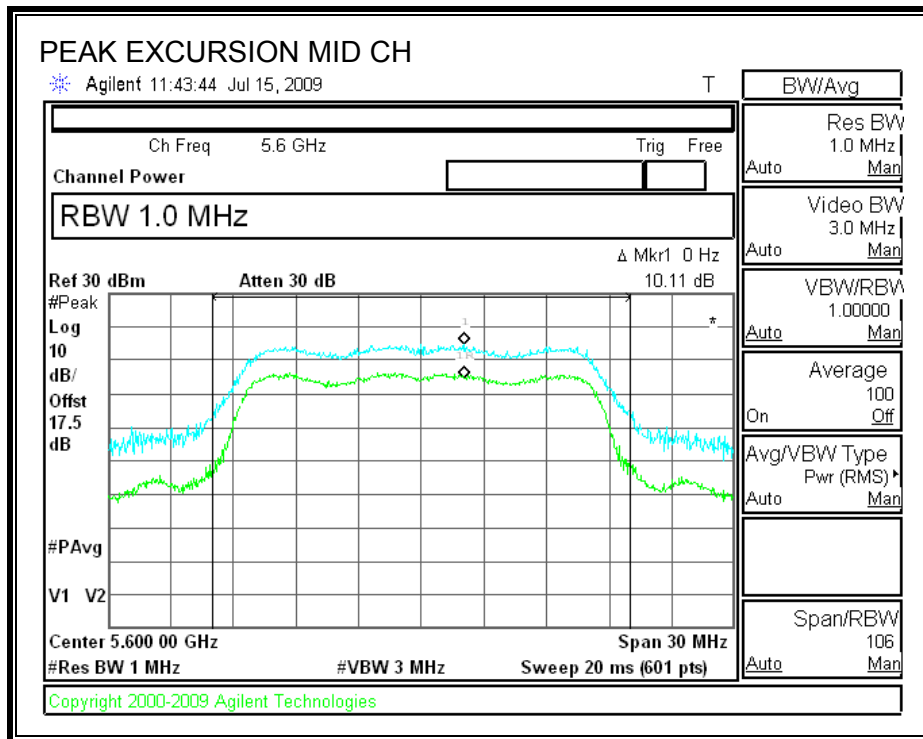
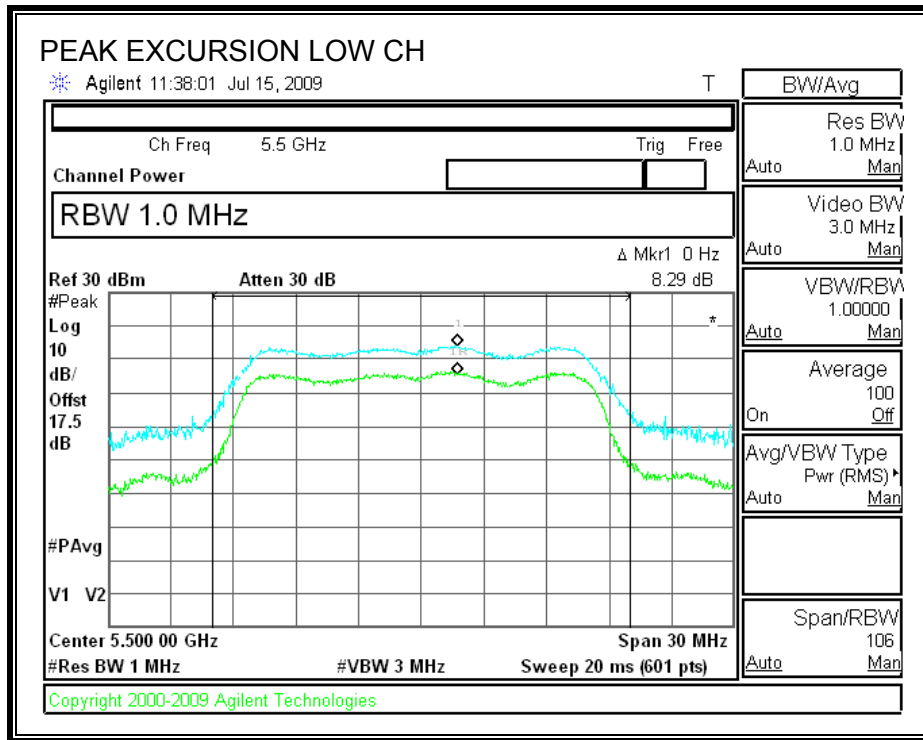

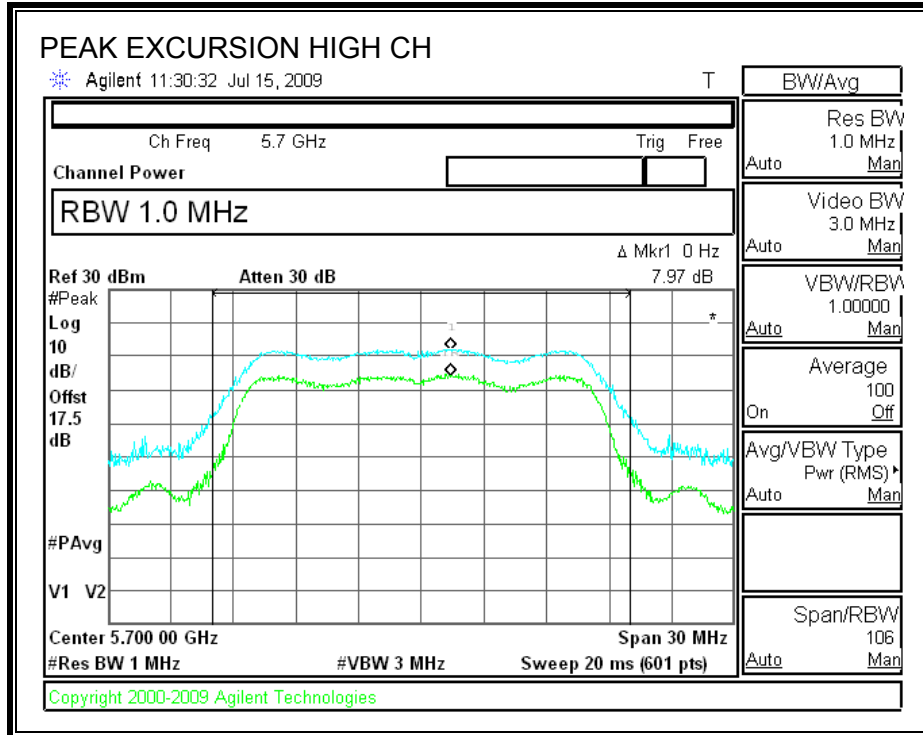

7.7.6. CONDUCTED SPURIOUS EMISSIONS

LIMITS

FCC §15.407 (b) (1)

IC RSS-210 A9.3 (1)

For transmitters operating in the 5.47-5.725 GHz band: all emissions outside of the 5.47-5.725 GHz band shall not exceed an EIRP of -27 dBm / MHz.

TEST PROCEDURE

Conducted RF measurements of the transmitter output are made to confirm that the EUT antenna port conducted emissions meet the specified limit and to identify any spurious signals that require further investigation or measurements on the radiated emissions site.

The transmitter output is connected to the spectrum analyzer. The resolution bandwidth is set to 1 MHz. The video bandwidth is set to 1 MHz. Peak detection measurements are compared to EIRP limit, adjusted for the maximum antenna gain.

Measurements are made over the 30 MHz to 40 GHz range with the transmitter set to the lowest, middle, and highest channels.

SPURIOUS EMISSIONS WITH COMBINER

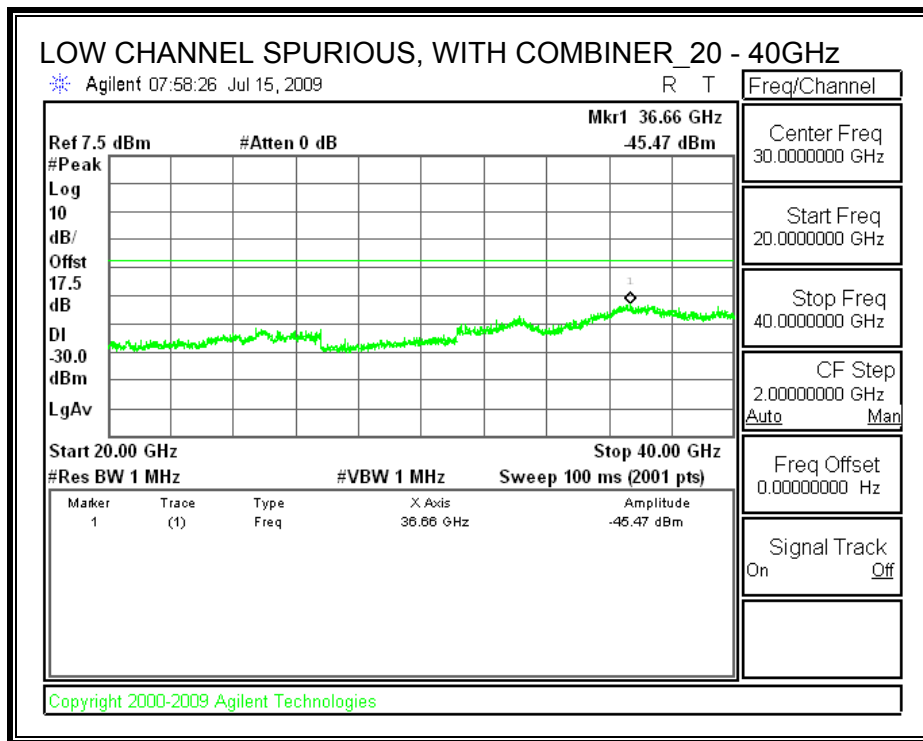
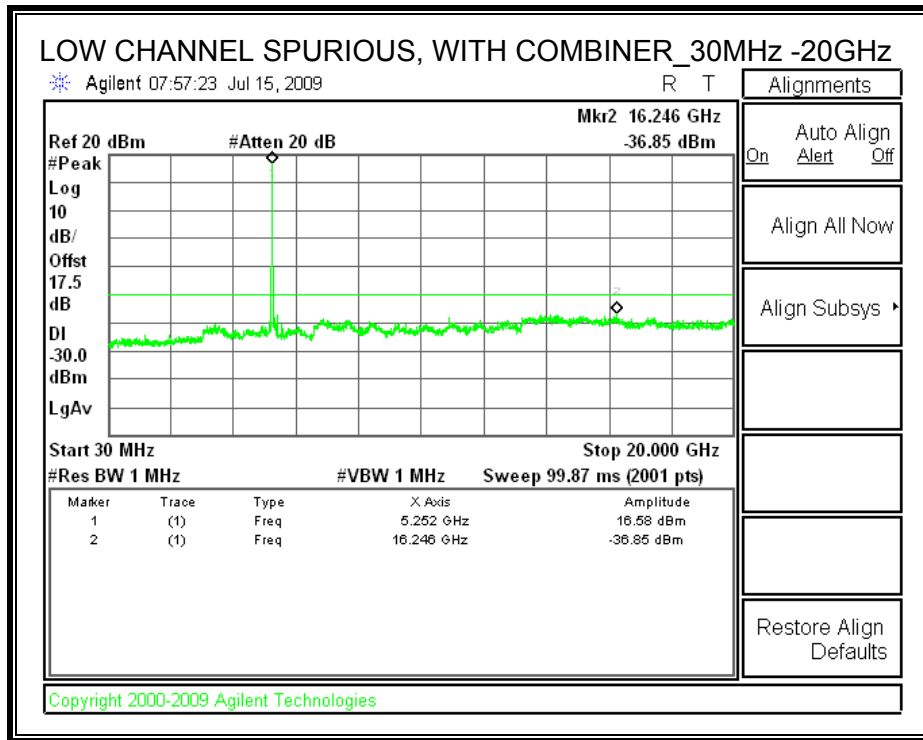

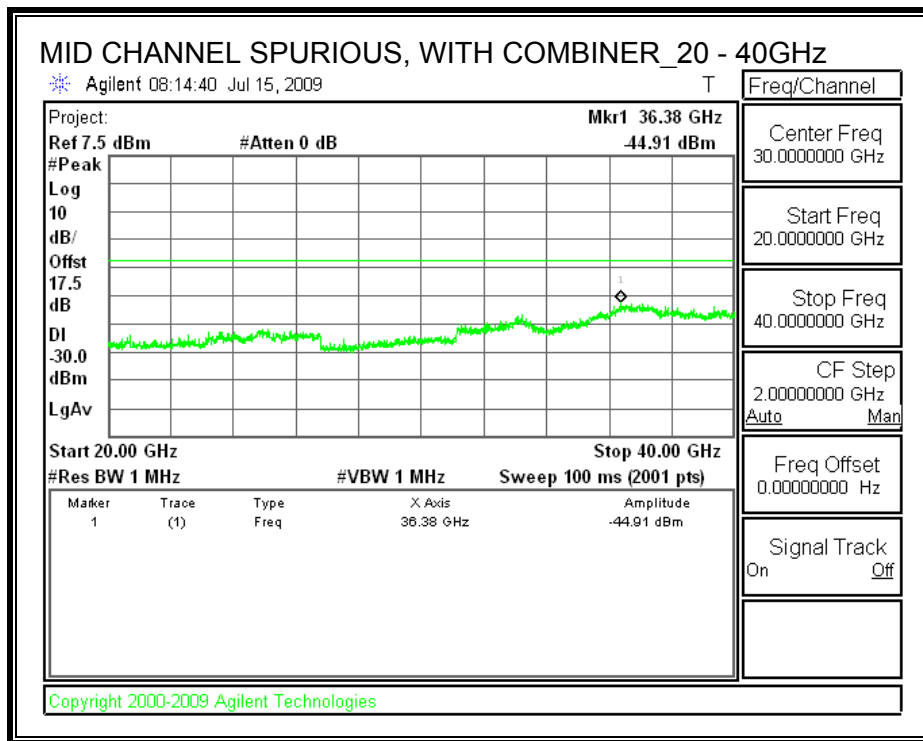
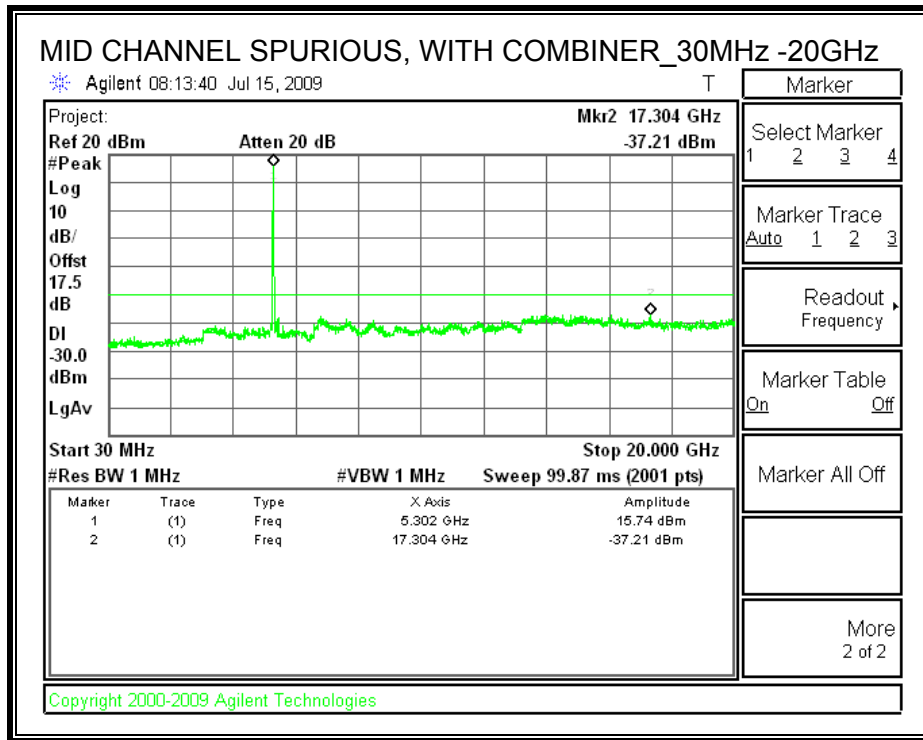

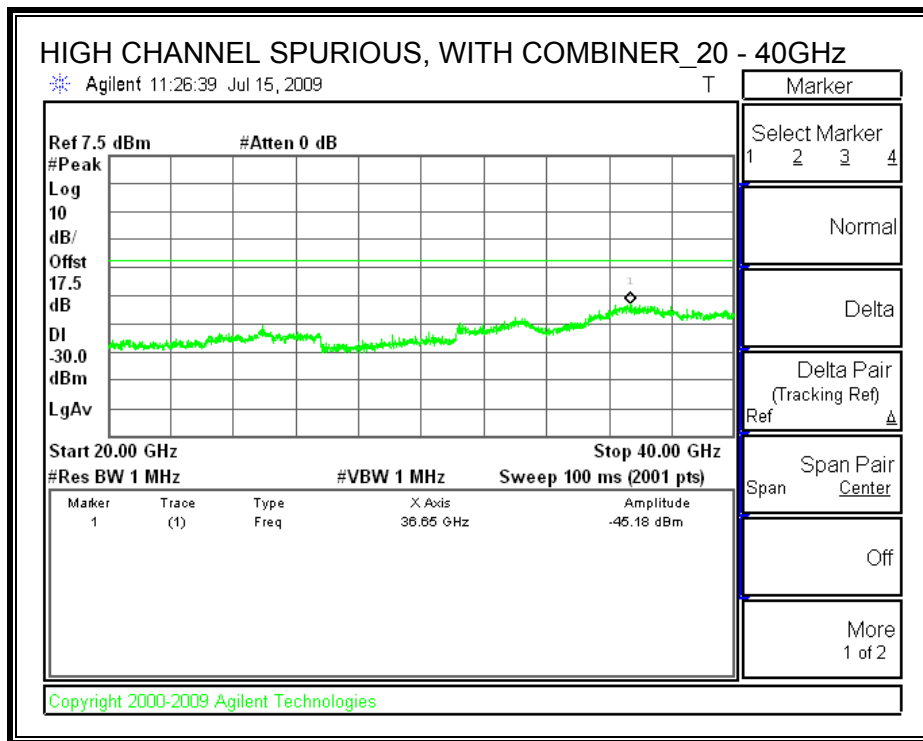
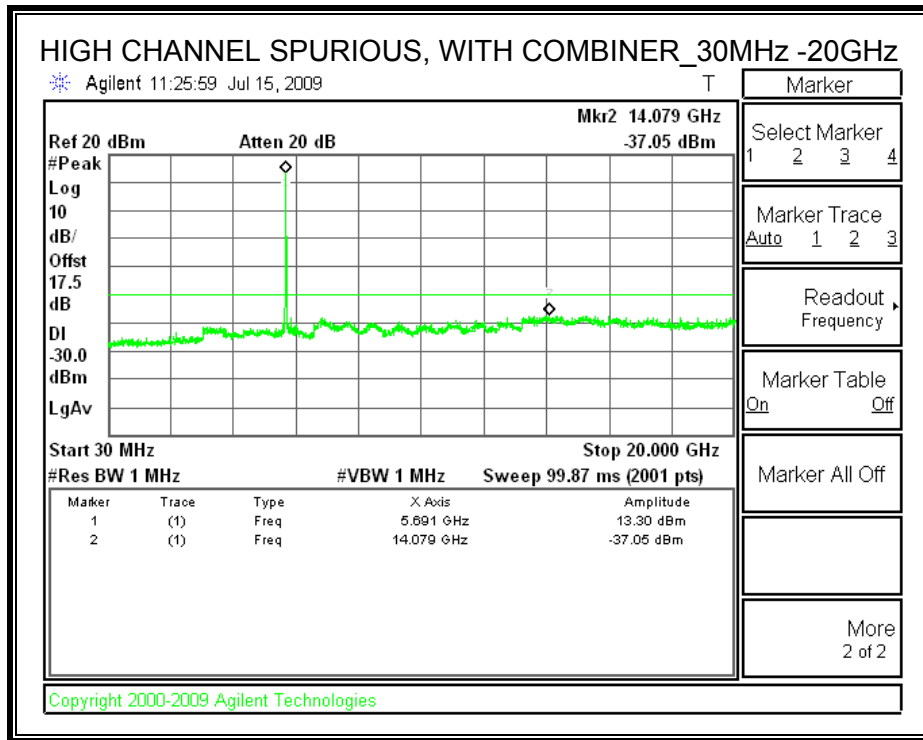

7.8. 5.6 GHz BAND CHANNEL TESTS FOR 802.11n HT20 MODE

7.8.1. 99% & 26 dB BANDWIDTH

LIMITS

None; for reporting purposes only.

TEST PROCEDURE

The transmitter output is connected to the spectrum analyzer. The RBW is set to 1% to 3% of the bandwidth. The VBW is set to 3 times the RBW. The sweep time is coupled. The spectrum analyzer internal bandwidth measurement function is utilized.

RESULTS

Channel	Frequency (MHz)	99% OBW (MHz)	26 dB BW (MHz)
Low	5500	17.6399	19.702
Middle	5600	17.6139	18.601
High	5700	17.5162	18.450

99% & 26 dB BANDWIDTH

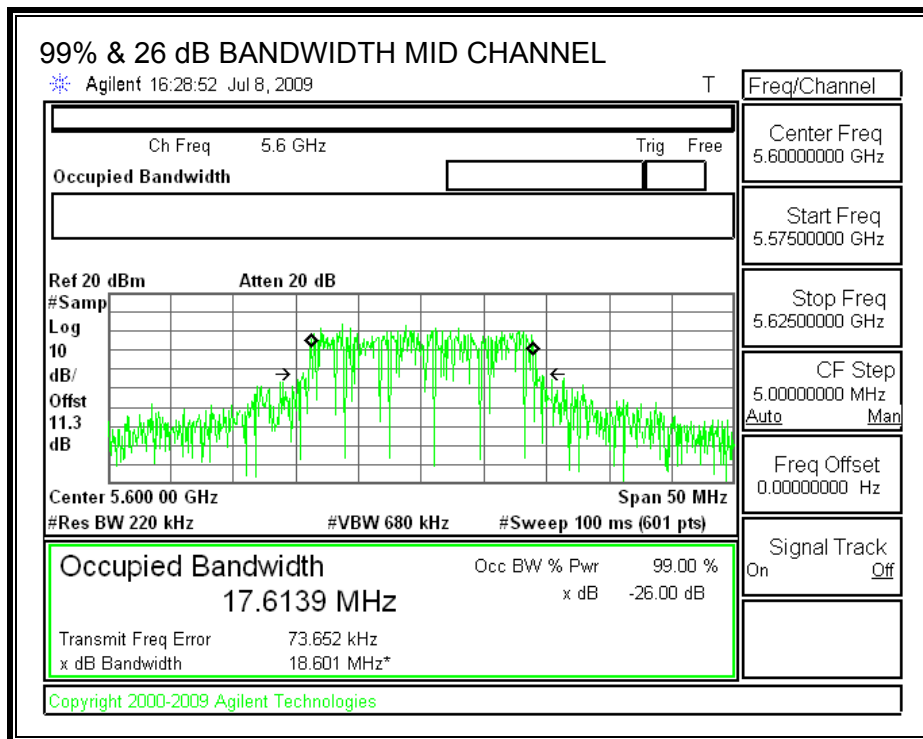
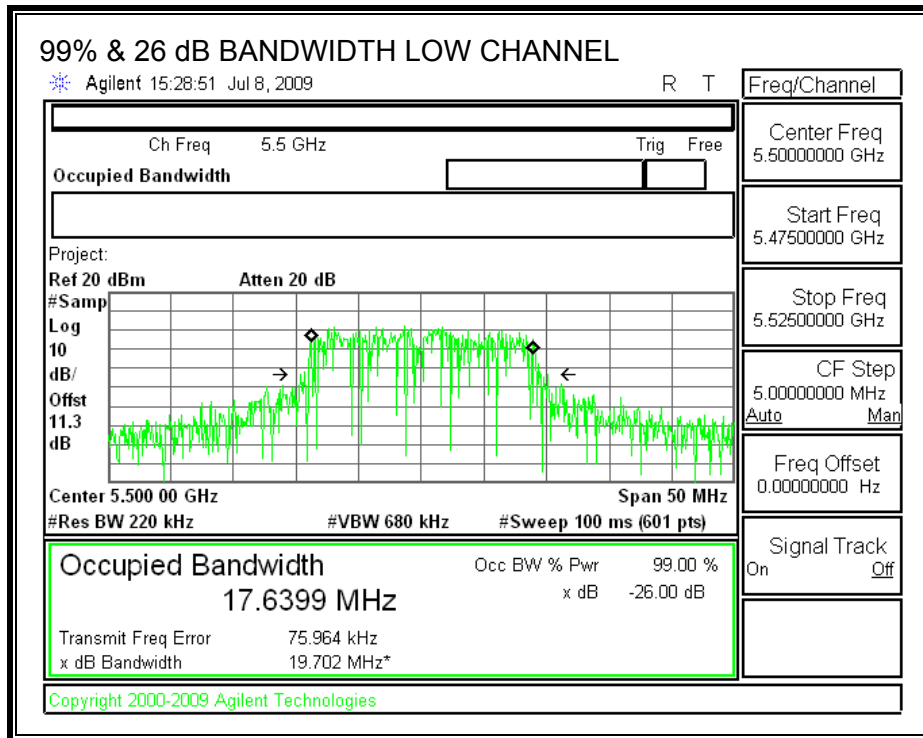

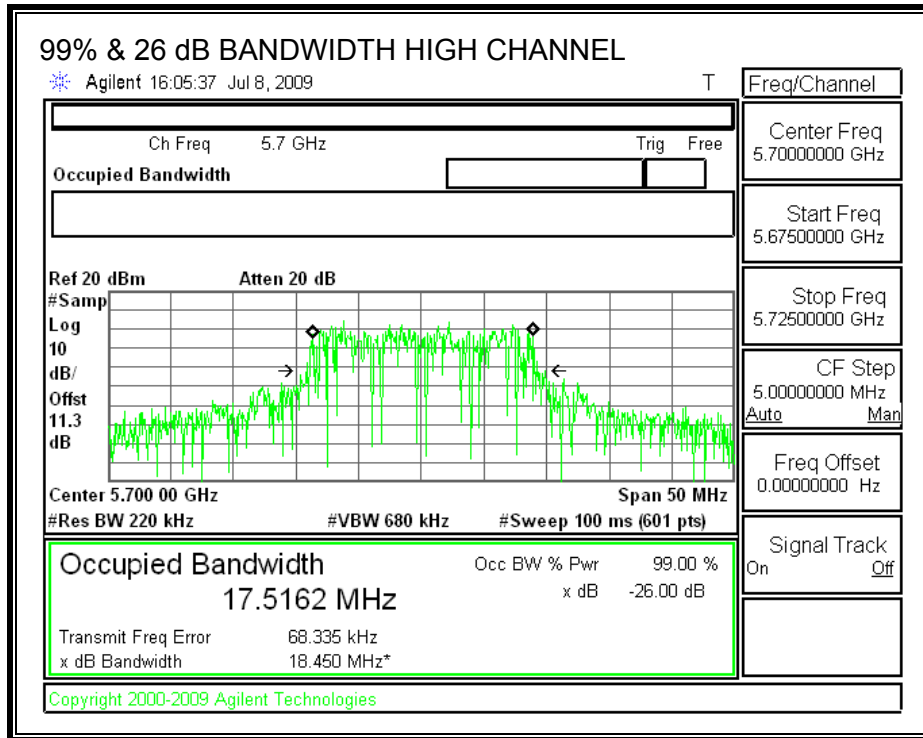

7.8.2. OUTPUT POWER

LIMITS

FCC §15.407 (a) (2)
 IC RSS-210 A9.2 (2)

For the 5.47-5.725 GHz band, the maximum conducted output power over the frequency band of operation shall not exceed the lesser of 250 mW or 11 dBm + 10 log B, where B is the 26-dB emission bandwidth in MHz. If transmitting antennas of directional gain greater than 6 dBi are used, both the peak transmit power and the peak power spectral density shall be reduced by the amount in dB that the directional gain of the antenna exceeds 6 dBi.

TEST PROCEDURE

The test is performed in accordance with FCC Public Notice: APPENDIX A Guidelines for Assessing Unlicensed National Information Infrastructure (U-NII) Devices – Part 15, Subpart E, August 2002.

The transmitter output operates continuously therefore Method # 1 is used.

RESULTS

Limit

Channel	Freq (MHz)	Fixed Limit (dBm)	B (MHz)	11 + 10 Log B Limit (dBm)	Antenna Gain (dBi)	Limit (dBm)
Low	5500	24	19.702	23.95	3	23.95
Mid	5600	24	18.601	23.70	3	23.70
High	5700	24	18.450	23.66	3	23.66

Individual Chain Results

Channel	Freq (MHz)	Chain 0 Power (dBm)	Chain 1 Power (dBm)	Chain 2 Power (dBm)	Chain 3 Power (dBm)	Total Power (dBm)	Limit (dBm)	Margin (dB)
Low	5500	14.13	14.00	14.21	14.23	20.16	23.95	-3.78
Mid	5600	14.06	14.10	14.29	14.10	20.16	23.70	-3.54
High	5700	14.22	14.24	14.30	14.13	20.24	23.66	-3.42

OUTPUT POWER, LOW CHANNEL

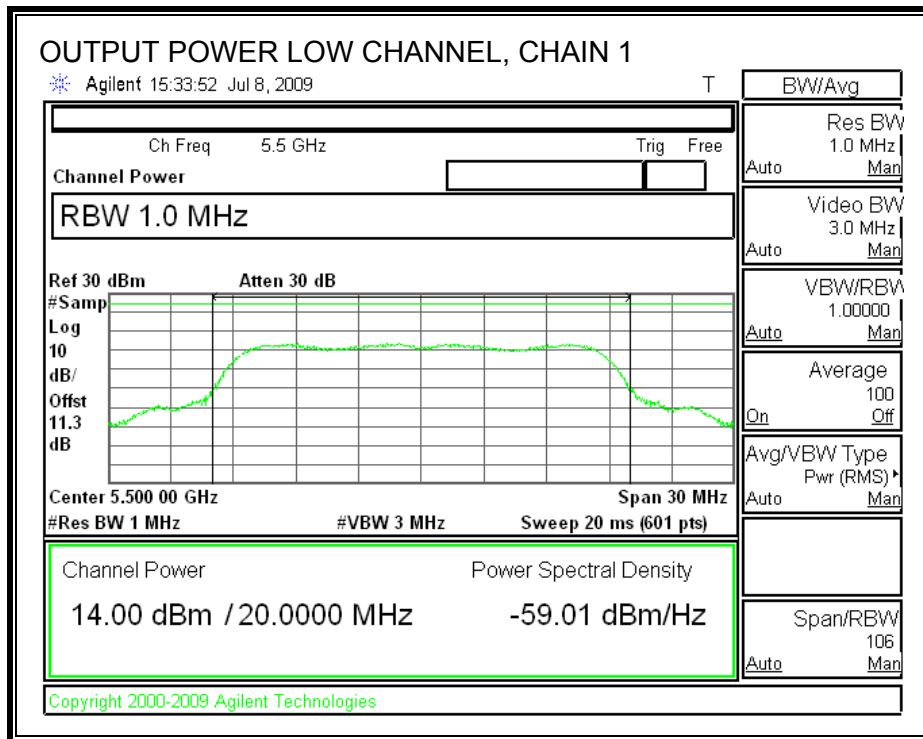
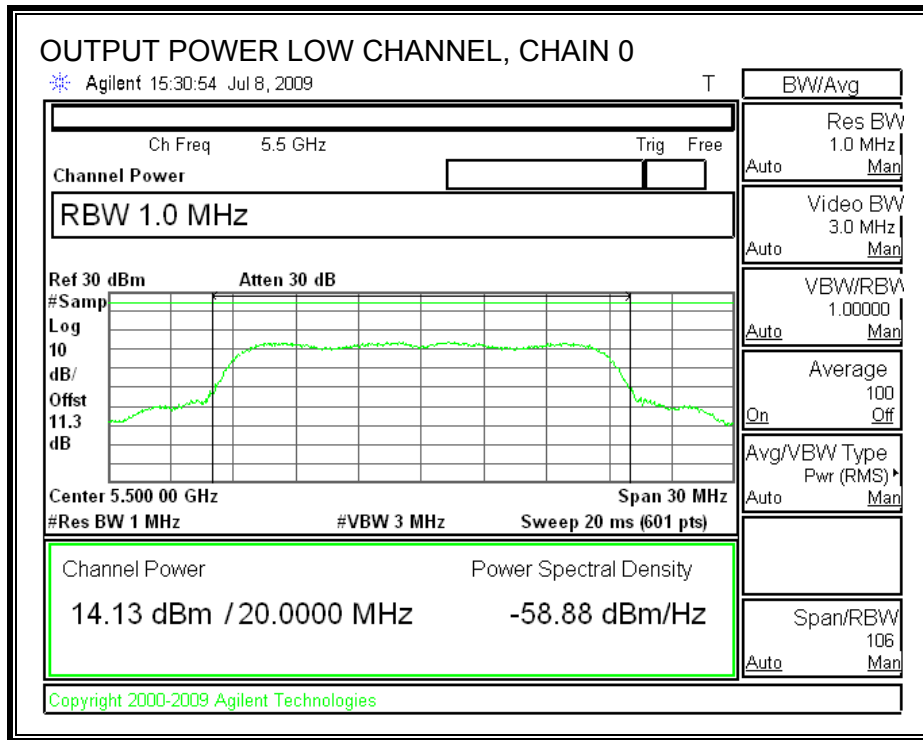

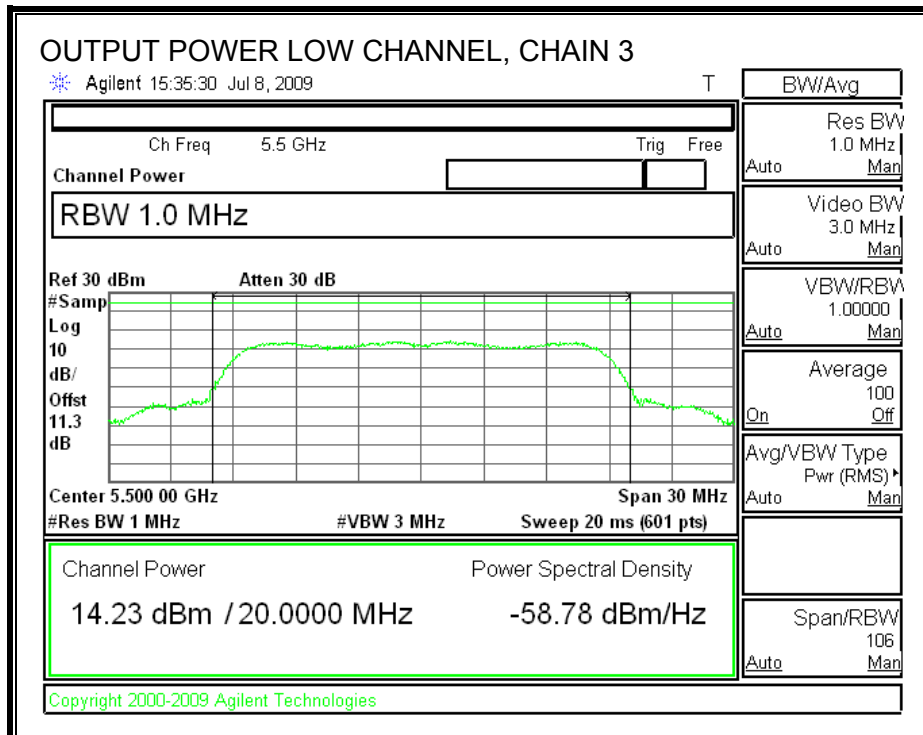
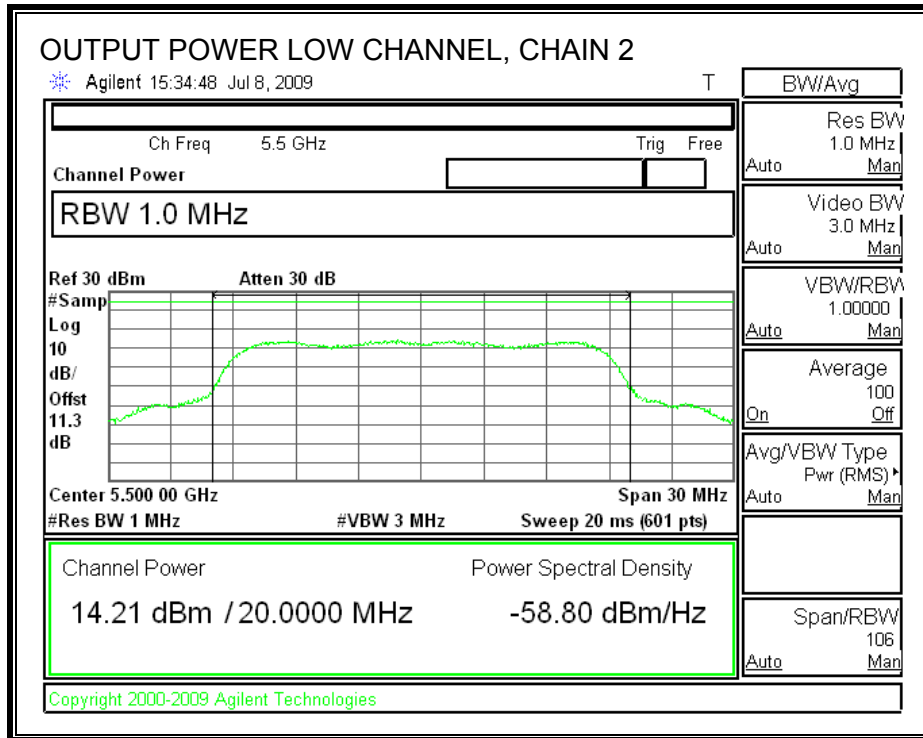

OUTPUT POWER, LOW CHANNEL

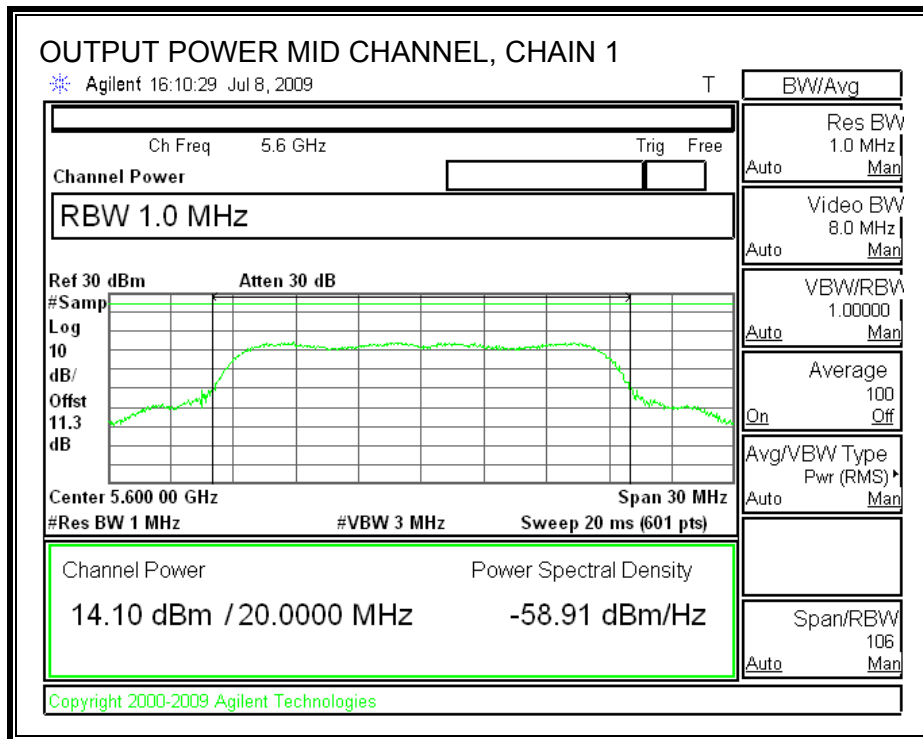
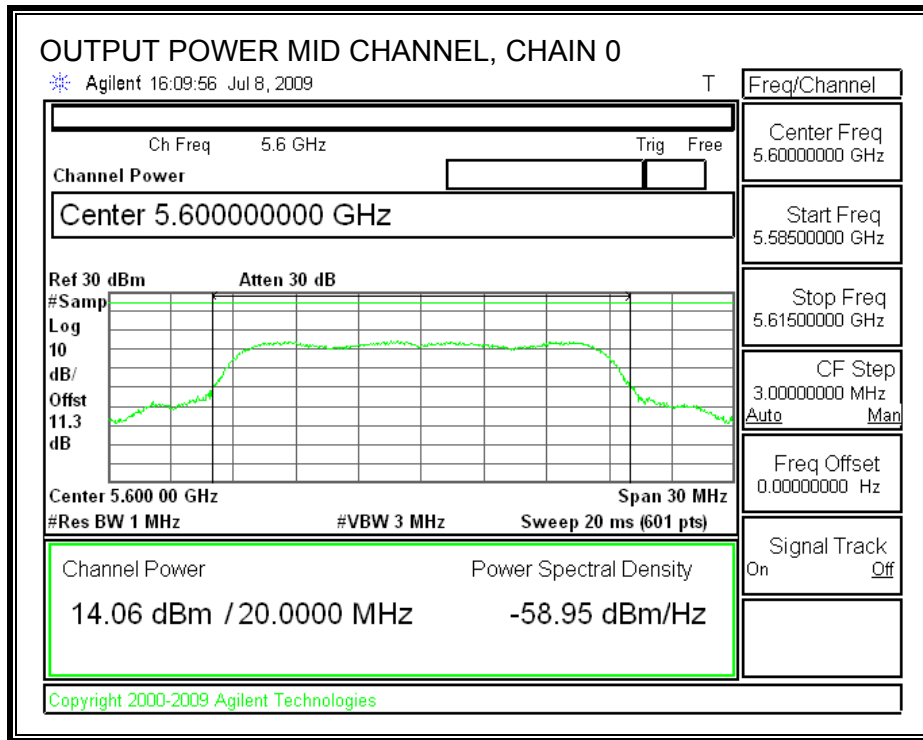

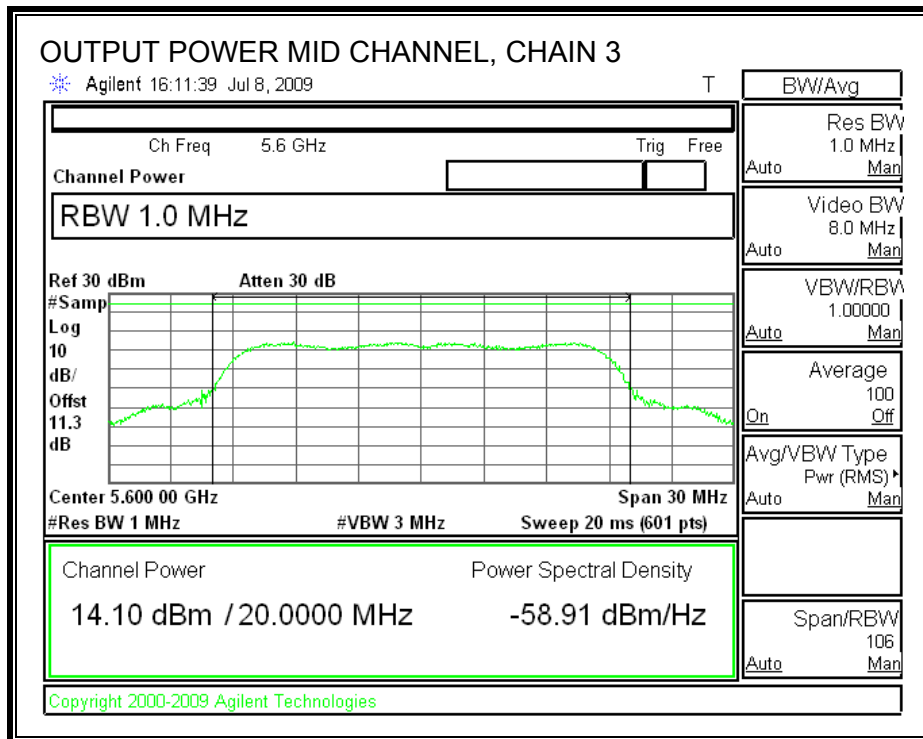
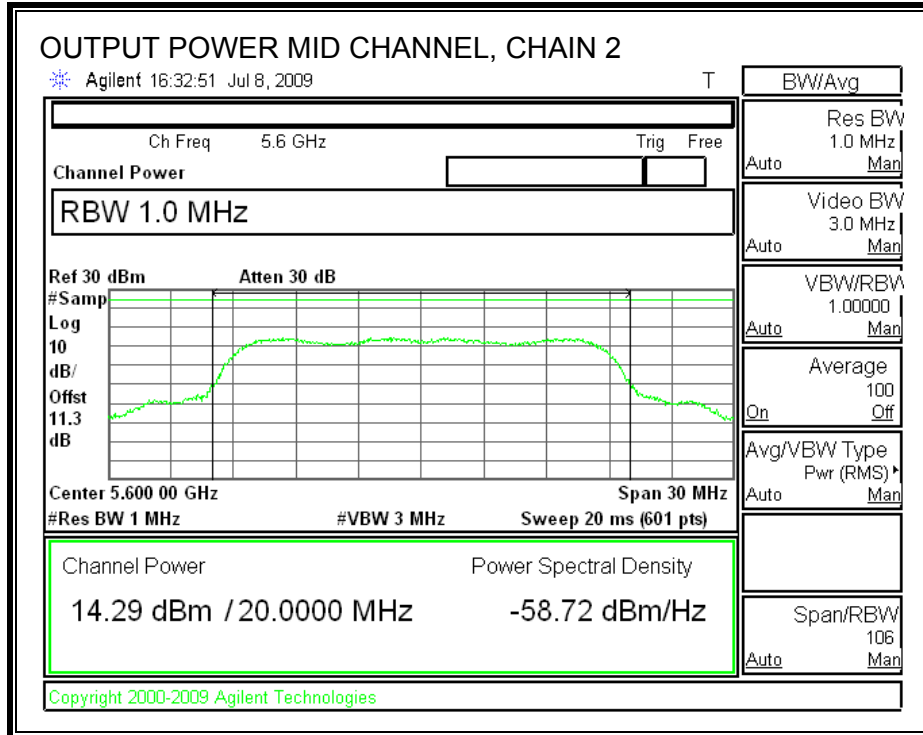

OUTPUT POWER, HIGH CHANNEL

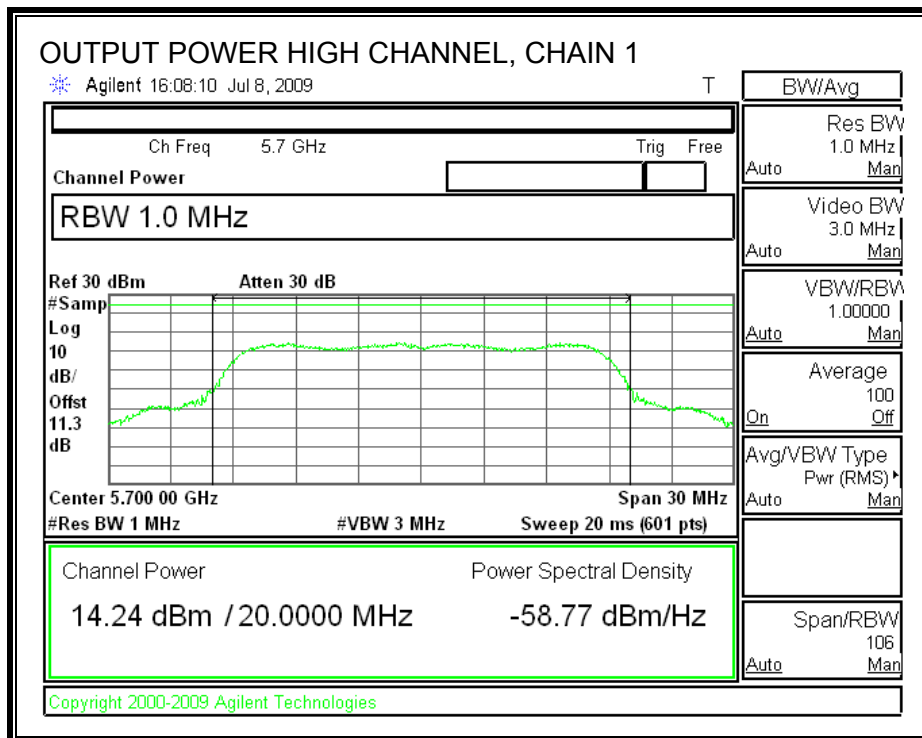
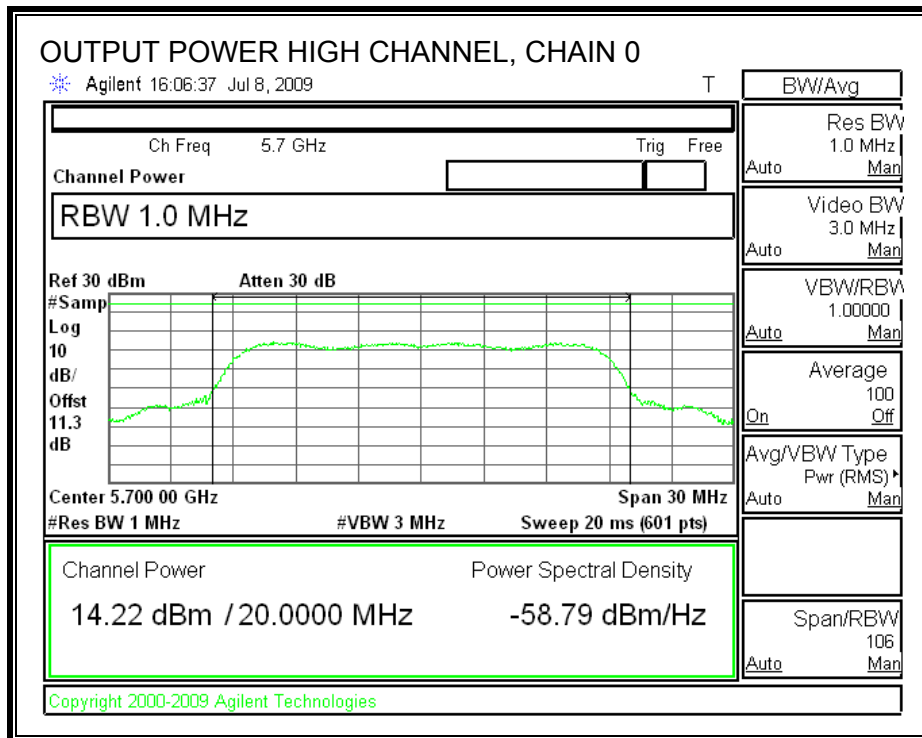

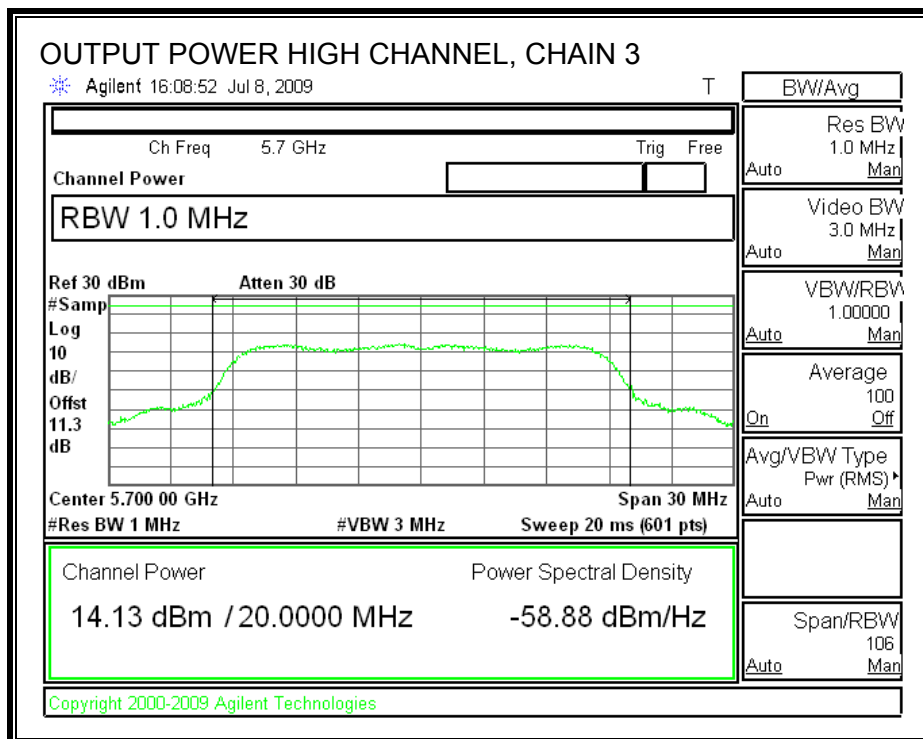
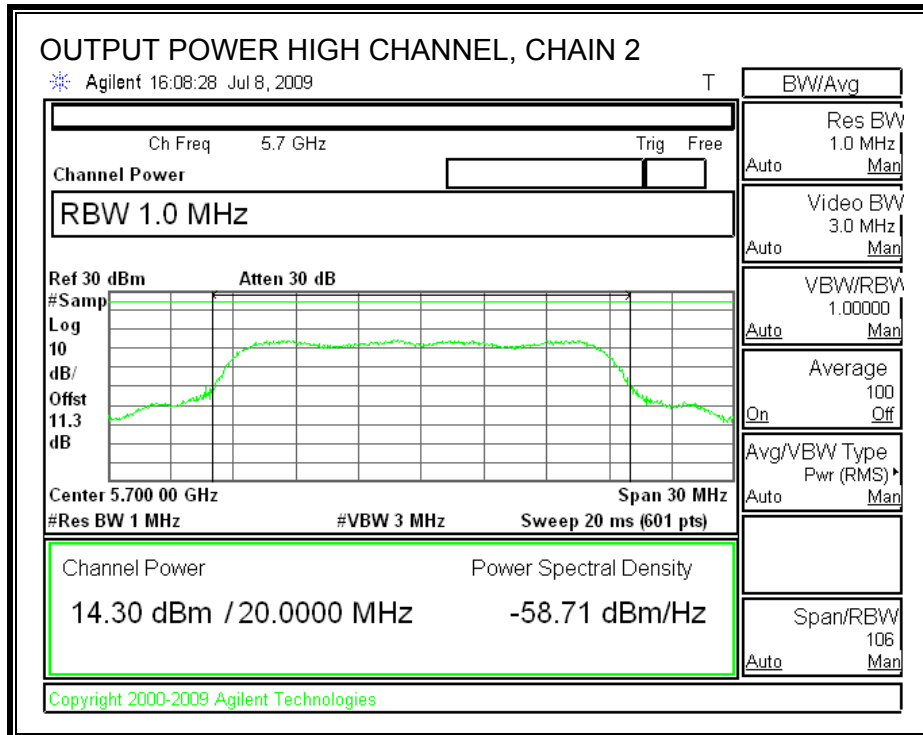

7.8.3. AVERAGE POWER

LIMITS

None; for reporting purposes only.

TEST PROCEDURE

The transmitter output is connected to a power meter.

The cable assembly insertion loss of 11.3 dB (including 10 dB pad and 1.3 dB cable) was entered as an offset in the power meter to allow for direct reading of power.

RESULTS

Channel	Frequency (MHz)	Chain 0 Power (dBm)	Chain 1 Power (dBm)	Chain 2 Power (dBm)	Chain 3 Power (dBm)
Low	5500	14.15	14.11	14.20	14.21
Middle	5600	14.25	14.21	14.30	14.32
High	5700	14.13	14.21	18.18	14.25

7.8.4. PEAK POWER SPECTRAL DENSITY

LIMITS

FCC §15.407 (a) (2)

IC RSS-210 A9.2 (2)

For the 5.47-5.725 GHz band, the peak power spectral density shall not exceed 11 dBm in any 1 MHz band. If transmitting antennas of directional gain greater than 6 dBi are used, both the peak transmit power and the peak power spectral density shall be reduced by the amount in dB that the directional gain of the antenna exceeds 6 dBi.

The maximum antenna gain is less than or equal to 6 dBi, therefore the limit is 11 dBm.

TEST PROCEDURE

The test is performed in accordance with FCC Public Notice: APPENDIX A Guidelines for Assessing Unlicensed National Information Infrastructure (U-NII) Devices – Part 15, Subpart E, August 2002. PPSD method #2 was used.

Preliminary tests on individual chains, and on all chains with a combiner, were performed. The worst-case configuration was with a combiner, therefore final test were performed with all chains feeding a combiner.

RESULTS

Channel	Frequency (MHz)	PSD with Combiner (dBm)	Limit (dBm)	Margin (dB)
Low	5500	10.61	11	-0.39
Middle	5600	10.40	11	-0.60
High	5700	10.66	11	-0.34

POWER SPECTRAL DENSITY

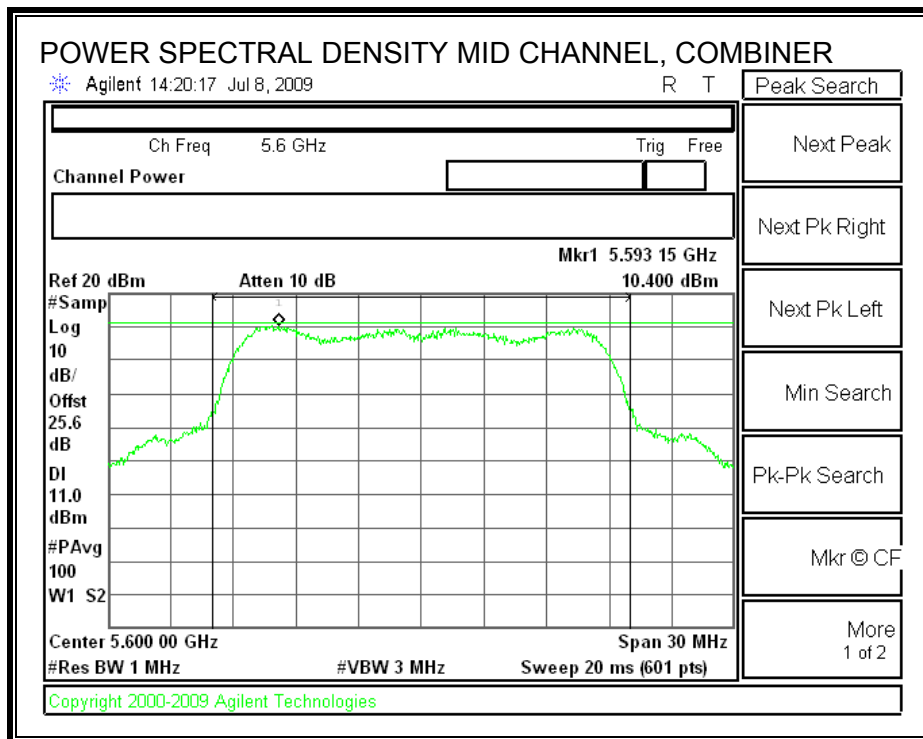
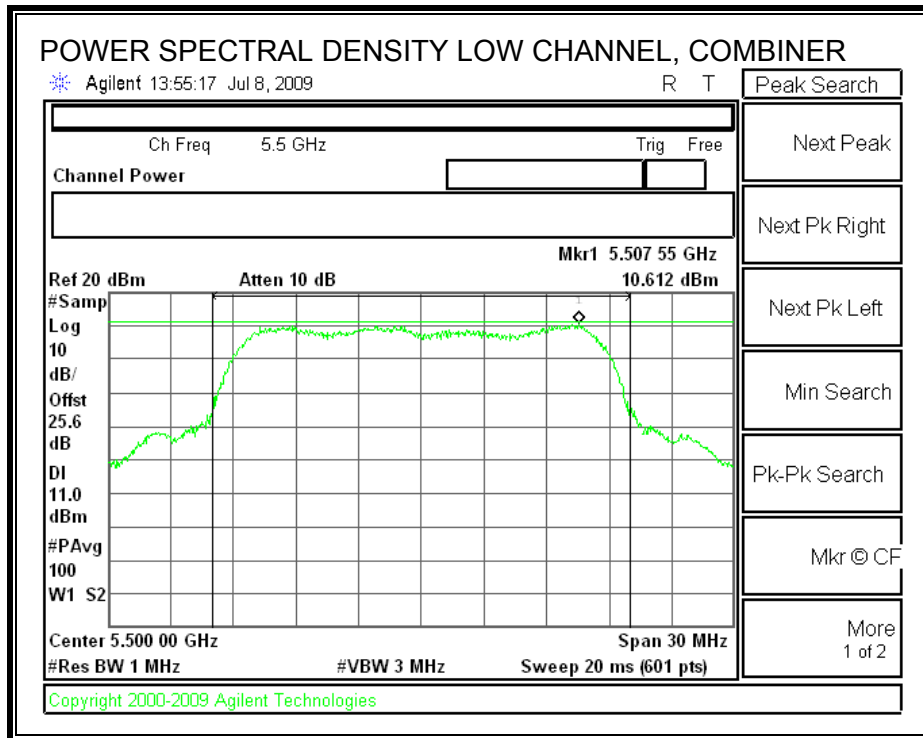

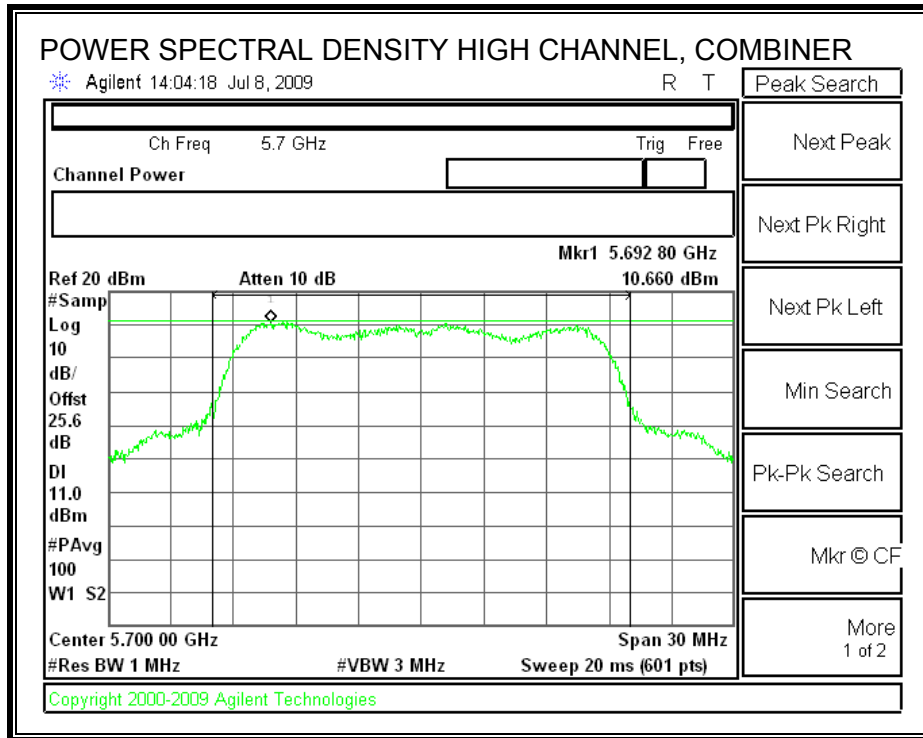

7.8.5. PEAK EXCURSION

LIMITS

FCC §15.407 (a) (6)

The ratio of the peak excursion of the modulation envelope (measured using a peak hold function) to the peak transmit power (measured as specified above) shall not exceed 13 dB across any 1 MHz bandwidth or the emission bandwidth whichever is less.

TEST PROCEDURE

The transmitter outputs are connected to the spectrum analyzer via a combiner.

The test is performed in accordance with FCC Public Notice: APPENDIX A Guidelines for Assessing Unlicensed National Information Infrastructure (U-NII) Devices – Part 15, Subpart E, August 2002.

Since Method # 1 was used for peak power measurements, Method # 1 settings are used for the second PPSD trace.

RESULTS

Channel	Frequency (MHz)	Peak Excursion (dB)	Limit (dB)	Margin (dB)
Low	5500	10.48	13	-2.52
Middle	5600	10.37	13	-2.63
High	5700	9.40	13	-3.60

PEAK EXCURSION

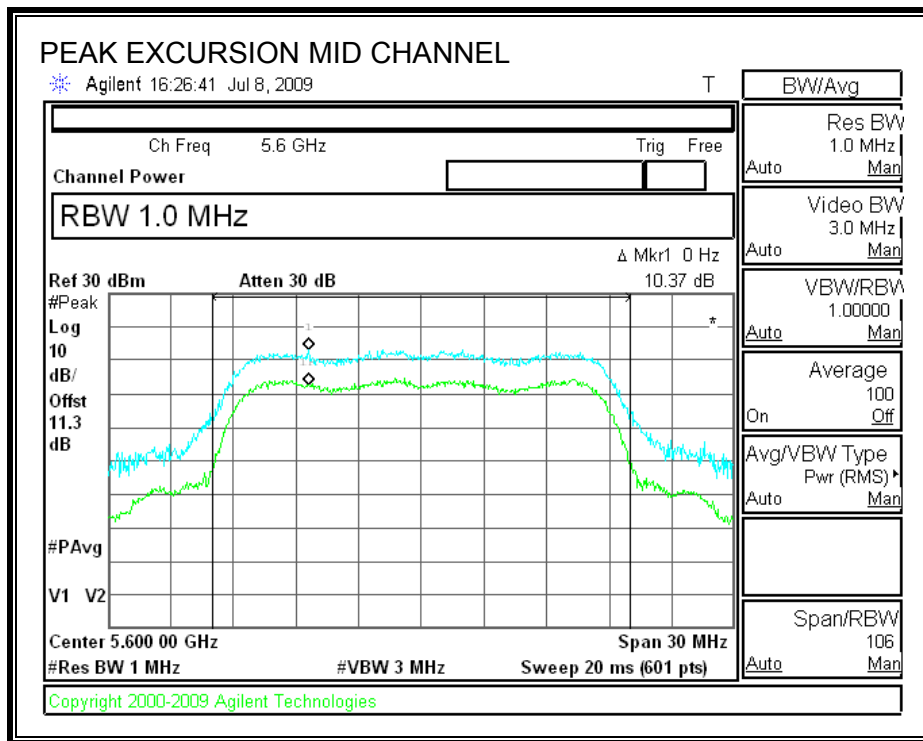
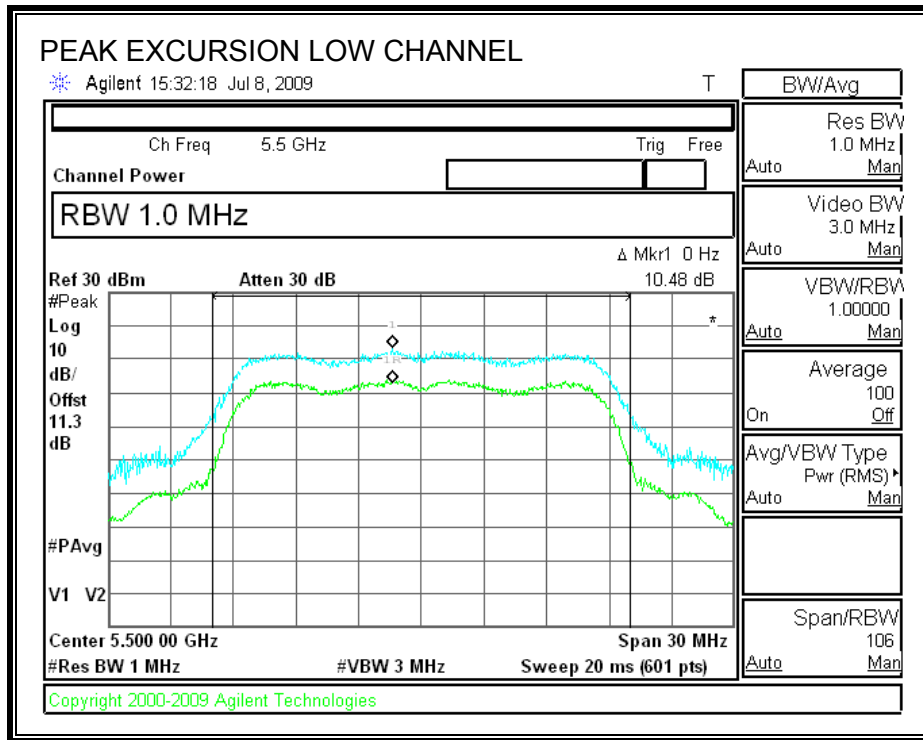

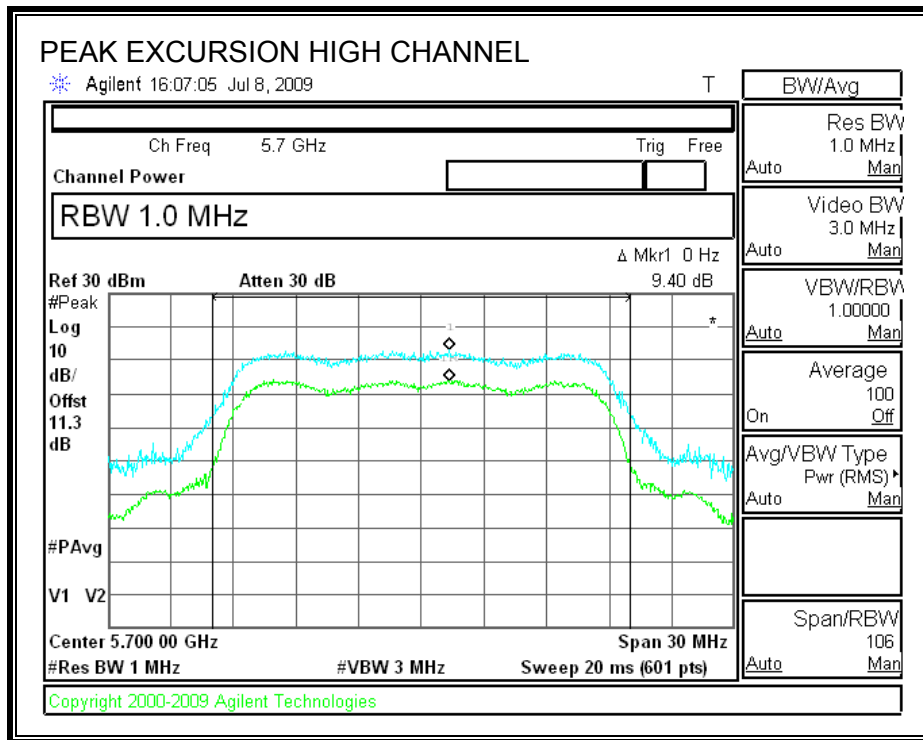

7.8.6. CONDUCTED SPURIOUS EMISSIONS

LIMITS

FCC §15.407 (b) (3)

IC RSS-210 A9.3 (3)

For transmitters operating in the 5.47-5.725 GHz band: all emissions outside of the 5.47-5.725 GHz band shall not exceed an EIRP of -27 dBm / MHz.

TEST PROCEDURE

Conducted RF measurements of the transmitter output are made to confirm that the EUT antenna port conducted emissions meet the specified limit and to identify any spurious signals that require further investigation or measurements on the radiated emissions site.

The transmitter output is connected to the spectrum analyzer. The resolution bandwidth is set to 1 MHz. The video bandwidth is set to 1 MHz. Peak detection measurements are compared to EIRP limit, adjusted for the maximum antenna gain.

Measurements are made over the 30 MHz to 40 GHz range with the transmitter set to the lowest, middle, and highest channels.

Preliminary tests on individual chains, and on all chains with a combiner, were performed. The worst-case configuration was with a combiner, therefore final test were performed with all chains feeding a combiner.

LOW CHANNEL SPURIOUS EMISSIONS

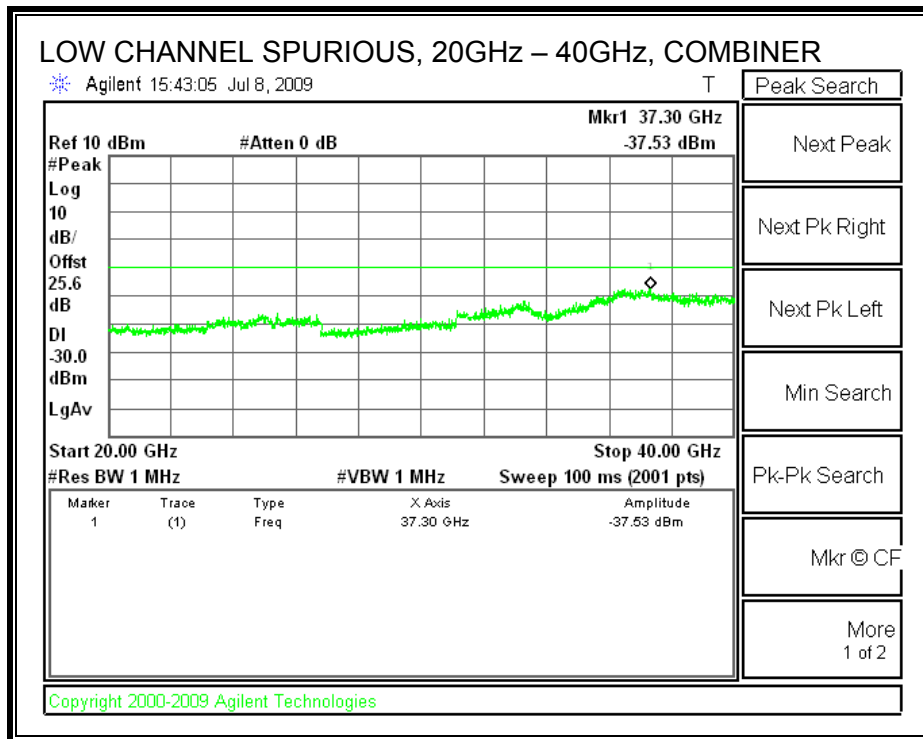
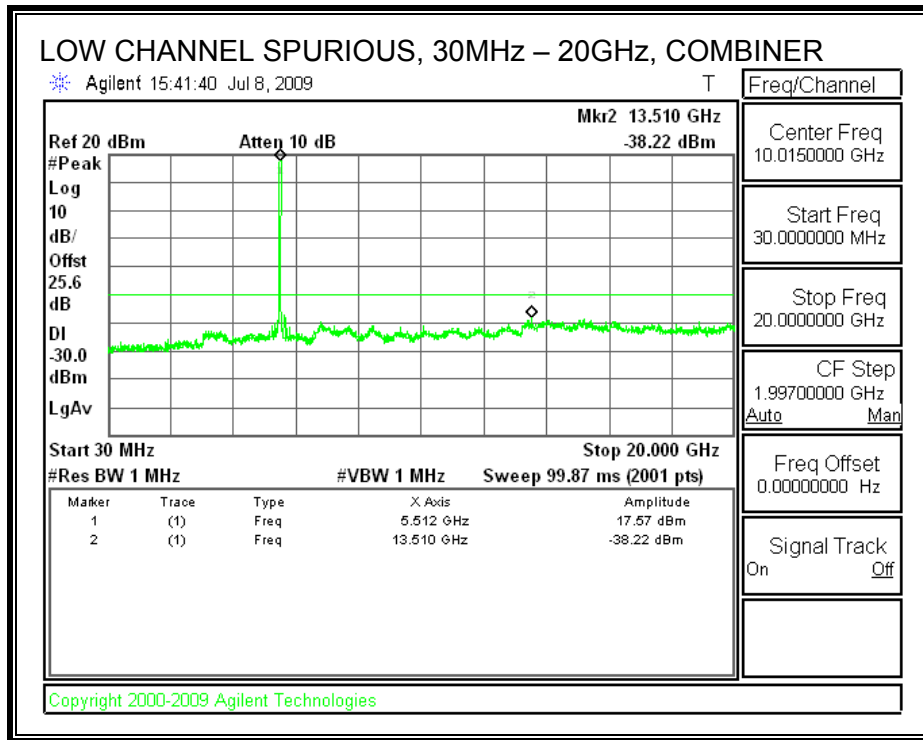

MID CHANNEL SPURIOUS EMISSIONS

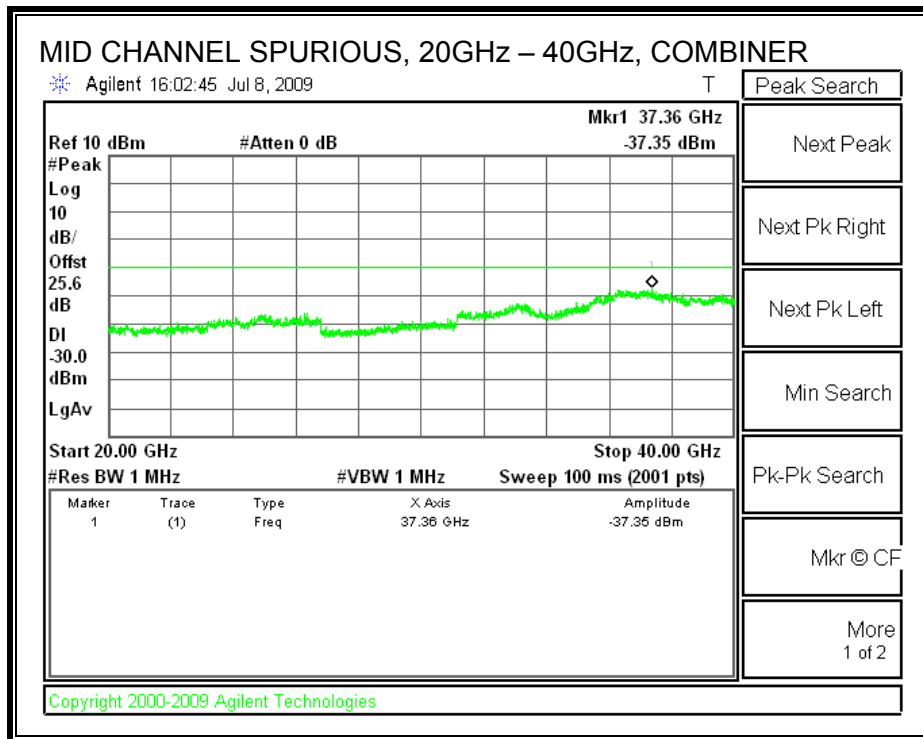
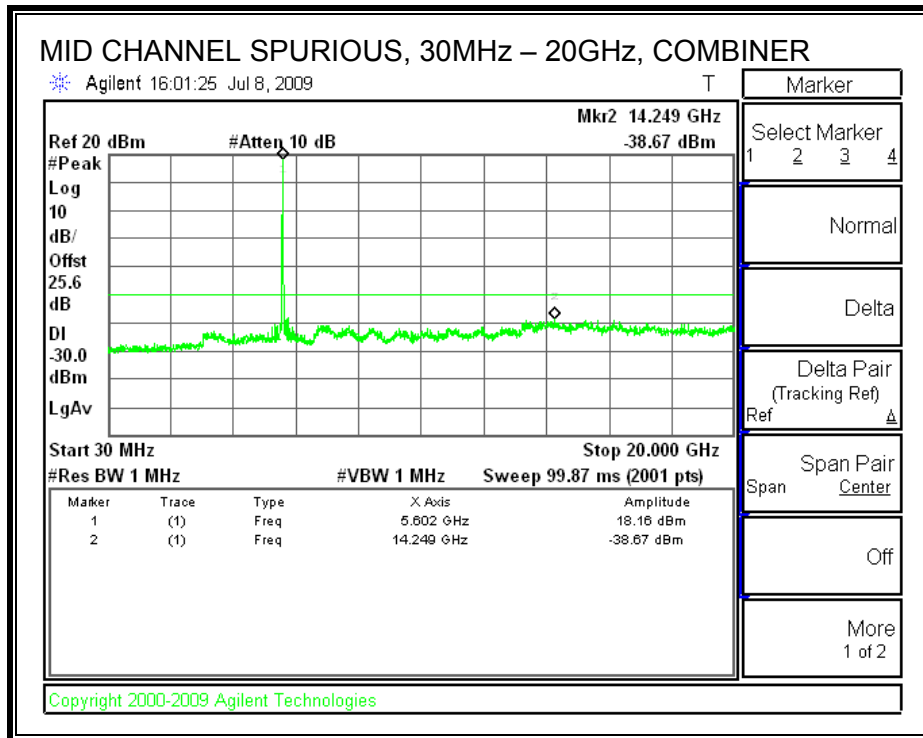

HIGH CHANNEL SPURIOUS EMISSIONS

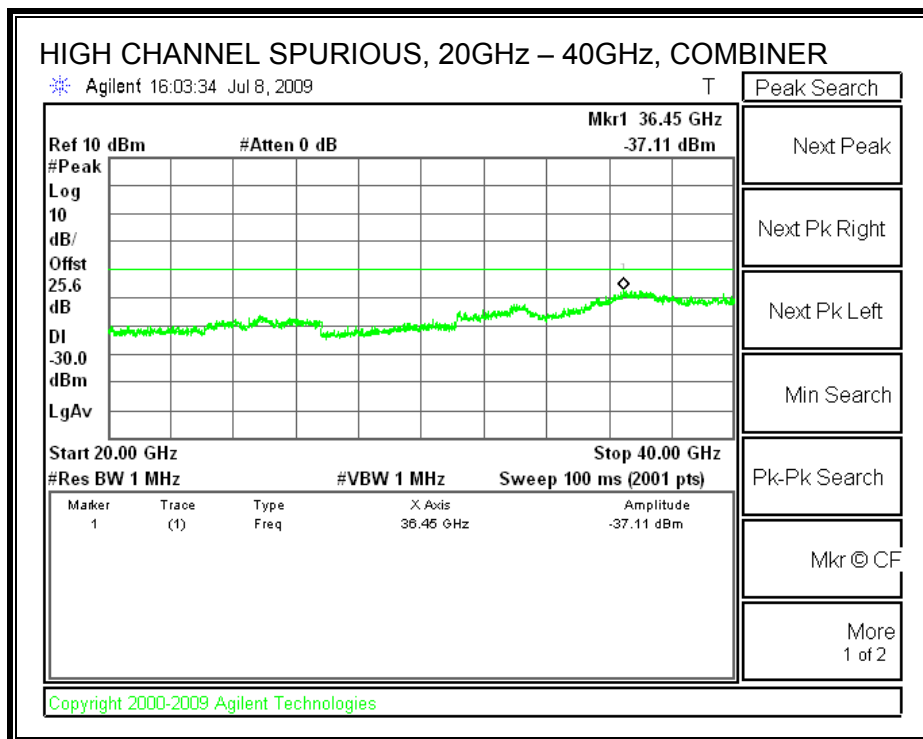
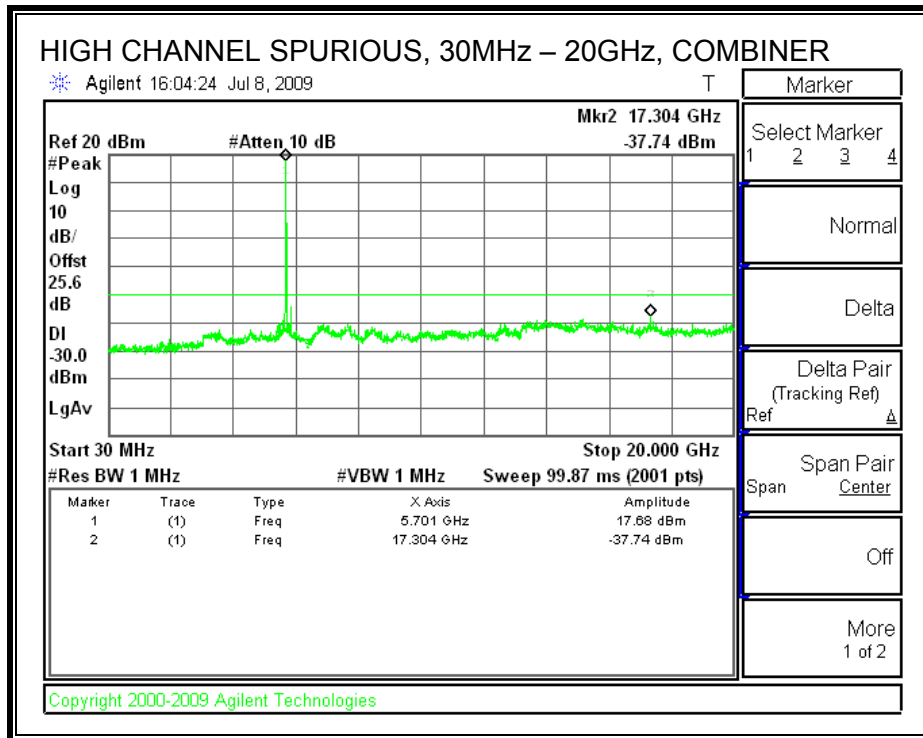

7.9. 5.6 GHz BAND CHANNEL TESTS FOR 802.11n HT40 MODE

7.9.1. 99% & 26 dB BANDWIDTH

LIMITS

None; for reporting purposes only.

TEST PROCEDURE

The transmitter output is connected to the spectrum analyzer. The RBW is set to 1% to 3% of the bandwidth. The VBW is set to 3 times the RBW. The sweep time is coupled. The spectrum analyzer internal bandwidth measurement function is utilized.

RESULTS

Channel	Frequency (MHz)	99% OBW (MHz)	26 dB BW (MHz)
Low	5510	35.9963	43.640
Middle	5590	36.2049	42.851
High	5670	35.8572	44.129

99% & 26 dB BANDWIDTH

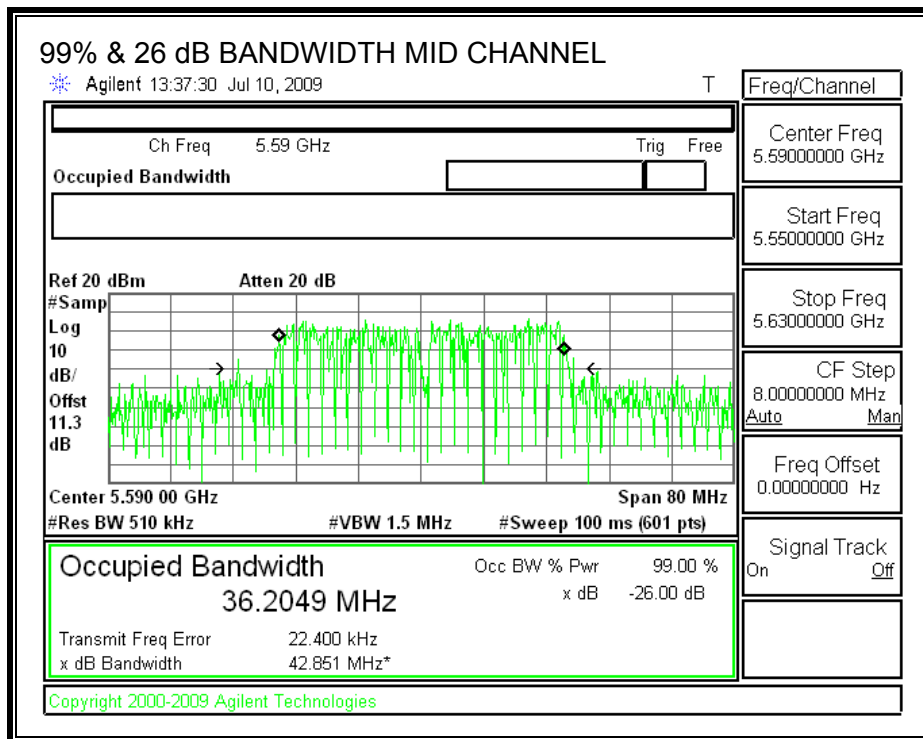
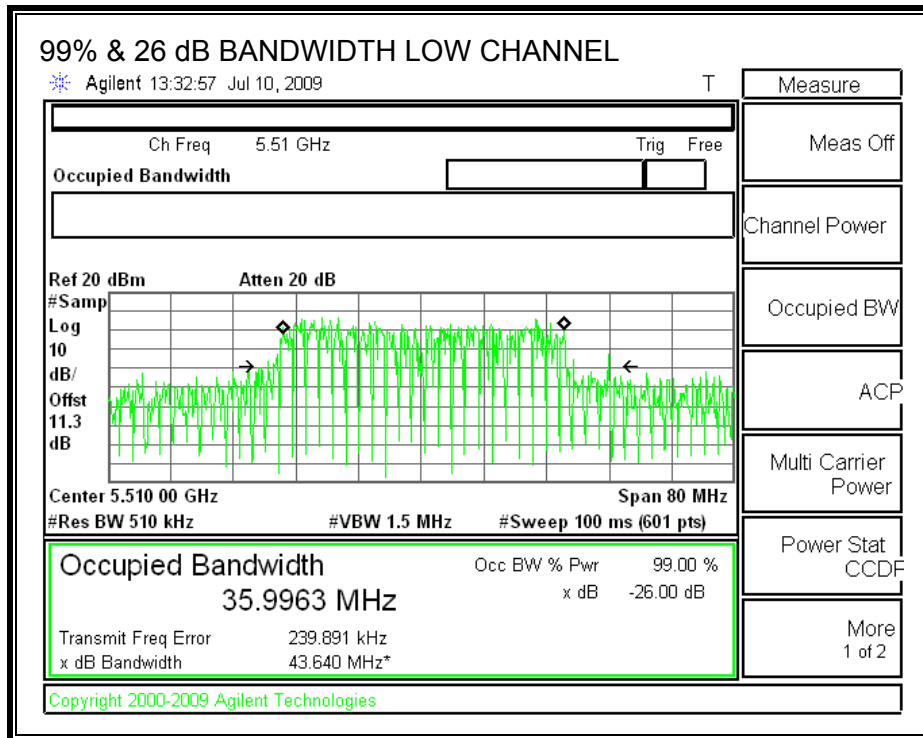

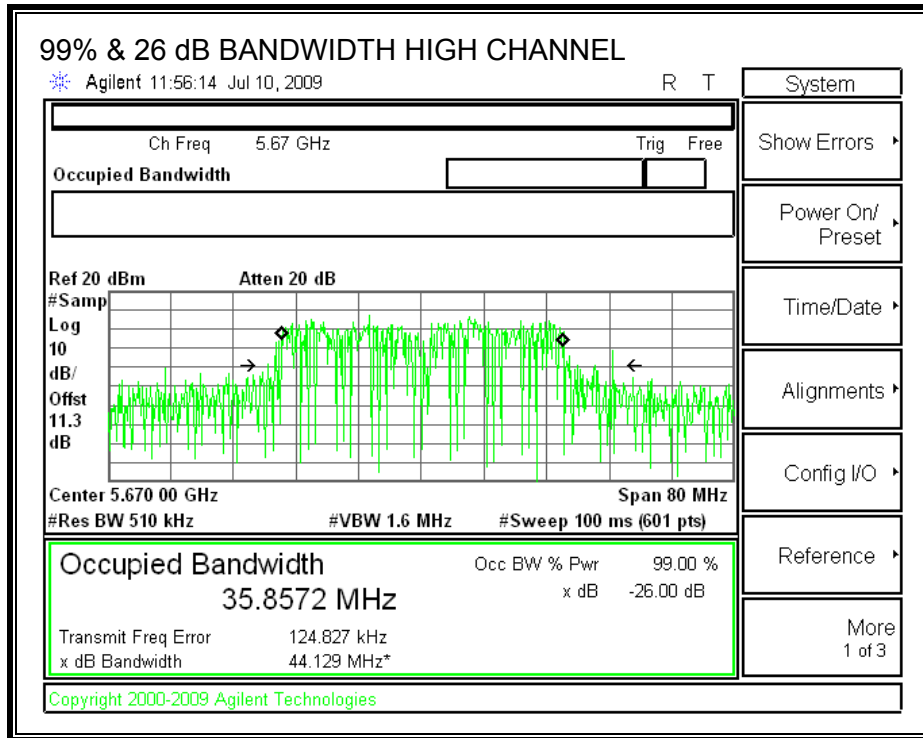

7.9.2. OUTPUT POWER

LIMITS

FCC §15.407 (a) (2)
 IC RSS-210 A9.2 (2)

For the 5.47-5.725 GHz band, the maximum conducted output power over the frequency band of operation shall not exceed the lesser of 250 mW or 11 dBm + 10 log B, where B is the 26-dB emission bandwidth in MHz. If transmitting antennas of directional gain greater than 6 dBi are used, both the peak transmit power and the peak power spectral density shall be reduced by the amount in dB that the directional gain of the antenna exceeds 6 dBi.

TEST PROCEDURE

The test is performed in accordance with FCC Public Notice: APPENDIX A Guidelines for Assessing Unlicensed National Information Infrastructure (U-NII) Devices – Part 15, Subpart E, August 2002.

The transmitter output operates continuously therefore Method # 1 is used.

RESULTS

Limit

Channel	Freq (MHz)	Fixed Limit (dBm)	B (MHz)	11 + 10 Log B Limit (dBm)	Antenna Gain (dBi)	Limit (dBm)
Low	5510	24	43.640	27.40	3	24.00
Mid	5590	24	42.851	27.32	3	24.00
High	5670	24	44.129	27.45	3	24.00

Individual Chain Results

Channel	Freq (MHz)	Chain 0 Power (dBm)	Chain 1 Power (dBm)	Chain 2 Power (dBm)	Chain 3 Power (dBm)	Total Power (dBm)	Limit (dBm)	Margin (dB)
Low	5510	11.48	11.55	11.30	11.63	17.51	24.00	-6.49
Mid	5590	17.81	17.87	17.28	17.53	23.65	24.00	-0.35
High	5670	14.49	14.29	14.19	13.95	20.25	24.00	-3.75

OUTPUT POWER, LOW CHANNEL

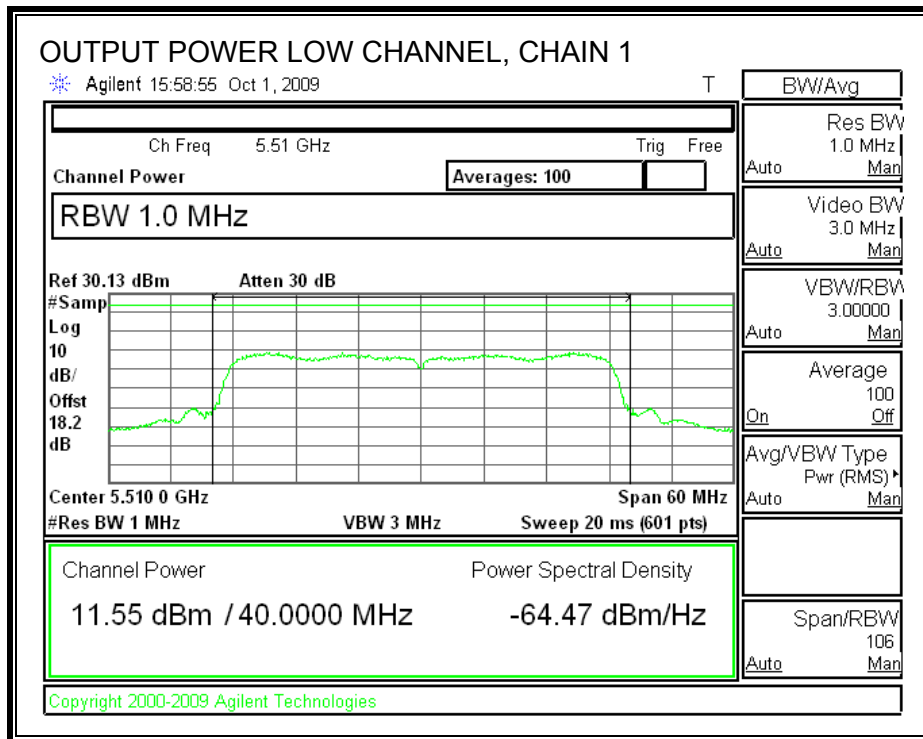
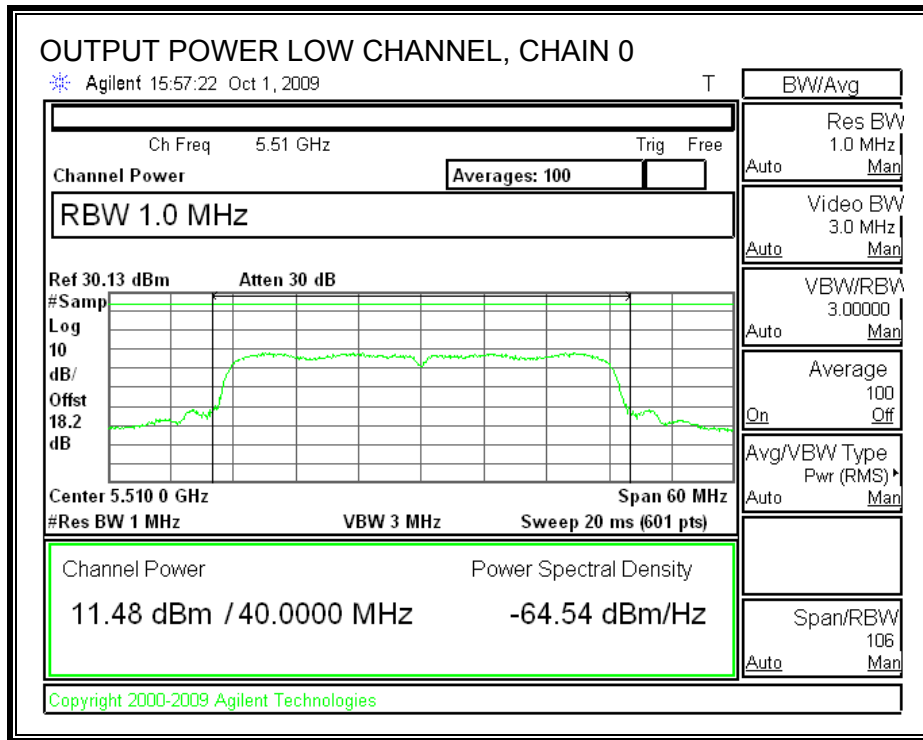

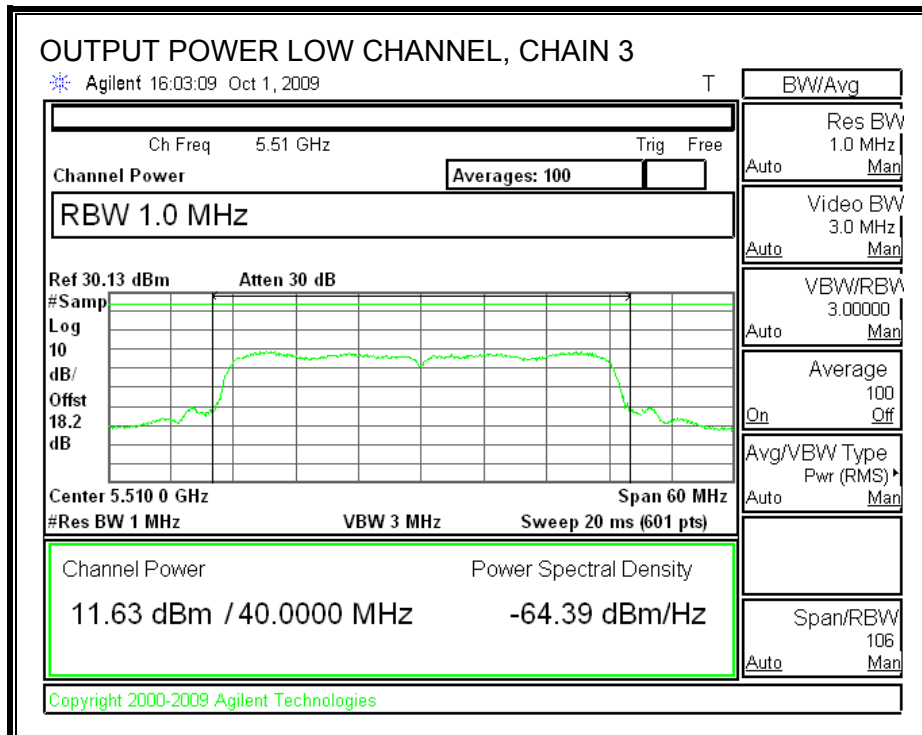
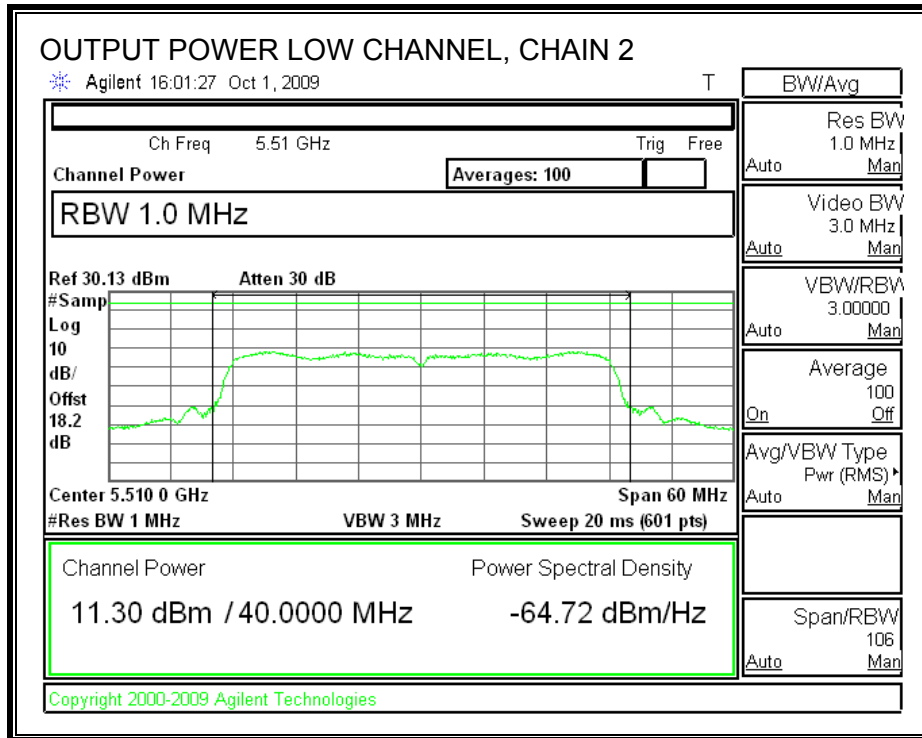

OUTPUT POWER, MID CHANNEL

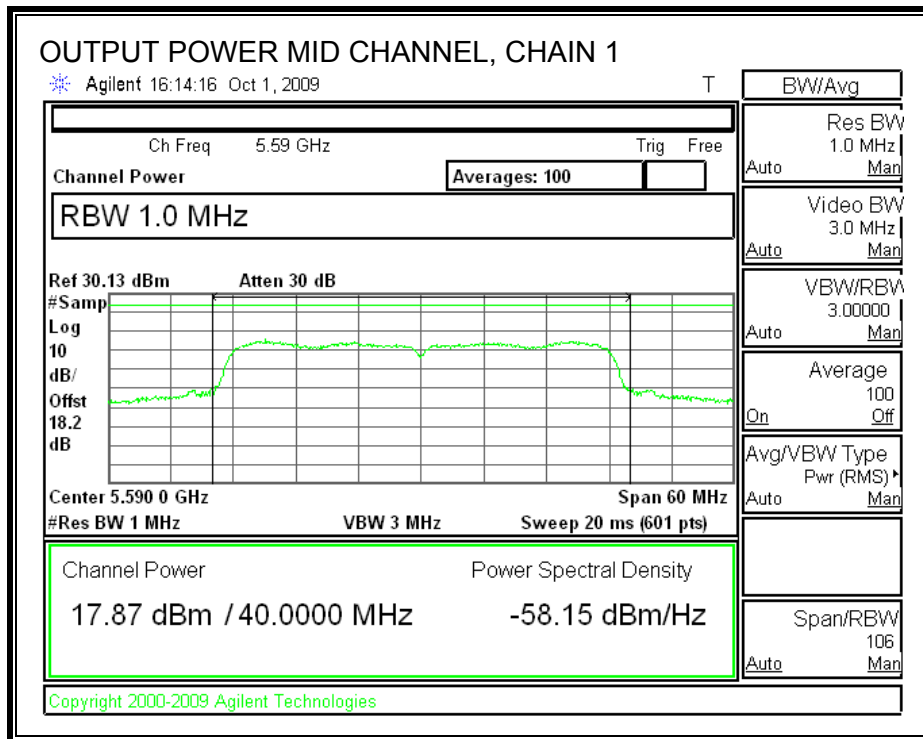
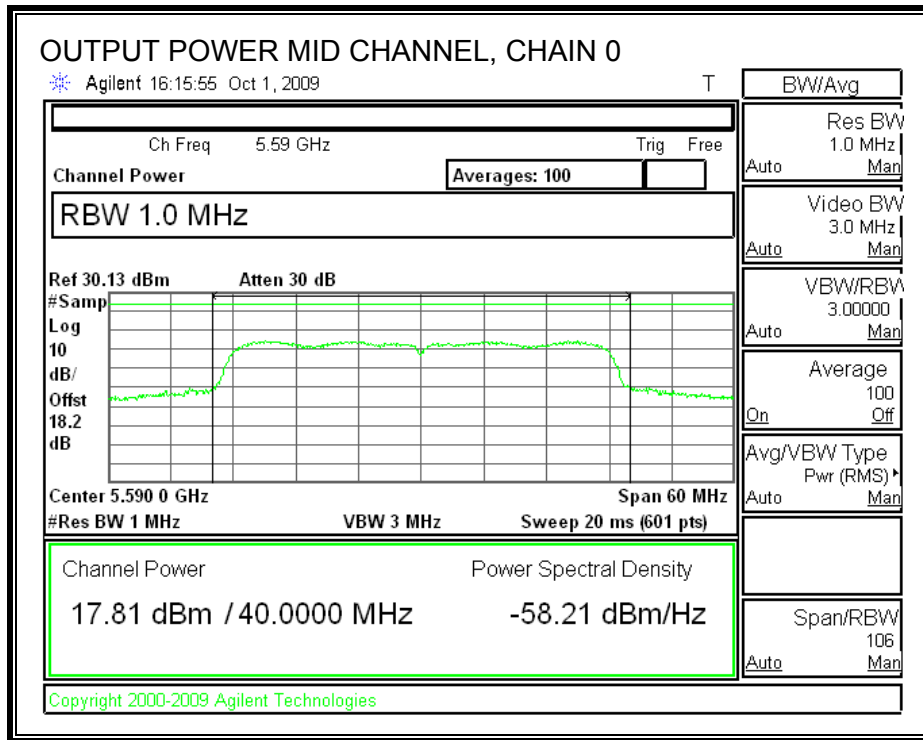

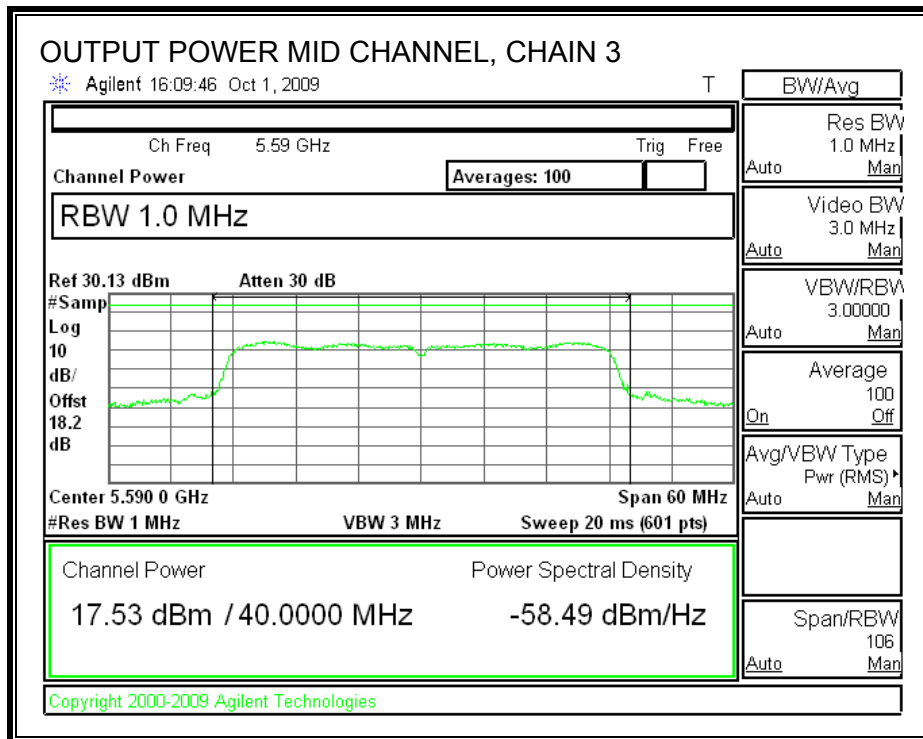
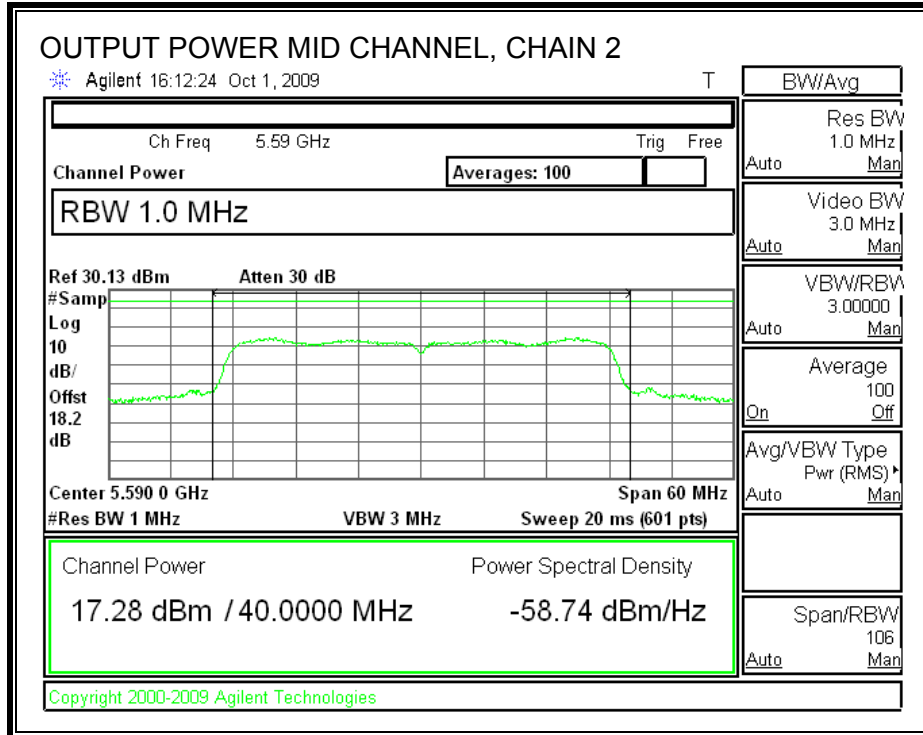

OUTPUT POWER, HIGH CHANNEL

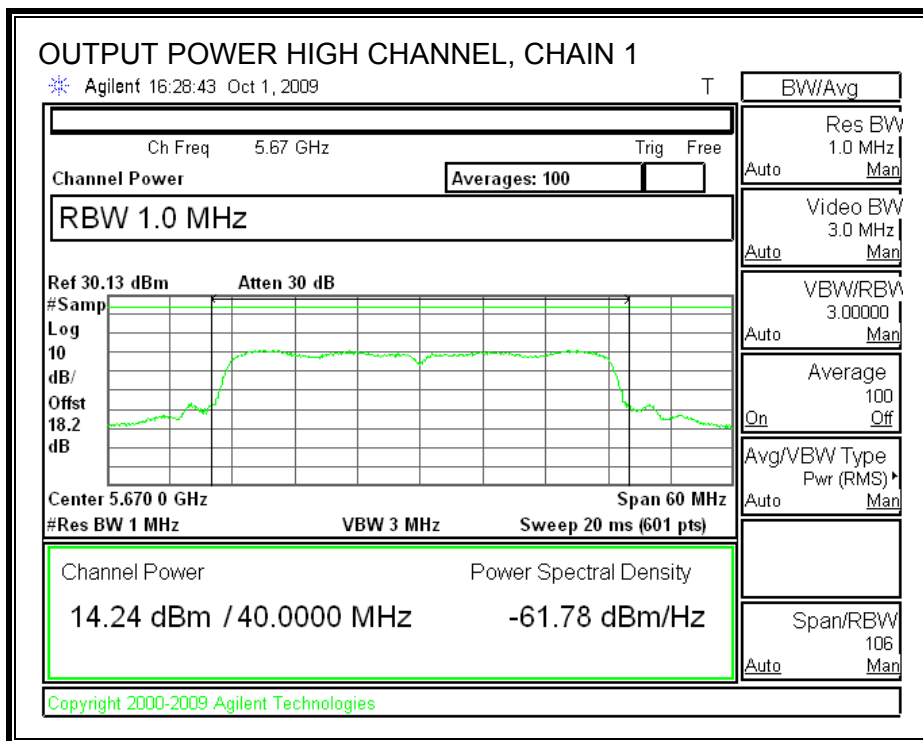
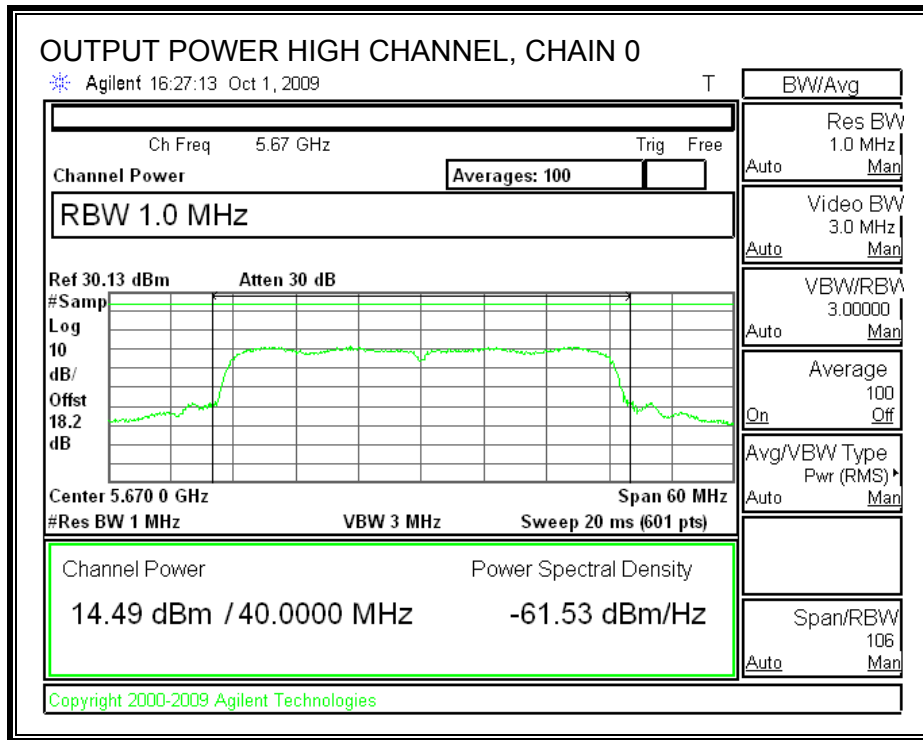

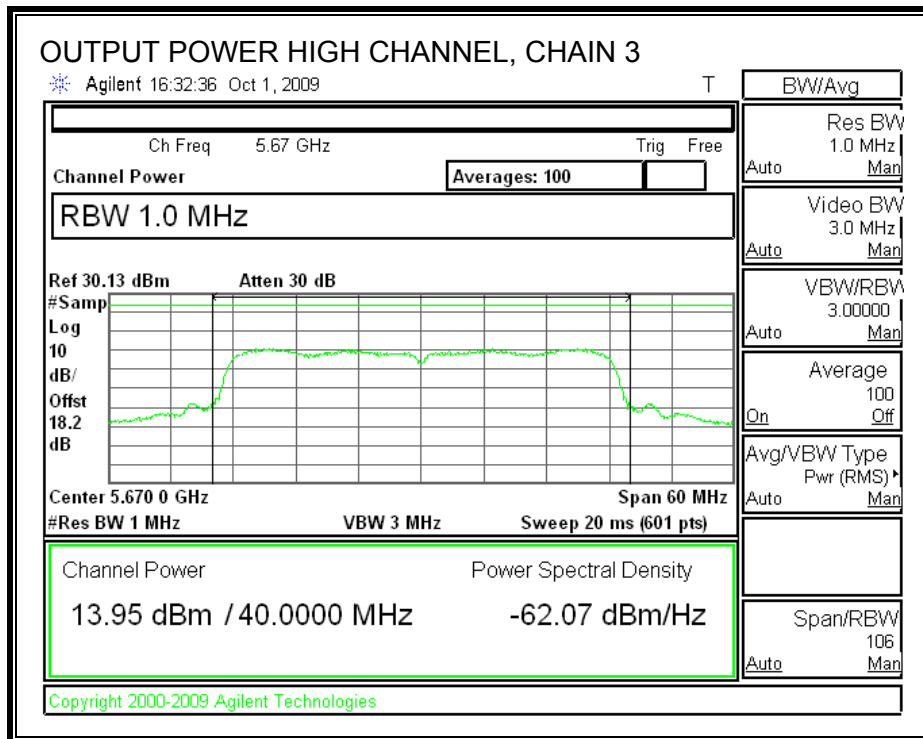
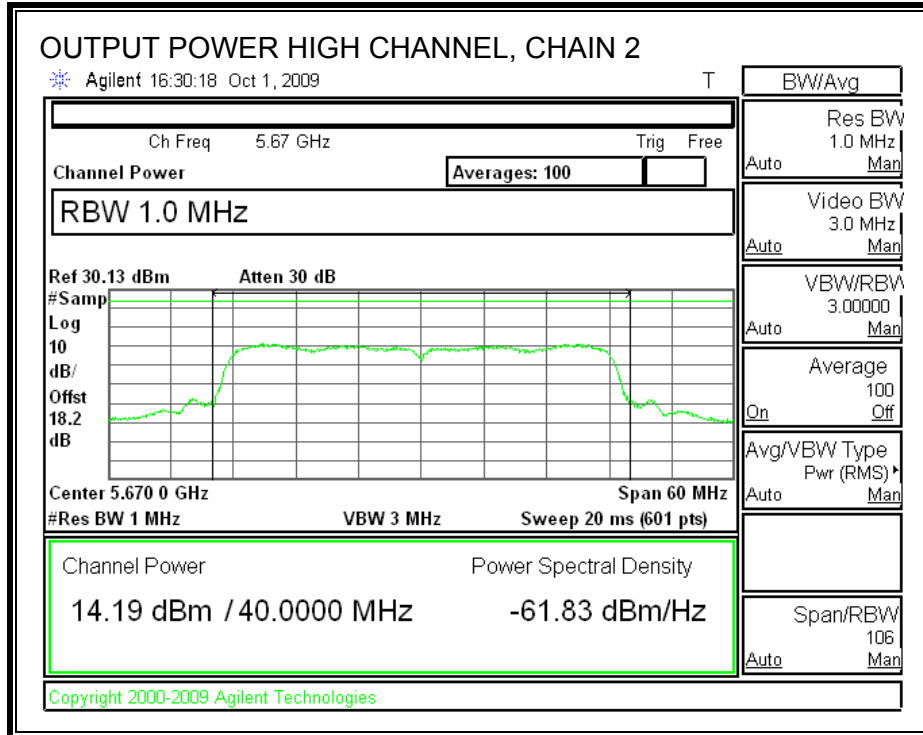

7.9.3. AVERAGE POWER

LIMITS

None; for reporting purposes only.

TEST PROCEDURE

The transmitter output is connected to a power meter.

The cable assembly insertion loss of 11.3 dB (including 10 dB pad and 1.3 dB cable) was entered as an offset in the power meter to allow for direct reading of power.

RESULTS

Channel	Frequency (MHz)	Chain 0 Power (dBm)	Chain 1 Power (dBm)	Chain 2 Power (dBm)	Chain 3 Power (dBm)
Low	5510	11.44	11.53	11.30	11.51
Middle	5590	18.00	18.06	17.45	17.67
High	5670	14.45	14.21	14.15	13.92

7.9.4. PEAK POWER SPECTRAL DENSITY

LIMITS

FCC §15.407 (a) (2)

IC RSS-210 A9.2 (2)

For the 5.47-5.725 GHz band, the peak power spectral density shall not exceed 11 dBm in any 1 MHz band. If transmitting antennas of directional gain greater than 6 dBi are used, both the peak transmit power and the peak power spectral density shall be reduced by the amount in dB that the directional gain of the antenna exceeds 6 dBi.

The maximum antenna gain is less than or equal to 6 dBi, therefore the limit is 11 dBm.

TEST PROCEDURE

The test is performed in accordance with FCC Public Notice: APPENDIX A Guidelines for Assessing Unlicensed National Information Infrastructure (U-NII) Devices – Part 15, Subpart E, August 2002. PPSD method #2 was used.

Preliminary tests on individual chains, and on all chains with a combiner, were performed. The worst-case configuration was with a combiner, therefore final test were performed with all chains feeding a combiner.

RESULTS

Channel	Frequency (MHz)	PSD with Combiner (dBm)	Limit (dBm)	Margin (dB)
Low	5510	4.159	11	-6.84
Middle	5590	10.060	11	-0.94
High	5670	6.028	11	-4.97

POWER SPECTRAL DENSITY

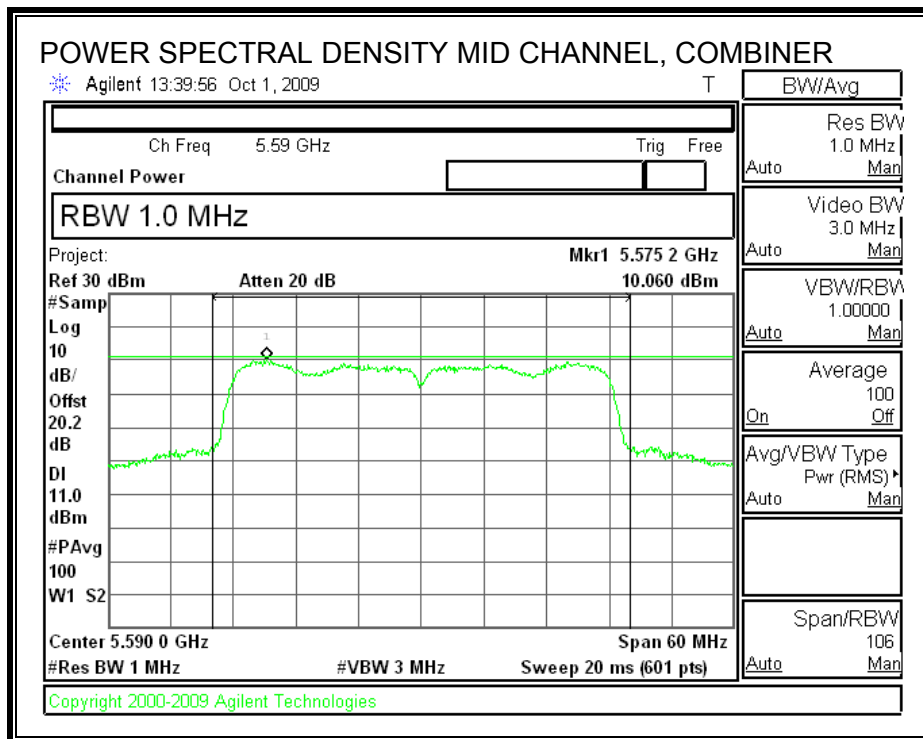
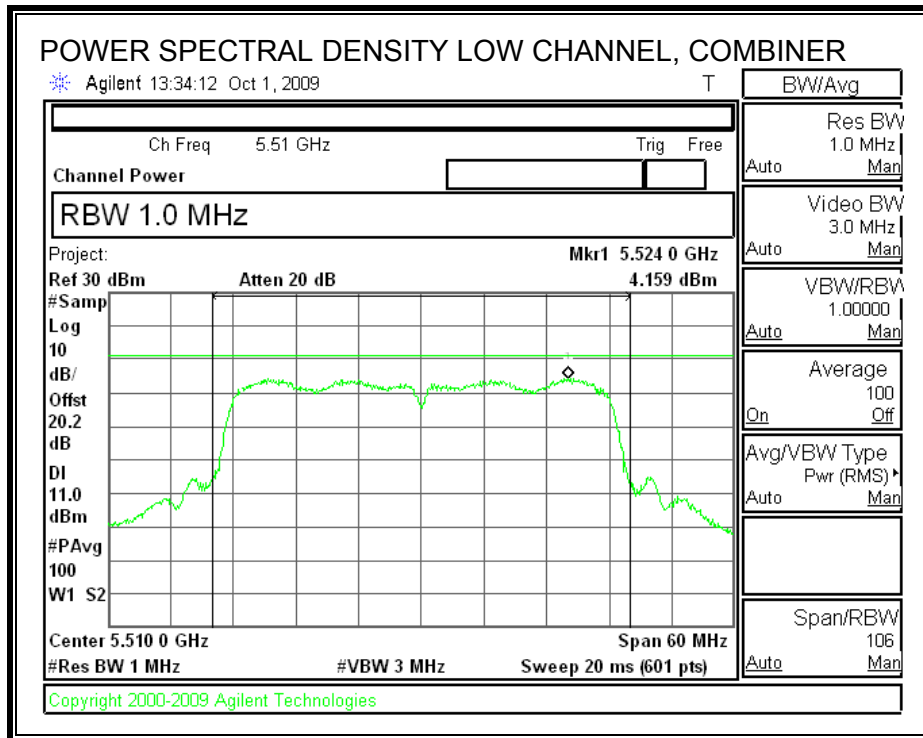

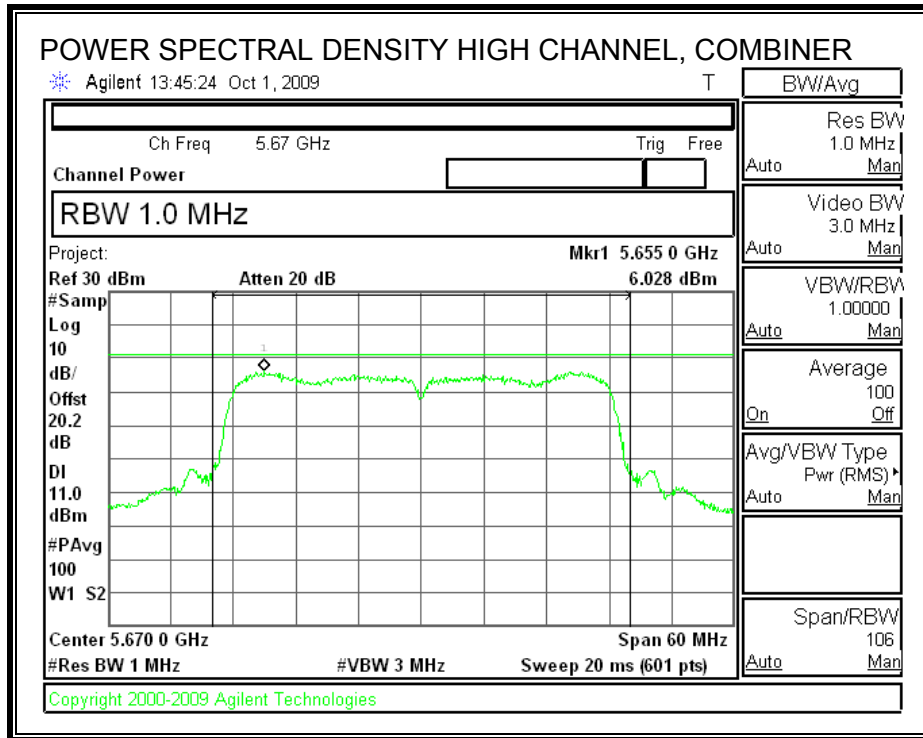

7.9.5. PEAK EXCURSION

LIMITS

FCC §15.407 (a) (6)

The ratio of the peak excursion of the modulation envelope (measured using a peak hold function) to the peak transmit power (measured as specified above) shall not exceed 13 dB across any 1 MHz bandwidth or the emission bandwidth whichever is less.

TEST PROCEDURE

The transmitter outputs are connected to the spectrum analyzer via a combiner.

The test is performed in accordance with FCC Public Notice: APPENDIX A Guidelines for Assessing Unlicensed National Information Infrastructure (U-NII) Devices – Part 15, Subpart E, August 2002.

Since Method # 1 was used for peak power measurements, Method # 1 settings are used for the second PPSD trace.

RESULTS

Channel	Frequency (MHz)	Peak Excursion (dB)	Limit (dB)	Margin (dB)
Low	5510	9.92	13	-3.08
Middle	5590	7.79	13	-5.21
High	5670	9.78	13	-3.22

PEAK EXCURSION

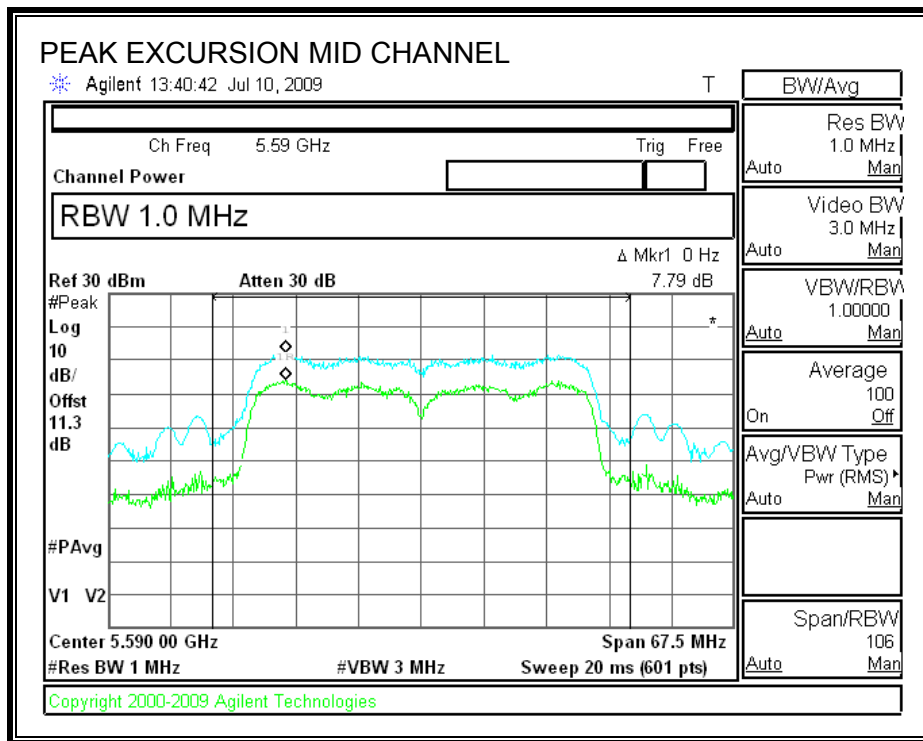
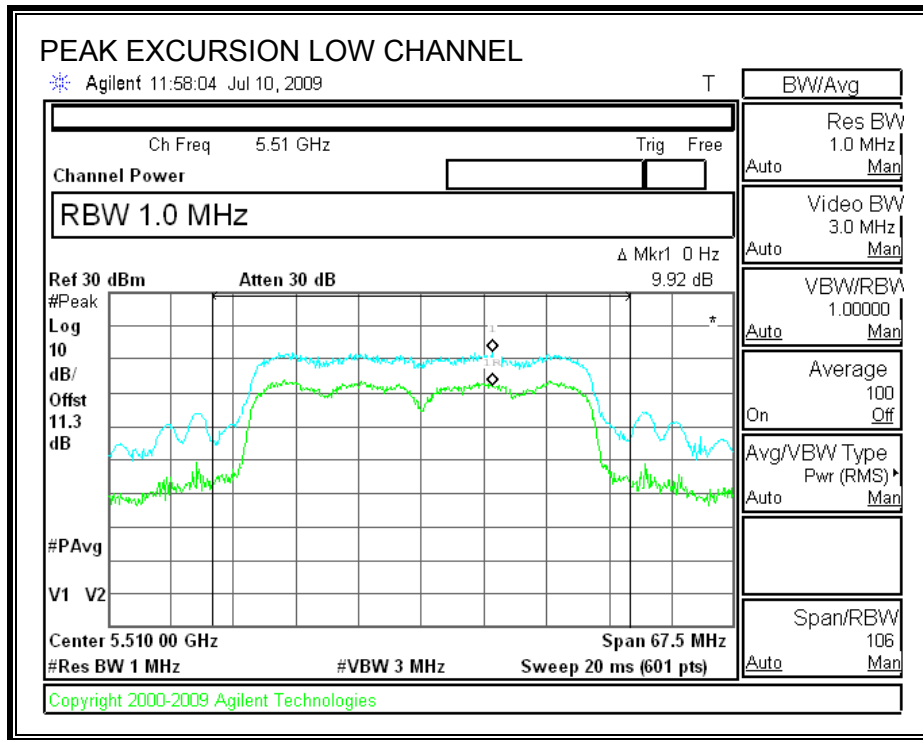

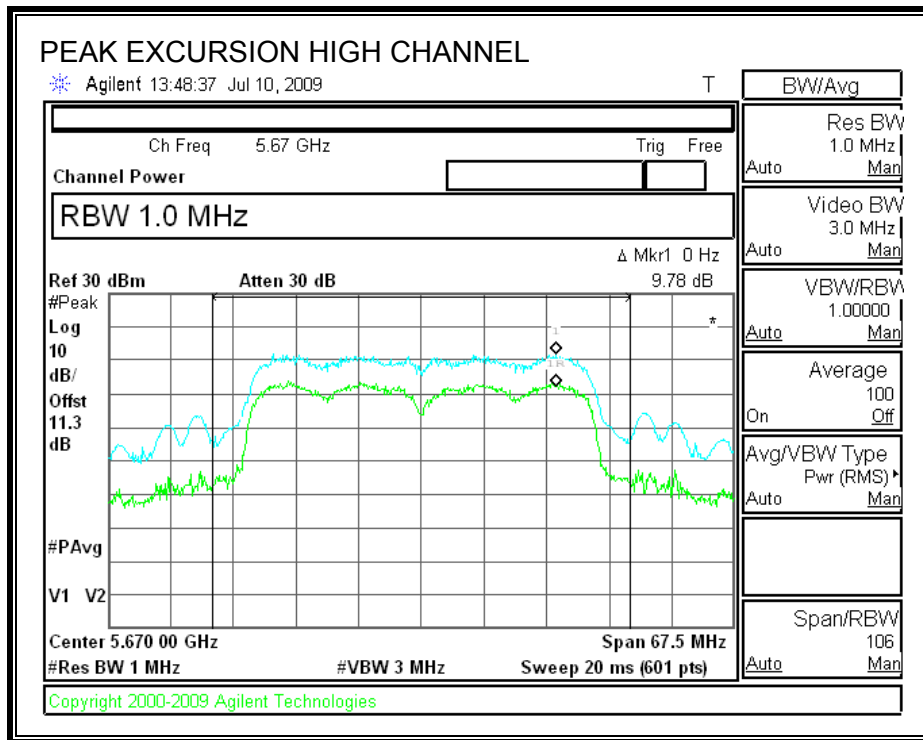

7.9.6. CONDUCTED SPURIOUS EMISSIONS

LIMITS

FCC §15.407 (b) (3)

IC RSS-210 A9.3 (3)

For transmitters operating in the 5.47-5.725 GHz band: all emissions outside of the 5.47-5.725 GHz band shall not exceed an EIRP of -27 dBm / MHz.

TEST PROCEDURE

Conducted RF measurements of the transmitter output are made to confirm that the EUT antenna port conducted emissions meet the specified limit and to identify any spurious signals that require further investigation or measurements on the radiated emissions site.

The transmitter output is connected to the spectrum analyzer. The resolution bandwidth is set to 1 MHz. The video bandwidth is set to 1 MHz. Peak detection measurements are compared to EIRP limit, adjusted for the maximum antenna gain.

Measurements are made over the 30 MHz to 40 GHz range with the transmitter set to the lowest, middle, and highest channels.

Preliminary tests on individual chains, and on all chains with a combiner, were performed. The worst-case configuration was with a combiner, therefore final test were performed with all chains feeding a combiner.

LOW CHANNEL SPURIOUS EMISSIONS

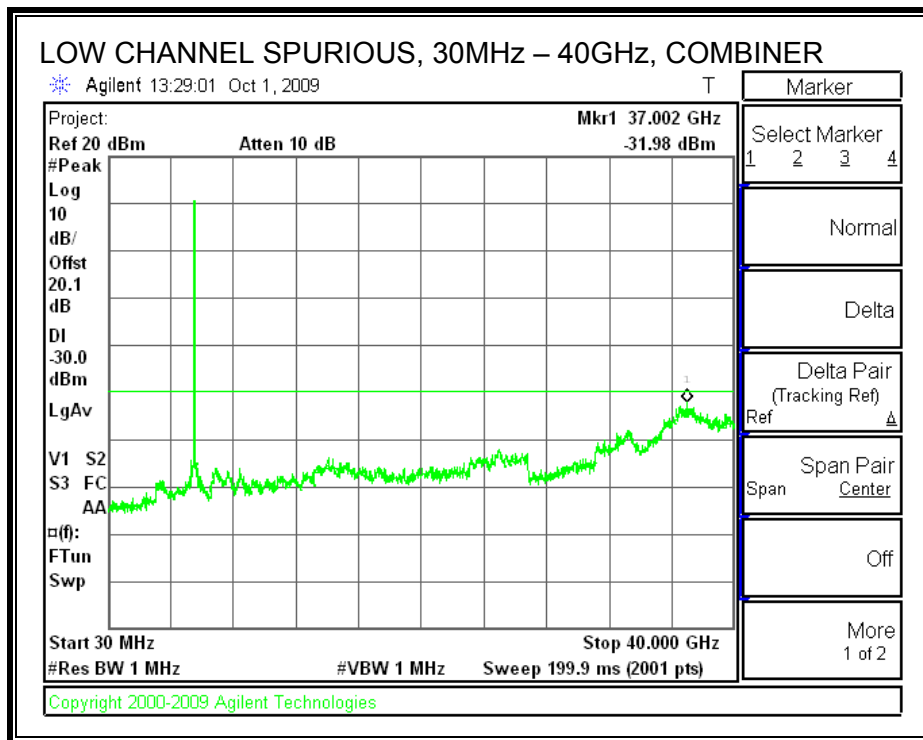

MID CHANNEL SPURIOUS EMISSIONS

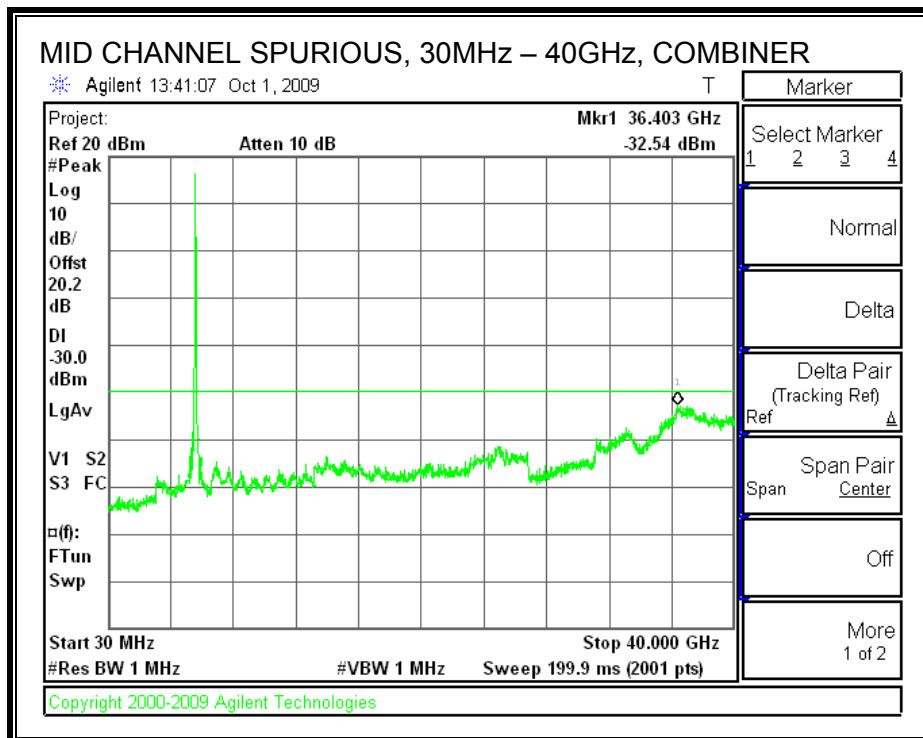

HIGH CHANNEL SPURIOUS EMISSIONS

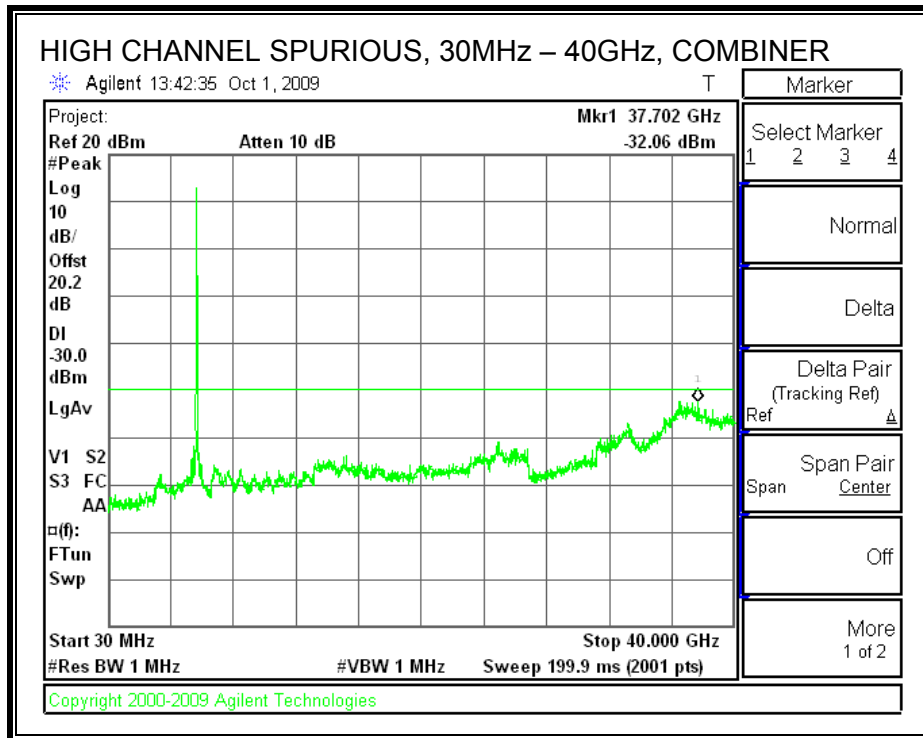

7.10. RECEIVER CONDUCTED SPURIOUS EMISSIONS

LIMITS

IC RSS-GEN 7.2.3.1

Antenna Conducted Measurement: Receiver spurious emissions at any discrete frequency shall not exceed 2 nanowatts (-57 dBm) in the band 30-1000 MHz, or 5 nanowatts (-53 dBm) above 1 GHz.

TEST PROCEDURE

IC RSS-GEN 4.10, Conducted Method

The receiver antenna port is connected to a spectrum analyzer.

The spectrum from 30 MHz to 18 GHz is investigated with the receiver set to the middle channel of each 5 GHz band.

Preliminary tests on individual chains, and on all chains with a combiner, were performed. The worst-case configuration was with a combiner, therefore final test were performed with all chains feeding a combiner.

RECEIVER SPURIOUS EMISSIONS IN THE 5.2 GHz BAND

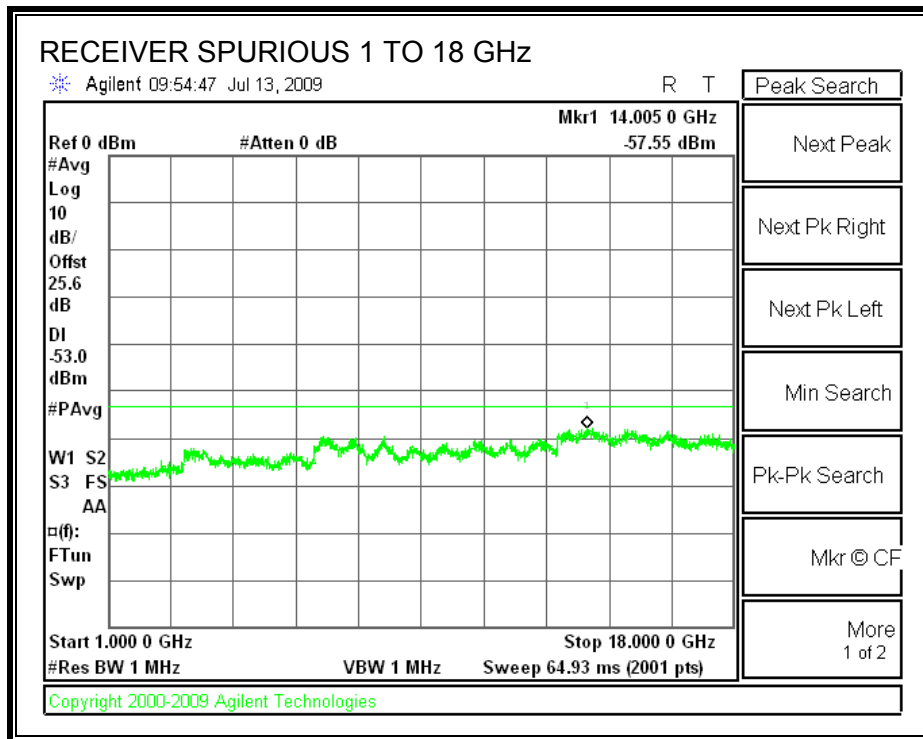
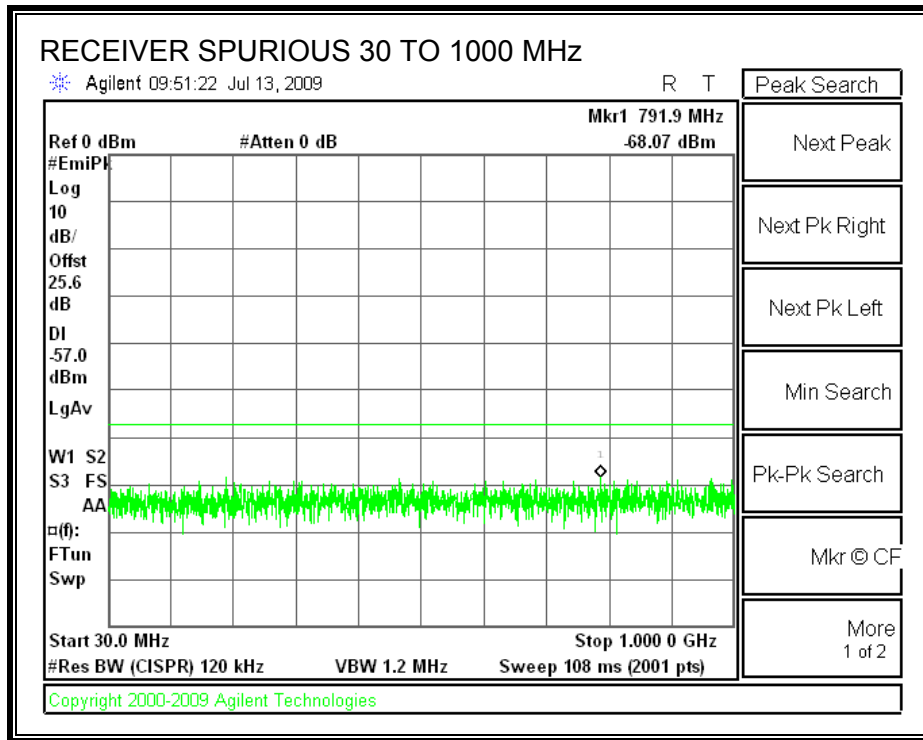

RECEIVER SPURIOUS EMISSIONS IN THE 5.3 GHz BAND

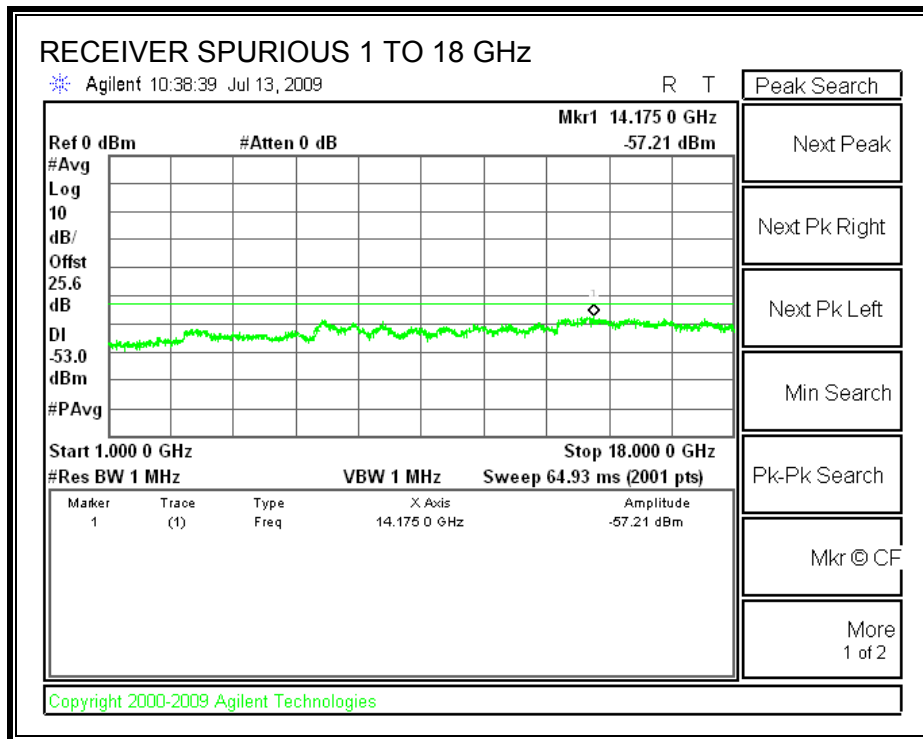
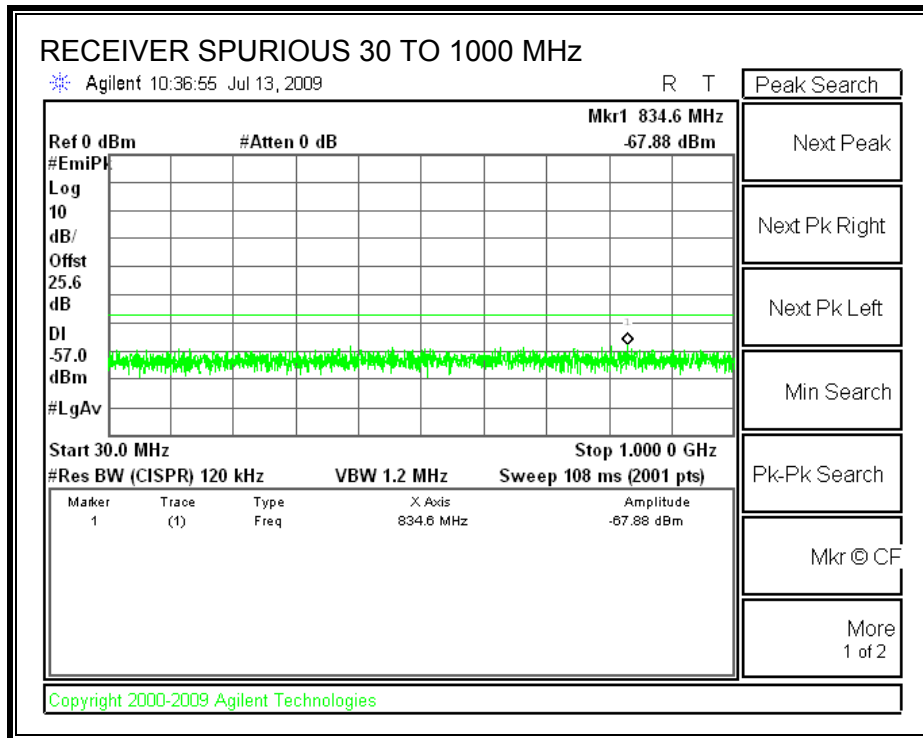

RECEIVER SPURIOUS EMISSIONS IN THE 5.5 GHz BAND

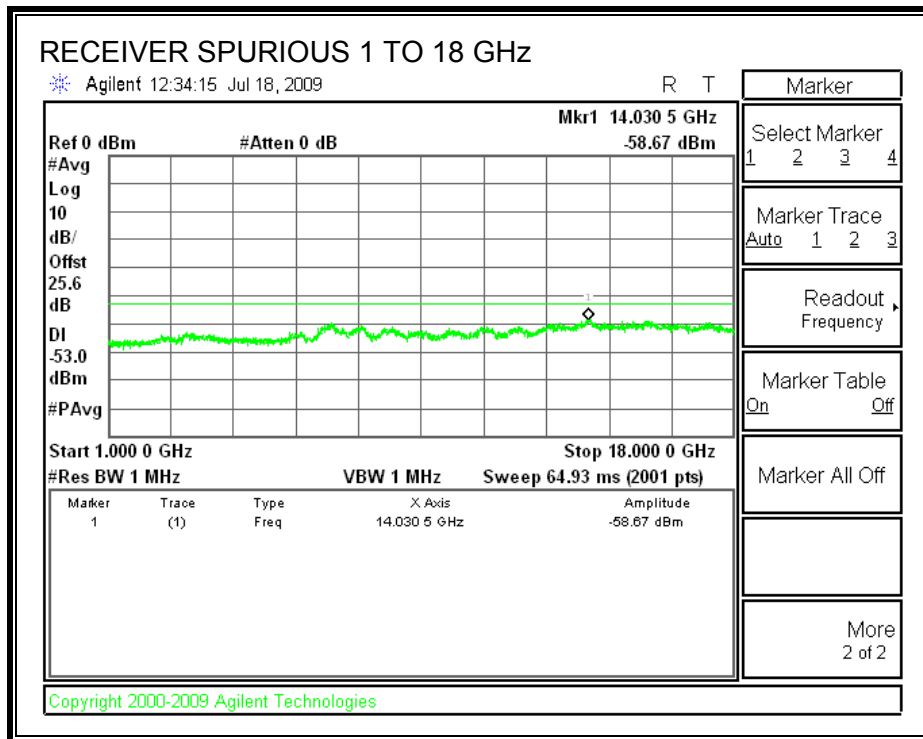
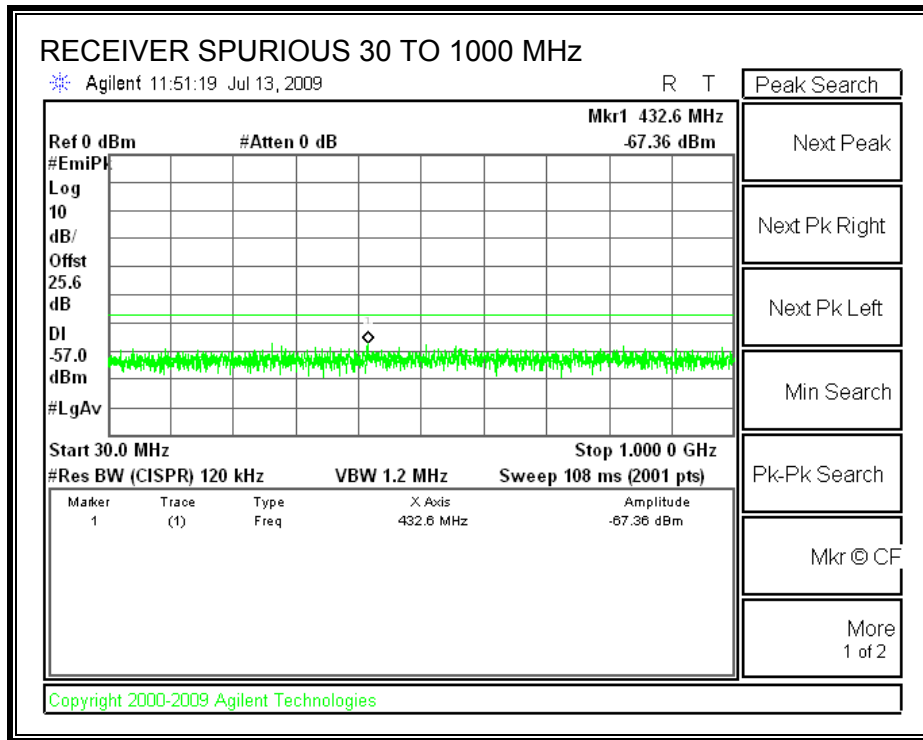

8. RADIATED TEST RESULTS

8.1. LIMITS AND PROCEDURE

LIMITS

FCC §15.205 and §15.209

IC RSS-210 Clause 2.6 (Transmitter)

IC RSS-GEN Clause 6 (Receiver)

Frequency Range (MHz)	Field Strength Limit (uV/m) at 3 m	Field Strength Limit (dBuV/m) at 3 m
30 - 88	100	40
88 - 216	150	43.5
216 - 960	200	46
Above 960	500	54

TEST PROCEDURE

The EUT is placed on a non-conducting table 80 cm above the ground plane. The antenna to EUT distance is 3 meters. The EUT is configured in accordance with ANSI C63.4. The EUT is set to transmit in a continuous mode.

For measurements below 1 GHz the resolution bandwidth is set to 100 kHz for peak detection measurements or 120 kHz for quasi-peak detection measurements. Peak detection is used unless otherwise noted as quasi-peak.

For measurements above 1 GHz the resolution bandwidth is set to 1 MHz, then the video bandwidth is set to 1 MHz for peak measurements and 10 Hz for average measurements.

The spectrum from 30 MHz to 40 GHz is investigated with the transmitter set to the lowest, middle, and highest channels in each applicable band.

The frequency range of interest is monitored at a fixed antenna height and EUT azimuth. The EUT is rotated through 360 degrees to maximize emissions received. The antenna is scanned from 1 to 4 meters above the ground plane to further maximize the emission. Measurements are made with the antenna polarized in both the vertical and the horizontal positions.

8.2. TRANSMITTER ABOVE 1 GHz

8.2.1. 802.11a MODE IN 5.2 GHz BAND

RESTRICTED BANDEDGE (LOW CHANNEL, HORIZONTAL)

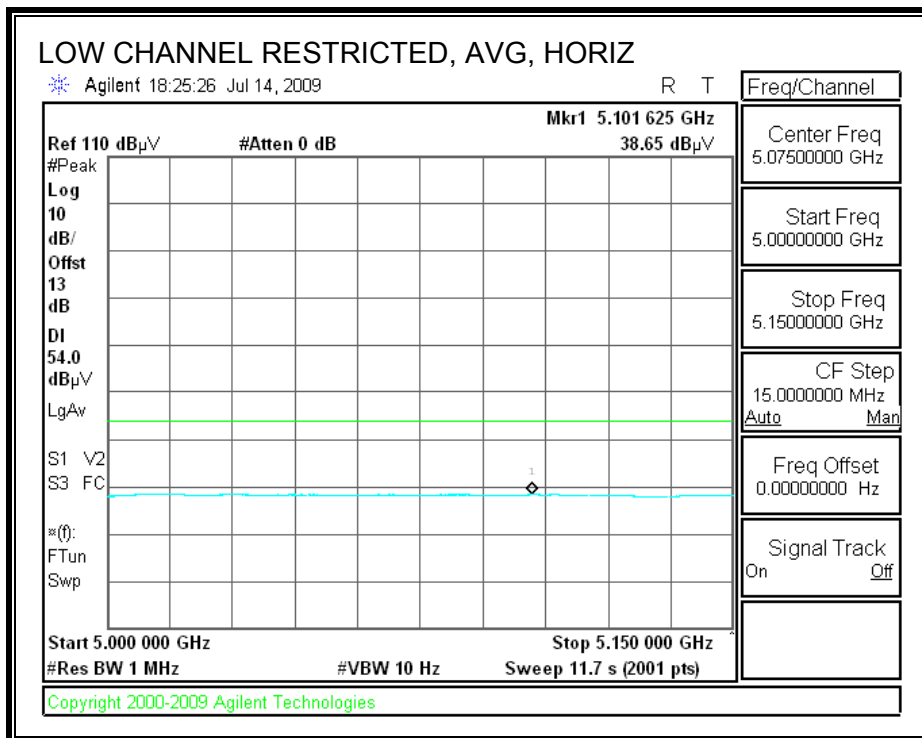
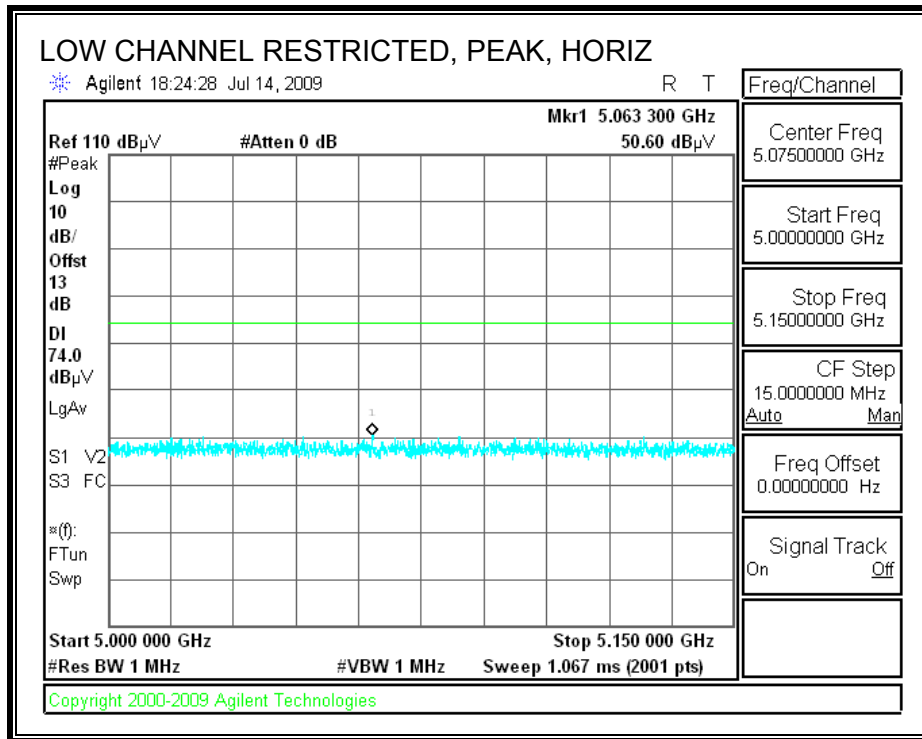

RESTRICTED BANDEDGE (LOW CHANNEL, VERTICAL)

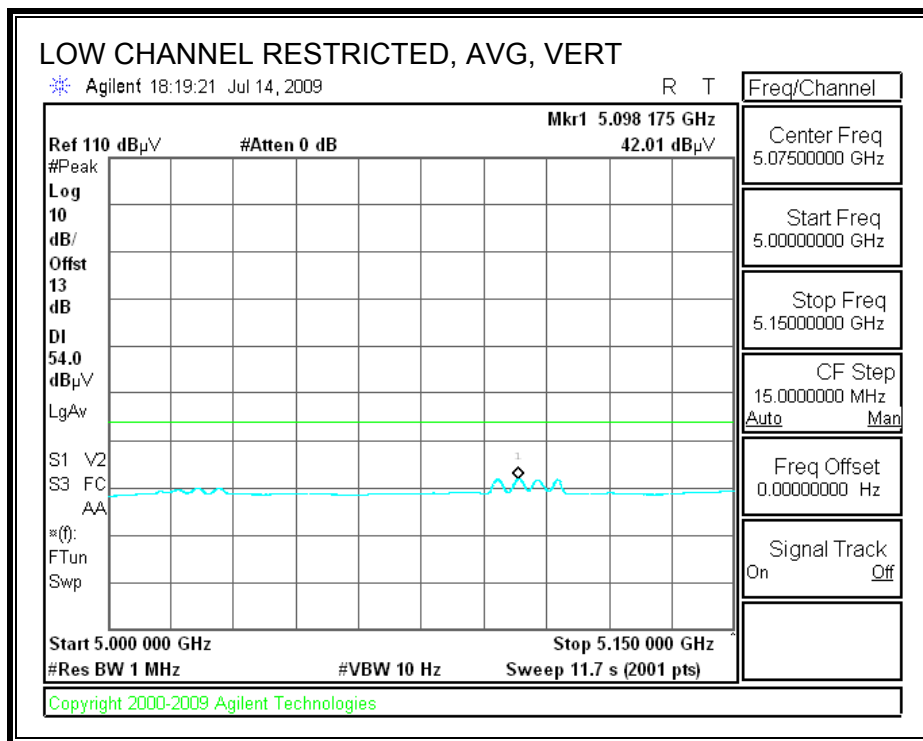
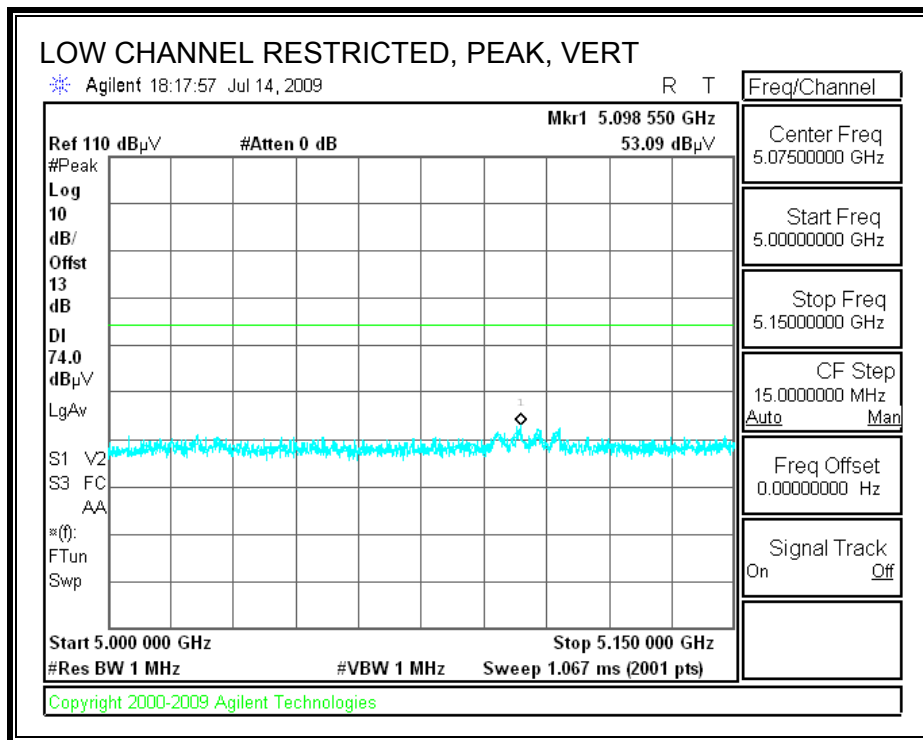

HARMONICS AND SPURIOUS EMISSIONS

High Frequency Measurement															
Compliance Certification Services, Fremont 5m Chamber															
Test Engr:		Thanh Nguyen													
Date:		07/14/09													
Project #:		09U12652													
Company:		QualComm													
EUT Description:		5000 Series PCI Card													
EUT M/N:		65-VN780-P2													
Test Target:		FCC 15.247/15.407													
Mode Oper:															
f	Measurement Frequency	Amp	Preamp Gain	Average Field Strength Limit											
Dist	Distance to Antenna	D Corr	Distance Correct to 3 meters	Peak Field Strength Limit											
Read	Analyzer Reading	Avg	Average Field Strength @ 3 m	Margin vs. Average Limit											
AF	Antenna Factor	Peak	Calculated Peak Field Strength	Margin vs. Peak Limit											
CL	Cable Loss	HPF	High Pass Filter												

f GHz	Dist (m)	Read dBuV	AF dB/m	CL dB	Amp dB	D Corr dB	Fltr dB	Corr. dBuV/m	Limit dBuV/m	Margin dB	Ant. Pol V/H	Det. P/A/QP	Ant.High cm	Table Angle Degree	Notes
Low Ch 5180MHz															
15.540	3.0	36.0	38.9	11.3	-34.8	0.0	10.0	61.4	74.0	-12.6	V	P	145.0	233.3	
15.540	3.0	23.7	38.9	11.3	-34.8	0.0	10.0	49.1	54.0	-4.9	V	A	145.0	233.3	
Mid Ch 5200MHz															
15.600	3.0	37.2	38.7	11.4	-34.8	0.0	10.0	62.5	74.0	-11.5	V	P	199.8	319.8	
15.600	3.0	24.3	38.7	11.4	-34.8	0.0	10.0	49.6	54.0	-4.4	V	A	199.8	319.8	
High Ch 5240MHz															
15.720	3.0	36.9	38.4	11.4	-34.7	0.0	10.0	62.0	74.0	-12.0	V	P	200.0	75.6	
15.720	3.0	24.2	38.4	11.4	-34.7	0.0	10.0	49.3	54.0	-4.7	V	A	200.0	75.6	
10.480	3.0	36.1	37.5	9.0	-36.7	0.0	10.0	55.8	74.0	-18.2	H	P	121.7	358.7	
10.480	3.0	23.8	37.5	9.0	-36.7	0.0	10.0	43.5	54.0	-10.5	H	A	121.7	358.7	
Rev. 4.1.2.7															
Note: No other emissions were detected above the system noise floor.															

8.2.2. 802.11n HT20 MODE IN 5.2 GHz BAND

RESTRICTED BANDEDGE (LOW CHANNEL, HORIZONTAL)

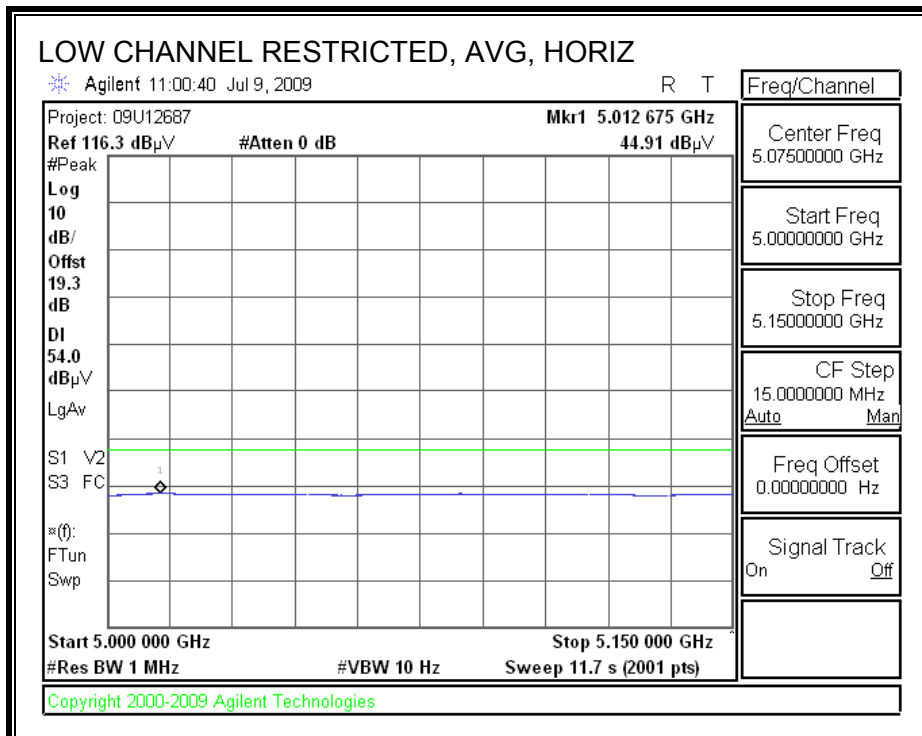
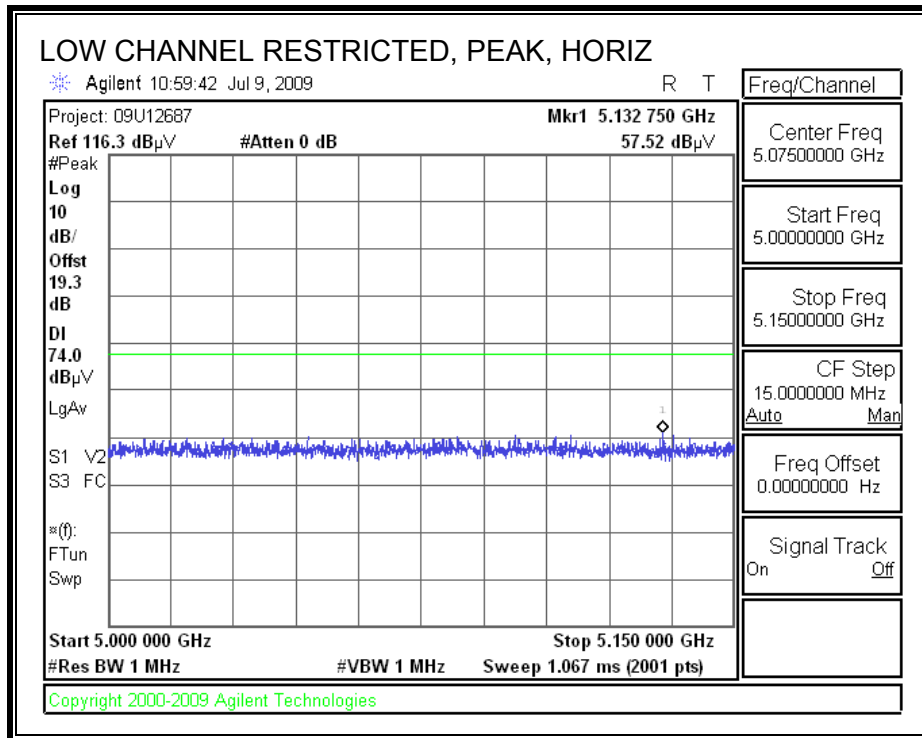

RESTRICTED BANDEDGE (LOW CHANNEL, VERTICAL)

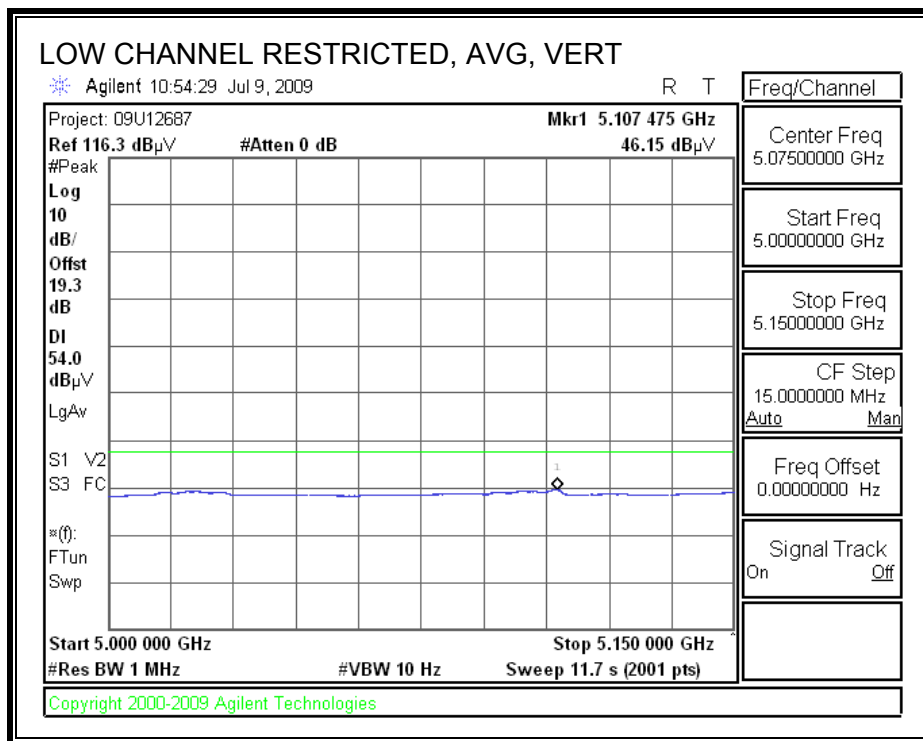
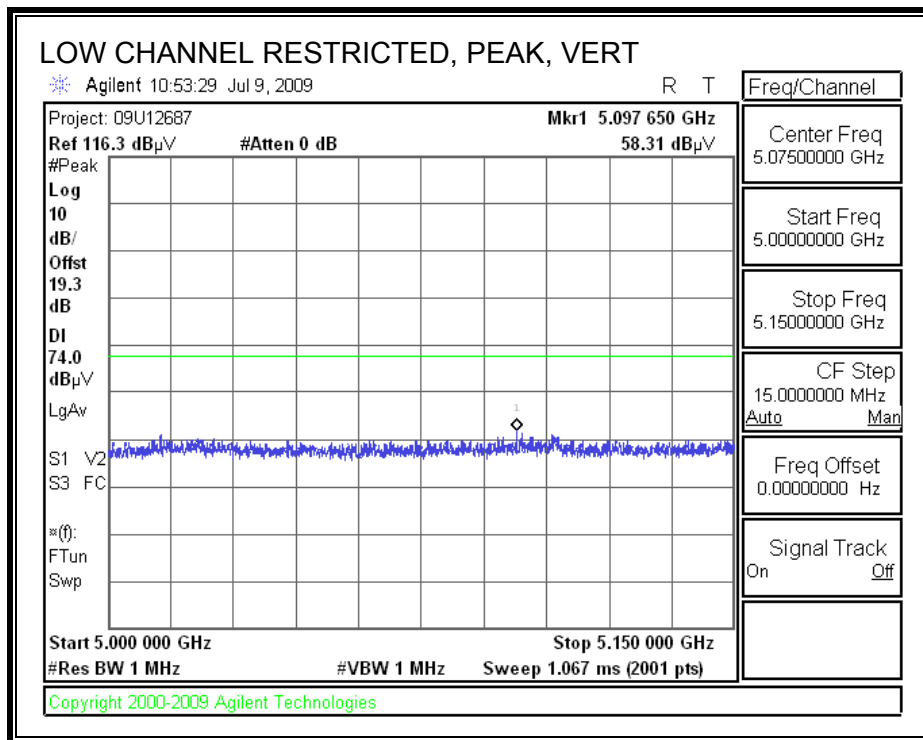

AUTHORIZED BANDEDGE (HIGH CHANNEL, VERTICAL)

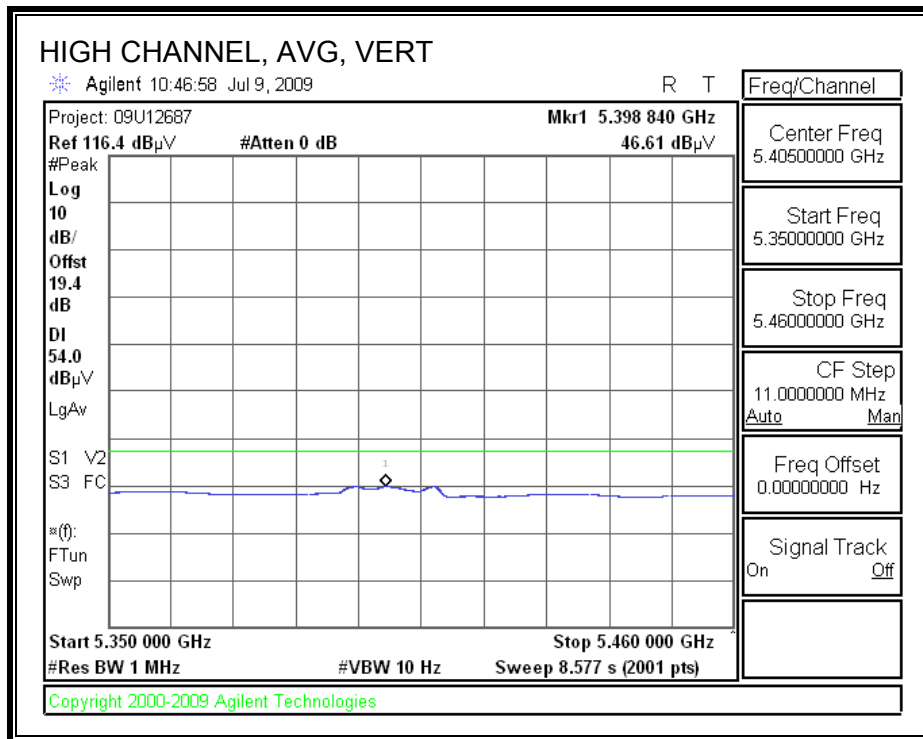
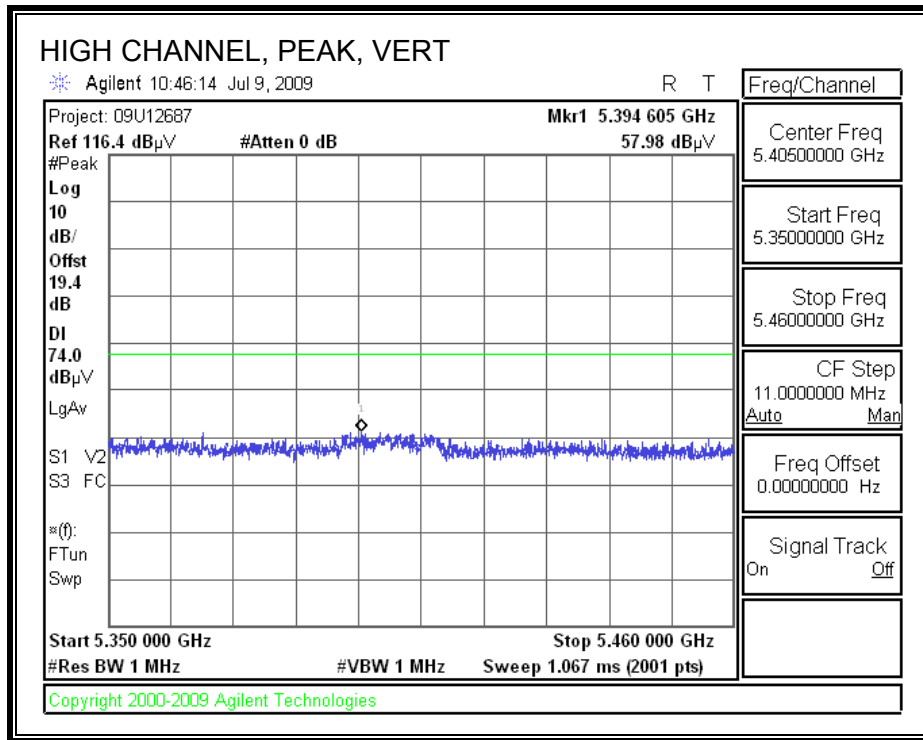

HARMONICS AND SPURIOUS EMISSIONS

High Frequency Measurement
 Compliance Certification Services, Fremont 5m Chamber

Company: Qualcomm
 Project #: 09U12687
 Date: 07/09/09
 Test Engineer: Doug Anderson
 Configuration: EUT w/Support Notebook PC
 Mode: Tx / HT20

Test Equipment:

Horn 1-18GHz	Pre-amplifier 1-26GHz	Pre-amplifier 26-40GHz	Horn > 18GHz	Limit
T73; S/N: 6717 @3m	T144 Miteq 3008A00931			FCC 15.205

Hi Frequency Cables

3' cable 22807700	12' cable 22807600	20' cable 22807500	HPF	Reject Filter	Peak Measurements RBW=VBW=1MHz
3' cable 22807700	12' cable 22807600	20' cable 22807500	HPF_7.6GHz		Average Measurements RBW=1MHz ; VBW=10Hz

f	Dist	Read Pk	Read Avg.	AF	CL	Amp	D Corr	Filtr	Peak	Avg	Pk Lim	Avg Lim	Pk Mar	Avg Mar	Notes
GHz	(m)	dBuV	dBuV	dB/m	dB	dB	dB	dB	dBuV/m	dBuV/m	dBuV/m	dBuV/m	dB	dB	(V/H)
Low Ch. 5180															
15.540	3.0	44.5	29.6	38.7	11.3	-34.8	0.0	0.7	60.4	45.5	74	54	-13.6	-8.5	H (Noise Floor)
15.540	3.0	44.5	29.6	38.7	11.3	-34.8	0.0	0.7	60.4	45.5	74	54	-13.6	-8.5	V (Noise Floor)
Mid Ch. 5200															
15.600	3.0	43.6	29.8	38.5	11.4	-34.8	0.0	0.7	59.4	45.7	74	54	-14.6	-8.3	H (Noise Floor)
15.600	3.0	43.4	29.9	38.5	11.4	-34.8	0.0	0.7	59.2	45.7	74	54	-14.8	-8.3	H (Noise Floor)
High Ch. 5240															
15.720	3.0	43.7	29.6	38.2	11.4	-34.7	0.0	0.7	59.3	45.3	74	54	-14.7	-8.7	H (Noise Floor)
15.720	3.0	43.6	29.7	38.2	11.4	-34.7	0.0	0.7	59.3	45.3	74	54	-14.7	-8.7	H (Noise Floor)

Rev. 11.10.08

f	Measurement Frequency	Amp	Preamp Gain	Avg Lim	Average Field Strength Limit
Dist	Distance to Antenna	D Corr	Distance Correct to 3 meters	Pk Lim	Peak Field Strength Limit
Read	Analyzer Reading	Avg	Average Field Strength @ 3 m	Avg Mar	Margin vs. Average Limit
AF	Antenna Factor	Peak	Calculated Peak Field Strength	Pk Mar	Margin vs. Peak Limit
CL	Cable Loss	HPF	High Pass Filter		

8.2.3. 802.11n HT40 MODE IN 5.2 GHz BAND

RESTRICTED BANDEDGE (LOW CHANNEL, HORIZONTAL)

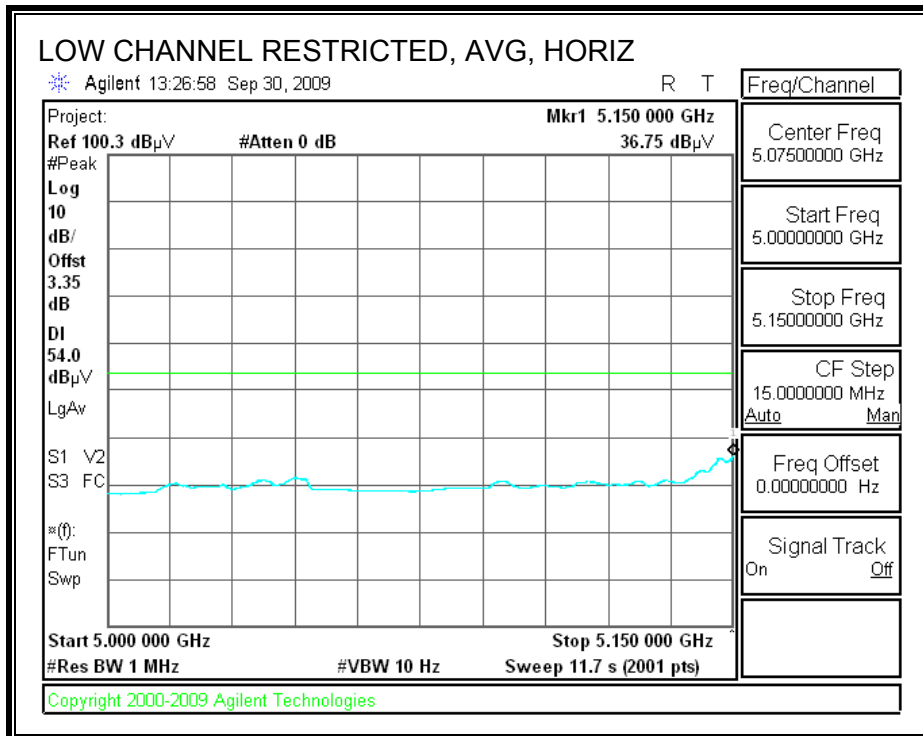
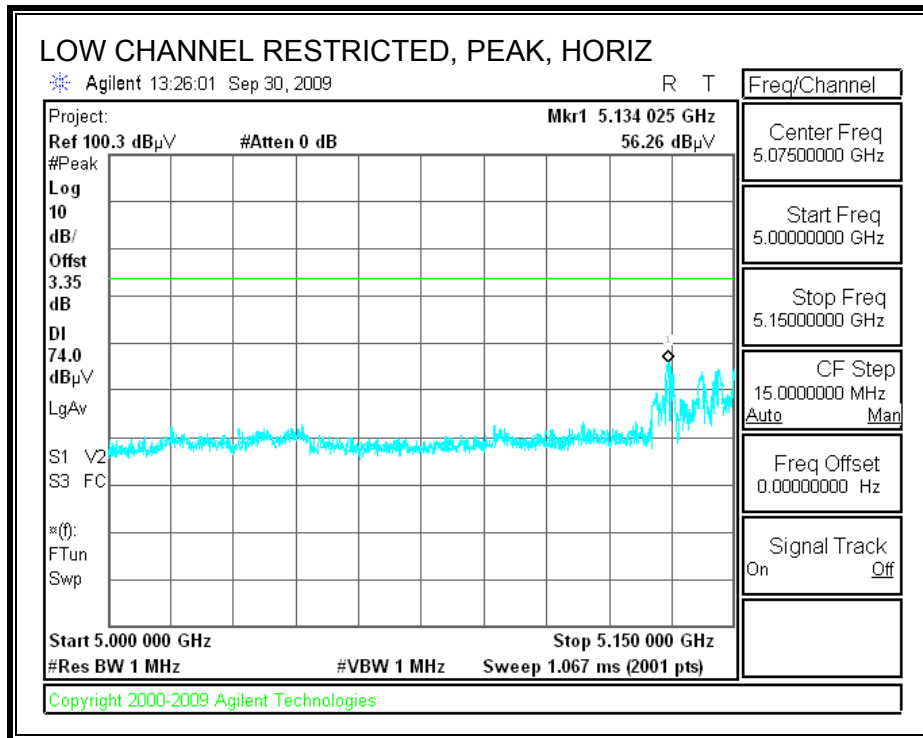

RESTRICTED BANDEDGE (LOW CHANNEL, VERTICAL)

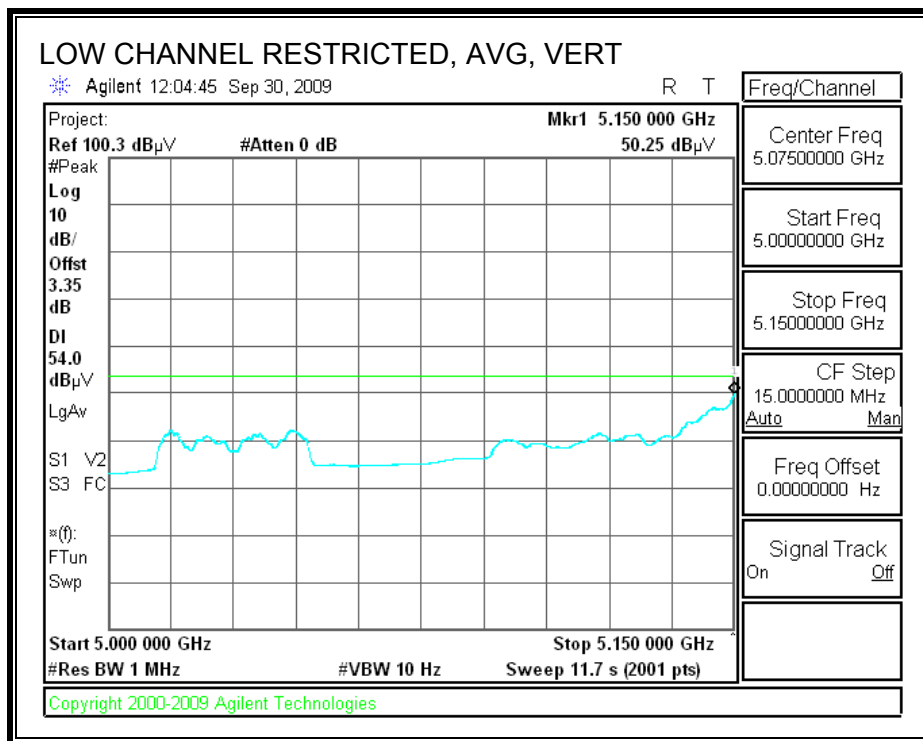
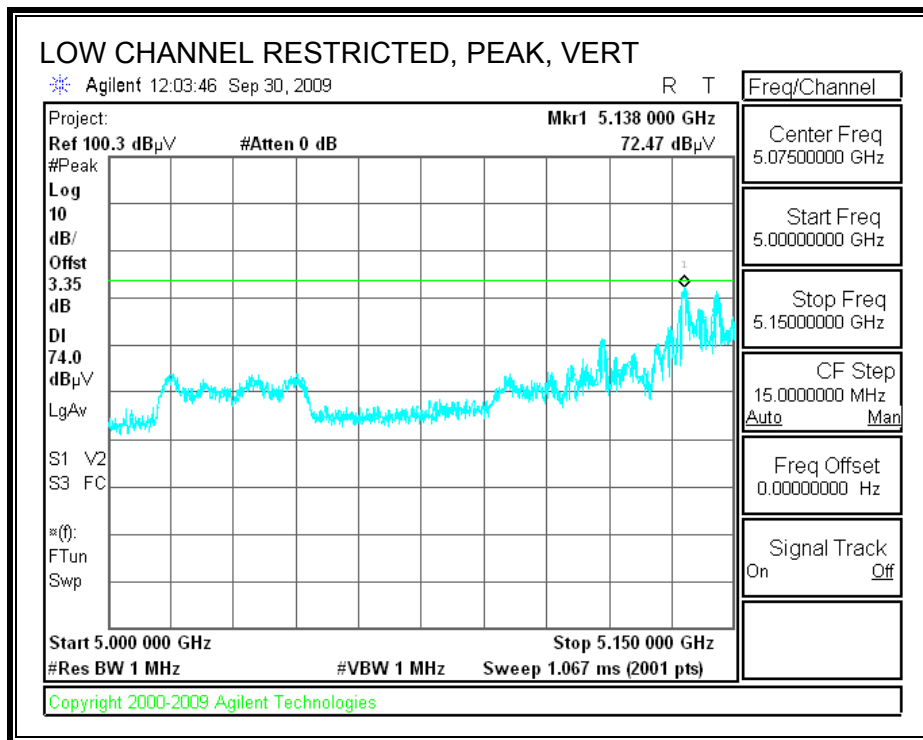

AUTHORIZED BANDEDGE (HIGH CHANNEL, VERTICAL)

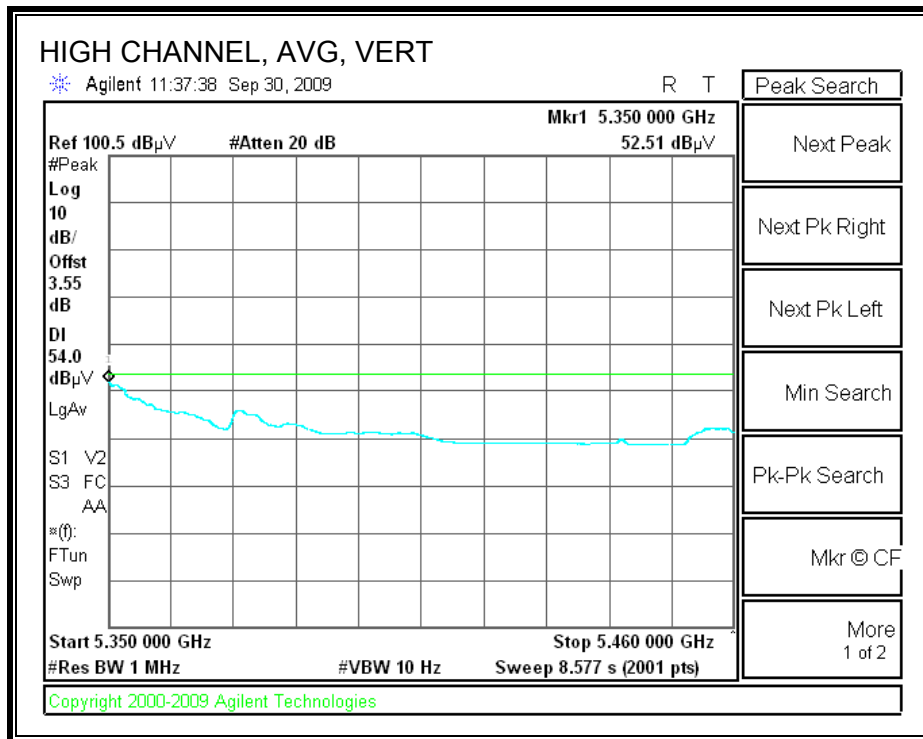
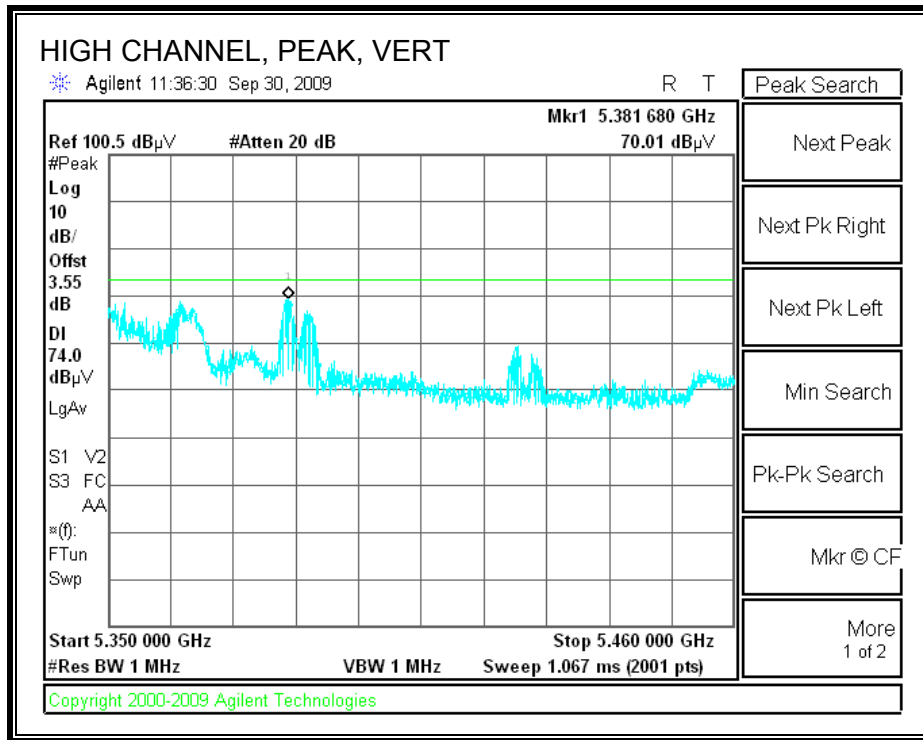

HARMONICS AND SPURIOUS EMISSIONS

High Frequency Measurement
 Compliance Certification Services, Fremont 5m Chamber

Company: Qualcomm
 Project #: 09U12687
 Date: 09/30/09
 Test Engineer: Thanh Nguyen
 Configuration: EUT w/Support Notebook PC
 Mode: Tx HT 40, MCS 31

Test Equipment:

Horn 1-18GHz	Pre-amplifier 1-26GHz	Pre-amplifier 26-40GHz	Horn > 18GHz	Limit
T73; S/N: 6717 @3m	T144 Miteq 3008A00931			FCC 15.205

Hi Frequency Cables

3' cable 22807700	12' cable 22807600	20' cable 22807500	HPF	Reject Filter	Peak Measurements RBW=VBW=1MHz
3' cable 22807700	12' cable 22807600	20' cable 22807500	HPF_7.6GHz		Average Measurements RBW=1MHz; VBW=10Hz

f GHz	Dist (m)	Read Pk dBuV	Read Avg. dBuV	AF dB/m	CL dB	Amp dB	D Corr dB	Filt dB	Peak dBuV/m	Avg dBuV/m	Pk Lim dBuV/m	Avg Lim dBuV/m	Pk Mar dB	Avg Mar dB	Notes (V/H)
Low Ch. 5190															
15.570	3.0	36.4	23.4	38.6	11.4	-34.8	0.0	0.7	52.3	39.3	74	54	-21.7	-14.7	V(Noise Floor)
15.570	3.0	34.8	23.4	38.6	11.4	-34.8	0.0	0.7	50.6	39.3	74	54	-23.4	-14.7	H(Noise Floor)
High Ch. 5230															
15.690	3.0	37.5	23.8	38.3	11.4	-34.7	0.0	0.7	53.1	39.5	74	54	-20.9	-14.5	H(Noise Floor)
15.690	3.0	38.4	23.8	38.3	11.4	-34.7	0.0	0.7	54.1	39.5	74	54	-19.9	-14.5	V(Noise Floor)

Rev. 11.10.08

f	Measurement Frequency	Amp	Preamp Gain	Avg Lim	Average Field Strength Limit
Dist	Distance to Antenna	D Corr	Distance Correct to 3 meters	Pk Lim	Peak Field Strength Limit
Read	Analyzer Reading	Avg	Average Field Strength @ 3 m	Avg Mar	Margin vs. Average Limit
AF	Antenna Factor	Peak	Calculated Peak Field Strength	Pk Mar	Margin vs. Peak Limit
CL	Cable Loss	HPF	High Pass Filter		

8.2.4. 802.11a MODE IN 5.3 GHz BAND

AUTHORIZED BANDEGE (HIGH CHANNEL, VERTICAL)

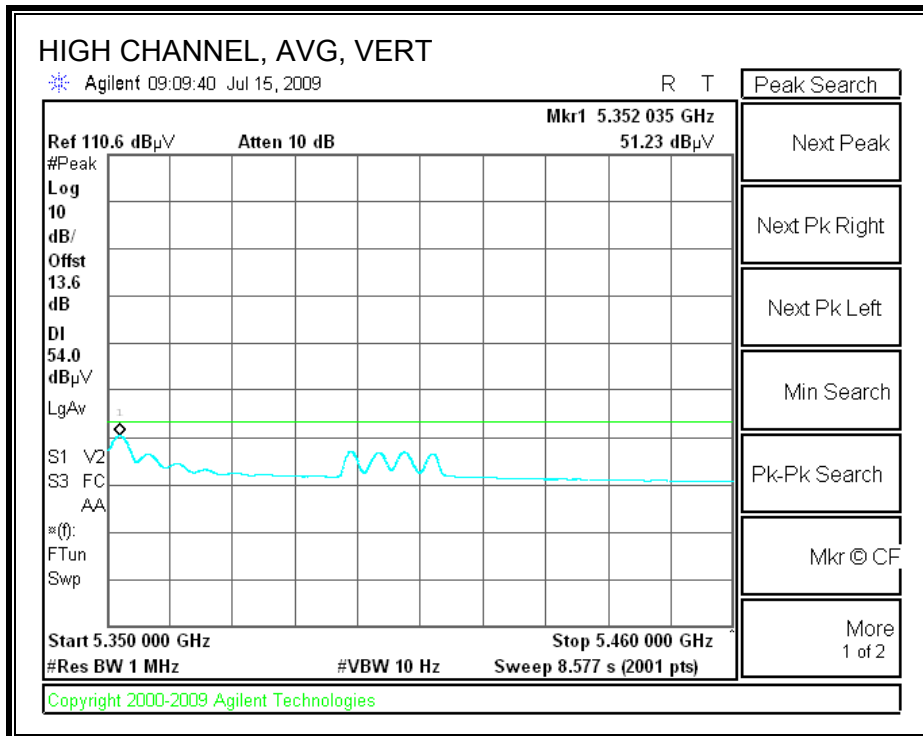
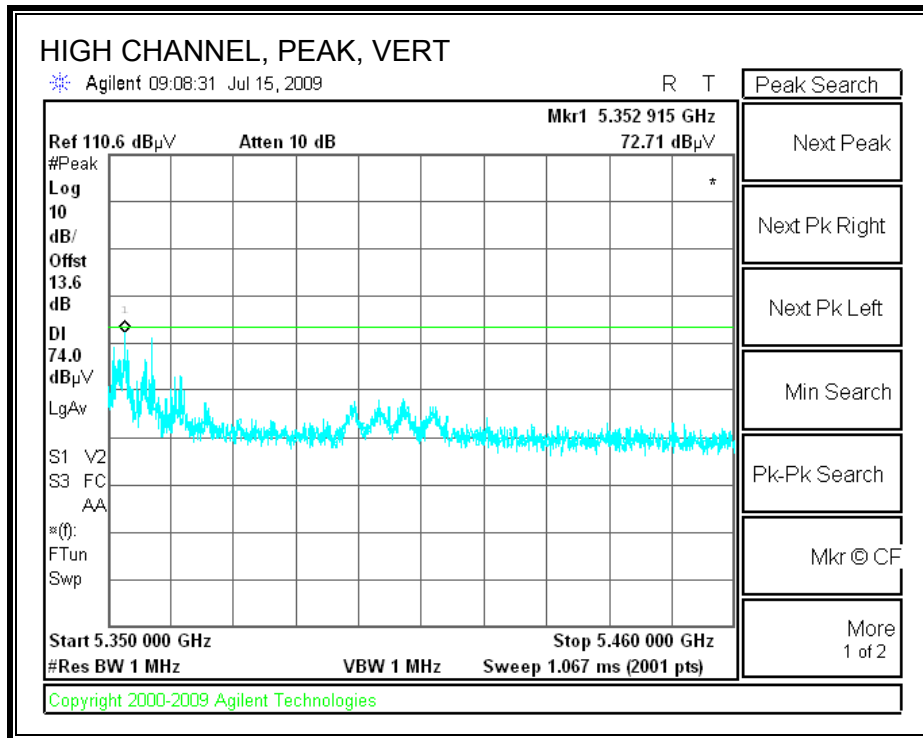

HARMONICS AND SPURIOUS EMISSIONS

High Frequency Measurement															
Compliance Certification Services, Fremont 5m Chamber															
Test Engr:		Thanh Nguyen													
Date:		07/15/09													
Project #:		09U12687													
Company:		QualComm													
EUT Description:		PCI card													
EUT M/N:		65-VN780-P2													
Test Target:		FCC15.247/15.407													
Mode Oper:		Tx a mode													
f	Measurement Frequency		Amp	Preamp Gain		Average Field Strength Limit									
Dist	Distance to Antenna		D Corr	Distance Correct to 3 meters		Peak Field Strength Limit									
Read	Analyzer Reading		Avg	Average Field Strength @ 3 m		Margin vs. Average Limit									
AF	Antenna Factor		Peak	Calculated Peak Field Strength		Margin vs. Peak Limit									
CL	Cable Loss		HPF	High Pass Filter											
f GHz	Dist (m)	Read dBuV	AF dB/m	CL dB	Amp dB	D Corr dB	Fltr dB	Corr. dBuV/m	Limit dBuV/m	Margin dB	Ant. Pol. V/H	Det. P/A/QP	Ant.High cm	Table Angle Degree	Notes
Low ch 5260MHz															
15.780	3.0	40.1	38.0	11.5	-34.6	0.0	0.7	55.6	74.0	-18.4	V	P	135.5	322.5	
15.780	3.0	27.9	38.0	11.5	-34.6	0.0	0.7	43.4	54.0	-10.6	V	A	135.5	322.5	
15.780	3.0	37.0	38.0	11.5	-34.6	0.0	0.7	52.6	74.0	-21.4	H	P	129.2	298.4	
15.780	3.0	25.0	38.0	11.5	-34.6	0.0	0.7	40.6	54.0	-13.4	H	A	129.2	298.4	
Mid ch 5300MHz															
10.600	3.0	37.6	37.7	9.0	-36.6	0.0	0.8	48.5	74.0	-25.5	V	P	100.0	200.0	
10.600	3.0	26.5	37.7	9.0	-36.6	0.0	0.8	37.4	54.0	-16.6	V	A	100.0	200.0	
15.900	3.0	39.7	37.7	11.5	-34.6	0.0	0.7	55.1	74.0	-18.9	V	P	101.8	225.7	
15.900	3.0	27.3	37.7	11.5	-34.6	0.0	0.7	42.6	54.0	-11.4	V	A	101.8	225.7	
10.600	3.0	37.8	37.7	9.0	-36.6	0.0	0.8	48.8	74.0	-25.2	H	P	149.4	297.9	
10.600	3.0	25.5	37.7	9.0	-36.6	0.0	0.8	36.5	54.0	-17.5	H	A	149.4	297.9	
15.900	3.0	38.8	37.7	11.5	-34.6	0.0	0.7	54.2	74.0	-19.8	H	P	149.4	297.9	
15.900	3.0	26.0	37.7	11.5	-34.6	0.0	0.7	41.3	54.0	-12.7	H	A	149.4	297.9	
High ch 5320MHz															
10.640	3.0	46.5	37.7	9.1	-36.6	0.0	0.8	57.4	74.0	-16.6	V	P	134.2	291.0	
10.640	3.0	35.0	37.7	9.1	-36.6	0.0	0.8	46.0	54.0	-8.0	V	A	134.2	291.0	
15.960	3.0	44.5	37.5	11.5	-34.5	0.0	0.7	59.8	74.0	-14.2	V	P	131.1	318.8	
15.960	3.0	31.8	37.5	11.5	-34.5	0.0	0.7	47.0	54.0	-7.0	V	A	131.1	318.8	
10.640	3.0	37.8	37.7	9.1	-36.6	0.0	0.8	48.8	74.0	-25.2	H	P	147.1	295.3	
10.640	3.0	28.4	37.7	9.1	-36.6	0.0	0.8	39.4	54.0	-14.6	H	A	147.1	295.3	
15.960	3.0	40.3	37.5	11.5	-34.5	0.0	0.7	55.6	74.0	-18.4	H	P	145.9	266.9	
15.960	3.0	27.6	37.5	11.5	-34.5	0.0	0.7	42.9	54.0	-11.1	H	A	145.9	266.9	
Rev. 4.1.2.7															
Note: No other emissions were detected above the system noise floor.															

8.2.5. 802.11n HT20 MODE IN 5.3 GHz BAND

RESTRICTED BANDEDGE (LOW CHANNEL, HORIZONTAL)

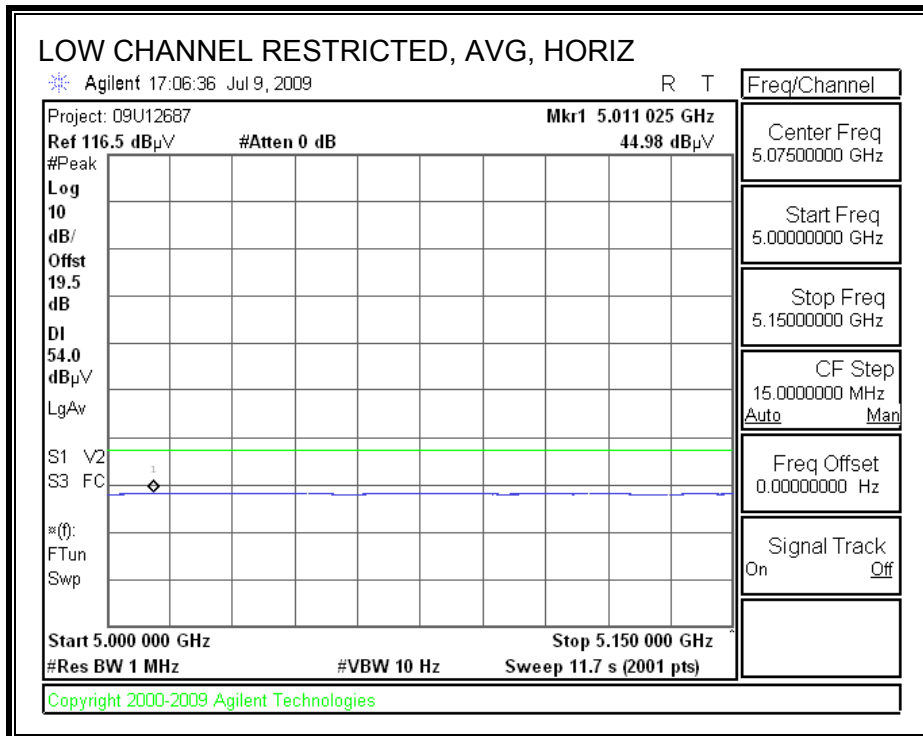
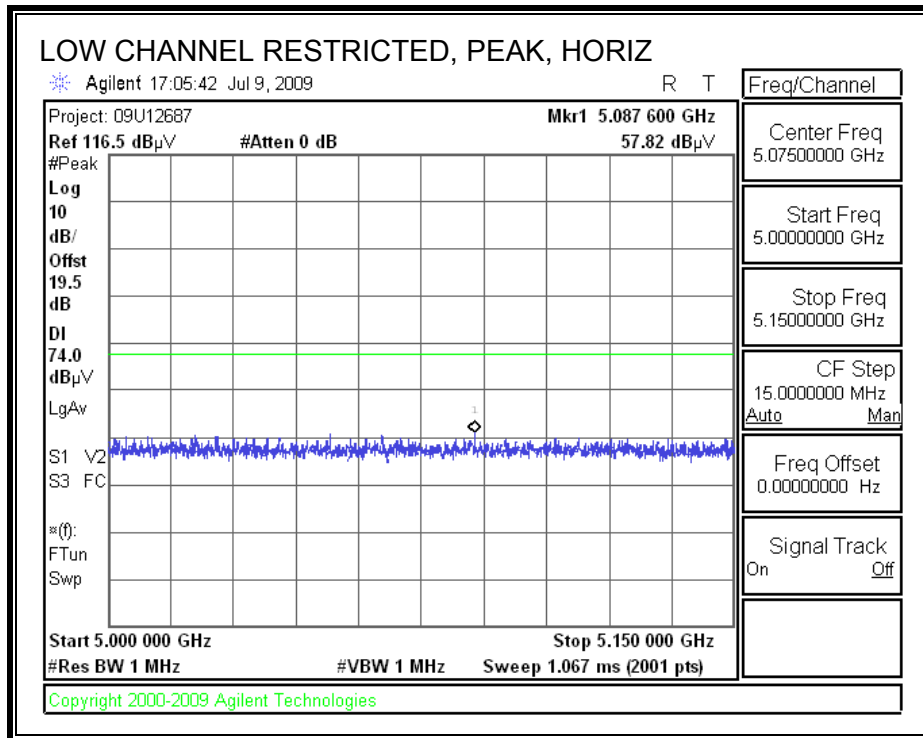

RESTRICTED BANDEDGE (LOW CHANNEL, VERTICAL)

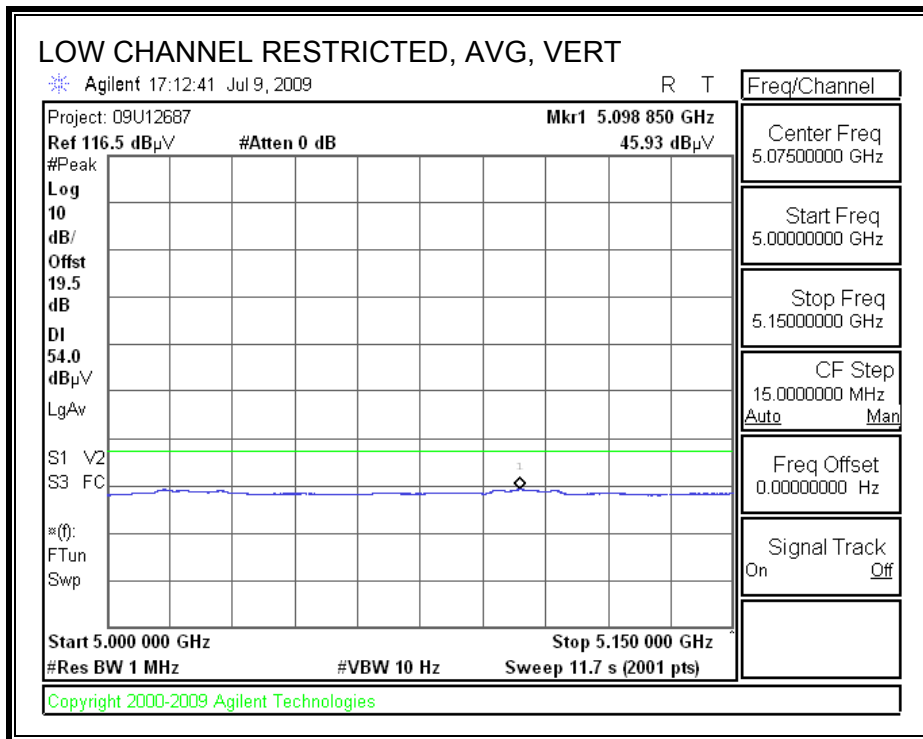
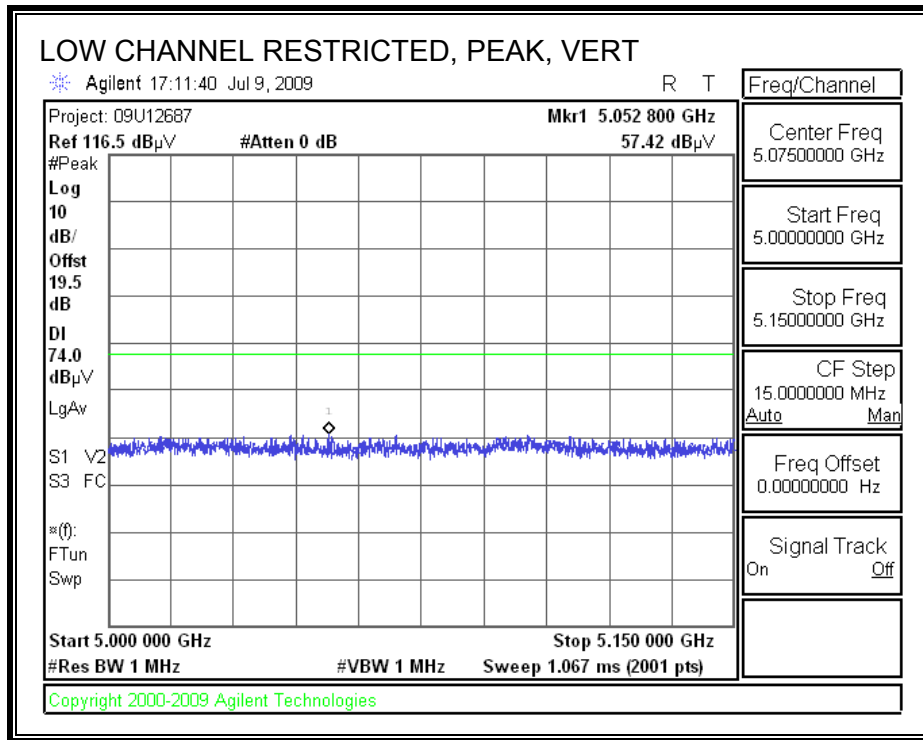

AUTHORIZED BANDEDGE (HIGH CHANNEL, VERTICAL)

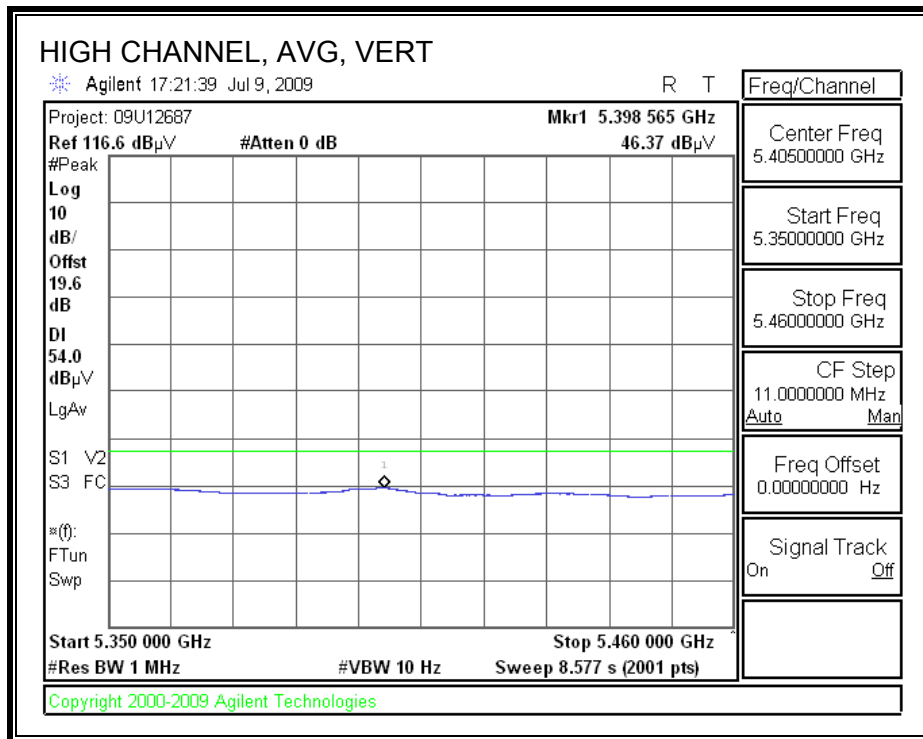
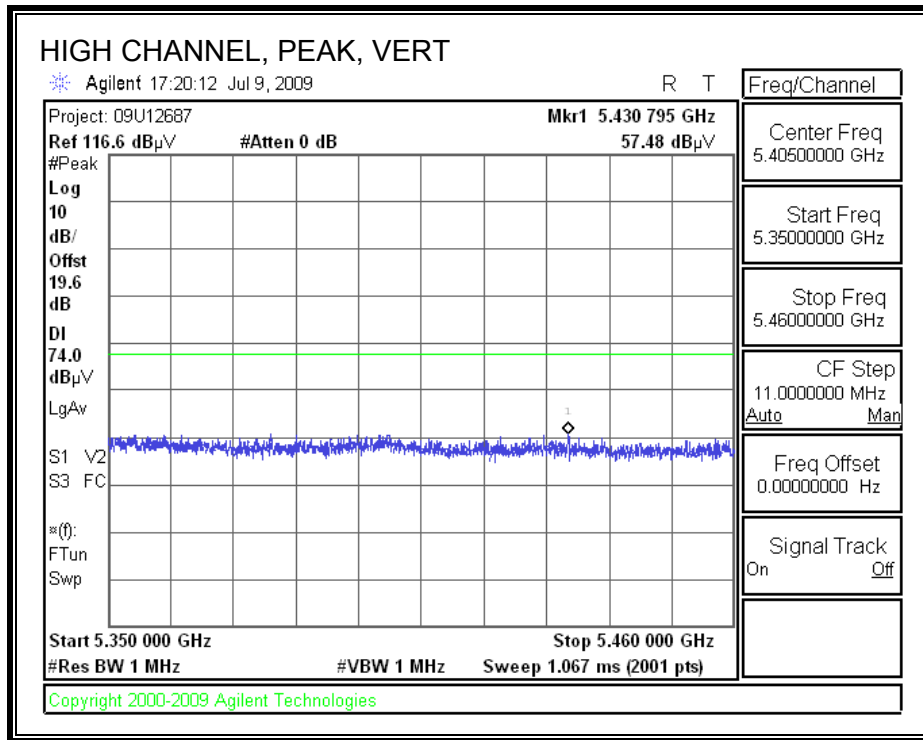

HARMONICS AND SPURIOUS EMISSIONS

High Frequency Measurement
 Compliance Certification Services, Fremont 5m Chamber

Company: Qualcomm
 Project #: 09U12687
 Date: 07/09/09
 Test Engineer: Doug Anderson
 Configuration: EUT w/Support Notebook PC
 Mode: Tx / HT20

Test Equipment:

Horn 1-18GHz	Pre-amplifier 1-26GHz	Pre-amplifier 26-40GHz	Horn > 18GHz	Limit
T73; S/N: 6717 @3m	T144 Miteq 3008A00931			FCC 15.205

Hi Frequency Cables

3' cable 22807700	12' cable 22807600	20' cable 22807500	HPF	Reject Filter	Peak Measurements RBW=VBW=1MHz
3' cable 22807700	12' cable 22807600	20' cable 22807500	HPF_7.6GHz		Average Measurements RBW=1MHz, VEW=10Hz

f GHz	Dist (m)	Read Pk dBuV	Read Avg. dBuV	AF dB/m	CL dB	Amp dB	D Corr dB	Filtr dB	Peak dBuV/m	Avg dBuV/m	Pk Lim dBuV/m	Avg Lim dBuV/m	Pk Mar dB	Avg Mar dB	Notes (V/H)
Low Ch. 5260 (Power = 11dBm)															
15.780	3.0	42.5	29.3	38.0	11.5	-34.6	0.0	0.7	58.1	44.9	74	54	-15.9	-9.1	H (Noise Floor)
15.780	3.0	42.4	29.4	38.0	11.5	-34.6	0.0	0.7	57.9	45.0	74	54	-16.1	-9.0	V (Noise Floor)
Mid Ch. 5300 (Power = 11dBm)															
10.600	3.0	43.2	32.5	37.7	9.0	-36.6	0.0	0.8	54.2	43.5	74	54	-19.8	-10.5	H
15.900	3.0	41.8	28.9	37.7	11.5	-34.6	0.0	0.7	57.2	44.3	74	54	-16.8	-9.7	H (Noise Floor)
10.600	3.0	46.1	38.8	37.7	9.0	-36.6	0.0	0.8	57.1	49.7	74	54	-16.9	-4.3	V
15.900	3.0	42.2	29.0	37.7	11.5	-34.6	0.0	0.7	57.5	44.3	74	54	-16.5	-9.7	V (Noise Floor)
High Ch. 5320 (Power = 11dBm)															
10.640	3.0	43.2	32.9	37.7	9.1	-36.6	0.0	0.8	54.2	43.8	74	54	-19.8	-10.2	H
15.960	3.0	41.7	28.9	37.5	11.5	-34.5	0.0	0.7	57.0	44.2	74	54	-17.0	-9.8	H (Noise Floor)
10.640	3.0	45.7	38.2	37.7	9.1	-36.6	0.0	0.8	56.7	49.2	74	54	-17.3	-4.8	V
15.960	3.0	41.5	28.9	37.5	11.5	-34.5	0.0	0.7	56.8	44.2	74	54	-17.2	-9.8	V (Noise Floor)

Rev. 11.10.08

f	Measurement Frequency	Amp	Preamp Gain	Avg Lim	Average Field Strength Limit
Dist	Distance to Antenna	D Corr	Distance Correct to 3 meters	Pk Lim	Peak Field Strength Limit
Read	Analyzer Reading	Avg	Average Field Strength @ 3 m	Avg Mar	Margin vs. Average Limit
AF	Antenna Factor	Peak	Calculated Peak Field Strength	Pk Mar	Margin vs. Peak Limit
CL	Cable Loss	HPF	High Pass Filter		

8.2.6. 802.11n HT40 MODE IN 5.3 GHz BAND

AUTHORIZED BANDEDGE (HIGH CHANNEL, VERTICAL)

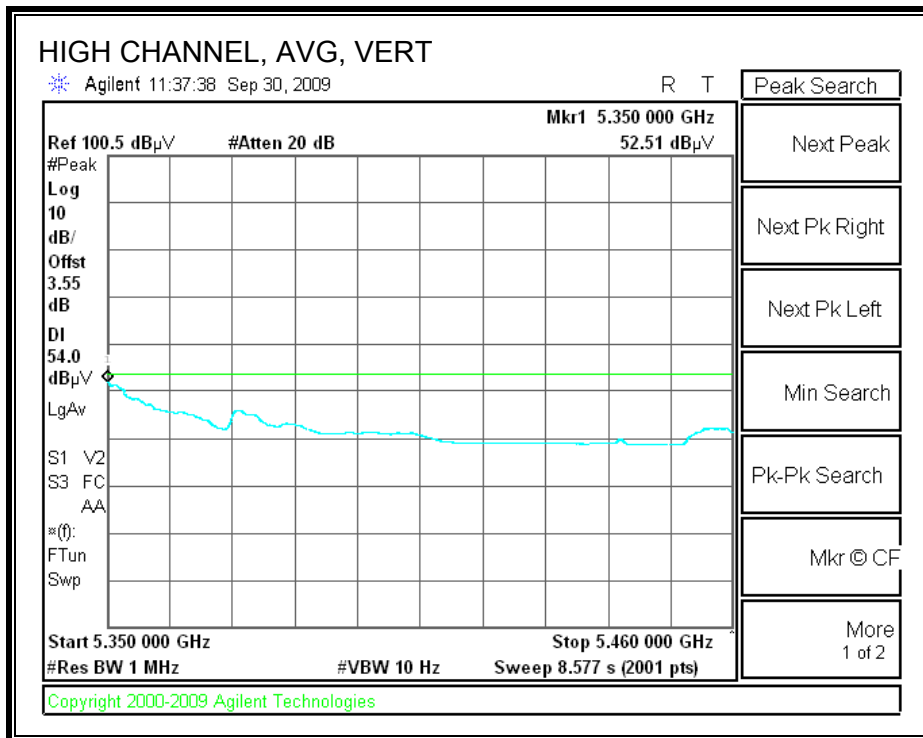
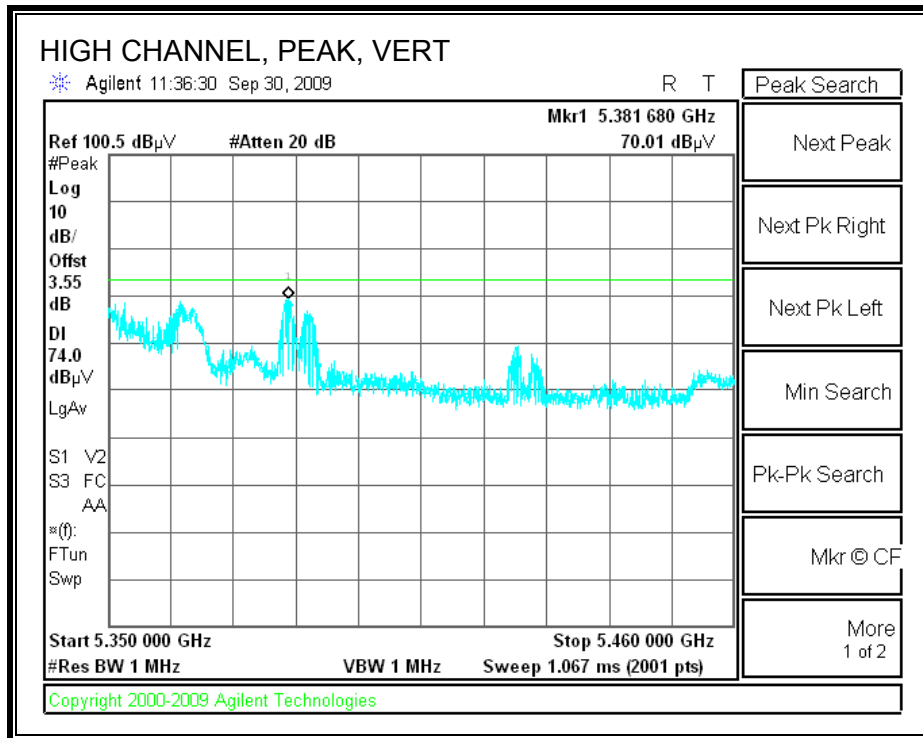

HARMONICS AND SPURIOUS EMISSIONS

High Frequency Measurement
 Compliance Certification Services, Fremont 5m Chamber

Company: Qualcomm
 Project #: 09U12687
 Date: 09/30/09
 Test Engineer: Thanh Ngyuen
 Configuration: EUT w/Support Notebook PC
 Mode: Tx / HT40, MCS 31

Test Equipment:

Horn 1-18GHz	Pre-amplifer 1-26GHz	Pre-amplifer 26-40GHz	Horn > 18GHz	Limit
T73; S/N: 6717 @3m	T144 Miteq 3008A00931			FCC 15.205

Hi Frequency Cables

3' cable 22807700	12' cable 22807600	20' cable 22807500	HPF	Reject Filter	Peak Measurements RBW=VBW=1MHz
3' cable 22807700	12' cable 22807600	20' cable 22807500	HPF_7.6GHz		Average Measurements RBW=1MHz ; VBW=10Hz

f GHz	Dist (m)	Read Pk dBuV	Read Avg. dBuV	AF dB/m	CL dB	Amp dB	D Corr dB	Filt dB	Peak dBuV/m	Avg dBuV/m	Pk Lim dBuV/m	Avg Lim dBuV/m	Pk Mar dB	Avg Mar dB	Notes (V/H)
Low Ch. 5270															
15.810	3.0	44.2	33.8	37.9	11.5	-34.6	0.0	0.7	59.7	49.3	74	54	-14.3	-4.7	H
15.810	3.0	46.3	37.2	37.9	11.5	-34.6	0.0	0.7	61.8	52.7	74	54	-12.2	-1.3	V
High Ch. 5310															
10.620	3.0	43.2	32.6	37.7	9.0	-36.6	0.0	0.8	54.2	43.5	74	54	-19.8	-10.5	H
15.930	3.0	42.6	28.9	37.6	11.5	-34.5	0.0	0.7	57.9	44.2	74	54	-16.1	-9.8	H
10.620	3.0	46.2	39.4	37.7	9.0	-36.6	0.0	0.8	57.2	50.4	74	54	-16.8	-3.6	V
15.930	3.0	42.9	29.0	37.6	11.5	-34.5	0.0	0.7	58.2	44.3	74	54	-15.8	-9.7	V

Rev. 11.10.08

f	Measurement Frequency	Amp	Preamp Gain	Avg Lim	Average Field Strength Limit
Dist	Distance to Antenna	D Corr	Distance Correct to 3 meters	Pk Lim	Peak Field Strength Limit
Read	Analyzer Reading	Avg	Average Field Strength @ 3 m	Avg Mar	Margin vs. Average Limit
AF	Antenna Factor	Peak	Calculated Peak Field Strength	Pk Mar	Margin vs. Peak Limit
CL	Cable Loss	HPF	High Pass Filter		

8.2.7. 802.11a MODE IN THE 5.6 GHz BAND

RESTRICTED BANDEDGE (LOW CHANNEL, HORIZONTAL)

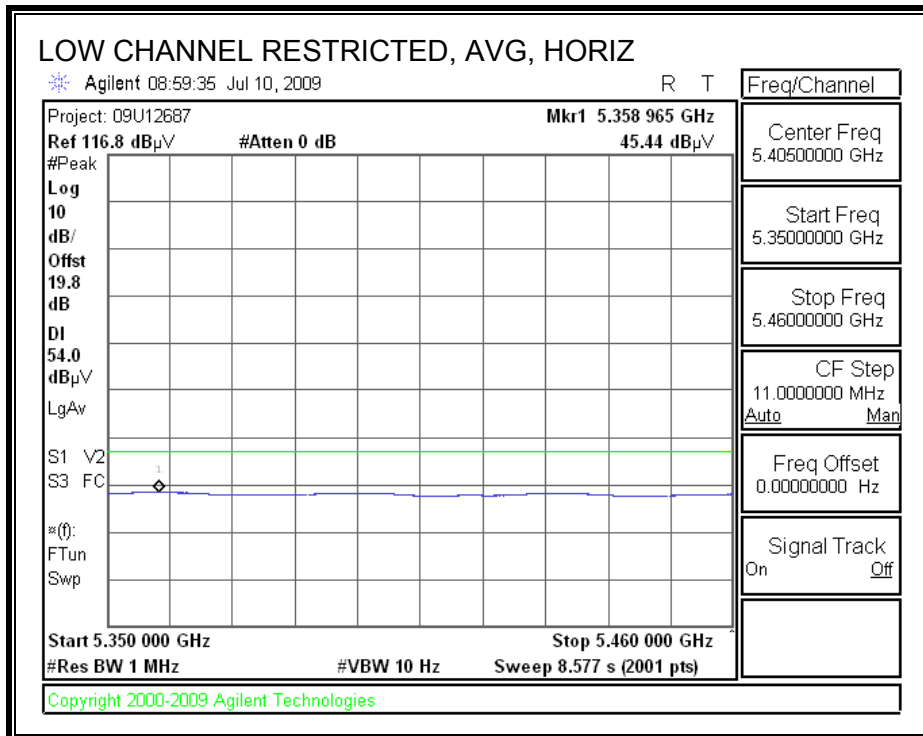
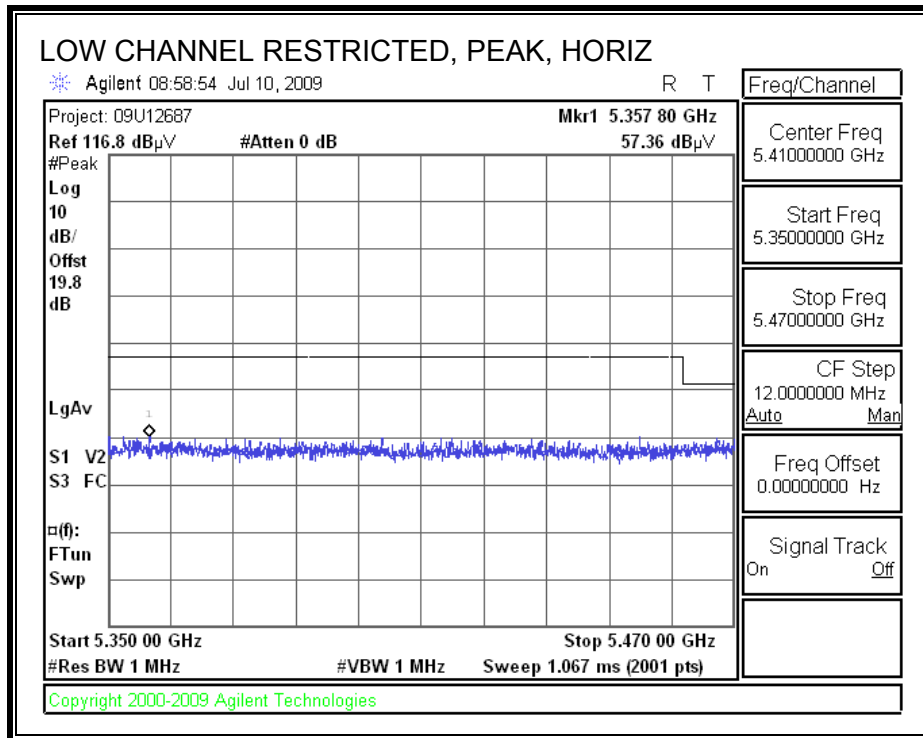

RESTRICTED BANDEDGE (LOW CHANNEL, VERTICAL)

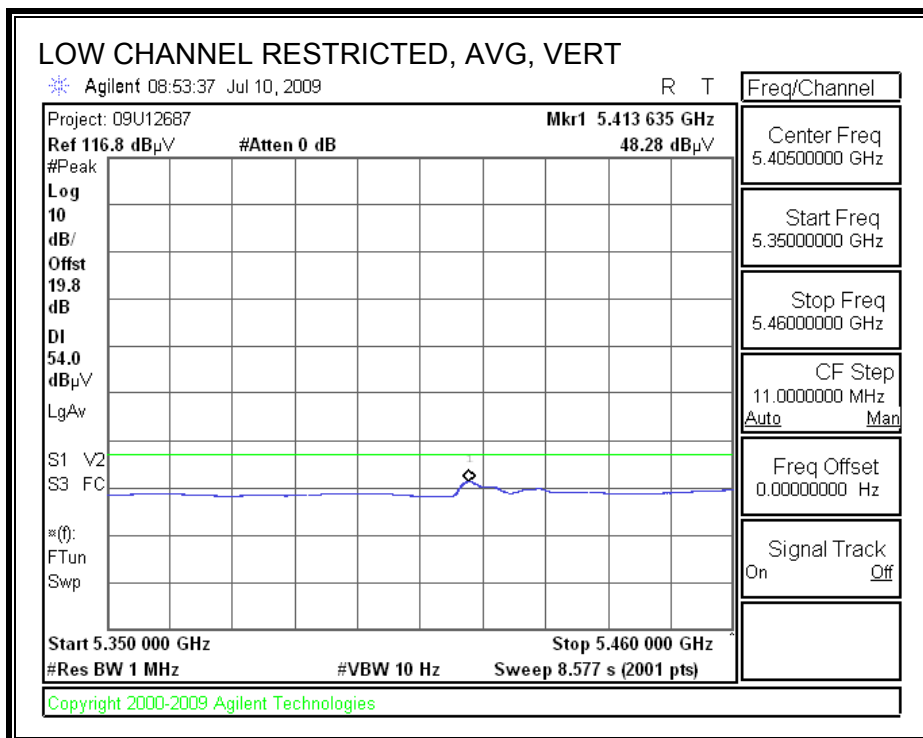
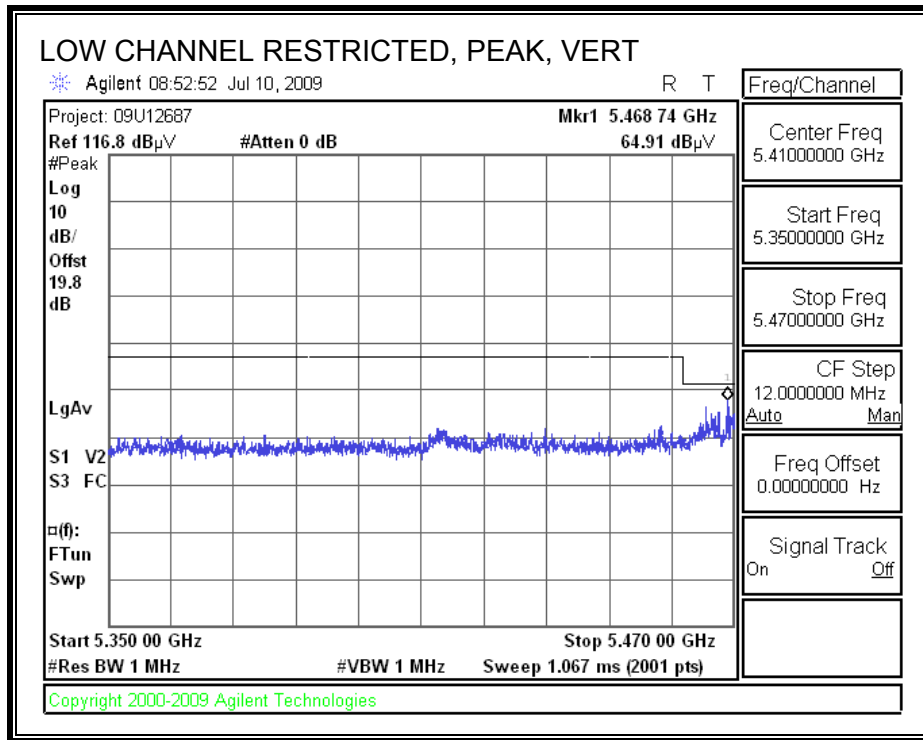

AUTHORIZED BANDEDGE (HIGH CHANNEL, VERTICAL)

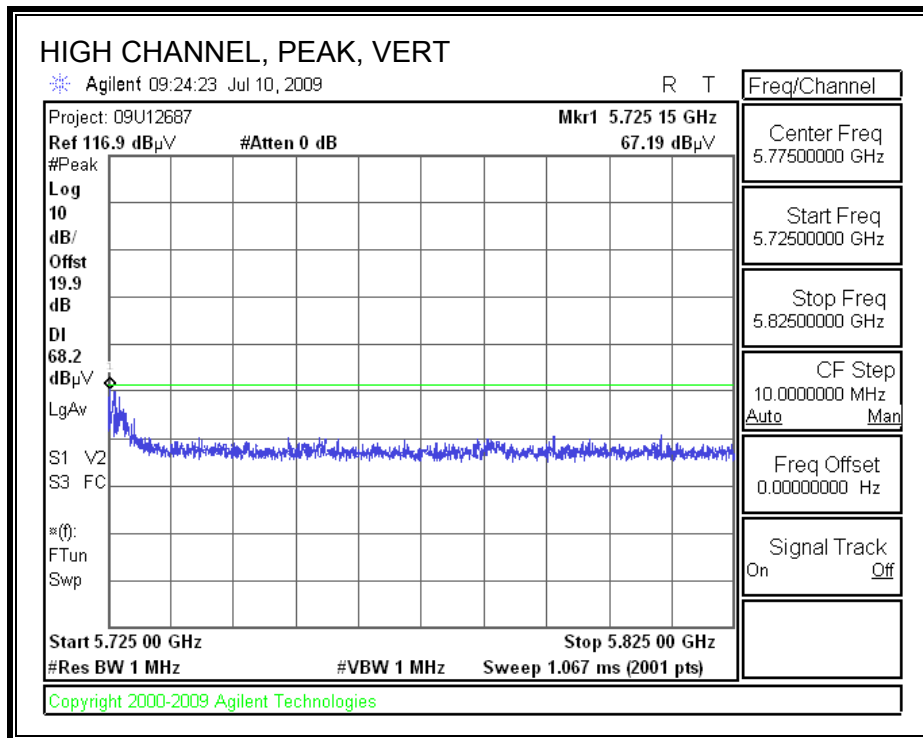

HARMONICS AND SPURIOUS EMISSIONS

High Frequency Measurement
 Compliance Certification Services, Fremont 5m Chamber

Company: Qualcomm
 Project #: 09U12687
 Date: 07/08/09
 Test Engineer: Doug Anderson
 Configuration: EUT w/Support Notebook PC
 Mode: Tx / 802.11a

Test Equipment:

Horn 1-18GHz	Pre-amplifier 1-26GHz	Pre-amplifier 26-40GHz	Horn > 18GHz	Limit
T73; S/N: 6717 @3m	T144 Miteq 3008A00931			FCC 15.205

Hi Frequency Cables

3' cable 22807700	12' cable 22807600	20' cable 22807500	HPF	Reject Filter	Peak Measurements RBW=VBW=1MHz
3' cable 22807700	12' cable 22807600	20' cable 22807500	HPF_7.6GHz		Average Measurements RBW=1MHz ; VBW=10Hz

f GHz	Dist (m)	Read Pk dBuV	Read Avg. dBuV	AF dB/m	CL dB	Amp dB	D Corr dB	Filtr dB	Peak dBuV/m	Avg dBuV/m	Pk Lim dBuV/m	Avg Lim dBuV/m	Pk Mar dB	Avg Mar dB	Notes (V/H)
Low Ch. 5500															
11.000	3.0	40.6	27.1	37.9	9.2	-36.3	0.0	0.7	52.2	38.7	74	54	-21.8	-15.3	V (Noise Floor)
11.000	3.0	39.6	27.5	37.9	9.2	-36.3	0.0	0.7	51.2	39.1	74	54	-22.8	-14.9	H (Noise Floor)
Mid. Ch. 5600															
11.200	3.0	44.7	35.9	38.1	9.3	-36.1	0.0	0.7	56.7	47.9	74	54	-17.3	-6.1	V
11.200	3.0	41.8	30.2	38.1	9.3	-36.1	0.0	0.7	53.9	42.3	74	54	-20.1	-11.7	H
High Ch. 5700															
11.400	3.0	46.9	40.6	38.3	9.4	-35.9	0.0	0.7	59.4	53.1	74	54	-14.6	-0.9	V
11.400	3.0	45.8	37.7	38.3	9.4	-35.9	0.0	0.7	58.3	50.2	74	54	-15.7	-3.8	H

Rev. 11.10.08

f	Measurement Frequency	Amp	Preamp Gain	Avg Lim	Average Field Strength Limit
Dist	Distance to Antenna	D Corr	Distance Correct to 3 meters	Pk Lim	Peak Field Strength Limit
Read	Analyzer Reading	Avg	Average Field Strength @ 3 m	Avg Mar	Margin vs. Average Limit
AF	Antenna Factor	Peak	Calculated Peak Field Strength	Pk Mar	Margin vs. Peak Limit
CL	Cable Loss	HPF	High Pass Filter		

8.2.8. 802.11n HT20 MODE IN THE 5.6 GHz BAND

RESTRICTED BANDEDGE (LOW CHANNEL, HORIZONTAL)

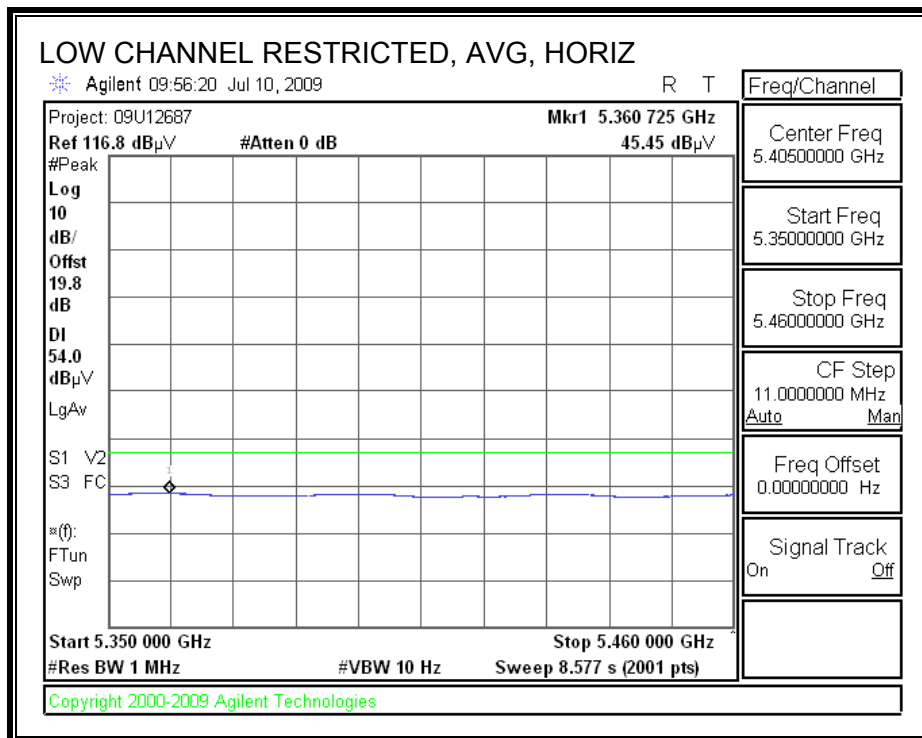
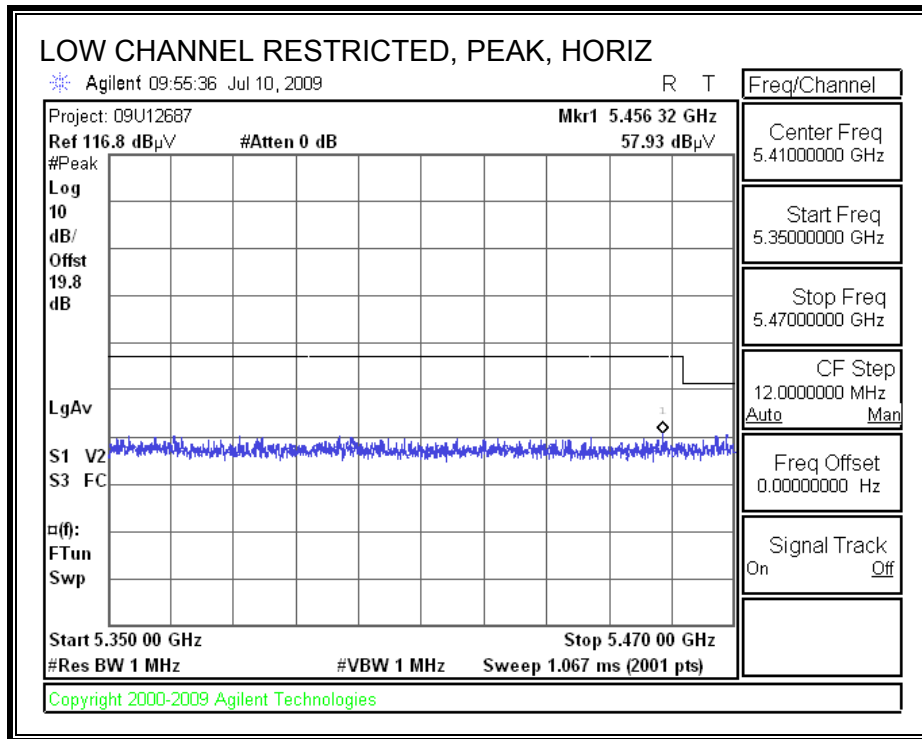

RESTRICTED BANDEDGE (LOW CHANNEL, VERTICAL)

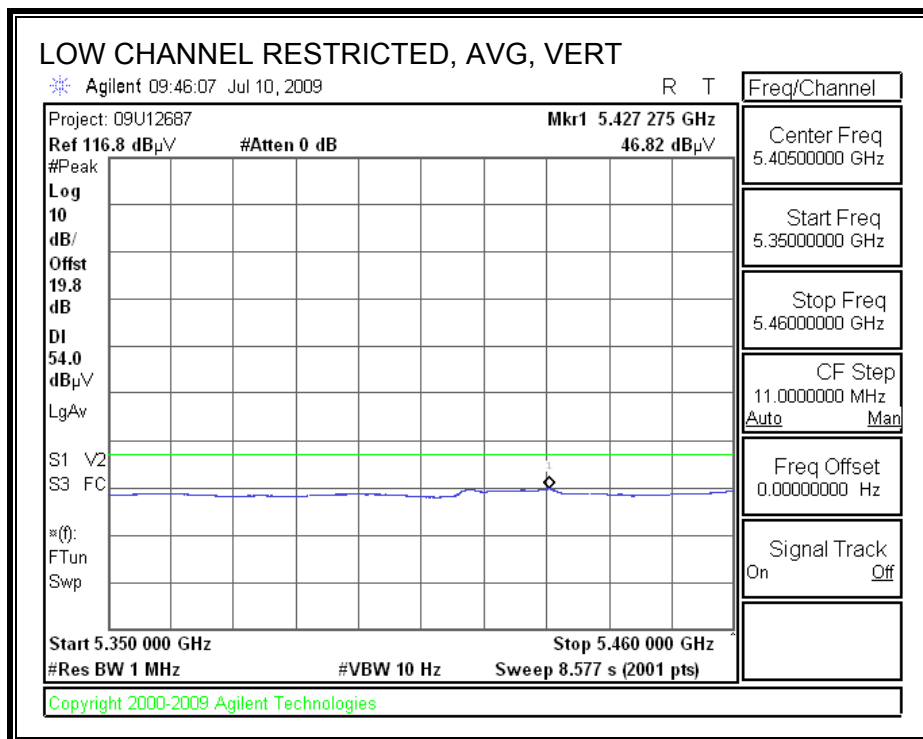
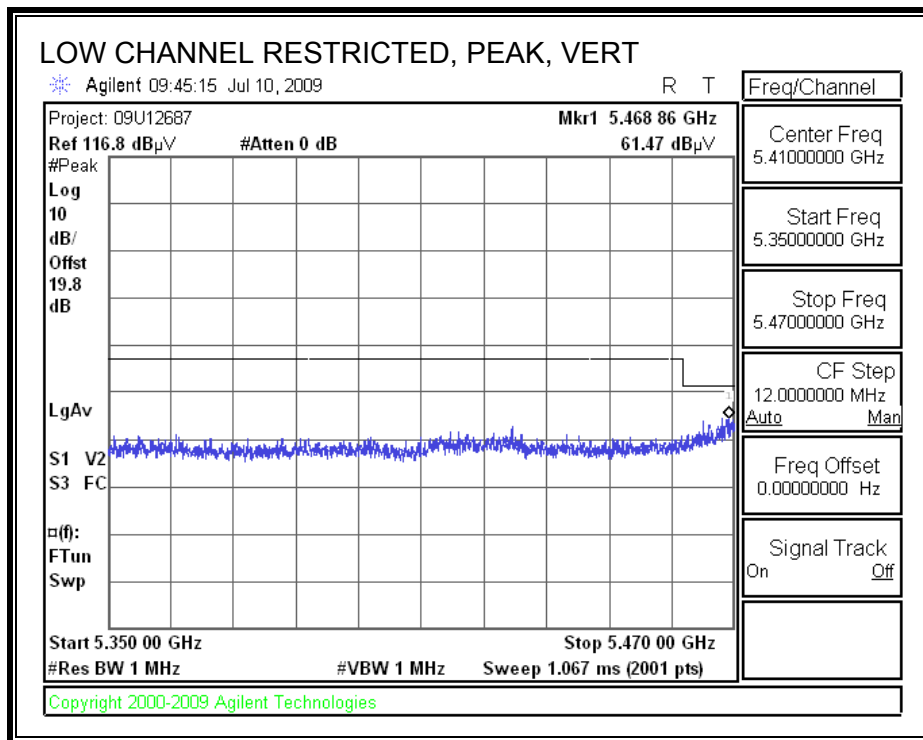

AUTHORIZED BANDEDGE (HIGH CHANNEL, VERTICAL)

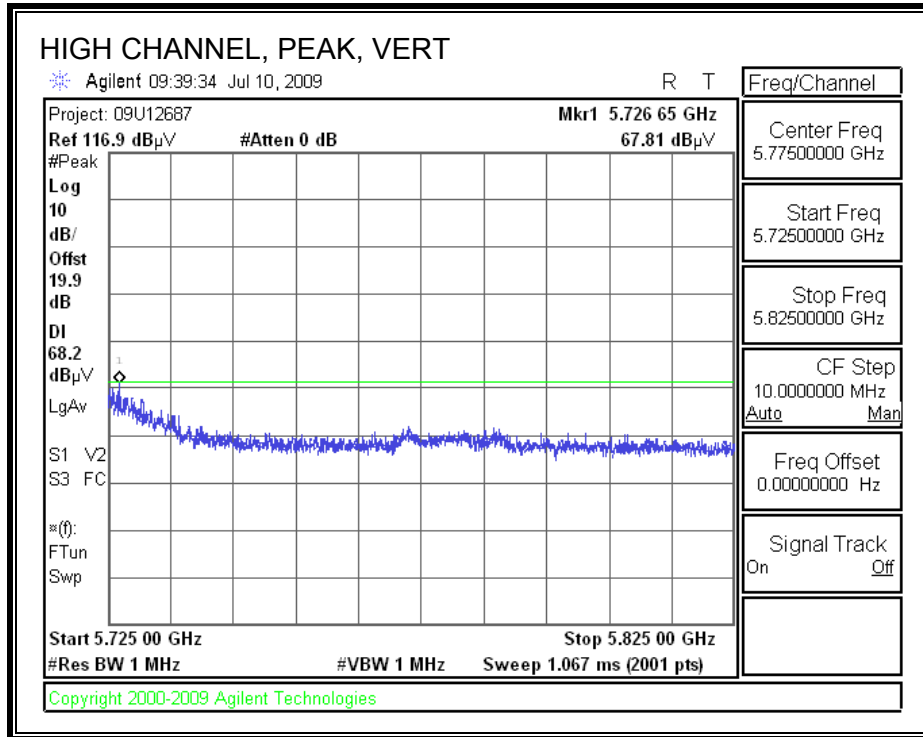

HARMONICS AND SPURIOUS EMISSIONS

High Frequency Measurement
 Compliance Certification Services, Fremont 5m Chamber

Company: Qualcomm
 Project #: 09U12687
 Date: 07/08/09
 Test Engineer: Doug Anderson
 Configuration: EUT w/Support Notebook PC
 Mode: Tx / HT20

Test Equipment:

Horn 1-18GHz	Pre-amplifier 1-26GHz	Pre-amplifier 26-40GHz	Horn > 18GHz	Limit
T73; S/N: 6717 @3m	T144 Miteq 3008A00931			FCC 15.205

Hi Frequency Cables

3' cable 22807700	12' cable 22807600	20' cable 22807500	HPF	Reject Filter	Peak Measurements RBW=VBW=1MHz
3' cable 22807700	12' cable 22807600	20' cable 22807500	HPF_7.6GHz		Average Measurements RBW=1MHz ; VBW=10Hz

f GHz	Dist (m)	Read Pk dBuV	Read Avg dBuV	AF dB/m	CL dB	Amp dB	D Corr dB	Filt dB	Peak dBuV/m	Avg dBuV/m	Pk Lim dBuV/m	Avg Lim dBuV/m	Pk Mar dB	Avg Mar dB	Notes (V/H)
Low Ch. 5500															
11.000	3.0	47.1	39.0	37.9	9.2	-36.3	0.0	0.7	58.6	50.5	74	54	-15.4	-3.5	V
11.000	3.0	43.0	33.1	37.9	9.2	-36.3	0.0	0.7	54.6	44.7	74	54	-19.4	-9.3	H
Mid. Ch. 5600															
11.200	3.0	47.3	39.8	38.1	9.3	-36.1	0.0	0.7	59.3	51.9	74	54	-14.7	-2.1	V
11.200	3.0	44.8	36.2	38.1	9.3	-36.1	0.0	0.7	56.9	48.2	74	54	-17.1	-5.8	H
High Ch. 5700															
11.400	3.0	47.5	40.9	38.3	9.4	-35.9	0.0	0.7	60.0	53.4	74	54	-14.0	-0.6	V
11.400	3.0	44.8	34.7	38.3	9.4	-35.9	0.0	0.7	57.3	47.3	74	54	-16.7	-6.7	H

Rev. 11.10.08

f	Measurement Frequency	Amp	Preamp Gain	Avg Lim	Average Field Strength Limit
Dist	Distance to Antenna	D Corr	Distance Correct to 3 meters	Pk Lim	Peak Field Strength Limit
Read	Analyzer Reading	Avg	Average Field Strength @ 3 m	Avg Mar	Margin vs. Average Limit
AF	Antenna Factor	Peak	Calculated Peak Field Strength	Pk Mar	Margin vs. Peak Limit
CL	Cable Loss	HPF	High Pass Filter		

8.2.9. 802.11n HT40 MODE IN THE 5.6 GHz BAND

RESTRICTED BANDEDGE (LOW CHANNEL, HORIZONTAL)

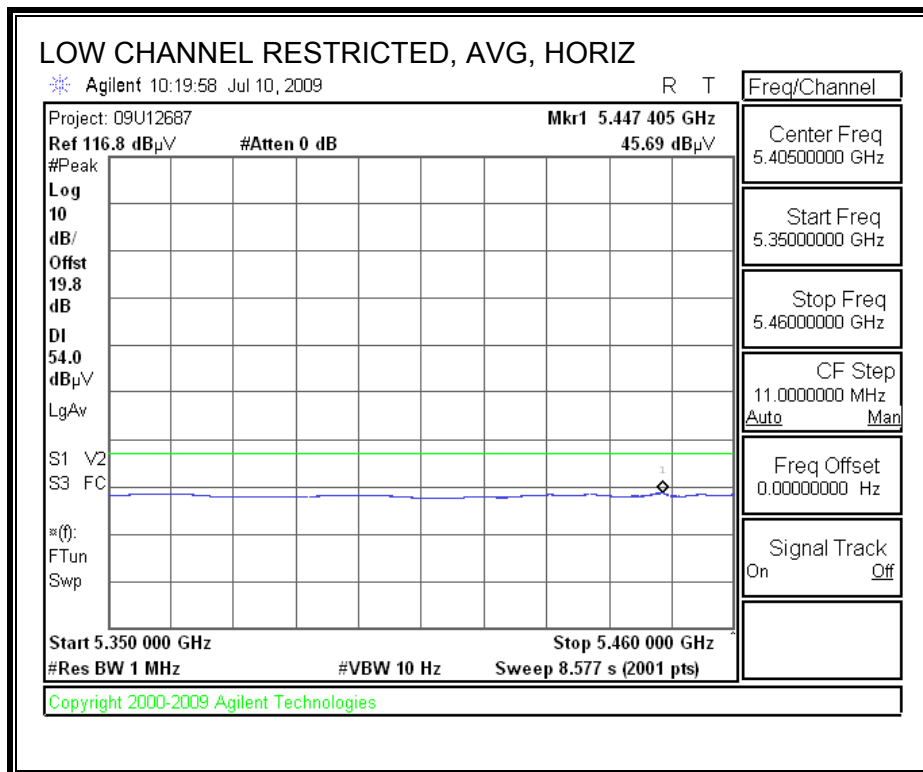
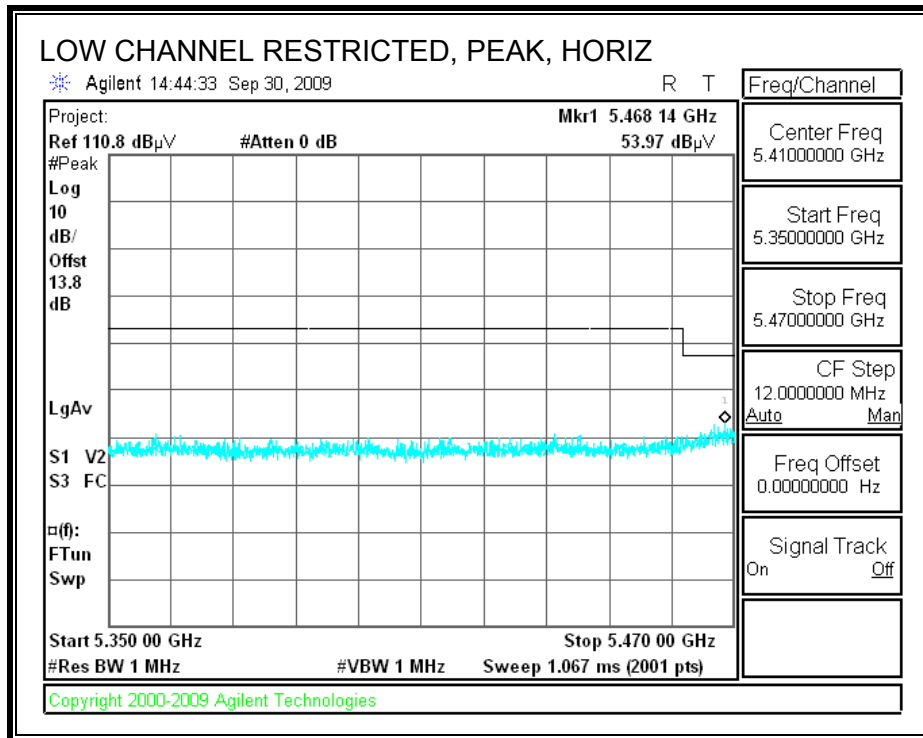

RESTRICTED BANDEDGE (LOW CHANNEL, VERTICAL)

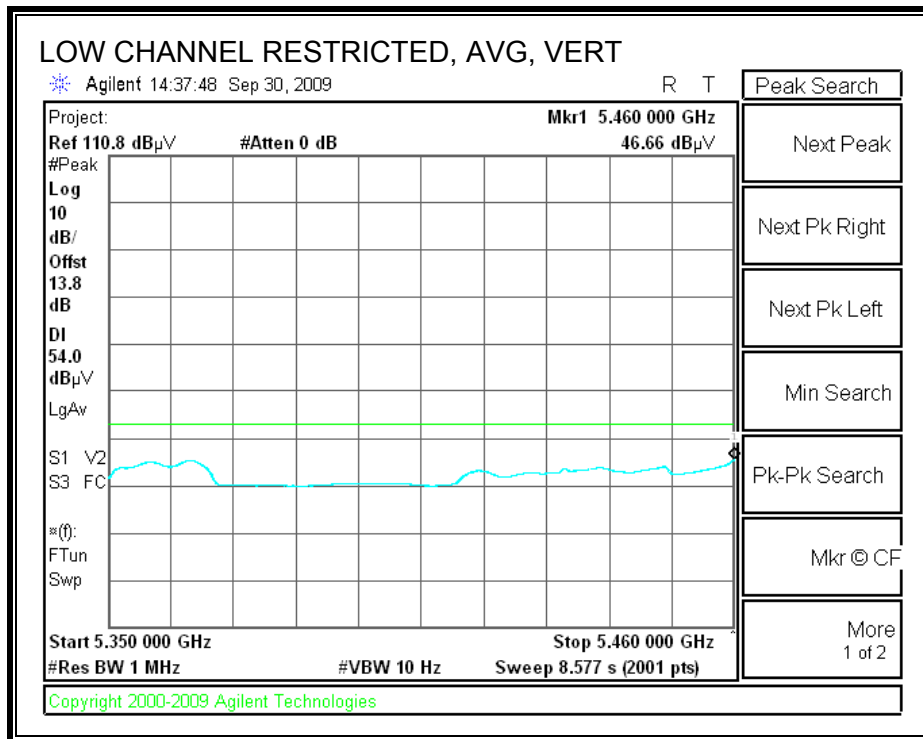
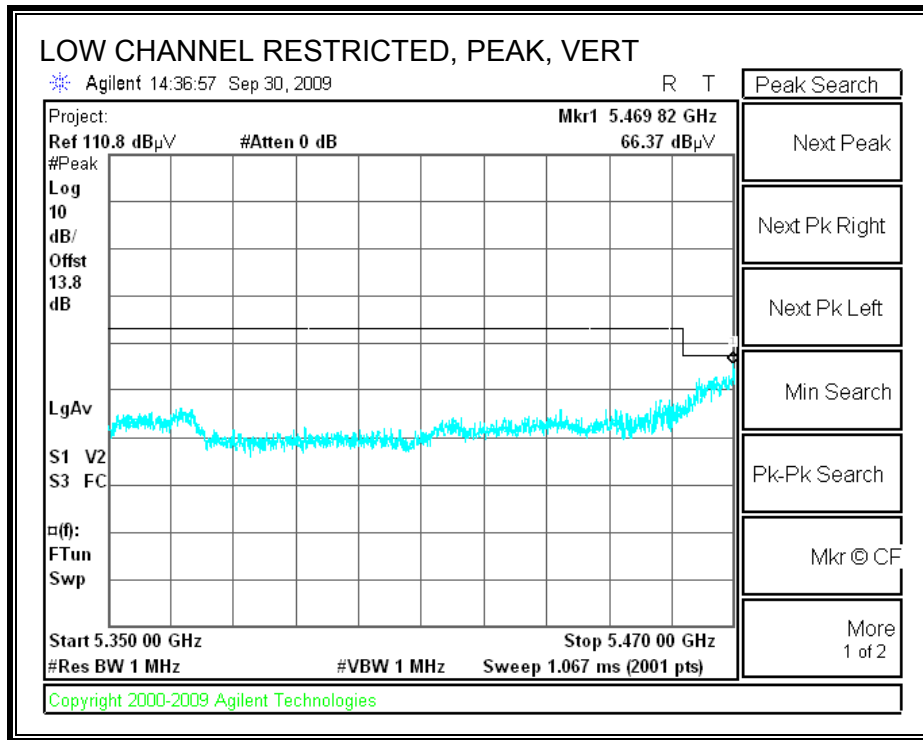

AUTHORIZED BANDEDGE (HIGH CHANNEL, VERTICAL)

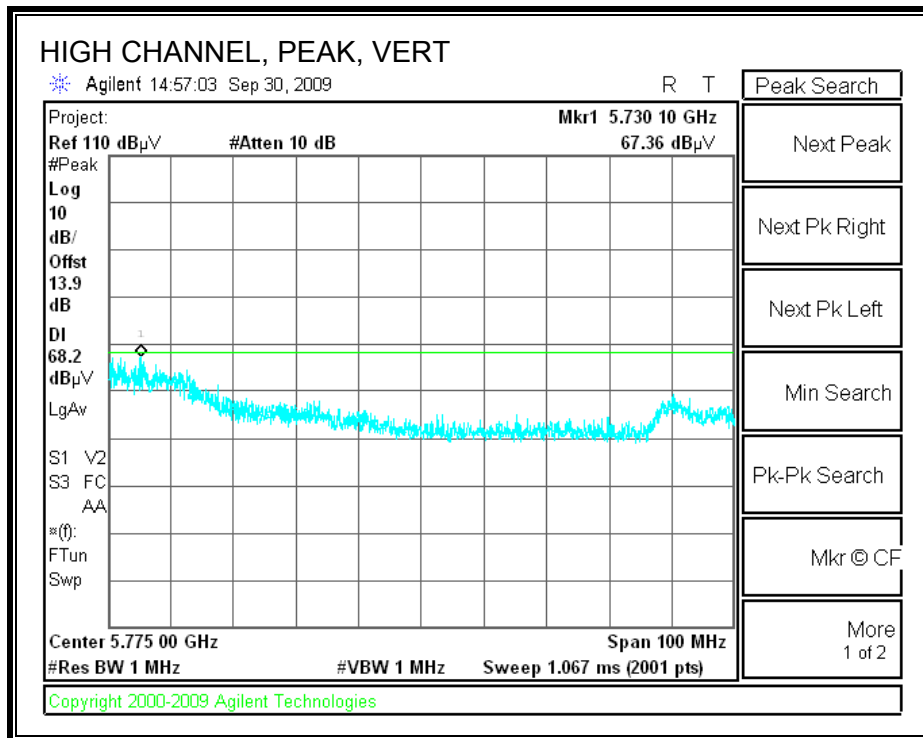

HARMONICS AND SPURIOUS EMISSIONS

High Frequency Measurement
 Compliance Certification Services, Fremont 5m Chamber

Company: Qualcomm
 Project #: 09U12687
 Date: 09/30/09
 Test Engineer: Thanh Nguyen
 Configuration: EUT w/Support Notebook PC
 Mode: Tx HT40_5.6GHz Band_MCS 31

Test Equipment:

Horn 1-18GHz	Pre-amplifier 1-26GHz	Pre-amplifier 26-40GHz	Horn > 18GHz	Limit
T73; S/N: 6717 @3m	T144 Miteq 3008A00931			FCC 15.205

Hi Frequency Cables

3' cable 22807700	12' cable 22807600	20' cable 22807500	HPF	Reject Filter	Peak Measurements RBW=VBW=1MHz <u>Average Measurements</u> RBW=1MHz; VBW=10Hz
3' cable 22807700	12' cable 22807600	20' cable 22807500	HPF_7.6GHz		

f	Dist	Read Pk	Read Avg.	AF	CL	Amp	D Corr	Fldr	Peak	Avg	Pk Lim	Avg Lim	Pk Mar	Avg Mar	Notes
GHz	(m)	dBuV	dBuV	dB/m	dB	dB	dB	dB	dBuV/m	dBuV/m	dBuV/m	dBuV/m	dB	dB	(V/H)
Low Ch. 5510MHz															
11.020	3.0	36.8	27.0	37.9	9.2	-36.3	0.0	0.7	48.4	38.6	74	54	-25.6	-15.4	V
11.020	3.0	32.5	25.5	37.9	9.2	-36.3	0.0	0.7	44.1	37.1	74	54	-29.9	-16.9	H
Mid Ch. 5590MHz															
11.180	3.0	40.1	32.5	38.1	9.3	-36.1	0.0	0.7	52.1	44.5	74	54	-21.9	-9.5	V
11.180	3.0	37.5	28.3	38.1	9.3	-36.1	0.0	0.7	49.5	40.3	74	54	-24.5	-13.7	H
High Ch. 5670MHz															
11.340	3.0	40.8	35.2	38.2	9.4	-36.0	0.0	0.7	53.2	47.6	74	54	-20.8	-6.4	V
11.340	3.0	37.6	28.3	38.2	9.4	-36.0	0.0	0.7	49.9	40.7	74	54	-24.1	-13.3	H

f	Measurement Frequency	Amp	Preamp Gain	Avg Lim	Average Field Strength Limit
Dist	Distance to Antenna	D Corr	Distance Correct to 3 meters	Pk Lim	Peak Field Strength Limit
Read	Analyzer Reading	Avg	Average Field Strength @ 3 m	Avg Mar	Margin vs. Average Limit
AF	Antenna Factor	Peak	Calculated Peak Field Strength	Pk Mar	Margin vs. Peak Limit
CL	Cable Loss	HPF	High Pass Filter		

8.3. WORST-CASE BELOW 1 GHz

SPURIOUS EMISSIONS 30 TO 1000 MHz (WORST-CASE CONFIGURATION, HORIZONTAL)

HORIZONTAL													
30-1000MHz Frequency Measurement													
Compliance Certification Services, Fremont 5m Chamber													
Test Engr:		Thanh Nguyen											
Date:		06/25/09											
Project #:		09U12652											
Company:		QualCom Inc.											
EUT Description:		802.11n 4x4 WLAN module											
EUT M/N:		65-VN780-P1											
Test Target:		FCC Class B											
Mode Oper:		Tx worst case UNII band											
f	Measurement Frequency	Amp	Preamp Gain	Margin	Margin vs. Limit								
Dist	Distance to Antenna	D Corr	Distance Correct to 3 meters										
Read	Analyzer Reading	Filter	Filter Insert Loss										
AF	Antenna Factor	Corr.	Calculated Field Strength										
CL	Cable Loss	Limit	Field Strength Limit										
f	Dist	Read	AF	CL	Amp	D Corr	Filter	Corr.	Limit	Margin	Ant. Pol	Det.	Notes
MHz	(m)	dBuV	dB/m	dB	dB	dB	dB	dBuV/m	dBuV/m	dB	V/H	P/A/QP	
90.002	3.0	52.1	7.6	0.8	28.3	0.0	0.0	32.2	43.5	-11.3	H	EP	
234.608	3.0	51.0	11.9	1.3	28.2	0.0	0.0	36.0	46.0	-10.0	H	EP	
299.171	3.0	51.5	13.4	1.5	28.1	0.0	0.0	38.2	46.0	-7.8	H	EP	
429.136	3.0	45.8	15.4	1.9	28.0	0.0	0.0	35.1	46.0	-10.9	H	EP	
639.985	3.0	44.1	18.9	2.3	27.4	0.0	0.0	37.9	46.0	-8.1	H	EP	
Rev. 1.27.09													
Note: No other emissions were detected above the system noise floor.													

SPURIOUS EMISSIONS 30 TO 1000 MHz (WORST-CASE CONFIGURATION, VERTICAL)

VERTICAL

30-1000MHz Frequency Measurement
 Compliance Certification Services, Fremont 5m Chamber

Test Engr: Thanh Nguyen
Date: 06/25/09
Project #: 09U12652
Company: QualCom Inc.
EUT Description: 802.11n 4x4 WLAN module
EUT M/N: 65-VN780-P1
Test Target: FCC Class B
Mode Oper: Tx worst case UNII band

f	Measurement Frequency	Amp	Preamp Gain	Margin	Margin vs. Limit
Dist	Distance to Antenna	D Corr	Distance Correct to 3 meters		
Read	Analyzer Reading	Filter	Filter Insert Loss		
AF	Antenna Factor	Corr.	Calculated Field Strength		
CL	Cable Loss	Limit	Field Strength Limit		

f MHz	Dist (m)	Read dBuV	AF dB/m	CL dB	Amp dB	D Corr dB	Filter dB	Corr. dBuV/m	Limit dBuV/m	Margin dB	Ant. Pol. V/H	Det. P/A/QP	Notes
61.441	3.0	53.4	7.9	0.7	28.4	0.0	0.0	33.7	40.0	-6.3	V	EP	
142.925	3.0	45.9	13.1	1.1	28.3	0.0	0.0	31.8	43.5	-11.7	V	EP	
498.379	3.0	39.0	16.7	2.0	27.8	0.0	0.0	29.9	46.0	-16.1	V	EP	
599.303	3.0	41.0	18.4	2.2	27.5	0.0	0.0	34.1	46.0	-11.9	V	EP	
799.952	3.0	43.7	21.0	2.6	27.4	0.0	0.0	39.9	46.0	-6.1	V	EP	

Rev. 1.27.09

Note: No other emissions were detected above the system noise floor.

9. AC POWER LINE CONDUCTED EMISSIONS

LIMITS

FCC §15.207 (a)

RSS-Gen 7.2.2

Frequency of Emission (MHz)	Conducted Limit (dBuV)	
	Quasi-peak	Average
0.15-0.5	66 to 56*	56 to 46*
0.5-5	56	46
5-30	60	50

*Decreases with the logarithm of the frequency.

TEST PROCEDURE

The EUT is placed on a non-conducting table 40 cm from the vertical ground plane and 80 cm above the horizontal ground plane. The EUT is configured in accordance with ANSI C63.4.

The receiver is set to a resolution bandwidth of 9 kHz. Peak detection is used unless otherwise noted as quasi-peak or average.

Line conducted data is recorded for both NEUTRAL and HOT lines.

RESULTS

6 WORST EMISSIONS

CONDUCTED EMISSIONS DATA (115VAC 60Hz)									
Freq.	Reading			Class	Limit	EN B	Margin		Remark
(MHz)	PK (dBuV)	QP (dBuV)	AV (dBuV)	(dB)	QP	AV	QP (dB)	AV (dB)	L1 / L2
0.22	49.94	--	36.55	0.00	62.74	52.74	-12.80	-16.19	L1
0.33	39.76	--	28.62	0.00	59.35	49.35	-19.59	-20.73	L1
21.15	41.63	--	37.25	0.00	60.00	50.00	-18.37	-12.75	L1
0.22	49.89	--	36.03	0.00	62.82	52.82	-12.93	-16.79	L2
0.33	39.80	--	27.12	0.00	59.35	49.35	-19.55	-22.23	L2
21.71	38.81	--	32.20	0.00	60.00	50.00	-21.19	-17.80	L2
6 Worst Data									

LINE 1 RESULTS

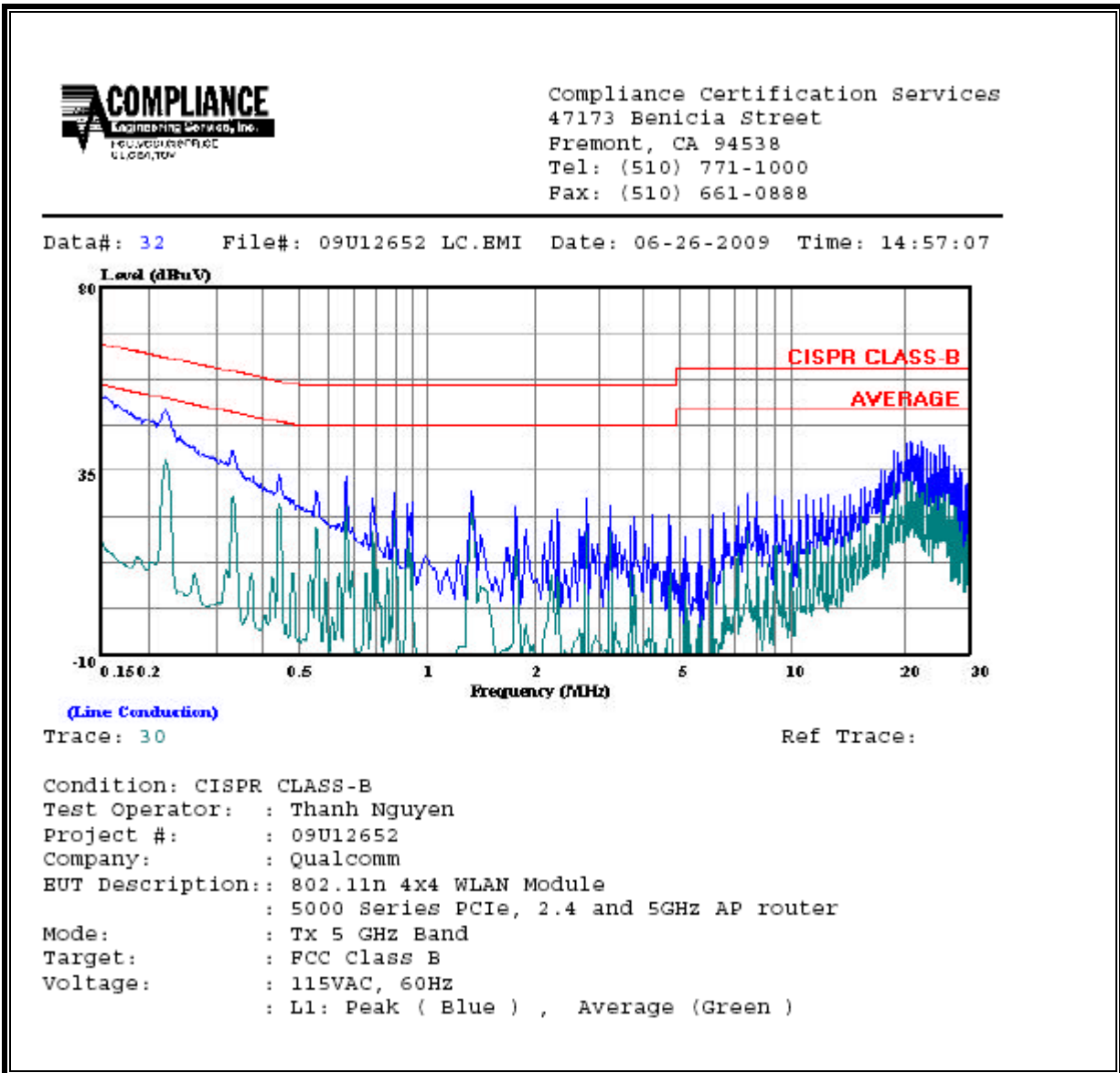

LINE 2 RESULTS

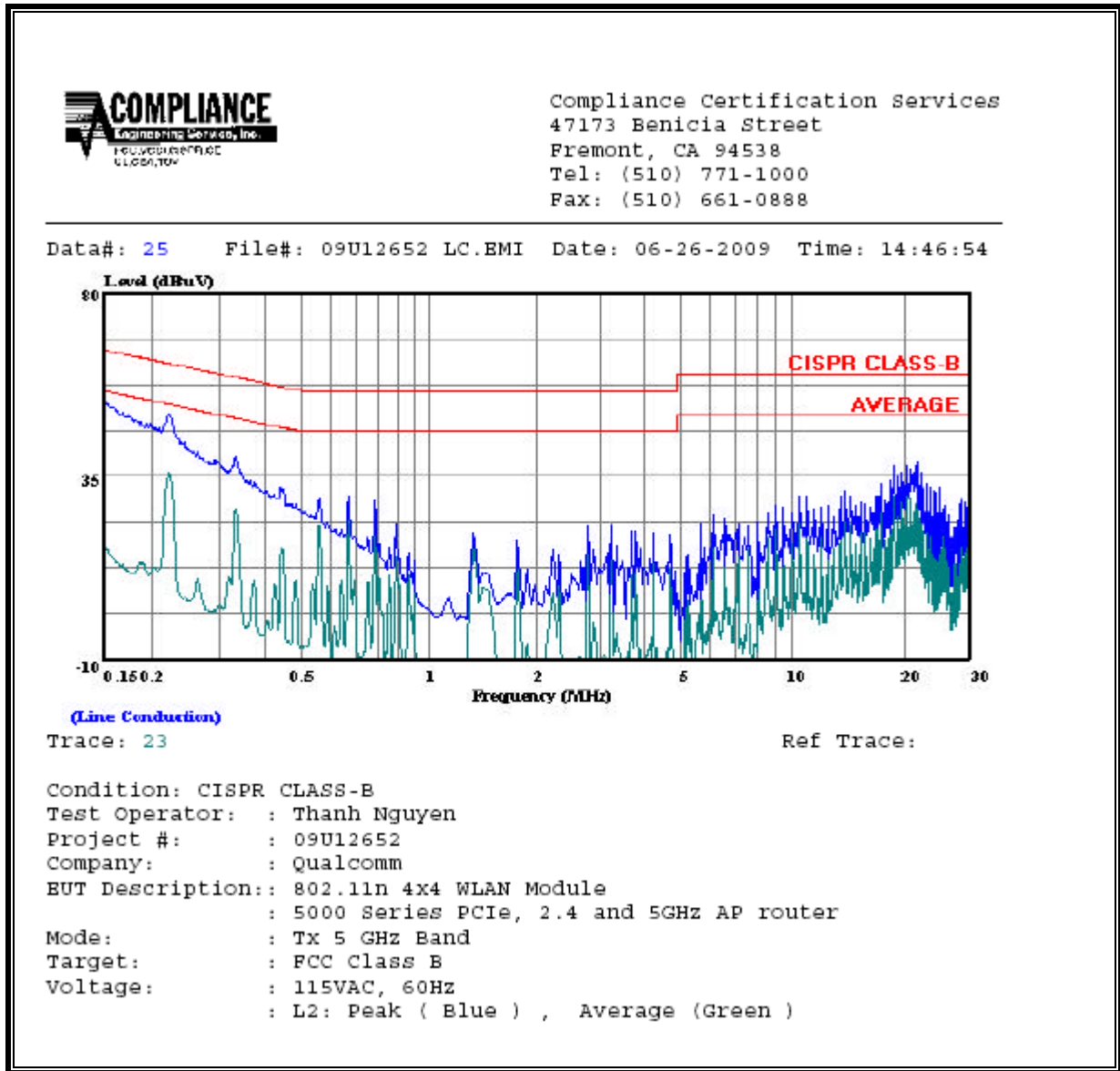

10. DYNAMIC FREQUENCY SELECTION

10.1. OVERVIEW

10.1.1. LIMITS

INDUSTRY CANADA

IC RSS-210 is closely harmonized with FCC Part 15 DFS rules. The deviations are as follows:

RSS-210 Issue 7 A9.4 (b) (ii) **Channel Availability Check Time:** ...

Additional requirements for the band 5600-5650 MHz: Until further notice, devices subject to this Section shall not be capable of transmitting in the band 5600-5650 MHz, so that Environment Canada weather radars operating in this band are protected.

RSS-210 Issue 7 A9.4 (b) (iv) **Channel closing time:** the maximum channel closing time is 260 ms.

FCC

§15.407 (h) and FCC 06-96 APPENDIX "COMPLIANCE MEASUREMENT PROCEDURES FOR UNLICENSED-NATIONAL INFORMATION INFRASTRUCTURE DEVCIES OPERATING IN THE 5250-5350 MHz AND 5470-5725 MHz BANDS INCORPORATING DYNAMIC FREQUENCY SELECTION".

Table 1: Applicability of DFS requirements prior to use of a channel

Requirement	Operational Mode		
	Master	Client (without radar detection)	Client (with radar detection)
Non-Occupancy Period	Yes	Not required	Yes
DFS Detection Threshold	Yes	Not required	Yes
Channel Availability Check Time	Yes	Not required	Not required
Uniform Spreading	Yes	Not required	Not required

Table 2: Applicability of DFS requirements during normal operation

Requirement	Operational Mode		
	Master	Client (without DFS)	Client (with DFS)
DFS Detection Threshold	Yes	Not required	Yes
Channel Closing Transmission Time	Yes	Yes	Yes
Channel Move Time	Yes	Yes	Yes

Table 3: Interference Threshold values, Master or Client incorporating In-Service Monitoring

Maximum Transmit Power	Value (see note)
≥ 200 milliwatt	-64 dBm
< 200 milliwatt	-62 dBm
<p>Note 1: This is the level at the input of the receiver assuming a 0 dBi receive antenna Note 2: Throughout these test procedures an additional 1 dB has been added to the amplitude of the test transmission waveforms to account for variations in measurement equipment. This will ensure that the test signal is at or above the detection threshold level to trigger a DFS response.</p>	

Table 4: DFS Response requirement values

Parameter	Value
<i>Non-occupancy period</i>	30 minutes
<i>Channel Availability Check Time</i>	60 seconds
<i>Channel Move Time</i>	10 seconds
<i>Channel Closing Transmission Time</i>	200 milliseconds + approx. 60 milliseconds over remaining 10 second period
<p>The instant that the <i>Channel Move Time</i> and the <i>Channel Closing Transmission Time</i> begins is as follows: For the Short pulse radar Test Signals this instant is the end of the <i>Burst</i>. For the Frequency Hopping radar Test Signal, this instant is the end of the last radar burst generated. For the Long Pulse radar Test Signal this instant is the end of the 12 second period defining the radar transmission. The Channel Closing Transmission Time is comprised of 200 milliseconds starting at the beginning of the Channel Move Time plus any additional intermittent control signals required to facilitate channel changes (an aggregate of approximately 60 milliseconds) during the remainder of the 10 second period. The aggregate duration of control signals will not count quiet periods in between transmissions.</p>	

Table 5 – Short Pulse Radar Test Waveforms

Radar Type	Pulse Width (Microseconds)	PRI (Microseconds)	Pulses	Minimum Percentage of Successful Detection	Minimum Trials
1	1	1428	18	60%	30
2	1-5	150-230	23-29	60%	30
3	6-10	200-500	16-18	60%	30
4	11-20	200-500	12-16	60%	30
Aggregate (Radar Types 1-4)				80%	120

Table 6 – Long Pulse Radar Test Signal

Radar Waveform	Bursts	Pulses per Burst	Pulse Width (µsec)	Chirp Width (MHz)	PRI (µsec)	Minimum Percentage of Successful Detection	Minimum Trials
5	8-20	1-3	50-100	5-20	1000-2000	80%	30

Table 7 – Frequency Hopping Radar Test Signal

Radar Waveform	Pulse Width (µsec)	PRI (µsec)	Burst Length (ms)	Pulses per Hop	Hopping Rate (kHz)	Minimum Percentage of Successful Detection	Minimum Trials
6	1	333	300	9	.333	70%	30

10.1.2. TEST AND MEASUREMENT SYSTEM

RADIATED METHOD SYSTEM BLOCK DIAGRAM

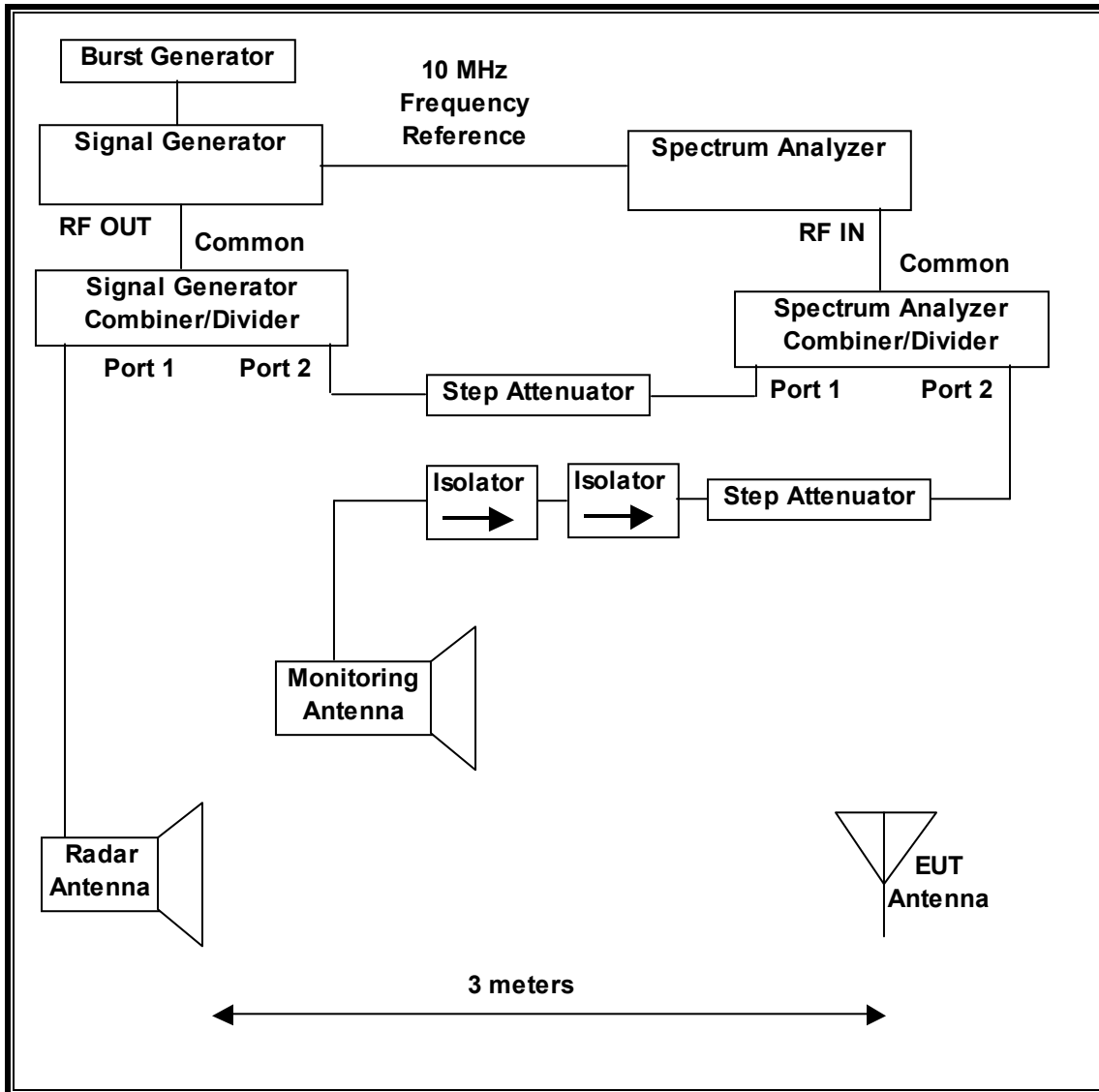

SYSTEM OVERVIEW

The short pulse and long pulse signal generating system utilizes the NTIA software. The Vector Signal Generator has been validated by the NTIA. The hopping signal generating system utilizes the CCS simulated hopping method and system, which has been validated by the DoD, FCC and NTIA. The software selects waveform parameters from within the bounds of the signal type on a random basis using uniform distribution.

The signal monitoring equipment consists of a spectrum analyzer set to display 8001 bins on the horizontal axis. The time-domain resolution is 2 msec / bin with a 16 second sweep time, meeting the 10 second short pulse reporting criteria. The aggregate ON time is calculated by multiplying the number of bins above a threshold during a particular observation period by the dwell time per bin, with the analyzer set to peak detection and max hold.

SYSTEM CALIBRATION

A 50-ohm load is connected in place of the spectrum analyzer, and the spectrum analyzer is connected to a horn antenna via a coaxial cable, with the reference level offset set to (horn antenna gain – coaxial cable loss). The signal generator is set to CW mode. The amplitude of the signal generator is adjusted to yield a level of –64 dBm as measured on the spectrum analyzer.

Without changing any of the instrument settings, the spectrum analyzer is reconnected to the Common port of the Spectrum Analyzer Combiner/Divider. Measure the amplitude and calculate the difference from –64 dBm. Adjust the Reference Level Offset of the spectrum analyzer to this difference.

The spectrum analyzer displays the level of the signal generator as received at the antenna ports of the Master Device. The interference detection threshold may be varied from the calibrated value of –64 dBm and the spectrum analyzer will still indicate the level as received by the Master Device.

ADJUSTMENT OF DISPLAYED TRAFFIC LEVEL

Establish a link between the Master and Slave, adjusting the distance between the units as needed to provide a suitable received level at the Master and Slave devices. Stream the video test file to generate WLAN traffic. Confirm that the WLAN traffic level, as displayed on the spectrum analyzer, is at lower amplitude than the radar detection threshold.

TEST AND MEASUREMENT EQUIPMENT

The following test and measurement equipment was utilized for the DFS tests documented in this report:

TEST EQUIPMENT LIST				
Description	Manufacturer	Model	Serial Number	Cal Due
Spectrum Analyzer, 26.5 GHz	Agilent / HP	E4407B	C01098	02/07/10
Vector signal generator, 20GHz	Agilent / HP	E8267C	C01066	11/16/09

10.1.3. SETUP OF EUT

RADIATED METHOD EUT TEST SETUP

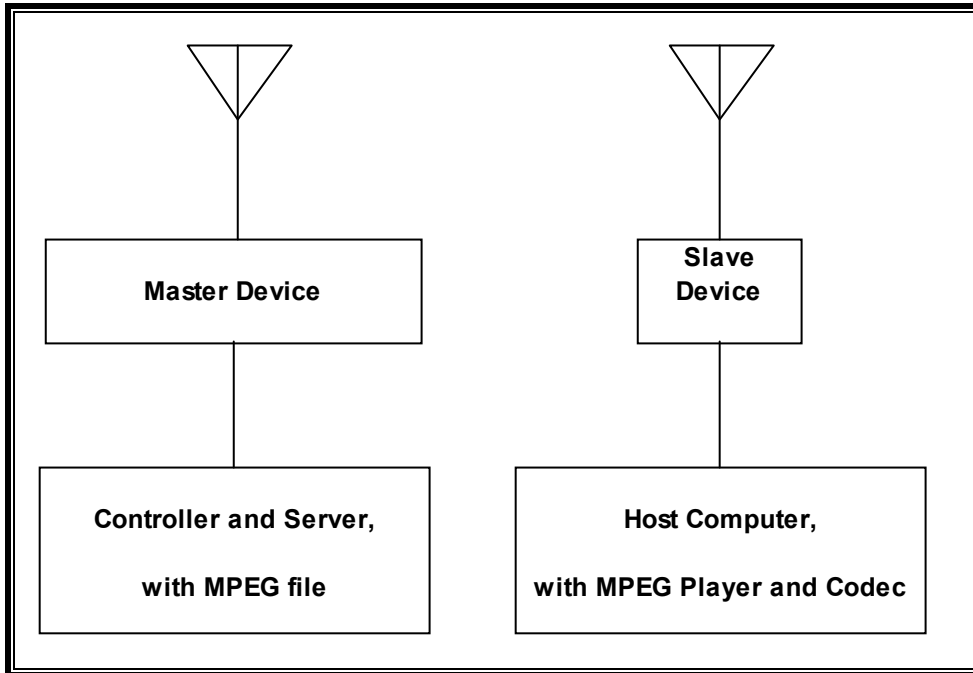

SUPPORT EQUIPMENT

The following test and measurement equipment was utilized for the DFS tests documented in this report:

PERIPHERAL SUPPORT EQUIPMENT LIST				
Description	Manufacturer	Model	Serial Number	FCC ID
Wireless Access Point (Master Device)	Cisco	AIR-AP1252AG-A-K9	FTX120690N2	LDK102061
AC Adapter (AP)	Delta Electronics	EADP-45BB B	DTH112490BD	DoC
Notebook PC (Host)	Dell	PP18L	10657517255	DoC
AC Adapter (Host PC)	Lite On Technology Corp.	LA65SN0-00	CN-ODF263-71615-687-49E	DoC
Notebook PC (Client)	IBM	Type 2668-46U	L3-XDLW 06/02	DoC
AC Adapter (Client PC)	IBM	08K8212	11S08K8212Z1Z7UB4BX0FA	DoC
USB to RS-232 Adapter	Keyspan	USA-19HS	02300	DoC
AC Adapter (EUT)	PI Electronics	P030WF120A	910000079	DoC

10.1.4. DESCRIPTION OF EUT

The EUT operates over the 5250-5350 MHz and 5470-5725 MHz ranges.

The EUT is a Slave Device without radar detection.

The highest power level within these bands is 26.24 dBm EIRP in the 5250-5350 MHz band and 23.77 dBm EIRP in the 5470-5725 MHz band.

The only antenna assembly utilized with the EUT has a gain of 3 dBi; in the 802.11a legacy mode it has an effective transmit antenna gain of 6.01 dBi.

Four identical antennas are utilized to meet the diversity and MIMO operational requirement, except in the 802.11a mode where two identical antennas are active for the transmitter and four identical antennas are active for the receiver.

The EUT uses four transmitter/receiver chains, each connected to an antenna to perform radiated tests.

WLAN traffic is generated by streaming the video file TestFile.mp2 "6 ½ Magic Hours" from the Master to the Slave in full motion video mode using the media player with the V2.61 Codec package.

TPC is not required since the maximum EIRP is less than 500 mW (27 dBm).

The EUT utilizes the 802.11a/n architecture. Two nominal channel bandwidths are implemented: 20 MHz and 40 MHz.

The software installed in the EUT is version 5.0.300.23.

OVERVIEW OF MASTER DEVICE WITH RESPECT TO §15.407 (h) REQUIREMENTS

The Master Device is a Cisco Access Point, FCC ID: LDK102061. The minimum antenna gain for the Master Device is 3.5 dBi.

The rated output power of the Master unit is > 23dBm (EIRP). Therefore the required interference threshold level is -64 dBm. After correction for antenna gain and procedural adjustments, the required radiated threshold is $-64 + 1 = -63$ dBm.

The calibrated radiated DFS Detection Threshold level is set to -64 dBm. The tested level is lower than the required level hence it provides margin to the limit.

10.2. 20 MHz BANDWIDTH RESULTS

10.2.1. TEST CHANNEL

All tests were performed at a channel center frequency of 5500 MHz.

10.2.2. PLOTS OF RADAR WAVEFORM AND WLAN TRAFFIC

PLOTS OF RADAR WAVEFORM

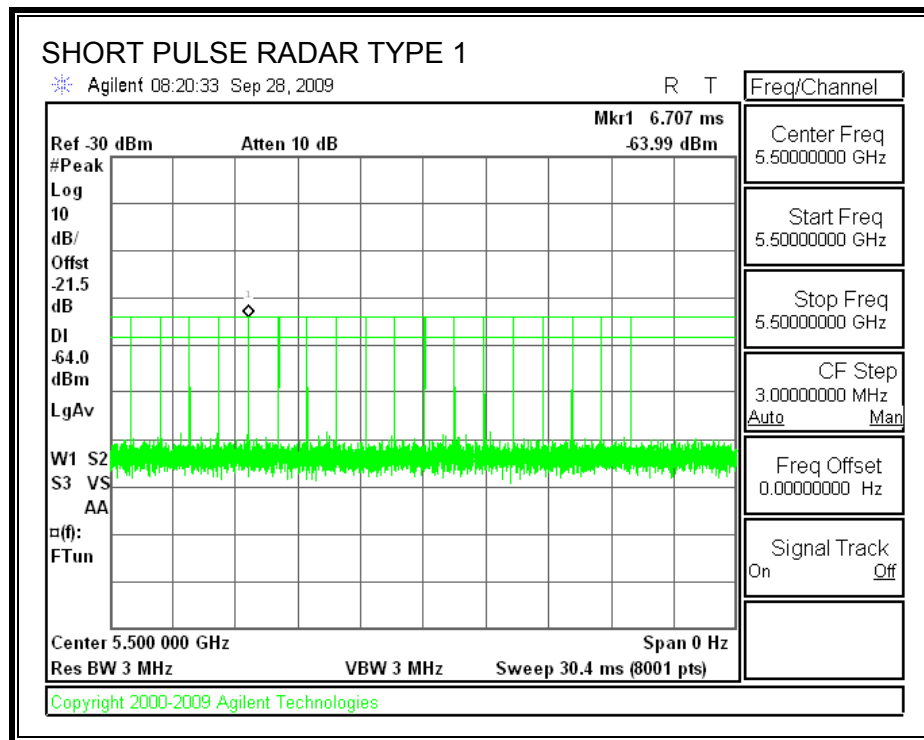

PLOT OF WLAN TRAFFIC

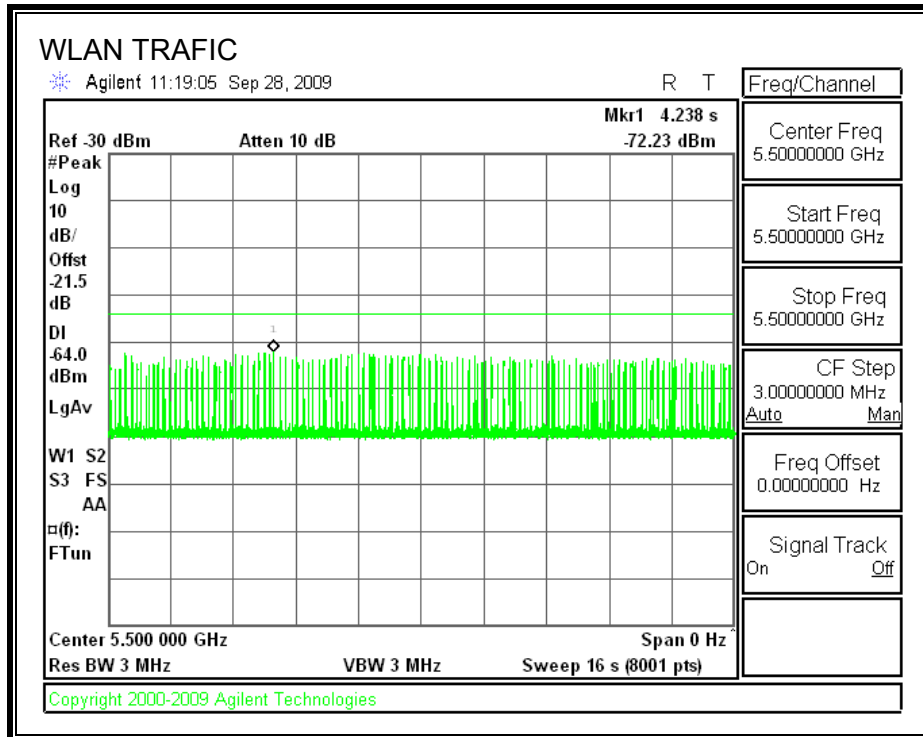

10.2.3. MOVE AND CLOSING TIME

REPORTING NOTES

The reference marker is set at the end of last radar pulse.

The delta marker is set at the end of the last WLAN transmission following the radar pulse. This delta is the channel move time.

The aggregate channel closing transmission time is calculated as follows:

Aggregate Transmission Time =
 (Number of analyzer bins showing transmission) * (dwell time per bin)

The observation period over which the FCC aggregate time is calculated begins at (Reference Marker + 200 msec) and ends no earlier than (Reference Marker + 10 sec).

The observation period over which the IC aggregate time is calculated begins at (Reference Marker) and ends no earlier than (Reference Marker + 10 sec).

RESULTS

Agency	Channel Move Time (sec)	Limit (sec)
FCC / IC	0.0	10

Agency	Aggregate Channel Closing Transmission Time (msec)	Limit (msec)
FCC	0.0	60
IC	0.0	260

MOVE TIME

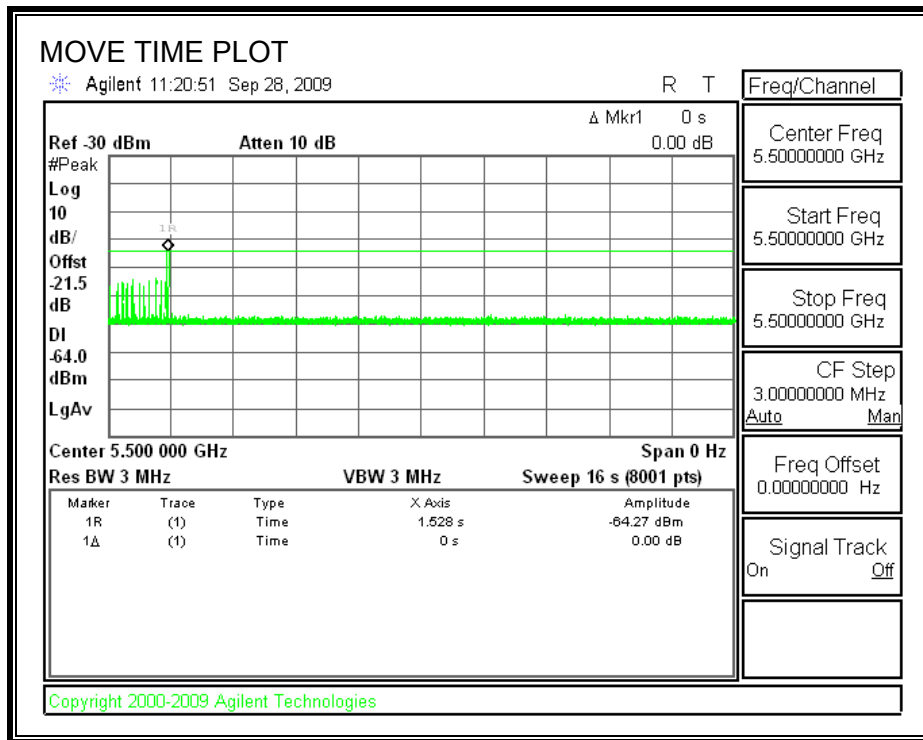

CHANNEL CLOSING TIME

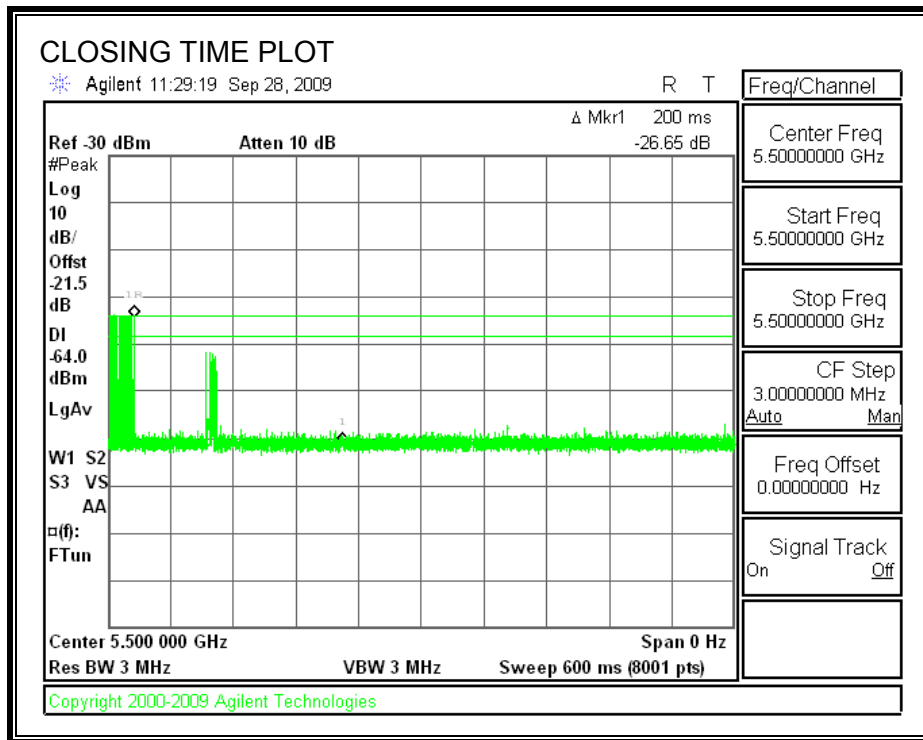

AGGREGATE CHANNEL CLOSING TRANSMISSION TIME

No transmissions are observed during the FCC aggregate monitoring period.

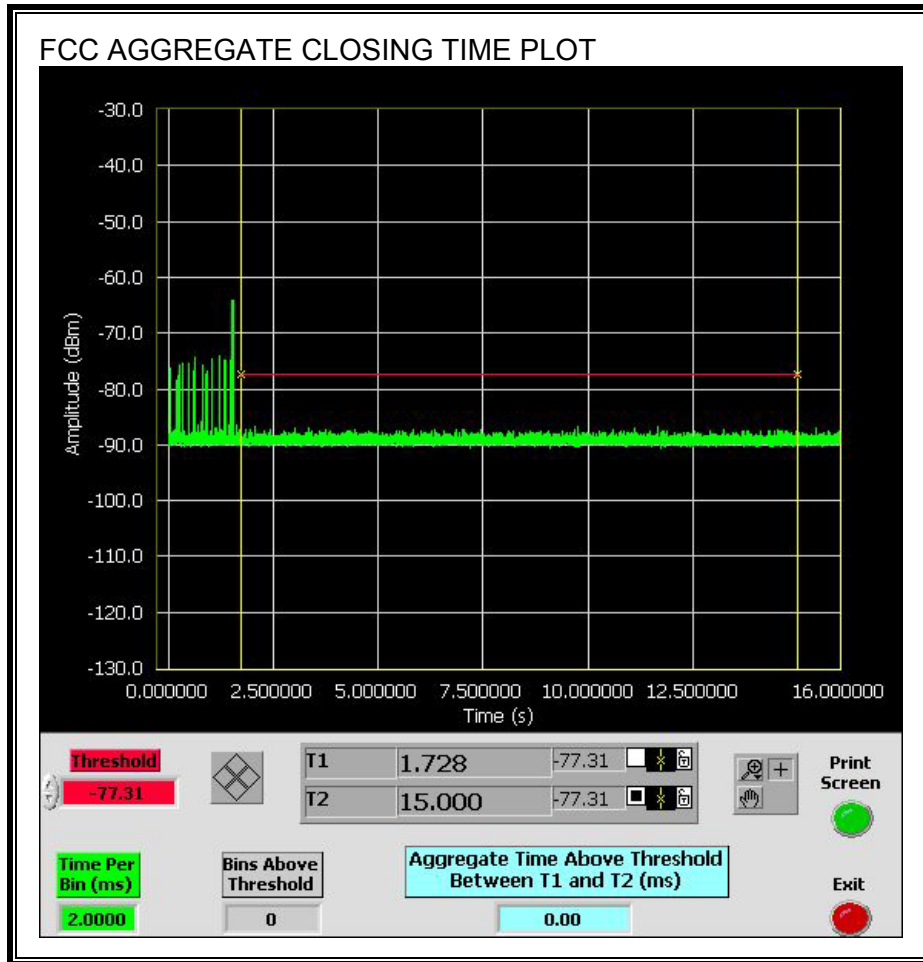

No transmissions are observed during the IC aggregate monitoring period.

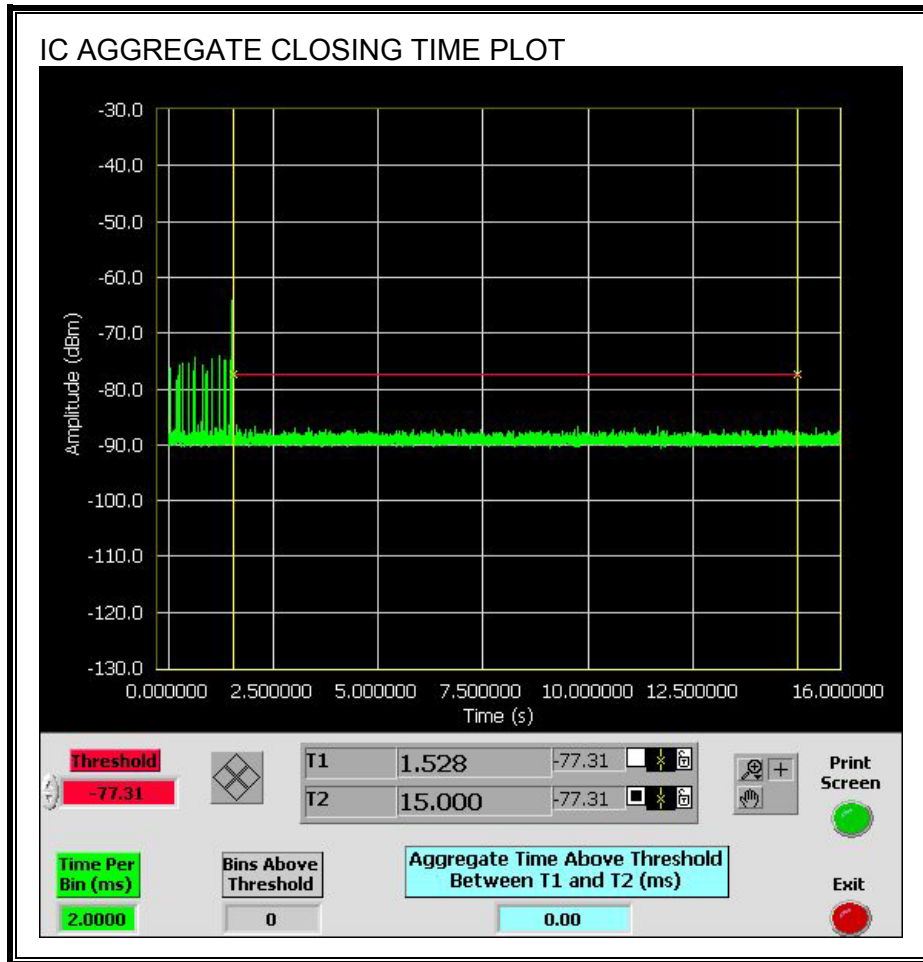

10.3. 40 MHz BANDWIDTH RESULTS

10.3.1. TEST CHANNEL

All tests were performed at a channel center frequency of 5510 MHz.

10.3.2. PLOTS OF RADAR WAVEFORM AND WLAN TRAFFIC

PLOTS OF RADAR WAVEFORM

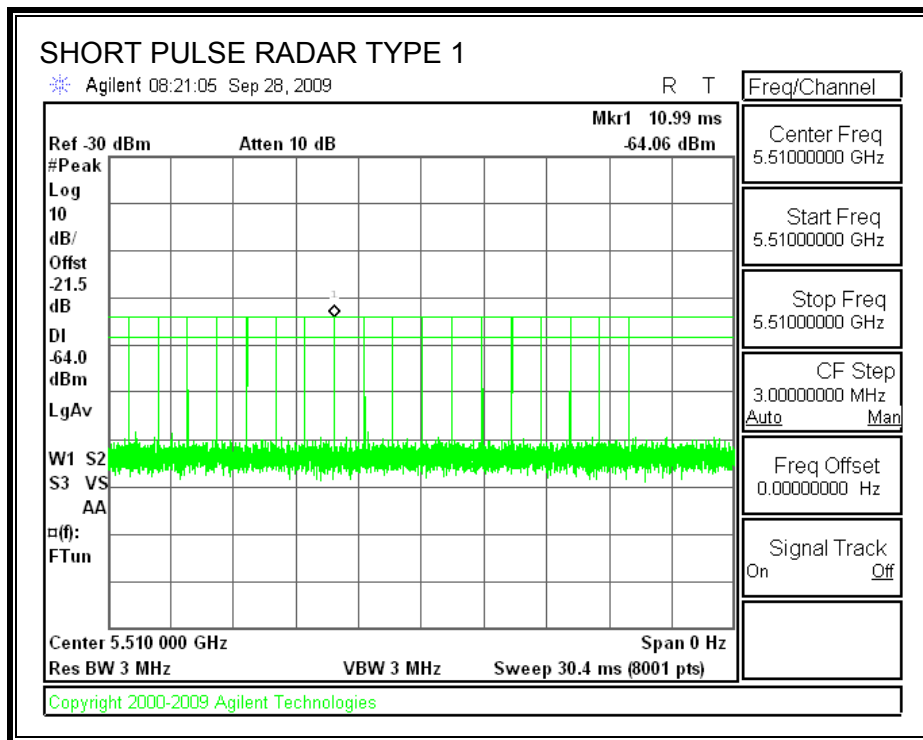

PLOT OF WLAN TRAFFIC

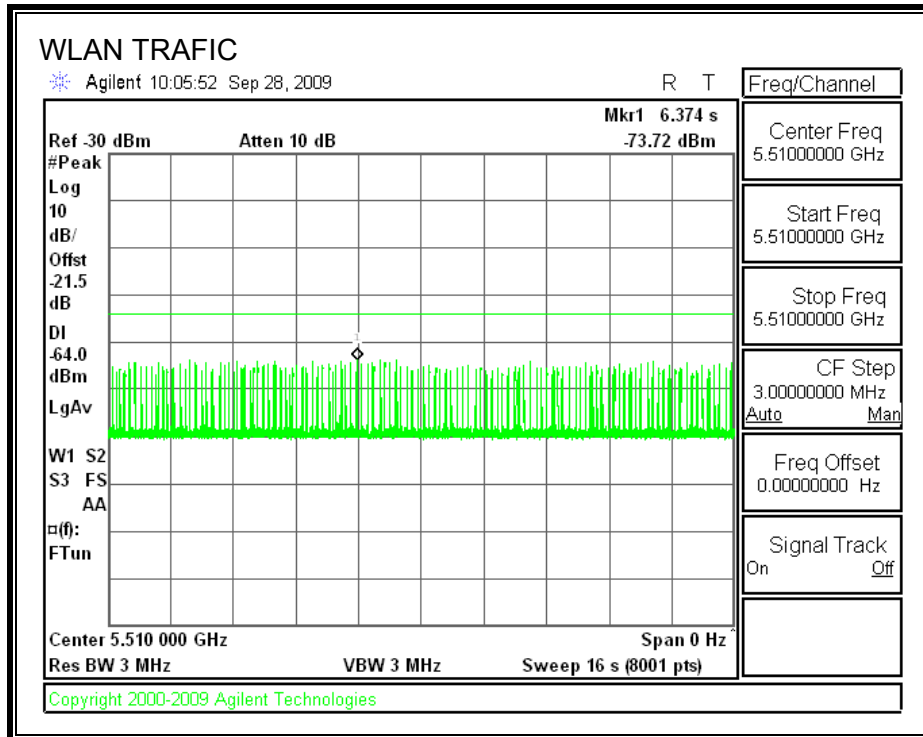

10.3.3. MOVE AND CLOSING TIME

REPORTING NOTES

The reference marker is set at the end of last radar pulse.

The delta marker is set at the end of the last WLAN transmission following the radar pulse. This delta is the channel move time.

The aggregate channel closing transmission time is calculated as follows:

Aggregate Transmission Time =
 (Number of analyzer bins showing transmission) * (dwell time per bin)

The observation period over which the FCC aggregate time is calculated begins at (Reference Marker + 200 msec) and ends no earlier than (Reference Marker + 10 sec).

The observation period over which the IC aggregate time is calculated begins at (Reference Marker) and ends no earlier than (Reference Marker + 10 sec).

RESULTS

Agency	Channel Move Time (sec)	Limit (sec)
FCC / IC	0.0	10

Agency	Aggregate Channel Closing Transmission Time (msec)	Limit (msec)
FCC	0.0	60
IC	0.0	260

MOVE TIME

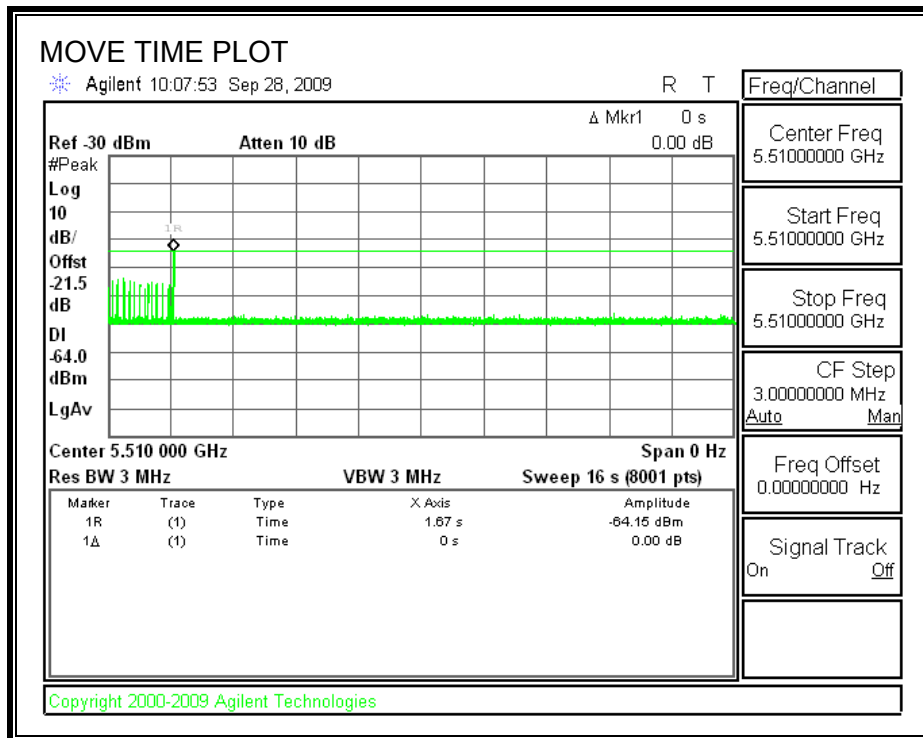

CHANNEL CLOSING TIME

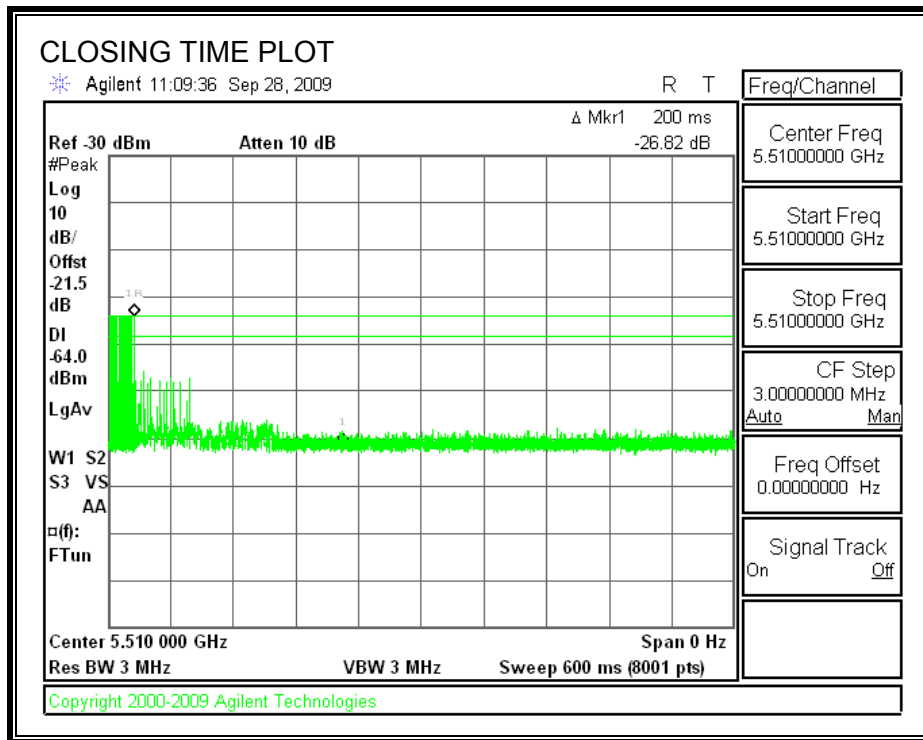

AGGREGATE CHANNEL CLOSING TRANSMISSION TIME

No transmissions are observed during the FCC aggregate monitoring period.

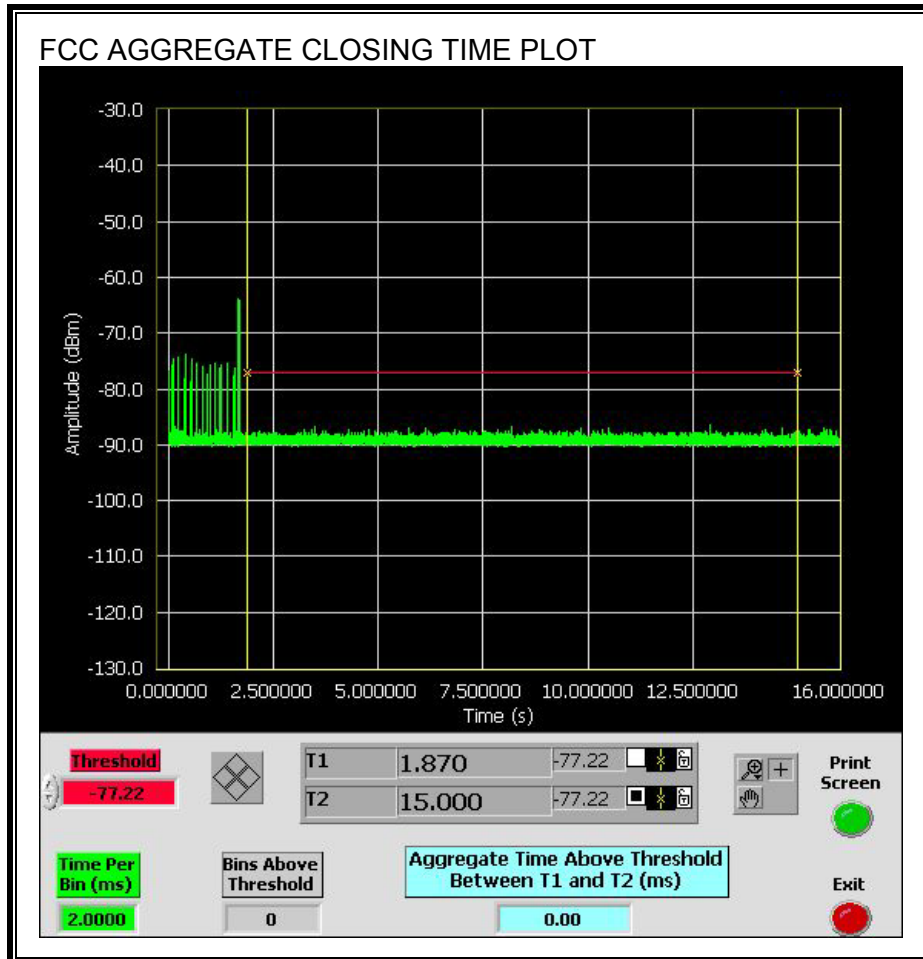

No transmissions are observed during the IC aggregate monitoring period.

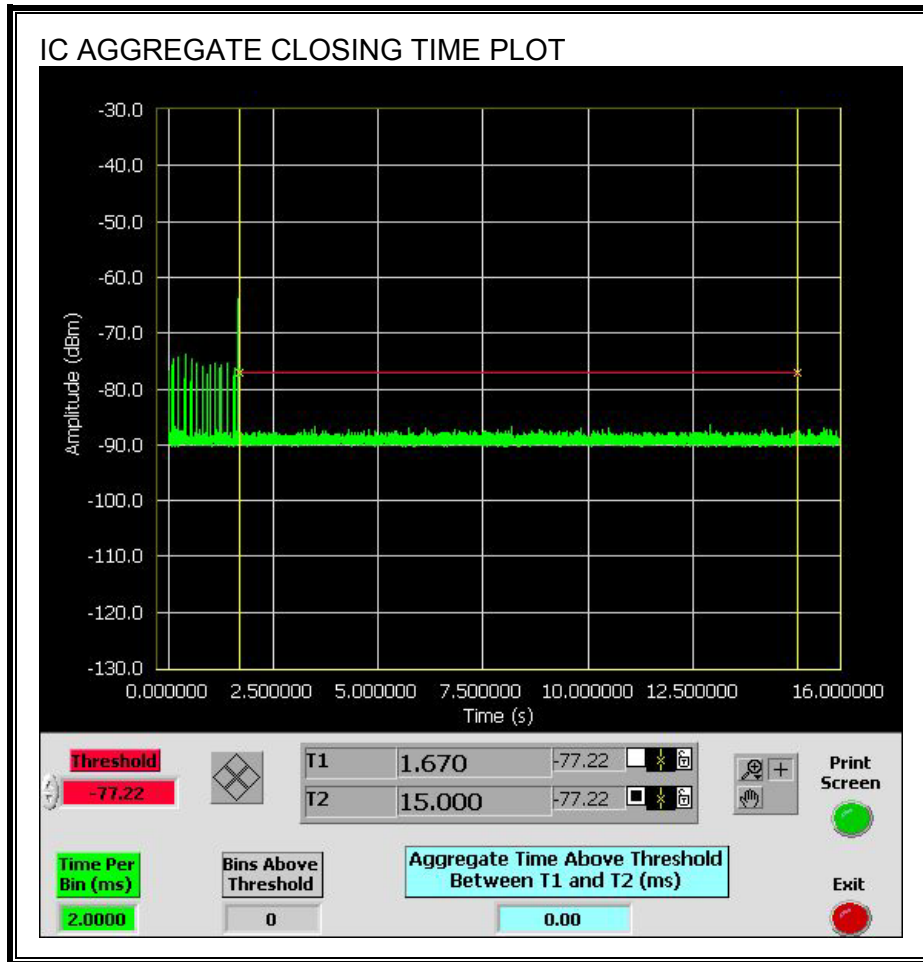

10.3.4. SLAVE NON-OCCUPANCY

TEST RESULTS

No EUT transmissions were observed on the test channel during the 30-minute observation time.

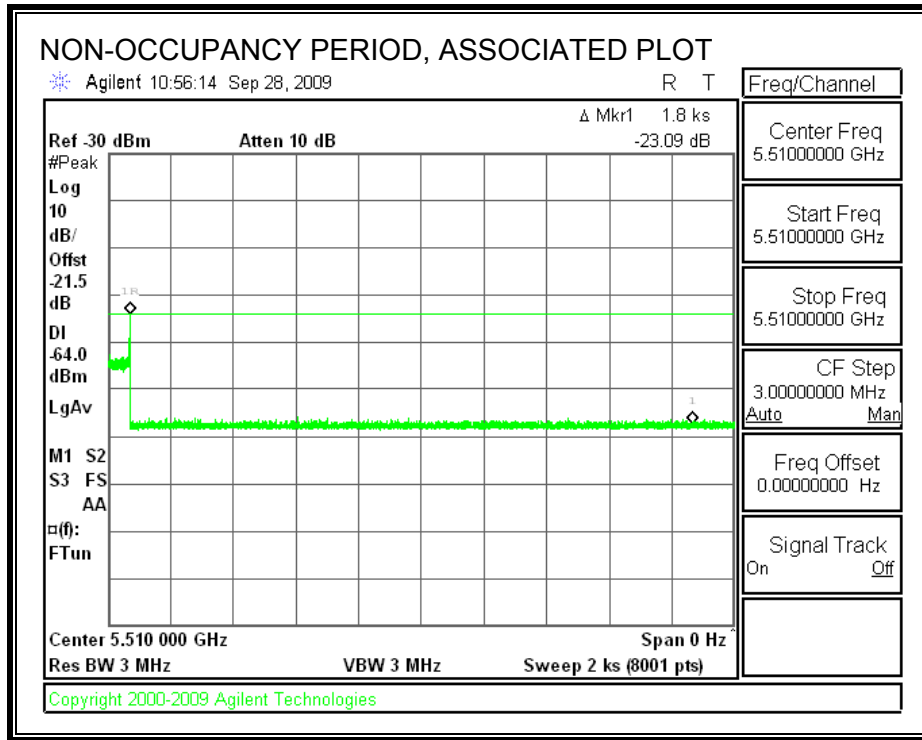

11. MAXIMUM PERMISSIBLE EXPOSURE

FCC RULES

§1.1310 The criteria listed in Table 1 shall be used to evaluate the environmental impact of human exposure to radio-frequency (RF) radiation as specified in §1.1307(b), except in the case of portable devices which shall be evaluated according to the provisions of §2.1093 of this chapter.

TABLE 1—LIMITS FOR MAXIMUM PERMISSIBLE EXPOSURE (MPE)

Frequency range (MHz)	Electric field strength (V/m)	Magnetic field strength (A/m)	Power density (mW/cm ²)	Averaging time (minutes)
(A) Limits for Occupational/Controlled Exposures				
0.3–3.0	614	1.63	*(100)	6
3.0–30	1842/f	4.89/f	*(900/f ²)	6
30–300	61.4	0.163	1.0	6
300–1500	f/300	6
1500–100,000	5	6
(B) Limits for General Population/Uncontrolled Exposure				
0.3–1.34	614	1.63	*(100)	30
1.34–30	824/f	2.19/f	*(180/f ²)	30

TABLE 1—LIMITS FOR MAXIMUM PERMISSIBLE EXPOSURE (MPE)—Continued

Frequency range (MHz)	Electric field strength (V/m)	Magnetic field strength (A/m)	Power density (mW/cm ²)	Averaging time (minutes)
30–300	27.5	0.073	0.2	30
300–1500	f/1500	30
1500–100,000	1.0	30

f = frequency in MHz

* = Plane-wave equivalent power density

NOTE 1 TO TABLE 1: Occupational/controlled limits apply in situations in which persons are exposed as a consequence of their employment provided those persons are fully aware of the potential for exposure and can exercise control over their exposure. Limits for occupational/controlled exposure also apply in situations when an individual is transient through a location where occupational/controlled limits apply provided he or she is made aware of the potential for exposure.

NOTE 2 TO TABLE 1: General population/uncontrolled exposures apply in situations in which the general public may be exposed, or in which persons that are exposed as a consequence of their employment may not be fully aware of the potential for exposure or can not exercise control over their exposure.

IC RULES

IC Safety Code 6, Section 2.2.1 (a) A person other than an RF and microwave exposed worker shall not be exposed to electromagnetic radiation in a frequency band listed in Column 1 of Table 5, if the field strength exceeds the value given in Column 2 or 3 of Table 5, when averaged spatially and over time, or if the power density exceeds the value given in Column 4 of Table 5, when averaged spatially and over time.

**Table 5
 Exposure Limits for Persons Not Classed As RF and Microwave Exposed Workers (Including the General Public)**

1 Frequency (MHz)	2 Electric Field Strength; rms (V/m)	3 Magnetic Field Strength; rms (A/m)	4 Power Density (W/m ²)	5 Averaging Time (min)
0.003–1	280	2.19		6
1–10	280/ <i>f</i>	2.19/ <i>f</i>		6
10–30	28	2.19/ <i>f</i>		6
30–300	28	0.073	2*	6
300–1 500	1.585 <i>f</i> ^{0.5}	0.0042 <i>f</i> ^{0.5}	<i>f</i> /150	6
1 500–15 000	61.4	0.163	10	6
15 000–150 000	61.4	0.163	10	616 000 / <i>f</i> ^{1.2}
150 000–300 000	0.158 <i>f</i> ^{0.5}	4.21 x 10 ⁻⁴ <i>f</i> ^{0.5}	6.67 x 10 ⁻⁵ <i>f</i>	616 000 / <i>f</i> ^{1.2}

* Power density limit is applicable at frequencies greater than 100 MHz.

- Notes:**
1. Frequency, *f*, is in MHz.
 2. A power density of 10 W/m² is equivalent to 1 mW/cm².
 3. A magnetic field strength of 1 A/m corresponds to 1.257 microtesla (μT) or 12.57 milligauss (mG).

EQUATIONS

Power density is given by:

$$S = \text{EIRP} / (4 * \text{Pi} * \text{D}^2)$$

where

S = Power density in W/m²

EIRP = Equivalent Isotropic Radiated Power in W

D = Separation distance in m

Power density in units of W/m² is converted to units of mWc/m² by dividing by 10.

Distance is given by:

$$D = \text{SQRT} (\text{EIRP} / (4 * \text{Pi} * S))$$

where

D = Separation distance in m

EIRP = Equivalent Isotropic Radiated Power in W

S = Power density in W/m²

In the table(s) below, Power and Gain are entered in units of dBm and dBi respectively and conversions to linear forms are used for the calculations.

LIMITS

From FCC §1.1310 Table 1 (B), the maximum value of S = 1.0 mW/cm²

From IC Safety Code 6, Section 2.2 Table 5 Column 4, S = 10 W/m²

RESULTS

(MPE distance equals 20 cm)

Band	Mode	Separation Distance (m)	Output Power (dBm)	Antenna Gain (dBi)	IC Power Density (W/m ²)	FCC Power Density (mW/cm ²)
5.2 GHz	11a (2 Chains)	0.20	12.18	6.01	0.13	0.013
5.2 GHz	11n HT20 (4 Chains)	0.20	13.23	3.0	0.08	0.008
5.2 GHz	11n HT40 (4 Chains)	0.20	16.67	3.0	0.18	0.018
5.3 GHz	11a (2 Chains)	0.20	19.15	6.01	0.65	0.065
5.3 GHz	11n HT20 (4 Chains)	0.20	20.65	3.0	0.46	0.046
5.3 GHz	11n HT40 (4 Chains)	0.20	23.24	3.0	0.84	0.084
5.6 GHz	11a (2 Chains)	0.20	20.77	6.01	0.95	0.095
5.6 GHz	11n HT20 (4 Chains)	0.20	20.24	3.0	0.42	0.042
5.6 GHz	11n HT40 (4 Chains)	0.20	23.65	3.0	0.92	0.092