

TEST REPORT

Test report no.: 1-4938/17-03-06-A



BNetzA-CAB-02/21-102

Testing laboratory

CTC advanced GmbH

Untertuerkheimer Strasse 6 – 10
66117 Saarbruecken / Germany
Phone: + 49 681 5 98 - 0
Fax: + 49 681 5 98 - 9075
Internet: <http://www.ctcadvanced.com>
e-mail: mail@ctcadvanced.com

Accredited Testing Laboratory:

The testing laboratory (area of testing) is accredited according to DIN EN ISO/IEC 17025 (2005) by the Deutsche Akkreditierungsstelle GmbH (DAKKS). The accreditation is valid for the scope of testing procedures as stated in the accreditation certificate with the registration number: D-PL-12076-01-03

Applicant

Marquardt GmbH

Schloss-Str. 16
78604 Rietheim-Weilheim / GERMANY
Phone: +49 7424 99-0
Fax: +49 7424 99-2541
Contact: Mathias Kiefer
e-mail: mathias.kiefer@marquardt.de
Phone: +49 7424 99-28189

Manufacturer

Marquardt GmbH

Schloss-Str. 16
78604 Rietheim-Weilheim / GERMANY

Test standard/s

47 CFR Part 15

Title 47 of the Code of Federal Regulations; Chapter I; Part 15 - Radio frequency devices

For further applied test standards please refer to section 3 of this test report.

Test Item

Kind of test item: Driving authorization system: Vehicle Key
Model name: VK2
FCC ID: IYZVK2
IC: 2701A-VK2
Frequency: 433.47 MHz, 433.92 MHz, 434.37 MHz
Technology tested: Proprietary
Antenna: Integrated antenna
Power supply: 2.55 V to 3.10 V DC by CR2032 battery
Temperature range: -20°C to +70°C



This test report is electronically signed and valid without handwritten signature. For verification of the electronic signatures, the public keys can be requested at the testing laboratory.

Test report authorized:

Christoph Schneider
Lab Manager
Radio Communications & EMC

Test performed:

p.o.
Yves Olsommer
Testing Manager
Radio Communications & EMC

1 Table of contents	
1	Table of contents2
2	General information3
2.1	Notes and disclaimer3
2.2	Application details.....3
2.3	Test laboratories sub-contracted3
3	Test standard/s and references4
4	Test environment.....5
5	Test item5
5.1	General description5
5.2	Additional information5
6	Description of the test setup6
6.1	Shielded semi anechoic chamber7
6.2	Shielded fully anechoic chamber8
6.3	Test setup for normalized measurement configurations9
7	Sequence of testing10
7.1	Sequence of testing radiated spurious 9 kHz to 30 MHz.....10
7.2	Sequence of testing radiated spurious 30 MHz to 1 GHz.....11
7.3	Sequence of testing radiated spurious 1 GHz to 7 GHz12
8	Measurement uncertainty13
9	Summary of measurement results14
9.1	Additional comments14
10	Measurement results15
10.1	Timing of the transmitter15
10.2	Switch off time17
10.3	Emission bandwidth19
10.4	Field strength of the fundamental23
10.5	Field strength of the harmonics and spurious24
10.6	Receiver spurious emission35
11	Observations38
Annex A	Glossary39
Annex B	Document history40
Annex C	Accreditation Certificate40

2 General information

2.1 Notes and disclaimer

The test results of this test report relate exclusively to the test item specified in this test report. CTC advanced GmbH does not assume responsibility for any conclusions and generalizations drawn from the test results with regard to other specimens or samples of the type of the equipment represented by the test item.

The test report may only be reproduced or published in full. Reproduction or publication of extracts from the report requires the prior written approval of CTC advanced GmbH.

The testing service provided by CTC advanced GmbH has been rendered under the current "General Terms and Conditions for CTC advanced GmbH".

CTC advanced GmbH will not be liable for any loss or damage resulting from false, inaccurate, inappropriate or incomplete product information provided by the customer.

Under no circumstances does the CTC advanced GmbH test report include any endorsement or warranty regarding the functionality, quality or performance of any other product or service provided.

Under no circumstances does the CTC advanced GmbH test report include or imply any product or service warranties from CTC advanced GmbH, including, without limitation, any implied warranties of merchantability, fitness for purpose, or non-infringement, all of which are expressly disclaimed by CTC advanced GmbH.

All rights and remedies regarding vendor's products and services for which CTC advanced GmbH has prepared this test report shall be provided by the party offering such products or services and not by CTC advanced GmbH. In no case this test report can be considered as a Letter of Approval.

This test report is electronically signed and valid without handwritten signature. For verification of the electronic signatures, the public keys can be requested at the testing laboratory.

This test report replaces the test report with the number 1-4938/17-03-06 and dated 2018-04-13.

2.2 Application details

Date of receipt of order:	2017-09-07
Date of receipt of test item:	2018-01-11
Start of test:	2018-01-25
End of test:	2018-04-10
Person(s) present during the test:	-/-

2.3 Test laboratories sub-contracted

None

3 Test standard/s and references

Test standard	Date	Description
47 CFR Part 15		Title 47 of the Code of Federal Regulations; Chapter I; Part 15 - Radio frequency devices

Guidance	Version	Description
ANSI C63.4-2014	-/-	American national standard for methods of measurement of radio-noise emissions from low-voltage electrical and electronic equipment in the range of 9 kHz to 40 GHz
ANSI C63.10-2013	-/-	American national standard of procedures for compliance testing of unlicensed wireless devices

4 Test environment

Temperature	:	T_{nom} +22 °C during room temperature tests T_{max} +70 no tests under extreme conditions required T_{min} -20 no tests under extreme conditions required
Relative humidity content	:	42 %
Barometric pressure	:	1012 hpa
Power supply	:	V_{nom} 3.00 V DC by CR2032 battery V_{max} 3.10 no tests under extreme conditions required V_{min} 2.55 no tests under extreme conditions required

5 Test item

5.1 General description

Kind of test item	:	Driving authorization system: Vehicle Key
Type identification	:	VK2
HMN	:	-/-
PMN	:	VK2
HVIN	:	VK2
FVIN	:	-/-
S/N serial number	:	-/-
HW hardware status	:	-/-
SW software status	:	-/-
Frequency	:	433.47 MHz, 433.92 MHz, 434.37 MHz
Type of radio transmission	:	Modulated carrier
Use of frequency spectrum	:	
Type of modulation	:	2-FSK
Number of channels	:	3
Antenna	:	Integrated antenna
Power supply	:	2.55 V to 3.10 V DC by CR2032 battery
Temperature range	:	-20°C to +70°C

5.2 Additional information

The content of the following annexes is defined in the QA. It may be that not all of the listed annexes are necessary for this report, thus some values in between may be missing.

Test setup- and EUT-photos are included in test report:

- 1-4938/17-03-01_AnnexA
- 1-4938/17-03-01_AnnexB
- 1-4938/17-03-01_AnnexD

6 Description of the test setup

Typically, the calibrations of the test apparatus are commissioned to and performed by an accredited calibration laboratory. The calibration intervals are determined in accordance with the DIN EN ISO/IEC 17025. In addition to the external calibrations, the laboratory executes comparison measurements with other calibrated test systems or effective verifications. Weekly chamber inspections and range calibrations are performed. Where possible, RF generating and signaling equipment as well as measuring receivers and analyzers are connected to an external high-precision 10 MHz reference (GPS-based or rubidium frequency standard).

In order to simplify the identification of the equipment used at some special tests, some items of test equipment and ancillaries can be provided with an identifier or number in the equipment list below (Lab/Item).

Agenda: Kind of Calibration

k	calibration / calibrated	EK	limited calibration
ne	not required (k, ev, izw, zw not required)	zw	cyclical maintenance (external cyclical maintenance)
ev	periodic self verification	izw	internal cyclical maintenance
Ve	long-term stability recognized	g	blocked for accredited testing
v/k!	Attention: extended calibration interval		
NK!	Attention: not calibrated	*)	next calibration ordered / currently in progress

6.1 Shielded semi anechoic chamber

The radiated measurements are performed in vertical and horizontal plane in the frequency range from 30 MHz to 1 GHz in semi-anechoic chambers. The EUT is positioned on a non-conductive support with a height of 0.80 m above a conductive ground plane that covers the whole chamber. The receiving antennas are conform to specifications ANSI C63. These antennas can be moved over the height range between 1.0 m and 4.0 m in order to search for maximum field strength emitted from EUT. The measurement distances between EUT and receiving antennas are indicated in the test setups for the various frequency ranges. For each measurement, the EUT is rotated in all three axes until the maximum field strength is received. The wanted and unwanted emissions are received by spectrum analyzers where the detector modes and resolution bandwidths over various frequency ranges are set according to requirement ANSI C63.

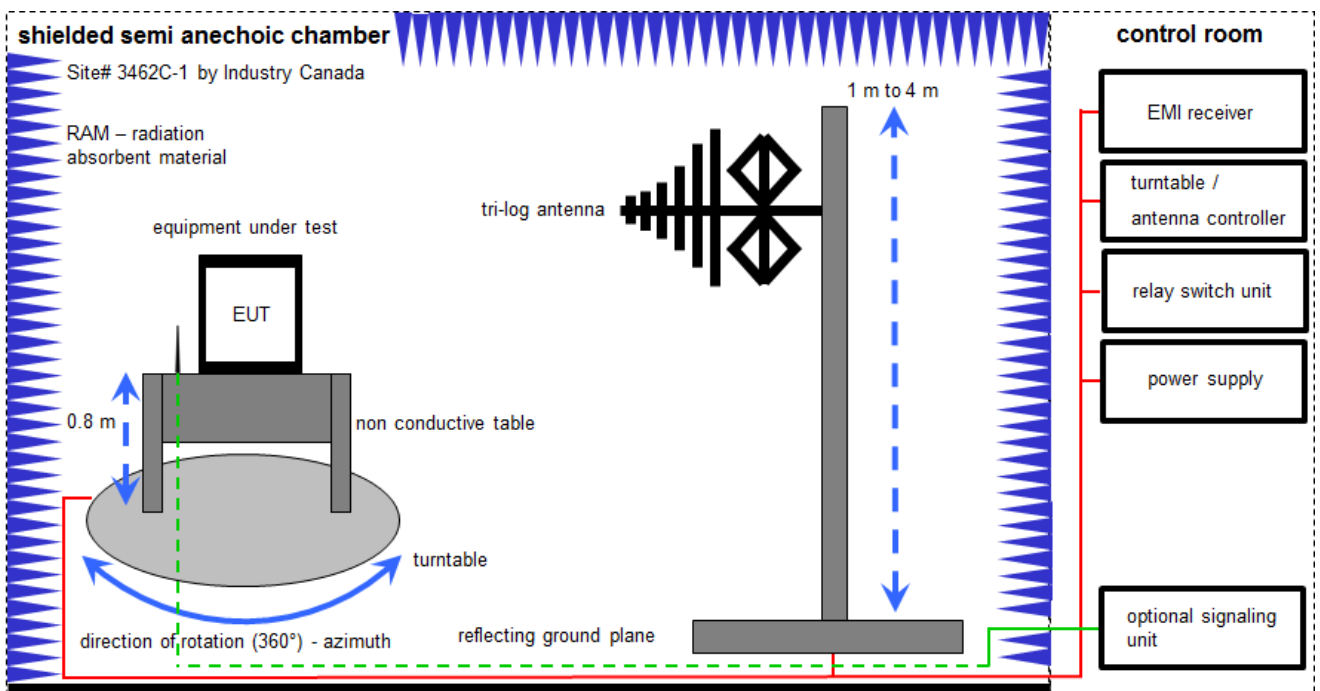

Measurement distance: tri-log antenna 10 meter

$$FS = UR + CL + AF$$

(FS-field strength; UR-voltage at the receiver; CL-loss of the cable; AF-antenna factor)

Example calculation:

$$FS [dB\mu V/m] = 12.35 [dB\mu V/m] + 1.90 [dB] + 16.80 [dB/m] = 31.05 [dB\mu V/m] (35.69 \mu V/m)$$

Equipment table:

No.	Lab / Item	Equipment	Type	Manufacturer	Serial No.	INV. No.	Kind of Calibration	Last Calibration	Next Calibration
1	A	Switch-Unit	3488A	HP	2719A14505	300000368	ev	-/-	-/-
2	A	Meßkabine 1	HF-Absorberhalle	MWB AG 300023	-/-	300000551	ne	-/-	-/-
3	A	EMI Test Receiver	ESCI 3	R&S	100083	300003312	k	15.12.2017	14.12.2018
4	A	Antenna Tower	Model 2175	ETS-Lindgren	64762	300003745	izw	-/-	-/-
5	A	Positioning Controller	Model 2090	ETS-Lindgren	64672	300003746	izw	-/-	-/-
6	A	TRILOG Broadband Test-Antenna 30 MHz - 3 GHz	VULB9163	Schwarzbeck	295	300003787	k	25.04.2016	25.04.2018

6.2 Shielded fully anechoic chamber

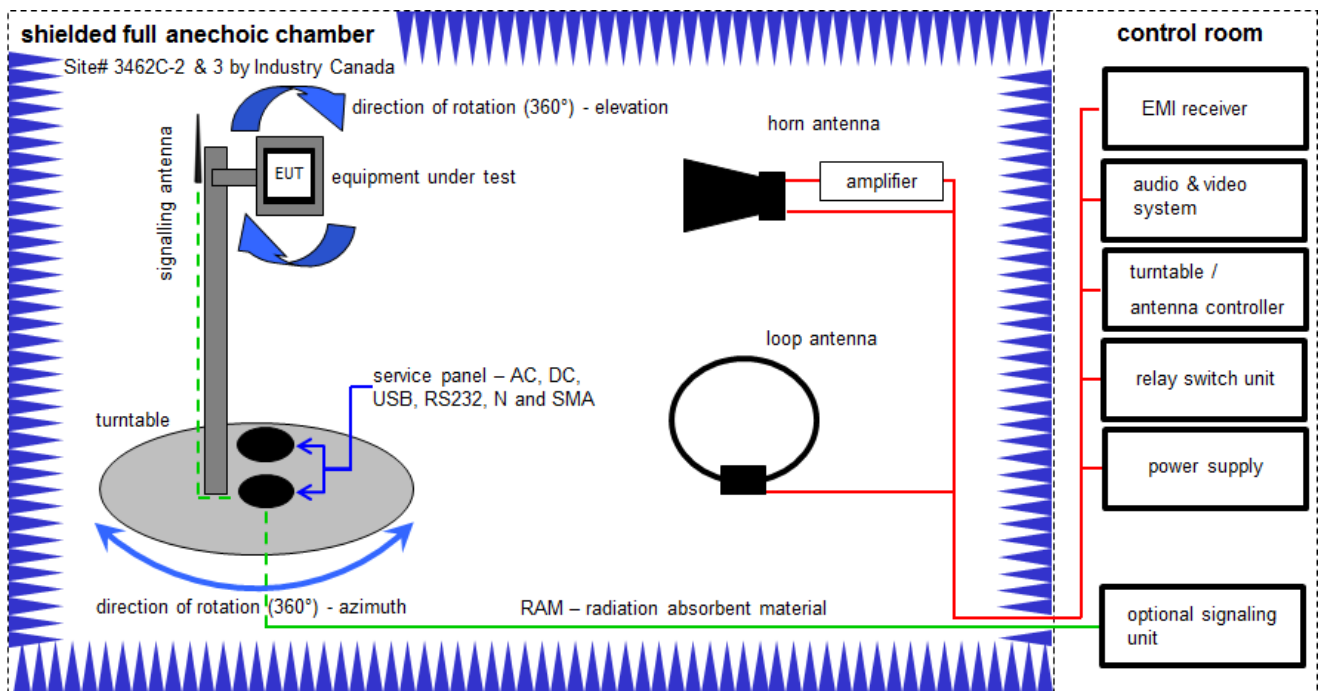

Measurement distance: horn antenna 3 meter; loop antenna 3 meter

$$OP = AV + D - G + CA$$

(OP-radiated output power; AV-analyzer value; D-free field attenuation of measurement distance; G-antenna gain+amplifier gain; CA-loss signal path)

Example calculation:

$$OP \text{ [dBm]} = -39.0 \text{ [dBm]} + 57.0 \text{ [dB]} - 12.0 \text{ [dBi]} + (-36.0) \text{ [dB]} = -30 \text{ [dBm]} (1 \mu\text{W})$$

Equipment table:

No.	Lab / Item	Equipment	Type	Manufacturer	Serial No.	INV. No.	Kind of Calibration	Last Calibration	Next Calibration
1	A	Active Loop Antenna 9 kHz to 30 MHz	6502	EMCO	2210	300001015	k	07.07.2017	06.07.2019
2	A, B	Anechoic chamber	FAC 3/5m	MWB / TDK	87400/02	300000996	ev	-/-	-/-
3	B	Double-Ridged Waveguide Horn Antenna 1-18.0GHz	3115	EMCO	9107-3697	300001605	vKI!	14.02.2017	13.02.2019
4	A, B	Switch / Control Unit	3488A	HP	-/-	300000199	ne	-/-	-/-
5	A, B	EMI Test Receiver 20Hz- 26,5GHz	ESU26	R&S	100037	300003555	k	20.12.2017	19.12.2018
6	B	Broadband Amplifier 0.5-18 GHz	CBLU5184540	CERNEX	22049	300004481	ev	-/-	-/-
7	A, B	4U RF Switch Platform	L4491A	Agilent Technologies	MY50000037	300004509	ne	-/-	-/-
8	A, B	NEXIO EMV- Software	BAT EMC V3.16.0.49	EMCO	-/-	300004682	ne	-/-	-/-
9	A, B	PC	ExOne	F+W	-/-	300004703	ne	-/-	-/-

6.3 Test setup for normalized measurement configurations

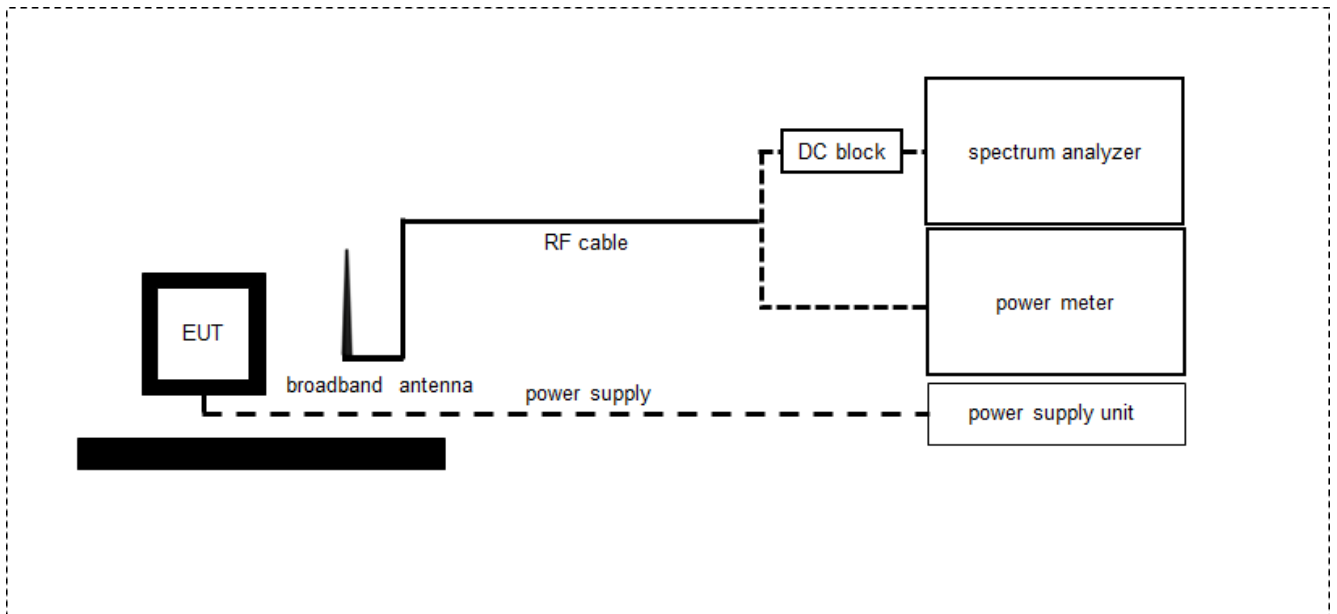

OP = AV + CA
(OP-output power; AV-analyzer value; CA-loss signal path)

Example calculation:

OP [dBm] = 6.0 [dBm] + 11.7 [dB] = 17.7 [dBm] (58.88 mW)

Equipment table:

No.	Lab / Item	Equipment	Type	Manufacturer	Serial No.	INV. No.	Kind of Calibration	Last Calibration	Next Calibration
1	B	Signal- and Spectrum Analyzer	FSW26	R&S	101455	300004528	k	20.12.2017	19.12.2018

7 Sequence of testing

7.1 Sequence of testing radiated spurious 9 kHz to 30 MHz

Setup

- The equipment is set up to simulate normal operation mode as described in the user manual or defined by the manufacturer.
- If the EUT is a tabletop system, it is placed on a table with 0.8 m height.
- If the EUT is a floor standing device, it is placed directly on the turn table.
- Auxiliary equipment and cables are positioned to simulate normal operation conditions as described in ANSI C 63.4.
- The AC power port of the EUT (if available) is connected to a power outlet below the turntable.
- Measurement distance is 3 m (see ANSI C 63.4) – see test details.
- EUT is set into operation.

Premeasurement*

- The turntable rotates from 0° to 315° using 45° steps.
- The antenna height is 1 m.
- At each turntable position the analyzer sweeps with positive-peak detector to find the maximum of all emissions.

Final measurement

- Identified emissions during the pre-measurement are maximized by the software by rotating the turntable from 0° to 360°.
- Loop antenna is rotated about its vertical axis for maximum response at each azimuth about the EUT. (For certain applications, the loop antenna plane may also need to be positioned horizontally at the specified distance from the EUT)
- The final measurement is done in the position (turntable and elevation) causing the highest emissions with quasi-peak (as described in ANSI C 63.4).
- Final levels, frequency, measuring time, bandwidth, turntable position, correction factor, margin to the limit and limit will be recorded. A plot with the graph of the premeasurement and the limit is stored.

*)Note: The sequence will be repeated three times with different EUT orientations.

7.2 Sequence of testing radiated spurious 30 MHz to 1 GHz

Setup

- The equipment is set up to simulate normal operation mode as described in the user manual or defined by the manufacturer.
- If the EUT is a tabletop system, a table with 0.8 m height is used, which is placed on the ground plane.
- If the EUT is a floor standing device, it is placed on the ground plane with insulation between both.
- Auxiliary equipment and cables are positioned to simulate normal operation conditions as described in ANSI C 63.4.
- The AC power port of the EUT (if available) is connected to a power outlet below the turntable.
- Measurement distance is 10 m or 3 m (see ANSI C 63.4) – see test details.
- EUT is set into operation.

Premeasurement

- The turntable rotates from 0° to 315° using 45° steps.
- The antenna is polarized vertical and horizontal.
- The antenna height changes from 1 m to 3 m.
- At each turntable position, antenna polarization and height the analyzer sweeps three times in peak to find the maximum of all emissions.

Final measurement

- The final measurement is performed for at least six highest peaks according to the requirements of the ANSI C63.4.
- Based on antenna and turntable positions at which the peak values are measured the software maximize the peaks by changing turntable position $\pm 45^\circ$ and antenna height between 1 and 4 m.
- The final measurement is done with quasi-peak detector (as described in ANSI C 63.4).
- Final levels, frequency, measuring time, bandwidth, antenna height, antenna polarization, turntable angle, correction factor, margin to the limit and limit are recorded. A plot with the graph of the premeasurement with marked maximum final results and the limit is stored.

7.3 Sequence of testing radiated spurious 1 GHz to 7 GHz

Setup

- The equipment is set up to simulate normal operation mode as described in the user manual or defined by the manufacturer.
- If the EUT is a tabletop system, a 2-axis positioner with 1.5 m height is used.
- If the EUT is a floor standing device, it is placed directly on the turn table.
- Auxiliary equipment and cables are positioned to simulate normal operation conditions as described in ANSI C 63.4.
- The AC power port of the EUT (if available) is connected to a power outlet below the turntable.
- Measurement distance is 3 m (see ANSI C 63.4) – see test details.
- EUT is set into operation.

Premeasurement

- The turntable rotates from 0° to 315° using 45° steps.
- The antenna is polarized vertical and horizontal.
- The antenna height is 1.5 m.
- At each turntable position and antenna polarization the analyzer sweeps with positive peak detector to find the maximum of all emissions.

Final measurement

- The final measurement is performed for at least six highest peaks according to the requirements of the ANSI C63.4.
- Based on antenna and turntable positions at which the peak values are measured the software maximizes the peaks by rotating the turntable from 0° to 360°. This measurement is repeated for different EUT-table positions (0° to 150° in 30°-steps) and for both antenna polarizations.
- The final measurement is done in the position (turntable, EUT-table and antenna polarization) causing the highest emissions with Peak and RMS detector (as described in ANSI C 63.4).
- Final levels, frequency, measuring time, bandwidth, turntable position, EUT-table position, antenna polarization, correction factor, margin to the limit and limit are recorded. A plot with the graph of the premeasurement with marked maximum final results and the limit is stored.

8 Measurement uncertainty

Measurement uncertainty	
Test case	Uncertainty
Occupied bandwidth	± used RBW
Field strength of the fundamental	± 3 dB
Field strength of the harmonics and spurious	± 3 dB
Receiver spurious emissions and cabinet radiations	± 3 dB
Conducted limits	± 2.6 dB

9 Summary of measurement results

<input checked="" type="checkbox"/>	No deviations from the technical specifications were ascertained
<input type="checkbox"/>	There were deviations from the technical specifications ascertained
<input type="checkbox"/>	This test report is only a partial test report. The content and verdict of the performed test cases are listed below.

TC Identifier	Description	Verdict	Date	Remark
RF-Testing	CFR Part 15	See table!	2018-04-23	-/-

Test specification clause	Test case	Temperature conditions	Power source voltages	C	NC	NA	NP	Remark
§ 15.35 (c)	Timing of the transmitter (Duty cycle correction factor)	Nominal	Nominal					
§ 15.231 (a) (1)	Switch off time	Nominal	Nominal	<input checked="" type="checkbox"/>	<input type="checkbox"/>	<input type="checkbox"/>	<input type="checkbox"/>	-/-
§ 15.231 (c)	Emission bandwidth	Nominal	Nominal	<input checked="" type="checkbox"/>	<input type="checkbox"/>	<input type="checkbox"/>	<input type="checkbox"/>	-/-
§ 15.231 (b)	Fieldstrength of Fundamental	Nominal	Nominal	<input checked="" type="checkbox"/>	<input type="checkbox"/>	<input type="checkbox"/>	<input type="checkbox"/>	-/-
§ 15.209	Fieldstrength of harmonics and spurious	Nominal	Nominal	<input checked="" type="checkbox"/>	<input type="checkbox"/>	<input type="checkbox"/>	<input type="checkbox"/>	-/-
§ 15.209	Receiver spurious emissions (radiated)	Nominal	Nominal	<input checked="" type="checkbox"/>	<input type="checkbox"/>	<input type="checkbox"/>	<input type="checkbox"/>	-/-

Note: C = Compliant; NC = Not compliant; NA = Not applicable; NP = Not performed

9.1 Additional comments

Reference documents: None

Special test descriptions: None

Configuration descriptions: None

10 Measurement results

10.1 Timing of the transmitter

Measurement:

Measurement parameter	
Detector:	Peak
Sweep time:	5 s
Resolution bandwidth:	10 Hz
Video bandwidth:	30 Hz
Span:	Zero
Trace-Mode:	Single sweep
Test setup	See chapter 6.3 A
Measurement uncertainty	See chapter 8

Limits:

FCC
(c) Unless otherwise specified, e.g. Section 15.255(b), when the radiated emission limits are expressed in terms of the average value of the emission, and pulsed operation is employed, the measurement field strength shall be determined by averaging over one complete pulse train, including blanking intervals, as long as the pulse train does not exceed 0.1 seconds. As an alternative (provided the transmitter operates for longer than 0.1 seconds) or in cases where the pulse train exceeds 0.1 seconds, the measured field strength shall be determined from the average absolute voltage during a 0.1 second interval during which the field strength is at its maximum value. The exact method of calculating the average field strength shall be submitted with any application for certification or shall be retained in the measurement data file for equipment subject to notification or verification.

Result:

Plot 1: Transmit burst (valid for all channels)

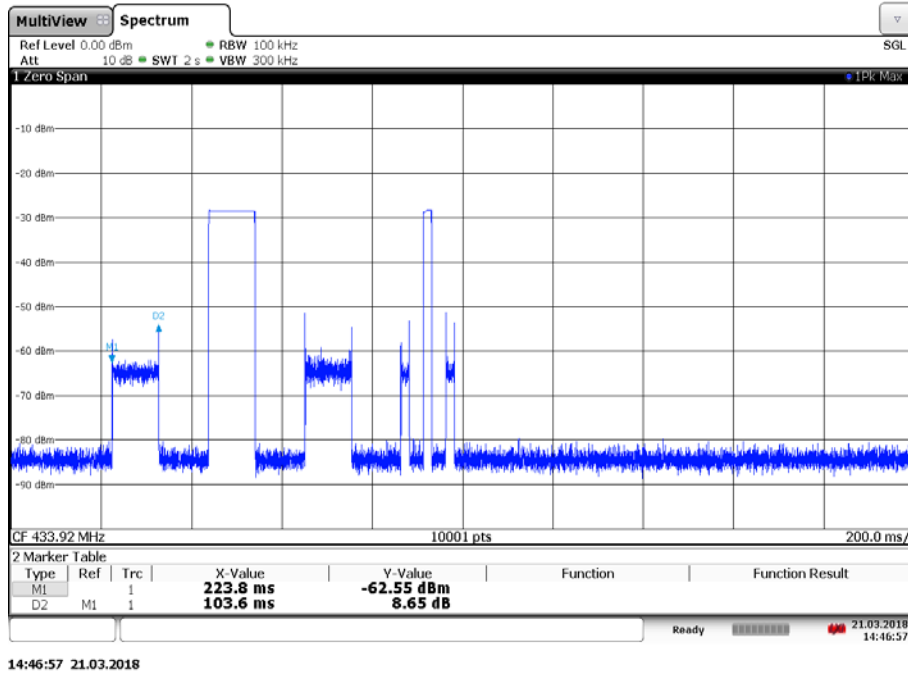

Transmit time (Tx on) = > 100 ms (103.6 ms) (Plot 1)
 Tx on + Tx off = 100 ms (Plot 1)

The peak-to-average correction factor is calculated with $20\text{Log} [\text{Tx on}/(\text{Tx on} + \text{Tx off})]$.
 Hereby the peak-to-average correction factor is 0 dB

10.2 Switch off time

Measurement:

Measurement parameter	
Detector:	Peak
Sweep time:	10 s
Resolution bandwidth:	1 MHz
Video bandwidth:	3 MHz
Span:	Zero
Trace-Mode:	Single sweep
Test setup	See chapter 6.3 A
Measurement uncertainty	See chapter 8

Limits:

FCC
A manually operated transmitter shall employ a switch that will automatically deactivate the transmitter within not more than 5 seconds of being released.

Results:

Plot 1: TX on time (valid for all channels)

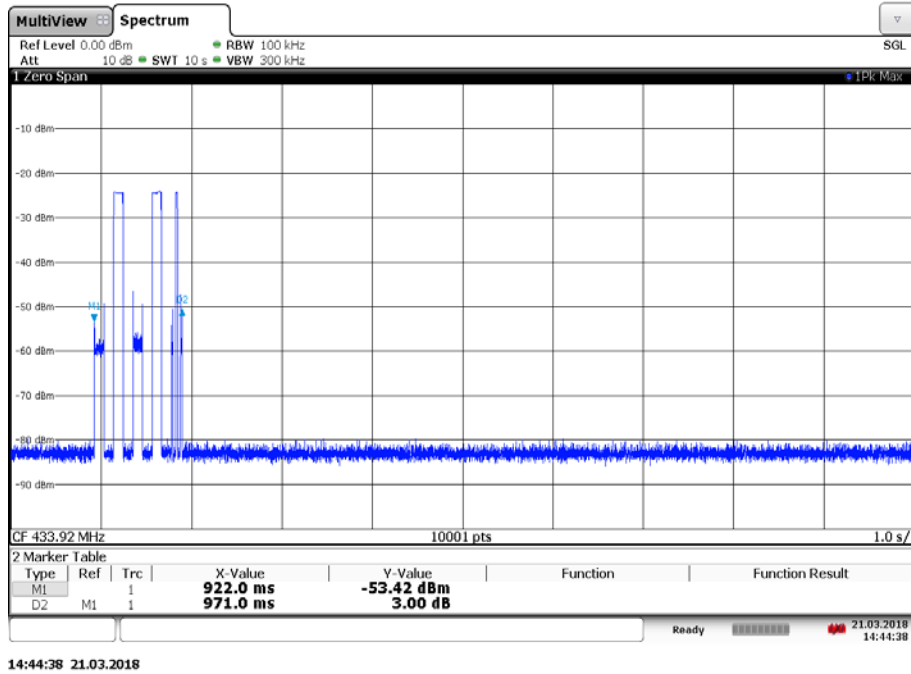

The EUT automatically ceases transmission within 971 ms after releasing the switch.

10.3 Emission bandwidth

Measurement:

Measurement of the 99 % bandwidth of the modulated signal

Measurement parameter	
Detector:	Peak
Sweep time:	40 ms
Resolution bandwidth:	1 % of the span
Video bandwidth:	3 x RBW
Span:	300 kHz
Trace-Mode:	Max. hold
Test setup	See chapter 6.3 A
Measurement uncertainty	See chapter 8

Limits:

FCC	
433.47	The OBW shall not be wider than 0.25% of the centre frequency, here maximum 1.083675 MHz
433.92	The OBW shall not be wider than 0.25% of the centre frequency, here maximum 1.084800 MHz
434.37	The OBW shall not be wider than 0.25% of the centre frequency, here maximum 1.085925MHz

Result:

Channel / MHz	Test conditions		Signal bandwidth / kHz	
	Mode		OBW 99%	20 dB-bandwidth
433.47	T _{nom}	V _{nom}	42.1	25.47
433.92	T _{nom}	V _{nom}	55.8	25.47
434.37	T _{nom}	V _{nom}	52.6	25.47

Plots: Emissions bandwidth (99%)

Plot 1: lowest channel

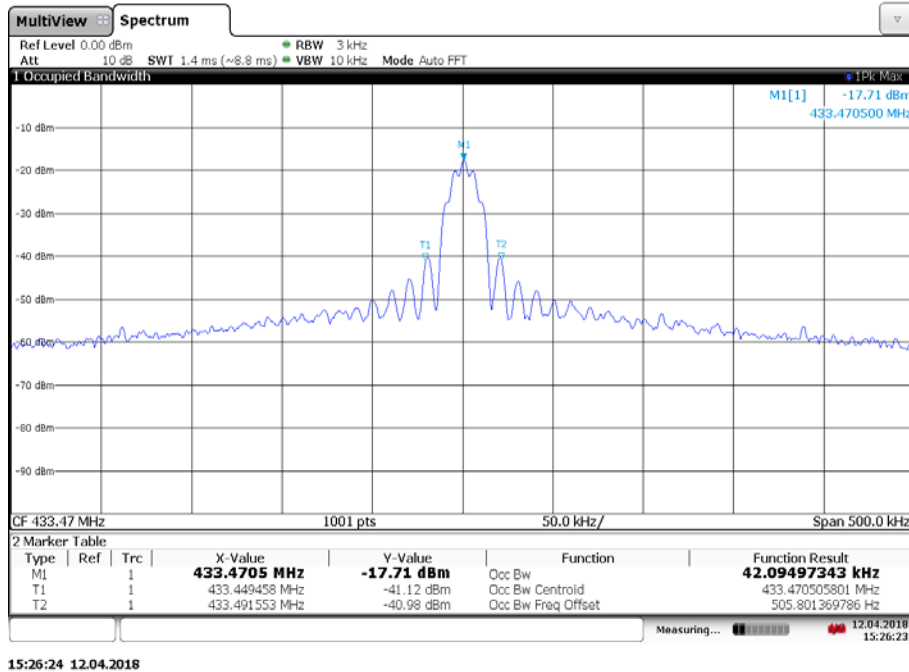

Plot 2: middle channel

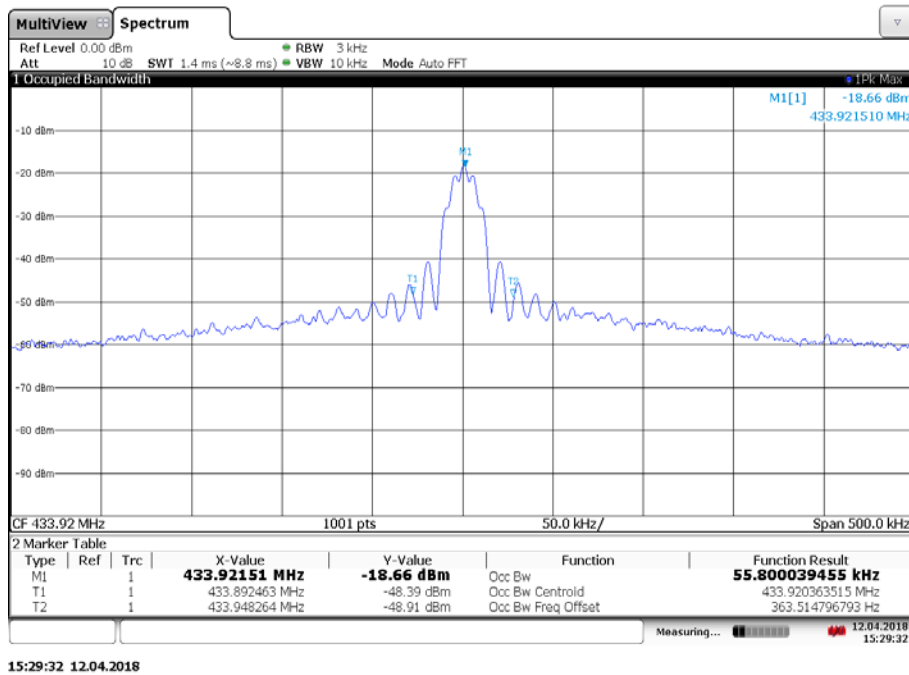

Plot 3: highest channel

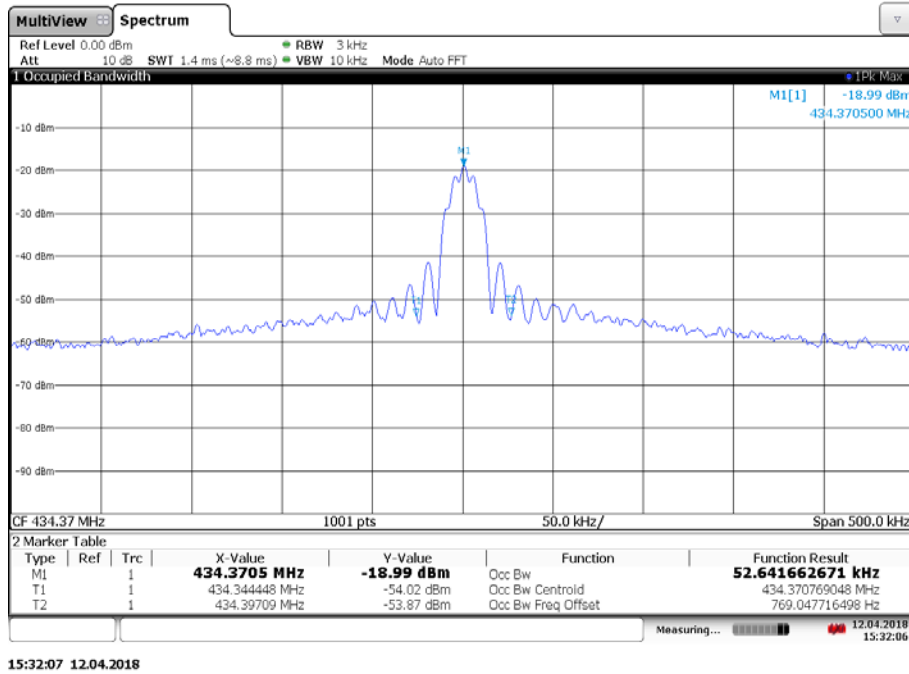

Plots: Emissions bandwidth (20 dB)

Plot 1: lowest channel

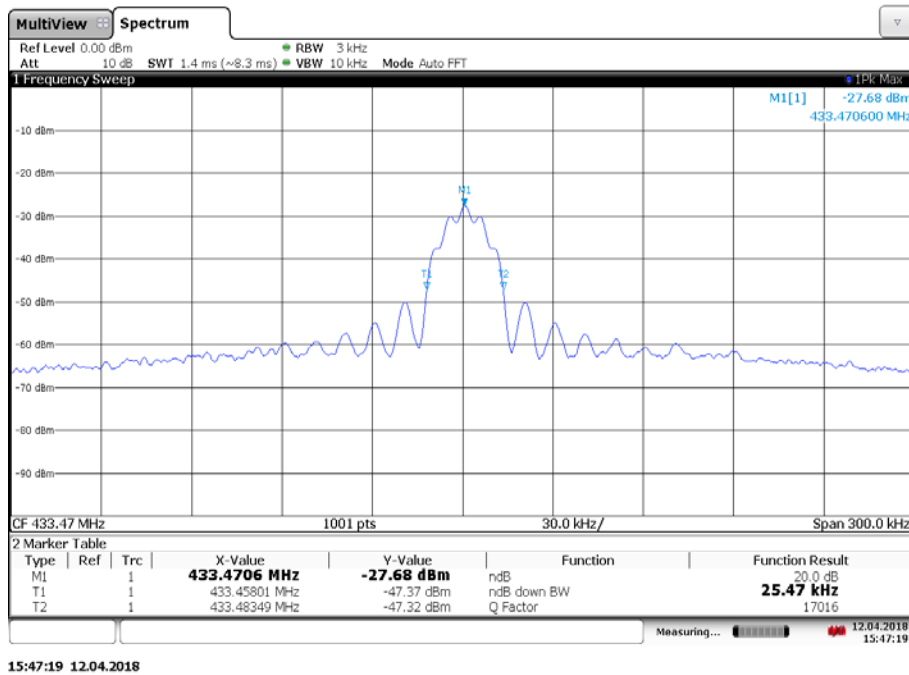

Plot 2: middle channel

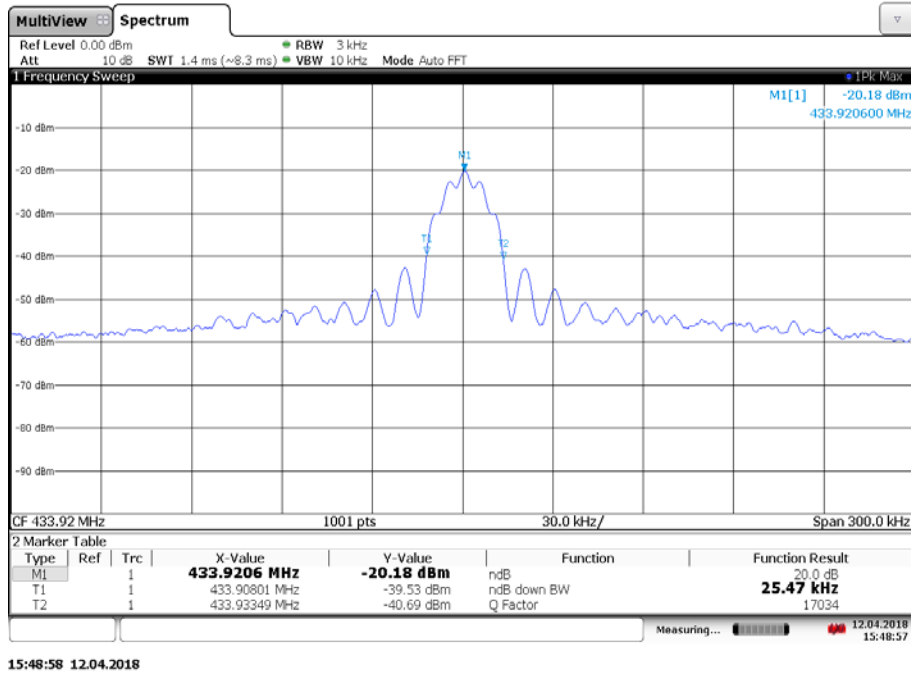

Plot 3: highest channel

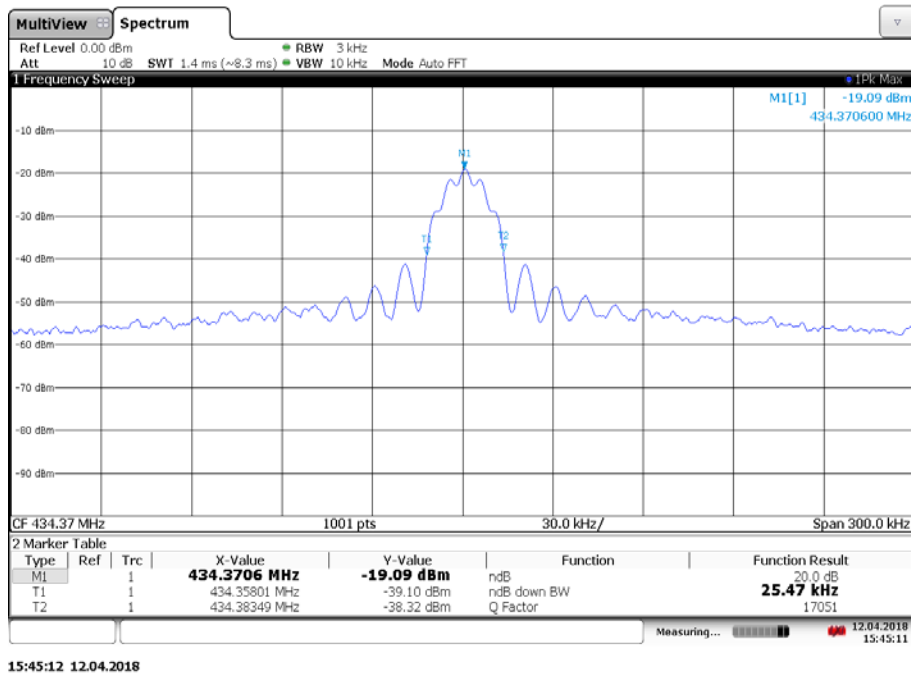

10.4 Field strength of the fundamental

Measurement:

Measurement parameter	
Detector:	Peak / pulse averaging / quasi peak
Sweep time:	Auto
Resolution bandwidth:	120 kHz
Video bandwidth:	3 x RBW
Span:	Depends on the signal
Trace-Mode:	Max. hold
Test setup	See chapter 6.1 A
Measurement uncertainty	See chapter 8

Limits:

FCC		
Field strength of the fundamental. In addition to the provisions of Section 15.205, the field strength of emissions from intentional radiators operated under this Section shall not exceed the following:		
Fundamental Frequency (MHz)	Field strength of Fundamental (µV/m)	Measurement distance (m)
40.66 – 40.70	2,250	3
70-130	1,250	3
130-174	1,250 to 3,750	3
174-260	3,750	3
260-470	3,750 to 12,500	3
Above 470	12,500	3

Where F is the frequency in MHz, the formulas for calculating the maximum permitted fundamental field strengths are as follows:

- for the band 130-174 MHz, µV/m at 3 meters = 56.81818(F) - 6136.3636;
- for the band 260-470 MHz, µV/m at 3 meters = 41.6667(F) - 7083.3333.

Result:

TEST CONDITIONS		MAXIMUM POWER (µV/m at 3 m distance)								
Frequency		433.47 MHz		Limit	433.92 MHz		Limit	434.37 MHz		Limit
Mode		Peak	Average	Average	Peak	Average	Average	Peak	Average	Average
Tnom	Vnom	8580.25	-/*	10,978	8443.06	-/*	10,997	8026.02	-/*	11,015

Peak-to-Average correction factor is 0 dB (see chapter 10.1)

10.5 Field strength of the harmonics and spurious

Measurement:

Measurement parameter	
Detector:	Peak / average / quasi peak
Sweep time:	Auto
Resolution bandwidth:	200 Hz / 9 kHz / 120 kHz
Video bandwidth:	3 x RBW
Span:	See plots
Trace-Mode:	Max. hold
Test setup	See chapter 6.1 A & 6.2 A / B
Measurement uncertainty	See chapter 8

Limits:

FCC		
Field strength of the fundamental. In addition to the provisions of Section 15.205, the field strength of emissions from intentional radiators operated under this Section shall not exceed the following:		
Fundamental Frequency (MHz)	Field strength of spurious ($\mu\text{V/m}$)	Measurement distance (m)
40.66 – 40.70	225	3
70-130	125	3
130-174	125 to 375	3
174-260	375	3
260-470	375 to 1,250	3
Above 470	1,250	3

Spurious emissions shall be attenuated to the average (or, alternatively, CISPR quasi-peak) limits shown in this table or to the general limits shown in Section 15.209, whichever limit permits a higher field strength.

FCC §15.209		
Frequency (MHz)	Field strength ($\mu\text{V/m}$)	Measurement distance (m)
0.009 – 0.490	2400/F(kHz)	300
0.490 – 1.705	24000/F(kHz)	30
1.705 – 30	30	30
30 – 88	100	3
88 – 216	150	3
216 – 960	200	3
above 960	500	3

Results:

Fundamental Frequency	Spurious Frequency	Detector	Limit max. allowed [dB μ V/m]	Amplitude of emission [dB μ V/m]
433.47 MHz	1300 MHz	RMS	54	43.9
433.47 MHz	1733.8 MHz	RMS	54	39.2
433.92 MHz	1301.8 MHz	RMS	54	45.8
434.37 MHz	1303.0 MHz	Peak	54	46.1

Plots: Lowest channel

Plot 1: 9 kHz to 30 MHz

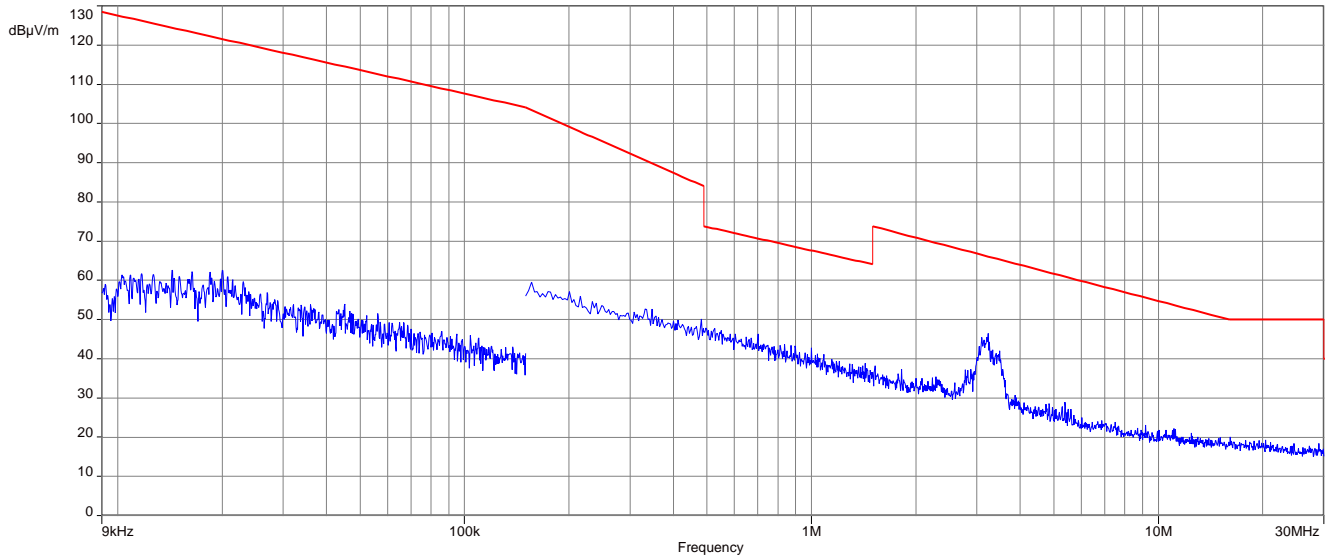

Plot 2: 30 MHz to 1000 MHz, vertical & horizontal polarisation

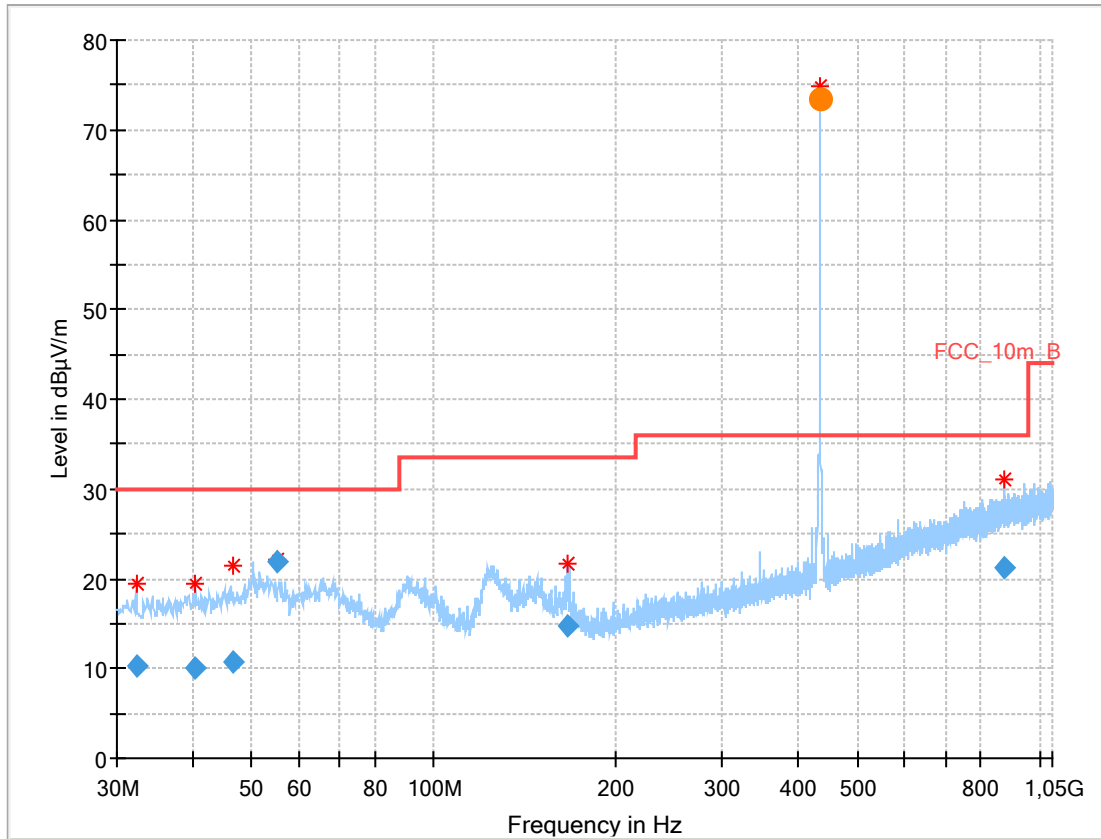

Final_Result

Frequency (MHz)	QuasiPeak (dBµV/m)	Limit (dBµV/m)	Margin (dB)	Meas. Time (ms)	Bandwidth (kHz)	Height (cm)	Pol	Azimuth (deg)	Corr. (dB)
32.278	10.35	30.0	19.65	1000	120	203.0	V	330.0	12.2
40.296	10.05	30.0	19.95	1000	120	203.0	H	60.0	13.2
46.575	10.74	30.0	19.26	1000	120	103.0	V	308.0	13.7
55.225	21.89	30.0	8.11	1000	120	200.0	V	76.0	13.0
166.413	14.83	33.5	18.67	1000	120	100.0	V	165.0	10.1
874.217	21.26	36.0	14.74	1000	120	100.0	V	232.0	23.9

Plot 3: 1000 MHz to 7000 MHz, vertical & horizontal polarisation

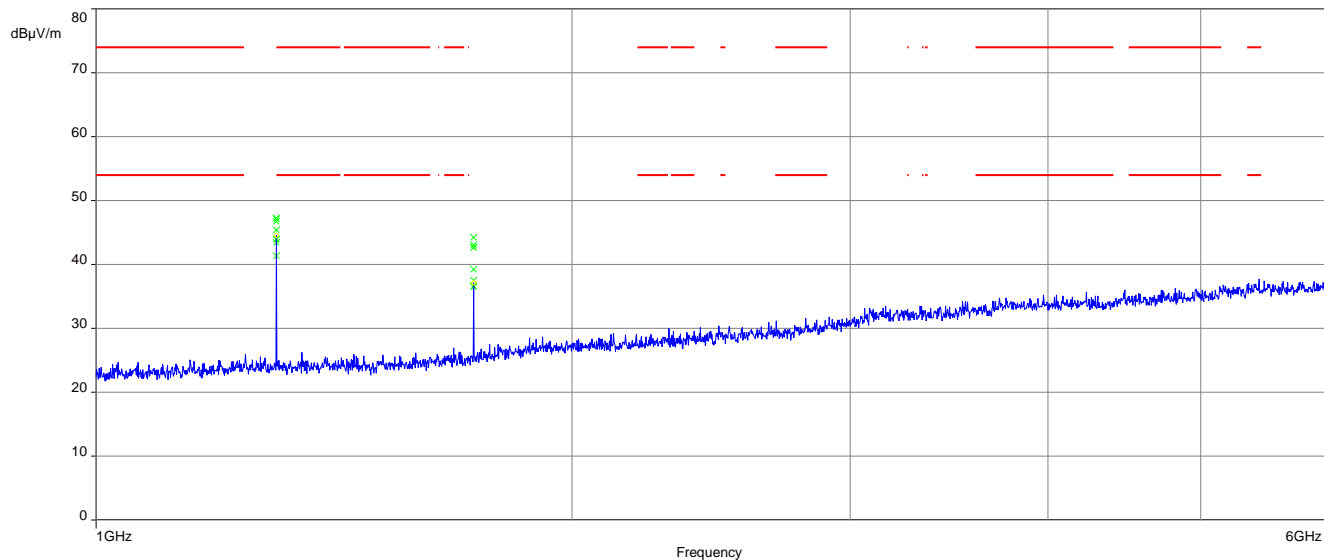

Plots: Middle channel

Plot 1: 9 kHz to 30 MHz

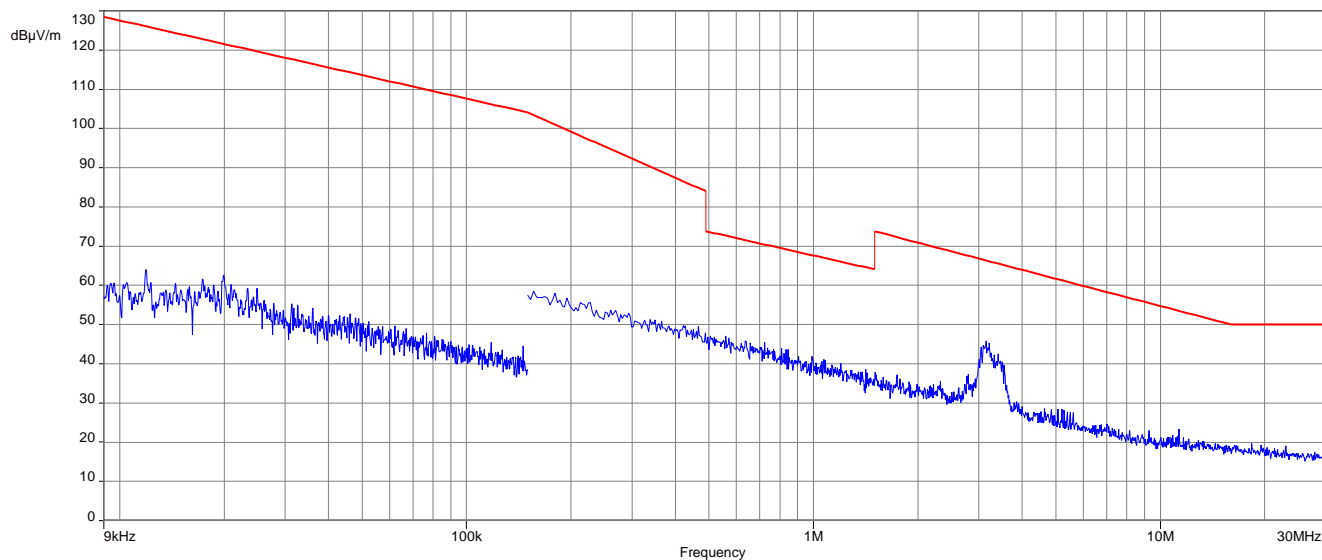

Plot 2: 30 MHz to 1000 MHz, vertical & horizontal polarisation

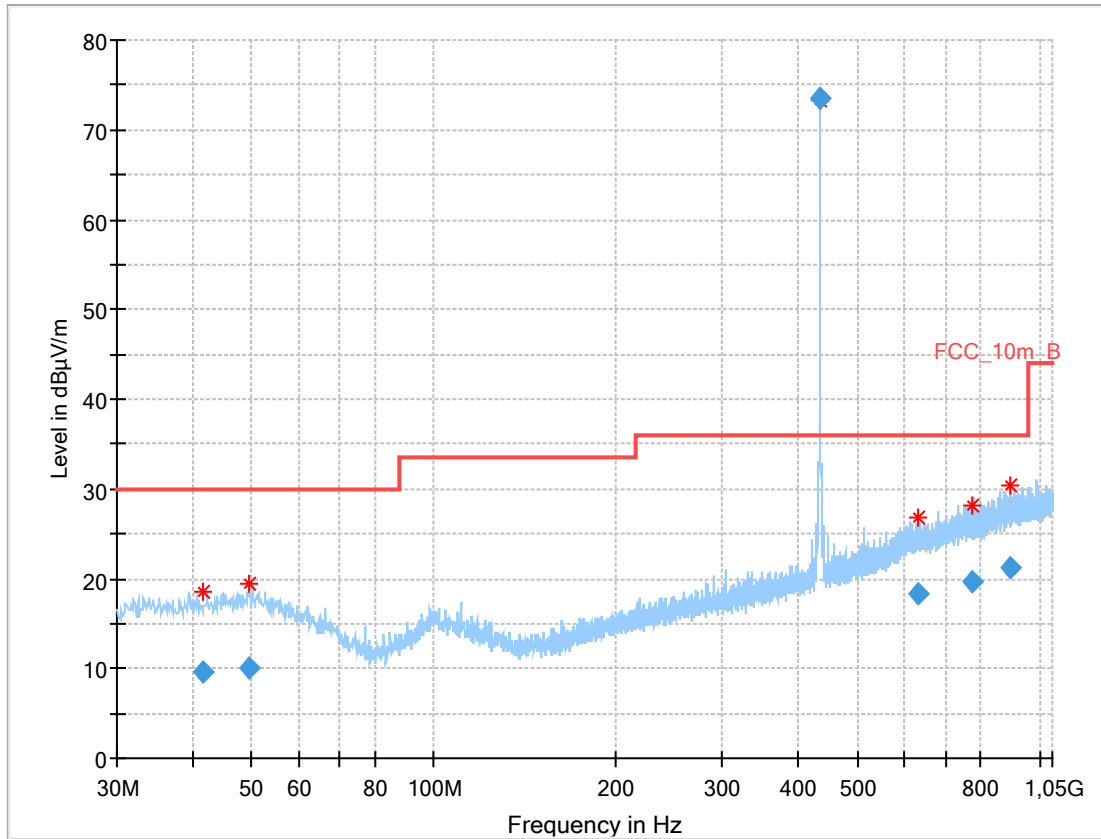

Final_Result

Frequency (MHz)	QuasiPeak (dBµV/m)	Limit (dBµV/m)	Margin (dB)	Meas. Time (ms)	Bandwidth (kHz)	Height (cm)	Pol	Azimuth (deg)	Corr. (dB)
41.712	9.56	30.0	20.44	1000	120	203.0	H	233.0	13.4
49.755	10.16	30.0	19.84	1000	120	203.0	V	8.0	13.7
632.124	18.26	36.0	17.74	1000	120	100.0	H	-15.0	21.0
773.099	19.69	36.0	16.31	1000	120	271.0	V	240.0	22.7
896.213	21.22	36.0	14.78	1000	120	349.0	V	75.0	24.1

Plot 3: 1000 MHz to 7000 MHz, vertical & horizontal polarisation

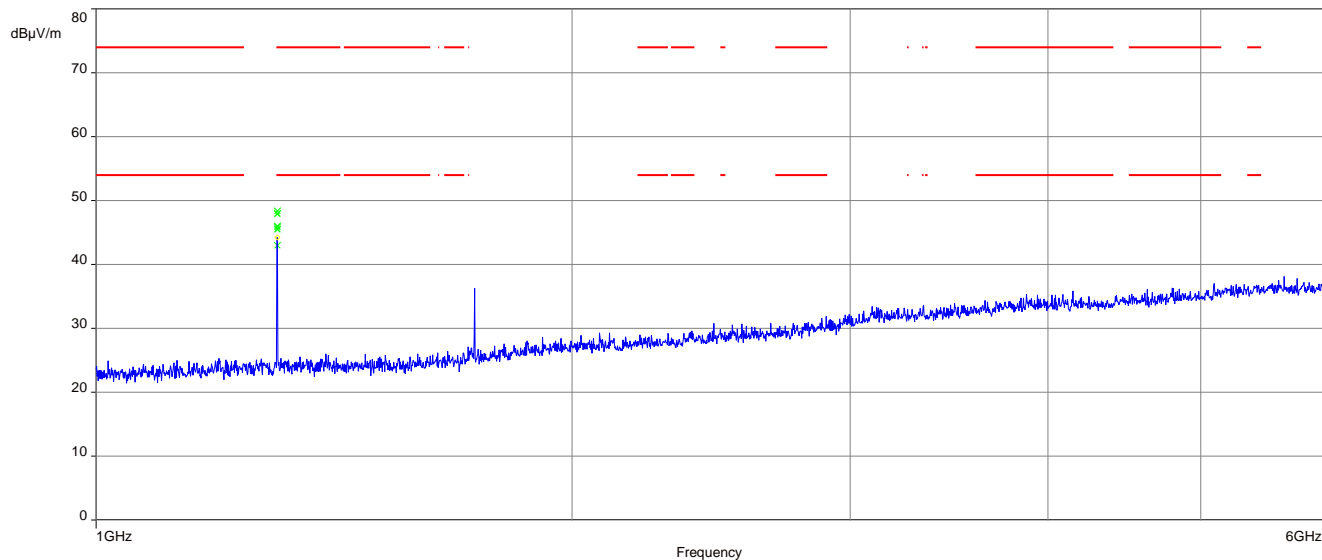

Plots: Highest channel

Plot 1: 9 kHz to 30 MHz

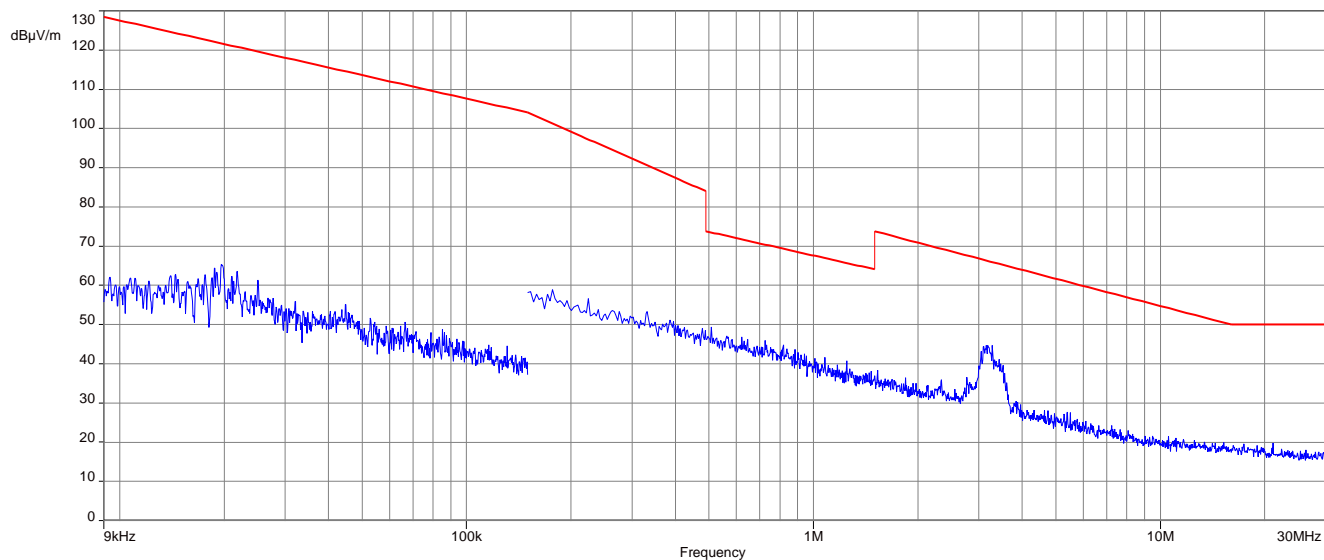

Plot 2: 30 MHz to 1000 MHz, vertical & horizontal polarisation

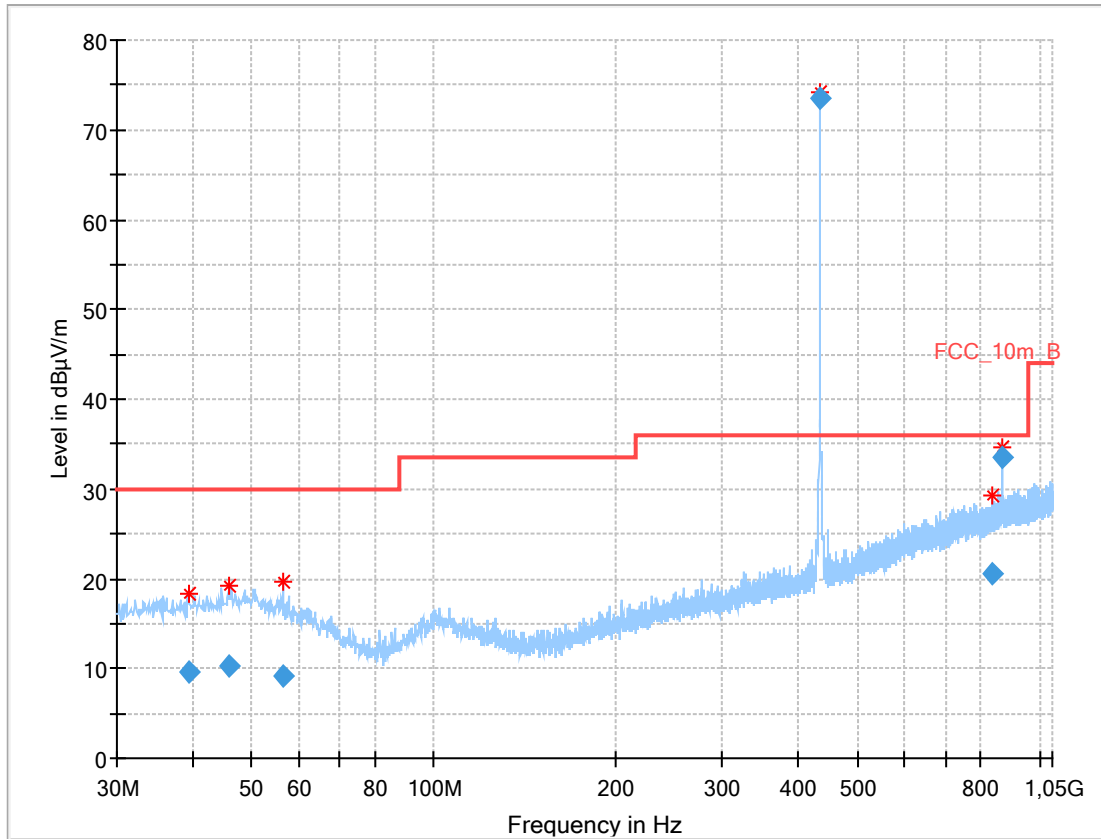

Final_Result

Frequency (MHz)	QuasiPeak (dBµV/m)	Quasi Peak µV/m	Limit (dBµV/m)	Margin (dB)	Meas. Time (ms)	Bandwidth (kHz)	Height (cm)	Pol	Azimuth (deg)	Corr. (dB)
39.598	9.63		30.0	20.37	1000	120	203.0	V	300.0	13.2
45.794	10.29		30.0	19.71	1000	120	203.0	H	128.0	13.6
56.590	9.26		30.0	20.74	1000	120	273.0	H	150.0	12.7
837.823	20.57		36.0	15.43	1000	120	107.0	V	210.0	23.3
868.725	33.44		36.0	2.56	1000	120	100.0	H	30.0	23.8

Plot 3: 1000 MHz to 7000 MHz, vertical & horizontal polarisation

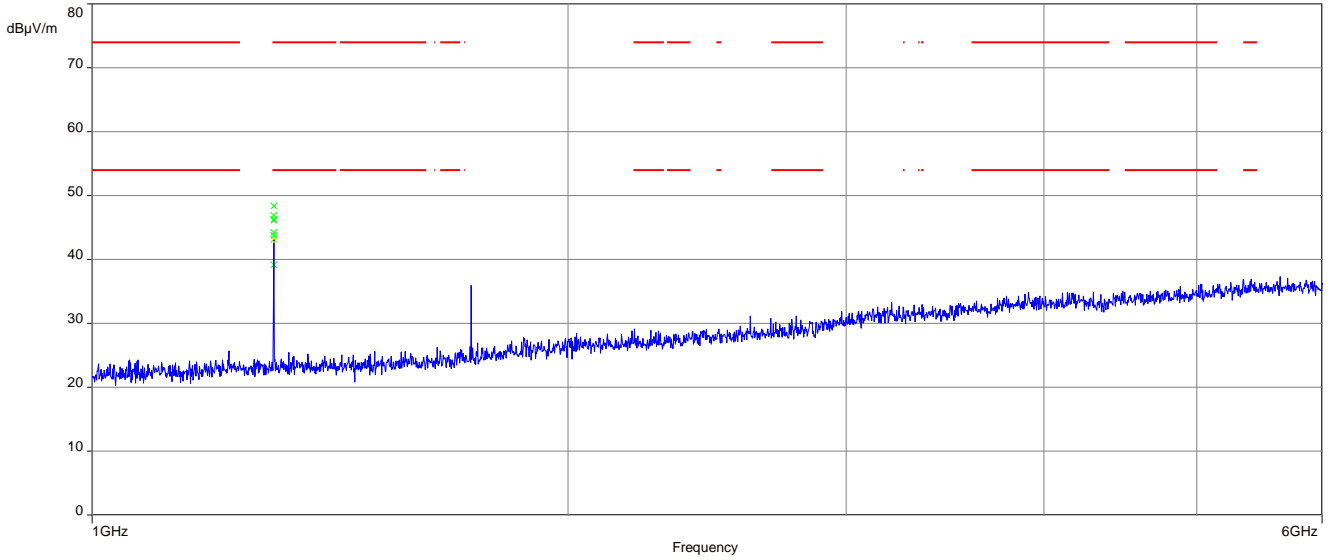

10.6 Receiver spurious emission

Measurement:

Measurement parameter	
Detector:	Peak / average / quasi peak
Sweep time:	Auto
Resolution bandwidth:	120 kHz
Video bandwidth:	3 x RBW
Span:	See plots
Trace mode:	Max. hold
Test setup	See chapter 6.1 A & 6.2 B
Measurement uncertainty	See chapter 8

Limits:

FCC		
Frequency (MHz)	Field strength ($\mu\text{V/m}$)	Measurement distance (m)
30 - 88	100	3
88 - 216	150	3
216 - 960	200	3
above 960	500	3

Results:

Fundamental Frequency	Spurious Frequency	Detector	Limit max. allowed [$\text{dB}\mu\text{V/m}$]	Amplitude of emission [$\text{dB}\mu\text{V/m}$]
No peaks detected.				

Plots:

Plot 1: 30 MHz to 1000 MHz, vertical & horizontal polarisation

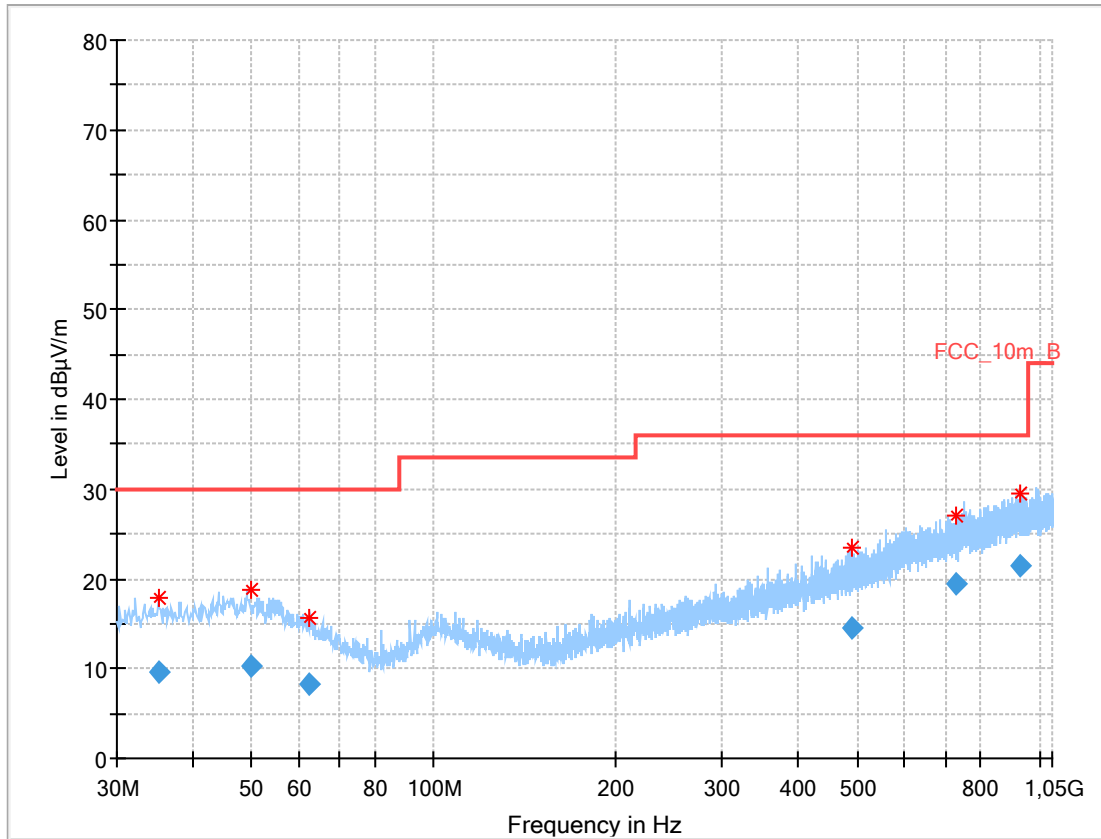

Frequency (MHz)	QuasiPeak (dBµV/m)	Limit (dBµV/m)	Margin (dB)	Meas. Time (ms)	Bandwidth (kHz)	Height (cm)	Pol	Azimuth (deg)	Corr. (dB)
35.319	9.59	30.0	20.41	1000	120	101.0	H	270.0	12.7
49.796	10.21	30.0	19.79	1000	120	170.0	H	0.0	13.7
62.306	8.22	30.0	21.78	1000	120	100.0	V	0.0	11.3
488.646	14.57	36.0	21.43	1000	120	101.0	H	0.0	18.5
728.685	19.55	36.0	16.45	1000	120	170.0	V	180.0	22.2
929.249	21.35	36.0	14.65	1000	120	170.0	V	90.0	24.3

Plot 2: 1000 MHz to 7000 MHz, vertical & horizontal polarisation

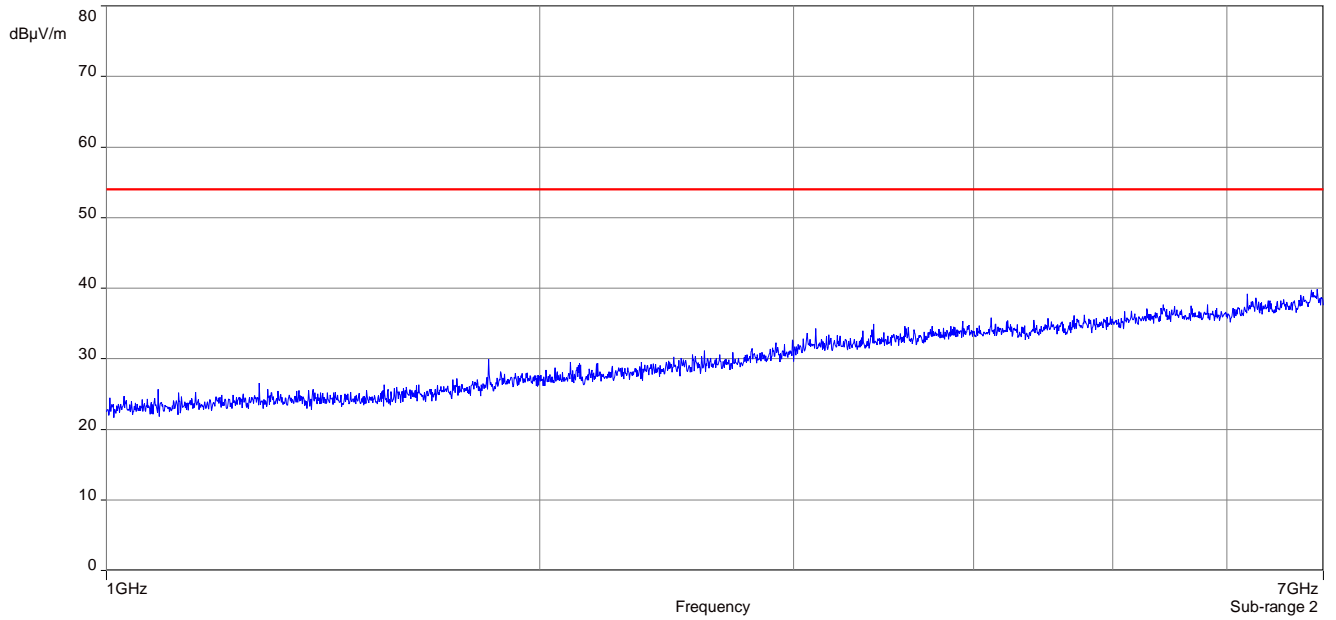

11 Observations

No observations except those reported with the single test cases have been made.

Annex A Glossary

EUT	Equipment under test
DUT	Device under test
UUT	Unit under test
GUE	GNSS User Equipment
ETSI	European Telecommunications Standards Institute
EN	European Standard
FCC	Federal Communications Commission
FCC ID	Company Identifier at FCC
IC	Industry Canada
PMN	Product marketing name
HMN	Host marketing name
HVIN	Hardware version identification number
FVIN	Firmware version identification number
EMC	Electromagnetic Compatibility
HW	Hardware
SW	Software
Inv. No.	Inventory number
S/N or SN	Serial number
C	Compliant
NC	Not compliant
NA	Not applicable
NP	Not performed
PP	Positive peak
QP	Quasi peak
AVG	Average
OC	Operating channel
OCW	Operating channel bandwidth
OBW	Occupied bandwidth
OOB	Out of band
DFS	Dynamic frequency selection
CAC	Channel availability check
OP	Occupancy period
NOP	Non occupancy period
DC	Duty cycle
PER	Packet error rate
CW	Clean wave
MC	Modulated carrier
WLAN	Wireless local area network
RLAN	Radio local area network
DSSS	Dynamic sequence spread spectrum
OFDM	Orthogonal frequency division multiplexing
FHSS	Frequency hopping spread spectrum
GNSS	Global Navigation Satellite System
C/N₀	Carrier to noise-density ratio, expressed in dB-Hz

Annex B Document history

Version	Applied changes	Date of release
-/-	Initial release	2018-04-13
A	Removed IC information	2018-04-23

Annex C Accreditation Certificate

first page	last page
 <p>The first page of the accreditation certificate includes the DAkkS logo, the name 'Deutsche Akkreditierungsstelle GmbH', and accreditation details for CTC advanced GmbH. It states that the laboratory is competent under DIN EN ISO/IEC 17025:2005 for telecommunication tests. A signature of the Head of Division is visible at the bottom.</p>	 <p>The last page of the certificate provides contact information for three offices: Berlin, Frankfurt am Main, and Braunschweig. It also contains a disclaimer about the publication of extracts and information on how to retrieve the up-to-date state of membership.</p>

Note: The current certificate annex is published on the website (link see below) of the Accreditation Body DAkkS or may be received by CTC advanced GmbH on request

<http://www.dakks.de/as/ast/d/D-PL-12076-01-03.pdf>