



LEXMARK INTERNATIONAL

TEST REPORT

for

**FCC PART 15
INDUSTRY CANADA RSS-210**

TRADE NAME: RFID UHF Option

MODEL NUMBER: 4061-RF1

Test Report Number: 621-EMC-2008-FCC-032408

Date: March 24, 2008

1 TABLE OF CONTENTS

1	TABLE OF CONTENTS.....	2
2	TECHNICAL REPORT.....	3
2.1	PURPOSE OF TESTING.....	3
2.2	APPLIED STANDARDS	3
3	SUMMARY	4
4	DESCRIPTION OF EUT.....	5
4.1	EUT PHOTOS.....	5
4.2	EUT ANTENNA.....	8
5	TEST CONFIGURATION	10
6	CABLE INFORMATION	11
7	TESTING & MEASUREMENT EQUIPMENT	11
8	TEST RESULTS.....	12
8.1	20 dB BANDWIDTH.....	12
8.2	HOPPING CHANNEL SEPARATION.....	15
8.3	NUMBER OF HOPPING CHANNEL FREQUENCIES	17
8.4	AVERAGE TIME OF OCCUPANCY	19
8.5	CONDUCTED POWER	24
8.6	OUT OF BAND EMISSIONS AT ANTENNA TERMINALS.....	34
8.7	RADIATED SPURIOUS EMISSIONS	39
8.8	CONDUCTED EMISSIONS	43
8.9	MAXIMUM PERMISSIBLE EXPOSURE CALCULATIONS.....	46

2 TECHNICAL REPORT

Manufacturer of Equipment-under-test	Lexmark International, Inc.
Address of Manufacturer	740 New Circle Rd. Lexington, Kentucky 40511

Equipment Under Test	
Trade Name(s)	RFID UHF Option
Model Number	4061-RF1
FCC ID	IYL4061-RF1
Industry Canada ID	2376A-4061RF1
Device Category	Mobile
RF Exposure Category	General Population/Uncontrolled Environment
Transmission Modes	EPC Gen 2
Frequency Range (MHz)	902.720 – 927.008
Maximum Conducted RF Output Power (dBm)	26.09
Antenna Type	Cabled from PCB to mounted antenna
Antenna Location	Internal to EUT
Antenna Gain (dBi)	-14.3

2.1 PURPOSE OF TESTING

The purpose of this testing was to evaluate the EUT for compliance to the FCC and Industry Canada Rules for a frequency hopping RFID device operating in the frequency range 902-928 MHz.

2.2 APPLIED STANDARDS

- [1] FCC Part 15 Rules and Regulations
- [2] RSS-210, Issue 7, *Low Power License-Exempt Radiocommunication Devices (All Frequency Bands)*
- [3] RSS-Gen, Issue 2, *General Requirements and Information for the Certification of Radiocommunication Equipment.*

3 SUMMARY

The purpose of this testing was to reevaluate the EUT for compliance to the FCC and Industry Canada Rules for a frequency hopping RFID device operating in the frequency range 902-928 MHz. The data included in this report demonstrates that the EUT complies with these requirements.

The following is a summary of the testing documented in this report:

FCC Rules	Description of Test	Result	Page of this Report
§15.247(a)(1)	Hopping channel separation	Compliant	15
§15.247(a)(1)(i)	Number of hopping channels	Compliant	17
§15.247(a)(1)(i)	20 dB bandwidth	Compliant	12
§15.247(a)(1)(i)	Average time of occupancy	Compliant	19
§15.247(b)(2)	Peak output power	Compliant	24
§15.247(d)	Conducted out of band emissions	Compliant	34
§15.203	Antenna	Compliant	8
§15.209	Radiated emissions	Compliant	39
§15.207	Conducted emissions	Compliant	43
§15.247(i)	RF exposure	Compliant	46

Industry Canada RSS-210 & RSS-Gen	Description of Test	Result	Page of this Report
§A8.1(2) [2]	Hopping channel separation	Compliant	15
§A8.1(3) [2]	Number of hopping channels	Compliant	17
§A8.1(3) [2]	20 dB bandwidth	Compliant	12
§A8.1(3) [2]	Average time of occupancy	Compliant	19
§A8.4(1) [2]	Peak output power	Compliant	24
§A8.5 [2]	Conducted out of band emissions	Compliant	34
§7.1.4 [3]	Antenna	Compliant	8
§7.2.3.2 [3]	Radiated emissions	Compliant	39
§7.2.2 [3]	Conducted emissions	Compliant	43
§5.5 [3]	RF exposure	Compliant	46

This report has been reviewed by:

Keith Hardin

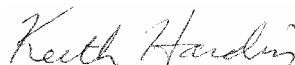

March 24, 2008

Name

Signature

Date

4 DESCRIPTION OF EUT

The Equipment Under Test (EUT) is an RFID option for a Lexmark T640, T642 and T644 laserprinter and provides an integrated RFID reader capable of reading and writing to passive tags. The option sits immediately below the laserprinter and communicates with the printer via a serial cable to a serial option card installed in the expansion port of the printer. The RFID reader is a ThingMagic Mercury 5e multi-protocol UHF RFID reader. The option only supports the EPC Gen2 tag mode.

4.1 EUT PHOTOS



Figure 1. Front view of EUT installed with laserprinter.

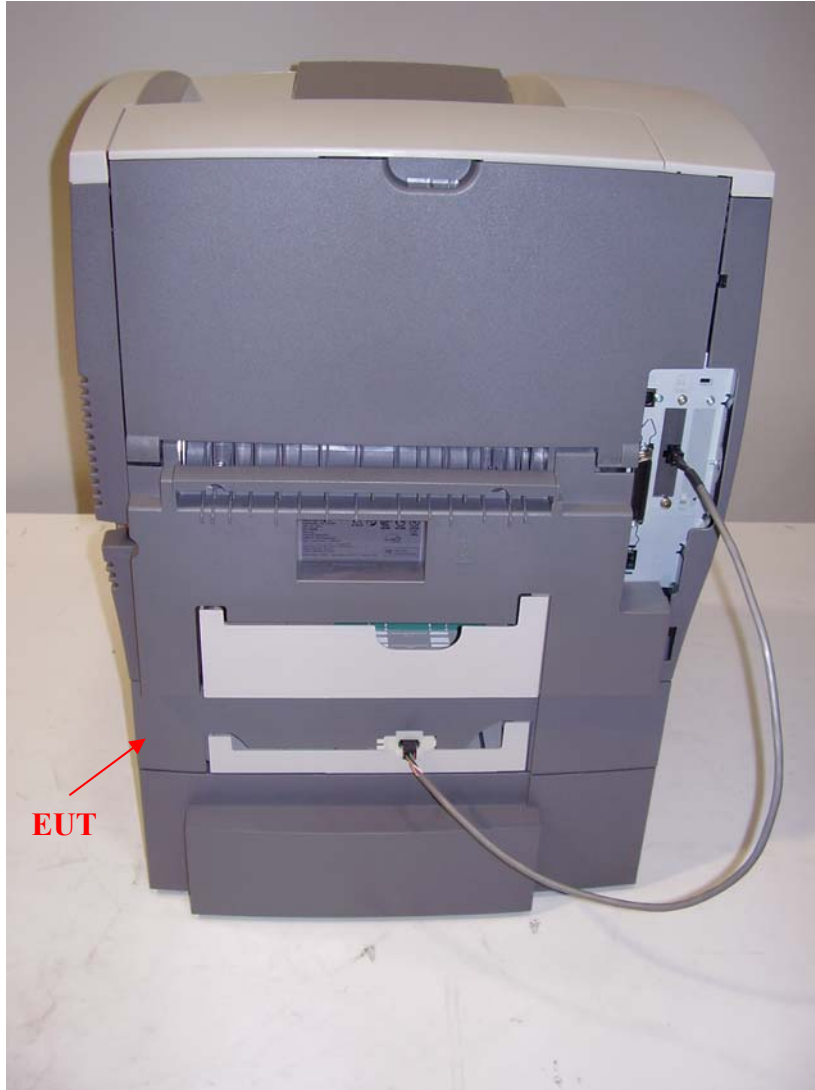

Figure 2. Rear view of EUT installed with laserprinter.

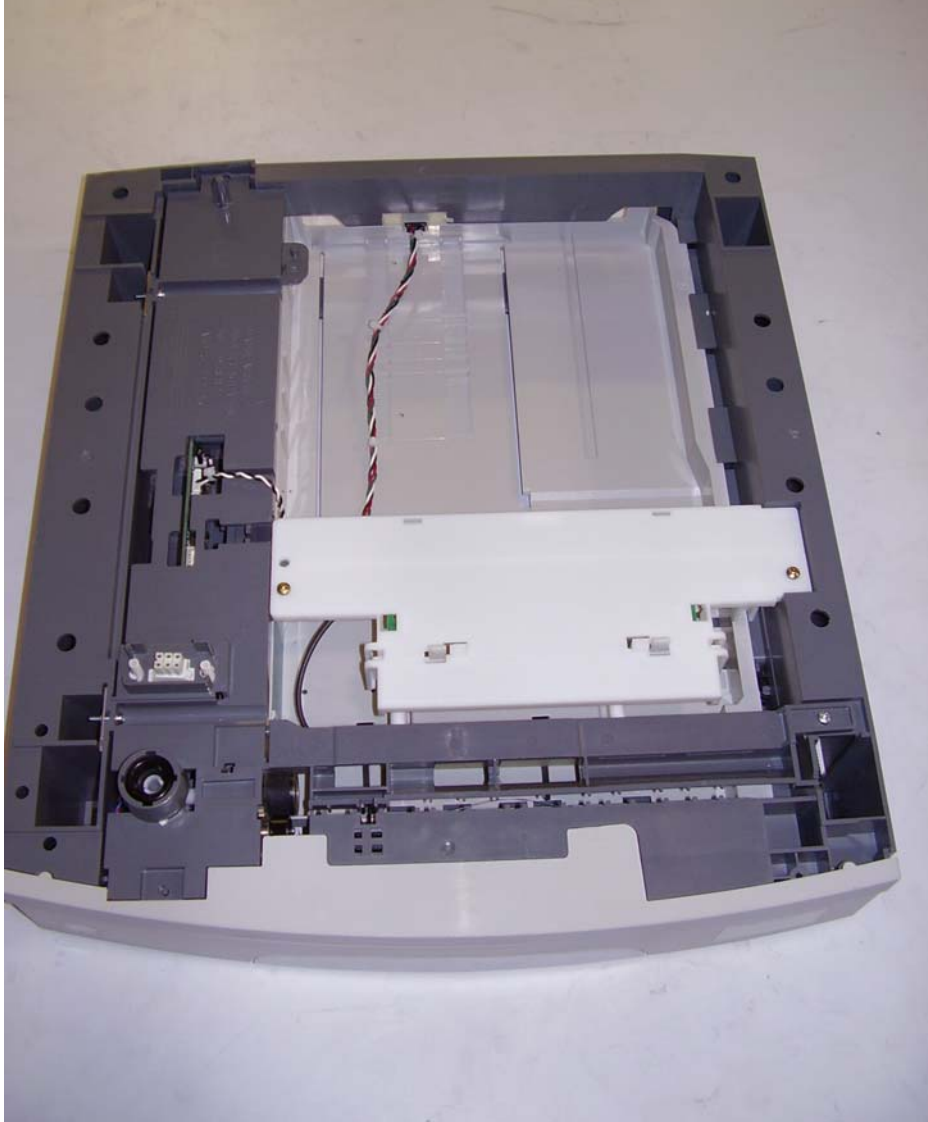

Figure 3. Top-front view of EUT.



Figure 4. Top-rear view of EUT.

4.2 EUT ANTENNA

The EUT employs a planar antenna internal to the option, as shown in Figures 5 and 6. A coaxial cable connects the antenna to the RF output port of the transmitter. A MMCX connector is used at the RF output port and a SMA connector is used at the antenna. The SMA connector is soldered to the SMA jack on the antenna PCB. The RF port of the reader is not available externally and removal of or accessing the antenna would require disassembly of a portion of the EUT, which the user would not be expected to do. The EUT meets the requirement that no antenna other than the one supplied with the EUT can be used.

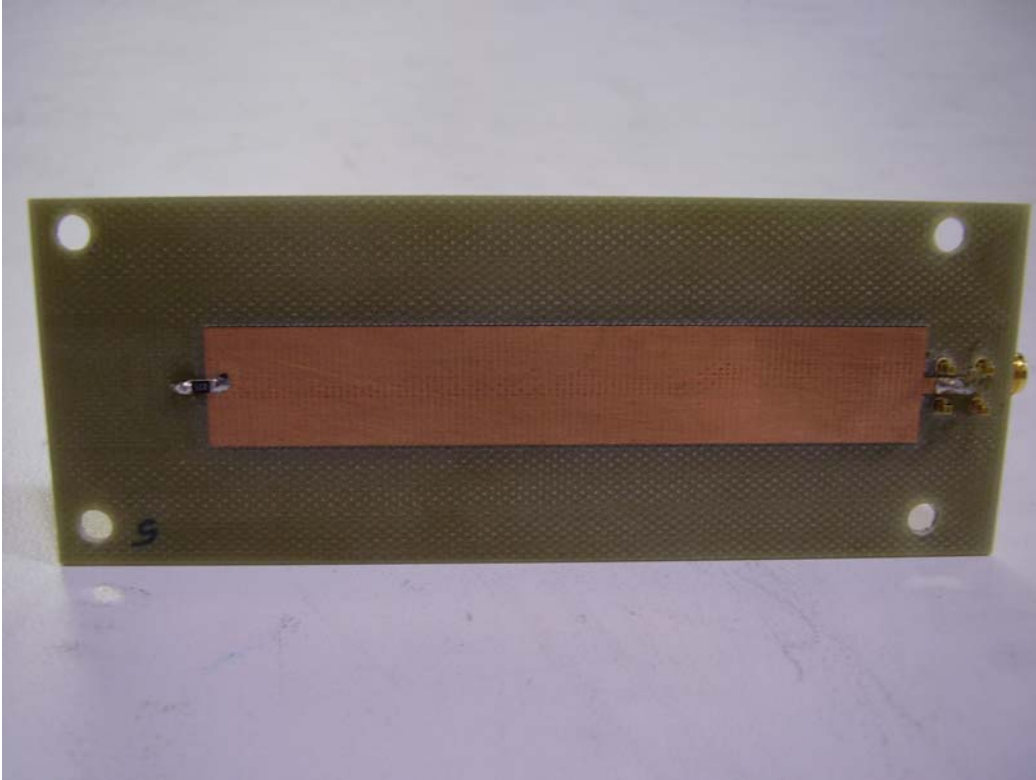
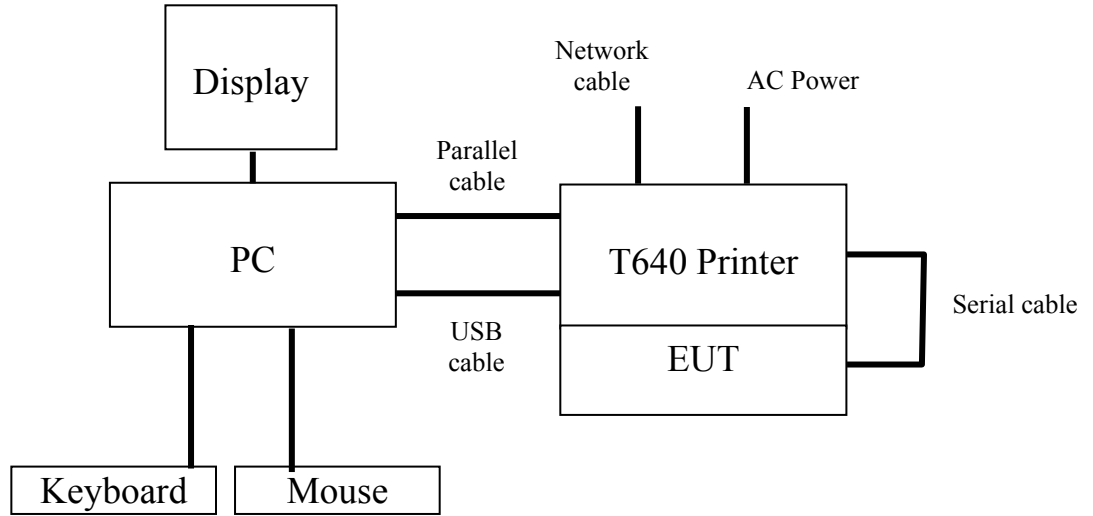

Figure 5. Front view of antenna removed from EUT.



Figure 6. Back view of antenna removed from EUT.

5 TEST CONFIGURATION



The following auxiliary equipment was used during the testing of the EUT:

Description	Manufacturer	Model
Laserprinter	Lexmark	T640
Personal Computer	Dell	Inspiron 531S
Display	Dell	1708FPb

6 CABLE INFORMATION

Cables used for testing included the following:

Cable Description	Cable Length (meters)	Ferrites	Shield Status
USB cable from PC to printer	2	No	Shielded
Parallel cable from PC to printer	3	No	Shielded
PC to LCD display	2	Yes	Shielded
Network cable to printer	> 3	No	Unshielded
Serial cable from EUT to printer	0.63	No	Shielded

7 TESTING & MEASUREMENT EQUIPMENT

Description	Manufacturer	Model Number	Serial Number	Calibration Due Date
EMI receiver	Rhode & Schwarz	ESI7	100092	4/9/09
EMI receiver	Rhode & Schwarz	ESIB7	100093	12/14/08
EMI receiver	Rhode & Schwarz	ESIB40	1112950683	10/18/09
EMI receiver	Rhode & Schwarz	ESIB40	100148	4/26/09
EMI receiver	Rhode & Schwarz	ESCI	100346	7/30/08
EMI receiver	Rhode & Schwarz	ESCI	100347	7/18/09
Spectrum analyzer	Rhode & Schwarz	FSP	100101	10/29/08
Bi-Log antenna	Chase	CBL6111C	2459	9/21/08
Bi-Log antenna	Chase	CBL6111C	2460	10/2/08
Loop antenna (9 kHz - 30 MHz)	Rhode & Schwarz	HFH 2Z2	881056/074	10/18/08
LISN	Rhode & Schwarz	ESH2-Z5	848765/017	8/2/09
LISN	Rhode & Schwarz	ESH2-Z5	890484/012	8/30/09
Horn antenna (1 - 18 GHz)	Antenna Research	DRG-1181A	1091	N/A
Horn antenna (18 - 40 GHz)	Antenna Research	DRG1840A	1047	N/A
High Pass Filter	Mini-Circuits	VHP-16	N/A	As needed

8 TEST RESULTS

8.1 20 dB BANDWIDTH

Criteria for 20 dB Bandwidth: For frequency hopping systems operating in the 902-928 MHz band, the maximum allowed 20 dB bandwidth of the hopping channel is 500 kHz.

Test Procedure for 20 dB Bandwidth: The antenna port of the EUT was connected directly to the input of the spectrum analyzer via a short coaxial cable. The insertion loss of the interconnecting coaxial cable was stored as transducer factors in the spectrum analyzer and automatically accounted for in the readings. The resolution and video bandwidths of the analyzer were set to 10 kHz and 30 kHz, respectively. The frequency span was set so that the entire channel of operation could be displayed on the spectrum analyzer. The max hold function was used to capture the maximum levels over this frequency range. Markers and display lines were then used to determine the two frequencies on the upper and lower edge of the channel where the amplitude was 20 dB below the highest amplitude within the channel. The difference in the frequencies of the upper and lower markers represents the 20 dB bandwidth of the channel.

With the EUT operating in the EPC Gen2 mode, the bandwidth of the EUT was measured on the highest, lowest and middle channels. The hopping function was disabled for this testing.

Results for 20 dB Bandwidth: See Table 1 and Figures 7 - 9 for results. The maximum 20 dB bandwidth measured was 76.0 kHz. The EUT met the requirements for 20 dB bandwidth.

Channel	20 dB Bandwidth (kHz)	20 dB Bandwidth Limit (kHz)
1	76.0	500.0
25	72.0	500.0
50	70.5	500.0

Table 1. Measured data for 20 dB bandwidths.

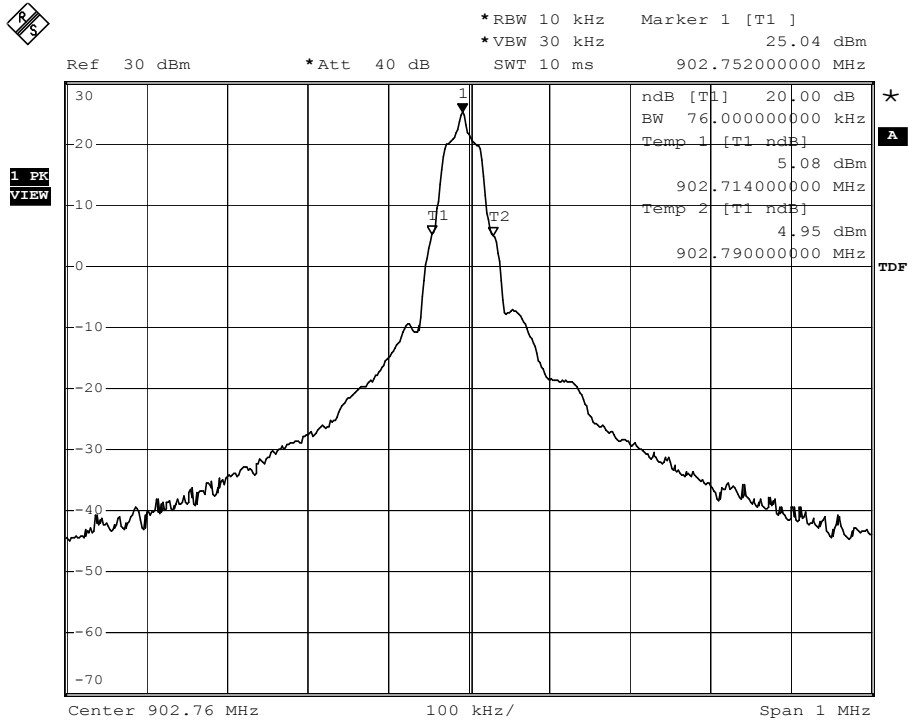

Figure 7. 20 dB Bandwidth, EPC Gen2, Channel 1.

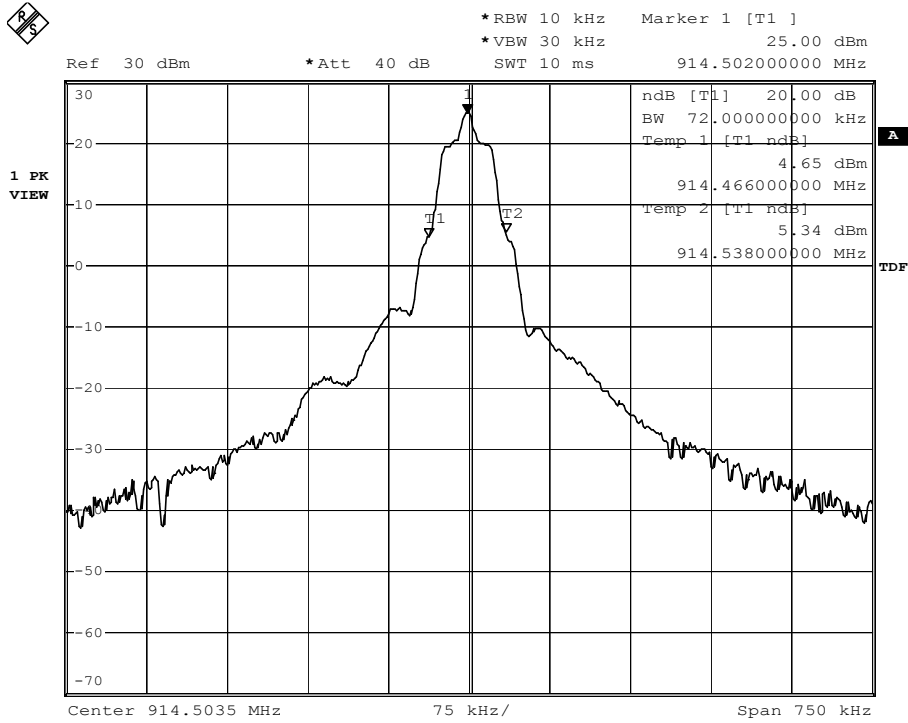

Figure 8. 20 dB Bandwidth, EPC Gen2, Channel 25.

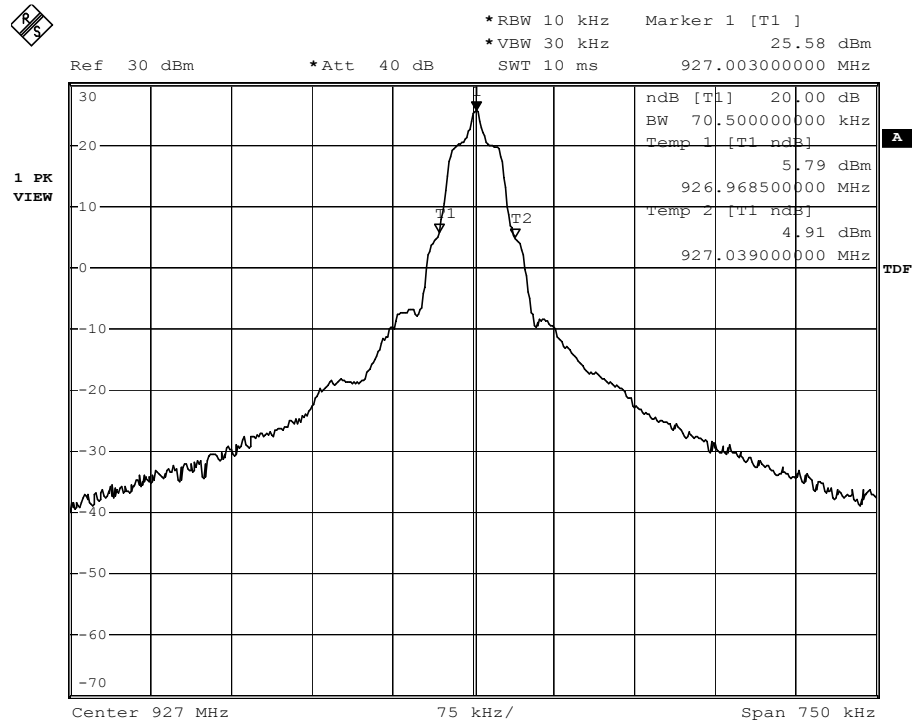

Figure 9. 20 dB Bandwidth, EPC Gen2, Channel 50.

8.2 HOPPING CHANNEL SEPARATION

Criteria for Hopping Channel Separation: Frequency hopping systems operating in the 902-928 MHz band shall have hopping channel carrier frequencies separated by a minimum of 25 kHz or the 20 dB bandwidth of the hopping channel, whichever is greater.

Test Procedure for Hopping Channel Separation: The antenna port of the EUT was connected directly to the input of the spectrum analyzer via a short coaxial cable. The insertion loss of the interconnecting coaxial cable was stored as transducer factors in the spectrum analyzer and automatically accounted for in the readings. The resolution and video bandwidths of the analyzer were set to 100 kHz and 300 kHz, respectively. The center frequency was set to 915 MHz, the center of the hopping frequencies. The frequency span was set so that at least 4 channels could be observed. The max hold function was used to capture the maximum levels over this frequency range. Markers were then used to determine the difference in the frequencies of two channels.

The EUT was operated in the EPC Gen2 mode with the hopping function enabled.

Results for Hopping Channel Separation: See Figure 10 for results. The hopping channel separation is 504.0 kHz. Since the maximum 20 dB bandwidth was 76.0 kHz, the EUT met the requirement for hopping channel separation.

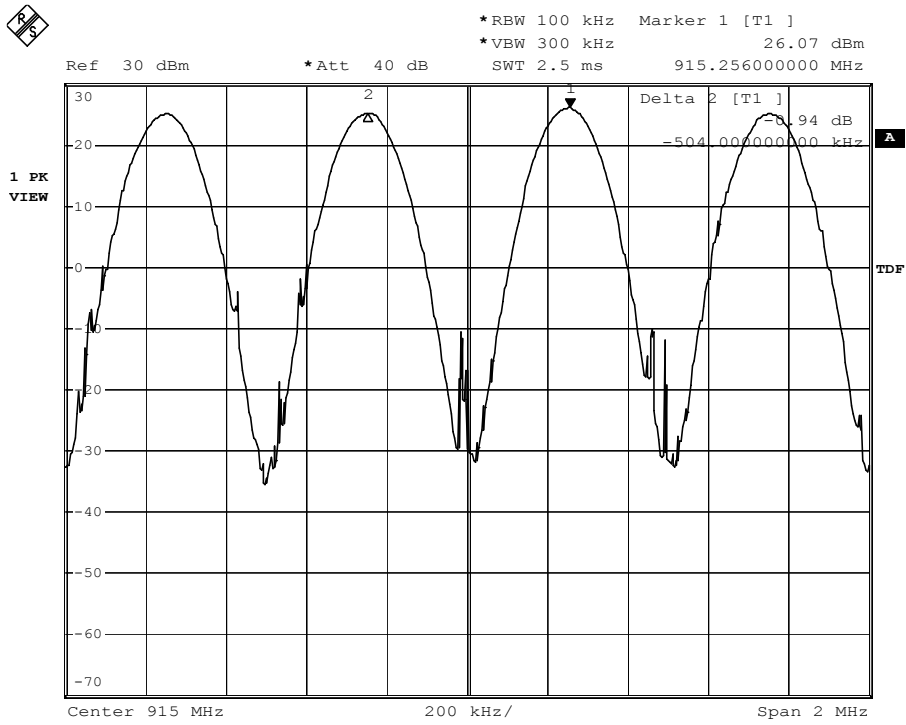

Figure 10. Hopping channel separation.

8.3 NUMBER OF HOPPING CHANNEL FREQUENCIES

Criteria for Number of Hopping Channel Frequencies: For frequency hopping systems operating in the 902-928 MHz band, if the 20 dB bandwidth of the hopping channel is less than 250 kHz, the system shall use at least 50 hopping frequencies. If the 20 dB bandwidth of the hopping channel is 250 kHz or greater, the system shall use at least 25 hopping frequencies.

Test Procedure for Number of Hopping Channel Frequencies: The antenna port of the EUT was connected directly to the input of the spectrum analyzer via a short coaxial cable. The insertion loss of the interconnecting coaxial cable was stored as transducer factors in the spectrum analyzer and automatically accounted for in the readings. The resolution and video bandwidths of the analyzer were set to 100 kHz and 300 kHz, respectively. The frequency span was set so that the entire frequency range of operation could be displayed on the spectrum analyzer. The max hold function was used to capture the maximum levels over this frequency range.

The EUT was operated in the EPC Gen2 mode with the hopping function enabled.

Results for Number of Hopping Channel Frequencies: See Figure 11 for results. The number of hopping channels used by the EUT is 50. Since the range of the 20 dB bandwidth was 70.5 kHz – 76.0 kHz, the EUT met the requirements of using at least 50 hopping channel frequencies.

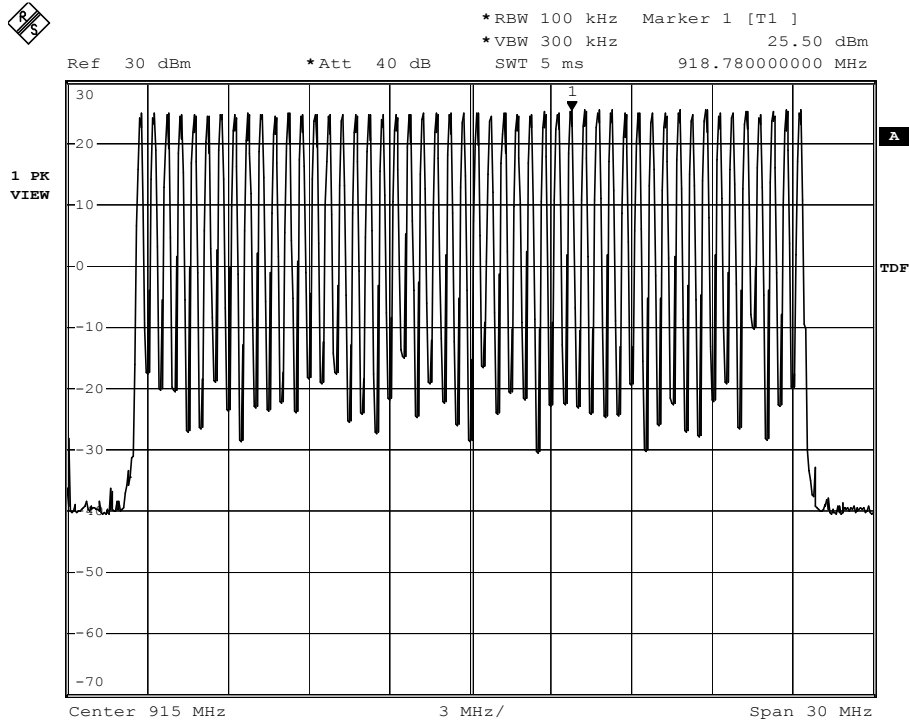

Figure 11. Number of hopping channels.

8.4 AVERAGE TIME OF OCCUPANCY

Criteria for Average Time of Occupancy: For frequency hopping systems operating in the 902-928 MHz band, if the 20 dB bandwidth of the hopping channel is less than 250 kHz, the average time of occupancy on any frequency shall not be greater than 400 milliseconds within a 20 second period. If the 20 dB bandwidth of the hopping channel is 250 kHz or greater, the average time of occupancy on any frequency shall not be greater than 400 milliseconds within a 10 second period.

Test Procedure for Average Time of Occupancy: The antenna port of the EUT was connected directly to the input of the spectrum analyzer via a short coaxial cable. The insertion loss of the interconnecting coaxial cable was stored as transducer factors in the spectrum analyzer and automatically accounted for in the readings. The resolution and video bandwidths of the analyzer were set to 100 kHz and 300 kHz, respectively. The frequency span was set so that the entire channel of operation could be displayed on the spectrum analyzer. The max hold function was used to capture the maximum levels over this frequency range. The frequency that corresponded to the highest amplitude in the channel was then set to be the center frequency.

The span was then set to 0 MHz and the sweep time was set to 10 seconds. The number of times N the channel was occupied in a 10 second interval was then measured.

The sweep time was then set to 50 ms and the total time (t_{ON}) the channel was active within an occurrence was measured. The total time a channel was occupied within a period of 10 seconds can be calculated using the following equation:

$$t_{occupied} = N t_{ON}$$

For the total time a channel is occupied in a 20 second period, the above result is multiplied by two. The EUT was operated in the EPC Gen2 mode with the hopping function enabled. The measurements were performed while centered on the lowest, highest and middle channels.

Results for Average Time of Occupancy: See Table 2 for results. Measured number of occurrences and dwell times are found in Figures 12 - 17. From Table 1, the maximum 20 dB bandwidth was 76.0 kHz so the maximum occupancy time shall not be greater than 400 milliseconds in a 20 second period. The maximum occupancy time in a 20 second interval was 220 milliseconds. The EUT met the requirements for average time of occupancy.

Channel	Number Occurrences in 10 sec Interval	TON (ms)	Occupancy Time in 20 secs (ms)
1	11	9.9	217.8
25	11	10	220.0
50	11	10	220.0

Table 2. Measured data for occupancy times.

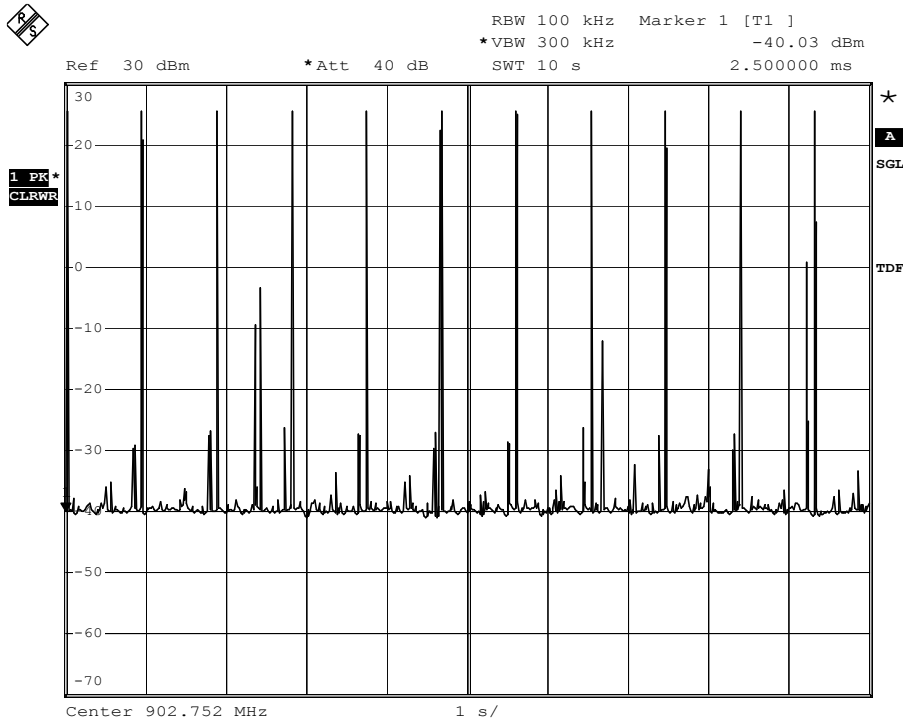

Figure 12. Number of ON events in a 10 second sweep; Channel 1.

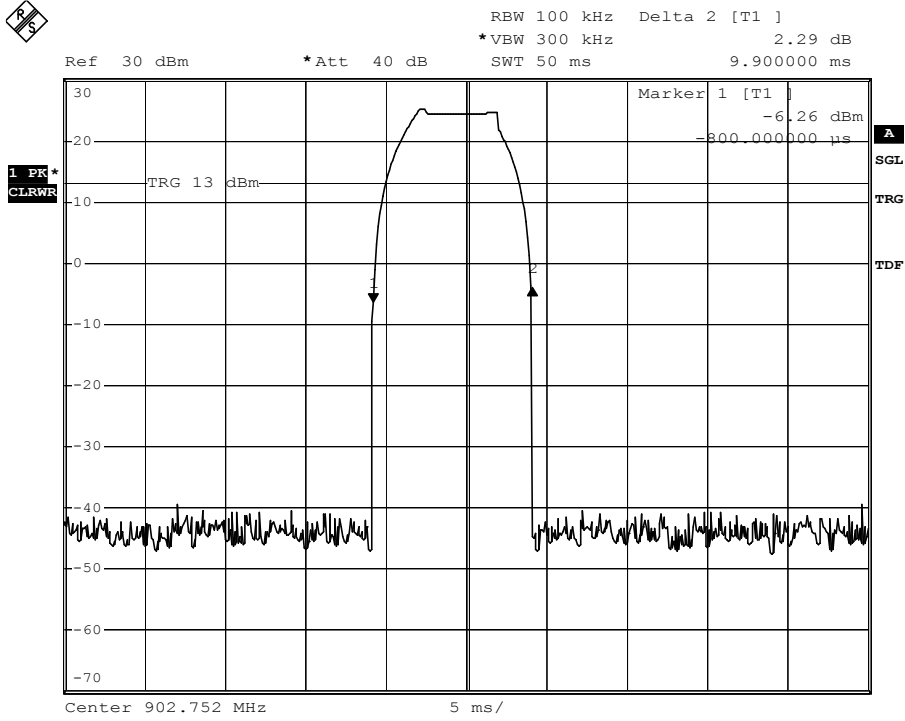

Figure 13. ON time; Channel 1.

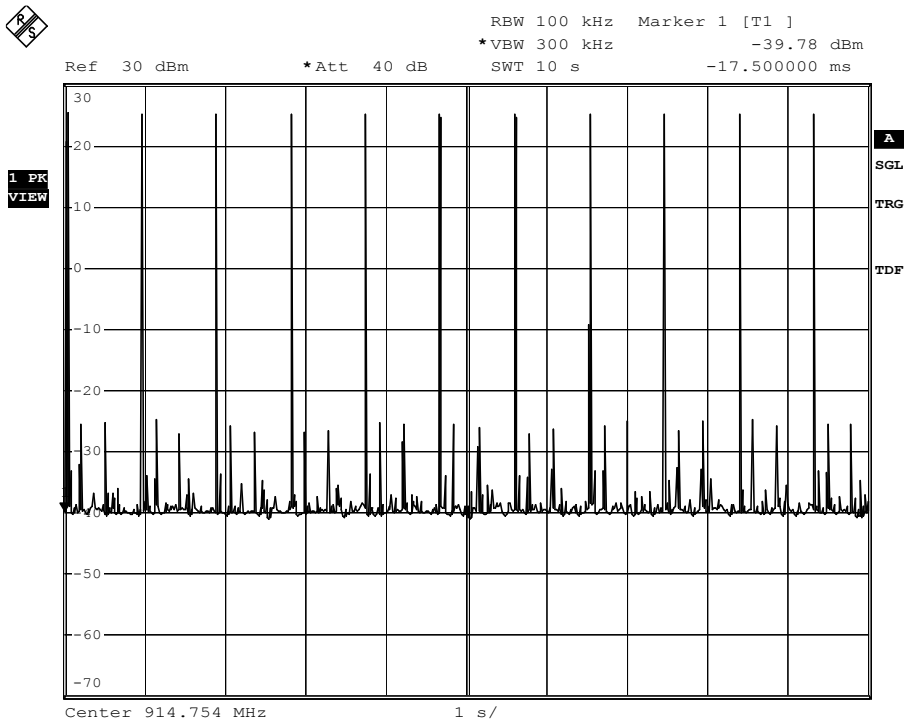

Figure 14. Number of ON events in a 10 second sweep; Channel 25.

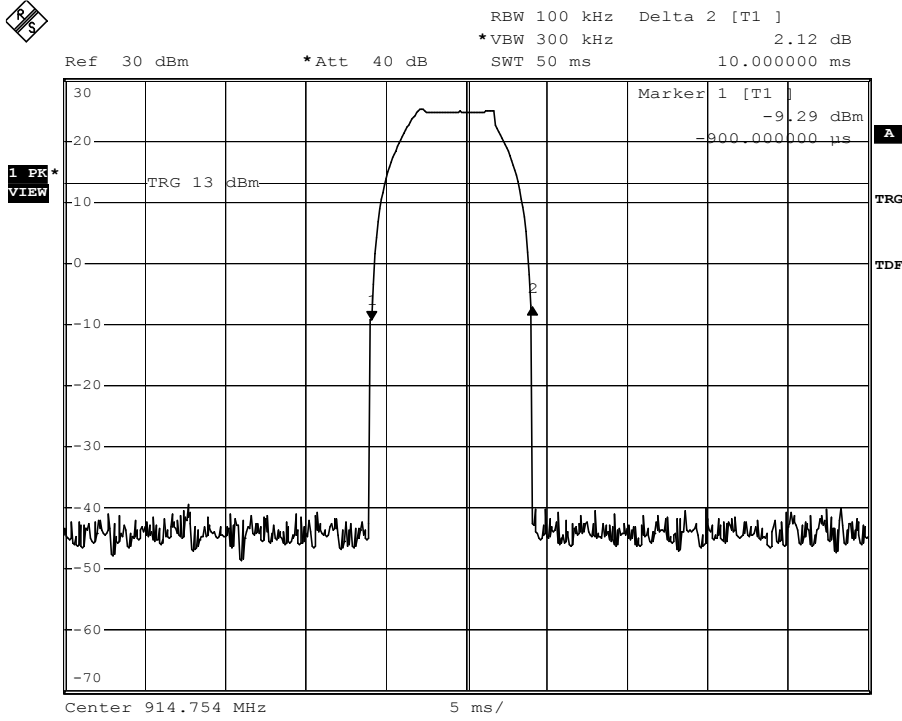

Figure 15. ON time; Channel 25.

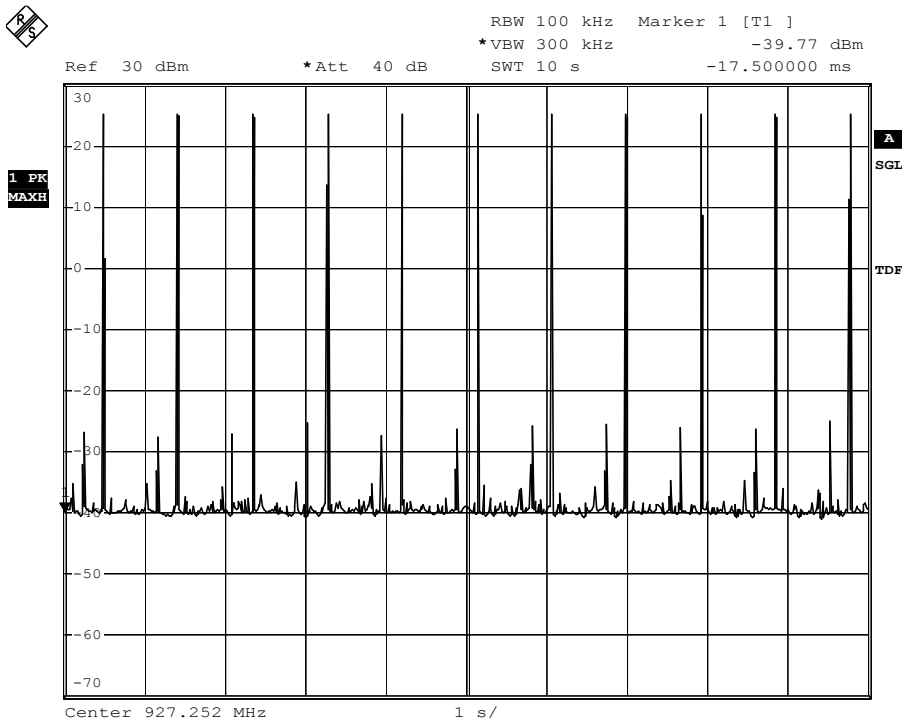

Figure 16. Number of ON events in a 10 second sweep; Channel 50.

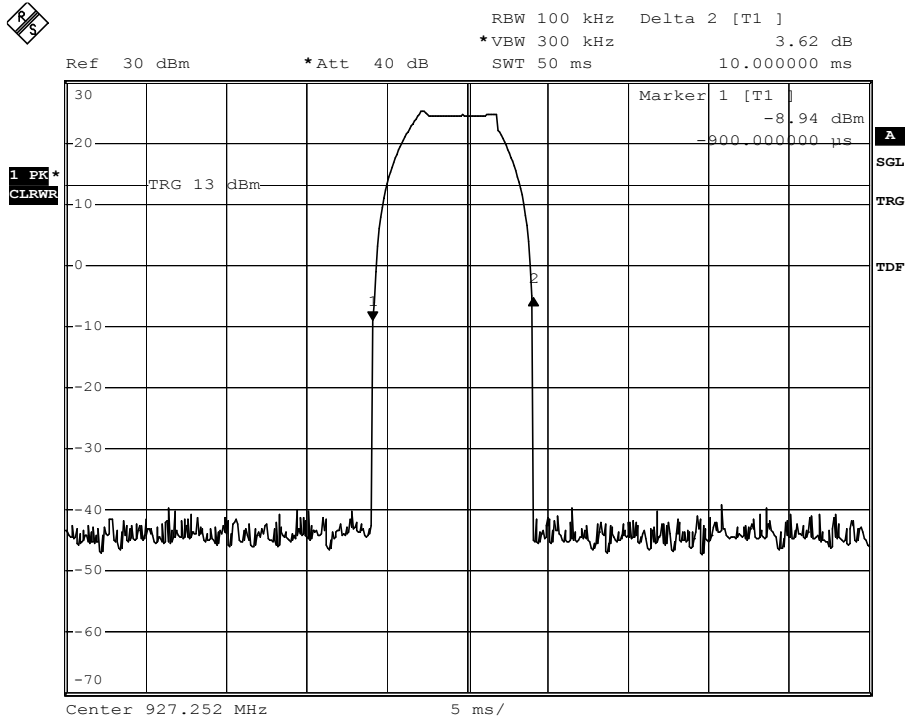

Figure 17. ON time; Channel 50.

8.5 CONDUCTED POWER

Criteria for Conducted Power: For systems using frequency hopping techniques in the 902 - 928 MHz band and employing at least 50 hopping channels, the maximum peak output power is 1 Watt (30 dBm). The variation of the input power shall be also be measured with the supply voltage varied between 85% and 115% of the nominal rated supply voltage.

Test Procedure for Conducted Power: The antenna port of the EUT was connected directly to the input of a spectrum analyzer via a short coaxial cable. The insertion loss of the interconnecting coaxial cable was stored as transducer factors in the spectrum analyzer and automatically accounted for in the readings. The resolution and video bandwidths of the analyzer were set to 1 MHz and 3 MHz, respectively. The frequency span was set to 2 MHz. The peak detector of the spectrum analyzer was used and the max hold function was used to capture the maximum levels over this frequency range. The peak search function was used to report the highest power level.

Power measurements were performed with the AC supply voltage to the EUT set to 102V/60Hz (85% nominal), 120V/60Hz (nominal) and 138V/60Hz (115% nominal).

The EUT was operated in the EPC Gen2 mode with the hopping function disabled.

Results for Conducted Power: See Figures 18 - 35 for results. Since the output power level of the EUT can be set via software control, measurements were made at the highest power setting and the lowest. The maximum conducted power for the lowest, highest and middle channels and various supply voltages was 26.09 dBm. The EUT met the requirement for a maximum output power of 30 dBm.

The results in Figures 18 - 35 also indicate the minimum and maximum frequency range of operation for the EUT. As seen in these results, the minimum center frequency of Channel 1 is 902.720 MHz and the maximum center frequency of Channel 50 is 927.008 MHz.

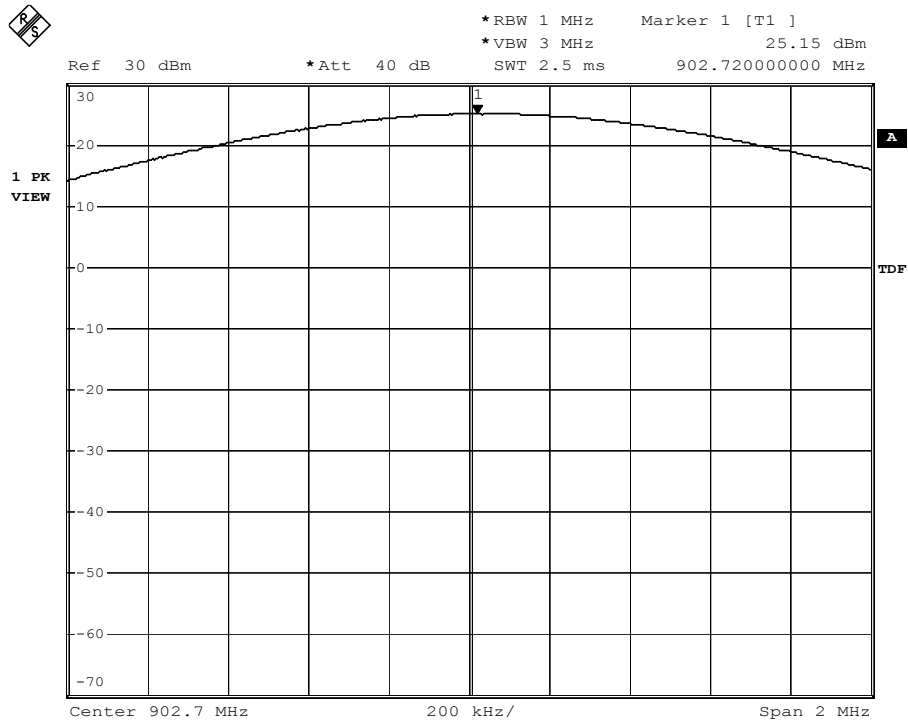

Figure 18. Conducted output power; Channel 1, nominal voltage.

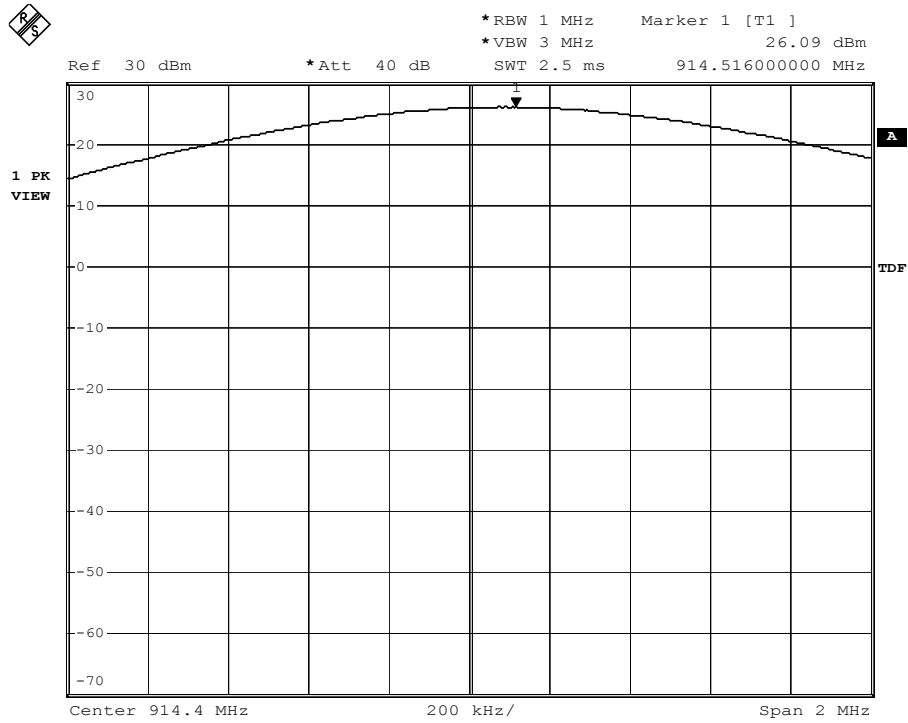

Figure 19. Conducted output power; Channel 25, nominal voltage.

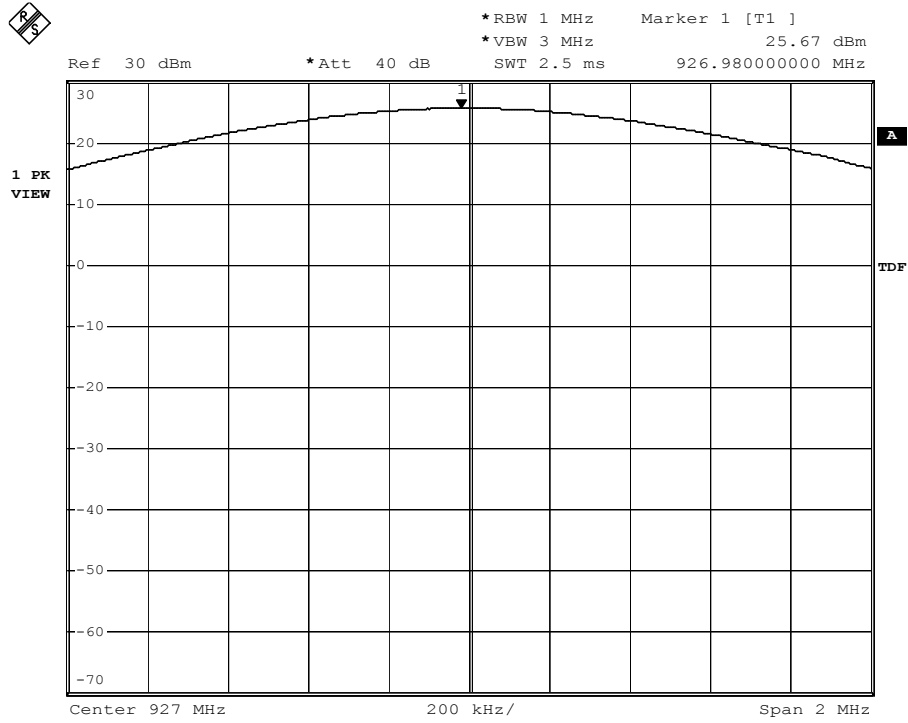

Figure 20. Conducted output power; Channel 50, nominal voltage.

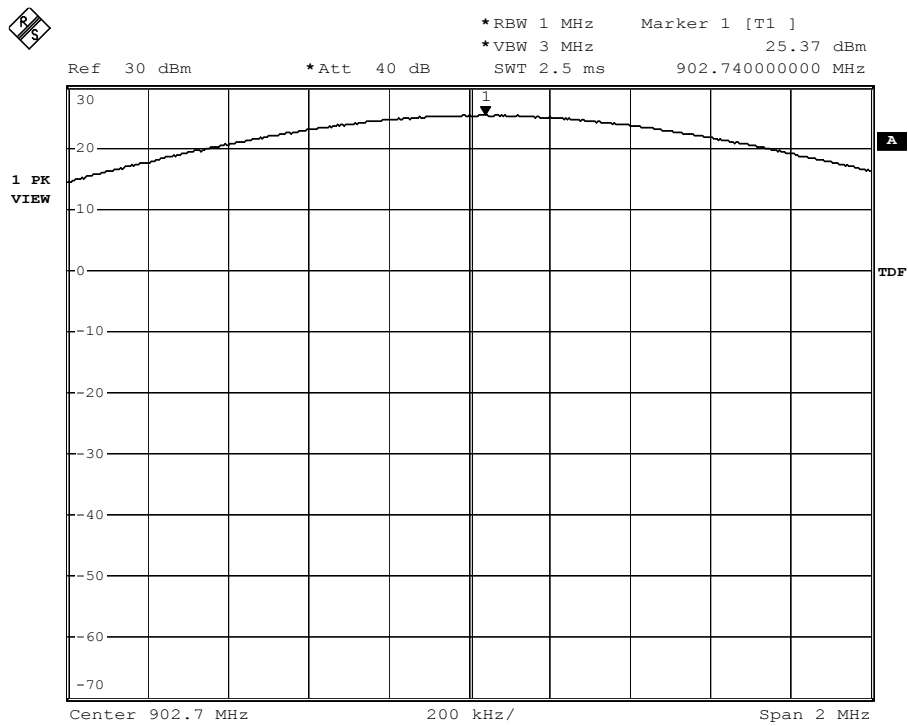

Figure 21. Conducted output power; Channel 1, 85% nominal voltage.

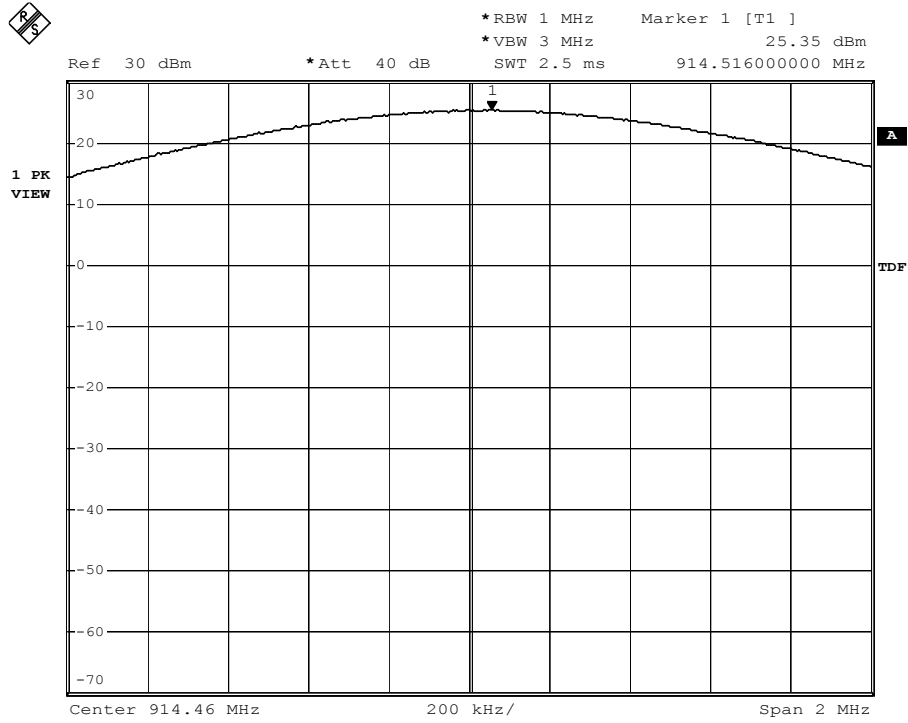

Figure 22. Conducted output power; Channel 25, 85% nominal voltage.

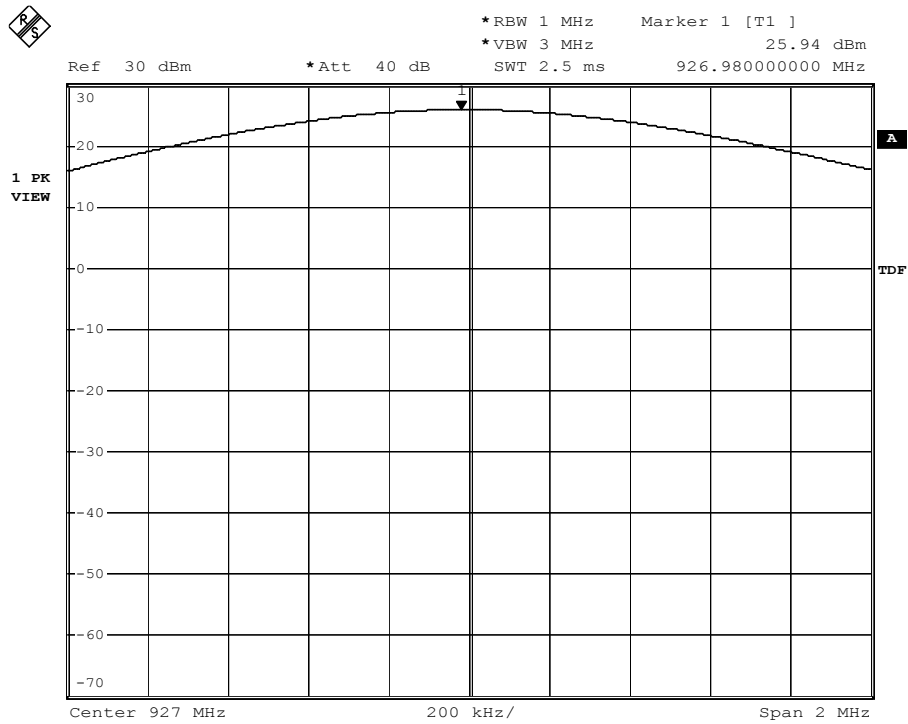

Figure 23. Conducted output power; Channel 50, 85% nominal voltage.

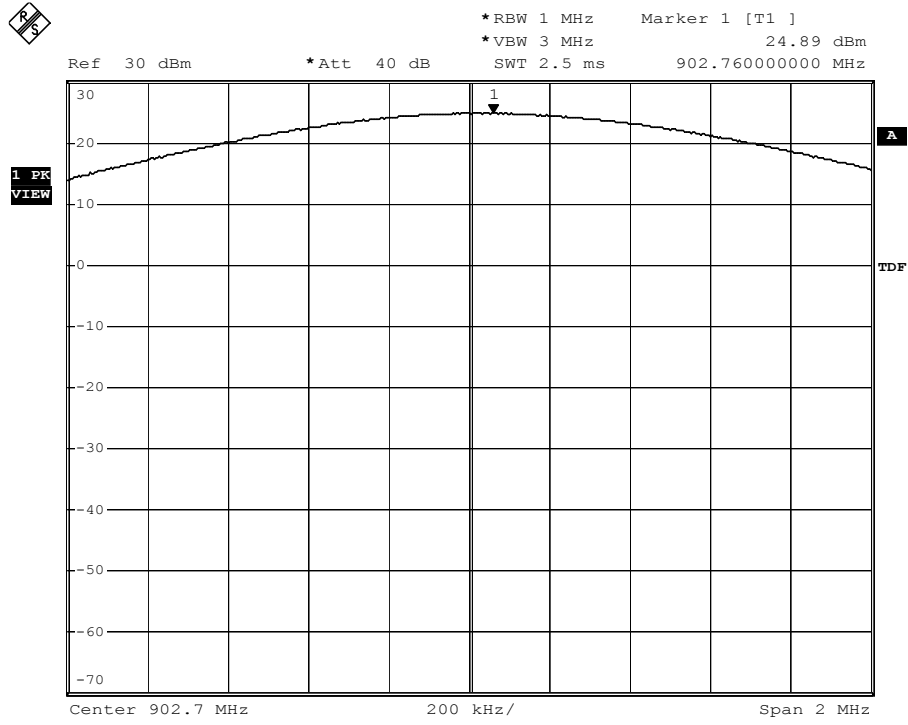

Figure 24. Conducted output power; Channel 1, 115% nominal voltage.

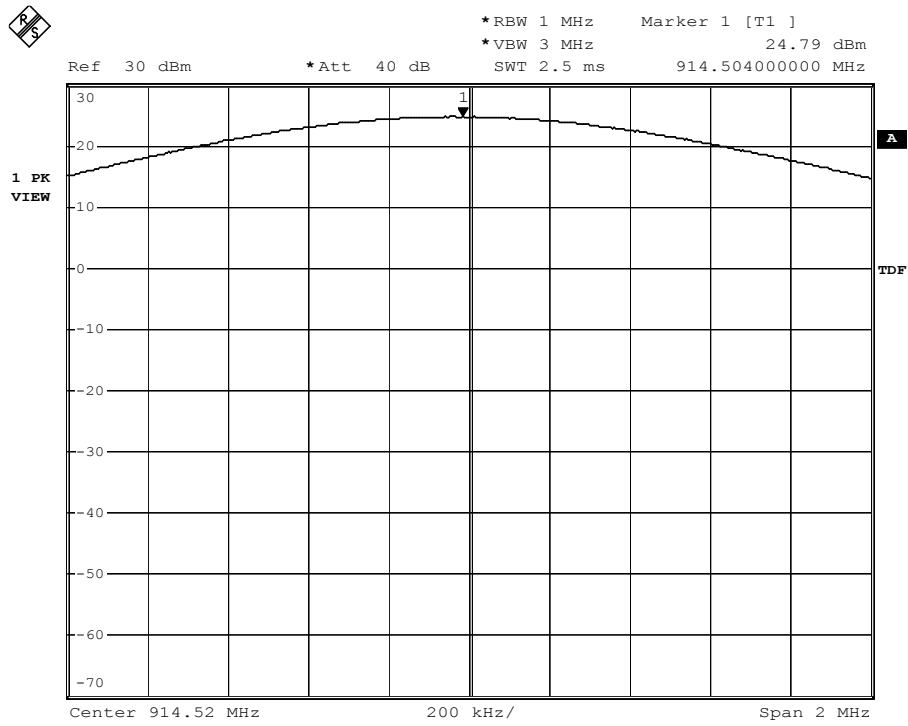

Figure 25. Conducted output power; Channel 25, 115% nominal voltage.

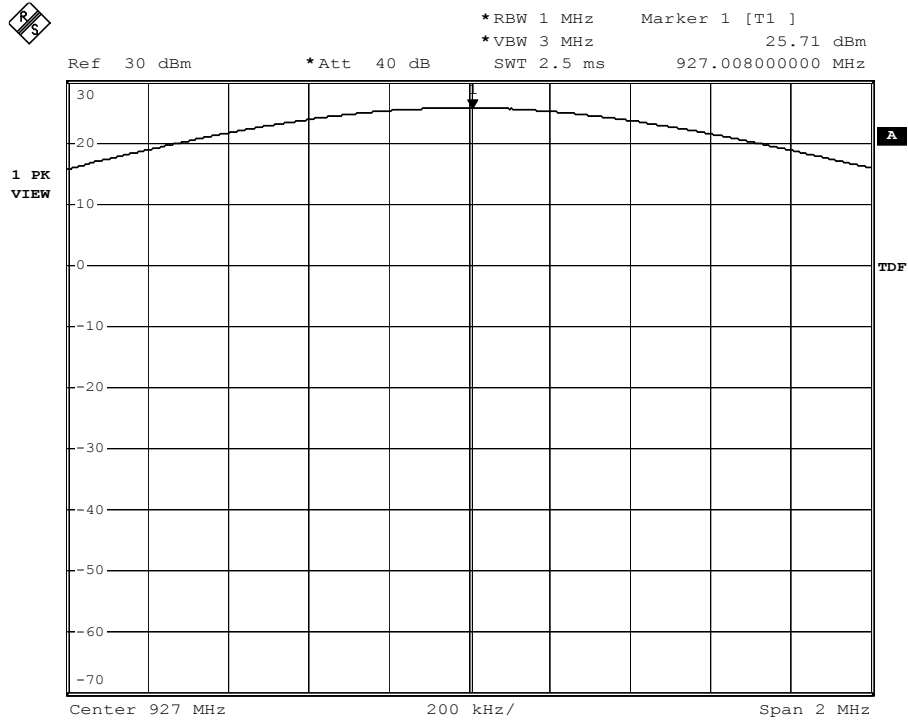

Figure 26. Conducted output power ;Channel 50, 115% nominal voltage.

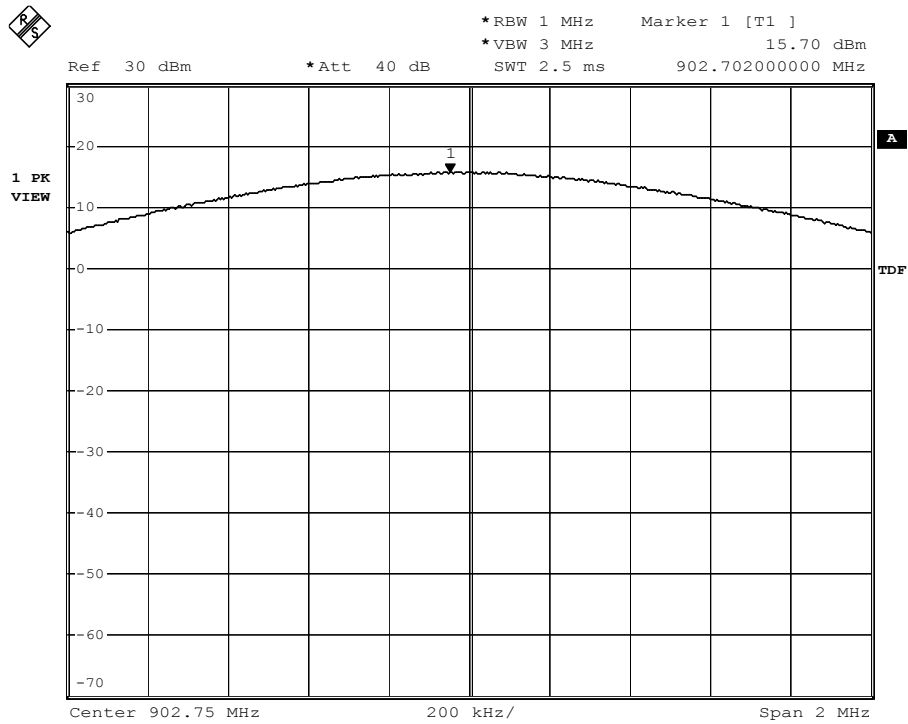

Figure 27. Conducted output power (low power setting); Channel 1, nominal voltage.

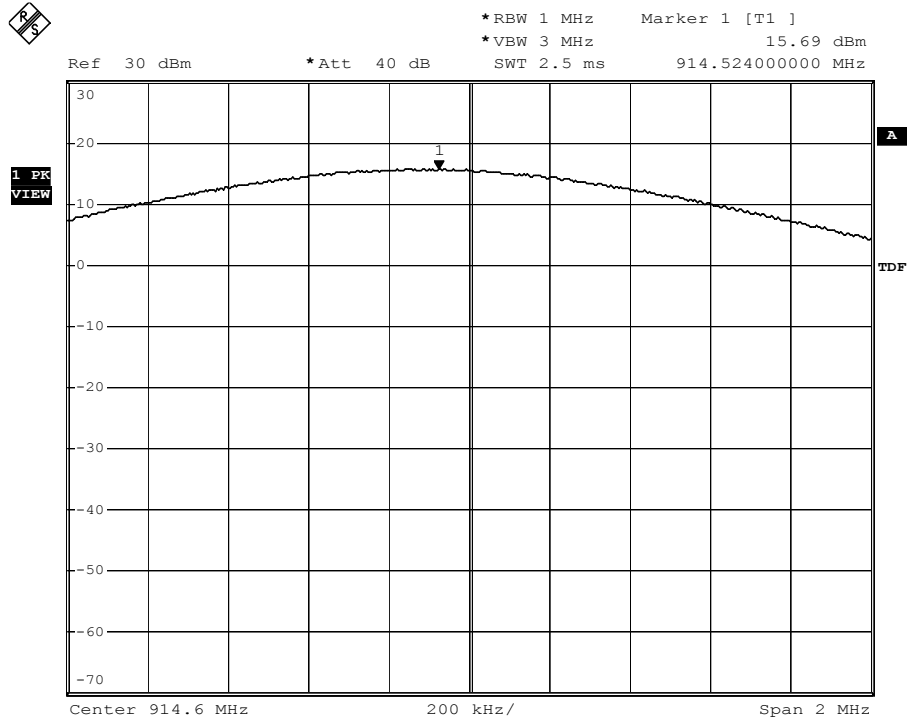

Figure 28. Conducted output power (low power setting); Channel 25, nominal voltage.

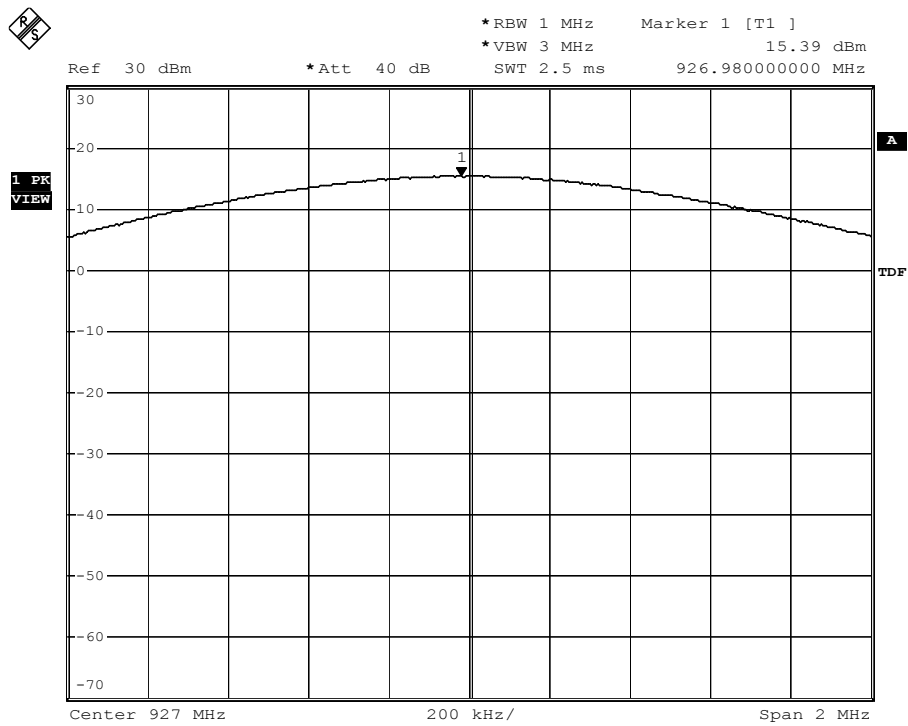

Figure 29. Conducted output power (low power setting); Channel 50, nominal voltage.

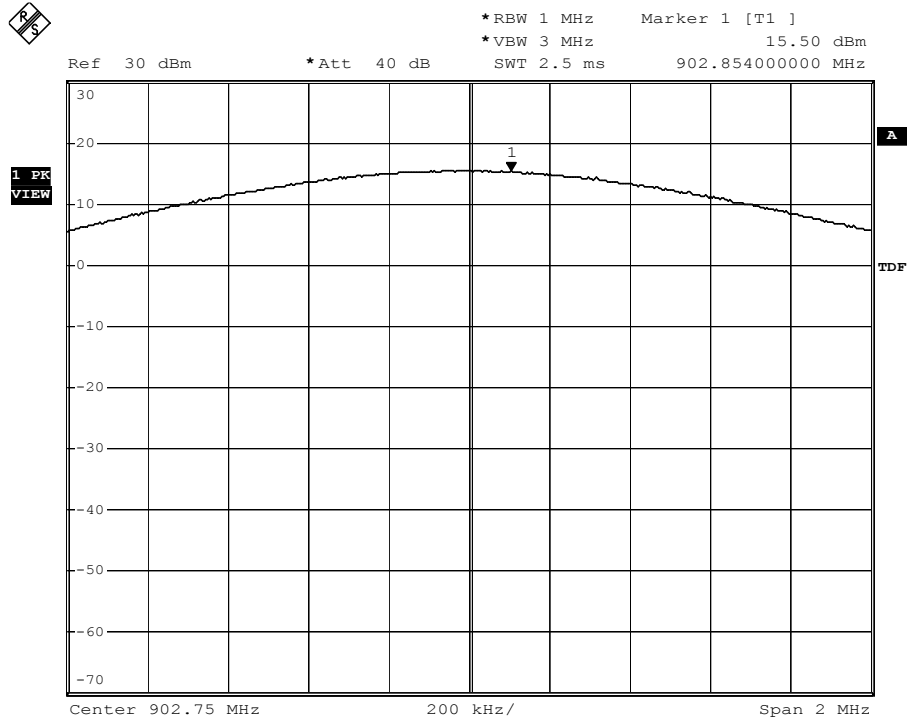

Figure 30. Conducted output power (low power setting); Channel 1, 85% nominal voltage.

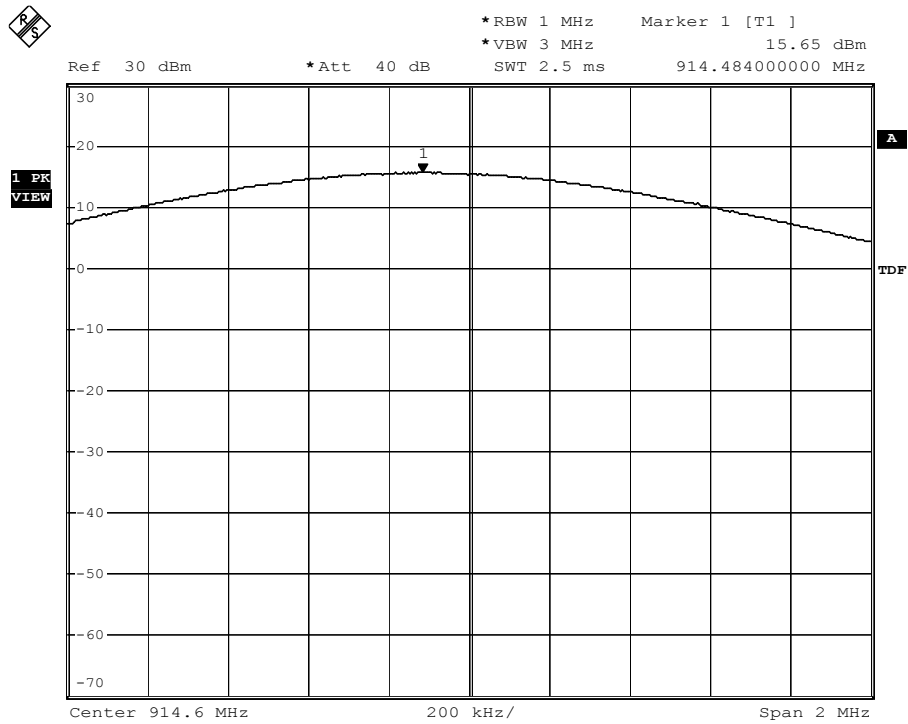

Figure 31. Conducted output power (low power setting); Channel 25, 85% nominal voltage.

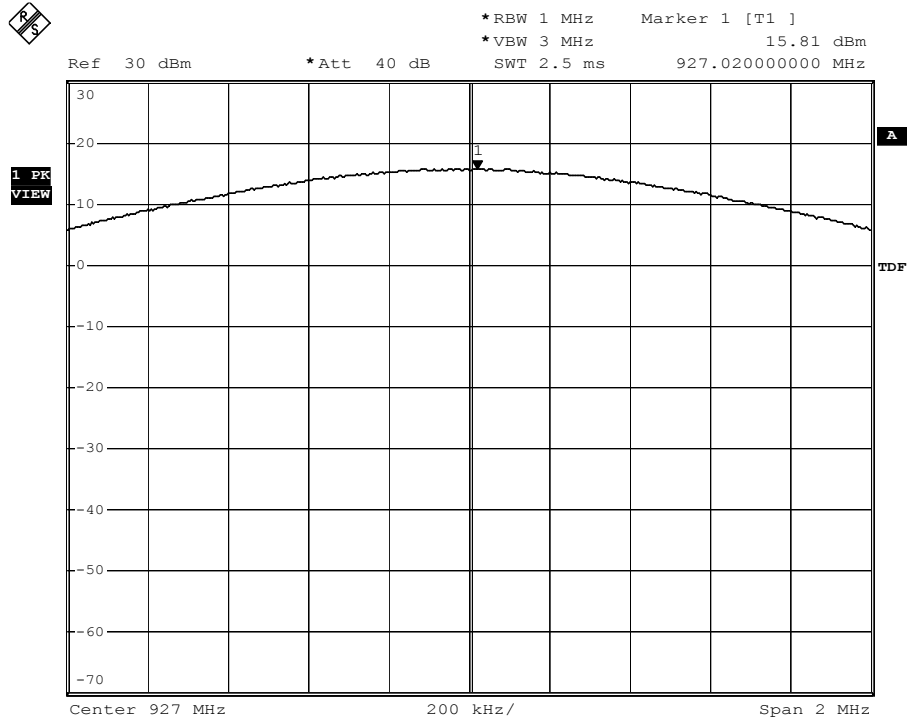

Figure 32. Conducted output power (low power setting); Channel 50, 85% nominal voltage.

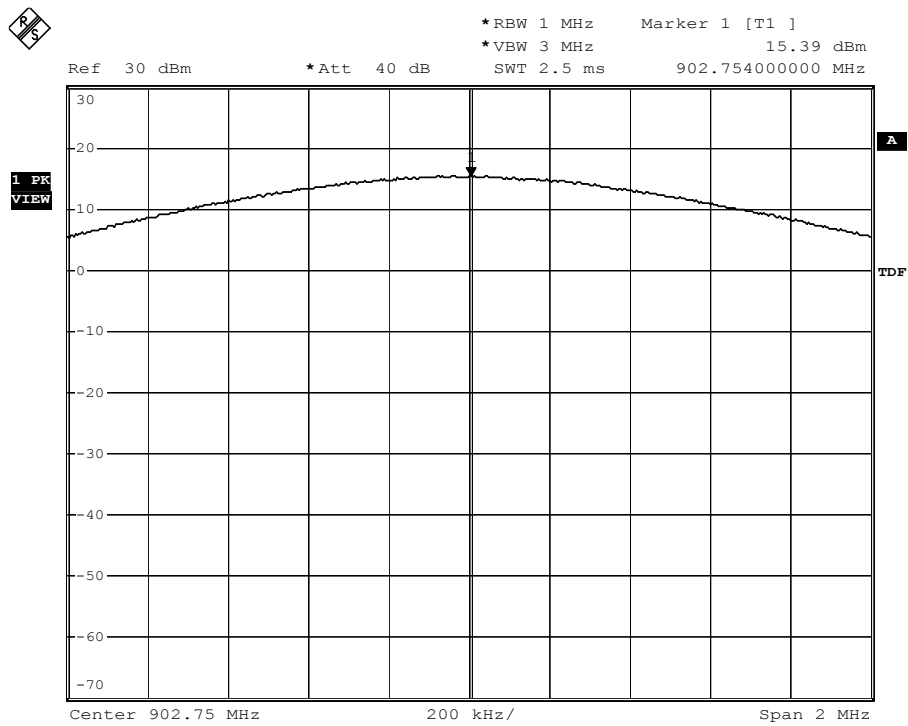

Figure 33. Conducted output power (low power setting); Channel 1, 115% nominal voltage.

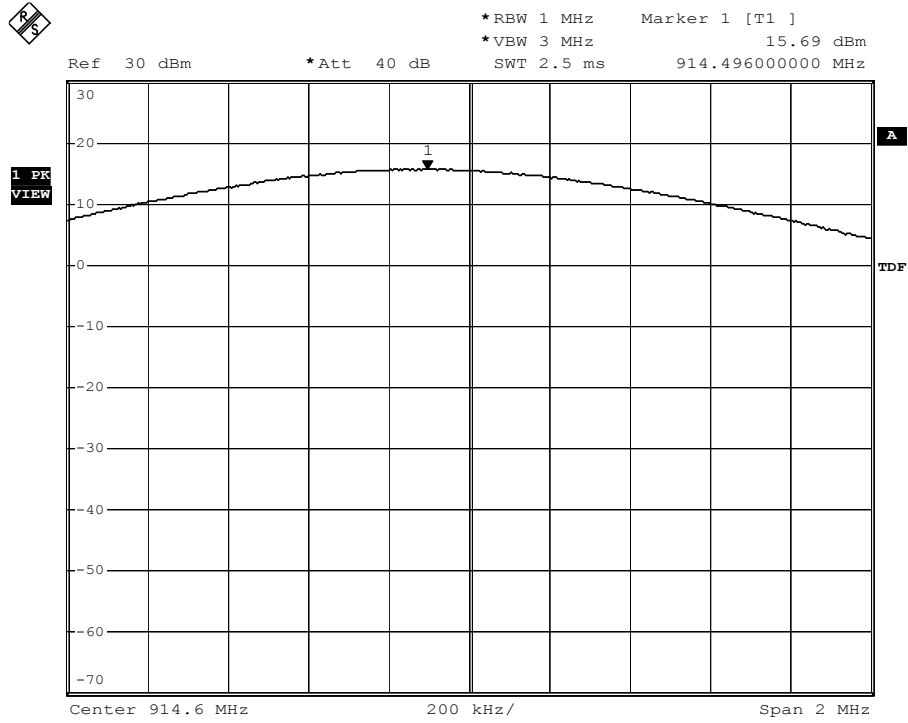

Figure 34. Conducted output power (low power setting); Channel 25, 115% nominal voltage.

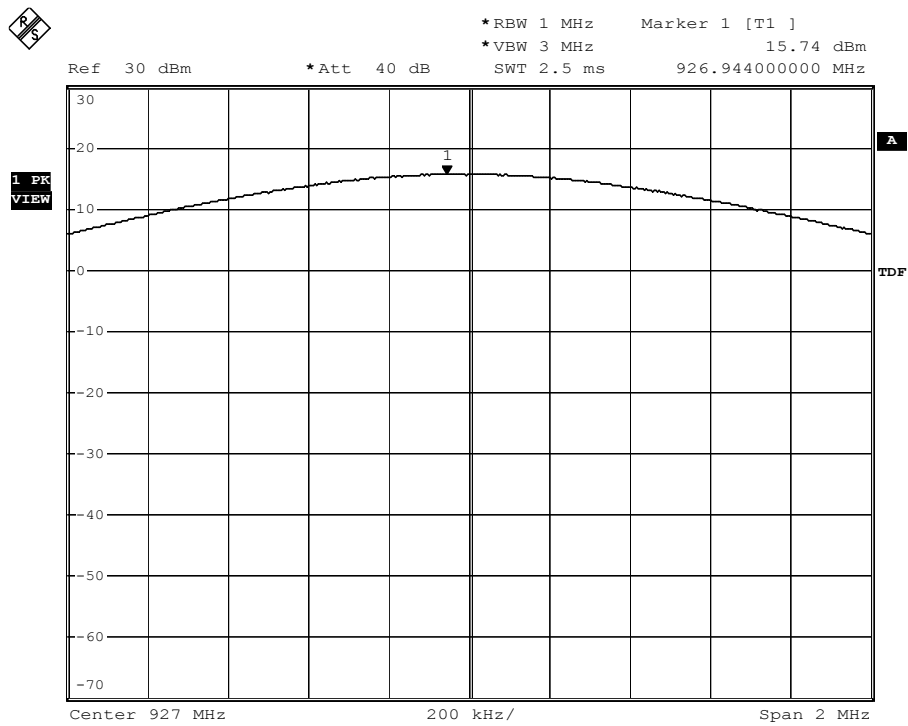

Figure 35. Conducted output power (low power setting); Channel 50, 115% nominal voltage.

8.6 OUT OF BAND EMISSIONS AT ANTENNA TERMINALS

Criteria for Out of Band Emissions at Antenna Terminals: In any 100 kHz bandwidth outside the frequency band in which the spread spectrum or digitally modulated EUT is operating, the radio frequency power that is produced by the EUT shall be at least 20 dB below that within the 100 kHz bandwidth within the band that contains the highest level of the desired power. This measurement shall be based upon either an RF conducted or a radiated measurement provided the transmitter demonstrates compliance with the peak conducted power limits. If the transmitter complies with the conducted power limits based upon the use of RMS averaging over a time interval, the attenuation required shall be 30 dB instead of 20 dB.

Test Procedure for Out of Band Emissions at Antenna Terminals: The antenna port of the EUT was connected directly to the input of the spectrum analyzer. The insertion loss of the interconnecting coaxial cable was stored as transducer factors in the spectrum analyzer and automatically accounted for in the readings. The resolution and video bandwidths of the analyzer were set to 100 kHz and 300 kHz, respectively.

In order to establish the power level in the 100 kHz bandwidth within the band that contains the desired power, the spectrum analyzer was set to sweep from 900 MHz to 930 MHz. The hopping function was enabled and the levels recorded.

The frequency span was then set to sweep from 10 MHz to 10 GHz, excluding the 900 MHz to 930 MHz band. The max hold function was used to capture the maximum levels over this frequency range. Markers and display lines were then used to determine the difference in amplitude of the fundamental emission and the highest emission other than the fundamental.

In order to confirm that the edges of the transmitting bands were compliant, further measurements were made in a frequency range immediately below the lowest channel of operation and in a frequency range immediately above the highest channel of operation. In these cases, measurements were performed in the EPC Gen2 mode and with both the hopping function enabled and disabled.

Results for Out of Band Emissions at Antenna Terminals: Figure 36 contains the results of the in-band power with the hopping function enabled. The highest power level within the desired band was 25.0 dBm. Figures 37 - 39 contain the power levels over the frequency range of 10 MHz - 10 GHz when the hopping function was enabled. This data indicates that all out of band emissions in the frequency range 10 MHz - 10 GHz were at least 20 dB below the in-band signal.

Figures 40 - 43 contain measurements for band-edge compliance in all modes with the hopping function enabled and disabled. This data indicates that all out of band emissions immediately adjacent to the highest and lowest channels of operation were at least 20 dB below the in-band signal.

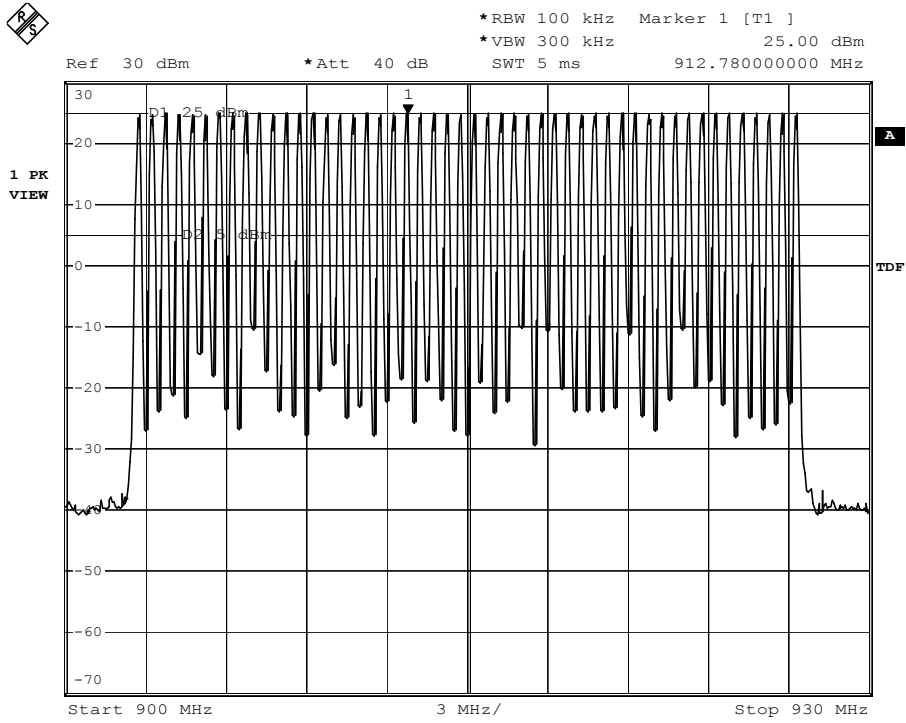

Figure 36. In band emissions at antenna port; 900 MHz - 930 MHz.

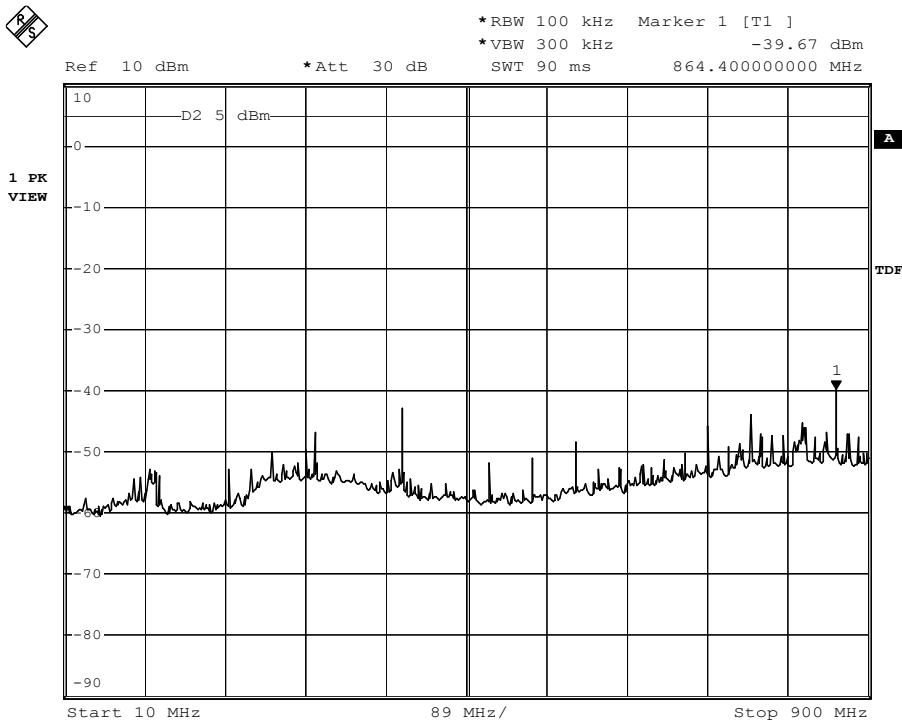

Figure 37. Out of band emissions at antenna port; 10 MHz - 900 MHz.

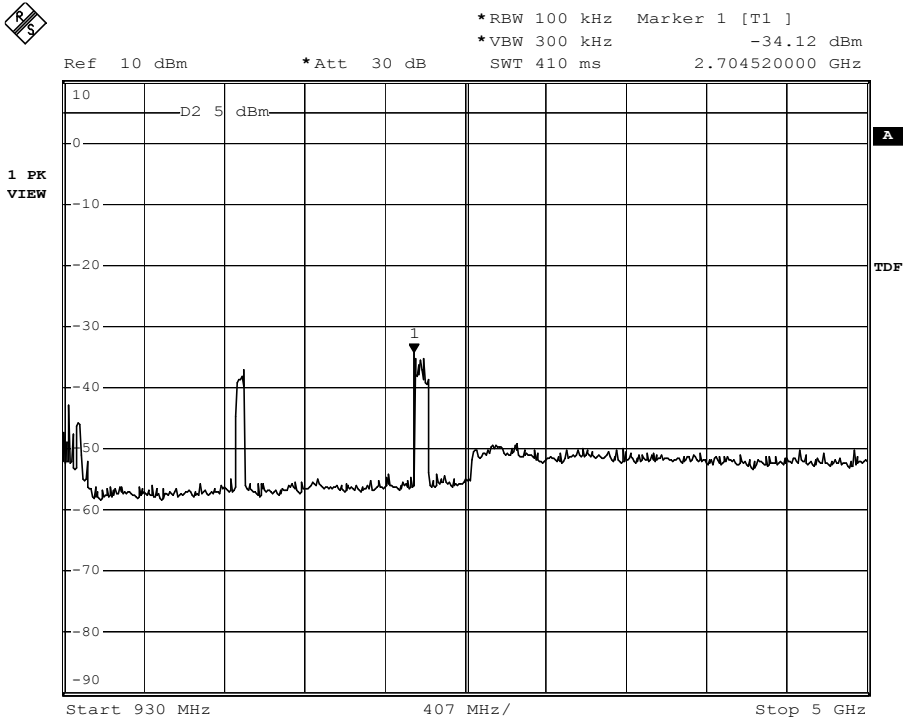

Figure 38. Out of band emissions at antenna port; 930 MHz - 5 GHz.

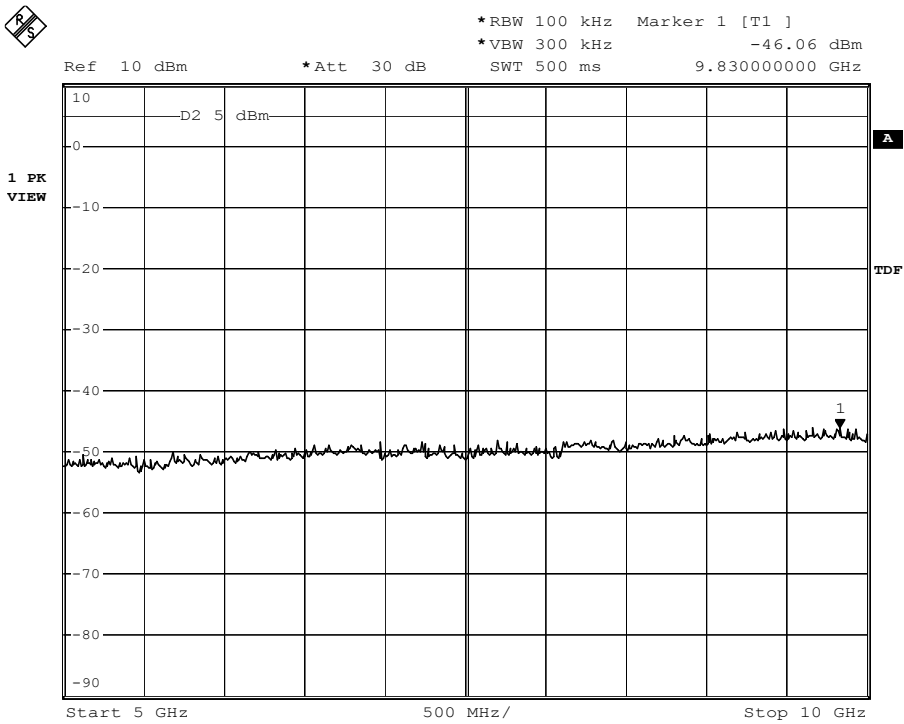

Figure 39. Out of band emissions at antenna port; 5 GHz - 10 GHz.

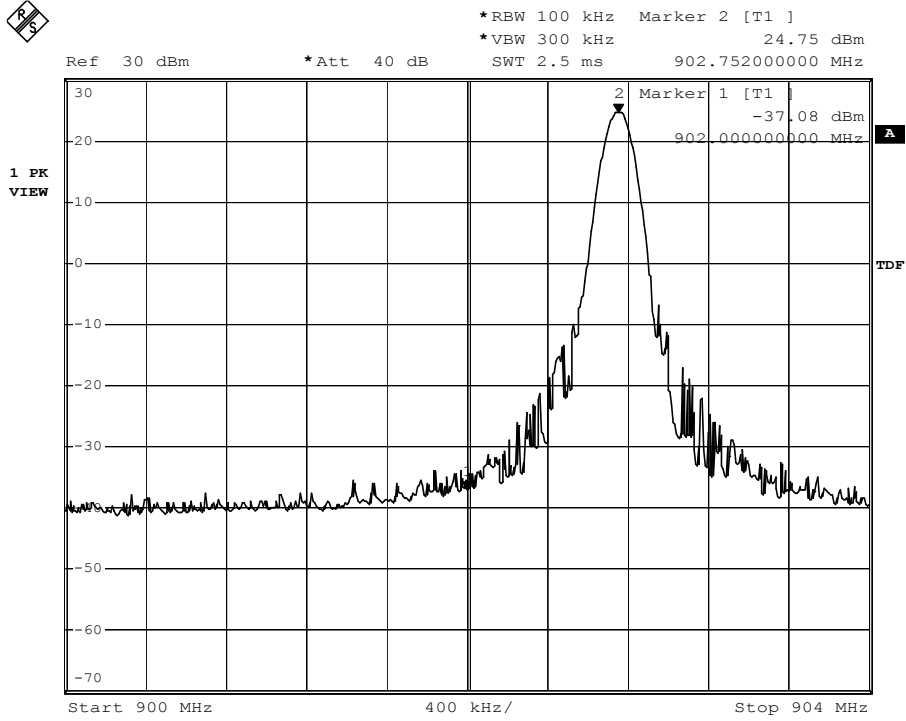

Figure 40. Band edge compliance; EPC Gen2 mode; Channel 1, hopping disabled.

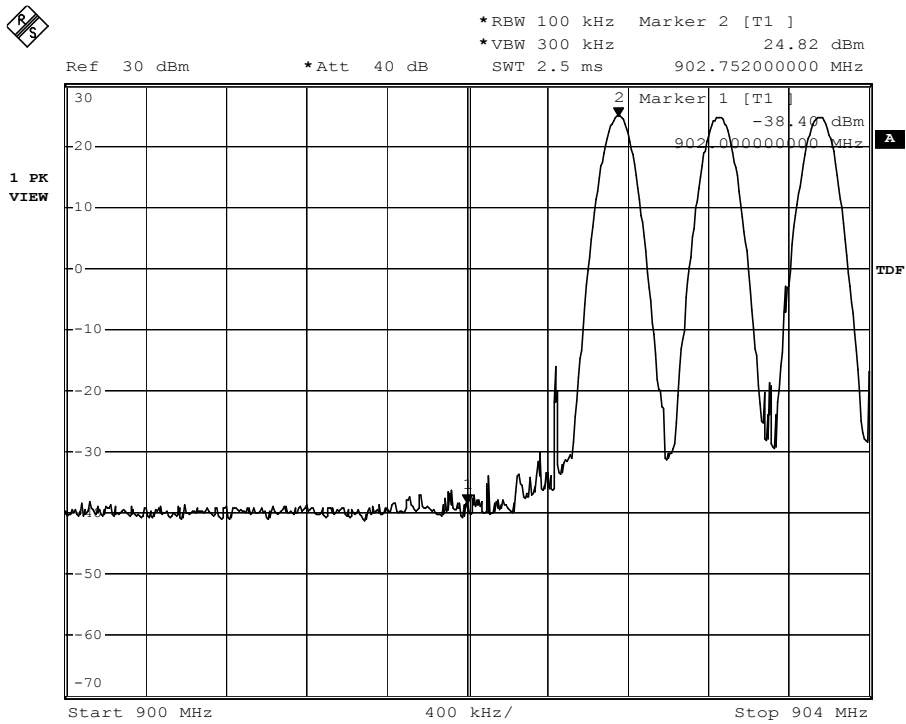

Figure 41. Band edge compliance; EPC Gen2 mode; Channel 1, hopping enabled.

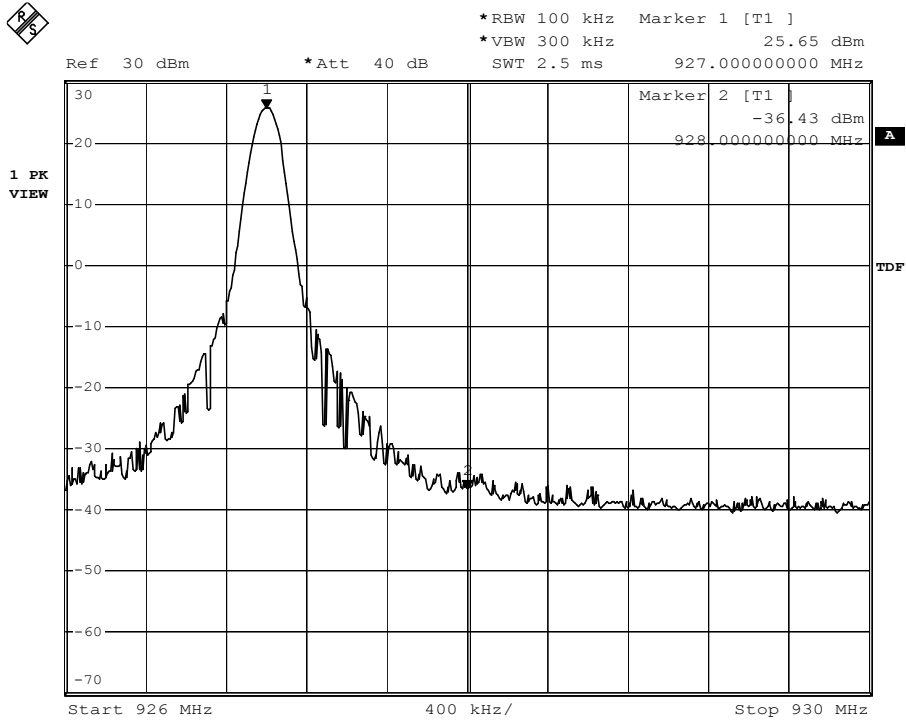

Figure 42. Band edge compliance; EPC Gen2 mode; Channel 50, hopping disabled.

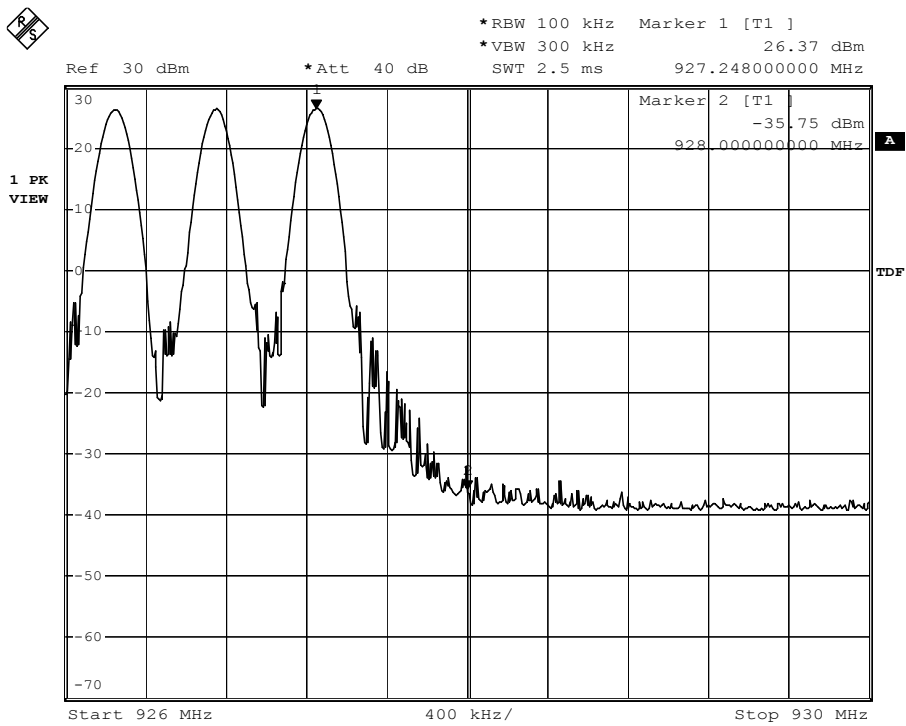

Figure 43. Band edge compliance; EPC Gen2 mode; Channel 50, hopping enabled.

8.7 RADIATED SPURIOUS EMISSIONS

Criteria for Radiated Spurious Emissions: The radiated spurious emissions of the transmitter shall not exceed the values in Table 3.

Frequency Range (MHz)	Limit (dB(μ V/m))	Measurement Distance (m)
1.705 - 30	29.5	30
30 - 88	40	3
88 - 216	43.5	3
216 - 960	46	3
960 - 1000	54	3
Above 1000	54 (average detector) 74 (peak detector)	3

Table 3. Limits for spurious emissions.

Test Procedure for Radiated Spurious Emissions: Radiated spurious emissions were measured in Lexmark's 3 meter semi-anechoic chamber. This facility is registered with the FCC (registration number 991141) and Industry Canada (reference file number 2376A-3).

The EUT configuration shown in Section 5 was placed atop a 0.8 meter high wooden table with a rectangular surface measuring 1.5m x 1.0m. The test setup is shown in Figures 44 and 45.

The receiving antenna was connected to a spectrum analyzer. The insertion loss of the interconnecting coaxial cable and antenna factors were stored as transducer factors in the spectrum analyzer and automatically accounted for in the readings. While the spectrum analyzer was in peak hold mode, the EUT configuration was rotated continuously and the antenna scanned from 1 - 4 meters in height. After obtaining a plot of the peak emissions, those emissions close to the limit were investigated using either the quasi-peak or average detector, as required.

For measurements below 30 MHz, a calibrated loop antenna was used. The antenna was located 10 meters from the EUT with a height of the center of the loop antenna at 1 meter. The axis of the antenna was rotated to maximize the emissions. Since the limits in Table 3 for emissions below 30 MHz are specified at 30 meters, and measurements were made at 10 meters, the limit is translated to 10 meters by using a $1/r^2$ relationship, or 40 dB/decade.

The EUT was exercised by continuously transmitting with the hopping function enabled. The output power of the EUT was set to the maximum (26 dBm) and was also tested at 15 dBm, the lowest power level expected to be used. During this testing, the printer was also printing so that this unintentional radiator mode was tested. In addition, the idle or standby mode was also tested.

Results for Radiated Spurious Emissions: Tables 4 - 9 contain data on the radiated spurious emissions of significant amplitude from the EUT configuration shown in Section 5. The frequency range from 16 MHz - 10 GHz was investigated for spurious emissions. This data indicates that the EUT met the requirements for radiated spurious emissions. The EUT also met the FCC Class B limits specified for unintentional radiators.

Frequency (MHz)	Polarity	Cable Loss (dB)	Antenna Factor (dB(1/m))	Amplitude (dB(μ V/m))	Limit (dB(μ V/m))	Margin (dB)
30.64	V	-22.2	18.7	33.4	40	6.6
51.301	V	-21.8	7.7	30.2	40	9.8
87.382	H	-21.5	8.5	32.4	40	7.6
139.162	H	-21.1	11.1	34.7	43.5	8.8
157.186	H	-20.9	10.4	37.3	43.5	6.2
158.178	H	-21.0	10.4	36.5	43.5	7.0

Table 4. Results for radiated spurious emissions < 1 GHz; transmitting; 26 dBm power setting.

Frequency (MHz)	Polarity	Correction Factors (dB)	Antenna Factor (dB(1/m))	Quasi-peak Amplitude (dB(μ V))	Quasi-peak Limit (dB(μ V))	Quasi-peak Margin (dB)	Average Amplitude (dB(μ V))	Average Limit (dB(μ V))	Average Margin (dB)
1499.1	V	-22.5	24.3	46.9	74	27.1	34.1	54	19.9
2024.1	V	-26.7	25.9	38.2	74	35.8	18.4	54	35.6
2407.4	H	-26.6	27.5	48.5	74	25.5	17.5	54	36.5
2998.3	V	-25.2	30.0	41.7	74	32.3	26.9	54	27.1
5974.5	H	-22.9	36.7	40.0	74	34.0	26.2	54	27.8
6006.9	V	-22.8	36.8	39.9	74	34.1	25.6	54	28.4

Table 5. Results for radiated spurious emissions > 1 GHz; transmitting; 26 dBm power setting.

Frequency (MHz)	Polarity	Cable Loss (dB)	Antenna Factor (dB(1/m))	Amplitude (dB(μ V/m))	Limit (dB(μ V/m))	Margin (dB)
30.648	V	-22.2	18.6	32.3	40	7.7
51.953	V	-21.8	7.4	34.3	40	5.7
87.823	H	-21.5	8.6	30.3	40	9.7
139.19	H	-21.1	11.1	34.6	43.5	8.9
159.2	H	-21	10.3	37.2	43.5	6.3
342.531	V	-19.7	14.4	33.4	46	12.6

Table 6. Results for radiated spurious emissions < 1 GHz; transmitting; 15 dBm power setting.

Frequency (MHz)	Polarity	Correction Factors (dB)	Antenna Factor (dB(1/m))	Quasi-peak Amplitude (dB(μ V))	Quasi-peak Limit (dB(μ V))	Quasi-peak Margin (dB)	Average Amplitude (dB(μ V))	Average Limit (dB(μ V))	Average Margin (dB)
1496.5	H	-22.5	24.3	40.2	74	33.8	26.2	54	27.8
1499.2	V	-22.5	24.3	43.3	74	30.7	30.1	54	23.9
2774.7	H	-25.8	29.1	42.7	74	31.3	17.6	54	36.4
2997.4	V	-25.2	30.0	39.6	74	34.4	24.5	54	29.5
3315.2	V	-24.4	30.3	37.5	74	36.5	23.8	54	30.2
5974.7	H	-22.9	36.7	39.2	74	34.8	25.7	54	28.3

Table 7. Results for radiated spurious emissions > 1 GHz; transmitting; 15 dBm power setting.

Frequency (MHz)	Polarity	Cable Loss (dB)	Antenna Factor (dB(1/m))	Amplitude (dB(μV/m))	Limit (dB(μV/m))	Margin (dB)
30.689	V	-22.2	18.6	35.7	40	4.34
31.501	V	-22.2	18.2	36.6	40	3.44
78.354	H	-21.5	7.4	30.3	40	9.7
155.308	H	-20.8	10.4	34.9	43.5	8.6
167.967	H	-20.9	9.8	31.5	43.5	12.0
342.654	V	-19.7	14.4	33.7	46	12.3

Table 8. Results for radiated spurious emissions < 1 GHz; standby mode.

Frequency (MHz)	Polarity	Correction Factors (dB)	Antenna Factor (dB(1/m))	Quasi-peak Amplitude (dB(μV))	Quasi-peak Limit (dB(μV))	Quasi-peak Margin (dB)	Average Amplitude (dB(μV))	Average Limit (dB(μV))	Average Margin (dB)
1498.5	H	-22.5	24.3	40.9	74	33.1	27.6	54	26.4
1499.5	V	-22.5	24.3	44.8	74	29.2	30.3	54	23.7
2024.0	V	-26.7	25.9	34.9	74	39.1	14.9	54	39.1
2455.4	V	-26.6	27.7	37.7	74	36.3	16.0	54	38.0
2998.9	V	-25.2	30.0	39.8	74	34.2	23.6	54	30.4
3321.8	V	-24.4	30.3	38.7	74	35.3	21.3	54	32.5

Table 9. Results for radiated spurious emissions > 1 GHz; standby mode.



Figure 44. Test configuration for transmitter spurious emissions (front view).

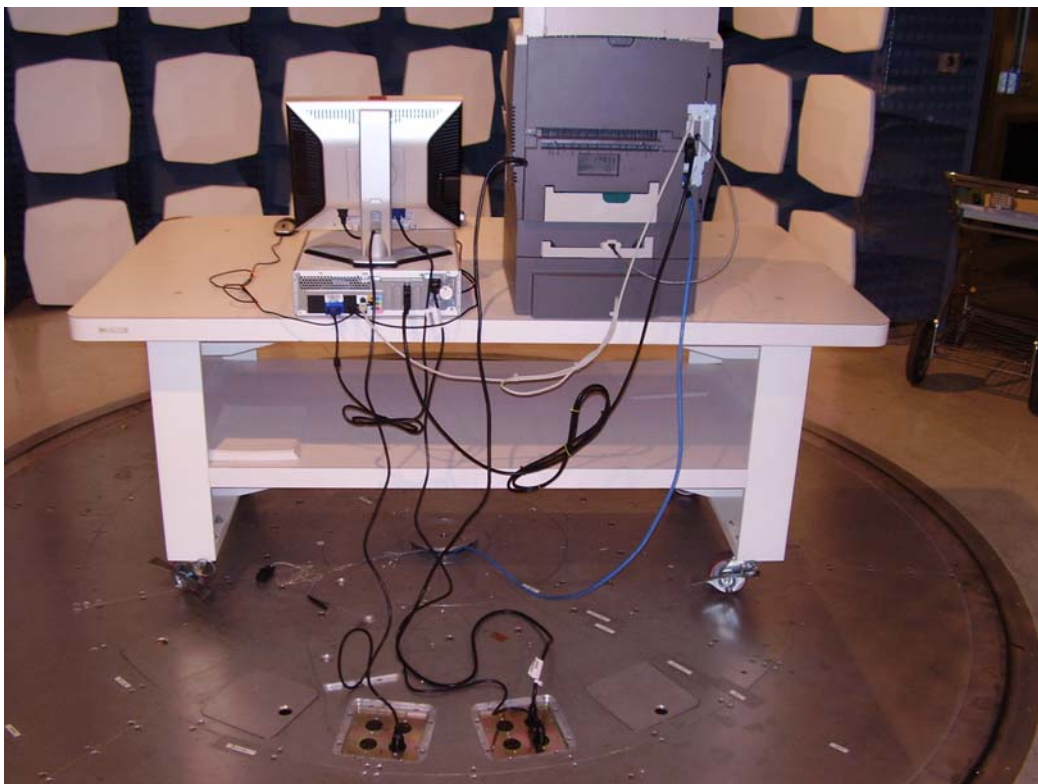

Figure 45. Test configuration for transmitter spurious emissions (back view).

8.8 CONDUCTED EMISSIONS

Criteria for Conducted Emissions [1]: The emissions conducted onto the AC power line by the EUT shall not exceed the values in Table 10.

Frequency Range (MHz)	Quasi-peak Limit (dB(μ V))	Average Limit (dB(μ V))
0.15 - 0.5	66 to 56	56 to 46
0.5 - 5	56	46
5 - 30	60	50

Table 10. Limits for conducted emissions.

Test Procedure for Conducted Emissions: The test configuration shown in Figures 46 and 47 was used for this testing. Conducted emissions testing was performed in an 18 ft. x 18 ft. all-welded shielded room located at Lexmark International's EMC test facilities.

The EUT configuration shown in Section 5 was placed atop a 0.8 meter high wooden table with a rectangular surface measuring 1.5m x 1.0m. The back edges of all devices were located 40 cm from the metal wall of the shielded room.

The AC line cord of the EUT was plugged into the LISN (Line Impedance Stabilization Network) with the excess of the EUT line cord length bundled in the center. The USB, parallel and network cables were draped down from the rear of the EUT and PC, but hung no closer than 40 cm to the floor (ground plane). The excess of these cables were serpentine to form a bundle 30-40 cm in length, with the overall length of the cable not to exceed 1.0 meter in length

The EUT was exercised by continuously transmitting with the hopping enabled at the highest power setting and in the standby mode. During this testing, the printer was also printing so that this unintentional radiator mode was tested.

Results for Conducted Emissions: Tables 11 - 12 contain the conducted emission results when transmitting and in the standby mode. The EUT met the requirements for conducted emissions given in Table 10. The EUT also met the FCC Class B limits specified for unintentional radiators.

Frequency (MHz)	Line	Correction Factors (dB)	Quasi-peak Amplitude (dB(μV))	Quasi-peak Limit (dB(μV))	Quasi-peak Margin (dB)	Average Amplitude (dB(μV))	Average Limit (dB(μV))	Average Margin (dB)
0.152	P	11.0	46.3	66.0	19.6	17.9	56.0	38.0
0.191	P	10.5	52.3	64.8	12.5	50.0	54.8	4.8
0.317	P	10.2	45.8	61.2	15.5	42.5	51.2	8.7
0.317	N	10.2	48.9	61.2	12.3	42.4	51.2	8.9
0.38	P	10.2	44.8	59.4	14.7	38.6	49.4	10.8
0.444	N	10.2	45.0	57.6	12.6	33.6	47.6	14.0

Table 11. Results for conducted emissions; transmitting with hopping enabled.

Frequency (MHz)	Line	Correction Factors (dB)	Quasi-peak Amplitude (dB(μV))	Quasi-peak Limit (dB(μV))	Quasi-peak Margin (dB)	Average Amplitude (dB(μV))	Average Limit (dB(μV))	Average Margin (dB)
0.19	P	10.6	52.5	64.9	12.3	45.0	54.9	9.9
0.253	P	10.1	44.0	63.1	19.1	39.6	53.1	13.5
0.316	P	10.2	42.9	61.3	18.3	34.9	51.3	16.3
0.507	P	10.3	35.2	56	20.8	27.3	46	18.7
1.14	N	10.3	28.8	56	27.2	19.0	46	27.0
1.774	N	10.4	27.9	56	28.1	21.0	46	25.1

Table 12. Results for conducted emissions; standby mode.



Figure 46. Test configuration for transmitter conducted emissions (front view).



Figure 47. Test configuration for transmitter conducted emissions (side view).

8.9 MAXIMUM PERMISSIBLE EXPOSURE CALCULATIONS

Test Procedure for Maximum Permissible Exposure: Using the power measurements previously reported in this report, the power density at a distance of 20 cm from the EUT must be calculated.

The power density at a distance d from an antenna can be calculated from the following equation:

$$s = \frac{P_{inc} G}{4\pi d^2}$$

where P_{inc} is the power incident to the antenna and G is the gain of the antenna. From the conducted power measurements previously reported, the maximum for all modes of operation is 26.09 dBm (406.4 mW). Given the gain of the antenna to be -14.3 dBi (0.0372), the power density at a distance of 20 cm from the EUT is given by:

$$s = \frac{(406.4mW)(0.0372)}{4\pi(20cm)^2} = \frac{0.003mW}{cm^2}$$

It is expected that due to the nature of the EUT, the user will be located at least 20 cm from the EUT.

Criteria for Maximum Permissible Exposure: Per §1.1310 of the FCC Rules, the limit of radiation exposure for a device operating in the frequency range of 902 - 928 MHz under the Limits for General Population/Uncontrolled Exposure, the maximum power density is 0.61 mW/cm². The EUT was well below this value for separation distances of 20 cm or greater.

NOTE:

The following conditions apply to this report:

This report shall not be --

- 1. reproduced without the permission of the Lexmark EMC Department, nor**
- 2. reproduced, except in full.**