



T640rn

User's Guide

June 2006

www.lexmark.com

Lexmark and Lexmark with diamond design are trademarks of Lexmark International, Inc., registered in the United States and/or other countries. All other trademarks are the property of their respective owners.

© 2006 Lexmark International, Inc.

All rights reserved.

740 West New Circle Road
Lexington, Kentucky 40550

Safety information

Connect the power supply cord to a properly grounded electrical outlet that is near the product and easily accessible.

Connect the power supply cord to an electrical outlet that is near the product and easily accessible.

Refer service or repairs, other than those described in the user documentation, to a professional service person.

This product is designed, tested, and approved to meet strict global safety standards with the use of specific Lexmark components. The safety features of some parts may not always be obvious. Lexmark is not responsible for the use of other replacement parts.

 **CAUTION:** Make sure that all external connections (such as Ethernet and telephone system connections) are properly installed in their marked plug-in ports.

This product uses a laser.

 **CAUTION:** Use of controls or adjustments or performance of procedures other than those specified herein may result in hazardous radiation exposure.

This product uses a printing process that heats the print media, and the heat may cause the media to release emissions. You must understand the section in your operating instructions that discusses the guidelines for selecting print media to avoid the possibility of harmful emissions.

This product uses a printing process that produces ozone. You must understand the section in your operating instructions that discusses the precautions to take to limit ozone concentration.

This product contains mercury in the lamp (<5mg Hg). Disposal of mercury may be regulated due to environmental considerations. For disposal or recycling information, contact your local authorities or the Electronic Industries Alliance: www.eiae.org.

This symbol indicates the presence of a hot surface or component.

 **CAUTION:** To reduce the risk of injury from a hot component, allow the surface to cool before touching.

Contents

Introduction.....	5
Overview of Radio Frequency Identification (RFID).....	5
Choosing an output device.....	5
Preparing to print.....	6
Loading RFID labels.....	6
Printing.....	8
Printing on labels of different sizes.....	8
Identifying rejected labels.....	8
Understanding the RFID menu.....	9
Configuring RFID-specific settings.....	9
Understanding RFID printer messages.....	11
RFID error messages.....	11
RFID service messages.....	12
Notices.....	13
Power consumption.....	15
Index.....	18

Introduction

Overview of Radio Frequency Identification (RFID)

Radio Frequency Identification (RFID) is an automatic identification method that relies on storing and retrieving data using RFID tags. The tags, which are incorporated into labels, receive and respond to radio-frequency queries from an RFID transceiver. This tag support lets you print on labels and simultaneously program embedded RFID tags.

Choosing an output device

Output devices used in printing labels include the 5-bin mailbox, the output expander, the high-capacity output stacker, adjustable stacker, and the finisher staplesmart. Choose an output device based on the software program, the length of label needed, and the number of labels that you expect to print at one time. To order an output device, visit the Lexmark Web site at www.lexmark.com:

Output device	Part number
5-bin Mailbox	20G0895
Output expander	20G0894
High-capacity output stacker	20G0896
Adjustable stacker	20G1360
Finisher StapleSmart	20G0897

Note: RFID media should not be directed to the T64x StapleSmart Finisher, if it is used as an output device. The standard output bin should be used for all RFID media, even if recognized as defective. The T64x StapleSmart Finisher may still be used for any non-RFID media.

Preparing to print

Loading RFID labels

To load labels:

Note: Do not remove a tray when a job is printing or when the operator panel indicator light is blinking. Doing so may cause a jam.

- 1 Remove the tray from the printer, and place it on a flat, level surface.
- 2 Squeeze the side guard tab, and slide the guide to the outer edge of the tray.

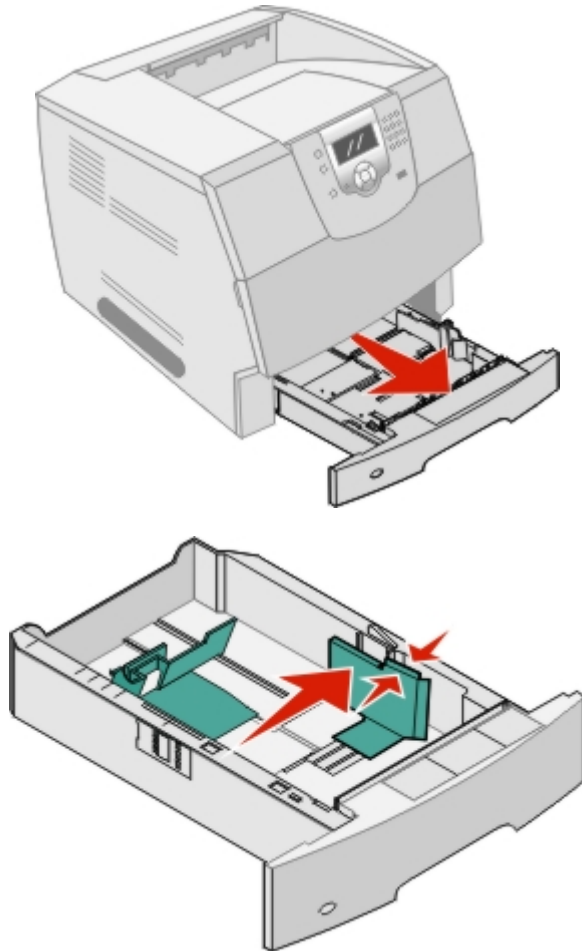

- 3 Flex the label sheets back and forth to loosen them, and then fan them. Do not fold or crease the label sheets. Straighten the edges on a level surface.
- 4 Place the label sheets with the print side facing down and the labels positioned at the back of the tray.
- 5 Squeeze the rear guide tab, and slide the guide to the correct position for the size label sheets you are loading.
- 6 Insert the tray into the printer.

The increased thickness of RFID labels reduces the input and output bin capacity. Test your software program to ensure that you understand the reduced input and output bin capabilities. For information on label construction, see the *Card Stock and Label Guide* on the Lexmark Web site at www.lexmark.com/publications.

Proper tag orientation for printing

The following are examples of tag locations known to work correctly:

Tag manufacturer (EPC class 1 generation 2 specification only)	Tag location	Orientation
Symbol G2 4 x 4	1.5–8.5 in. from the left edge	NA
Rafaltec	3.7–7.5 in from the left edge	Parallel to the long edge of the label sheet
Avery Dennison	3.7–7.5 in. from the left edge	Parallel to the long edge of the label sheet
Texas Instruments	4.7–7.8 in. from the left edge	Parallel to the long edge of the label sheet
Alien	3.7–7.5 in from the left edge	Parallel to the long edge of the label sheet

Notes:

- Tags must be built to EPC class 1 generation 2 specifications.
- A tag must be located within the first two-thirds of the label sheet.

Printing

Printing on labels of different sizes

Label size/type	Input options	Output options	Rejected label output
Less than 7 in.	250-sheet tray	<ul style="list-style-type: none"> • 5-bin Mailbox • Output expander • High-capacity output stacker • Adjustable stacker 	Set the default Reject Bin so that all rejected labels are sent to the same output device. <ol style="list-style-type: none"> 1 Select RFID Settings using the Menu button. 2 Select Reject Bin. 3 Select one of the listed output bins to use as the default. 4 Exit the menu.
Less than 9 in.	Any tray		
9–14 in.	Any tray		

Identifying rejected labels

When a label is rejected, a printed grid appears at the bottom of the label sheet as shown in the following diagram. However, this only applies to label sheets greater than 9 inches.

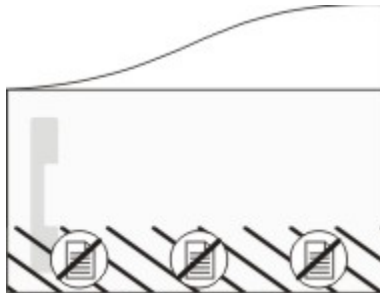

Understanding the RFID menu

Configuring RFID-specific settings

The RFID menu is used to configure RFID-specific settings. It is located on the operator panel between the Help and Network/Ports menus.

Note: RFID settings appear on the menu settings page. For information on printing a menu settings page, see the User's Guide available on the *Software and Documentation CD*.



Press  to access the Menu options. Select RFID Menu from the list.

The RFID Menu setting appears.

RFID Settings

Retry Count

Stop on Error

Mark on Error

Reset Label Count

RFID settings menu

Use the "RFID" Menu to define the following:

- Labels loaded in each label tray
- Default label source
- Output bin

Retry count

Menu selection	Purpose	Option	Comments
Retry Count	Determines how many times to retry programming a new label when label fails to program. A retry will occur on a new RFID sheet	0–255	Zero is the default value.

Stop on Error

Menu selection	Purpose	Option	Comments
Stop on Error	Determines whether or not to stop printing and post a message on the operator panel when the Retry County is exhausted	Yes No	Yes is the default value.

Reject Bin

Menu selection	Purpose	Option	Comments
Reject Bin	Determines where to send sheets with RFID labels that failed to program correctly Standard Bin and Disabled are displayed if no option bins are installed	Disabled Standard Bin Bin 1 Bin 2 Bin 3 Bin 4 Bin 5 Bin 6 Bin 7 Bin 8 Bin 9 Bin 10	Disabled is the default value.

Mark on Error

Menu selection	Purpose	Option	Comments
Mark on Error	Tells the printer to print a grid on the bottom of any media when a defective label is detected	Yes No	Yes is the default value.

Reset Label Counters

Menu selection	Purpose	Option	Comments
Reset Label Counters	Clears the current version of label counters (passed and failed). Reset is the only menu selection	Value Reset	When Reset is selected, a "Contents will be lost" confirmation prompt appears.

Understanding RFID printer messages

RFID error messages

Message	Action
44.00 RFID error (generic)	<ol style="list-style-type: none"> 1 Turn the printer off. 2 Unplug the power cord. 3 Check all cable connections. 4 Connect the power cord to a grounded outlet. 5 Turn the printer on. 6 If the message recurs, call for service, and report the message number and a description of the problem.
44.01 Bad tag error	<ul style="list-style-type: none"> • Cancel the current job and reprint. • Contact the software program solution provider if the percentage of failure seems high.
44.11 Data is bad	
44.12 Missing bytes in subcommand	
44.13 Too many bytes in subcommand	
44.14 Generic invalid argument error	
44.15 Invalid magic number	
44.16 Known but unsupported magic number	
44.17 Illegal characters in subcommand	
44.18 Invalid opcode	
44.19 Valid but unsupported opcode	
44.20 Invalid protocol	
44.21 Valid but unsupported protocol	
44.22 Operation not supported by reader	
44.23 Invalid ID length for given protocol	
44.24 Invalid ID bit pattern for given protocol	
44.25 Too many tags on page	
44.26 Tag location parameters invalid	
44.31 Generic run-time reader error	
44.32 Reader response timeout	
44.33 Garbled or short response from reader	
44.34 Read/verify operation failed	

RFID service messages

Message	Action
902.81 Service engine software error	<ol style="list-style-type: none">1 Turn the printer off.2 Unplug the power cord.3 Check all cable connections.4 Connect the power cord to a properly grounded outlet.5 Turn the printer on.6 If the service message recurs, call for service, and report the message number and a description of the problem.
985.01 Unable to communicate with interface card	
985.02 Unable to communicate with radio	
985.03 Radio fails internal self test	
985.04 Antenna appears disconnected	
985.05 Radio firmware flash upgrade failed	

Notices

Product name	T640rn
Model number	4061
Machine type	OR0

Edition notice

July 2006

The following paragraph does not apply to any country where such provisions are inconsistent with local law: LEXMARK INTERNATIONAL, INC., PROVIDES THIS PUBLICATION “AS IS” WITHOUT WARRANTY OF ANY KIND, EITHER EXPRESS OR IMPLIED, INCLUDING, BUT NOT LIMITED TO, THE IMPLIED WARRANTIES OF MERCHANTABILITY OR FITNESS FOR A PARTICULAR PURPOSE. Some states do not allow disclaimer of express or implied warranties in certain transactions; therefore, this statement may not apply to you.

This publication could include technical inaccuracies or typographical errors. Changes are periodically made to the information herein; these changes will be incorporated in later editions. Improvements or changes in the products or the programs described may be made at any time.

Comments about this publication may be addressed to Lexmark International, Inc., Department F95/032-2, 740 West New Circle Road, Lexington, Kentucky 40550, U.S.A. Lexmark may use or distribute any of the information you supply in any way it believes appropriate without incurring any obligation to you. To obtain additional copies of publications related to this product, visit the Lexmark Web site at www.lexmark.com.

References in this publication to products, programs, or services do not imply that the manufacturer intends to make these available in all countries in which it operates. Any reference to a product, program, or service is not intended to state or imply that only that product, program, or service may be used. Any functionally equivalent product, program, or service that does not infringe any existing intellectual property right may be used instead. Evaluation and verification of operation in conjunction with other products, programs, or services, except those expressly designated by the manufacturer, are the user’s responsibility.

© 2006 Lexmark International, Inc.

All rights reserved.

UNITED STATES GOVERNMENT RIGHTS

This software and any accompanying documentation provided under this agreement are commercial computer software and documentation developed exclusively at private expense.

Trademarks

Lexmark and Lexmark with diamond design are trademarks of Lexmark International, Inc., registered in the United States and/or other countries.

All other trademarks are the property of their respective owners.

Conventions

Note: A *Note* identifies something that could help you.

Warning: A *Warning* identifies something that could damage your product hardware or software.



CAUTION: A *CAUTION* identifies something that could cause you harm.



CAUTION: This type of *CAUTION* indicates that you should *not touch* the marked area.



CAUTION: This type of *CAUTION* indicates a *hot surface*.



CAUTION: This type of *CAUTION* indicates a *shock hazard*.



CAUTION: This type of *CAUTION* indicates a *tipping hazard*.

Federal Communications Commission (FCC) compliance information statement

This product has been tested and found to comply with the limits for a Class B digital device, pursuant to Part 15 of the FCC Rules. Operation is subject to the following two conditions: (1) this device may not cause harmful interference, and (2) this device must accept any interference received, including interference that may cause undesired operation.

The FCC Class B limits are designed to provide reasonable protection against harmful interference when the equipment is operated in a residential installation. This equipment generates, uses, and can radiate radio frequency energy and, if not installed and used in accordance with the instructions, may cause harmful interference to radio communications. However, there is no guarantee that interference will not occur in a particular installation. If this equipment does cause harmful interference to radio or television reception, which can be determined by turning the equipment off and on, the user is encouraged to try to correct the interference by one or more of the following measures:

- Reorient or relocate the receiving antenna.
- Increase the separation between the equipment and receiver.
- Connect the equipment into an outlet on a circuit different from that to which the receiver is connected.
- Consult your point of purchase or service representative for additional suggestions.

The manufacturer is not responsible for radio or television interference caused by using other than recommended cables or by unauthorized changes or modifications to this equipment. Unauthorized changes or modifications could void the user's authority to operate this equipment.

Note: To assure compliance with FCC regulations on electromagnetic interference for a Class B computing device, use a properly shielded and grounded cable such as Lexmark part number 1021294 for USB attach. Use of a substitute cable not properly shielded and grounded may result in a violation of FCC regulations.

Any questions regarding this compliance information statement should be directed to:

Director of Lexmark Technology & Services
Lexmark International, Inc.
740 West New Circle Road
Lexington, KY 40550
(859) 232-3000

Industry Canada compliance statement

This Class B digital apparatus meets all requirements of the Canadian Interference-Causing Equipment Standard ICES-003.

Avis de conformité aux normes de l'industrie du Canada

Cet appareil numérique de classe B est conforme aux exigences de la norme canadienne relative aux équipements pouvant causer des interférences NMB-003.

Exposure to radio frequency radiation

The radiated output power of this device is far below the FCC radio frequency exposure limits. A minimum separation of 20 cm (8 inches) must be maintained between the antenna and any persons for this device to satisfy the RF exposure requirements of the FCC.

Noise emission levels

The following measurements were made in accordance with ISO 7779 and reported in conformance with ISO 9296.

Note: Some modes may not apply to your product.

1-meter average sound pressure, dBA	
Printing	53 dB
Ready	30 dB

Values are subject to change. See www.lexmark.com for current values.

ENERGY STAR



Laser notice

The printer is certified in the U.S. to conform to the requirements of DHHS 21 CFR Subchapter J for Class I (1) laser products, and elsewhere is certified as a Class I laser product conforming to the requirements of IEC 60825-1.

Class I laser products are not considered to be hazardous. The printer contains internally a Class IIIb (3b) laser that is nominally a 5 milliwatt gallium arsenide laser operating in the wavelength of 770-795 nanometers. The laser system and printer are designed so there is never any human access to laser radiation above a Class I level during normal operation, user maintenance, or prescribed service condition.

Laser advisory label

A laser notice label may be affixed to this printer as shown:

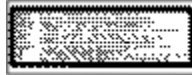

Power consumption

Product power consumption

The following table documents the power consumption characteristics of the product.

Note: Some modes may not apply to your product.

Mode	Description	Power consumption (Watts)
Printing	The product is generating hard-copy output from electronic inputs.	525 W
Copying	The product is generating hard-copy output from hard-copy original documents.	N/A
Scanning	The product is scanning hard-copy documents.	N/A
Ready	The product is waiting for a print job.	90 W
Power Saver	The product is in energy-saving mode.	20 W
High Off	The product is plugged into a wall outlet, but the power switch is turned off.	N/A
Low Off (<1 W Off)	The product is plugged into a wall outlet, the power switch is turned off, and the product is in the lowest possible power consumption mode.	N/A
Off	The product is plugged into a wall outlet, but the power switch is turned off.	0 W

The power consumption levels listed in the previous table represent time-averaged measurements. Instantaneous power draws may be substantially higher than the average.

Values are subject to change. See www.lexmark.com for current values.

Power Saver

This product is designed with an energy-saving mode called Power Saver. The Power Saver Mode is equivalent to the EPA Sleep Mode. The Power Saver Mode saves energy by lowering power consumption during extended periods of inactivity. The Power Saver Mode is automatically engaged after this product is not used for a specified period of time, called the Power Saver Timeout.

Factory default Power Saver Timeout for this product (in minutes):	30 Minutes
--	------------

By using the configuration menus, the Power Saver Timeout can be modified between 1 minute and 240 minutes. Setting the Power Saver Timeout to a low value reduces energy consumption, but may increase the response time of the product. Setting the Power Saver Timeout to a high value maintains a fast response, but uses more energy.

Off mode

If this product has an off mode which still consumes a small amount of power, then to completely stop product power consumption, disconnect the power supply cord from the wall outlet.

Total energy usage

It is sometimes helpful to calculate the total product energy usage. Since power consumption claims are provided in power units of Watts, the power consumption should be multiplied by the time the product spends in each mode in order to calculate energy usage. The total product energy usage is the sum of each mode's energy usage.

Statement of Limited Warranty

T640m

Lexmark International, Inc., Lexington, KY

This limited warranty applies to the United States and Canada. For customers outside the U.S., refer to the country-specific warranty information that came with your product.

This limited warranty applies to this product only if it was originally purchased for your use, and not for resale, from Lexmark or a Lexmark Remarketer, referred to in this statement as "Remarketer."

Limited warranty

Lexmark warrants that this product:

- Is manufactured from new parts, or new and serviceable used parts, which perform like new parts
- Is, during normal use, free from defects in material and workmanship

If this product does not function as warranted during the warranty period, contact a Remarketer or Lexmark for repair or replacement (at Lexmark's option).

If this product is a feature or option, this statement applies only when that feature or option is used with the product for which it was intended. To obtain warranty service, you may be required to present the feature or option with the product.

If you transfer this product to another user, warranty service under the terms of this statement is available to that user for the remainder of the warranty period. You should transfer proof of original purchase and this statement to that user.

Limited warranty service

The warranty period starts on the date of original purchase as shown on the purchase receipt and ends 12 months later provided that the warranty period for any supplies and for any maintenance items included with the printer shall end earlier if it, or its original contents, are substantially used up, depleted, or consumed.

To obtain warranty service you may be required to present proof of original purchase. You may be required to deliver your product to the Remarketer or Lexmark, or ship it prepaid and suitably packaged to a Lexmark designated location. You are responsible for loss of, or damage to, a product in transit to the Remarketer or the Lexmark designated location.

When warranty service involves the exchange of a product or part, the item replaced becomes the property of the Remarketer or Lexmark. The replacement may be a new or repaired item.

The replacement item assumes the remaining warranty period of the original product.

Replacement is not available to you if the product you present for exchange is defaced, altered, in need of a repair not included in warranty service, damaged beyond repair, or if the product is not free of all legal obligations, restrictions, liens, and encumbrances.

Before you present this product for warranty service, remove all print cartridges, programs, data, and removable storage media (unless directed otherwise by Lexmark).

For further explanation of your warranty alternatives and the nearest Lexmark authorized servicer in your area contact Lexmark on the World Wide Web at www.lexmark.com/support.

Remote technical support is provided for this product throughout its warranty period. For products no longer covered by a Lexmark warranty, technical support may not be available or only be available for a fee.

Extent of limited warranty

Lexmark does not warrant uninterrupted or error-free operation of any product or the durability or longevity of prints produced by any product.

Warranty service does not include repair of failures caused by:

- Modification or unauthorized attachments
- Accidents, misuse, abuse or use inconsistent with Lexmark user's guides, manuals, instructions or guidance
- Unsuitable physical or operating environment
- Maintenance by anyone other than Lexmark or a Lexmark authorized servicer
- Operation of a product beyond the limit of its duty cycle
- Use of printing media outside of Lexmark specifications
- Refurbishment, repair, refilling or remanufacture by a third party of products, supplies or parts
- Products, supplies, parts, materials (such as toners and inks), software, or interfaces not furnished by Lexmark

TO THE EXTENT PERMITTED BY APPLICABLE LAW, NEITHER LEXMARK NOR ITS THIRD PARTY SUPPLIERS OR REMARKETERS MAKE ANY OTHER WARRANTY OR CONDITION OF ANY KIND, WHETHER EXPRESS OR IMPLIED, WITH RESPECT TO THIS PRODUCT, AND SPECIFICALLY DISCLAIM THE IMPLIED WARRANTIES OR CONDITIONS OF MERCHANTABILITY, FITNESS FOR A PARTICULAR PURPOSE, AND SATISFACTORY QUALITY. ANY WARRANTIES THAT MAY NOT BE DISCLAIMED UNDER APPLICABLE LAW ARE LIMITED IN DURATION TO THE WARRANTY PERIOD. NO WARRANTIES, EXPRESS OR IMPLIED, WILL APPLY AFTER THIS PERIOD. ALL INFORMATION, SPECIFICATIONS, PRICES, AND SERVICES ARE SUBJECT TO CHANGE AT ANY TIME WITHOUT NOTICE.

Limitation of liability

Your sole remedy under this limited warranty is set forth in this document. For any claim concerning performance or nonperformance of Lexmark or a Remarketer for this product under this limited warranty, you may recover actual damages up to the limit set forth in the following paragraph.

Lexmark's liability for actual damages from any cause whatsoever will be limited to the amount you paid for the product that caused the damages. This limitation of liability will not apply to claims by you for bodily injury or damage to real property or tangible personal property for which Lexmark is legally liable. **IN NO EVENT WILL LEXMARK BE LIABLE FOR ANY LOST PROFITS, LOST SAVINGS, INCIDENTAL DAMAGE, OR OTHER ECONOMIC OR CONSEQUENTIAL DAMAGES.** This is true even if you advise Lexmark or a Remarketer of the possibility of such damages. Lexmark is not liable for any claim by you based on a third party claim.

This limitation of remedies also applies to claims against any Suppliers and Remarketers of Lexmark. Lexmark's and its Suppliers' and Remarketers' limitations of remedies are not cumulative. Such Suppliers and Remarketers are intended beneficiaries of this limitation.

Additional rights

Some states do not allow limitations on how long an implied warranty lasts, or do not allow the exclusion or limitation of incidental or consequential damages, so the limitations or exclusions contained above may not apply to you.

This limited warranty gives you specific legal rights. You may also have other rights that vary from state to state.

Index

Numerics

44.xx 11
902.xx 12
985.xx 12

E

emission notices 14

F

FCC notices 14

I

identifying
rejected labels 8

L

labels
loading 6
printing 8
tag orientation 6
loading
labels 6

M

messages
RFID error 11
RFID service 12

N

noise emission levels 14
notices 13, 14, 15

O

output device
choosing 5

P

printer messages
44.xx 11
902.xx 12
985.xx 12
printing
labels 8

R

rejected labels
identifying 8
RFID menu
using 9

S

safety information 2

U

using the RFID menu 9