

Test of SpectraLink RNP2400 Telephone Device

To FCC 47 CFR Part 15.247/IC RSS -210

Test Report Serial No.:
TUVR03 Addendum/ REV A



TEST REPORT

FROM



Test of SpectraLink RNP2400 Telephone Device

To FCC 47 CFR Part 15.247/IC RSS-210

Test Report Serial No.:
TUVR04 Addendum/REV A

This report supersedes none

Remarks:

Equipment complied with the specification
Equipment did not comply with the specification

This Test Report is issued Under the Authority of:

A handwritten signature in black ink, appearing to read "Gordon Hurst", is written over a horizontal line.

Gordon Hurst President & CEO

Copy No: pdf

Issue date: 13th December '04

Equipment Details:

Manufacturer: SpectraLink Corporation
Type designation: refer to section 2 of test report
Serial No's: refer to section 5 of test report



This test report may be reproduced in full only

2106



Title: Test of SpectraLink RNP2400 Telephone
To: FCC 47 CFR Part 15.247/IC RSS-210
Serial #: TUVR04 Addendum/REV A
Issue Date: 13th December '04
Page: 2 of 15

This page has been left intentionally blank



Title: Test of SpectraLink RNP2400 Telephone
To: FCC 47 CFR Part 15.247/IC RSS-210
Serial #: TUVR04 Addendum/REV A
Issue Date: 13th December '04
Page: 3 of 15

CONTENTS

1	<i>Executive Summary</i>	4
2	<i>Technical Details</i>	5
3	<i>Test Summary</i>	6
	3.1 Test Configurations	6
	3.2 List of Measurements	7
4	<i>Summary Of Test Results</i>	8
5	<i>Measurements, Examinations and Derived Results</i>	9
	5.1 General observations	9
	5.1.1 Emission characteristics	10
6	<i>Photographs</i>	12
	6.1 AC Wireline Conducted Emission Test Setup	12
7	<i>Graphical Results</i>	13
8	<i>Test Equipment</i>	15

1 Executive Summary

The purpose of this test program was to demonstrate compliance of the RNP2400 SpectraLink Wireless Telephone for AC Wireline Conducted Emissions against the current USA and Canadian specifications for short-range device certification requirements. This addendum addresses the change in the specification for testing AC Wireline Conducted Emissions from 450 kHz - 30 MHz to 150 kHz – 30 MHz.

NetLink Wireless Telephone is designed and manufactured by SpectraLink Corporation, and used for NetLink Wireless Telephone System (WTS) also designed and manufactured by SpectraLink Corporation. The WTS is a fully featured, 802.11-b (DSSS) based wireless telephone system, providing both voice and data communications over a single integrated wireless network at in the 2.4GHz frequency band. NetLink WTS has two components, Wireless Telephones and Telephony Gateways.

NetLink Wireless Telephones operate as clients on the WLAN, alongside other mobile 802.11 devices. Wireless LAN fixed radios, called access points (APs), receive IP voice packets from Wireless Telephones and forward them to the NetLink Telephony Gateway over the Ethernet LAN.

The NetLink WTS simplifies LAN management and improves the cost-effectiveness of the network. With the NetLink Wireless Telephone, employees will have a phone whenever they need one, wherever they are in the facility. Wireless Telephones work just like a desktop telephone, with all the features and capabilities that employees desire, including: Display capabilities, Multiple line appearances, Host switch features, Message waiting indication, Messaging.

The following diagram identifies the NetLink system architecture and its position in a typical voice/data network.

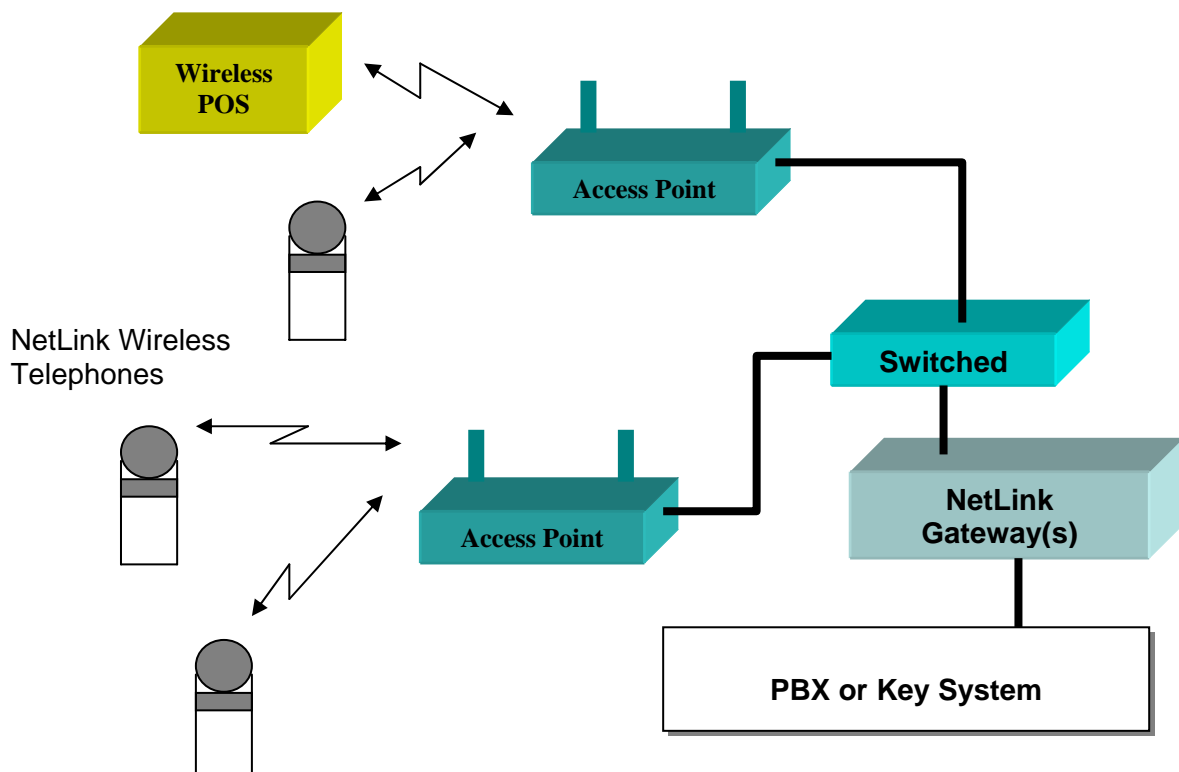



Title: Test of SpectraLink RNP2400 Telephone
To: FCC 47 CFR Part 15.247/IC RSS-210
Serial #: TUVR04 Addendum/REV A
Issue Date: 13th December '04
Page: 5 of 15

2 Technical Details

Purpose	To verify compliance of the RNP2400 Wireless Telephone to FCC and Industry Canada specifications for AC Wireline Conducted Emission measurements
Applicant / Client	SpectraLink Corporation 5755 Central Avenue Boulder, Colorado 80301, USA
Manufacturer	SpectraLink Corporation
Laboratory performing the tests	MiCOM Labs, Inc. 3922 Valley Avenue, Suite "B" Pleasanton, California 94566 USA
Test report reference number	TUVR04 Addendum/REV A
Date EUT received	11 th May '04
Standard applied	FCC 47 CFR Part 15.247/IC RSS-210
Dates of test (from - to)	11 th – 12 th May '04
No of Units:	One
Equipment Category:	802.11b Spread Spectrum Device
Trade Name:	SpectraLink
Type Number:	NetLink Wireless Telephone
Type of Equipment:	Standalone Telephone
Type Designation:	RNP2400
ITU Emission Code(s):	11M0D7E
Full Frequency Range:	2,400 – 2,483.5MHz
Frequency Channel Range:	2,412 – 2,462MHz (Channels 1 – 11)
Modulation:	DSSS
Microprocessor(s):	Texas Instruments 54xx
Operating Frequency (ies):	2,400 – 2,483.5MHz
Clock/Oscillator(s)	32.768KHz, 44MHz
Rated Input Voltage:	Nominal: +4.2Vdc Min - Max: +3.5V – 4.9Vdc
Aggregate Bit Rates:	1Mbit/s, 2Mbit/s, 5.5Mbit/s, 11Mbit/s
Antenna Gain:	0dBi
Nominal Output Power:	+20dBm
Temperature Range:	0 to +40°C
Primary Function Evaluation:	To initiate and receive telephone calls
Intended function in accordance with accompanying documentation	To initiate and receive telephone calls without perceptible degradation of voice quality or loss of correct keypad & display operation
Normal Test Modulation, Error Correction and Control Signals:	IEEE 802.11b

3 Test Summary

3.1 Test Configurations

Fundamental RF Frequency Generation

The manufacturer declared that the RF Frequency Generation section within the EUT (RNP2400) was identical to the Spectralink SNP2400, 2.4GHz 802.11b DSSS telephone,. Both products utilize the same part numbers for RF PCB board and components. Verification of the fundamental RF Frequency Generation PCB board and components utilized in telephone design are identified below;



RNP2400 RF Generation Board – Side A



RNP2400 RF Generation Board – Side B



SNP2400 RF Generation Board – Side A

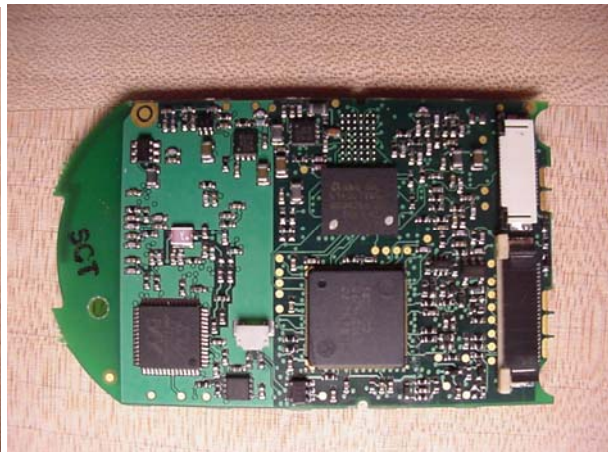

SNP2400 RF Generation Board – Side B

For the reason above measurements for conducted RF measurements were replicated from the SNP2400 telephone and reported within this document, see MiCOM Labs test report TUVR03a Rev A. Section 3.2, List of Measurements summarize all measurements extracted from this report. AC Wireline Conducted Emissions and General Field Strength measurements were targeted on this EUT.



Title: Test of SpectraLink RNP2400 Telephone
To: FCC 47 CFR Part 15.247/IC RSS-210
Serial #: TUVR04 Addendum/REV A
Issue Date: 13th December '04
Page: 7 of 15

3.2 List of Measurements

Section(s)	Test Items		Condition
	<i>Transmit mode (TX):</i>		
15.207 6.6	AC Wireline Conducted Emissions 150kHz–30MHz	Class B	Conducted

Note 1: These results were extracted from MiCOM Labs test report #: TUVR03a Rev A, see Section 3.1 'Test Configurations'



Title: Test of SpectraLink RNP2400 Telephone
To: FCC 47 CFR Part 15.247/IC RSS-210
Serial #: TUVR04 Addendum/REV A
Issue Date: 13th December '04
Page: 8 of 15

4 Summary Of Test Results

Test results reported in this document relate only to the items tested

Parameter	C	NC	NT	NA	Reference to remark
Transmitter characteristics					
AC Wireline Conducted Emissions (450KHz-30MHz)	X				

Note: C: The parameter is compliant with the requirements.
NC: The parameter is not compliant with the requirements.
NT: The parameter is not tested.
NA: The test of this parameter is not applicable.



5 Measurements, Examinations and Derived Results

5.1 General observations

Equipment Details - AC Wireline Conducted Emissions

Module:	Model Number:	Part Number:	Serial Number:
Netlink Telephone (integral antenna)	RNP2400	PTX150	640127998*
Class 2 AC/DC Wall Transformer (Input 120Vac 60Hz 18W)	D7-10-01	Not Available	Not Available
RNP2400 Desktop Charger	DCX100	84-0508-00 Rv A	None Available

*The models submitted for emission testing were manufactured products

Additional notes:

- 1. This report contains the test results only. Details of the test methods used have been recorded and are kept on file by the laboratory. Wherever possible, the test methods described in ETSI document EN 301 126 have been used.*
- 2. The measurement uncertainties stated are based on a standard uncertainty multiplied by a coverage factor $k = 2$, providing a level of confidence of approximately 95% in accordance with UKAS document M 3003.*

5.1.1 Emission characteristics

5.1.1.1 AC Wireline Conducted Emissions (150KHz – 30MHz)

Test Procedure

The conducted emissions are measured in a shielded room with a spectrum analyzer in peak hold in the first instance. Emissions closest to the limit are measured in the quasi-peak mode (QP) with the tuned receiver using a bandwidth of 9KHz. The emissions are maximized further by cable manipulation. The highest emissions relative to the limit are listed.

Test Measurement Setup

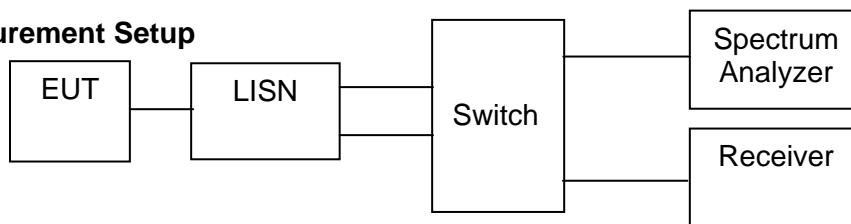

Measurement Results for AC Wireline Conducted Emissions (150KHz – 30MHz)

The EUT was found to comply to the limits of FCC Part 15, Subpart C and RSS-210 with a margin of 33.124dB. The six highest emissions relative to the limit are reported for two modes of operation. Spectrum analyzer pre-scan data plots are held in the laboratory for reference purposes.

Ambient conditions.

Temperature: 17 to 22 °C

Relative humidity: 34 to 65%

Pressure: 999 to 1012 mbar

EUT **SNP2400** LINE - LIVE

Frequency (MHz)	Peak Voltage (dB μ V)	Average Voltage (dB μ V)	Average Limit (dB μ V)	Margin (dB)
0.230	57.169	18.622	52.449	-33.827
0.246	56.781	18.321	51.891	-33.570
0.254	56.522	18.210	51.626	-33.416
0.286	55.031	17.515	50.639	-33.124
0.294	54.765	16.928	50.411	-33.483
0.306	54.227	16.530	50.078	-33.548



Title: Test of SpectraLink RNP2400 Telephone
To: FCC 47 CFR Part 15.247/IC RSS-210
Serial #: TUVR04 Addendum/REV A
Issue Date: 13th December '04
Page: 11 of 15

EUT SNP2400 LINE - NEUTRAL

Frequency (MHz)	Peak Voltage (dB μ V)	Average Voltage (dB μ V)	Average Limit (dB μ V)	Margin (dB)
0.250	55.707	18.199	51.757	-33.558
0.474	47.390	10.033	46.444	-36.411
0.510	45.722	9.530	46.000	-36.470
0.518	45.153	9.356	46.000	-36.644
0.562	42.088	8.204	46.000	-37.796
0.778	38.774	7.726	46.000	-38.274

Photographs of the test setup are provided in Section 5.1 'AC WIRELINE CONDUCTED EMISSION TEST SETUP'

Measurement Uncertainty Spectral Density

Measurement uncertainty (dB)	± 2.64
------------------------------	------------

Traceability

METHOD	TEST EQUIPMENT USED
Measurements were made per work instruction WI-EMC-01	0156, 0193, 0190, 15F50B001, 15F0B002

6 Photographs

6.1 AC Wireline Conducted Emission Test Setup

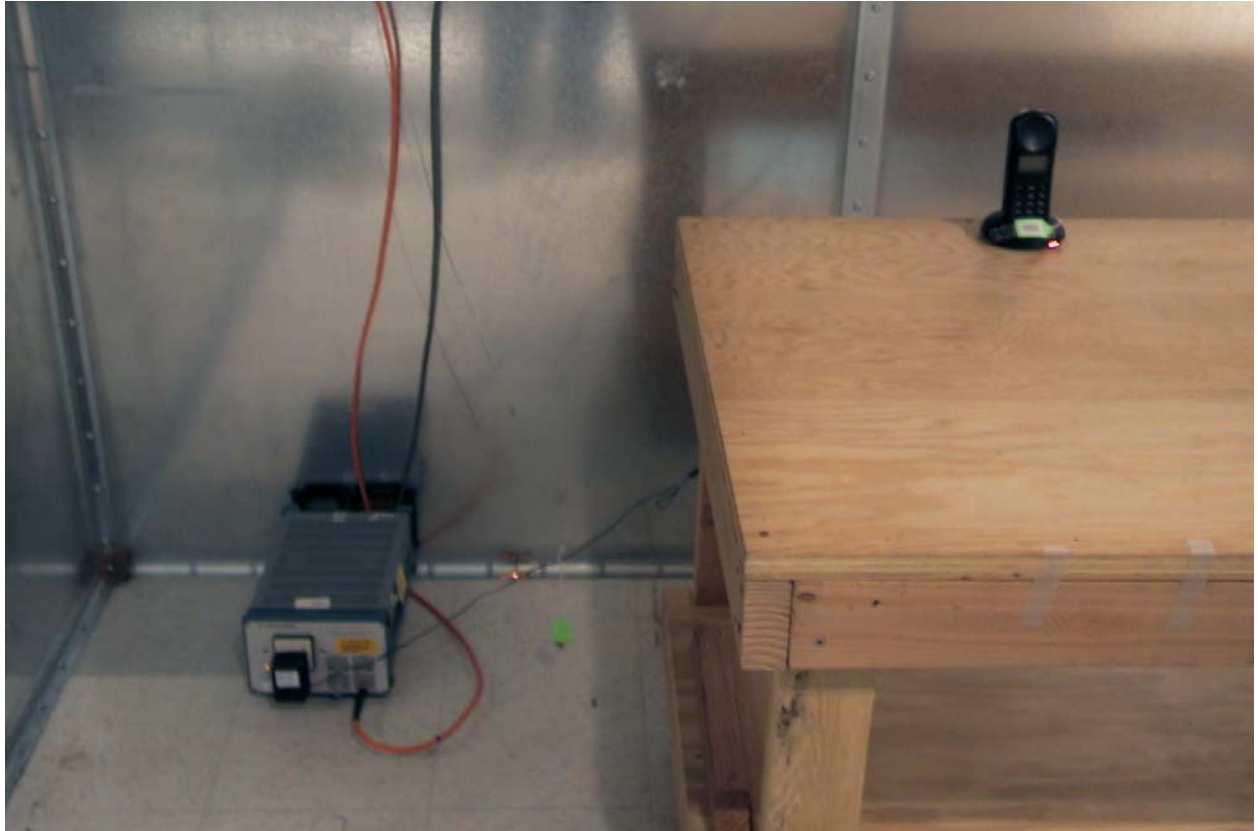



7 Graphical Results

Plot 1, AC Wireline Conducted Emissions Line N (Neutral)

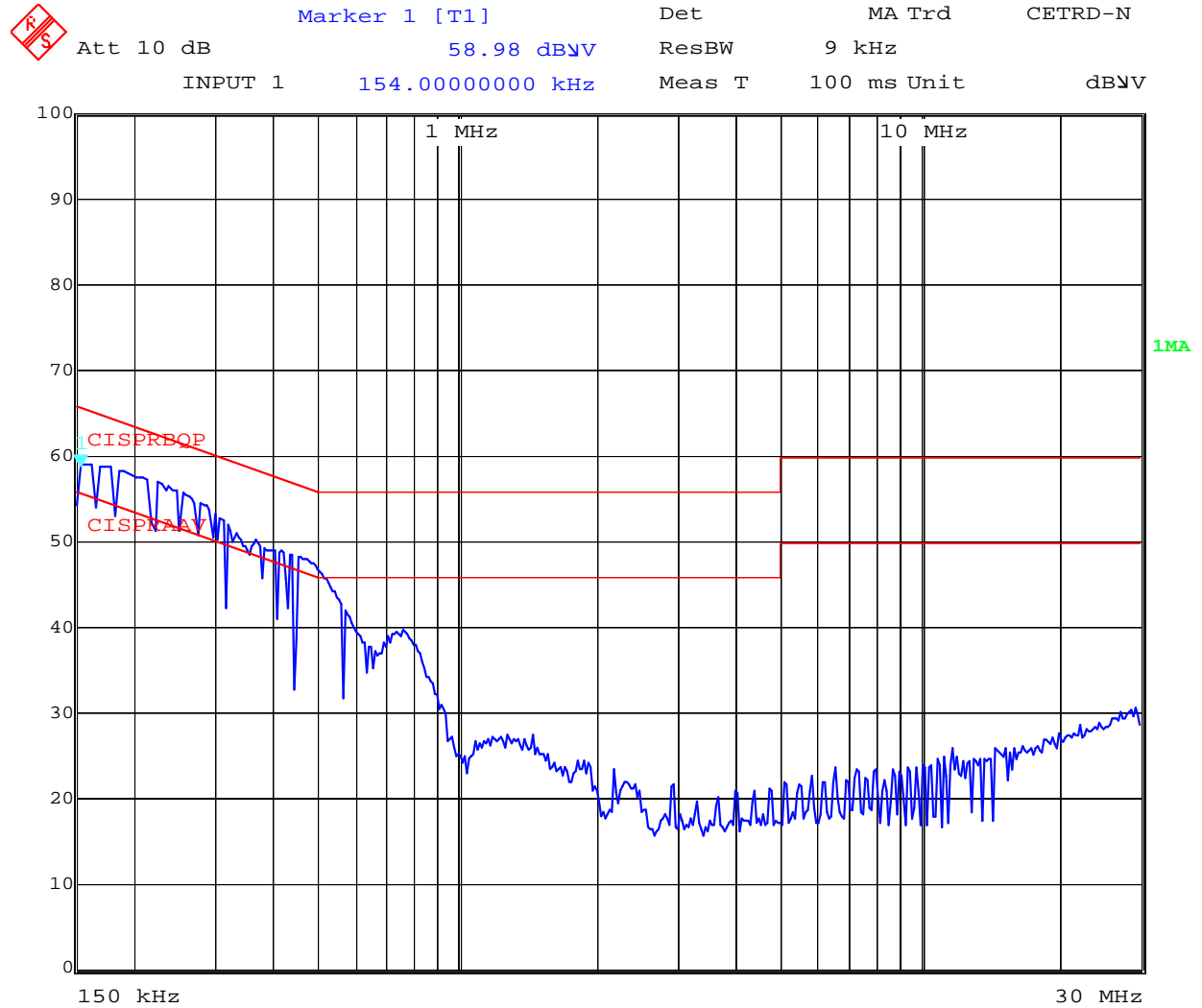

Date: 1.JAN.1997 00:09:29



Plot 2, AC Wireline Conducted Emissions Line L (Live)

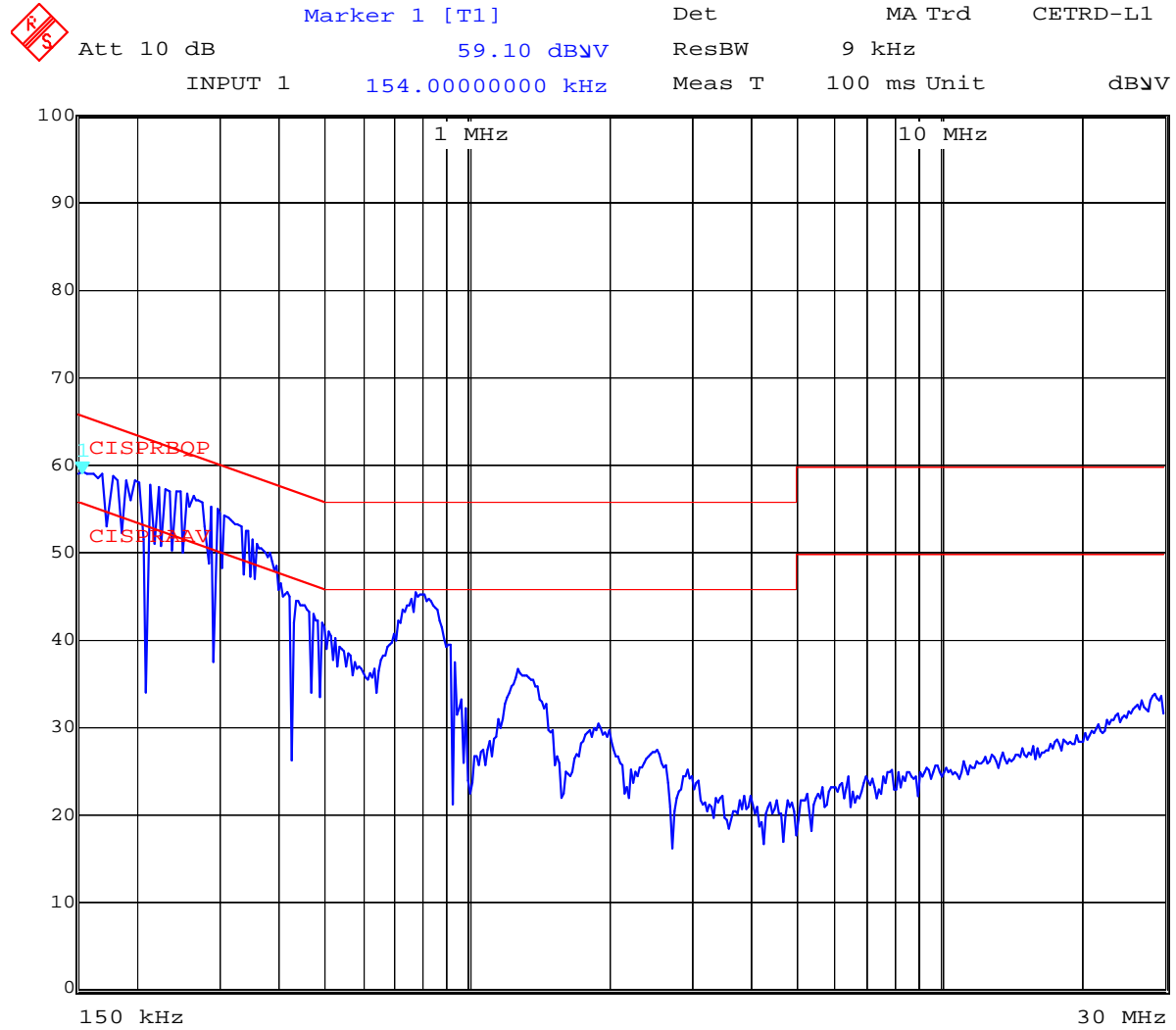

Date: 31.DEC.1996 23:44:04



Title: Test of SpectraLink RNP2400 Telephone
To: FCC 47 CFR Part 15.247/IC RSS-210
Serial #: TUVR04 Addendum/REV A
Issue Date: 13th December '04
Page: 15 of 15

8 Test Equipment

Asset #	Instrument	Manufacturer	Part #	Calibration Due Date	Serial #
0156	Barometer /Thermometer	Control Co.	4196	12 Aug '05	E2844
15F50B001	BNC Cable	Megaphase	Unknown	18 Jun '05	Unknown
15F50B002	BNC Cable	Megaphase	Unknown	18 Jun '05	Unknown
0193	EMI Receiver	Rhode & Schwartz	ESI 7	16 Mar '05	838496/007
0190	LISN	Rhode & Schwartz	ESH3Z5	3 Apr '05	836679/006



3922 Valley Avenue, Suite "B"
Pleasanton, CA 94566, USA
Tel: 1.925.462.0304
Fax: 1.925.462.0306
www.micomlabs.com