



**FCC PART 15C & RSS 210
TEST REPORT
No. I18N00940-NFC**

for

Spectralink Corp

GSM Quad-band/UMTS five-band/LTE/CA Mobile phone

9553

with

Hardware Version: PIO

Software Version: vF03

FCC ID: IYG95XX

IC: 2128B-95XX

Issued Date: 2018-09-10

Designation Number: CN1210

ISED Assigned Code: 23289

Note:

The test results in this test report relate only to the devices specified in this report. This report shall not be reproduced except in full without the written approval of SAICT.

Test Laboratory:

Shenzhen Academy of Information and Communications Technology

Building G, Shenzhen International Innovation Center, No.1006 Shennan Road, Futian District, Shenzhen, Guangdong, P. R. China 518026.

Tel: +86(0)755-33322000, Fax: +86(0)755-33322001

Email: yewu@caict.ac.cn, website: www.cszit.com

REPORT HISTORY

Report Number	Revision	Description	Issue Date
I18N00940-NFC	Rev.0	1st edition	2018-09-10

CONTENTS

1. TEST LABORATORY	4
1.1. TESTING LOCATION.....	4
1.2. TESTING ENVIRONMENT.....	4
1.3. PROJECT DATA.....	4
1.4. SIGNATURE.....	4
2. CLIENT INFORMATION	5
2.1. APPLICANT INFORMATION.....	5
2.2. MANUFACTURER INFORMATION.....	5
3. EQUIPMENT UNDER TEST (EUT) AND ANCILLARY EQUIPMENT (AE)	6
3.1. ABOUT EUT.....	6
3.2. INTERNAL IDENTIFICATION OF EUT USED DURING THE TEST.....	6
3.3. INTERNAL IDENTIFICATION OF AE.....	6
3.4. GENERAL DESCRIPTION.....	6
3.5. EUT SET-UPS.....	6
4. REFERENCE DOCUMENTS	7
4.1. DOCUMENTS SUPPLIED BY THE APPLICANT.....	7
4.2. REGULATIONS AND STANDARDS.....	7
5. LABORATORY ENVIRONMENT	8
6. TEST RESULTS	9
6.1. SUMMARY OF TEST RESULTS.....	9
6.2. TERMS USED IN THE SUMMARY OF TEST RESULTS.....	9
6.3. STATEMENTS.....	10
7. TEST EQUIPMENTS UTILIZED	11
ANNEX A: MEASUREMENT RESULTS	12
A.1. ELECTRIC FIELD STRENGTH OF FUNDAMENTAL AND OUTSIDE THE ALLOCATED BANDS.....	12
A.2. ELECTRIC FIELD RADIATED EMISSIONS (< 30MHz).....	14
A.3. ELECTRIC FIELD RADIATED EMISSIONS (\geq 30MHz).....	16
A.4. FREQUENCY TOLERANCE.....	18
A.5. 20dB BANDWIDTH.....	20
A.6. CONDUCTED EMISSION.....	22
A.7. OCCUPIED BANDWIDTH.....	26

1. Test Laboratory

1.1. Testing Location

Location: Shenzhen Academy of Information and Communications Technology
Address: Building G, Shenzhen International Innovation Center, No.1006
Shennan Road, Futian District, Shenzhen, Guangdong Province
Postal Code: 518026
Telephone: +86(0)755-33322000
Fax: +86(0)755-33322001

1.2. Testing Environment

Normal Temperature: 15-30°C
Relative Humidity: 35-60%

1.3. Project Data

Testing Start Date: 2018-07-01
Testing End Date: 2018-07-04

1.4. Signature

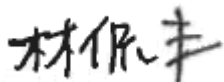

Lin Kanfeng
(Prepared this test report)



Tang Weisheng
(Reviewed this test report)



Zhang Bojun
(Approved this test report)

2. Client Information

2.1. Applicant Information

Company Name: Spectralink Corp
Address: 2560 55th Street Boulder, CO 80301 USA
Contact Person Andrew Duncan
E-Mail Andrew.duncan@spectralink.com
Telephone: +1 720-925-0480
Fax: /

2.2. Manufacturer Information

Company Name: Spectralink Corp
Address: 2560 55th Street Boulder, CO 80301 USA
Contact Person Andrew Duncan
E-Mail Andrew.duncan@spectralink.com
Telephone: +1 720-925-0480
Fax: /

3. Equipment Under Test (EUT) and Ancillary Equipment (AE)

3.1. About EUT

Description:	GSM Quad-band/UMTS five-band/LTE/CA Mobile phone
FCC ID	IYG95XX
IC number	2128B-95XX
With NFC Function:	Yes
Frequency:	13.56 MHz
Antenna:	Integrated
Operation Voltage:	3.5VDC to 4.4VDC (nominal: 3.7VDC)
Operation Temperature:	-20°C to +50°C

3.2. Internal Identification of EUT Used during the Test

Mobile phone identification

EUT ID*	IMEI	HW Version	SW Version	Receive Date
EUT1	/	PIO	vF03	2018-05-14

*EUT ID: is used to identify the test sample in the lab internally.

3.3. Internal Identification of AE

AE ID*	Description	SN
AE1	Switching Adapter	ASUC71w-050912300
AE2	Type A CARD	/

*AE ID: is used to identify the test sample in the lab internally.

3.4. General Description

The Equipment under Test (EUT) is a model of GSM Quad-band/UMTS five-band/LTE/CA Mobile phone with integrated antenna and battery.

Manuals and specifications of the EUT were provided to fulfil the test.

Samples undergoing test were selected by the client.

Manufacturer's declaration: NFC work does not depend on other access methods, such as WLAN, GPRS, etc.

3.5. EUT Set-ups

EUT Set-up No.	Combination of EUT and AE	Remarks
Set. NFC01	EUT1 + AE1 + AE2	/
Set. NFC02	EUT1	/
Set. NFC03	EUT1 + AE2	/

CE_test.apk is installed in the EUT which helps to control the NFC signal transmitting.

The Transmit State of NFC: the NFC function is on. The EUT will transmit the NFC data and command continuously during the test.

The Transmit State without modulation: The EUT will transmit the CW signal at the operating frequency.

4. Reference Documents

4.1. Documents Supplied by the Applicant

EUT feature information is supplied by the applicant or manufacturer, which is the basis of testing.

4.2. Regulations and Standards

The following documents listed in this section are referred for testing.

Reference	Title	Version
CFR 47 Part 2	Part 2 — Frequency Allocations and Radio Treaty Matters; General Rules and Regulations.	2014
CFR 47 Part 15	Part 15 - Radio Frequency Devices. Subpart C - Intentional Radiators. § 15.35 Measurement detector functions and bandwidths. § 15.207 Conducted limits. § 15.209 Radiated emission limits, general requirements. § 15.215 Additional provisions to the general radiated emission limitations. § 15.225 Operation within the band 13.110–14.010 MHz.	2015
ANSI C63.4	American National Standard for Methods of Measurement of Radio-Noise Emissions from Low-Voltage Electrical and Electronic Equipment in the Range of 9 kHz to 40 GHz.	2014
RSS-210	License-exempt Radio Apparatus (All Frequency Bands): Category I Equipment Annex 2 - Devices Operating in Frequency Bands for Any Application	Issue 9 2016
RSS-Gen	Spectrum Management and Telecommunications Radio Standards Specification General Requirements for Compliance of Radio Apparatus	Issue 5 April, 2018

5. Laboratory Environment

Semi-anechoic chamber did not exceed following limits along the EMC testing

Temperature	Min. = 15 °C, Max. = 30 °C
Relative humidity	Min. = 35 %, Max. = 60 %
Shielding effectiveness	0.014MHz - 1MHz, >60dB; 1MHz - 1000MHz, >90dB.
Electrical insulation	> 2 MΩ
Ground system resistance	< 4Ω
Normalised site attenuation (NSA)	< ±4dB, 3m/10m distance, from 30 to 1000 MHz
Uniformity of field strength	Between 0 and 6 dB, from 80 to 3000 MHz

Shielded room did not exceed following limits along the EMC testing

Temperature	Min. = 15 °C, Max. = 30 °C
Relative humidity	Min. = 35 %, Max. = 60 %
Shielding effectiveness	0.014MHz - 1MHz, >60dB; 1MHz - 1000MHz, >90dB.
Electrical insulation	> 2 MΩ
Ground system resistance	< 4 Ω

Fully-anechoic chamber did not exceed following limits along the EMC testing

Temperature	Min. = 15 °C, Max. = 30 °C
Relative humidity	Min. = 35 %, Max. = 60 %
Shielding effectiveness	0.014MHz - 1MHz, >60dB; 1MHz - 1000MHz, >90dB.
Electrical insulation	> 2 MΩ
Ground system resistance	< 4Ω
Voltage Standing Wave Ratio (VSWR)	≤6dB, from 1 to 18 GHz, 3m distance

6. Test Results

6.1. Summary of Test Results

No	Test Cases	Clause in Regulation	Section in This Report	Verdict
1	Electric Field Strength of Fundamental Emissions	CFR 47 § 15.225(a) RSS-210 Issue9 A2.6	A.1	P
2	Electric Field Strength of Outside the Allocated Bands	CFR 47 § 15.225(b) CFR 47 § 15.225(c) RSS-210 Issue9 A2.6		P
3	Electric Field Radiated Emissions	CFR 47 § 15.209 CFR 47 § 15.225(d) RSS-210 Issue9 A2.6	A.2	P
			A.3	P
4	Frequency Tolerance	CFR 47 § 15.225(e) RSS-210 Issue9 A2.6	A.4	P
5	20dB Bandwidth	CFR 47 § 15.215(c)	A.5	P
6	Conducted Emissions	CFR 47 § 15.207 RSS-Gen Issue4 8.8	A.6	P
7	Occupied Bandwidth	RSS-Gen Issue4 6.6	A.7	P

The measurement is carried out according to ANSI C63.4. See **ANNEX A** for details.

Test Conditions:

For this report, all the test cases listed above were tested under normal Temperature, Voltage, Humidity, and Air Pressure. The specific conditions are as following:

Temperature	T min	-20 °C
	T nom	25 °C
	T max	50 °C
Voltage	V min	3.5 V
	V nom	3.7 V
	V max	4.4 V

6.2. Terms Used in the Summary of Test Results

Terms Used in Condition Column:

T nom	Normal Temperature
T min	Low Temperature
T max	High Temperature
V nom	Normal Voltage
V min	Low Voltage
V max	High voltage
H nom	Norm Humidity
A nom	Norm Air Pressure

Terms Used in Verdict Column:

P	Pass, The EUT complies with the essential requirements in the standard.
NP	Not Perform, The test was not performed by SAICT
NA	Not Applicable, The test was not applicable
F	Fail, The EUT does not comply with the essential requirements in the standard

Abbreviations:

AC	Alternating Current
AFH	Adaptive Frequency Hopping
BW	Band Width
E.I.R.P.	equivalent isotropic radiated power
ISM	Industrial, Scientific and Medical
RF	Radio Frequency
Tx	Transmitter

6.3. Statements

The test cases listed in Section 6.1 of this report for the EUT specified in Section 3 were performed by SAICT according to the reference documents in Section 4.

The EUT meets all applicable requirements of the regulations and standards in Section 4.2.

This report only deals with the NFC function among the features described in section 3.

7. Test Equipments Utilized

Conducted test system

NO.	EQUIPMENT	MODEL	SERIES NUMBER	MANUFACTURE	CAL DUE DATE
1.	Vector Signal Analyzer	FSV40	100903	Rohde & Schwarz	2019-01-17
2.	DC Power Supply	NGSM 32/10	5425	Rohde & Schwarz	2018-11-11

Climate chamber

NO.	EQUIPMENT	MODEL	SERIES NUMBER	MANUFACTURE	CAL DUE DATE
1.	Climate chamber	SU-242	93008165	ESPEC	2019-04-05

Radiated emission test system

NO.	EQUIPMENT	MODEL	SERIES NUMBER	MANUFACTURE	CAL DUE DATE
1.	Chamber	FACT3-2.0	1285	ETS-Lindgren	2019-11-27
2.	Test Receiver	ESCI	101676	Rohde & Schwarz	2018-11-29
3.	Loop Antenna	HLA6120	35779	TESEQ	2019-05-02
4.	BiLog Antenna	VULB9163	9163 329	Schwarzbeck	2020-02-27
5.	LISN	ESH2-Z5	100196	Rohde & Schwarz	2019-01-04

ANNEX A: MEASUREMENT RESULTS

A.1. Electric Field Strength of Fundamental and Outside the Allocated bands

A.1.1. Reference

See Clause 13.5, Clause 13.4, Clause 8, and Annex E of ANSI C63.4-2014 specifically

See Clause 4, Clause 5, and Clause 6 of ANSI C63.4-2014 generally

See CFR 47 § 15.225(a)

See RSS-210 Issue9 A2.6

A.1.2. Measurement Methods

The transmitter carrier output levels (E-Field) from the EUT are measured in a semi-anechoic chamber. The EUT is placed on a non-conductive stand of 80cm high, and at a measurement distance of 3m from the receiving antenna. The center of the receiving loop antenna is 1.0 meter above the ground. The E-field is measured with a shielded loop antenna connected to a measurement receiver. Detected E-field was maximized by rotating the EUT through 360° and adjusting the receiving antenna polarizations. The maximization processes were repeated with the EUT positioned respectively in its three orthogonal axes. The measurements were performed with the peak detector and if required, the quasi-peak detector.

The measurement bandwidth is:

Frequency of Emission (MHz)	RBW/VBW
12.56-14.56	10/30 kHz

The E-field measured at 3m is calculated as:

$$E\text{-field (dB}\mu\text{V/m)} = Rx \text{ (dB}\mu\text{V)} + \text{Cable Loss (dB)} + AF@3m \text{ (dB/m)}$$

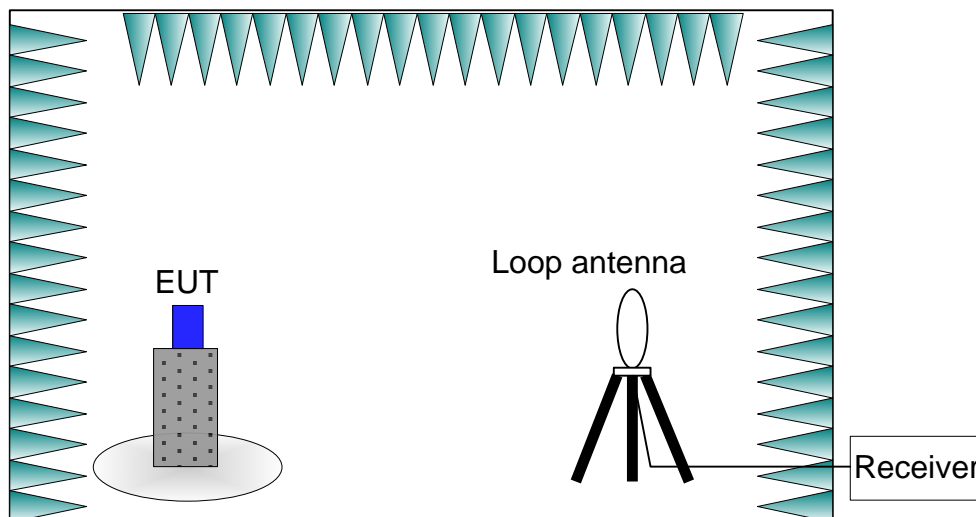

A.1.3. EUT Operating Mode and Test Conditions

The measurement of EUT is carried out under the transmit state of NFC (See 3.5).

The EUT is powered by a travel adapter.

During the measurements, the ambient temperature of the electromagnetic anechoic chamber is

in the range of 15 ~ 25°C.

A.1.4. Limits

Frequency Range (MHz)	E-field Strength Limit @ 30 m (μV/m)	E-field Strength Limit @ 3 m (dBμV/m)
13.560 ± 0.007	+15,848	124
13.410 to 13.553 13.567 to 13.710	+334	90
13.110 to 13.410 13.710 to 14.010	+106	81

Note: Where the limits have been defined at one distance, and a signal level measured at another, the limits have been extrapolated using the following formula:

$$\text{Extrapolation(dB)} = 40\log_{10}(\text{Measurement Distance}/\text{Specification Distance})$$

A.1.5. Measurement Results

Measurement results of normal conditions see Figure A-1 for different set-ups of EUT. The result displayed take into account applicable antenna factors and cable losses.

Conclusions: Set. NFC01, **PASS**.

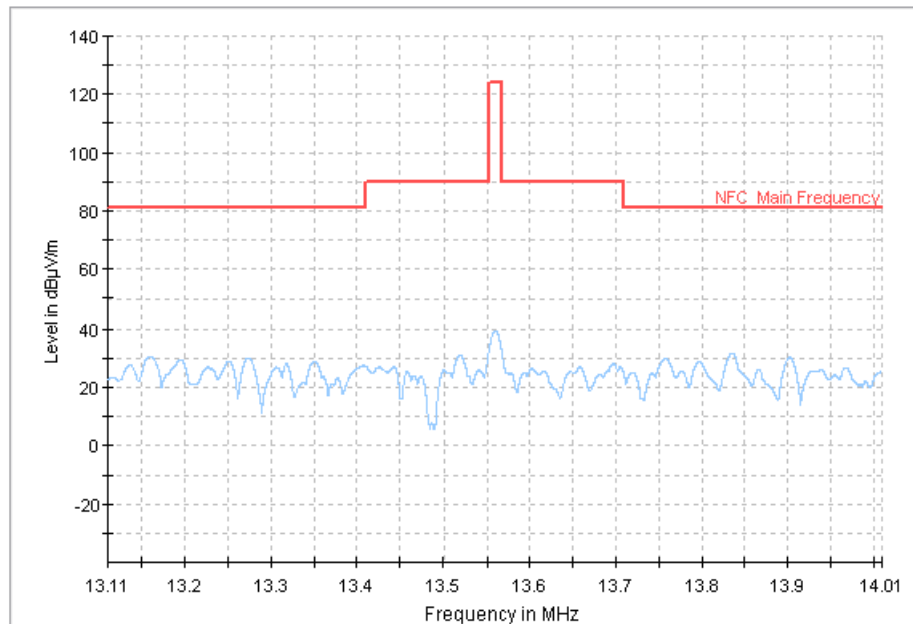

Figure A-1 Test result of EUT1 at test Set. NFC01

A.1.6. Measurement Uncertainty

Measurement uncertainty: $U = 4.0 \text{ dB}$, $k=2$.

A.2. Electric Field Radiated Emissions (< 30MHz)

A.2.1. Reference

See Clause 13.4, Clause 8 and Annex E of ANSI C63.4-2014 specifically

See Clause 4, Clause 5, and Clause 6 of ANSI C63.4-2014 generally

See CFR 47 § 15.225(b)

See CFR 47 § 15.225(c)

See RSS-210 Issue9 A2.6

A.2.2. Measurement Methods

The transmitter carrier output levels (E-Field) from the EUT are measured in a semi-anechoic chamber. The EUT is placed on a non-conductive stand of 80cm high, and at a measurement distance of 3m from the receiving antenna. The center of the receiving loop antenna is 1.0 meter above the ground. The E-field is measured with a shielded loop antenna connected to a measurement receiver. Detected E-field was maximized by rotating the EUT through 360° and adjusting the receiving antenna polarizations. The maximization processes were repeated with the EUT positioned respectively in its three orthogonal axes. The measurements were performed with the peak detector and if required, the quasi-peak detector.

The measurement bandwidth is:

Frequency of Emission (MHz)	RBW/VBW
0.009-0.15	100/300 Hz
0.15-30	10/30 kHz

The E-field measured at 3m is calculated as:

$$\text{E-field (dB}\mu\text{V/m)} = \text{Rx (dB}\mu\text{V)} + \text{Cable Loss (dB)} + \text{AF@3m (dB/m)}$$

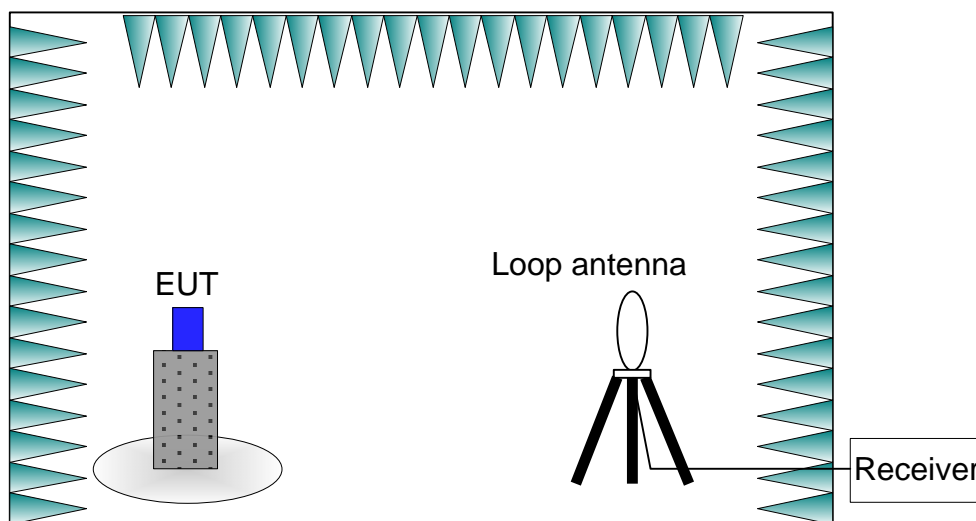

A.2.3. EUT Operating Mode and Test Conditions

The measurement of EUT is carried out under the transmit state of NFC (See 3.5).

The EUT is powered by a travel adapter.

During the measurements, the ambient temperature of the electromagnetic anechoic chamber is in the range of 15 ~ 25°C.

A.2.4. Limits

Frequency Range (MHz)	E-field Strength Limit @ 30m (mV/m)	E-field Strength Limit @ 3m (dBµV/m)
0.009-0.490	2400/F(kHz)	129-94
0.490-1.705	24000/F(kHz)	74-63
1.705-30	30	70

Note: Where the limits have been defined at one distance, and a signal level measured at another, the limits have been extrapolated using the following formula:
 Extrapolation(dB) = 40log₁₀(Measurement Distance/Specification Distance)

A.2.5. Measurement Results

Measurement results of normal conditions see Figure A-2 for different set-ups of EUT. The result displayed take into account applicable antenna factors and cable losses.

Conclusions: Set. NFC01, **PASS**.

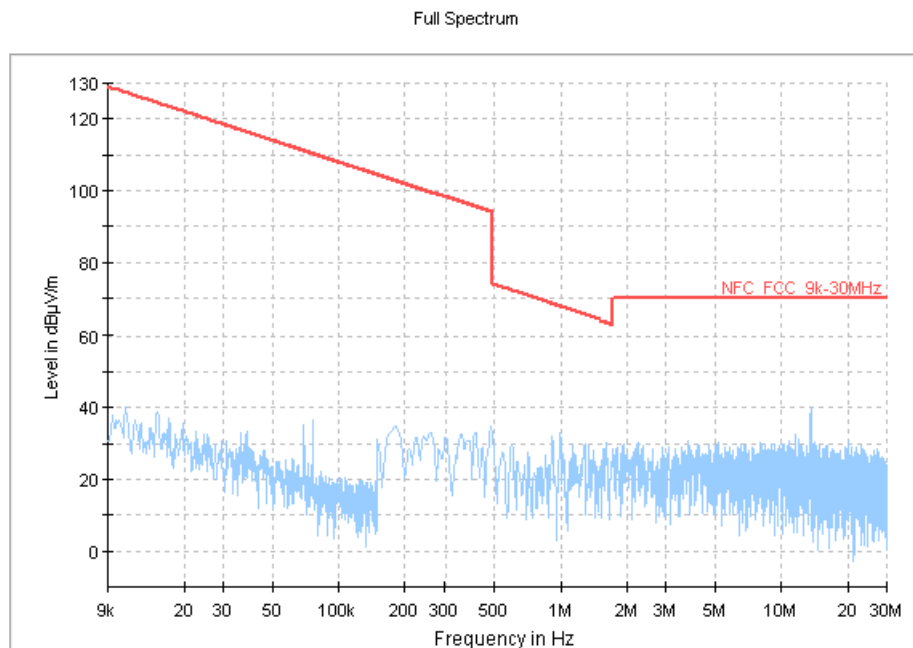

Figure A-2 Test result of EUT1 at test Set. NFC01

A.2.6. Measurement Uncertainty

Measurement uncertainty: $U = 4.0$ dB, $k=2$.

A.3. Electric Field Radiated Emissions ($\geq 30\text{MHz}$)

A.3.1. Reference

See Clause 13.4, Clause 8, and Annex E of ANSI C63.4-2014 specifically

See Clause 4, Clause 5, and Clause 6 of ANSI C63.4-2014 generally

See CFR 47 § 15.209

See CFR 47 § 15.225(d)

See RSS-210 Issue9 A2.6

A.3.2. Measurement Methods

The electric field radiated emissions from the EUT are measured in a semi-anechoic chamber. The EUT is placed on a non-conductive stand of 80cm high, and at a measurement distance of 10m from the receiving antenna. The receiving antennas connected to a measurement receiver comply with Clause 15 of ANSI C63.2-1996 and Clause 4.1.5 of ANSI C63.4-2014. In order to search for maximum field strength emitted from the EUT, the receiving antenna can be moved between the height of 1.0 m to 4.0 m. Detected E-field was maximized at each frequency by rotating the EUT through 360° and adjusting the receiving antenna positions for both vertical and horizontal antenna polarizations. The maximization processes were repeated with the EUT positioned respectively in its three orthogonal axes. The measurements were performed with the peak detector and if required, the quasi-peak detector.

The measurement bandwidth is:

Frequency of Emission (MHz)	RBW/VBW
30-1000	120kHz

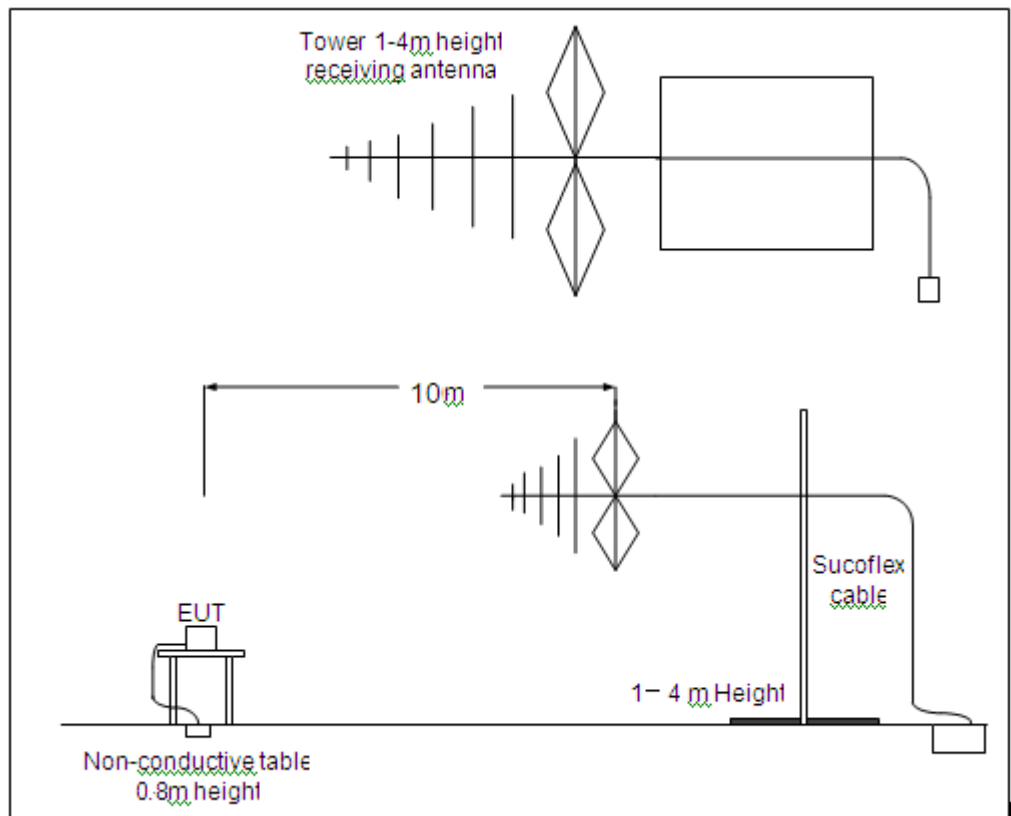

A.3.3. EUT Operating Mode and Test Conditions

The measurement of EUT is carried out under the transmit state of NFC (See 3.5).

EUT had been connected to a travel adapter.

During the measurements, the ambient temperature of the electromagnetic anechoic chamber is in the range of 15 ~ 25°C.

A.3.4. Limits

Frequency Range (MHz)	E-field Strength Limit @ 3m (mV/m)	E-field Strength Limit @ 3m (dB μ V/m)	E-field Strength Limit @ 10m (dB μ V/m)
30-88	100	40	30
88-216	150	43.5	33.5
216-960	200	46	36
960-1000	500	54	44

A.3.5. Measurement Results

Measurement results of normal conditions see Figure A-3 for different set-ups of EUT. The result displayed take into account applicable antenna factors and cable losses.

Conclusions: Set. NFC01, **PASS**.

A.3.6. Measurement Uncertainty

Measurement uncertainty: $U = 3.9$ dB, $k=2$

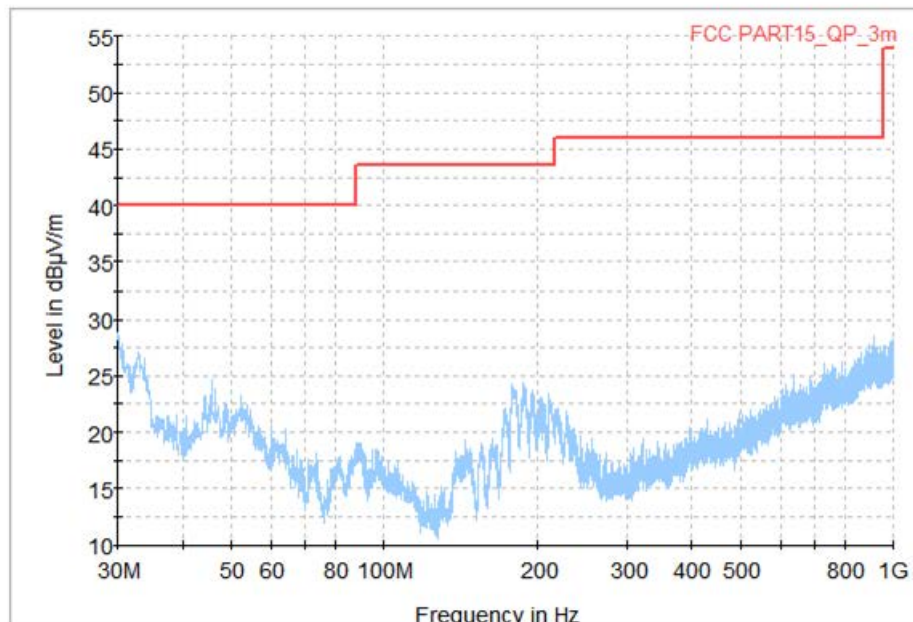

Figure A-3 Test result of EUT1 at test Set. NFC01

A.4. Frequency Tolerance

A.4.1. Reference

See Clause 13.6 of ANSI C63.4-2014 specifically

See Clause 4, Clause 5, and Clause 6 of ANSI C63.4-2014 generally

See RSS-210 Issue9 A2.6

See CFR 47 § 15.225(e)

See RSS-210 Issue9 A2.6

A.4.2. Measurement Methods

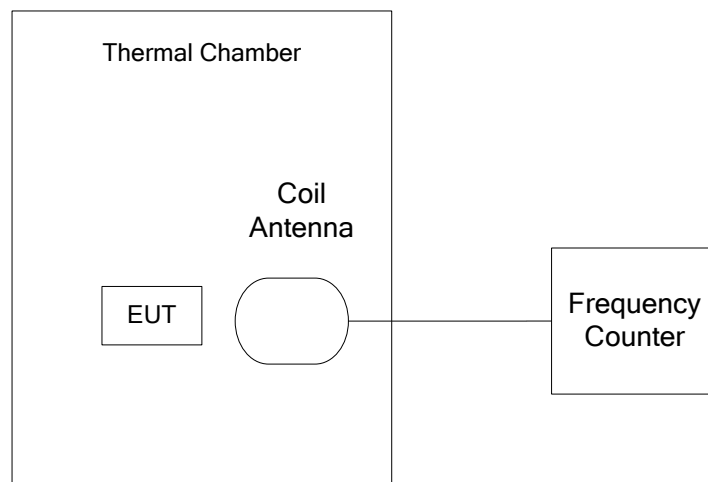

The transmitter output signal was picked up by coil antenna connected to the frequency counter.

The center frequency was measured with 30Hz RBW and 1kHz span.

During the test, the EUT was placed in a thermal chamber until thermal balance and lasting appropriate time.

A.4.3. EUT Operating Mode and Test Conditions

The measurement of EUT is carried out under the transmit state of without modulation (See 3.5).

EUT had been not connected to a travel adapter.

Operation Temperature: T min, T nom, and T max with V nom.

Operation Voltage: V min and V max with T nom.

A.4.4. Test Layouts

See A.4.2.

A.4.5. Limits

The frequency tolerance of the carrier signal shall be maintained within +/- 0.01% of the operating frequency.

A.4.6. Measurement Results

Measurement results see Table A-1 for different test conditions.

Conclusions: Set. NFC02, **PASS**.

Table A-1: Frequency Stability VS Temperature and Voltage

Temperature	Voltage	Frequency Error (MHz)			
		Startup	2 Min Later	5 Min Later	10 Min Later
T min	V nom	13.559710	13.559710	13.559710	13.559710
T max	V nom	13.559716	13.559716	13.559716	13.559716
T nom	V nom	13.559711	13.559711	13.559711	13.559711
T nom	V min	13.559711	13.559711	13.559711	13.559711
T nom	V max	13.559711	13.559711	13.559711	13.559711

Temperature	Voltage	Frequency Error (%)			
		Startup	2 Min Later	5 Min Later	10 Min Later
T min	V nom	0.002	0.002	0.002	0.002
T max	V nom	0.002	0.002	0.002	0.002
T nom	V nom	0.002	0.002	0.002	0.002
T nom	V min	0.002	0.002	0.002	0.002
T nom	V max	0.002	0.002	0.002	0.002

A.4.7. Measurement Uncertainty

Measurement uncertainty: $U = 77 \text{ Hz}$, $k=2$

A.5. 20dB Bandwidth

A.5.1. Reference

See Clause 13.7 of ANSI C63.4-2014 specifically

See Clause 4, Clause 5, and Clause 6 of ANSI C63.4-2014 generally

See CFR 47 § 15.215(c)

A.5.2. Measurement Methods

The transmitter output signal was picked up by coil antenna to the spectrum analyzer.

The transmitter output signal was picked up by coil antenna connected to the spectrum analyzer.

The bandwidth of the center frequency was measured with 140Hz RBW, 420Hz VBW and 14kHz span.

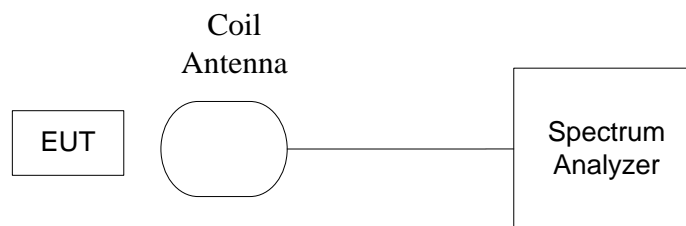

A.5.3. EUT Operating Mode and Test Conditions

The measurement of EUT is carried out under the transmit state of NFC and without modulation (See 3.5).

EUT had been not connected to a travel adapter.

During the measurements, the ambient temperature is in the range of 15 ~ 25°C.

A.5.4. Test Layouts

See A.5.2.

A.5.5. Limits

The 20dB bandwidth shall be less than 80% of the permitted frequency band. For 13.56 MHz NFC, the permitted frequency band is 14 kHz, so the limit is 11.2 kHz.

A.5.6. Measurement Results

Measurement results see Figure A-4.

Conclusions: Set. NFC03, **PASS**.

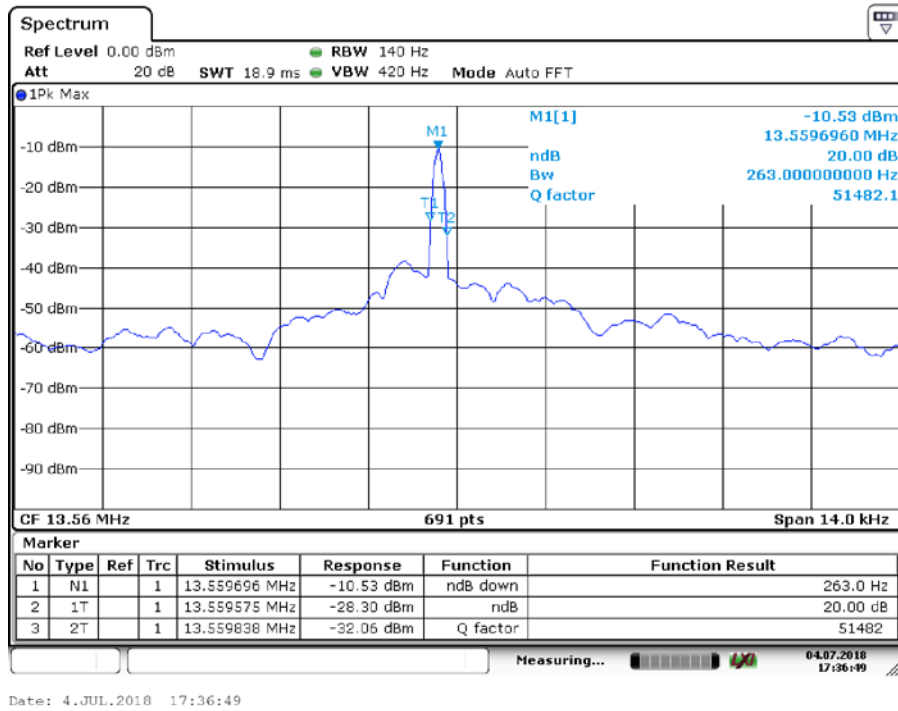

Figure A-4 Test result of EUT1 at test set. NFC03

A.5.7. Measurement Uncertainty

Measurement uncertainty: $U = 77$ Hz, $k=2$

A.6. Conducted emission

A.6.1. Reference

See Clause 13.3 and Clause 7 of ANSI C63.4-2014 specifically

See Clause 4, Clause 5, and Clause 6 of ANSI C63.4-2014 generally

See CFR 47 § 15.207

See RSS-Gen Issue4 8.8

A.6.2. Measurement Methods

The conducted emissions from the AC port of the EUT are measured in a shielding room. The EUT is connected to a Line Impedance Stabilization Network (LISN). An overview sweep with peak detection was performed. The measurements were performed with a quasi-peak detector and if required, an average detector.

The conducted emission measurements were made with the following detector of the test receiver: Quasi-Peak / Average Detector.

The measurement bandwidth is:

Frequency of Emission (MHz)	RBW/VBW
0.15-30	9kHz

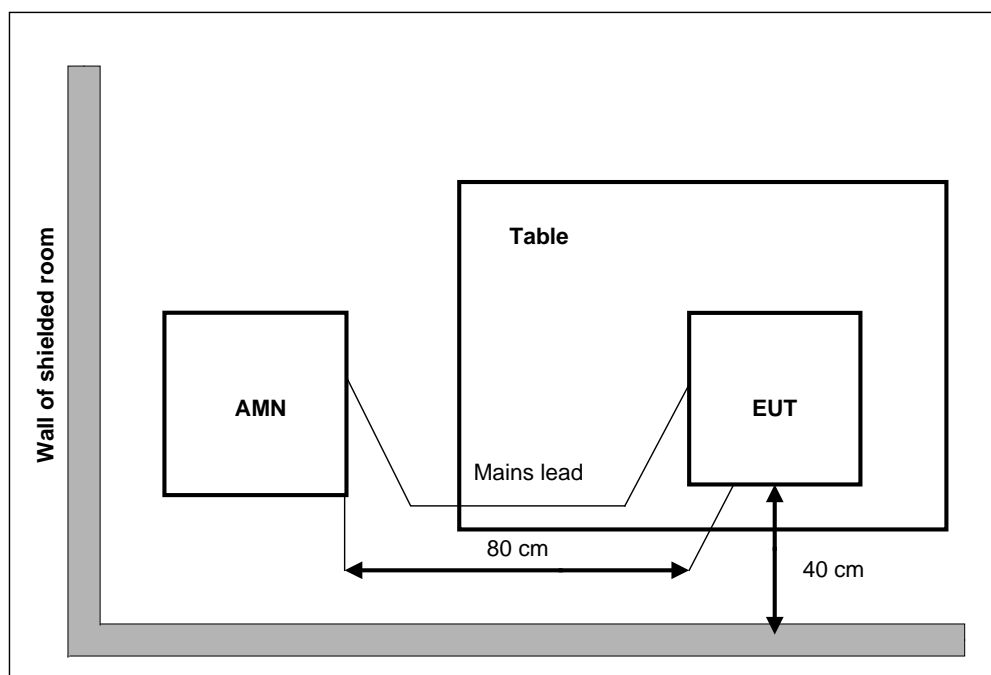

A.6.3. EUT Operating Mode and Test Conditions

The measurement of EUT is carried out under the transmit state of NFC (See 3.5).

The EUT is powered by a travel adapter.

During the measurements, the ambient temperature is in the range of 15 ~ 25°C.

A.6.4. Limits

Frequency range (MHz)	Quasi-peak Limit (dB μ V)	Average Limit (dB μ V)
0.15 to 0.5	66 to 56	56 to 46
0.5 to 5	56	46
5 to 30	60	50

A.6.5. Measurement Results

Measurement results see Figure A-5, Figure A-6.

Conclusions: Set. NFC01, **PASS**.

Note: The measurement result at 13.56MHz is the fundamental emission of NFC signal.

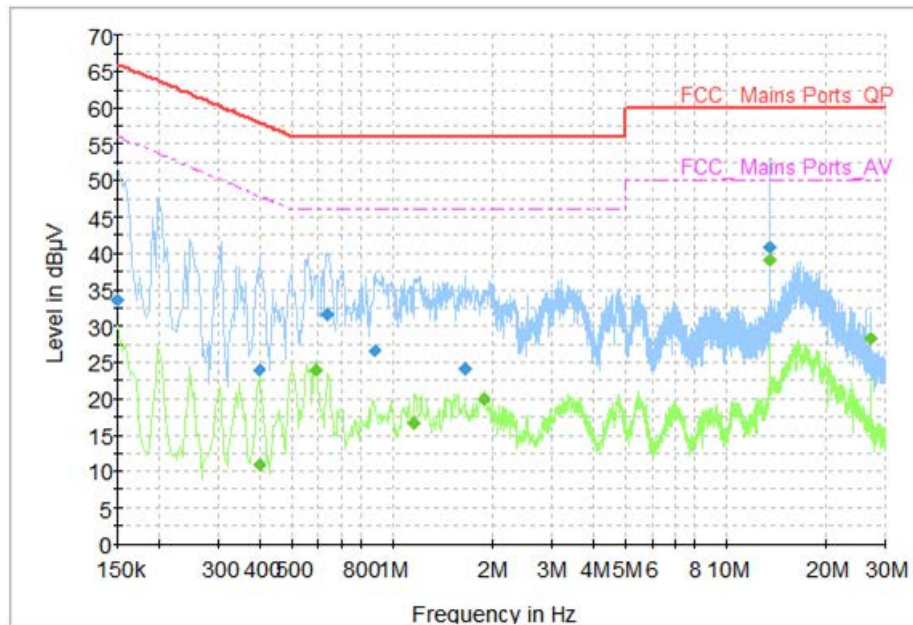

Figure A-5 Test result of EUT1 at test set. NFC01(120V)

Final Result 1

Frequency(MHz)	QuasiPeak(dBµV)	Limit(dBµV)	Margin(dB)	Line	Filter	Corr.(dB)
0.150000	33.57	66.00	32.43	N	ON	9.6
0.398000	23.97	57.90	33.92	N	ON	9.6
0.634000	31.62	56.00	24.38	N	ON	9.7
0.882000	26.54	56.00	29.46	N	ON	9.7
1.650000	24.08	56.00	31.92	N	ON	9.7
13.558000	40.77	60.00	19.23	N	ON	9.9

Final Result 2

Frequency(MHz)	Average(dBµV)	Limit(dBµV)	Margin(dB)	Line	Filter	Corr.(dB)
0.398000	10.92	47.90	36.98	N	ON	9.6
0.586000	23.98	46.00	22.02	L1	ON	9.7
1.162000	16.63	46.00	29.37	L1	ON	9.7
1.866000	19.94	46.00	26.06	L1	ON	9.7
13.558000	39.22	50.00	10.78	N	ON	9.9
27.118000	28.21	50.00	21.79	N	ON	10.2

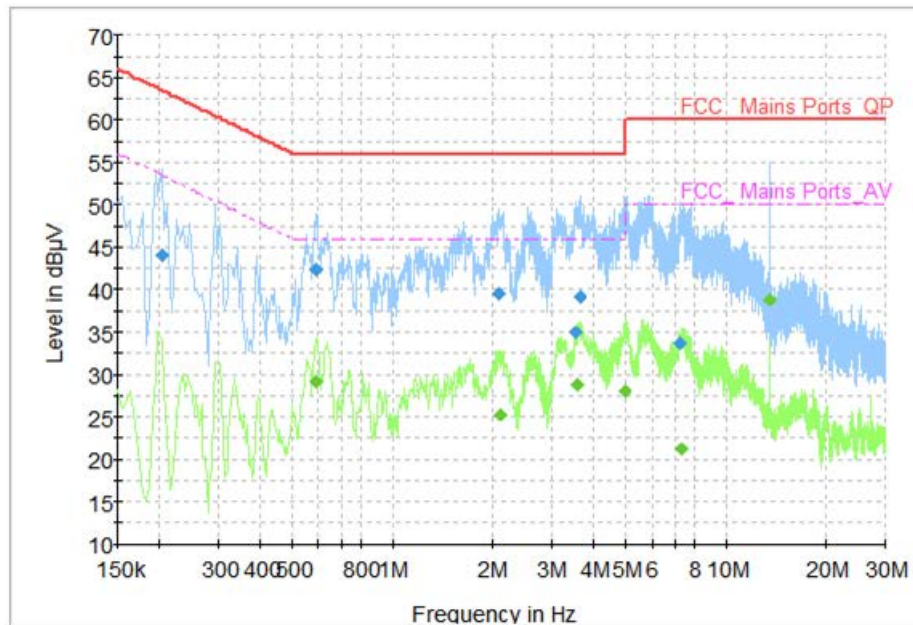

Figure A-6 Test result of EUT1 at test set. NFC01(240V)

Final Result 1

Frequency(MHz)	QuasiPeak(dBµV)	Limit(dBµV)	Margin(dB)	Line	Filter	Corr.(dB)
0.202000	43.97	63.53	19.56	L1	ON	9.7
0.586000	42.41	56.00	13.59	N	ON	9.7
2.090000	39.45	56.00	16.55	N	ON	9.7
3.554000	34.89	56.00	21.11	N	ON	9.7
3.654000	39.12	56.00	16.88	N	ON	9.7
7.250000	33.68	60.00	26.32	N	ON	9.8

Final Result 2

Frequency(MHz)	Average(dBµV)	Limit(dBµV)	Margin(dB)	Line	Filter	Corr.(dB)
0.586000	29.13	46.00	16.87	N	ON	9.7
2.102000	25.24	46.00	20.76	N	ON	9.7
3.586000	28.73	46.00	17.27	N	ON	9.7
4.974000	27.95	46.00	18.05	N	ON	9.7
7.342000	21.13	50.00	28.87	N	ON	9.8
13.558000	38.87	50.00	11.13	N	ON	9.9

A.6.6. Measurement Uncertainty

Measurement uncertainty: $U = 3.2 \text{ dB}$, $k=2$

A.7. Occupied Bandwidth

A.7.1. Reference

See Clause 13.7 of ANSI C63.4-2014 specifically

See Clause 4, Clause 5, and Clause 6 of ANSI C63.4-2014 generally

See RSS-Gen Issue4 6.6

A.7.2. Measurement Methods

The transmitter output signal was picked up by coil antenna to the spectrum analyzer.

The transmitter output signal was picked up by coil antenna connected to the spectrum analyzer.

The bandwidth of the center frequency was measured with 140Hz RBW, 420Hz VBW and 14kHz span.

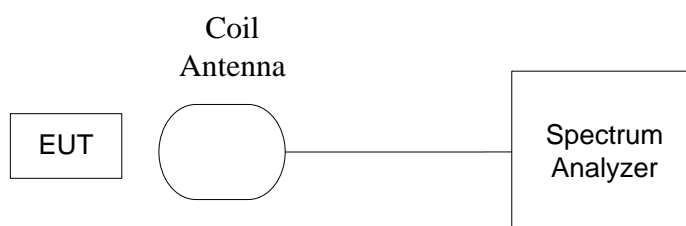

A.7.3. EUT Operating Mode and Test Conditions

The measurement of EUT is carried out under the transmit state of NFC and without modulation (See 3.5).

EUT had been not connected to a travel adapter.

During the measurements, the ambient temperature is in the range of 15 ~ 25°C.

A.7.4. Test Layouts

See A.7.2.

A.7.5. Limits

When the occupied bandwidth limit is not stated in the applicable RSS or reference measurement method, the transmitted signal bandwidth shall be reported as the 99% emission bandwidth, as calculated or measured.

A.7.6. Measurement Results

Measurement results see Figure A-7.

Conclusions: Set. NFC03, **PASS**.

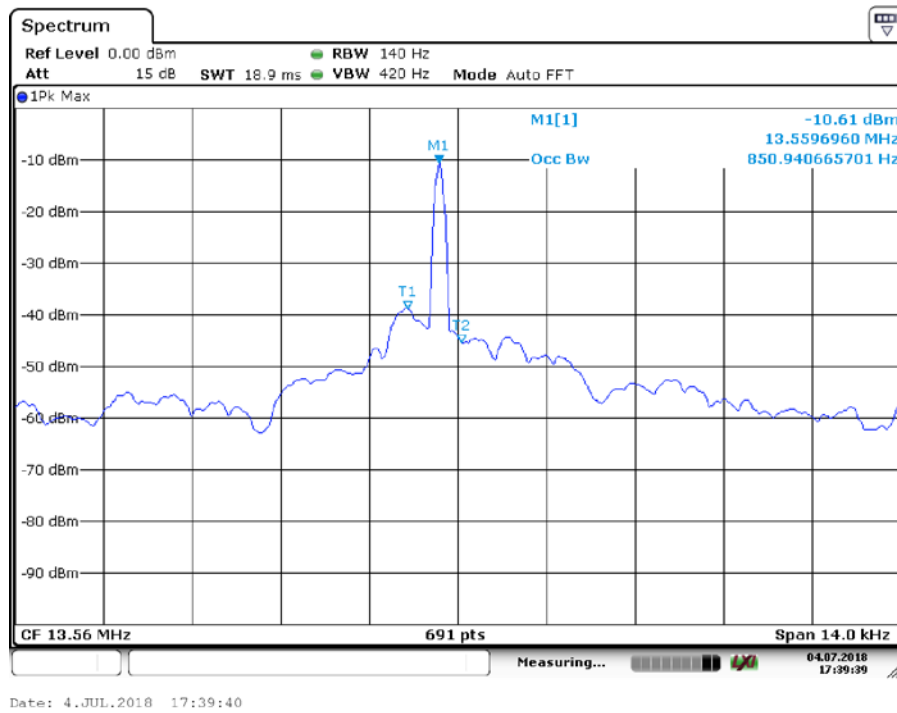

Figure A-7 Test result of EUT1 at test set. NFC03

A.7.7. Measurement Uncertainty

Measurement uncertainty: $U = 77 \text{ Hz}$, $k=2$

END OF REPORT