

Test of Spectralink 8741 Basic IP Telephone

To: FCC 47 CFR Part 15.247 & IC RSS-210

Test Report Serial No.: SPEC27-U4 Rev A



TEST REPORT

FROM



Test of Spectralink 8741 Basic IP Telephone

to

To FCC 47 CFR Part 15.247 & IC RSS-210

Test Report Serial No.: SPEC27-U4 Rev A

Note: this report contains data with regard to the 2400 to 2483.5 MHz operational modes of the Spectralink 8741 Basic IP Telephone. 5,150 – 5250, 5,250 – 5,350 and 5,470 – 5,725 MHz test data are reported in MiCOM Labs test report SPEC27-U8

This report supersedes: NONE

Applicant: Spectralink Corporation
2560 55th Street,
Boulder, Colorado, 80301
USA

Product Function: Wireless Telephony

Copy No: pdf Issue Date: 1st January 2014

This Test Report is Issued Under the Authority of:

MiCOM Labs, Inc.
575 Boulder Court
Pleasanton, CA 94566 USA
Phone: +1 (925) 462-0304
Fax: +1 (925) 462-0306
www.micomlabs.com



TESTING CERT #2381.U1

MiCOM Labs is an ISO 17025 Accredited Testing Laboratory



Title: Spectralink 8741 Basic IP Telephone
To: FCC 47 CFR Part 15.247 & IC RSS-210
Serial #: SPEC27-U4 Rev A
Issue Date: 1st January 2014
Page: 3 of 154

This page has been left intentionally blank



TABLE OF CONTENTS

ACCREDITATION, LISTINGS & RECOGNITION	5
ACCREDITATION & LISTINGS	5
RECOGNITION	6
PRODUCT CERTIFICATION	7
1. TEST RESULT CERTIFICATE	9
2. REFERENCES AND MEASUREMENT UNCERTAINTY	10
2.1. Normative References	10
2.2. Test and Uncertainty Procedures	11
3. PRODUCT DETAILS AND TEST CONFIGURATIONS	12
3.1. Technical Details	12
3.2. Scope of Test Program	14
3.3. Equipment Model(s) and Serial Number(s)	16
3.4. Antenna Details	16
3.5. Cabling and I/O Ports	16
3.6. Test Configurations	17
3.7. Equipment Modifications	18
3.8. Deviations from the Test Standard	18
4. TEST EQUIPMENT CONFIGURATION(S)	19
4.1. Conducted RF Emission Test Set-up	19
4.2. Radiated Spurious Emission Test Set-up > 1 GHz	20
4.3. Digital Emissions Test Set-up (0.03 – 1 GHz)	21
4.4. ac Wireline Emission Test Set-up	22
5. TEST SUMMARY	23
6. TEST RESULTS	25
6.1. Device Characteristics	25
6.1.1. <i>Conducted Testing</i>	25
6.1.2. <i>Radiated Emission Testing</i>	54
6.1.3. <i>AC Wireline Conducted Emissions (150 kHz – 30 MHz)</i>	75
7. PHOTOGRAPHS	79
7.1. Test Setup – RF Conducted	79
7.2. Test Setup - Digital Emissions 0.03 - 1 GHz	80
7.3. Test Setup - Spurious Emissions > 1 GHz	81
8. TEST EQUIPMENT	82
APPENDIX	83
A. SUPPORTING INFORMATION	83
A.1. CONDUCTED TEST PLOTS	83
A.1.1. <i>6 dB & 99% Bandwidth</i>	84
A.1.2. <i>Peak Output Power</i>	99
A.1.3. <i>Power Spectral Density</i>	114
A.1.4. <i>Conducted Spurious Emissions</i>	129

This test report may be reproduced in full only. The document may only be updated by MiCOM Labs personnel. Any changes will be noted in the Document History section of the report.

ACCREDITATION, LISTINGS & RECOGNITION

ACCREDITATION & LISTINGS

MiCOM Labs, Inc. an accredited laboratory complies with the international standard BS EN ISO/IEC 17025. The company is accredited by the American Association for Laboratory Accreditation (A2LA) www.a2la.org test laboratory number 2381.01. MiCOM Labs test schedule is available at the following URL; <http://www.a2la.org/scopepdf/2381-01.pdf>



The American Association for Laboratory Accreditation

World Class Accreditation

Accredited Laboratory

A2LA has accredited

MICOM LABS

Pleasanton, CA

for technical competence in the field of

Electrical Testing

This laboratory is accredited in accordance with the recognized International Standard ISO/IEC 17025:2005 *General Requirements for the Competence of Testing and Calibration Laboratories*. This accreditation demonstrates technical competence for a defined scope and the operation of a laboratory quality management system (refer to joint ISO-ILAC-IAF Communiqué dated 8 January 2009).

Presented this 27th day of March 2012.



President & CEO
For the Accreditation Council
Certificate Number 2381.01
Valid to February 28, 2014
Revised November 11, 2013

For the tests or types of tests to which this accreditation applies, please refer to the laboratory's Electrical Scope of Accreditation.

This test report may be reproduced in full only. The document may only be updated by MiCOM Labs personnel. Any changes will be noted in the Document History section of the report.



RECOGNITION

MiCOM Labs, Inc has widely recognized Electrical testing capabilities. Our international recognition includes Conformity Assessment Body designation by APEC MRA** countries. Our test reports are widely accepted for global type approvals.

Country	Recognition Body	Status	Phase	Identification No.
USA	Federal Communications Commission (FCC)	TCB	-	US0159 Listing #: 102167
Canada	Industry Canada (IC)	FCB	APEC MRA 2	US0159 Listing #: 4143A-2 4143A-3
Japan	MIC (Ministry of Internal Affairs and Communication)	CAB	APEC MRA 2	RCB 210
	VCCI	--	--	A-0012
Europe	European Commission	NB	EU MRA	NB 2280
Australia	Australian Communications and Media Authority (ACMA)	CAB	APEC MRA 1	US0159
Hong Kong	Office of the Telecommunication Authority (OFTA)	CAB	APEC MRA 1	
Korea	Ministry of Information and Communication Radio Research Laboratory (RRL)	CAB	APEC MRA 1	
Singapore	Infocomm Development Authority (IDA)	CAB	APEC MRA 1	
Taiwan	National Communications Commission (NCC) Bureau of Standards, Metrology and Inspection (BSMI)	CAB	APEC MRA 1	
Vietnam	Ministry of Communication (MIC)	CAB	APEC MRA 1	

**APEC MRA – Asia Pacific Economic Community Mutual Recognition Agreement.

Is a recognition agreement under which test lab is accredited to regulatory standards of the APEC member countries.

Phase I - recognition for product testing

Phase II – recognition for both product testing and certification

N/A – Not Applicable

**EU MRA – European Union Mutual Recognition Agreement.

Is a recognition agreement under which test lab is accredited to regulatory standards of the EU member countries.

**NB – Notified Body

This test report may be reproduced in full only. The document may only be updated by MiCOM Labs personnel. Any changes will be noted in the Document History section of the report.



Title: Spectralink 8741 Basic IP Telephone
To: FCC 47 CFR Part 15.247 & IC RSS-210
Serial #: SPEC27-U4 Rev A
Issue Date: 1st January 2014
Page: 7 of 154

PRODUCT CERTIFICATION

MiCOM Labs, Inc. is an accredited Product Certification Body per the international standard EN ISO/IEC Guide 65. The company is accredited by the American Association for Laboratory Accreditation (A2LA) www.a2la.org test laboratory number 2381.02. MiCOM Labs test schedule is available at the following URL; <http://www.a2la.org/scopepdf/2381-02.pdf>



The American Association for Laboratory Accreditation

"World Class Accreditation"

Accredited Product Certification Body

A2LA has accredited

MICOM LABS

Pleasanton, CA

for technical competence as a

Product Certification Body

This product certification body is accredited in accordance with the recognized International Standard ISO/IEC Guide 65:1996 *General requirements for bodies operating product certification systems*. This accreditation demonstrates technical competence for a defined scope and the operation of a quality management system.

Presented this 27th day of March 2012.



Peter Ahjja

President & CEO

For the Accreditation Council
Certificate Number 2381.02
Valid to February 28, 2014
Revised November 11, 2013

For the product certification schemes to which this accreditation applies, please refer to the organization's Product Certification Scope of Accreditation

United States of America – Telecommunication Certification Body (TCB)

TCB Identifier – US0159

Industry Canada – Certification Body

CAB Identifier – US0159

Europe – Notified Body

Notified Body Identifier - 2280

Japan – Recognized Certification Body (RCB)

RCB Identifier - 210

This test report may be reproduced in full only. The document may only be updated by MiCOM Labs personnel. Any changes will be noted in the Document History section of the report.



Title: Spectralink 8741 Basic IP Telephone
To: FCC 47 CFR Part 15.247 & IC RSS-210
Serial #: SPEC27-U4 Rev A
Issue Date: 1st January 2014
Page: 8 of 154

DOCUMENT HISTORY

Document History		
Revision	Date	Comments
Draft		
Rev A	1 st January 2014	Initial release

This test report may be reproduced in full only. The document may only be updated by MiCOM Labs personnel. Any changes will be noted in the Document History section of the report.



Title: Spectralink 8741 Basic IP Telephone
To: FCC 47 CFR Part 15.247 & IC RSS-210
Serial #: SPEC27-U4 Rev A
Issue Date: 1st January 2014
Page: 9 of 154

1. TEST RESULT CERTIFICATE

Manufacturer:	Spectralink Corporation 2560 55th Street, Boulder, Colorado, 80301 USA	Tested By:	MiCOM Labs, Inc. 575 Boulder Court Pleasanton California, 94566, USA
EUT:	Wireless Telephony	Telephone:	+1 925 462 0304
Model:	8741 Basic	Fax:	+1 925 462 0306
S/N's:	Development Model		
Test Date(s):	30th Oct - 17th Nov 2013	Website:	www.micomlabs.com

STANDARD(S)	TEST RESULTS
FCC 47 CFR Part 15.247 & IC RSS-210	EQUIPMENT COMPLIES

MiCOM Labs, Inc. tested the equipment mentioned in accordance with the requirements set forth in the above standards. Test results indicate that the equipment tested is capable of demonstrating compliance with the requirements as documented within this report.

Notes:

1. This document reports conditions under which testing was conducted and the results of testing performed.
2. Details of test methods used have been recorded and kept on file by the laboratory.
3. Test results apply only to the item(s) tested.

Approved & Released for MiCOM Labs, Inc. by:



TESTING CERT #2381.01



Graeme Grieve
Quality Manager MiCOM Labs,

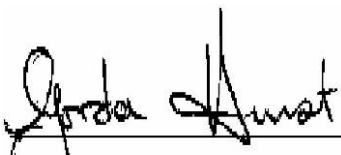

Gordon Hurst
President & CEO MiCOM Labs, Inc.

This test report may be reproduced in full only. The document may only be updated by MiCOM Labs personnel. Any changes will be noted in the Document History section of the report.

2. REFERENCES AND MEASUREMENT UNCERTAINTY

2.1. Normative References

REF.	PUBLICATION	YEAR	TITLE
i.	FCC 47 CFR Part 15, Subpart C	2013	Title 47: Telecommunication PART 15—RADIO FREQUENCY DEVICES Subpart C—Intentional Radiators
ii.	RSS-210 Annex 8	2010	Radio Standards Specification 210, Issue 8, Low-power Licence-exempt Radiocommunication Devices (All Frequency Bands): Category I Equipment
iii.	FCC OET KDB 662911	4 th April 2011	Emissions Testing of Transmitters with Multiple Outputs in the Same Band
iv.	DA 00-705	2000	FCC DA 00-705 "Filing and Measurement Guidelines for Frequency Hopping Spread Spectrum Systems" released March 30, 2000
v.	RSS-GEN	2010	Radio Standards Specification-Gen, Issue 3, General Requirements and Information for the Certification of Radiocommunication Equipment
vi.	FCC 47 CFR Part 15, Subpart B	2010	47 CFR Part 15, SubPart B; Unintentional Radiators
vii.	ICES-003	2004	Spectrum Management and Telecommunications Policy Interference-Causing Equipment Standard Digital Apparatus; Issue 4
viii.	ANSI C63.4	2009	American National Standards for Methods of Measurement of Radio-Noise Emissions from Low-Voltage Electrical and Electronic Equipment in the Range of 9 kHz to 40 GHz
ix.	CISPR 22/ EN 55022	2008 2006+A1:2007	Limits and Methods of Measurements of Radio Disturbance Characteristics of Information Technology Equipment
x.	M 3003	Edition 2 Jan. 2007	Expression of Uncertainty and Confidence in Measurements
xi.	LAB34	Edition 1 Aug 2002	The expression of uncertainty in EMC Testing
xii.	ETSI TR 100 028	2001	Parts 1 and 2 Electromagnetic compatibility and Radio Spectrum Matters (ERM); Uncertainties in the measurement of mobile radio equipment characteristics
xiii.	A2LA	July 2012	Reference to A2LA Accreditation Status – A2LA Advertising Policy

This test report may be reproduced in full only. The document may only be updated by MiCOM Labs personnel. Any changes will be noted in the Document History section of the report.



Title: Spectralink 8741 Basic IP Telephone
To: FCC 47 CFR Part 15.247 & IC RSS-210
Serial #: SPEC27-U4 Rev A
Issue Date: 1st January 2014
Page: 11 of 154

2.2. Test and Uncertainty Procedures

Conducted and radiated emission measurements were conducted in accordance with American National Standards Institute ANSI C63.4, listed in the Normative References section of this report.

Measurement uncertainty figures are calculated in accordance with ETSI TR 100 028 Parts 1 and 2.

Measurement uncertainties stated are based on a standard uncertainty multiplied by a coverage factor $k = 2$, providing a level of confidence of approximately 95 % in accordance with UKAS document M 3003 listed in the Normative References section of this report.

This test report may be reproduced in full only. The document may only be updated by MiCOM Labs personnel. Any changes will be noted in the Document History section of the report.



Title: Spectralink 8741 Basic IP Telephone
To: FCC 47 CFR Part 15.247 & IC RSS-210
Serial #: SPEC27-U4 Rev A
Issue Date: 1st January 2014
Page: 12 of 154

3. PRODUCT DETAILS AND TEST CONFIGURATIONS

3.1. Technical Details

Details	Description
Purpose:	Test of the Spectralink 8741 Basic IP Telephone Wireless IP telephone to FCC Part 15.247 and Industry Canada RSS-210 regulations.
Applicant:	Spectralink Corporation 2560 55th Street, Boulder, Colorado, 80301 USA
Manufacturer:	Celestica (Thailand) Ltd 49/18 Moo 5, Laem Chabang Industrial Estate Tungsohkhla, Chonburi, Thailand 20230
Laboratory performing the tests:	MiCOM Labs, Inc. 575 Boulder Court Pleasanton, California 94566 USA
Test report reference number:	SPEC27-U4 Rev A
Date EUT received:	24 th October 2013
Standard(s) applied:	FCC 47 CFR Part 15.247 & IC RSS-210
Dates of test (from - to):	30th Oct - 17th Nov 2013
No of Units Tested:	One for radiated testing : test code
Type of Equipment:	Wireless IP Telephone
Manufacturers Trade Name:	Spectralink
Model(s):	8741 Basic
Location for use:	Indoor
Declared Frequency Range(s):	2400 - 2483.5 MHz & 5725 – 5850 MHz
Hardware Rev	930-0002-003Rev X1
Software Rev	Build 1835
Type of Modulation:	Per 802.11 – CCK, OFDM
Declared Nominal Average Output Power:	+20 dBm
EUT Modes of Operation:	802.11a,b,g,n HT-20
Transmit/Receive Operation:	Time Division Duplex
System Beam Forming:	EUT has no capability for antenna beam forming
Rated Input Voltage and Current:	3.6 Vdc (Battery)
Operating Temperature Range:	Declared range 0° to +40°C

This test report may be reproduced in full only. The document may only be updated by MiCOM Labs personnel. Any changes will be noted in the Document History section of the report.



Title: Spectralink 8741 Basic IP Telephone
To: FCC 47 CFR Part 15.247 & IC RSS-210
Serial #: SPEC27-U4 Rev A
Issue Date: 1st January 2014
Page: 13 of 154

ITU Emission Designator:	<u>2400 – 2483.5 MHz</u> 802.11b 16M2G1D 802.11g 17M4D1D 802.11n – HT-20 18M0D1D <u>5725 – 5850 MHz</u> 802.11a 24M6D1D 802.11n HT-20 25M4D1D
Equipment Dimensions:	144.6 (h) x 77.2 (w) x 27.3 (t) mm
Weight:	240 grams
Primary function of equipment:	Wireless Telephony

This test report may be reproduced in full only. The document may only be updated by MiCOM Labs personnel. Any changes will be noted in the Document History section of the report.

3.2. Scope of Test Program

Spectralink 8741 Basic IP Telephone RF Testing

The scope of the test program was to test the Spectralink 8741 Basic IP Telephone, in the frequency range 2400 - 2483.5 MHz and 5725 – 5850 MHz for compliance against FCC 47 CFR Part 15.247 and Industry Canada RSS-210 specifications.

Note: As the basic and Enhanced Phone with barcode reader use the same RF Module conducted test data from the worst case Enhanced with Barcode reader phone was used to generate this report. Radiated emission data (0.03 – 1 GHz and above 1 GHz) from the Basic Phone have been included in this report

Spectralink 8741 Basic IP Telephone (Front)



This test report may be reproduced in full only. The document may only be updated by MiCOM Labs personnel. Any changes will be noted in the Document History section of the report.

Spectralink 8741 Basic IP Telephone (Rear)



This test report may be reproduced in full only. The document may only be updated by MiCOM Labs personnel. Any changes will be noted in the Document History section of the report.



3.3. Equipment Model(s) and Serial Number(s)

Equipment Type	Equipment Description (Including Brand Name)	Mfr	Model No.	Serial No.
EUT	Wireless IP Phone (Radiated Test Phone)	Spectralink	8741	Development Model
Support	Laptop PC	IBM	Thinkpad	None

3.4. Antenna Details

Antenna Type	Manufacturer	Model Number	Antenna Gain (dBi)	
			2.4 GHz	5 GHz
Plated on PCB	Spectralink	Not Applicable	1.2	4.0

3.5. Cabling and I/O Ports

Number and type of I/O ports

1. 1 x Micro USB On The Go (OTG) + Charging



3.6. Test Configurations

Testing was performed to determine the highest power level versus bit rate. The variant with the highest power was used to exercise the product.

Operational Mode(s) (802.11a/b/g/n)	Variant	Data Rate with Highest Power	Frequencies (MHz)
b	Legacy	1 MBit/s	2,412 2,437 2,462
g	Legacy	6 MBit/s	
n	HT-20	6.5 (MCS 0)	
a	Legacy	6 MBit/s	5,745 5,785 5,825
n	HT-20	6.5 (MCS 0)	

Results for the above configurations are provided in this report.

Antenna Test Configurations for Radiated Emissions

Results for the following configurations are provided in this report.



2,400 – 2483.5 MHz

5,725 – 5850 MHz

15.247	
802.11b	b SE 2412
	b SE 2437
	b SE 2462
	BE b 2390
	BE b 2483.5
802.11g	g SE 2412
	g SE 2437
	g SE 2462
	BE g 2390
	BE g 2483.5
802.11n HT-20	n HT-20 SE 2412
	n HT-20 SE 2437
	n HT-20 SE 2462
	BE n HT-20 2390
	BE n HT-20 2483.5

15.247	
802.11a	a SE 5745
	a SE 5785
	a SE 5825
802.11n HT-20	n HT-20 SE 5745
	n HT-20 SE 5785
	n HT-20 SE 5825

KEY;-

SE – Spurious Emission
BE – Band-Edge

3.7. Equipment Modifications

The following modifications were required to bring the equipment into compliance:

1. NONE

3.8. Deviations from the Test Standard

The following deviations from the test standard were required in order to complete the test program:

1. NONE

4. TEST EQUIPMENT CONFIGURATION(S)

4.1. Conducted RF Emission Test Set-up

The following tests were performed using the conducted test set-up shown in the diagram below.

1. Section 6.1.1.1. 6 dB and 99% Bandwidth
2. Section 6.1.1.2. Peak Output Power
3. Section 6.1.1.3. Power Spectral Density
4. Section 6.1.1.4. Conducted Spurious Emissions

Conducted Test Set-Up Pictorial Representation

Test Measurement set up

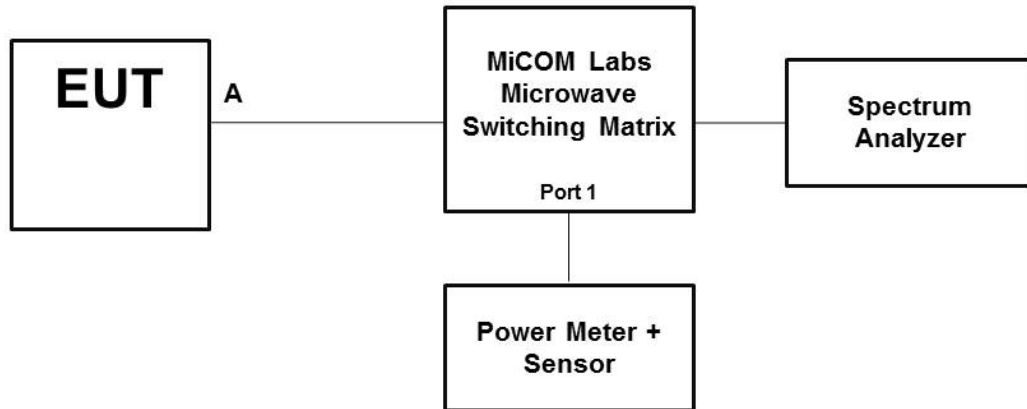

Conducted Test Measurement Setup

This test report may be reproduced in full only. The document may only be updated by MiCOM Labs personnel. Any changes will be noted in the Document History section of the report.

4.2. Radiated Spurious Emission Test Set-up > 1 GHz

The following tests were performed using the conducted test set-up shown in the diagram below.

Radiated Emission Measurement Setup – Above 1 GHz

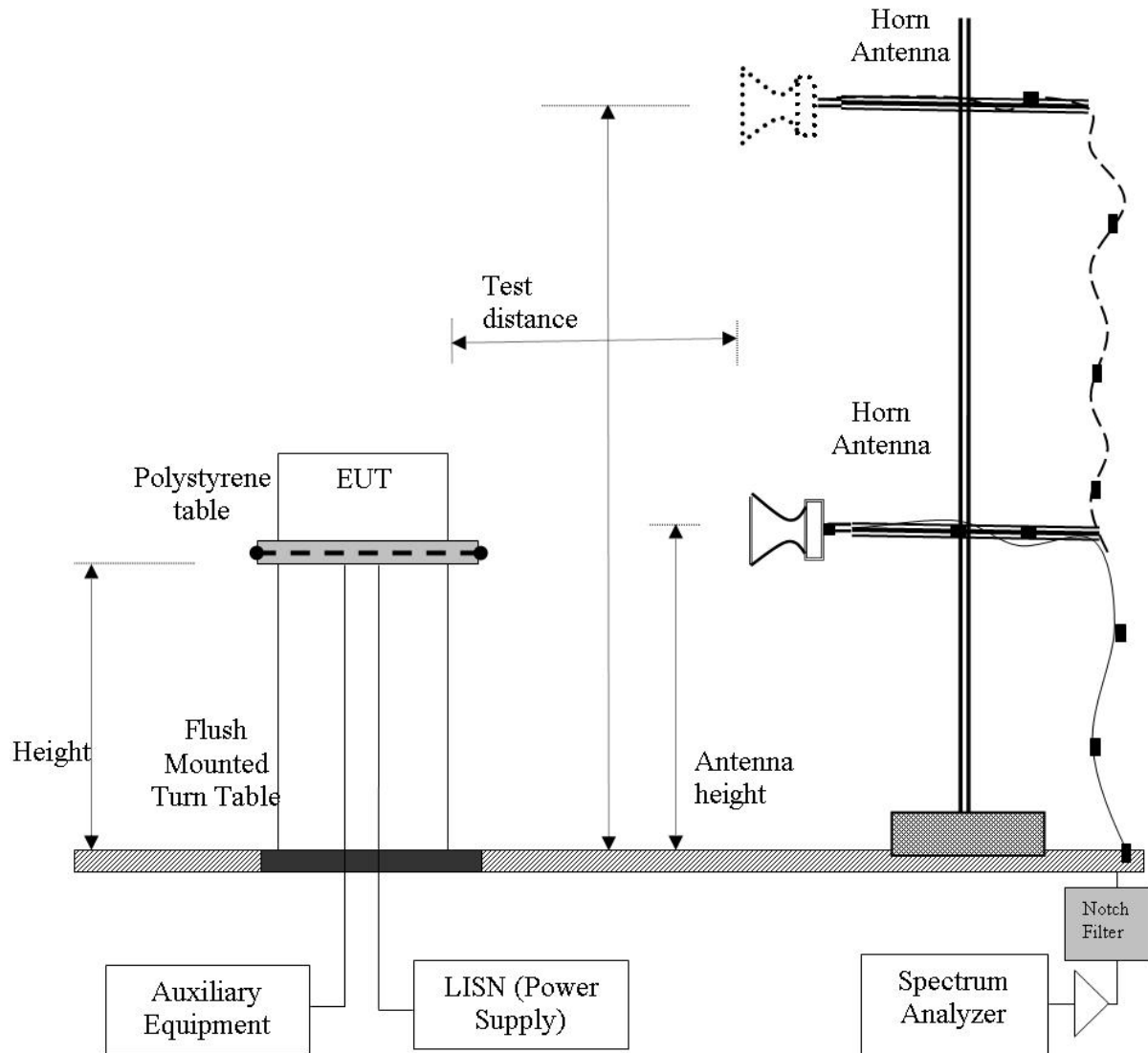

This test report may be reproduced in full only. The document may only be updated by MiCOM Labs personnel. Any changes will be noted in the Document History section of the report.

4.3. Digital Emissions Test Set-up (0.03 – 1 GHz)

The following tests were performed using the conducted test set-up shown in the diagram below.

Digital Emission Measurement Setup – Below 1 GHz

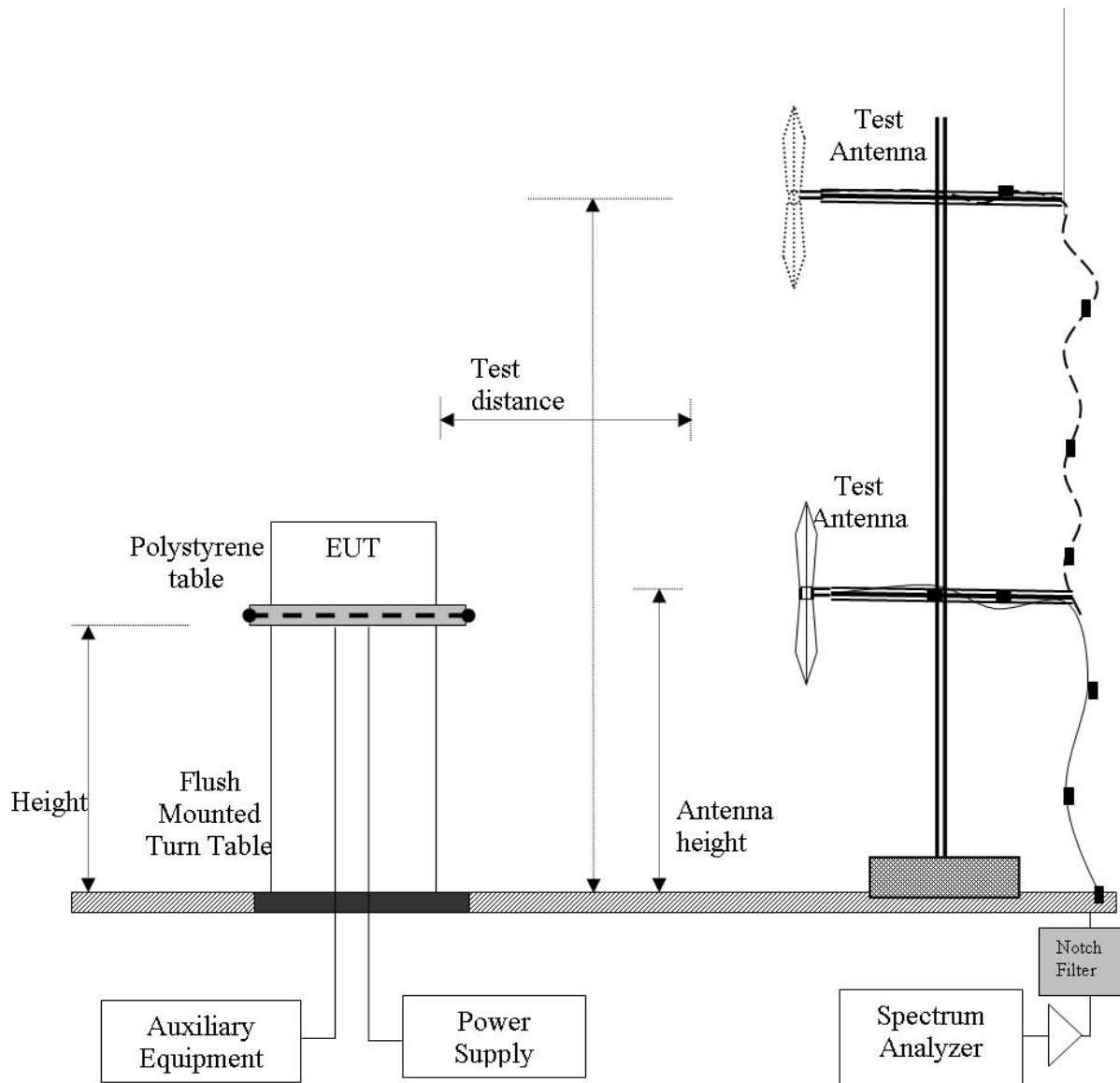

4.4. ac Wireline Emission Test Set-up

The following tests were performed using the conducted test set-up shown in the diagram below.

1. Section 6.1.3 ac Wireline Conducted Emissions

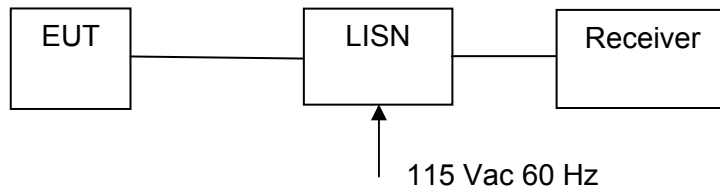

Measurement Setup for Conducted Emissions Test



5. TEST SUMMARY

List of Measurements

The following table represents the list of measurements required under the **FCC CFR47 Part 15.247** and **Industry Canada RSS-210** and **Industry Canada RSS-Gen**.

Section(s)	Test Items	Description	Condition	Result	Test Report Section
15.247(a)(2) A8.2(1) 4.4	6 dB and 99 % Bandwidths	≥500 kHz	Conducted	Complies	6.1.1.1
15.247(b)(3) 15.31(e) A8.4(4)	Peak Output Power Voltage Variation	Shall not exceed 1W Variation of supply voltage 85 % -115 %	Conducted	Complies	6.1.1.2
15.247(e) A8.2	Peak Power Spectral Density	Shall not be greater than +8 dBm in any 3 kHz band	Conducted	Complies	6.1.1.3
15.247(d) 15.205 / 15.209 A8.5 2.2 4.7	Spurious Emissions (30MHz - 26 GHz b/g and 30 MHz – 40 GHz a)	The radiated emission in any 100 kHz of out- band shall be at least 20 dB below the highest in- band spectral density	Conducted	Complies	6.1.1.4
15.247(i) 5.5	Maximum Permissible Exposure	Exposure to radio frequency energy levels	Conducted	Complies	6.1.1.5

This test report may be reproduced in full only. The document may only be updated by MiCOM Labs personnel. Any changes will be noted in the Document History section of the report.



List of Measurements (continued)

The following table represents the list of measurements required under the **FCC CFR47 Part 15.247**, **Industry Canada RSS-210**, and **Industry Canada RSS-Gen**.

Section(s)	Test Items	Description	Condition	Result	Test Report Section
15.247(d) 15.205 / 15.209 A8.5 2.2 2.6 4.7	Radiated Emissions	Restricted Bands	Radiated	Complies	6.1.2
	Transmitter Radiated Spurious Emissions	Emissions above 1 GHz		Complies	
	Radiated Band Edge	Band-edge results Peak Emissions		Complies	
15.205 / 15.209 2.2	Radiated Spurious Emissions	Emissions <1 GHz (30M-1 GHz)	Radiated	Complies	6.1.2.1
15.207 7.2.2	AC Wireline Conducted Emissions 150 kHz– 30 MHz	Conducted Emissions	Conducted	Complies	6.1.3

Note 1: Test results reported in this document relate only to the items tested

Note 2: The required tests demonstrated compliance as per client declaration of test configuration, monitoring methodology and associated pass/fail criteria

Note 3: Section 3.7 Equipment Modifications highlights the equipment modifications that were required to bring the product into compliance with the above test matrix



Title: Spectralink 8741 Basic IP Telephone
To: FCC 47 CFR Part 15.247 & IC RSS-210
Serial #: SPEC27-U4 Rev A
Issue Date: 1st January 2014
Page: 25 of 154

6. TEST RESULTS

6.1. Device Characteristics

6.1.1. Conducted Testing

6.1.1.1. 6 dB and 99 % Bandwidth

Conducted Test Conditions for 6 dB and 99% Bandwidth			
Standard:	FCC CFR 47:15.247	Ambient Temp. (°C):	24.0 - 27.5
Test Heading:	6 dB and 99 % Bandwidth	Rel. Humidity (%):	32 - 45
Standard Section(s):	15.247 (a)(2)	Pressure (mBars):	999 - 1001
Reference Document(s):	KDB 558074 - D01 DTS Measurement Guidance v01: Section 5.1 Emission Bandwidth		

Test Procedure for 6 dB and 99% Bandwidth Measurement
The bandwidth at 6 dB and 99 % was measured with a spectrum analyzer connected to the antenna terminal, while EUT is operating in transmission mode at the appropriate centre frequency.

This test report may be reproduced in full only. The document may only be updated by MiCOM Labs personnel. Any changes will be noted in the Document History section of the report.



Title: Spectralink 8741 Basic IP Telephone
To: FCC 47 CFR Part 15.247 & IC RSS-210
Serial #: SPEC27-U4 Rev A
Issue Date: 1st January 2014
Page: 26 of 154

Equipment Configuration for 6 dB & 99% Bandwidth

Variant:	802.11b	Duty Cycle (%):	99
Data Rate:	1 MBit/s	Antenna Gain (dBi):	Not Applicable
Modulation:	CCK	Beam Forming Gain (Y):	Not Applicable
TPC:	Not Applicable	Tested By:	CC
Engineering Test Notes:			

Test Measurement Results

Test Frequency MHz	Measured 6 dB Bandwidth (MHz) Port(s)				6 dB Bandwidth (MHz)		Limit KHz	Lowest Margin MHz
	a	b	c	d	Highest	Lowest		
2412.0	10.180	--	--	--	10.180	10.180	≥500.0	-9.68
2437.0	10.180	--	--	--	10.180	10.180	≥500.0	-9.68
2462.0	10.180	--	--	--	10.180	10.180	≥500.0	-9.68

Test Frequency MHz	Measured 99% Bandwidth (MHz) Port(s)				Maximum 99% Bandwidth (MHz)		
	a	b	c	d			
2412.0	16.192	--	--	--	16.192		
2437.0	16.112	--	--	--	16.112		
2462.0	16.112	--	--	--	16.112		

Traceability to Industry Recognized Test Methodologies

Work Instruction:	WI-03 MEASURING RF SPECTRUM MASK
Measurement Uncertainty:	±2.81 dB

Note: [click the link in the above results matrix to view the plot](#)

This test report may be reproduced in full only. The document may only be updated by MiCOM Labs personnel. Any changes will be noted in the Document History section of the report.



Title: Spectralink 8741 Basic IP Telephone
To: FCC 47 CFR Part 15.247 & IC RSS-210
Serial #: SPEC27-U4 Rev A
Issue Date: 1st January 2014
Page: 27 of 154

Equipment Configuration for 6 dB & 99% Bandwidth

Variant:	802.11g	Duty Cycle (%):	99
Data Rate:	6 MBit/s	Antenna Gain (dBi):	Not Applicable
Modulation:	OFDM	Beam Forming Gain (Y):	Not Applicable
TPC:	Not Applicable	Tested By:	CC
Engineering Test Notes:			

Test Measurement Results

Test Frequency MHz	Measured 6 dB Bandwidth (MHz) Port(s)				6 dB Bandwidth (MHz)		Limit KHz	Lowest Margin MHz
	a	b	c	d	Highest	Lowest		
2412.0	15.792	--	--	--	15.792	15.792	≥500.0	-15.29
2437.0	15.792	--	--	--	15.792	15.792	≥500.0	-15.29
2462.0	15.792	--	--	--	15.792	15.792	≥500.0	-15.29

Test Frequency MHz	Measured 99% Bandwidth (MHz) Port(s)				Maximum 99% Bandwidth (MHz)		
	a	b	c	d			
2412.0	17.395	--	--	--	17.395		
2437.0	16.994	--	--	--	16.994		
2462.0	16.834	--	--	--	16.834		

Traceability to Industry Recognized Test Methodologies

Work Instruction:	WI-03 MEASURING RF SPECTRUM MASK
Measurement Uncertainty:	±2.81 dB

Note: [click the link in the above results matrix to view the plot](#)

This test report may be reproduced in full only. The document may only be updated by MiCOM Labs personnel. Any changes will be noted in the Document History section of the report.



Title: Spectralink 8741 Basic IP Telephone
To: FCC 47 CFR Part 15.247 & IC RSS-210
Serial #: SPEC27-U4 Rev A
Issue Date: 1st January 2014
Page: 28 of 154

Equipment Configuration for 6 dB & 99% Bandwidth

Variant:	802.11n HT-20	Duty Cycle (%):	99
Data Rate:	6.5 MBit/s	Antenna Gain (dBi):	Not Applicable
Modulation:	OFDM	Beam Forming Gain (Y):	Not Applicable
TPC:	Not Applicable	Tested By:	CC
Engineering Test Notes:			

Test Measurement Results

Test Frequency MHz	Measured 6 dB Bandwidth (MHz)				6 dB Bandwidth (MHz)		Limit KHz	Lowest Margin MHz
	Port(s)				Highest	Lowest		
	a	b	c	d				
2412.0	16.273	--	--	--	16.273	16.273	≥500.0	-15.77
2437.0	15.952	--	--	--	15.952	15.952	≥500.0	-15.45
2462.0	15.872	--	--	--	15.872	15.872	≥500.0	-15.37

Test Frequency MHz	Measured 99% Bandwidth (MHz)				Maximum 99% Bandwidth (MHz)		
	Port(s)						
	a	b	c	d			
2412.0	18.036	--	--	--	18.036		
2437.0	17.876	--	--	--	17.876		
2462.0	17.876	--	--	--	17.876		

Traceability to Industry Recognized Test Methodologies

Work Instruction:	WI-03 MEASURING RF SPECTRUM MASK
Measurement Uncertainty:	±2.81 dB

Note: [click the link in the above results matrix to view the plot](#)

This test report may be reproduced in full only. The document may only be updated by MiCOM Labs personnel. Any changes will be noted in the Document History section of the report.



Title: Spectralink 8741 Basic IP Telephone
To: FCC 47 CFR Part 15.247 & IC RSS-210
Serial #: SPEC27-U4 Rev A
Issue Date: 1st January 2014
Page: 29 of 154

Equipment Configuration for 6 dB & 99% Bandwidth

Variant:	802.11a	Duty Cycle (%):	99
Data Rate:	6 MBit/s	Antenna Gain (dBi):	Not Applicable
Modulation:	OFDM	Beam Forming Gain (Y):	Not Applicable
TPC:	Not Applicable	Tested By:	CC
Engineering Test Notes:			

Test Measurement Results

Test Frequency MHz	Measured 6 dB Bandwidth (MHz) Port(s)				6 dB Bandwidth (MHz)		Limit KHz	Lowest Margin MHz
	a	b	c	d	Highest	Lowest		
5745.0	15.471	--	--	--	15.471	15.471	≥500.0	-14.97
5785.0	16.032	--	--	--	16.032	16.032	≥500.0	-15.53
5825.0	15.471	--	--	--	15.471	15.471	≥500.0	-14.97

Test Frequency MHz	Measured 99% Bandwidth (MHz) Port(s)				Maximum 99% Bandwidth (MHz)		
	a	b	c	d			
5745.0	24.208	--	--	--	24.208		
5785.0	24.770	--	--	--	24.770		
5825.0	24.609	--	--	--	24.609		

Traceability to Industry Recognized Test Methodologies

Work Instruction:	WI-03 MEASURING RF SPECTRUM MASK
Measurement Uncertainty:	±2.81 dB

Note: [click the link in the above results matrix to view the plot](#)

This test report may be reproduced in full only. The document may only be updated by MiCOM Labs personnel. Any changes will be noted in the Document History section of the report.



Title: Spectralink 8741 Basic IP Telephone
To: FCC 47 CFR Part 15.247 & IC RSS-210
Serial #: SPEC27-U4 Rev A
Issue Date: 1st January 2014
Page: 30 of 154

Equipment Configuration for 6 dB & 99% Bandwidth

Variant:	802.11n HT-20	Duty Cycle (%):	99
Data Rate:	6.5 MBit/s	Antenna Gain (dBi):	Not Applicable
Modulation:	OFDM	Beam Forming Gain (Y):	Not Applicable
TPC:	Not Applicable	Tested By:	CC
Engineering Test Notes:			

Test Measurement Results

Test Frequency MHz	Measured 6 dB Bandwidth (MHz) Port(s)				6 dB Bandwidth (MHz)		Limit KHz	Lowest Margin MHz
	a	b	c	d	Highest	Lowest		
5745.0	15.631	--	--	--	15.631	15.631	≥500.0	-15.13
5785.0	16.433	--	--	--	16.433	16.433	≥500.0	-15.93
5825.0	15.631	--	--	--	15.631	15.631	≥500.0	-15.13

Test Frequency MHz	Measured 99% Bandwidth (MHz) Port(s)				Maximum 99% Bandwidth (MHz)		
	a	b	c	d			
5745.0	25.170	--	--	--	25.170		
5785.0	25.411	--	--	--	25.411		
5825.0	25.010	--	--	--	25.010		

Traceability to Industry Recognized Test Methodologies

Work Instruction:	WI-03 MEASURING RF SPECTRUM MASK
Measurement Uncertainty:	±2.81 dB

Note: [click the link in the above results matrix to view the plot](#)

This test report may be reproduced in full only. The document may only be updated by MiCOM Labs personnel. Any changes will be noted in the Document History section of the report.



Title: Spectralink 8741 Basic IP Telephone
To: FCC 47 CFR Part 15.247 & IC RSS-210
Serial #: SPEC27-U4 Rev A
Issue Date: 1st January 2014
Page: 31 of 154

Specification

Limits

§15.247 (a)(2) & RSS-210 §A8.2(a)

The minimum 6 dB bandwidth shall be at least 500 kHz.

Traceability

Test Equipment Used

0158, 0287, 0252, 0313, 0314, 0070, 0116, 0117
--

This test report may be reproduced in full only. The document may only be updated by MiCOM Labs personnel. Any changes will be noted in the Document History section of the report.



Title: Spectralink 8741 Basic IP Telephone
To: FCC 47 CFR Part 15.247 & IC RSS-210
Serial #: SPEC27-U4 Rev A
Issue Date: 1st January 2014
Page: 32 of 154

6.1.1.2. Peak Output Power

Conducted Test Conditions for Fundamental Emission Output Power			
Standard:	FCC CFR 47:15.247	Ambient Temp. (°C):	24.0 - 27.5
Test Heading:	Emission Output Power	Rel. Humidity (%):	32 - 45
Standard Section(s):	15.247 (a)(2)	Pressure (mBars):	999 - 1004
Reference Document(s):	KDB 558074 - D01 DTS Measurement Guidance v01: Section 5.2 Fundamental Emission Output Power KDB 662911 was implemented for In-band power measurements. The measure and sum technique was implemented in all cases.		
Test Procedure for Fundamental Emission Output Power Measurement The transmitter terminal of EUT was connected to the input of the spectrum analyzer set to measure peak power. The resolution filter bandwidth was set to 6 dB, peak detector selected and the analyzer built-in power function was used to integrate peak power over the 20 dB bandwidth.			
Supporting Information Calculated Power = A + G + 10 log (1/x) dBm A = Total Power [10 Log10 (10 ^{a/10} + 10 ^{b/10} + 10 ^{c/10} + 10 ^{d/10})], G = Antenna Gain, x = Duty Cycle			

This test report may be reproduced in full only. The document may only be updated by MiCOM Labs personnel. Any changes will be noted in the Document History section of the report.



Title: Spectralink 8741 Basic IP Telephone
To: FCC 47 CFR Part 15.247 & IC RSS-210
Serial #: SPEC27-U4 Rev A
Issue Date: 1st January 2014
Page: 33 of 154

Equipment Configuration for Peak Output Power

Variant:	802.11b	Duty Cycle (%):	99
Data Rate:	1 MBit/s	Antenna Gain (dBi):	1.20
Modulation:	CCK	Beam Forming Gain (Y):	Not Applicable
TPC:	Not Applicable	Tested By:	CC
Engineering Test Notes:			

Test Measurement Results

Test Frequency MHz	Measured Output Power (dBm) Port(s)				Calculated Total Power Σ Port(s) dBm	Limit dBm	Margin dBm	EUT Power Setting
	a	b	c	d				
2412.0	26.62	--	--	--	26.62	30.00	-3.38	22.00
2437.0	26.72	--	--	--	26.72	30.00	-3.28	22.00
2462.0	26.96	--	--	--	26.96	30.00	-3.04	22.00

Traceability to Industry Recognized Test Methodologies

Work Instruction:	WI-01 MEASURING RF OUTPUT POWER
Measurement Uncertainty:	±1.33 dB

Note: [click the link in the above results matrix to view the plot](#)

This test report may be reproduced in full only. The document may only be updated by MiCOM Labs personnel. Any changes will be noted in the Document History section of the report.



Title: Spectralink 8741 Basic IP Telephone
To: FCC 47 CFR Part 15.247 & IC RSS-210
Serial #: SPEC27-U4 Rev A
Issue Date: 1st January 2014
Page: 34 of 154

Equipment Configuration for Peak Output Power

Variant:	802.11g	Duty Cycle (%):	99
Data Rate:	6 MBit/s	Antenna Gain (dBi):	1.20
Modulation:	OFDM	Beam Forming Gain (Y):	Not Applicable
TPC:	Not Applicable	Tested By:	CC
Engineering Test Notes:			

Test Measurement Results

Test Frequency MHz	Measured Output Power (dBm) Port(s)				Calculated Total Power Σ Port(s) dBm	Limit dBm	Margin dBm	EUT Power Setting
	a	b	c	d				
2412.0	27.86	--	--	--	27.86	30.00	-2.14	19.00
2437.0	27.66	--	--	--	27.66	30.00	-2.34	19.00
2462.0	27.87	--	--	--	27.87	30.00	-2.13	19.00

Traceability to Industry Recognized Test Methodologies

Work Instruction:	WI-01 MEASURING RF OUTPUT POWER
Measurement Uncertainty:	±1.33 dB

Note: [click the link in the above results matrix to view the plot](#)

This test report may be reproduced in full only. The document may only be updated by MiCOM Labs personnel. Any changes will be noted in the Document History section of the report.



Title: Spectralink 8741 Basic IP Telephone
To: FCC 47 CFR Part 15.247 & IC RSS-210
Serial #: SPEC27-U4 Rev A
Issue Date: 1st January 2014
Page: 35 of 154

Equipment Configuration for Peak Output Power

Variant:	802.11n HT-20	Duty Cycle (%):	99
Data Rate:	6.5 MBit/s	Antenna Gain (dBi):	1.20
Modulation:	OFDM	Beam Forming Gain (Y):	Not Applicable
TPC:	Not Applicable	Tested By:	CC
Engineering Test Notes:			

Test Measurement Results

Test Frequency MHz	Measured Output Power (dBm)				Calculated Total Power Σ Port(s) dBm	Limit dBm	Margin dBm	EUT Power Setting
	a	b	c	d				
2412.0	27.64	--	--	--	27.64	30.00	-2.36	19.00
2437.0	27.54	--	--	--	27.54	30.00	-2.46	19.00
2462.0	26.74	--	--	--	26.74	30.00	-3.26	18.00*

Traceability to Industry Recognized Test Methodologies

Work Instruction:	WI-01 MEASURING RF OUTPUT POWER
Measurement Uncertainty:	±1.33 dB

*Power reduction required (1 dB) in order to bring the EUT into compliance for radiated band-edge emissions, see Section 6.1.3.3

Note: [click the link in the above results matrix to view the plot](#)

This test report may be reproduced in full only. The document may only be updated by MiCOM Labs personnel. Any changes will be noted in the Document History section of the report.



Title: Spectralink 8741 Basic IP Telephone
To: FCC 47 CFR Part 15.247 & IC RSS-210
Serial #: SPEC27-U4 Rev A
Issue Date: 1st January 2014
Page: 36 of 154

Equipment Configuration for Peak Output Power

Variant:	802.11a	Duty Cycle (%):	99
Data Rate:	6 MBit/s	Antenna Gain (dBi):	4.00
Modulation:	OFDM	Beam Forming Gain (Y):	Not Applicable
TPC:	Not Applicable	Tested By:	CC
Engineering Test Notes:			

Test Measurement Results

Test Frequency MHz	Measured Output Power (dBm)				Calculated Total Power Σ Port(s) dBm	Limit dBm	Margin dBm	EUT Power Setting
	a	b	c	d				
5745.0	28.88	--	--	--	28.88	30.00	-1.12	19.00
5785.0	28.64	--	--	--	28.64	30.00	-1.36	19.00
5825.0	28.62	--	--	--	28.62	30.00	-1.38	19.00

Traceability to Industry Recognized Test Methodologies

Work Instruction:	WI-01 MEASURING RF OUTPUT POWER
Measurement Uncertainty:	±1.33 dB

Note: [click the link in the above results matrix to view the plot](#)

This test report may be reproduced in full only. The document may only be updated by MiCOM Labs personnel. Any changes will be noted in the Document History section of the report.



Title: Spectralink 8741 Basic IP Telephone
To: FCC 47 CFR Part 15.247 & IC RSS-210
Serial #: SPEC27-U4 Rev A
Issue Date: 1st January 2014
Page: 37 of 154

Equipment Configuration for Peak Output Power

Variant:	802.11n HT-20	Duty Cycle (%):	99
Data Rate:	6.5 MBit/s	Antenna Gain (dBi):	4.00
Modulation:	OFDM	Beam Forming Gain (Y):	Not Applicable
TPC:	Not Applicable	Tested By:	CC
Engineering Test Notes:			

Test Measurement Results

Test Frequency MHz	Measured Output Power (dBm)				Calculated Total Power Σ Port(s) dBm	Limit dBm	Margin dBm	EUT Power Setting
	a	b	c	d				
5745.0	28.74	--	--	--	28.74	30.00	-1.26	19.00
5785.0	28.52	--	--	--	28.52	30.00	-1.48	19.00
5825.0	28.49	--	--	--	28.49	30.00	-1.51	19.00

Traceability to Industry Recognized Test Methodologies

Work Instruction:	WI-01 MEASURING RF OUTPUT POWER
Measurement Uncertainty:	±1.33 dB

Note: [click the link in the above results matrix to view the plot](#)

This test report may be reproduced in full only. The document may only be updated by MiCOM Labs personnel. Any changes will be noted in the Document History section of the report.



Specification

Limits

§15.247 (b) The maximum peak output power of the intentional radiator shall not exceed the following:

§15.247 (b) (3) For systems using digital modulation in the 902-928 MHz, 2400-2483.5 MHz and 5725-5850 MHz bands: 1.0 watt.

15.247 (b) (4) The conducted output power limit specified in paragraph (b) of this section is based on the use of antennas with directional gains that do not exceed 6 dBi. Except as shown in paragraph (c) of this section, if transmitting antennas of directional gain greater than 6 dBi are used, the conducted output power from the intentional radiator shall be reduced below the stated values in paragraphs (b)(1), (b)(2), and (b)(3) of this section, as appropriate, by the amount in dB that the directional gain of the antenna exceeds 6 dBi.

15.247 (c) Operation with directional antenna gains greater than 6 dBi.

(1) Fixed point-to-point operation:

(i) Systems operating in the 2400–2483.5 MHz band that are used exclusively for fixed, point-to-point operations may employ transmitting antennas with directional gain greater than 6 dBi provided the maximum conducted output power of the intentional radiator is reduced by 1 dB for every 3 dB that the directional gain of the antenna exceeds 6 dBi.

(ii) Systems operating in the 5725–5850 MHz band that are used exclusively for fixed, point-to-point operations may employ transmitting antennas with directional gain greater than 6 dBi without any corresponding reduction in transmitter conducted output power.

§15.31 (e) For intentional radiators, measurements of the variation of the input power or the radiated signal level of the fundamental frequency component of the emission, as appropriate, shall be performed with the supply voltage varied between 85% and 115% of the nominal rated supply voltage. For battery operated equipment, the equipment tests shall be performed using a new battery.

§ RSS-210 A8.4(4) For systems employing digital modulation techniques operating in the 902-928 MHz, 2400-2483.5 MHz and 5725-5850 MHz bands the maximum peak conducted power shall not exceed 1 watt.

Traceability

Method	Test Equipment Used
Measurements were made per work instruction WI-01 'Measuring RF Output Power'	0158, 0287, 0252, 0313, 0314, 0070, 0116, 0117

This test report may be reproduced in full only. The document may only be updated by MiCOM Labs personnel. Any changes will be noted in the Document History section of the report.



Title: Spectralink 8741 Basic IP Telephone
To: FCC 47 CFR Part 15.247 & IC RSS-210
Serial #: SPEC27-U4 Rev A
Issue Date: 1st January 2014
Page: 39 of 154

6.1.1.3. Power Spectral Density

Conducted Test Conditions for Power Spectral Density			
Standard:	FCC CFR 47:15.247	Ambient Temp. (°C):	24.0 - 27.5
Test Heading:	Power Spectral Density	Rel. Humidity (%):	32 - 45
Standard Section(s):	15.247 (e)	Pressure (mBars):	999 - 1001
Reference Document(s):	KDB 558074 - D01 DTS Measurement Guidance v01: Section 5.3 Maximum Power Spectral Density Level in the Emission Bandwidth		

Test Procedure for Power Spectral Density

The transmitter output was connected to a spectrum analyzer and the maximum level in a 3 kHz bandwidth was measured. A peak value was found over the full emission bandwidth and the frequency span reduced to obtain enhanced resolution. Sweep time \geq span / 3 kHz with video averaging turned off. The Peak Power Spectral Density is the highest level found across the emission in a 3 kHz resolution bandwidth.

Supporting Information

Calculated Power = A + 10 log (1/x) dBm

A = Total Power Spectral Density [10 Log₁₀ (10^{a/10} + 10^{b/10} + 10^{c/10} + 10^{d/10})]

x = Duty Cycle

Limit Line: KDB 662911 was implemented for In-band power spectral density (PSD) measurements - Option (2) measure and subtract 10 log (N) dB from the limit for devices with multiple RF ports

This test report may be reproduced in full only. The document may only be updated by MiCOM Labs personnel. Any changes will be noted in the Document History section of the report.



Title: Spectralink 8741 Basic IP Telephone
To: FCC 47 CFR Part 15.247 & IC RSS-210
Serial #: SPEC27-U4 Rev A
Issue Date: 1st January 2014
Page: 40 of 154

Equipment Configuration for Power Spectral Density - Peak

Variant:	802.11b	Duty Cycle (%):	99
Data Rate:	1 MBit/s	Antenna Gain (dBi):	Not Applicable
Modulation:	CCK	Beam Forming Gain (Y):	Not Applicable
TPC:	Not Applicable	Tested By:	CC
Engineering Test Notes:			

Test Measurement Results

Test Frequency	Measured Power Spectral Density (dBm)				Calculated Total Power Spectral Density		Limit	Margin
	Port(s)				dBm			
MHz	a	b	c	d	Σ Port(s) per 30kHz RBW	Conversion to 3 kHz RBW	dBm	dB
2412.0	10.595	--	--	--	10.595	0.595	8.00	-7.40
2437.0	10.560	--	--	--	10.560	0.560	8.00	-7.44
2462.0	10.418	--	--	--	10.418	0.418	8.00	-7.58

Traceability to Industry Recognized Test Methodologies

Work Instruction:	WI-03 MEASURING RF SPECTRUM MASK
Measurement Uncertainty:	± 2.81 dB

This test report may be reproduced in full only. The document may only be updated by MiCOM Labs personnel. Any changes will be noted in the Document History section of the report.



Title: Spectralink 8741 Basic IP Telephone
To: FCC 47 CFR Part 15.247 & IC RSS-210
Serial #: SPEC27-U4 Rev A
Issue Date: 1st January 2014
Page: 41 of 154

Equipment Configuration for Power Spectral Density - Peak

Variant:	802.11g	Duty Cycle (%):	99
Data Rate:	6 MBit/s	Antenna Gain (dBi):	Not Applicable
Modulation:	OFDM	Beam Forming Gain (Y):	Not Applicable
TPC:	Not Applicable	Tested By:	CC
Engineering Test Notes:			

Test Measurement Results

Test Frequency	Measured Power Spectral Density (dBm)				Calculated Total Power Spectral Density		Limit	Margin
	Port(s)				dBm			
MHz	a	b	c	d	Σ Port(s) per 30kHz RBW	Conversion to 3 kHz RBW	dBm	dB
2412.0	5.055	--	--	--	5.055	-4.945	8.00	-12.95
2437.0	4.697	--	--	--	4.697	-5.303	8.00	-13.30
2462.0	4.512	--	--	--	4.512	-5.488	8.00	-13.49

Traceability to Industry Recognized Test Methodologies

Work Instruction:	WI-03 MEASURING RF SPECTRUM MASK
Measurement Uncertainty:	±2.81 dB

This test report may be reproduced in full only. The document may only be updated by MiCOM Labs personnel. Any changes will be noted in the Document History section of the report.



Title: Spectralink 8741 Basic IP Telephone
To: FCC 47 CFR Part 15.247 & IC RSS-210
Serial #: SPEC27-U4 Rev A
Issue Date: 1st January 2014
Page: 42 of 154

Equipment Configuration for Power Spectral Density - Peak

Variant:	802.11n HT-20	Duty Cycle (%):	99
Data Rate:	6.5 MBit/s	Antenna Gain (dBi):	Not Applicable
Modulation:	OFDM	Beam Forming Gain (Y):	Not Applicable
TPC:	Not Applicable	Tested By:	CC
Engineering Test Notes:			

Test Measurement Results

Test Frequency	Measured Power Spectral Density (dBm)				Calculated Total Power Spectral Density		Limit	Margin
	Port(s)				dBm			
MHz	a	b	c	d	Σ Port(s) per 30kHz RBW	Conversion to 3 kHz RBW	dBm	dB
2412.0	4.549	--	--	--	4.549	-5.451	8.00	-13.45
2437.0	4.612	--	--	--	4.612	-5.388	8.00	-13.39
2462.0	4.884	--	--	--	4.884	-5.116	8.00	-13.12

Traceability to Industry Recognized Test Methodologies

Work Instruction:	WI-03 MEASURING RF SPECTRUM MASK
Measurement Uncertainty:	±2.81 dB

This test report may be reproduced in full only. The document may only be updated by MiCOM Labs personnel. Any changes will be noted in the Document History section of the report.



Title: Spectralink 8741 Basic IP Telephone
To: FCC 47 CFR Part 15.247 & IC RSS-210
Serial #: SPEC27-U4 Rev A
Issue Date: 1st January 2014
Page: 43 of 154

Equipment Configuration for Power Spectral Density - Peak

Variant:	802.11a	Duty Cycle (%):	99
Data Rate:	6 MBit/s	Antenna Gain (dBi):	Not Applicable
Modulation:	OFDM	Beam Forming Gain (Y):	Not Applicable
TPC:	Not Applicable	Tested By:	CC
Engineering Test Notes:			

Test Measurement Results

Test Frequency	Measured Power Spectral Density (dBm)				Calculated Total Power Spectral Density		Limit	Margin
	Port(s)				dBm			
MHz	a	b	c	d	Σ Port(s) per 30kHz RBW	Conversion to 3 kHz RBW	dBm	dB
5745.0	5.401	--	--	--	5.401	-4.599	8.00	-12.60
5785.0	5.588	--	--	--	5.588	-4.412	8.00	-12.41
5825.0	5.480	--	--	--	5.480	-4.520	8.00	-12.52

Traceability to Industry Recognized Test Methodologies

Work Instruction:	WI-03 MEASURING RF SPECTRUM MASK
Measurement Uncertainty:	±2.81 dB

This test report may be reproduced in full only. The document may only be updated by MiCOM Labs personnel. Any changes will be noted in the Document History section of the report.



Title: Spectralink 8741 Basic IP Telephone
To: FCC 47 CFR Part 15.247 & IC RSS-210
Serial #: SPEC27-U4 Rev A
Issue Date: 1st January 2014
Page: 44 of 154

Equipment Configuration for Power Spectral Density - Peak

Variant:	802.11n HT-20	Duty Cycle (%):	99
Data Rate:	6.5 MBit/s	Antenna Gain (dBi):	Not Applicable
Modulation:	OFDM	Beam Forming Gain (Y):	Not Applicable
TPC:	Not Applicable	Tested By:	CC
Engineering Test Notes:			

Test Measurement Results

Test Frequency	Measured Power Spectral Density (dBm)				Calculated Total Power Spectral Density		Limit	Margin
	Port(s)				dBm			
MHz	a	b	c	d	Σ Port(s) per 30kHz RBW	Conversion to 3 kHz RBW	dBm	dB
5745.0	5.767	--	--	--	5.767	-4.233	8.00	-12.23
5785.0	5.143	--	--	--	5.143	-4.857	8.00	-12.86
5825.0	5.594	--	--	--	5.594	-4.406	8.00	-12.41

Traceability to Industry Recognized Test Methodologies

Work Instruction:	WI-03 MEASURING RF SPECTRUM MASK
Measurement Uncertainty:	±2.81 dB

This test report may be reproduced in full only. The document may only be updated by MiCOM Labs personnel. Any changes will be noted in the Document History section of the report.



Title: Spectralink 8741 Basic IP Telephone
To: FCC 47 CFR Part 15.247 & IC RSS-210
Serial #: SPEC27-U4 Rev A
Issue Date: 1st January 2014
Page: 45 of 154

Specification
Peak Power Spectral Density Limits

§15.247(e) For digitally modulated systems, the power spectral density conducted from the intentional radiator to the antenna shall not be greater than +8 dBm in any 3 kHz band during any time interval of continuous transmission

RSS-210 §A8.2(2) The transmitter power spectral density (into the antenna) shall not be greater than +8 dBm in any 3 kHz band during any time interval of continuous transmission or over 1.0 second if the transmission exceeds 1.0 second duration.

Traceability

Method	Test Equipment Used
Measurements were made per work instruction WI-01 'Measuring RF Output Power'	0158, 0287, 0252, 0313, 0314, 0070, 0116, 0117

This test report may be reproduced in full only. The document may only be updated by MiCOM Labs personnel. Any changes will be noted in the Document History section of the report.



Title: Spectralink 8741 Basic IP Telephone
To: FCC 47 CFR Part 15.247 & IC RSS-210
Serial #: SPEC27-U4 Rev A
Issue Date: 1st January 2014
Page: 46 of 154

6.1.1.4. Conducted Spurious Emissions

Conducted Test Conditions for Transmitter Conducted Spurious and Band-Edge Emissions			
Standard:	FCC CFR 47:15.247	Ambient Temp. (°C):	24.0 - 27.5
Test Heading:	Max Unwanted Emission Levels	Rel. Humidity (%):	32 - 45
Standard Section(s):	15.247 (d)	Pressure (mBars):	999 - 1001
Reference Document(s):	KDB 558074 - D01 DTS Measurement Guidance v01: Section 5.4 Maximum Unwanted Emission Levels		
Test Procedure for Transmitter Conducted Spurious and Band-Edge Emissions Measurement Transmitter Conducted Spurious and Band-Edge emissions were measured at a limit of 20 dB below the highest in-band spectral density measured with a spectrum analyzer connected to the antenna terminal. Measurements were made while EUT was operating in transmit mode of operation at the appropriate centre frequency closest to the band-edge. Emissions were maximized during the measurement and limits derived from the peak spectral power and drawn on each plot.			

This test report may be reproduced in full only. The document may only be updated by MiCOM Labs personnel. Any changes will be noted in the Document History section of the report.



Title: Spectralink 8741 Basic IP Telephone
To: FCC 47 CFR Part 15.247 & IC RSS-210
Serial #: SPEC27-U4 Rev A
Issue Date: 1st January 2014
Page: 47 of 154

Equipment Configuration for Transmitter Band-Edge Emissions

Variant:	802.11b	Duty Cycle (%):	99
Data Rate:	1 MBit/s	Antenna Gain (dBi):	Not Applicable
Modulation:	CCK	Beam Forming Gain (Y):	Not Applicable
TPC:	Not Applicable	Tested By:	CC
Engineering Test Notes:			

Test Measurement Results

Test Frequency	Band-Edge Frequency	Transmitter Conducted Band-Edge Emissions (dBm)							
		Port a		Port b		Port c		Port d	
MHz	MHz	BE	Limit	BE	Limit	BE	Limit	BE	Limit
2412.0	2400.0	-17.648	-5.70	--	--	--	--	--	--
2462.0	2483.5	-32.185	-4.83	--	--	--	--	--	--

Traceability to Industry Recognized Test Methodologies

Work Instruction:	WI-05 MEASUREMENT OF SPURIOUS EMISSIONS
Measurement Uncertainty:	≤40 GHz ±2.37 dB, > 40 GHz ±4.6 dB

Note: click the link in the above results matrix to view the plot

Equipment Configuration for Transmitter Conducted Spurious Emissions

Variant:	802.11b	Duty Cycle (%):	99
Data Rate:	1 MBit/s	Antenna Gain (dBi):	Not Applicable
Modulation:	CCK	Beam Forming Gain (Y):	Not Applicable
TPC:	Not Applicable	Tested By:	CC
Engineering Test Notes:			

Test Measurement Results

Test Frequency	Frequency Range	Transmitter Conducted Spurious Emissions (dBm)							
		Port a		Port b		Port c		Port d	
MHz	MHz	SE	Limit	SE	Limit	SE	Limit	SE	Limit
2412.0	30.0 - 26000.0	-54.490	-7.86	--	--	--	--	--	--
2437.0	30.0 - 26000.0	-43.609	-6.58	--	--	--	--	--	--
2462.0	30.0 - 26000.0	-40.203	-7.46	--	--	--	--	--	--

Traceability to Industry Recognized Test Methodologies

Work Instruction:	WI-05 MEASUREMENT OF SPURIOUS EMISSIONS
Measurement Uncertainty:	≤40 GHz ±2.37 dB, > 40 GHz ±4.6 dB

Note: click the link in the above results matrix to view the plot

This test report may be reproduced in full only. The document may only be updated by MiCOM Labs personnel. Any changes will be noted in the Document History section of the report.



Title: Spectralink 8741 Basic IP Telephone
To: FCC 47 CFR Part 15.247 & IC RSS-210
Serial #: SPEC27-U4 Rev A
Issue Date: 1st January 2014
Page: 48 of 154

Equipment Configuration for Transmitter Band-Edge Emissions

Variant:	802.11g	Duty Cycle (%):	99
Data Rate:	6 MBit/s	Antenna Gain (dBi):	Not Applicable
Modulation:	OFDM	Beam Forming Gain (Y):	Not Applicable
TPC:	Not Applicable	Tested By:	CC
Engineering Test Notes:			

Test Measurement Results

Test Frequency	Band-Edge Frequency	Transmitter Conducted Band-Edge Emissions (dBm)							
		Port a		Port b		Port c		Port d	
MHz	MHz	BE	Limit	BE	Limit	BE	Limit	BE	Limit
2412.0	2400.0	-17.294	-11.49	--	--	--	--	--	--
2462.0	2483.5	-29.924	-10.62	--	--	--	--	--	--

Traceability to Industry Recognized Test Methodologies

Work Instruction:	WI-05 MEASUREMENT OF SPURIOUS EMISSIONS
Measurement Uncertainty:	≤40 GHz ±2.37 dB, > 40 GHz ±4.6 dB

Note: click the link in the above results matrix to view the plot

Equipment Configuration for Transmitter Conducted Spurious Emissions

Variant:	802.11g	Duty Cycle (%):	99
Data Rate:	6 MBit/s	Antenna Gain (dBi):	Not Applicable
Modulation:	OFDM	Beam Forming Gain (Y):	Not Applicable
TPC:	Not Applicable	Tested By:	CC
Engineering Test Notes:			

Test Measurement Results

Test Frequency	Frequency Range	Transmitter Conducted Spurious Emissions (dBm)							
		Port a		Port b		Port c		Port d	
MHz	MHz	SE	Limit	SE	Limit	SE	Limit	SE	Limit
2412.0	30.0 - 26000.0	-50.312	-13.85	--	--	--	--	--	--
2437.0	30.0 - 26000.0	-44.636	-14.18	--	--	--	--	--	--
2462.0	30.0 - 26000.0	-49.070	-14.45	--	--	--	--	--	--

Traceability to Industry Recognized Test Methodologies

Work Instruction:	WI-05 MEASUREMENT OF SPURIOUS EMISSIONS
Measurement Uncertainty:	=40 GHz ±2.37 dB, > 40 GHz ±4.6 dB

Note: click the link in the above results matrix to view the plot

This test report may be reproduced in full only. The document may only be updated by MiCOM Labs personnel. Any changes will be noted in the Document History section of the report.



Title: Spectralink 8741 Basic IP Telephone
To: FCC 47 CFR Part 15.247 & IC RSS-210
Serial #: SPEC27-U4 Rev A
Issue Date: 1st January 2014
Page: 49 of 154

Equipment Configuration for Transmitter Band-Edge Emissions

Variant:	802.11n HT-20	Duty Cycle (%):	99
Data Rate:	6.5 MBit/s	Antenna Gain (dBi):	Not Applicable
Modulation:	OFDM	Beam Forming Gain (Y):	Not Applicable
TPC:	Not Applicable	Tested By:	CC
Engineering Test Notes:			

Test Measurement Results

Test Frequency	Band-Edge Frequency	Transmitter Conducted Band-Edge Emissions (dBm)							
		Port a		Port b		Port c		Port d	
MHz	MHz	BE	Limit	BE	Limit	BE	Limit	BE	Limit
2412.0	2400.0	-15.126	-10.34	--	--	--	--	--	--
2462.0	2483.5	-29.110	-10.19	--	--	--	--	--	--

Traceability to Industry Recognized Test Methodologies

Work Instruction:	WI-05 MEASUREMENT OF SPURIOUS EMISSIONS
Measurement Uncertainty:	≤40 GHz ±2.37 dB, > 40 GHz ±4.6 dB

Note: click the link in the above results matrix to view the plot

Equipment Configuration for Transmitter Conducted Spurious Emissions

Variant:	802.11n HT-20	Duty Cycle (%):	99
Data Rate:	6.5 MBit/s	Antenna Gain (dBi):	Not Applicable
Modulation:	OFDM	Beam Forming Gain (Y):	Not Applicable
TPC:	Not Applicable	Tested By:	CC
Engineering Test Notes:			

Test Measurement Results

Test Frequency	Frequency Range	Transmitter Conducted Spurious Emissions (dBm)							
		Port a		Port b		Port c		Port d	
MHz	MHz	SE	Limit	SE	Limit	SE	Limit	SE	Limit
2412.0	30.0 - 26000.0	-49.682	-14.62	--	--	--	--	--	--
2437.0	30.0 - 26000.0	-44.921	-14.86	--	--	--	--	--	--
2462.0	30.0 - 26000.0	-51.669	-15.14	--	--	--	--	--	--

Traceability to Industry Recognized Test Methodologies

Work Instruction:	WI-05 MEASUREMENT OF SPURIOUS EMISSIONS
Measurement Uncertainty:	=40 GHz ±2.37 dB, > 40 GHz ±4.6 dB

Note: click the link in the above results matrix to view the plot

This test report may be reproduced in full only. The document may only be updated by MiCOM Labs personnel. Any changes will be noted in the Document History section of the report.



Title: Spectralink 8741 Basic IP Telephone
To: FCC 47 CFR Part 15.247 & IC RSS-210
Serial #: SPEC27-U4 Rev A
Issue Date: 1st January 2014
Page: 50 of 154

Equipment Configuration for Transmitter Band-Edge Emissions

Variant:	802.11a	Duty Cycle (%):	99
Data Rate:	6 MBit/s	Antenna Gain (dBi):	Not Applicable
Modulation:	OFDM	Beam Forming Gain (Y):	Not Applicable
TPC:	Not Applicable	Tested By:	CC
Engineering Test Notes:			

Test Measurement Results

Test Frequency	Band-Edge Frequency	Transmitter Conducted Band-Edge Emissions (dBm)							
		Port a		Port b		Port c		Port d	
MHz	MHz	BE	Limit	BE	Limit	BE	Limit	BE	Limit
5745.0	5725.0	-18.203	-9.34	--	--	--	--	--	--
5825.0	5850.0	-26.435	-9.65	--	--	--	--	--	--

Traceability to Industry Recognized Test Methodologies

Work Instruction:	WI-05 MEASUREMENT OF SPURIOUS EMISSIONS
Measurement Uncertainty:	≤40 GHz ±2.37 dB, > 40 GHz ±4.6 dB

Note: click the link in the above results matrix to view the plot

Equipment Configuration for Transmitter Conducted Spurious Emissions

Variant:	802.11a	Duty Cycle (%):	99
Data Rate:	6 MBit/s	Antenna Gain (dBi):	Not Applicable
Modulation:	OFDM	Beam Forming Gain (Y):	Not Applicable
TPC:	Not Applicable	Tested By:	CC
Engineering Test Notes:			

Test Measurement Results

Test Frequency	Frequency Range	Transmitter Conducted Spurious Emissions (dBm)							
		Port a		Port b		Port c		Port d	
MHz	MHz	SE	Limit	SE	Limit	SE	Limit	SE	Limit
5745.0	30.0 - 26000.0	-49.565	-14.01	--	--	--	--	--	--
5785.0	30.0 - 26000.0	-39.738	-14.78	--	--	--	--	--	--
5825.0	30.0 - 26000.0	-40.212	-15.12	--	--	--	--	--	--

Traceability to Industry Recognized Test Methodologies

Work Instruction:	WI-05 MEASUREMENT OF SPURIOUS EMISSIONS
Measurement Uncertainty:	=40 GHz ±2.37 dB, > 40 GHz ±4.6 dB

Note: click the link in the above results matrix to view the plot

This test report may be reproduced in full only. The document may only be updated by MiCOM Labs personnel. Any changes will be noted in the Document History section of the report.



Title: Spectralink 8741 Basic IP Telephone
To: FCC 47 CFR Part 15.247 & IC RSS-210
Serial #: SPEC27-U4 Rev A
Issue Date: 1st January 2014
Page: 51 of 154

Equipment Configuration for Transmitter Band-Edge Emissions

Variant:	802.11n HT-20	Duty Cycle (%):	99
Data Rate:	6.5 MBit/s	Antenna Gain (dBi):	Not Applicable
Modulation:	OFDM	Beam Forming Gain (Y):	Not Applicable
TPC:	Not Applicable	Tested By:	CC
Engineering Test Notes:			

Test Measurement Results

Test Frequency	Band-Edge Frequency	Transmitter Conducted Band-Edge Emissions (dBm)							
		Port a		Port b		Port c		Port d	
MHz	MHz	BE	Limit	BE	Limit	BE	Limit	BE	Limit
5745.0	5725.0	-16.163	-9.69	--	--	--	--	--	--
5825.0	5850.0	-26.764	-9.19	--	--	--	--	--	--

Traceability to Industry Recognized Test Methodologies

Work Instruction:	WI-05 MEASUREMENT OF SPURIOUS EMISSIONS
Measurement Uncertainty:	≤40 GHz ±2.37 dB, > 40 GHz ±4.6 dB

Note: [click the link in the above results matrix to view the plot](#)

Equipment Configuration for Transmitter Conducted Spurious Emissions

Variant:	802.11n HT-20	Duty Cycle (%):	99
Data Rate:	6.5 MBit/s	Antenna Gain (dBi):	Not Applicable
Modulation:	OFDM	Beam Forming Gain (Y):	Not Applicable
TPC:	Not Applicable	Tested By:	CC
Engineering Test Notes:			

Test Measurement Results

Test Frequency	Frequency Range	Transmitter Conducted Spurious Emissions (dBm)							
		Port a		Port b		Port c		Port d	
MHz	MHz	SE	Limit	SE	Limit	SE	Limit	SE	Limit
5745.0	30.0 - 26000.0	-49.140	-14.99	--	--	--	--	--	--
5785.0	30.0 - 26000.0	-40.084	-11.59	--	--	--	--	--	--
5825.0	30.0 - 26000.0	-39.476	-15.31	--	--	--	--	--	--

Traceability to Industry Recognized Test Methodologies

Work Instruction:	WI-05 MEASUREMENT OF SPURIOUS EMISSIONS
Measurement Uncertainty:	=40 GHz ±2.37 dB, > 40 GHz ±4.6 dB

Note: [click the link in the above results matrix to view the plot](#)

This test report may be reproduced in full only. The document may only be updated by MiCOM Labs personnel. Any changes will be noted in the Document History section of the report.



Specification

Limits Band-Edge

Lower Limit Band-edge	Upper Limit Band-edge	Limit below highest level of desired power
2,400 MHz	2,483.5 MHz	≥ 20 dB
5725 MHz	5850 MHz	

§15.247(d) and RSS-210 §A8.5 In any 100 kHz bandwidth outside the frequency band in which the spread spectrum or digitally modulated intentional radiator is operating, the radio frequency power that is produced by the intentional radiator shall be at least 20 dB below that in the 100 kHz bandwidth within the band that contains the highest level of the desired power, based on either an RF conducted or radiated measurement, provided the transmitter demonstrates compliance with the peak conducted power limits.

§15.247(d)

If the transmitter complies with the conducted power limits based on the use of RMS averaging over a time interval, as permitted under paragraph (b)(3) of this section, the attenuation required under this paragraph shall be 30 dB instead of 20 dB. Attenuation below the general limits specified §15.209(a) is not required. In addition, radiated emissions which fall in the restricted bands, as defined in Section §15.205(a), must also comply with the radiated emission limits specified in Section 15.209(a) (see Section 15.205(a)).

Laboratory Measurement Uncertainty for Conducted Spurious Emissions

Measurement uncertainty	±2.37 dB
-------------------------	----------

Traceability

Method	Test Equipment Used
Measurements were made per work instruction WI-05 'Measurement of Spurious Emissions'	0088, 0158, 0287, 0252, 0313, 0314, 0070, 0116, 0117.



6.1.1.5. Maximum Permissible Exposure

FCC, Part 15 Subpart C §15.247(i)
Industry Canada RSS-Gen §5.6

Calculations for Maximum Permissible Exposure Levels

$$\text{Power Density} = P_d \text{ (mW/cm}^2\text{)} = \text{EIRP}/(4\pi d^2)$$

$$\text{EIRP} = P * G$$

P = Peak output power (mW)

G = Antenna numeric gain (numeric)

d = Separation distance (cm)

$$\text{Numeric Gain} = 10^{(G \text{ (dBi)}/10)}$$

Because the EUT belongs to the General Population/Uncontrolled Exposure the limit of power density is 1.0 mW/cm²

Antenna	Freq. Band (GHz)	Antenna Gain (dBi)	Numeric Gain (numeric)	Peak Output Power (dBm)	Peak Output Power (mW)	Calculated Safe Distance @ 1mW/cm ² Limit(cm)	Minimum Separation Distance (cm)
PCB	2.4	+1.2	1.32	27.87	612.4	8.02	20
PCB	5.8	+4.0	2.51	28.88	772.7	12.4	20

Specification

Maximum Permissible Exposure Limits

§15.247(i) Systems operating under the provisions of this section shall be operated in a manner that ensures that the public is not exposed to radio frequency levels in excess of the Commission's guidelines.

FCC §1.1310 Limit = 1mW / cm² from 1.310 Table 1

RSS-Gen §5.6 Category I and Category II equipment shall comply with the applicable requirements of RSS-102.

Laboratory Measurement Uncertainty for Power Measurements

Measurement uncertainty	±1.33 dB
-------------------------	----------

This test report may be reproduced in full only. The document may only be updated by MiCOM Labs personnel. Any changes will be noted in the Document History section of the report.



6.1.2. Radiated Emission Testing

6.1.2.1. Spurious Emissions (above 1 GHz)

Transmitter Radiated Spurious Emissions (above 1 GHz); Peak Field Strength Measurements; and Radiated Band Edge Measurements – Restricted Bands

FCC, Part 15 Subpart C §15.247(d) 15.205; 15.209

Industry Canada RSS-210 §A8.5, §2.2, §2.6

Industry Canada RSS-Gen §4.7

Test Procedure

The worst case highest spectral density radiated emissions above 1 GHz are measured in the anechoic chamber at a 3-meter distance on every azimuth in both horizontal and vertical polarities. The emissions are recorded and maximized as a function of azimuth by rotation through 360° with a spectrum analyzer in peak hold mode. Depending on the frequency band spanned a notch filter and waveguide filter was used to remove the fundamental frequency. The highest emissions relative to the limit are listed for each frequency spanned.

All measurements on any frequency or frequencies over 1 MHz are based on the use of measurement instrumentation employing an average detector function. All measurements above 1 GHz were performed using a minimum resolution bandwidth of 1 MHz.

Field Strength Calculation

The field strength is calculated by adding the Antenna Factor and Cable Loss, and subtracting Amplifier Gain from the measured reading. All factors are included in the reported data.

$$FS = R + AF + CORR - FO$$

where: FS = Field Strength

R = Measured Spectrum analyzer Input Amplitude

AF = Antenna Factor

CORR = Correction Factor = CL – AG + NFL

CL = Cable Loss

AG = Amplifier Gain

FO = Distance Falloff Factor

NFL = Notch Filter Loss or Waveguide Loss

For example:

Given receiver input reading of 51.5 dB μ V; Antenna Factor of 8.5 dB; Cable Loss of 1.3 dB; Falloff Factor of 0 dB, an Amplifier Gain of 26 dB and Notch Filter Loss of 1 dB. The Field Strength of the measured emission is:

$$FS = 51.5 + 8.5 + 1.3 - 26.0 + 1 = 36.3 \text{ dB}\mu\text{V/m}$$

Conversion between dB μ V/m (or dB μ V) and μ V/m (or μ V) are done as:

$$\text{Level (dB}\mu\text{V/m)} = 20 * \text{Log (level (\mu\text{V/m}))}$$

$$40 \text{ dB}\mu\text{V/m} = 100 \mu\text{V/m}$$

$$48 \text{ dB}\mu\text{V/m} = 250 \mu\text{V/m}$$

This test report may be reproduced in full only. The document may only be updated by MiCOM Labs personnel. Any changes will be noted in the Document History section of the report.



Test Freq.	2412 MHz	Engineer	SB
Variant	802.11b; 1 Mbit/s	Temp (°C)	22
Freq. Range	1000 MHz - 18000 MHz	Rel. Hum.(%)	44
Power Setting	Max	Press. (mBars)	1005
Antenna	Integral	Duty Cycle (%)	100
Test Notes 1			
Test Notes 2			

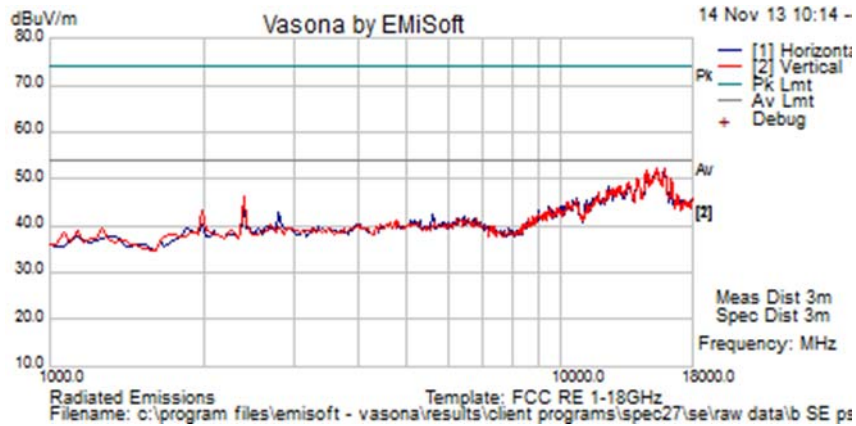

Formally measured emission peaks

Frequency MHz	Raw dBuV	Cable Loss	AF dB	Level dBuV/m	Measurement Type	Pol	Hgt cm	Azt Deg	Limit dBuV/m	Margin dB	Pass /Fail	Comments
2400.753	52.7	3.0	-11.6	44.0	Peak [Scan]	V						FUND

Legend: TX = Transmitter Emissions; DIG = Digital Emissions; FUND = Fundamental; WB = Wideband Emission
 NRB = Non-Restricted Band. Limit = 68.23 dBuV/m; RB = Restricted Band. Limits per 15.205



Title: Spectralink 8741 Basic IP Telephone
To: FCC 47 CFR Part 15.247 & IC RSS-210
Serial #: SPEC27-U4 Rev A
Issue Date: 1st January 2014
Page: 56 of 154

Test Freq.	2437 MHz	Engineer	JMH
Variant	802.11b; 1 Mbit/s	Temp (°C)	25
Freq. Range	1000 MHz - 18000 MHz	Rel. Hum.(%)	32
Power Setting	Max	Press. (mBars)	1002
Antenna	Integral	Duty Cycle (%)	100
Test Notes 1			
Test Notes 2			

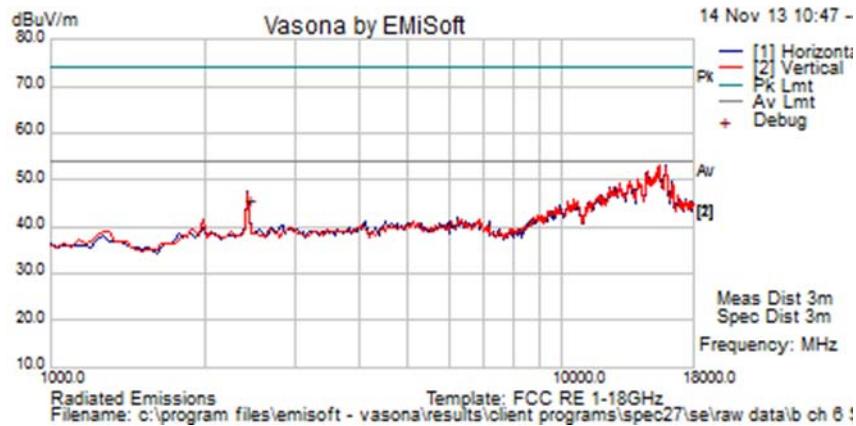

Formally measured emission peaks

Frequency MHz	Raw dBuV	Cable Loss	AF dB	Level dBuV/m	Measurement Type	Pol	Hgt cm	Azt Deg	Limit dBuV/m	Margin dB	Pass /Fail	Comments
2431.910	56.0	3.0	-11.6	47.5	Peak [Scan]	V						FUND
Legend:	TX = Transmitter Emissions; DIG = Digital Emissions; FUND = Fundamental; WB = Wideband Emission											
	NRB = Non-Restricted Band. Limit = 68.23 dBuV/m; RB = Restricted Band. Limits per 15.205											

This test report may be reproduced in full only. The document may only be updated by MiCOM Labs personnel. Any changes will be noted in the Document History section of the report.



Test Freq.	2462 MHz	Engineer	JMH
Variant	802.11b; 1 Mbit/s	Temp (°C)	22
Freq. Range	1000 MHz - 18000 MHz	Rel. Hum.(%)	23
Power Setting	Max	Press. (mBars)	1002
Antenna	Integral	Duty Cycle (%)	100
Test Notes 1			
Test Notes 2			

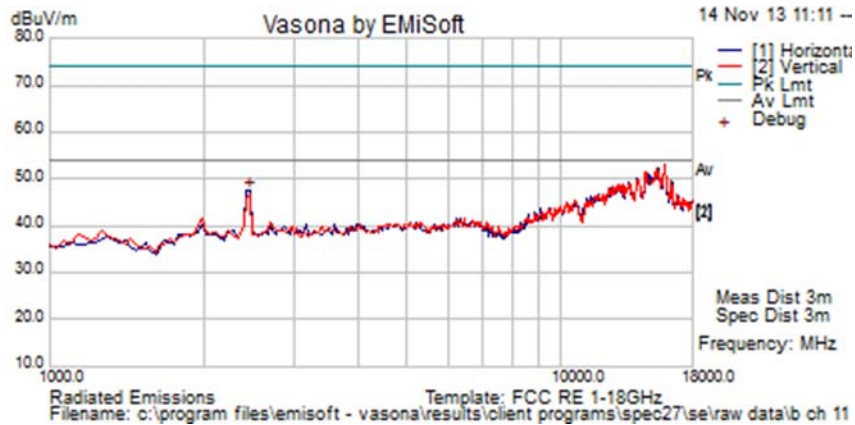

Formally measured emission peaks

Frequency MHz	Raw dBuV	Cable Loss	AF dB	Level dBuV/m	Measurement Type	Pol	Hgt cm	Azt Deg	Limit dBuV/m	Margin dB	Pass /Fail	Comments
2446.337	56.1	3.0	-11.5	47.5	Peak [Scan]	V						FUND
Legend: TX = Transmitter Emissions; DIG = Digital Emissions; FUND = Fundamental; WB = Wideband Emission NRB = Non-Restricted Band. Limit = 68.23 dBuV/m; RB = Restricted Band. Limits per 15.205												

This test report may be reproduced in full only. The document may only be updated by MiCOM Labs personnel. Any changes will be noted in the Document History section of the report.



Title: Spectralink 8741 Basic IP Telephone
To: FCC 47 CFR Part 15.247 & IC RSS-210
Serial #: SPEC27-U4 Rev A
Issue Date: 1st January 2014
Page: 58 of 154

Test Freq.	5745 MHz	Engineer	SB
Variant	802.11a; 6 Mbit/s	Temp (°C)	22
Freq. Range	1000 MHz - 18000 MHz	Rel. Hum.(%)	44
Power Setting	Max	Press. (mBars)	1005
Antenna	Integral	Duty Cycle (%)	100
Test Notes 1			
Test Notes 2			

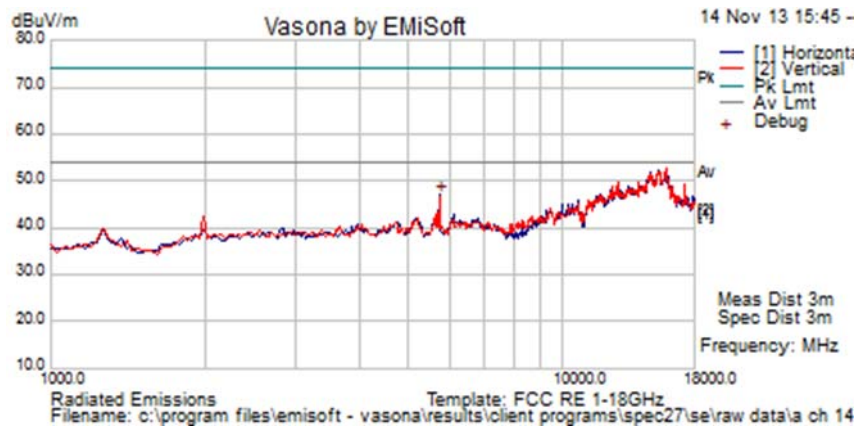

Formally measured emission peaks

Frequency MHz	Raw dBuV	Cable Loss	AF dB	Level dBuV/m	Measurement Type	Pol	Hgt cm	Azt Deg	Limit dBuV/m	Margin dB	Pass /Fail	Comments
5736.670	51.6	4.8	-9.5	46.8	Peak [Scan]	V						FUND
Legend: TX = Transmitter Emissions; DIG = Digital Emissions; FUND = Fundamental; WB = Wideband Emission NRB = Non-Restricted Band. Limit = 68.23 dBuV/m; RB = Restricted Band. Limits per 15.205												

This test report may be reproduced in full only. The document may only be updated by MiCOM Labs personnel. Any changes will be noted in the Document History section of the report.



Title: Spectralink 8741 Basic IP Telephone
To: FCC 47 CFR Part 15.247 & IC RSS-210
Serial #: SPEC27-U4 Rev A
Issue Date: 1st January 2014
Page: 59 of 154

Test Freq.	5785 MHz	Engineer	SB
Variant	802.11a; 6 Mbit/s	Temp (°C)	22
Freq. Range	1000 MHz - 18000 MHz	Rel. Hum.(%)	44
Power Setting	Max	Press. (mBars)	1005
Antenna	Integral	Duty Cycle (%)	100
Test Notes 1			
Test Notes 2			

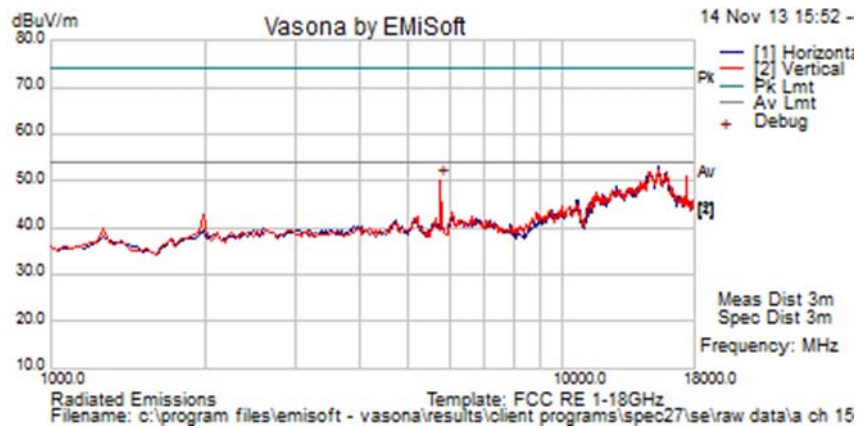

Formally measured emission peaks

Frequency MHz	Raw dBuV	Cable Loss	AF dB	Level dBuV/m	Measurement Type	Pol	Hgt cm	Azt Deg	Limit dBuV/m	Margin dB	Pass /Fail	Comments
5769.539	54.9	4.8	-9.5	50.2	Peak [Scan]	V						FUND
Legend: TX = Transmitter Emissions; DIG = Digital Emissions; FUND = Fundamental; WB = Wideband Emission NRB = Non-Restricted Band. Limit = 68.23 dBuV/m; RB = Restricted Band. Limits per 15.205												

This test report may be reproduced in full only. The document may only be updated by MiCOM Labs personnel. Any changes will be noted in the Document History section of the report.



Title: Spectralink 8741 Basic IP Telephone
To: FCC 47 CFR Part 15.247 & IC RSS-210
Serial #: SPEC27-U4 Rev A
Issue Date: 1st January 2014
Page: 60 of 154

Test Freq.	5825 MHz	Engineer	SB
Variant	802.11a; 6 Mbit/s	Temp (°C)	22
Freq. Range	1000 MHz - 18000 MHz	Rel. Hum.(%)	44
Power Setting	Max	Press. (mBars)	1005
Antenna	Integral	Duty Cycle (%)	100
Test Notes 1			
Test Notes 2			

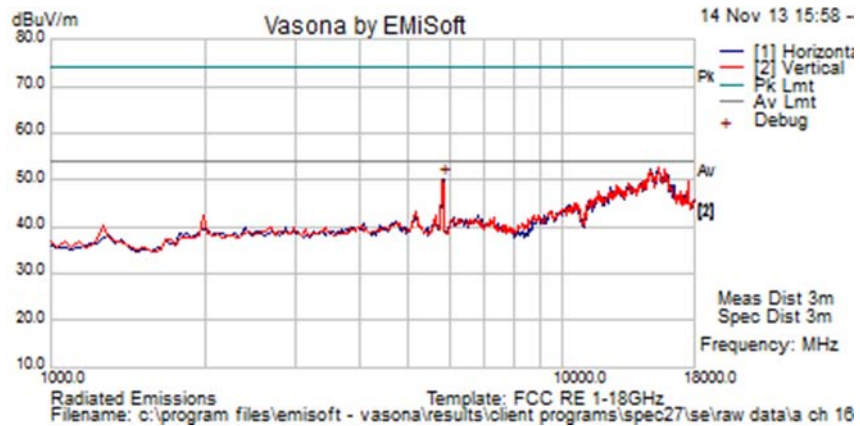

Formally measured emission peaks

Frequency MHz	Raw dBuV	Cable Loss	AF dB	Level dBuV/m	Measurement Type	Pol	Hgt cm	Azt Deg	Limit dBuV/m	Margin dB	Pass /Fail	Comments
5837.675	54.8	4.8	-9.3	50.3	Peak [Scan]	H						FUND
Legend: TX = Transmitter Emissions; DIG = Digital Emissions; FUND = Fundamental; WB = Wideband Emission NRB = Non-Restricted Band. Limit = 68.23 dBuV/m; RB = Restricted Band. Limits per 15.205												

This test report may be reproduced in full only. The document may only be updated by MiCOM Labs personnel. Any changes will be noted in the Document History section of the report.



Specification Limits

FCC §15.247(d) and RSS-210 §A8.5 In any 100 kHz bandwidth outside the frequency band in which the spread spectrum or digitally modulated intentional radiator is operating, the radio frequency power that is produced by the intentional radiator shall be at least 20 dB below that in the 100 kHz bandwidth within the band that contains the highest level of the desired power, based on either an RF conducted or radiated measurement, provided the transmitter demonstrates compliance with the peak conducted power limits.

FCC §15.247(d)

If the transmitter complies with the conducted power limits based on the use of RMS averaging over a time interval, as permitted under paragraph (b)(3) of this section, the attenuation required under this paragraph shall be 30 dB instead of 20 dB. Attenuation below the general limits specified §15.209(a) is not required. In addition, radiated emissions which fall in the restricted bands, as defined in Section §15.205(a), must also comply with the radiated emission limits specified in Section 15.209(a) (see Section 15.205(a)).

IC RSS-210 §A8.5 If the transmitter complies with the conducted power limits based on the use of RMS averaging over a time interval, as permitted under section A8.4(4), the attenuation required shall be 30 dB instead of 20 dB. Attenuation below the general limits specified in Tables 2 and 3 is not required. In addition, radiated emissions which fall in the restricted bands of Table 1 must also comply with the radiated emission limits specified in Tables 2 and 3.

FCC §15.205 (a) Except as shown in paragraph (d) of 15.205 (a), only spurious emissions are permitted in any of the frequency bands listed.

FCC §15.205 (a) Except as shown in paragraphs (d) and (e) of this section, the field strength of emissions appearing within these frequency bands shall not exceed the limits shown in Section §15.209. At frequencies equal to or less than 1000 MHz, compliance with the limits in Section 15.209 shall be demonstrated using measurement instrumentation employing a CISPR quasi-peak detector. Above 1000 MHz, compliance with the emission limits in Section 15.209 shall be demonstrated based on the average value of the measured emissions. The provisions in Section 15.35 apply to these measurements.

FCC §15.209 (a) Except as provided elsewhere in this subpart, the emissions from an intentional radiator shall not exceed the field strength levels specified in the following table.



Title: Spectralink 8741 Basic IP Telephone
To: FCC 47 CFR Part 15.247 & IC RSS-210
Serial #: SPEC27-U4 Rev A
Issue Date: 1st January 2014
Page: 62 of 154

§15.209 (a) Limit Matrix

Frequency(MHz)	Field Strength ($\mu\text{V/m}$)	Field Strength ($\text{dB}\mu\text{V/m}$)	Measurement Distance (meters)
30-88	100	40.0	3
88-216	150	43.5	3
216-960	200	46.0	3
Above 960	500	54.0	3

Laboratory Measurement Uncertainty for Radiated Emissions

Measurement uncertainty	+5.6/ -4.5 dB
-------------------------	---------------

Traceability

Method	Test Equipment Used
Measurements were made per work instruction WI-03 'Measurement of Radiated Emissions'	0088, 0158, 0134, 0304, 0311, 0315, 0310, 0312

This test report may be reproduced in full only. The document may only be updated by MiCOM Labs personnel. Any changes will be noted in the Document History section of the report.



6.1.2.2. Restricted Band-Edge

2.4 GHz Frequency Band

Peak Limit 74.0 dB μ V, Peak Limit 54.0 dB μ V

Integral Antenna

Operational Mode	Band-Edge 2390 MHz			Band-Edge 2483.5 MHz		
	dB μ V		Power Setting	dB μ V		Power Setting
	Peak	Average		Peak	Average	
b	51.62	44.76	22	56.33	49.95	22
g	68.94	51.21	19	69.42	47.68	19
n HT-20	73.25	53.23	19	72.80	49.54	18*

*Power reduction required (1 dB) in order to bring the EUT into compliance

5.725 – 5.850 GHz Frequency Band – Restricted Band-edge @ 5460 MHz

Peak Limit 74.0 dB μ V, Peak Limit 54.0 dB μ V

Integral Antenna

Operational Mode	5460 MHz		
	dB μ V		Power Setting
	Peak	Average	
a	50.26	33.50	19
n HT-20	48.66	33.76	19



Radiated Restricted Band-Edge

2390 MHz: 802.11b 2412 MHz

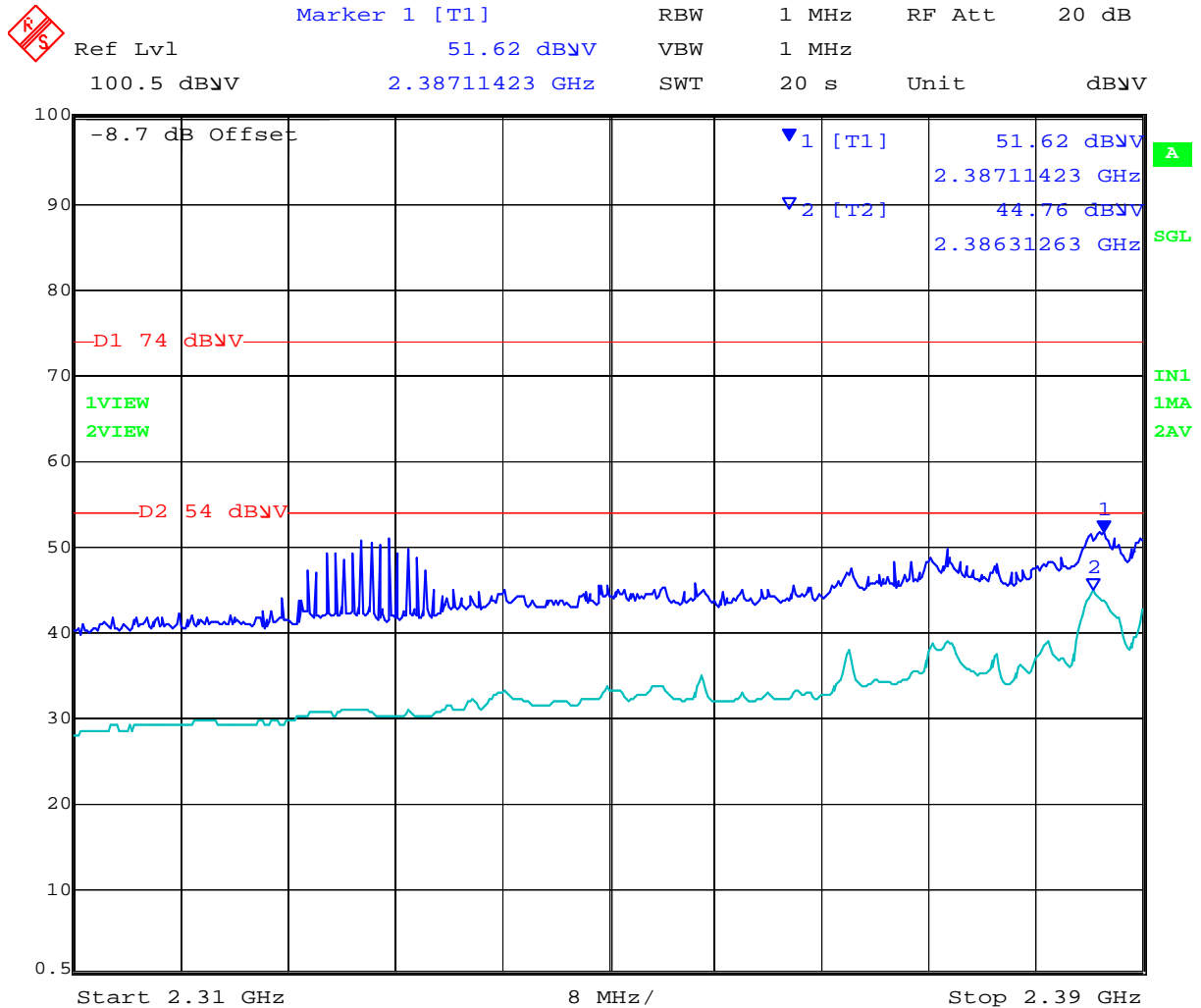

Date: 8.NOV.2013 11:03:57

This test report may be reproduced in full only. The document may only be updated by MiCOM Labs personnel. Any changes will be noted in the Document History section of the report.



Radiated Restricted Band-Edge

2483.5 MHz: 802.11b 2462 MHz



Date: 8.NOV.2013 15:00:27

This test report may be reproduced in full only. The document may only be updated by MiCOM Labs personnel. Any changes will be noted in the Document History section of the report.



Radiated Restricted Band-Edge

2390 MHz: 802.11g 2412 MHz

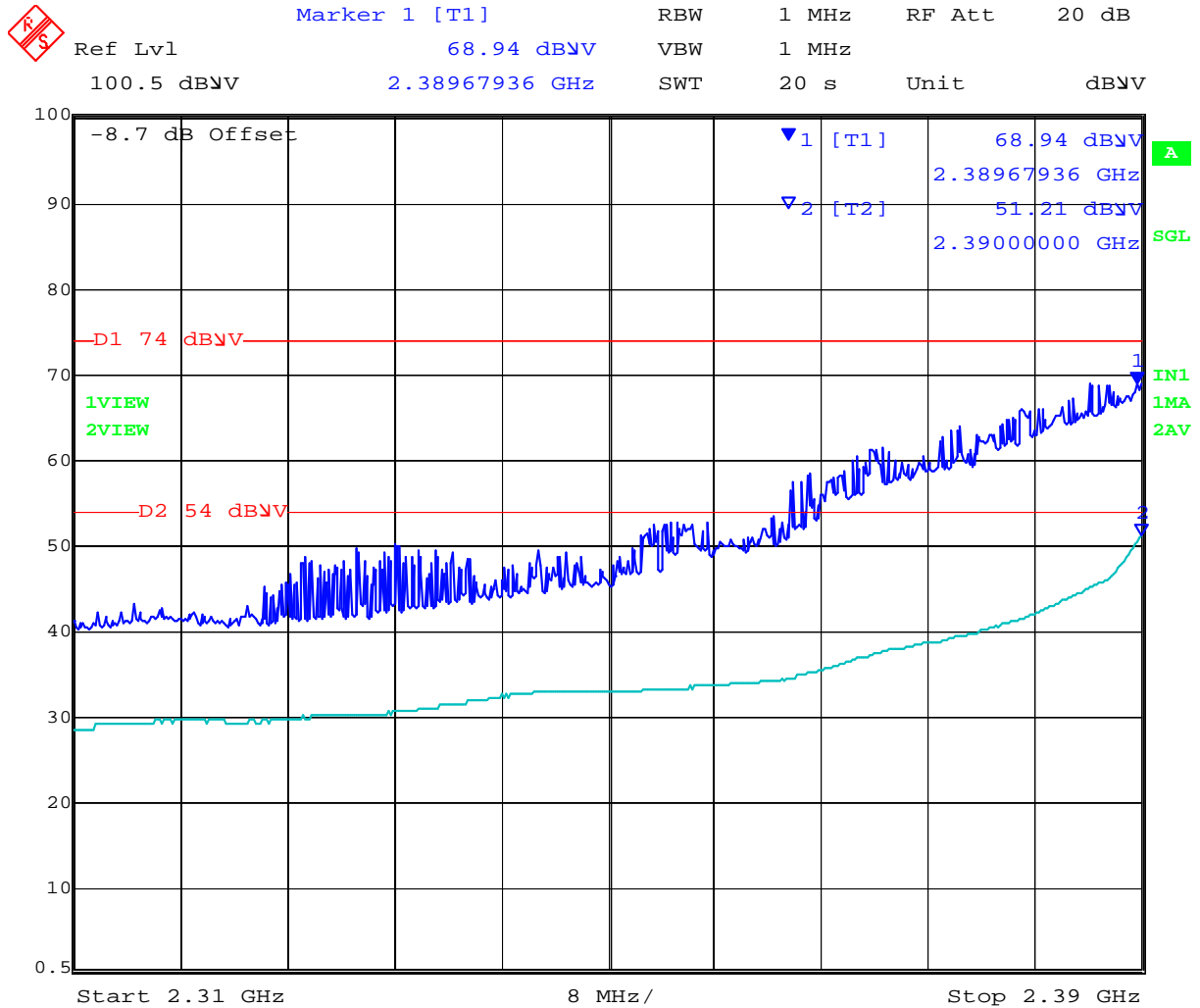

Date: 8.NOV.2013 11:16:32

This test report may be reproduced in full only. The document may only be updated by MiCOM Labs personnel. Any changes will be noted in the Document History section of the report.



Radiated Restricted Band-Edge

2483.5 MHz: 802.11g 2462 MHz

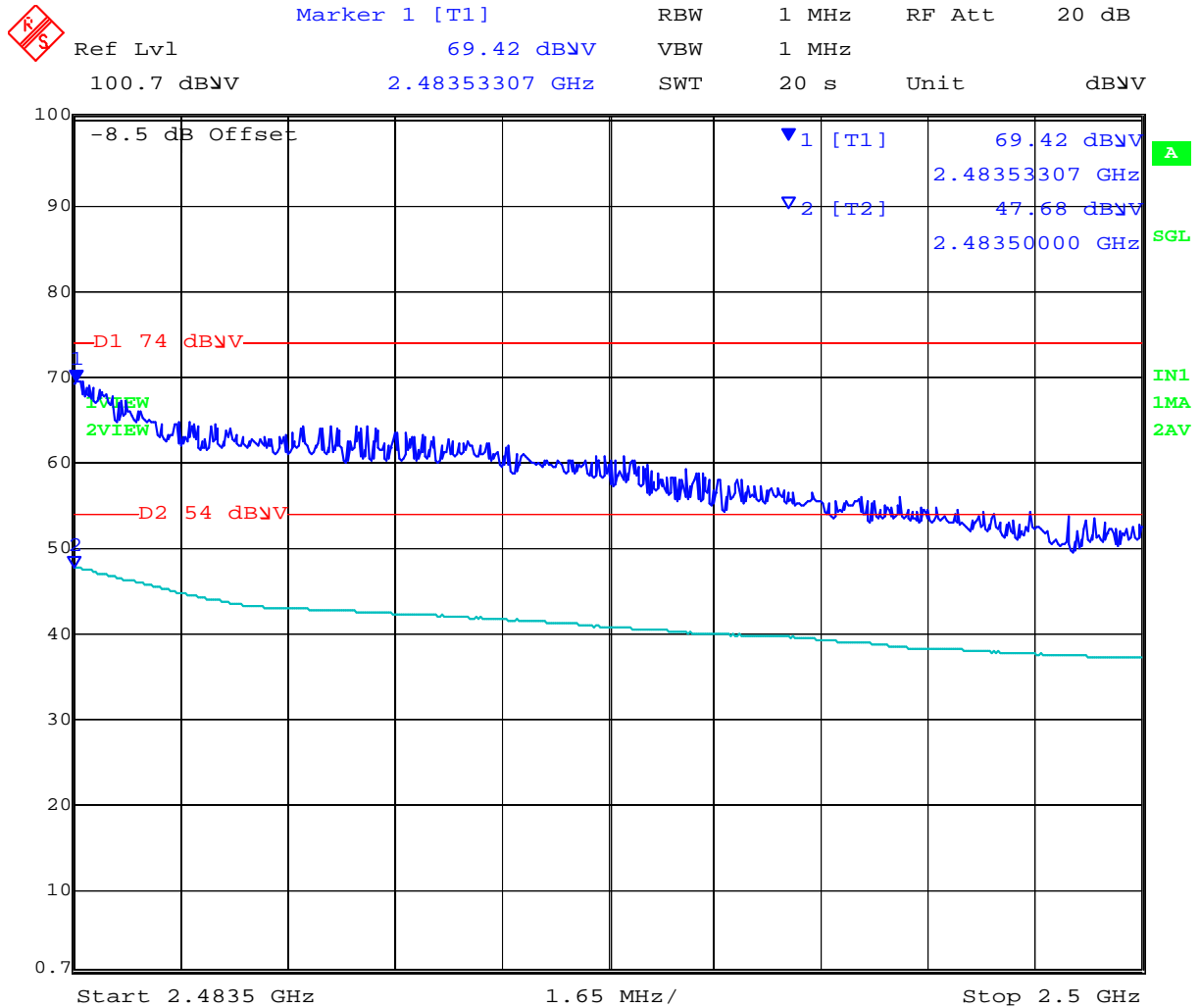

Date: 8.NOV.2013 14:48:56

This test report may be reproduced in full only. The document may only be updated by MiCOM Labs personnel. Any changes will be noted in the Document History section of the report.



Radiated Restricted Band-Edge

2390 MHz: 802.11n HT-20 2412 MHz

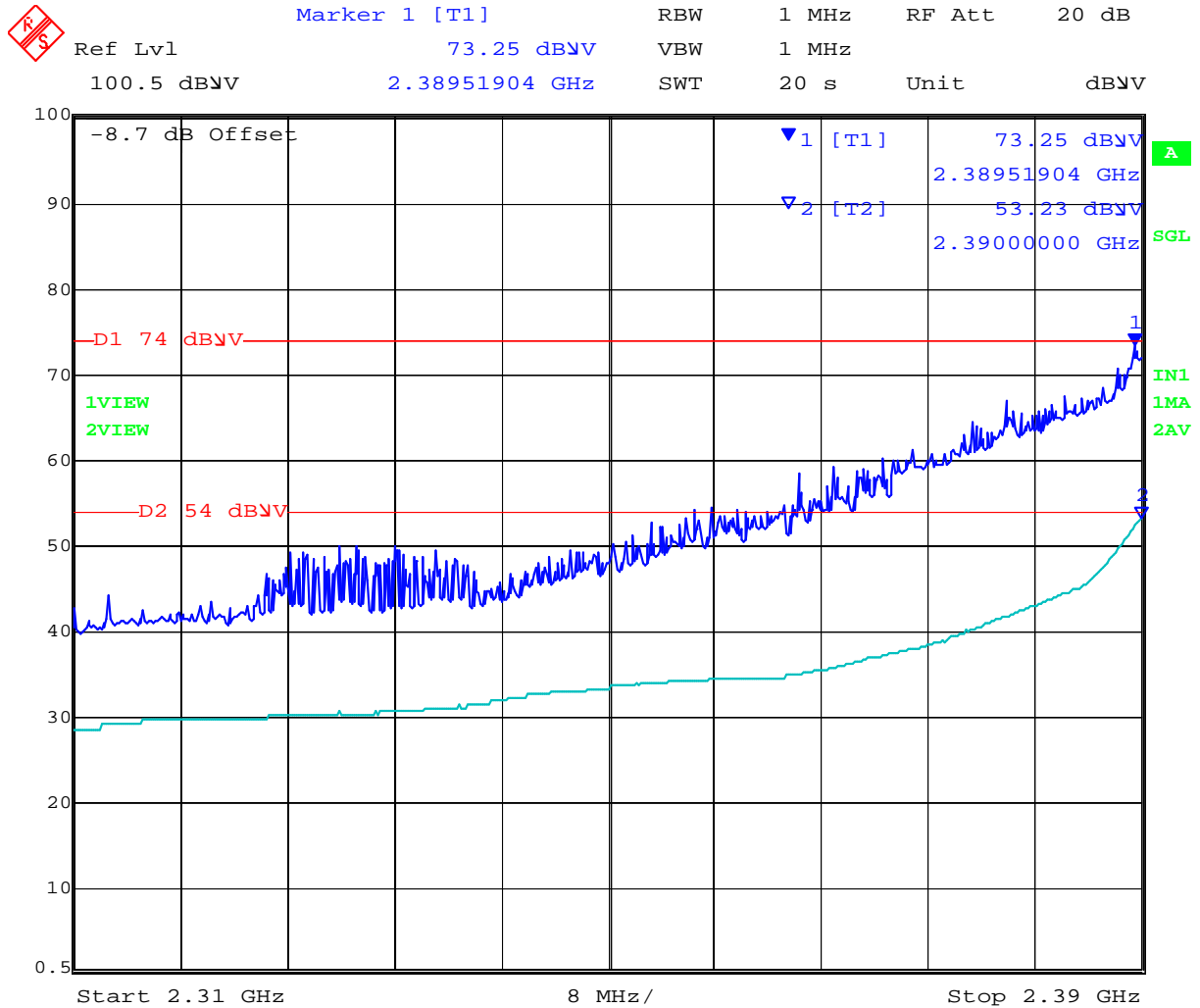

Date: 8.NOV.2013 11:19:55

This test report may be reproduced in full only. The document may only be updated by MiCOM Labs personnel. Any changes will be noted in the Document History section of the report.



Radiated Restricted Band-Edge

2483.5 MHz: 802.11n HT-20 2462 MHz

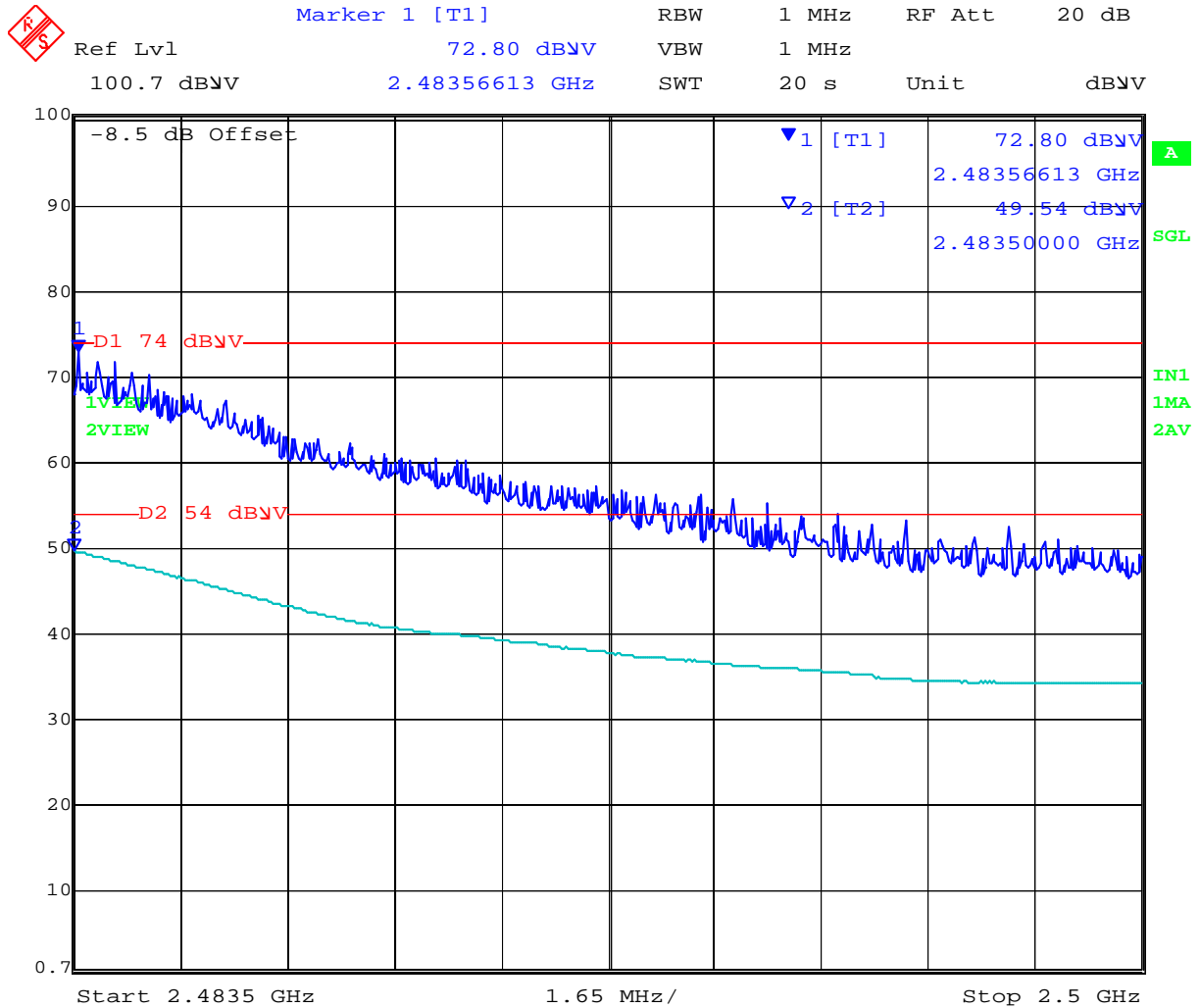

Date: 8.NOV.2013 14:22:16

*Power reduction required (1 dB) in order to bring the EUT into compliance for radiated band-edge emissions,

This test report may be reproduced in full only. The document may only be updated by MiCOM Labs personnel. Any changes will be noted in the Document History section of the report.



Radiated Restricted Band-Edge

5460 MHz: 802.11a 5745 MHz

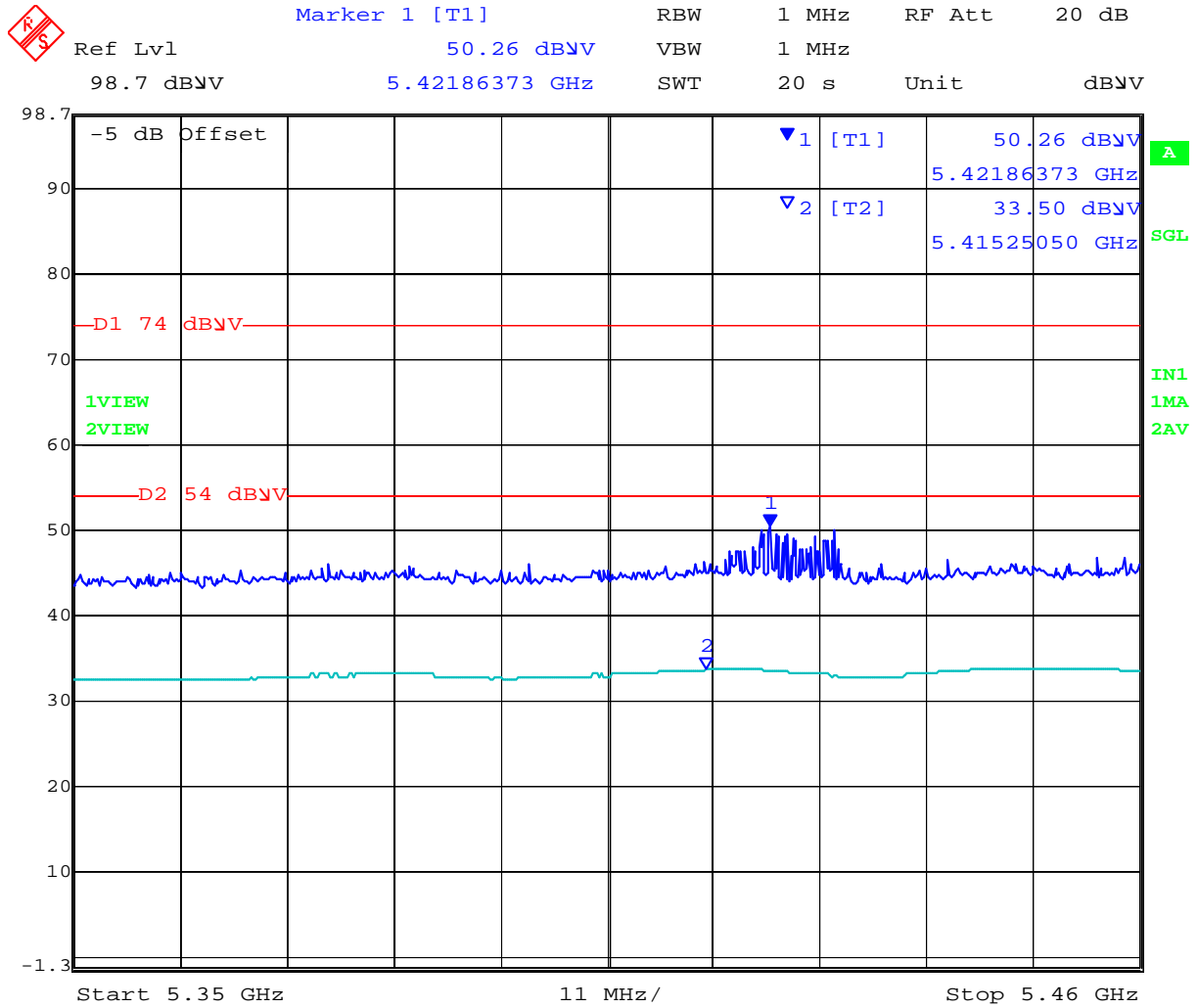

Date: 8.NOV.2013 15:53:30

This test report may be reproduced in full only. The document may only be updated by MiCOM Labs personnel. Any changes will be noted in the Document History section of the report.



Radiated Restricted Band-Edge

5460 MHz: 802.11n HT-20 5745 MHz

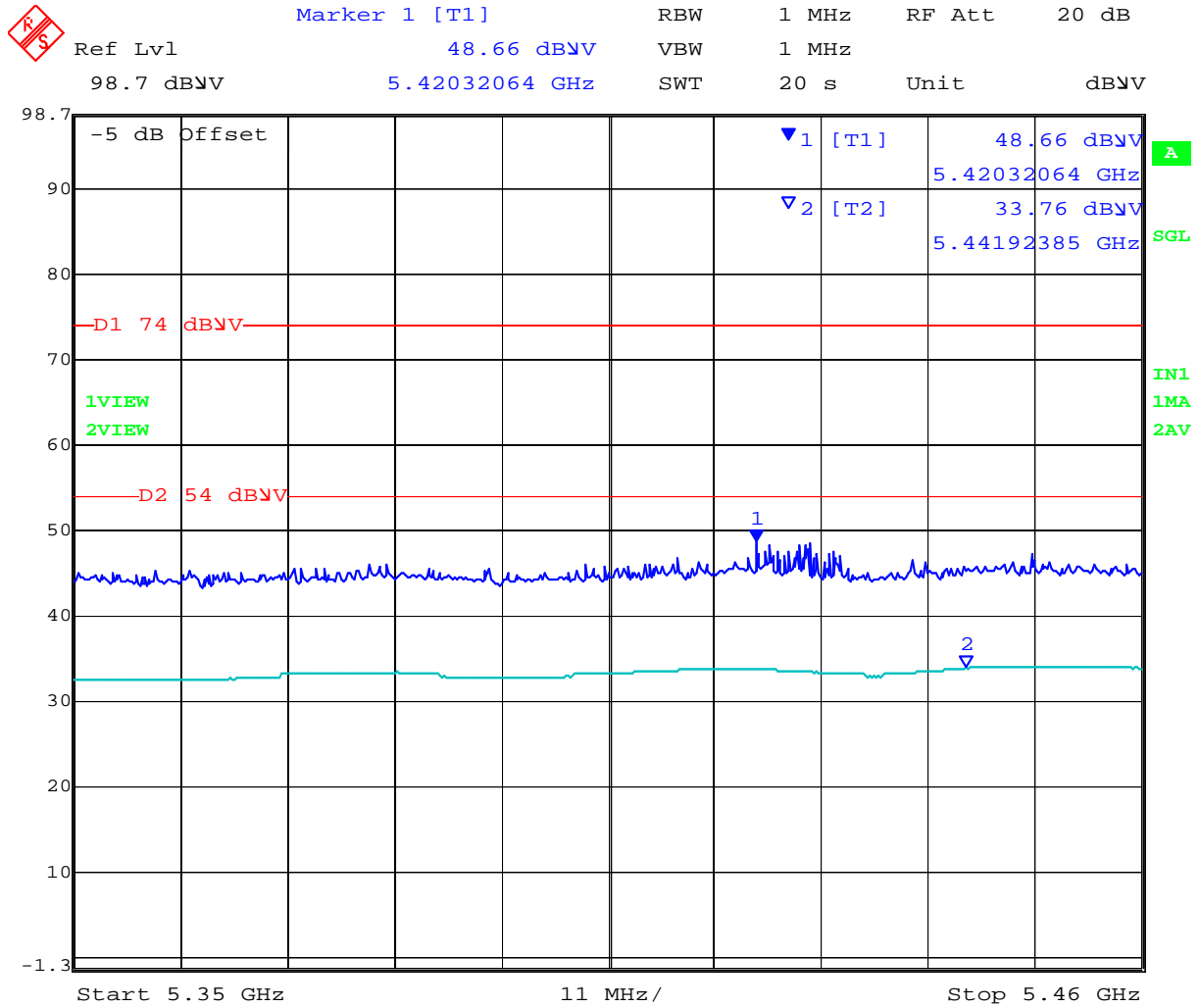

Date: 8.NOV.2013 15:55:17

This test report may be reproduced in full only. The document may only be updated by MiCOM Labs personnel. Any changes will be noted in the Document History section of the report.



6.1.2.3. Digital Emissions (0.03-1 GHz)

FCC, Part 15 Subpart C §15.205/ §15.209

Industry Canada RSS-Gen §7.2.5

Test Procedure

Testing 30M-1 GHz was performed in a 3-meter anechoic chamber using a CISPR compliant receiver. Preliminary radiated emissions were measured on every azimuth and with the receiving antenna in both horizontal and vertical polarizations. To further maximize emissions the receive antenna was varied between 1 and 4 meters. The emissions are recorded with receiver in peak hold mode. Emissions closest to the limits are measured in the quasi-peak mode with the tuned receiver using a bandwidth of 120 kHz. Only the highest emissions relative to the limit are listed. The anechoic chamber test set-up is identified in Section 6 Test Set-Up Photographs.

The EUT had two methods of powering on ac/dc converter and Power over Ethernet (POE). Both modes were tested for emissions below 1GHz.

Field Strength Calculation

The field strength is calculated by adding the Antenna Factor and Cable Loss, and subtracting Amplifier Gain from the measured reading. In this test facility, the Antenna Factor, Cable Loss, and Amplifier Gains are loaded into the Rohde & Schwarz Receiver and the corrected field strength can be read directly on the receiver.

$$FS = R + AF + CORR$$

where:

FS = Field Strength

R = Measured Receiver Input Amplitude

AF = Antenna Factor

CORR = Correction Factor = CL – AG + NFL

CL = Cable Loss

AG = Amplifier Gain

For example:

Given a Receiver input reading of 51.5dB μ V; Antenna Factor of 8.5dB; Cable Loss of 1.3dB; Falloff Factor of 0dB, an Amplifier Gain of 26dB and Notch Filter Loss of 1dB. The Field Strength of the measured emission is:

$$FS = 51.5 + 8.5 + 1.3 - 26.0 + 1 = 36.3\text{dB}\mu\text{V/m}$$

Conversion between dB μ V/m (or dB μ V) and μ V/m (or μ V) are done as:

$$\text{Level (dB}\mu\text{V/m)} = 20 * \text{Log (level (\mu\text{V/m}))}$$

$$40 \text{ dB}\mu\text{V/m} = 100\mu\text{V/m}$$

$$48 \text{ dB}\mu\text{V/m} = 250\mu\text{V/m}$$



Test Freq.	Not Applicable	Engineer	JMH
Variant	Digital Emissions	Temp (°C)	18
Freq. Range	30 MHz - 1000 MHz	Rel. Hum.(%)	37
Power Setting	Maximum	Press. (mBars)	997
Antenna	Not Applicable		
Test Notes 1	Basic Handset		
Test Notes 2	GCI 1 A Power Supply		

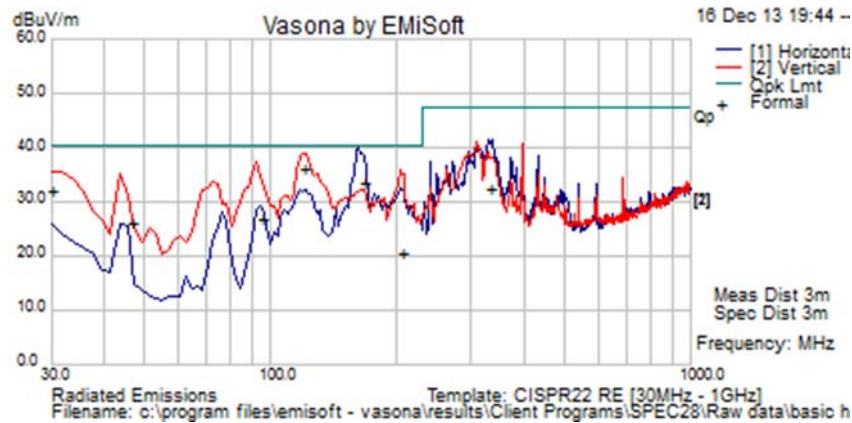

Formally measured emission peaks

Frequency MHz	Raw dBuV	Cable Loss	AF dB	Level dBuV/m	Measurement Type	Pol	Hgt cm	Azt Deg	Limit dBuV/m	Margin dB	Pass /Fail	Comments
30.165	38.1	3.5	-9.6	32.0	Quasi Max	V	99	294	40.5	-8.5	Pass	
46.784	43.8	3.7	-21.4	26.1	Quasi Max	V	104	202	40.5	-14.4	Pass	
95.281	45.0	4.0	-22.3	26.7	Quasi Max	V	142	33	40.5	-13.8	Pass	
119.128	49.2	4.2	-17.2	36.3	Quasi Max	V	108	348	40.5	-4.2	Pass	
166.022	47.8	4.5	-18.6	33.7	Quasi Max	H	166	74	40.5	-6.8	Pass	
203.657	34.6	4.7	-18.9	20.4	Quasi Max	V	99	121	40.5	-20.1	Pass	
330.190	43.8	5.2	-16.4	32.6	Quasi Max	H	110	144	47.5	-14.9	Pass	

Legend: DIG = Digital Device Emission; TX = Transmitter Emission; FUND = Fundamental Frequency
 NRB = Non-Restricted Band, Limit is 20 dB below Fundamental; RB = Restricted Band

This test report may be reproduced in full only. The document may only be updated by MiCOM Labs personnel. Any changes will be noted in the Document History section of the report.



Specification

Limits

§15.205 (a) Except as shown in paragraph (d) of 15.205 (a), only spurious emissions are permitted in any of the frequency bands listed.

§15.205 (a) Except as shown in paragraphs (d) and (e) of this section, the field strength of emissions appearing within these frequency bands shall not exceed the limits shown in Section §15.209. At frequencies equal to or less than 1000 MHz, compliance with the limits in Section 15.209 shall be demonstrated using measurement instrumentation employing a CISPR quasi-peak detector. Above 1000 MHz, compliance with the emission limits in Section 15.209 shall be demonstrated based on the average value of the measured emissions. The provisions in Section 15.35 apply to these measurements.

§15.209 (a) Except as provided elsewhere in this subpart, the emissions from an intentional radiator shall not exceed the field strength levels specified in the following table.

§15.209 (a) and Industry Canada RSS-Gen §7.2.5 Limit Matrix

Frequency(MHz)	Field Strength (µV/m)	Field Strength (dBµV/m)	Measurement Distance (meters)
30-88	100	40.0	3
88-216	150	43.5	3
216-960	200	46.0	3
Above 960	500	54.0	3

Laboratory Measurement Uncertainty for Radiated Emissions

Measurement uncertainty	+5.6/ -4.5 dB
-------------------------	---------------

Traceability

Method	Test Equipment Used
Measurements were made per work instruction WI-03 'Measurement of Radiated Emissions'	0088, 0158, 0134, 0304, 0311, 0315, 0310, 0312

6.1.3. AC Wireline Conducted Emissions (150 kHz – 30 MHz)

FCC, Part 15 Subpart C §15.207
Industry Canada RSS-Gen §7.2.4

Test Procedure

The EUT is configured in accordance with ANSI C63.4. The conducted emissions are measured in a shielded room with a spectrum analyzer in peak hold in the first instance. Emissions closest to the limit are measured in the quasi-peak mode (QP) with the tuned receiver using a bandwidth of 9 kHz. The emissions are maximized further by cable manipulation. The highest emissions relative to the limit are listed.

Test Measurement Set up

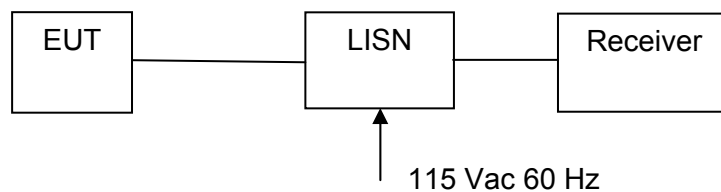

Measurement set up for AC Wireline Conducted Emissions Test

Measurement Results for AC Wireline Conducted Emissions (150 kHz – 30 MHz)

Ambient conditions.

Temperature: 17 to 23 °C Relative humidity: 31 to 57 % Pressure: 999 to 1012 mbar



Test Freq.	Not Applicable	Engineer	JMH
Variant	AC Line Emissions	Temp (°C)	11
Freq. Range	0.150 MHz - 30 MHz	Rel. Hum.(%)	27
Power Setting	Maximum	Press. (mBars)	1002
Antenna	Not Applicable		
Test Notes 1	110V 60 Hz PS GCI 1 A		

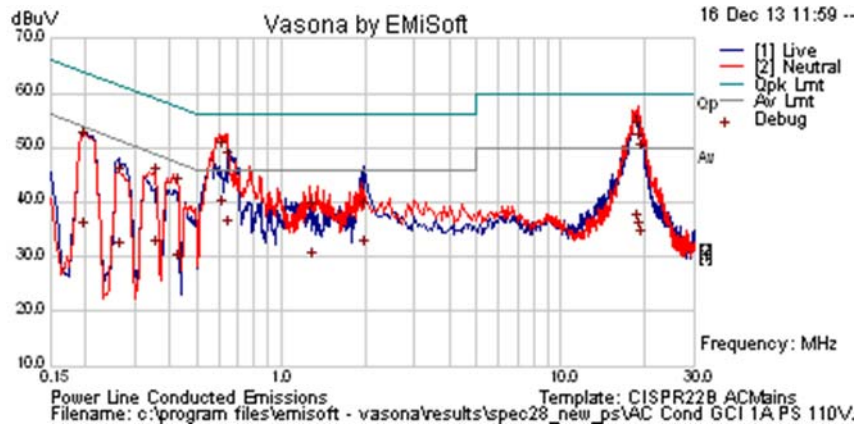

Formally measured emission peaks

Frequency MHz	Raw dBuV	Cable Loss	Factors dB	Level dBuV	Measurement Type	Line	Limit dBuV	Margin dB	Pass /Fail	Comments
0.195	41.1	9.9	0.1	51.1	Quasi Peak	Live	63.82	-12.8	Pass	
0.195	24.7	9.9	0.1	34.6	Average	Live	53.82	-19.2	Pass	
0.261	21.0	9.9	0.1	30.9	Average	Live	51.4	-20.5	Pass	
0.261	34.6	9.9	0.1	44.6	Quasi Peak	Live	61.4	-16.8	Pass	
0.352	21.3	9.9	0.1	31.3	Average	Neutral	48.92	-17.6	Pass	
0.352	34.6	9.9	0.1	44.5	Quasi Peak	Neutral	58.92	-14.4	Pass	
0.423	32.9	9.9	0.1	42.8	Quasi Peak	Neutral	57.39	-14.6	Pass	
0.423	18.8	9.9	0.1	28.7	Average	Neutral	47.39	-18.6	Pass	
0.614	39.3	10.0	0.1	49.4	Quasi Peak	Neutral	56	-6.6	Pass	
0.614	28.7	10.0	0.1	38.7	Average	Neutral	46	-7.3	Pass	
0.638	37.6	10.0	0.1	47.7	Quasi Peak	Neutral	56	-8.3	Pass	
0.638	25.1	10.0	0.1	35.1	Average	Neutral	46	-10.9	Pass	
1.273	28.3	10.0	0.1	38.4	Quasi Peak	Neutral	56	-17.7	Pass	
1.273	19.1	10.0	0.1	29.2	Average	Neutral	46	-16.9	Pass	
1.953	21.2	10.0	0.1	31.4	Average	Live	46	-14.6	Pass	
1.953	28.2	10.0	0.1	38.4	Quasi Peak	Live	56	-17.7	Pass	
18.699	24.9	10.5	0.7	36.1	Average	Neutral	50	-13.9	Pass	
18.699	41.9	10.5	0.7	53.1	Quasi Peak	Neutral	60	-6.9	Pass	
18.980	39.6	10.5	0.7	50.8	Quasi Peak	Neutral	60	-9.2	Pass	
18.980	23.6	10.5	0.7	34.8	Average	Neutral	50	-15.2	Pass	
19.094	37.9	10.5	0.7	49.2	Quasi Peak	Neutral	60	-10.8	Pass	
19.094	21.9	10.5	0.7	33.1	Average	Neutral	50	-16.9	Pass	

Legend: DIG = Digital Device Emission; TX = Transmitter Emission; FUND = Fundamental Frequency
 NRB = Non-Restricted Band, Limit is 20 dB below Fundamental; RB = Restricted Band

This test report may be reproduced in full only. The document may only be updated by MiCOM Labs personnel. Any changes will be noted in the Document History section of the report.



Title: Spectralink 8741 Basic IP Telephone
To: FCC 47 CFR Part 15.247 & IC RSS-210
Serial #: SPEC27-U4 Rev A
Issue Date: 1st January 2014
Page: 77 of 154

Test Freq.	Not Applicable	Engineer	JMH
Variant	AC Line Emissions	Temp (°C)	11
Freq. Range	0.150 MHz - 30 MHz	Rel. Hum.(%)	27
Power Setting		Press. (mBars)	1002
Antenna			
Test Notes 1	110V 60 Hz JE1.5A Power Supply		

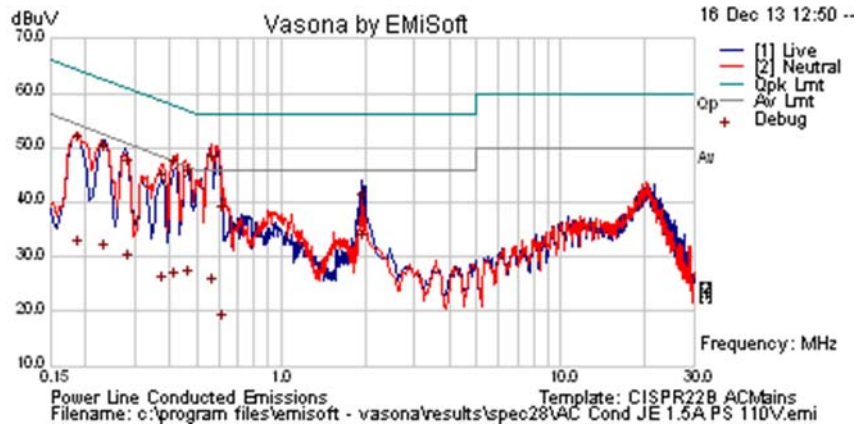

Formally measured emission peaks

Frequency MHz	Raw dBuV	Cable Loss	Factors dB	Level dBuV	Measurement Type	Line	Limit dBuV	Margin dB	Pass /Fail	Comments
0.186	21.4	9.9	0.1	31.4	Average	Neutral	54.2	-22.8	Pass	
0.186	40.6	9.9	0.1	50.6	Quasi Peak	Neutral	64.2	-13.6	Pass	
0.232	38.8	9.9	0.1	48.8	Quasi Peak	Live	62.38	-13.6	Pass	
0.232	20.5	9.9	0.1	30.5	Average	Live	52.38	-21.9	Pass	
0.279	36.2	9.9	0.1	46.2	Quasi Peak	Live	60.83	-14.7	Pass	
0.279	18.7	9.9	0.1	28.7	Average	Live	50.83	-22.1	Pass	
0.374	14.9	9.9	0.1	24.8	Average	Neutral	48.42	-23.6	Pass	
0.374	33.5	9.9	0.1	43.5	Quasi Peak	Neutral	58.42	-15.0	Pass	
0.408	15.7	9.9	0.1	25.6	Average	Neutral	47.69	-22.1	Pass	
0.408	36.0	9.9	0.1	45.9	Quasi Peak	Neutral	57.69	-11.8	Pass	
0.459	15.7	9.9	0.1	25.7	Average	Neutral	46.7	-21.0	Pass	
0.459	34.4	9.9	0.1	44.4	Quasi Peak	Neutral	56.7	-12.3	Pass	
0.564	14.3	9.9	0.1	24.3	Average	Neutral	46	-21.7	Pass	
0.564	36.9	9.9	0.1	46.9	Quasi Peak	Neutral	56	-9.1	Pass	
1.948	22.2	10.0	0.1	32.3	Average	Live	46	-13.7	Pass	
1.948	29.8	10.0	0.1	39.9	Quasi Peak	Live	56	-16.1	Pass	

Legend: DIG = Digital Device Emission; TX = Transmitter Emission; FUND = Fundamental Frequency
 NRB = Non-Restricted Band, Limit is 20 dB below Fundamental; RB = Restricted Band

This test report may be reproduced in full only. The document may only be updated by MiCOM Labs personnel. Any changes will be noted in the Document History section of the report.



Specification

Limit

§15.207 (a) Except as shown in paragraphs (b) and (c) of this section, for an intentional radiator that is designed to be connected to the public utility (AC) power line, the radio frequency voltage that is conducted back onto the AC power line on any frequency or frequencies within the band 150 kHz to 30 MHz shall not exceed the limits in the following table, as measured using a 50 $\mu\Omega$ line impedance stabilization network (LISN), see §15.207 (a) matrix below. Compliance with the provisions of this paragraph shall be based on the measurement of the radio frequency voltage between each power line and ground at the power terminal.

RSS-Gen §7.2.4

Except when the requirements applicable to a given device state otherwise, for any radio apparatus equipped to operate from the public utility AC power supply, either directly or indirectly (such as with a battery charger), the radio frequency voltage of emissions conducted back onto the AC power lines in the frequency range of 0.15 MHz to 30 MHz shall not exceed the limits shown in the table below. The more stringent limit applies at the frequency range boundaries. The conducted emissions shall be measured with a 50 ohm/50 microhenry line impedance stabilization network (LISN).

§15.207 (a) and RSS-Gen §7.2.4 Limit Matrix

The lower limit applies at the boundary between frequency ranges

Frequency of Emission (MHz)	Conducted Limit (dB μ V)	
	Quasi-peak	Average
0.15-0.5	66 to 56*	56 to 46*
0.5-5	56	46
5-30	60	50

* Decreases with the logarithm of the frequency

Laboratory Measurement Uncertainty for Conducted Emissions

Measurement uncertainty	± 2.64 dB
-------------------------	---------------

Traceability

Method	Test Equipment Used
Measurements were made per work instruction WI-EMC-01 'Measurement of Conducted Emissions'	0158, 0184, 0287, 0190, 0293, 0307

This test report may be reproduced in full only. The document may only be updated by MiCOM Labs personnel. Any changes will be noted in the Document History section of the report.

7. PHOTOGRAPHS

7.1. Test Setup – RF Conducted

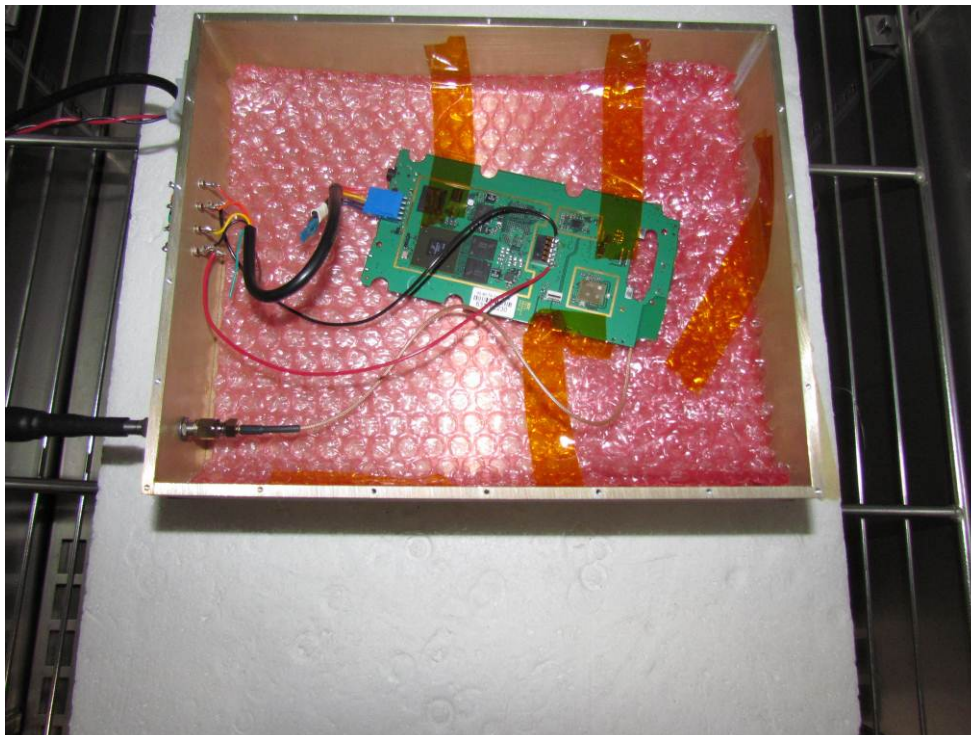

This test report may be reproduced in full only. The document may only be updated by MiCOM Labs personnel. Any changes will be noted in the Document History section of the report.

7.2. Test Setup - Digital Emissions 0.03 - 1 GHz

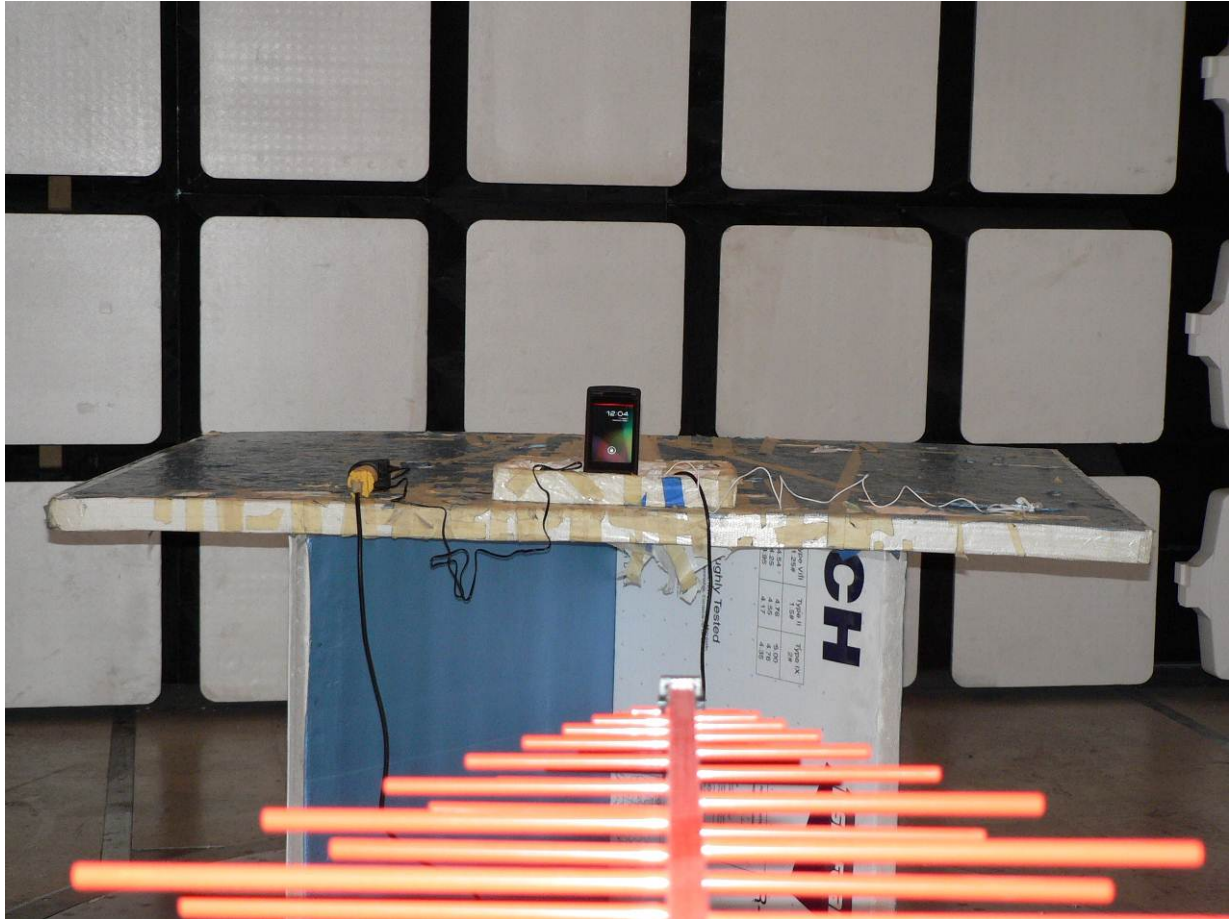

This test report may be reproduced in full only. The document may only be updated by MiCOM Labs personnel. Any changes will be noted in the Document History section of the report.

7.3. Test Setup - Spurious Emissions > 1 GHz



This test report may be reproduced in full only. The document may only be updated by MiCOM Labs personnel. Any changes will be noted in the Document History section of the report.



8. TEST EQUIPMENT

Asset #	Instrument	Manufacturer	Part #	Serial #	Calibration Due Date
0117	Power Sensor	Hewlett Packard	8487D	3318A00371	18 th Oct 14
0223	Power Meter	Hewlett Packard	EPM-442A	US37480256	18 th Oct 14
0376	Power Sensor	Agilent	U2000A	MY51440005	28 th Oct 14
0390	Power Sensor	Agilent	U2002A	MY50000103	17 th Oct 14
0158	Barometer /Thermometer	Control Co.	4196	E2846	8 th Jan 14
0193	EMI Receiver	Rhode & Schwartz	ESI 7	838496/007	2 nd Dec 13
0287	EMI Receiver	Rhode & Schwartz	ESIB40	100201	31 st Jul 14
0378	EMI Receiver	Rhode & Schwartz	ESIB40	100107/040	17 th Jul 14
0338	30 - 3000 MHz Antenna	Sunol	JB3	A052907	14 th Aug 14
0399	1-18 GHz Horn Antenna	EMCO	3117	00154575	10 th Oct 14
0252	SMA Cable	Megaphase	Sucoflex 104	None	N/A
0310	2m SMA Cable	Micro-Coax	UFA210A-0- 0787-3G03G0	209089-001	N/A
0312	3m SMA Cable	Micro-Coax	UFA210A-1- 1181-3G0300	209092-001	N/A
0314	30dB N-Type Attenuator	ARRA	N9444-30	1623	N/A
0359	DFS Test System	Aeroflex	PXI-1042	300001/004	21 st Oct 14
0299	DFS Test Software	Aeroflex	PXI Module	Version 7.1.0	N/A
0502	EMC Test Software	EMISoft	Vasona	5.0051	N/A
0503	RF Conducted Test Software	National Instruments	Labview	Version 8.2	N/A
0398	RF Conducted Test Software	MiCOM Labs ATS	--	Version 1.8	N/A
0380	RF Switch	MiCOM Labs	MIC001	MIC001	20 th Dec 13

This test report may be reproduced in full only. The document may only be updated by MiCOM Labs personnel. Any changes will be noted in the Document History section of the report.



Title: Spectralink 8741 Basic IP Telephone
To: FCC 47 CFR Part 15.247 & IC RSS-210
Serial #: SPEC27-U4 Rev A
Issue Date: 1st January 2014
Page: 83 of 154

APPENDIX

A. SUPPORTING INFORMATION

A.1. CONDUCTED TEST PLOTS

This test report may be reproduced in full only. The document may only be updated by MiCOM Labs personnel. Any changes will be noted in the Document History section of the report.



A.1.1. 6 dB & 99% Bandwidth



6 dB & 99% BANDWIDTH

Variant: 802.11b, Channel: 2412.00 MHz, Chain a, Temp: Ambient, Voltage: 3.6 Vdc

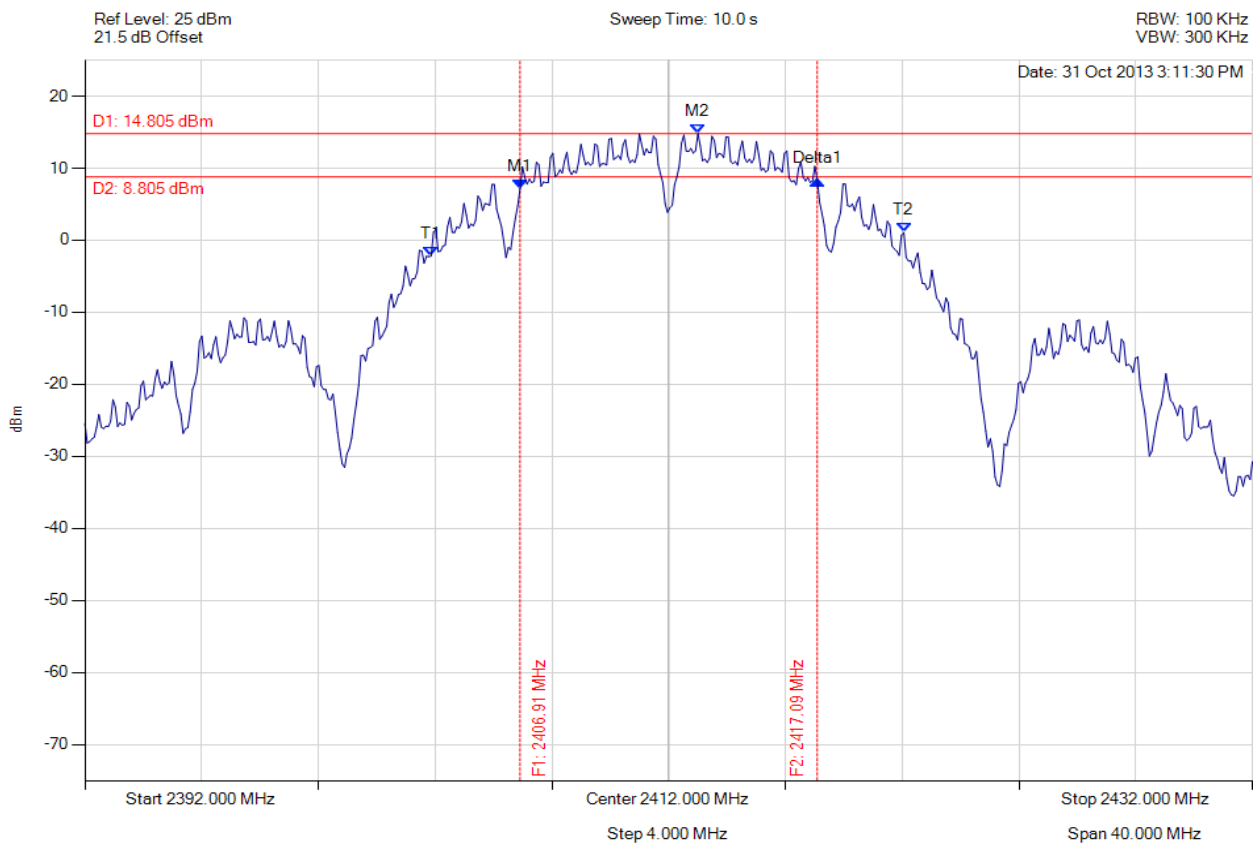

Analyser Setup	Marker : Frequency : Amplitude	Test Results
Detector = MAX PEAK Sweep Count = 0 RF Atten (dB) = 20 Trace Mode = VIEW	M1 : 2406.910 MHz : 7.180 dBm M2 : 2413.002 MHz : 14.805 dBm Delta1 : 10.180 MHz : 1.141 dB T1 : 2403.864 MHz : -2.187 dBm T2 : 2420.056 MHz : 1.069 dBm OBW : 16.192 MHz	Measured 6 dB Bandwidth: 10.180 MHz Limit: ≥500.0 kHz Margin: -9.68 MHz

[Back to the Matrix](#)

This test report may be reproduced in full only. The document may only be updated by MiCOM Labs personnel. Any changes will be noted in the Document History section of the report.



6 dB & 99% BANDWIDTH

Variant: 802.11b, Channel: 2437.00 MHz, Chain a, Temp: Ambient, Voltage: 3.6 Vdc

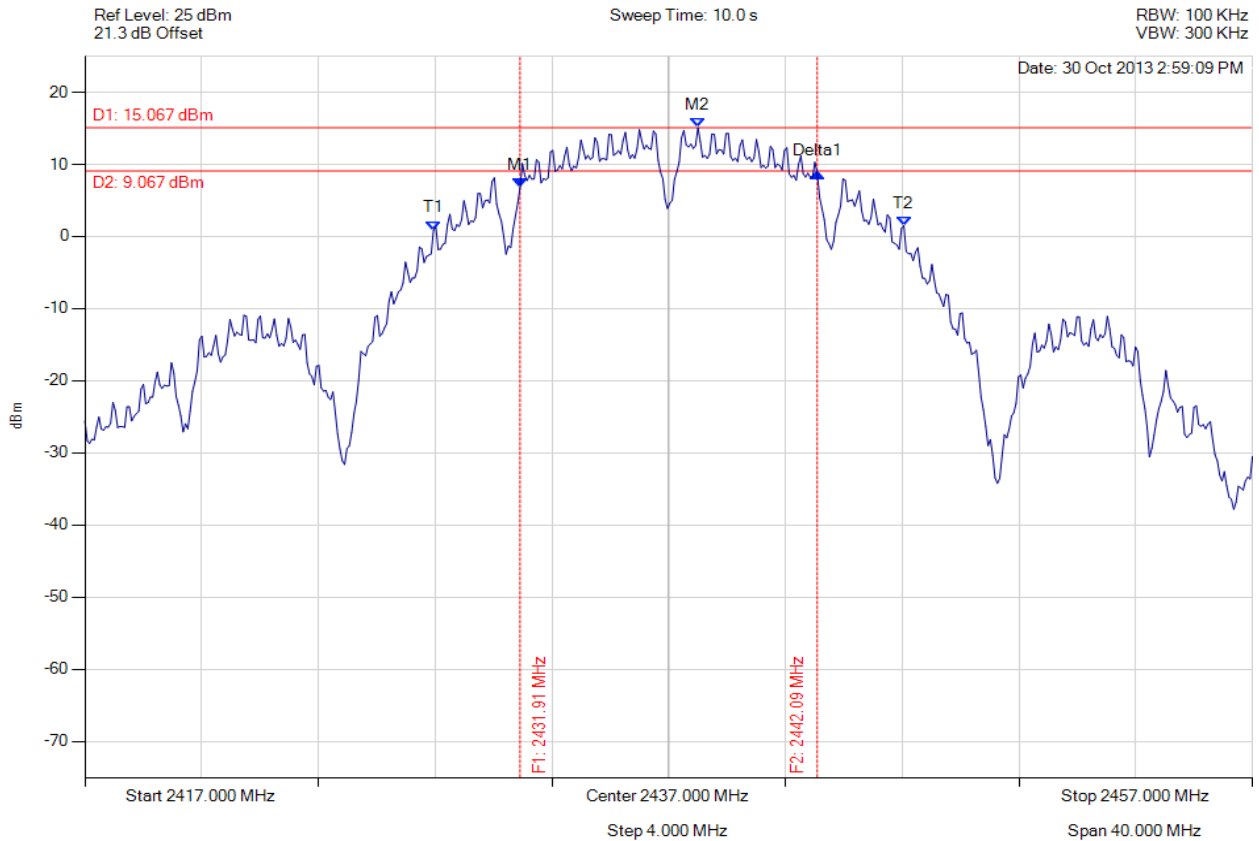

Analyser Setup	Marker : Frequency : Amplitude	Test Results
Detector = MAX PEAK Sweep Count = 0 RF Atten (dB) = 20 Trace Mode = VIEW	M1 : 2431.910 MHz : 6.831 dBm M2 : 2438.002 MHz : 15.067 dBm Delta1 : 10.180 MHz : 1.916 dB T1 : 2428.944 MHz : 0.882 dBm T2 : 2445.056 MHz : 1.510 dBm OBW : 16.112 MHz	Measured 6 dB Bandwidth: 10.180 MHz Limit: ≥ 500.0 kHz Margin: -9.68 MHz

[Back to the Matrix](#)

This test report may be reproduced in full only. The document may only be updated by MiCOM Labs personnel. Any changes will be noted in the Document History section of the report.



6 dB & 99% BANDWIDTH

Variant: 802.11b, Channel: 2462.00 MHz, Chain a, Temp: Ambient, Voltage: 3.6 Vdc

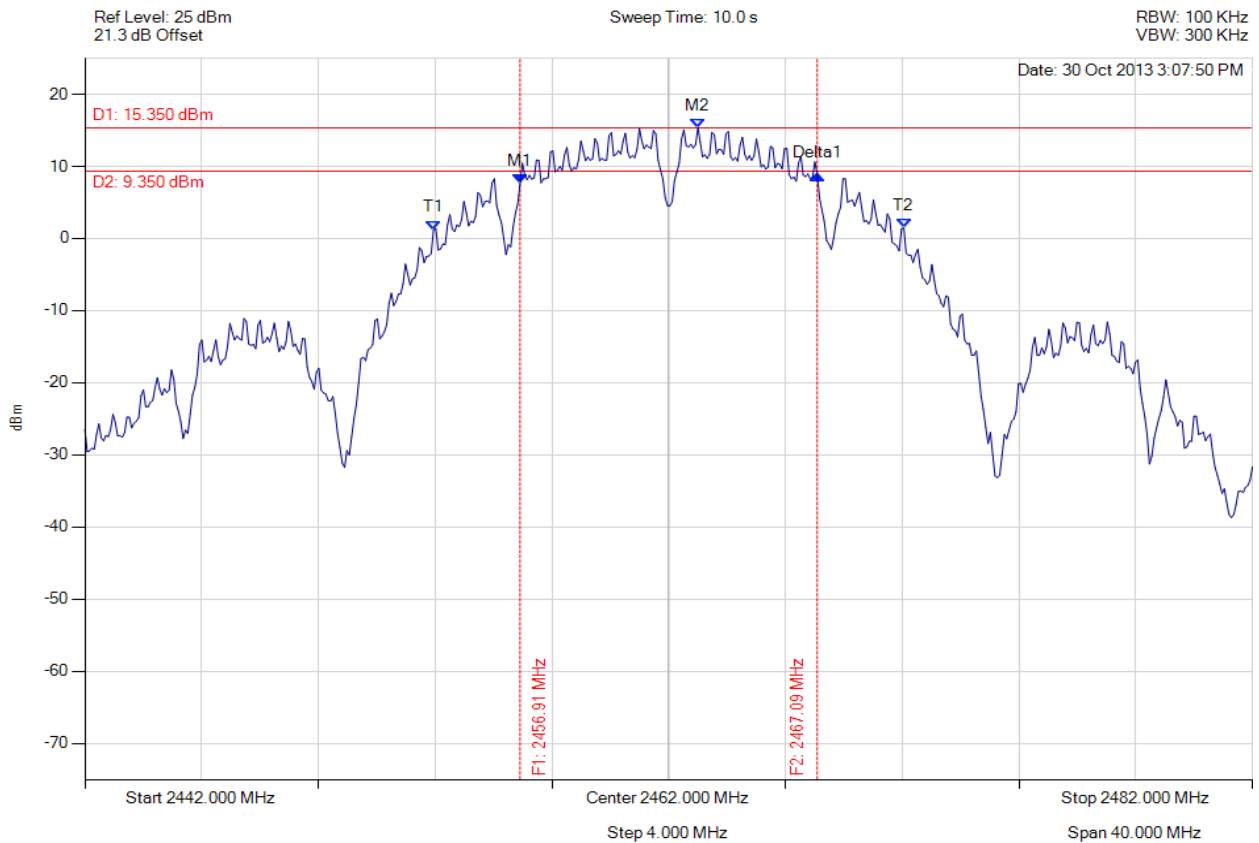

Analyser Setup	Marker : Frequency : Amplitude	Test Results
Detector = MAX PEAK Sweep Count = 0 RF Atten (dB) = 20 Trace Mode = VIEW	M1 : 2456.910 MHz : 7.626 dBm M2 : 2463.002 MHz : 15.350 dBm Delta1 : 10.180 MHz : 1.202 dB T1 : 2453.944 MHz : 1.215 dBm T2 : 2470.056 MHz : 1.488 dBm OBW : 16.112 MHz	Measured 6 dB Bandwidth: 10.180 MHz Limit: ≥ 500.0 kHz Margin: -9.68 MHz

[Back to the Matrix](#)

This test report may be reproduced in full only. The document may only be updated by MiCOM Labs personnel. Any changes will be noted in the Document History section of the report.

6 dB & 99% BANDWIDTH

Variant: 802.11g, Channel: 2412.00 MHz, Chain a, Temp: Ambient, Voltage: 3.6 Vdc

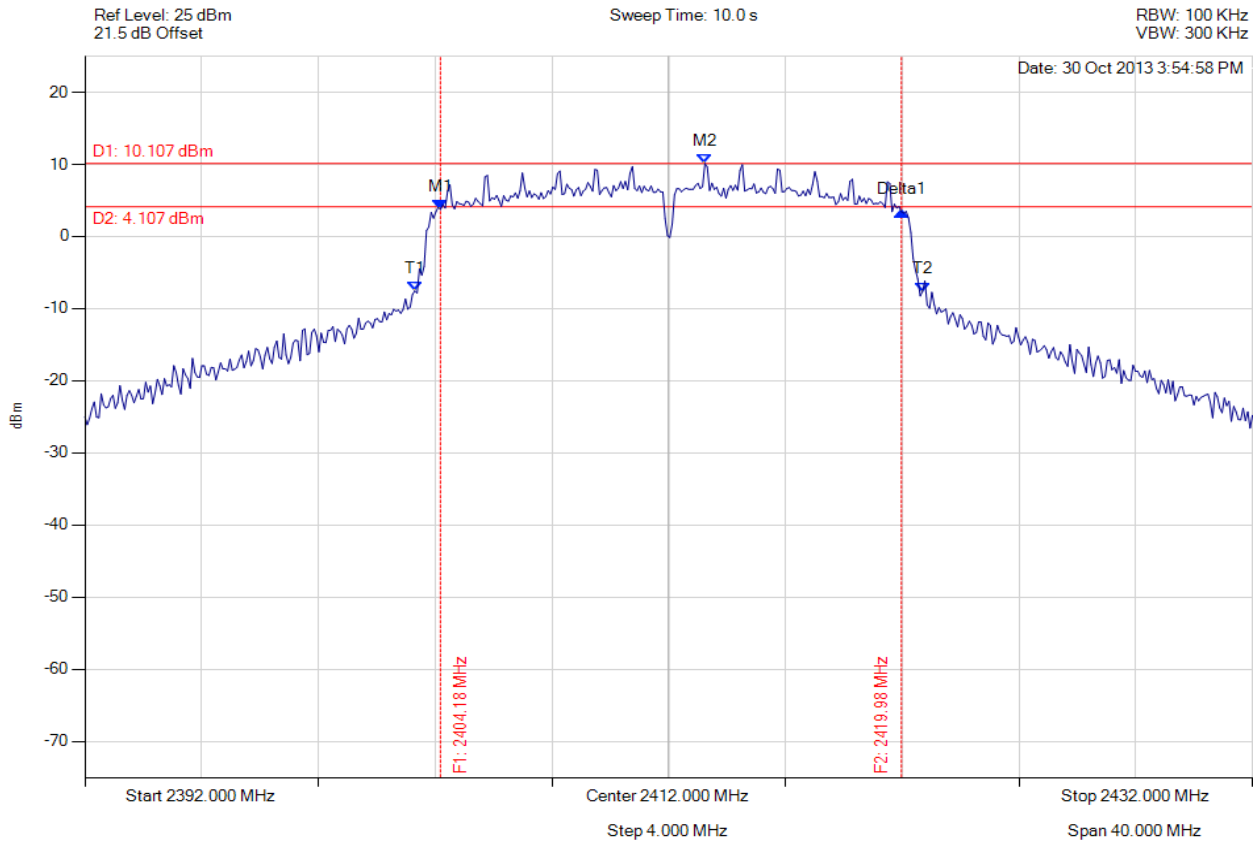

Analyser Setup	Marker : Frequency : Amplitude	Test Results
Detector = MAX PEAK Sweep Count = 0 RF Atten (dB) = 20 Trace Mode = VIEW	M1 : 2404.184 MHz : 3.741 dBm M2 : 2413.242 MHz : 10.107 dBm Delta1 : 15.792 MHz : -0.309 dB T1 : 2403.303 MHz : -7.542 dBm T2 : 2420.697 MHz : -7.621 dBm OBW : 17.395 MHz	Measured 6 dB Bandwidth: 15.792 MHz Limit: ≥500.0 kHz Margin: -15.29 MHz

[Back to the Matrix](#)

This test report may be reproduced in full only. The document may only be updated by MiCOM Labs personnel. Any changes will be noted in the Document History section of the report.



6 dB & 99% BANDWIDTH

Variant: 802.11g, Channel: 2437.00 MHz, Chain a, Temp: Ambient, Voltage: 3.6 Vdc

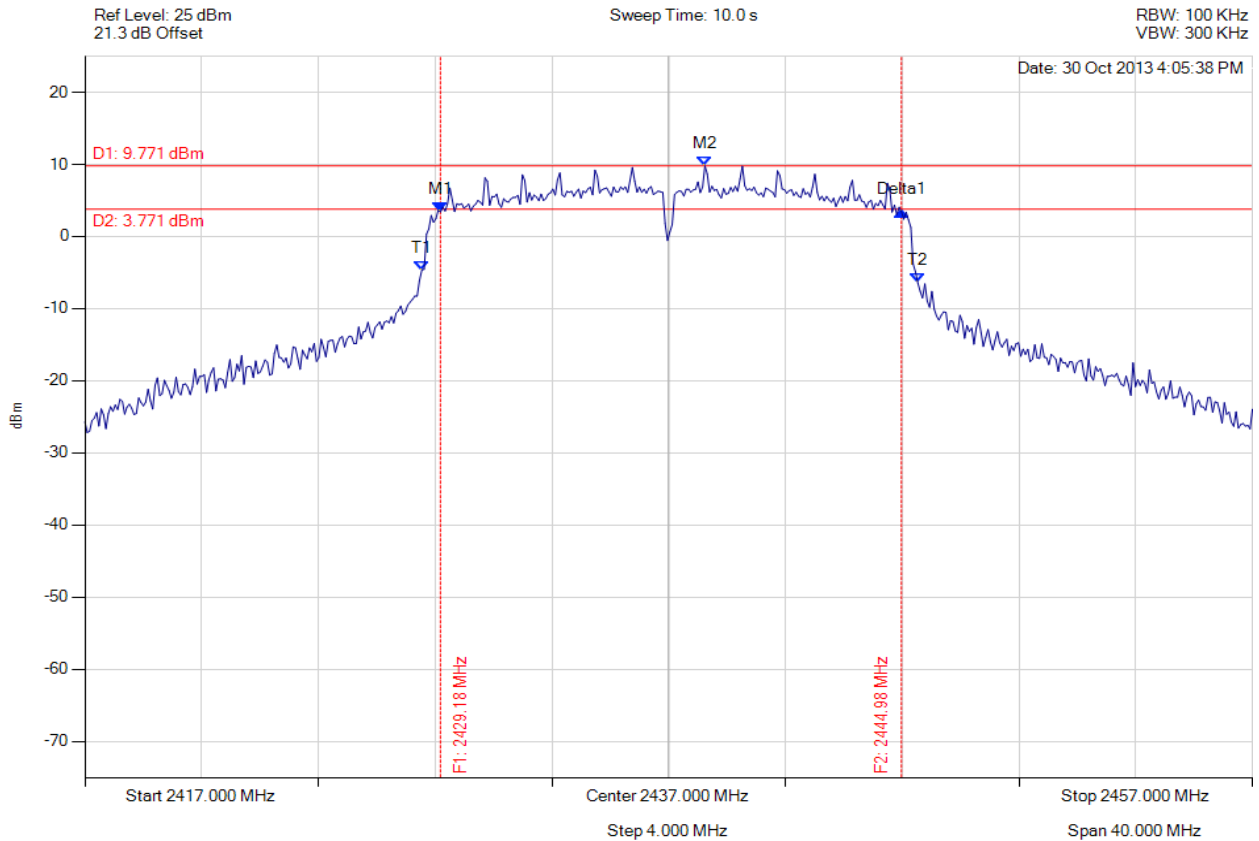

Analyser Setup	Marker : Frequency : Amplitude	Test Results
Detector = MAX PEAK Sweep Count = 0 RF Atten (dB) = 20 Trace Mode = VIEW	M1 : 2429.184 MHz : 3.412 dBm M2 : 2438.242 MHz : 9.771 dBm Delta1 : 15.792 MHz : 0.016 dB T1 : 2428.543 MHz : -4.648 dBm T2 : 2445.537 MHz : -6.442 dBm OBW : 16.994 MHz	Measured 6 dB Bandwidth: 15.792 MHz Limit: ≥ 500.0 kHz Margin: -15.29 MHz

[Back to the Matrix](#)

This test report may be reproduced in full only. The document may only be updated by MiCOM Labs personnel. Any changes will be noted in the Document History section of the report.



6 dB & 99% BANDWIDTH

Variant: 802.11g, Channel: 2462.00 MHz, Chain a, Temp: Ambient, Voltage: 3.6 Vdc

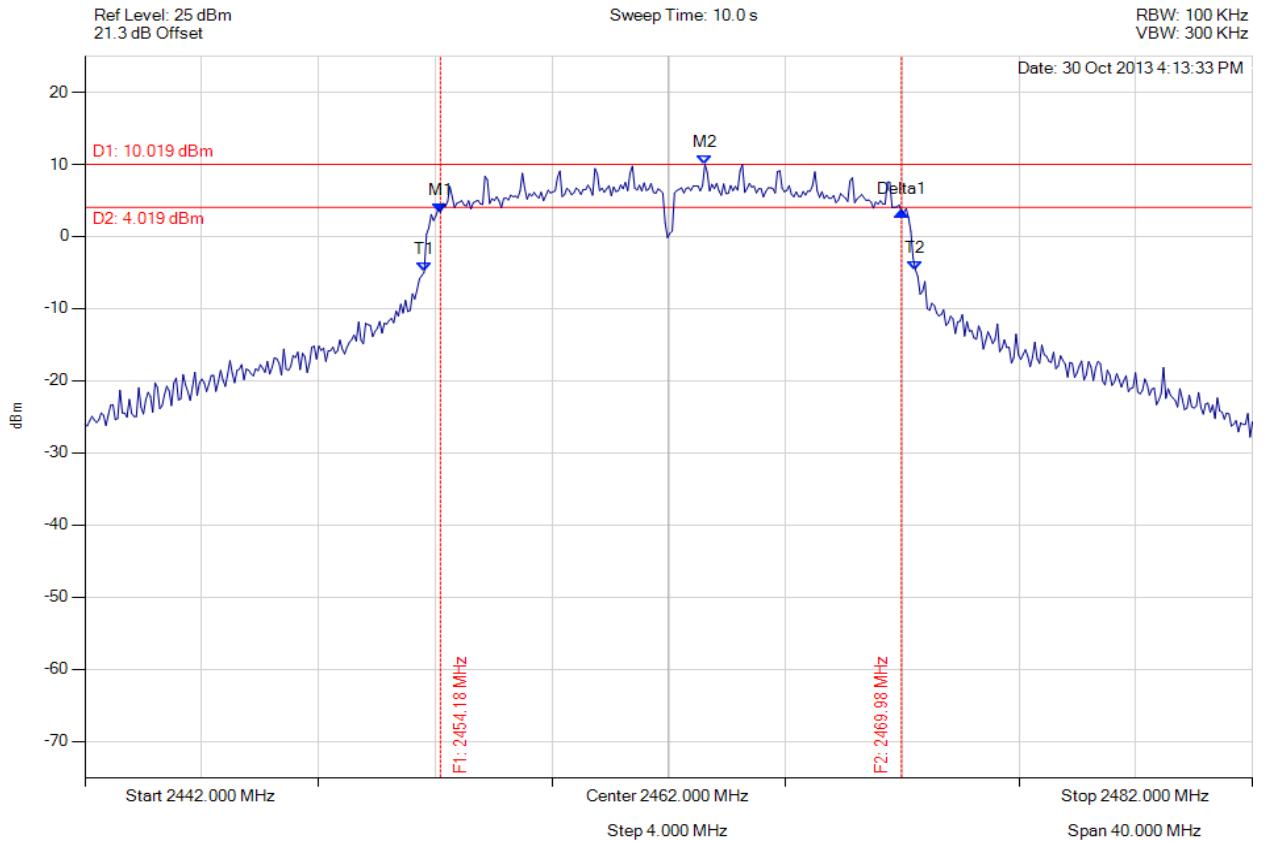

Analyser Setup	Marker : Frequency : Amplitude	Test Results
Detector = MAX PEAK Sweep Count = 0 RF Atten (dB) = 20 Trace Mode = VIEW	M1 : 2454.184 MHz : 3.308 dBm M2 : 2463.242 MHz : 10.019 dBm Delta1 : 15.792 MHz : 0.177 dB T1 : 2453.623 MHz : -4.947 dBm T2 : 2470.457 MHz : -4.672 dBm OBW : 16.834 MHz	Measured 6 dB Bandwidth: 15.792 MHz Limit: \geq 500.0 kHz Margin: -15.29 MHz

[Back to the Matrix](#)

This test report may be reproduced in full only. The document may only be updated by MiCOM Labs personnel. Any changes will be noted in the Document History section of the report.

6 dB & 99% BANDWIDTH

Variant: 802.11n HT-20, Channel: 2412.00 MHz, Chain a, Temp: Ambient, Voltage: 3.6 Vdc

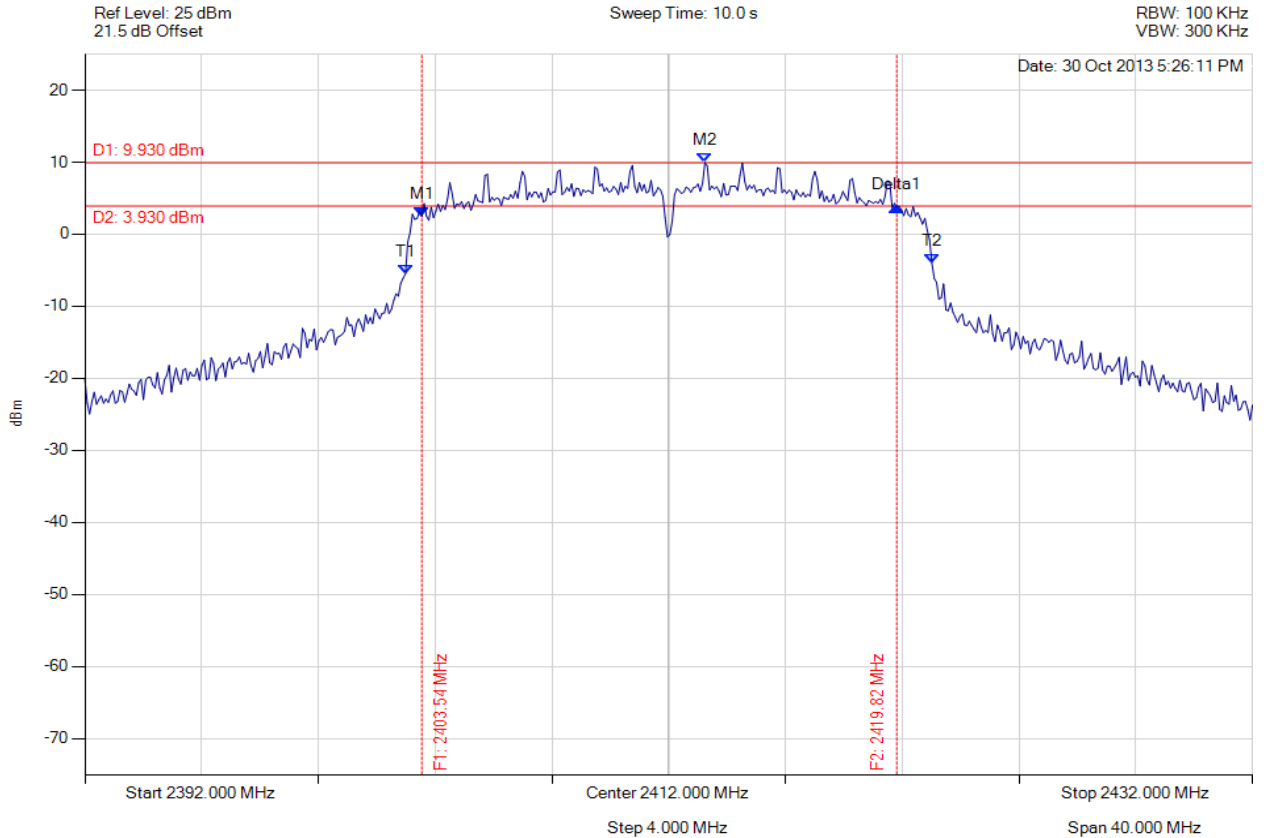

Analyser Setup	Marker : Frequency : Amplitude	Test Results
Detector = MAX PEAK Sweep Count = 0 RF Atten (dB) = 20 Trace Mode = VIEW	M1 : 2403.543 MHz : 2.429 dBm M2 : 2413.242 MHz : 9.930 dBm Delta1 : 16.273 MHz : 1.397 dB T1 : 2402.982 MHz : -5.470 dBm T2 : 2421.018 MHz : -3.981 dBm OBW : 18.036 MHz	Measured 6 dB Bandwidth: 16.273 MHz Limit: ≥ 500.0 kHz Margin: -15.77 MHz

[Back to the Matrix](#)

This test report may be reproduced in full only. The document may only be updated by MiCOM Labs personnel. Any changes will be noted in the Document History section of the report.

6 dB & 99% BANDWIDTH

Variant: 802.11n HT-20, Channel: 2437.00 MHz, Chain a, Temp: Ambient, Voltage: 3.6 Vdc

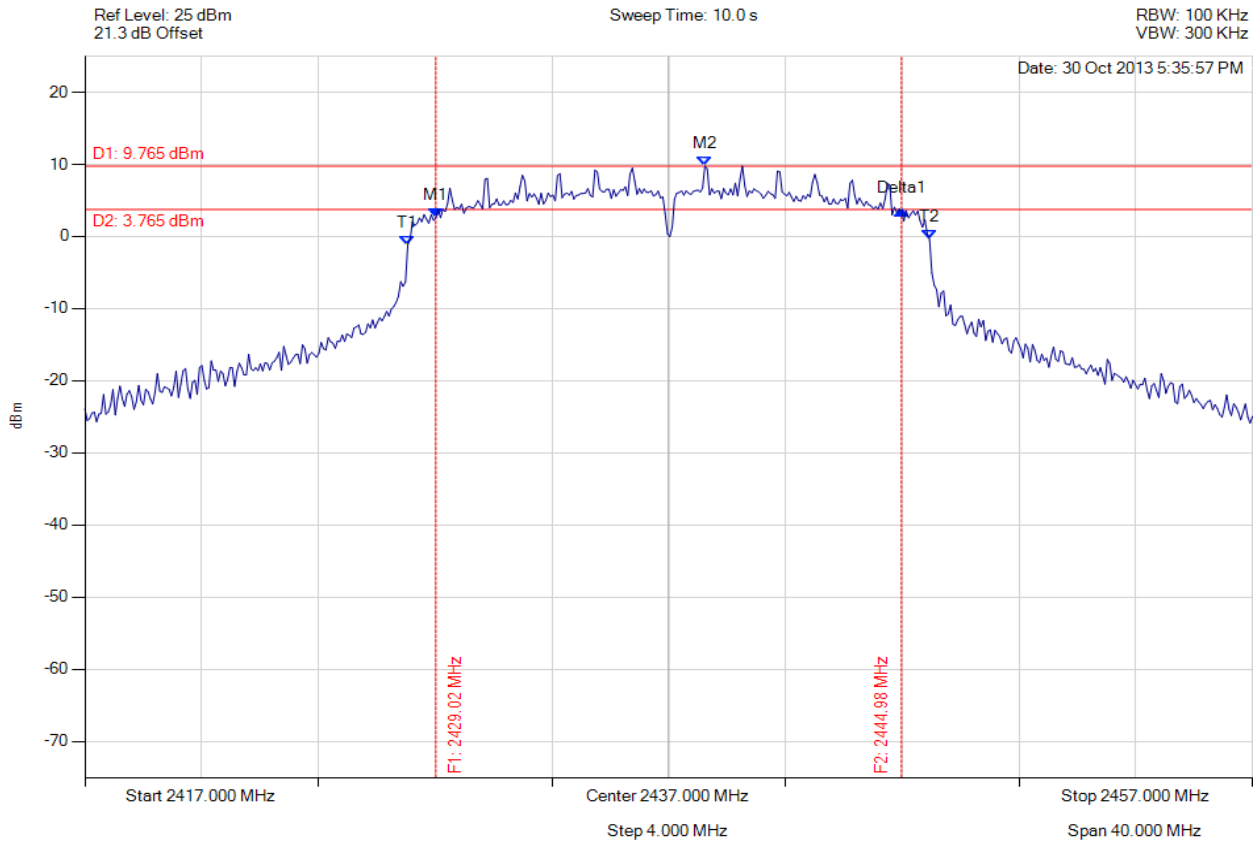

Analyser Setup	Marker : Frequency : Amplitude	Test Results
Detector = MAX PEAK Sweep Count = 0 RF Atten (dB) = 20 Trace Mode = VIEW	M1 : 2429.024 MHz : 2.606 dBm M2 : 2438.242 MHz : 9.765 dBm Delta1 : 15.952 MHz : 1.015 dB T1 : 2428.062 MHz : -1.168 dBm T2 : 2445.938 MHz : -0.442 dBm OBW : 17.876 MHz	Measured 6 dB Bandwidth: 15.952 MHz Limit: ≥500.0 kHz Margin: -15.45 MHz

[Back to the Matrix](#)

This test report may be reproduced in full only. The document may only be updated by MiCOM Labs personnel. Any changes will be noted in the Document History section of the report.



6 dB & 99% BANDWIDTH

Variant: 802.11n HT-20, Channel: 2462.00 MHz, Chain a, Temp: Ambient, Voltage: 3.6 Vdc

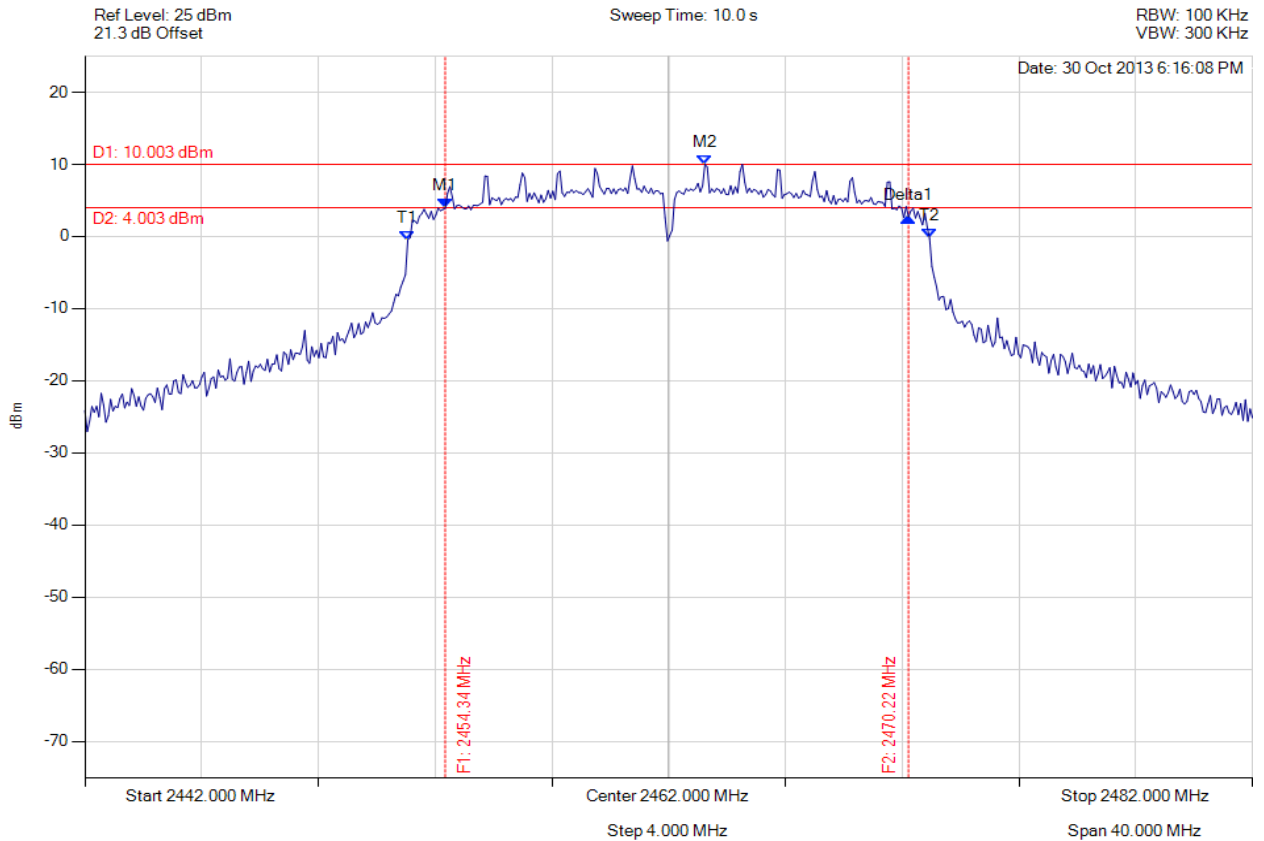

Analyser Setup	Marker : Frequency : Amplitude	Test Results
Detector = MAX PEAK Sweep Count = 0 RF Atten (dB) = 20 Trace Mode = VIEW	M1 : 2454.345 MHz : 3.918 dBm M2 : 2463.242 MHz : 10.003 dBm Delta1 : 15.872 MHz : -1.212 dB T1 : 2453.062 MHz : -0.485 dBm T2 : 2470.938 MHz : -0.275 dBm OBW : 17.876 MHz	Measured 6 dB Bandwidth: 15.872 MHz Limit: ≥ 500.0 kHz Margin: -15.37 MHz

[Back to the Matrix](#)

This test report may be reproduced in full only. The document may only be updated by MiCOM Labs personnel. Any changes will be noted in the Document History section of the report.

6 dB & 99% BANDWIDTH

Variant: 802.11a, Channel: 5745.00 MHz, Chain a, Temp: Ambient, Voltage: 3.6 Vdc

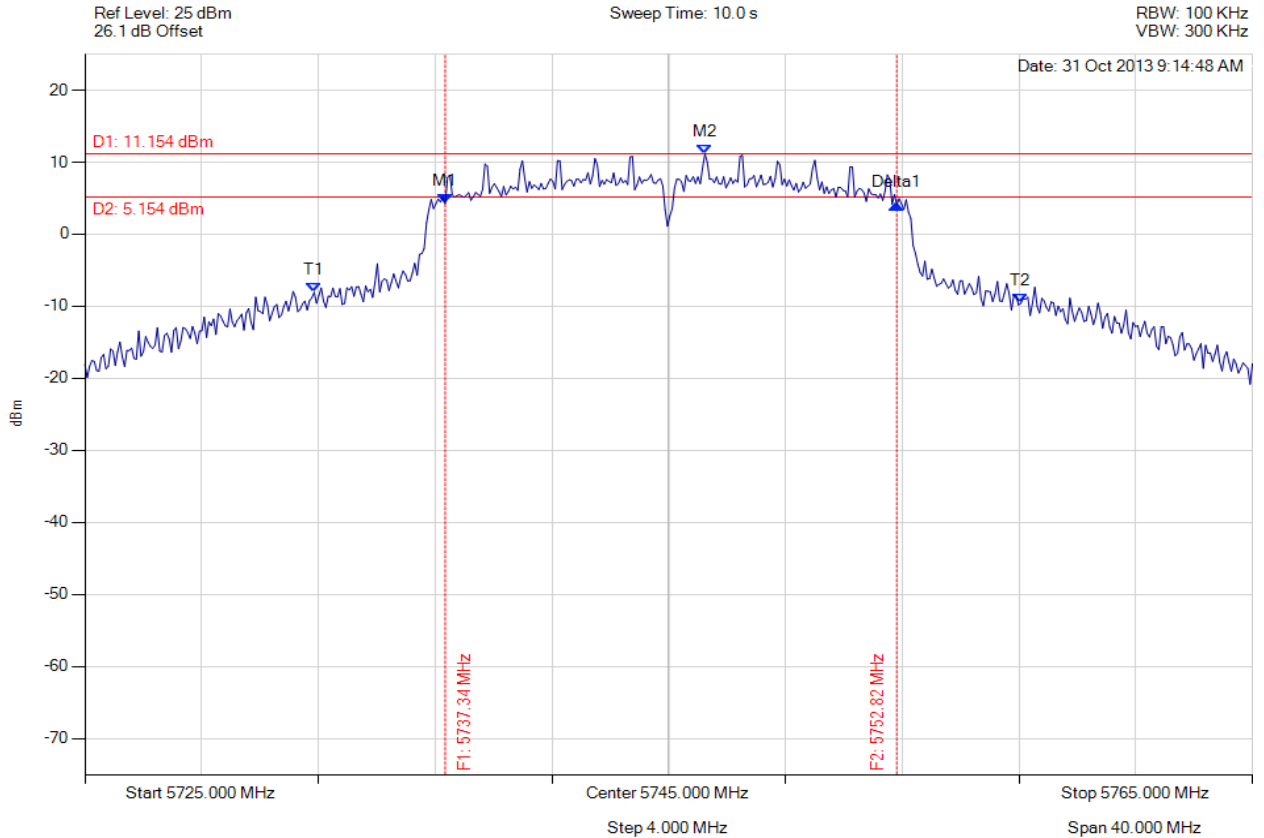

Analyser Setup	Marker : Frequency : Amplitude	Test Results
Detector = MAX PEAK Sweep Count = 0 RF Atten (dB) = 20 Trace Mode = VIEW	M1 : 5737.345 MHz : 4.244 dBm M2 : 5746.242 MHz : 11.154 dBm Delta1 : 15.471 MHz : -0.142 dB T1 : 5732.856 MHz : -8.063 dBm T2 : 5757.064 MHz : -9.602 dBm OBW : 24.208 MHz	Measured 6 dB Bandwidth: 15.471 MHz Limit: ≥500.0 kHz Margin: -14.97 MHz

[Back to the Matrix](#)

This test report may be reproduced in full only. The document may only be updated by MiCOM Labs personnel. Any changes will be noted in the Document History section of the report.



6 dB & 99% BANDWIDTH

Variant: 802.11a, Channel: 5785.00 MHz, Chain a, Temp: Ambient, Voltage: 3.6 Vdc

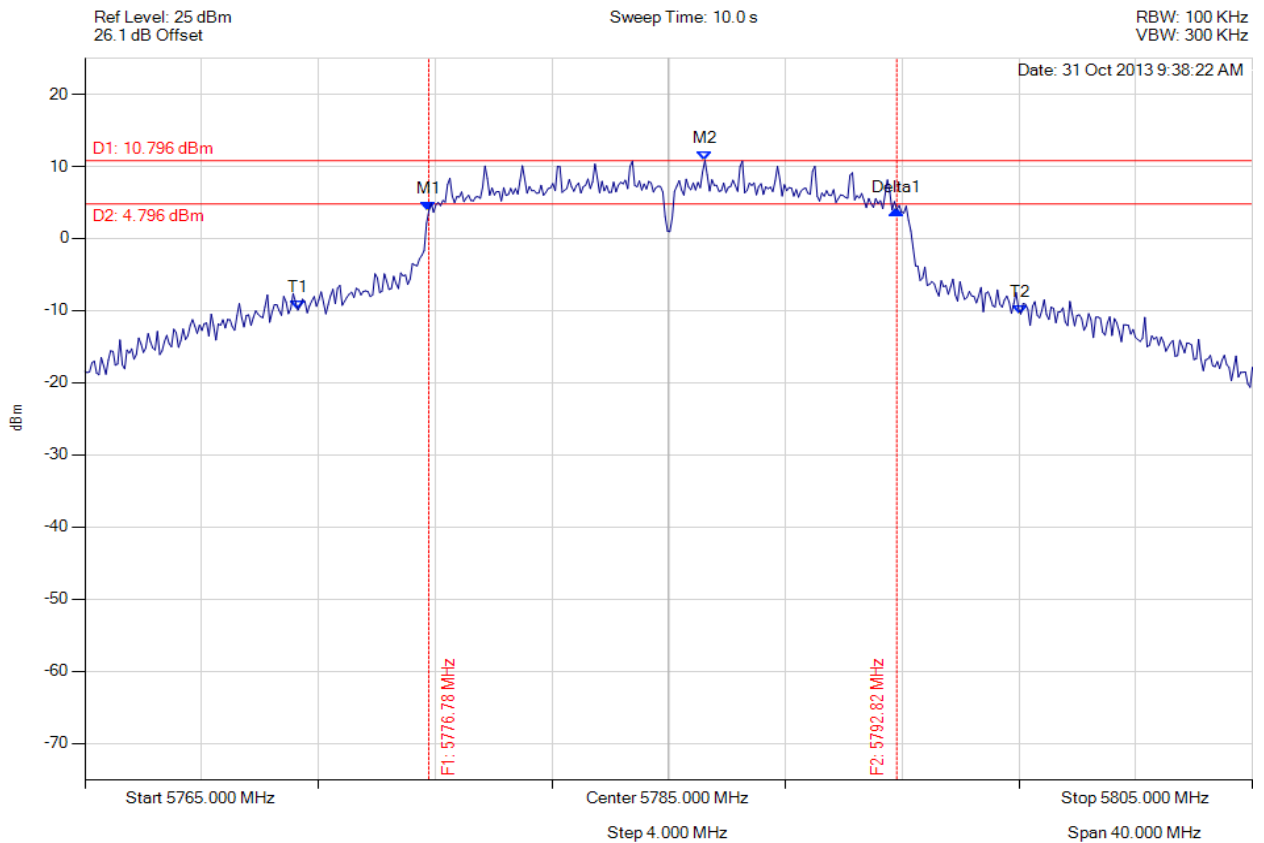

Analyser Setup	Marker : Frequency : Amplitude	Test Results
Detector = MAX PEAK Sweep Count = 0 RF Atten (dB) = 20 Trace Mode = VIEW	M1 : 5776.784 MHz : 3.778 dBm M2 : 5786.242 MHz : 10.796 dBm Delta1 : 16.032 MHz : 0.242 dB T1 : 5772.295 MHz : -9.932 dBm T2 : 5797.064 MHz : -10.471 dBm OBW : 24.770 MHz	Measured 6 dB Bandwidth: 16.032 MHz Limit: ≥ 500.0 kHz Margin: -15.53 MHz

[Back to the Matrix](#)

This test report may be reproduced in full only. The document may only be updated by MiCOM Labs personnel. Any changes will be noted in the Document History section of the report.

6 dB & 99% BANDWIDTH

Variant: 802.11a, Channel: 5825.00 MHz, Chain a, Temp: Ambient, Voltage: 3.6 Vdc

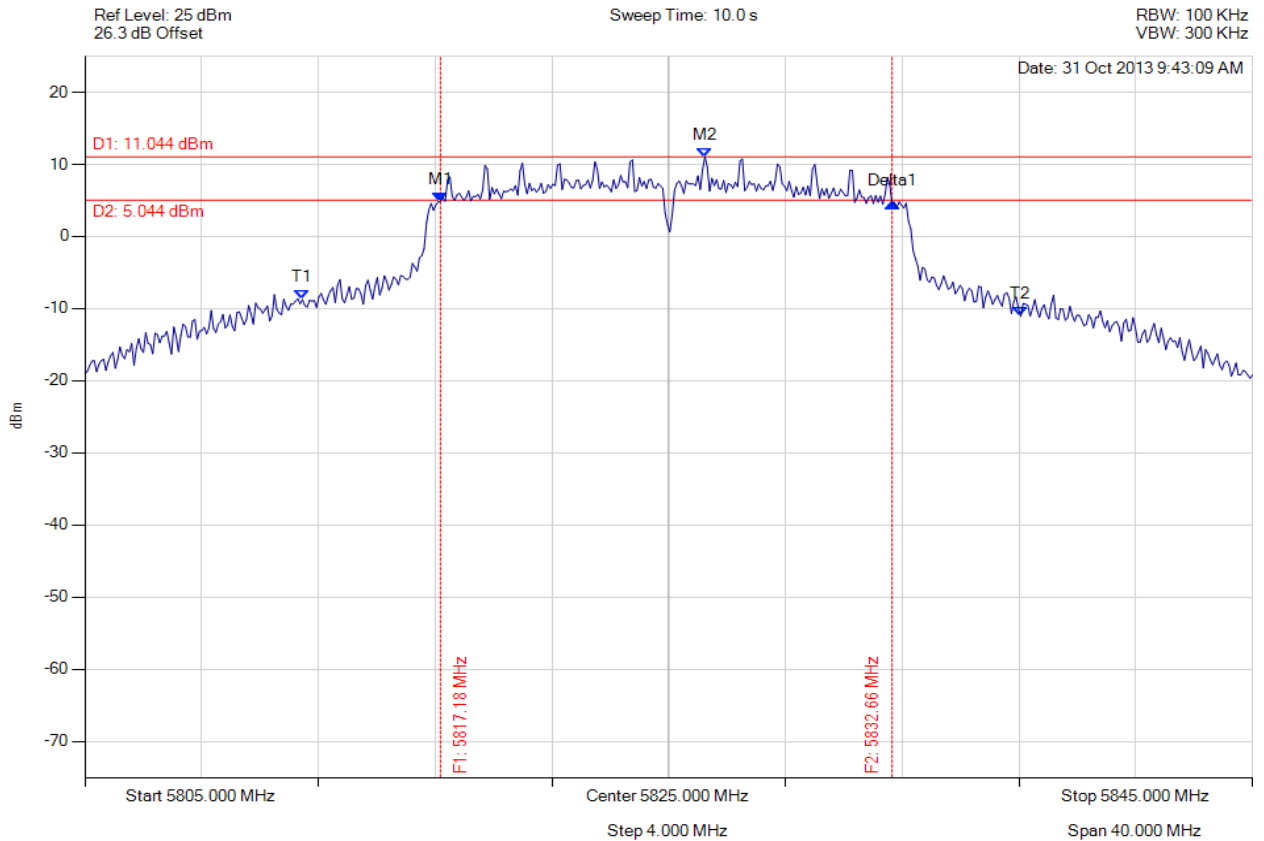

Analyser Setup	Marker : Frequency : Amplitude	Test Results
Detector = MAX PEAK Sweep Count = 0 RF Atten (dB) = 20 Trace Mode = VIEW	M1 : 5817.184 MHz : 4.872 dBm M2 : 5826.242 MHz : 11.044 dBm Delta1 : 15.471 MHz : -0.303 dB T1 : 5812.455 MHz : -8.758 dBm T2 : 5837.064 MHz : -11.050 dBm OBW : 24.609 MHz	Measured 6 dB Bandwidth: 15.471 MHz Limit: ≥500.0 kHz Margin: -14.97 MHz

[Back to the Matrix](#)

This test report may be reproduced in full only. The document may only be updated by MiCOM Labs personnel. Any changes will be noted in the Document History section of the report.



6 dB & 99% BANDWIDTH

Variant: 802.11n HT-20, Channel: 5745.00 MHz, Chain a, Temp: Ambient, Voltage: 3.6 Vdc

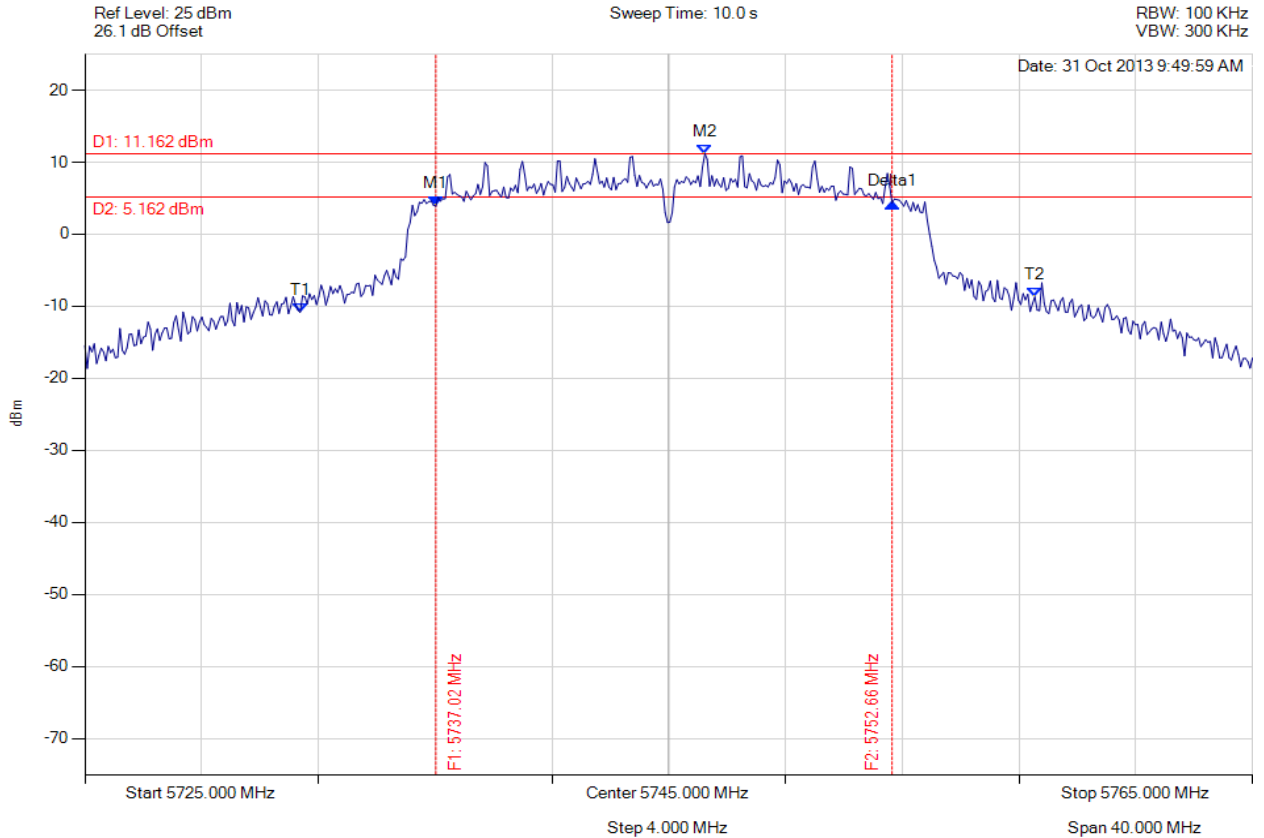

Analyser Setup	Marker : Frequency : Amplitude	Test Results
Detector = MAX PEAK Sweep Count = 0 RF Atten (dB) = 20 Trace Mode = VIEW	M1 : 5737.024 MHz : 3.912 dBm M2 : 5746.242 MHz : 11.162 dBm Delta1 : 15.631 MHz : 0.443 dB T1 : 5732.375 MHz : -10.851 dBm T2 : 5757.545 MHz : -8.705 dBm OBW : 25.170 MHz	Measured 6 dB Bandwidth: 15.631 MHz Limit: ≥ 500.0 kHz Margin: -15.13 MHz

[Back to the Matrix](#)

This test report may be reproduced in full only. The document may only be updated by MiCOM Labs personnel. Any changes will be noted in the Document History section of the report.

6 dB & 99% BANDWIDTH

Variant: 802.11n HT-20, Channel: 5785.00 MHz, Chain a, Temp: Ambient, Voltage: 3.6 Vdc

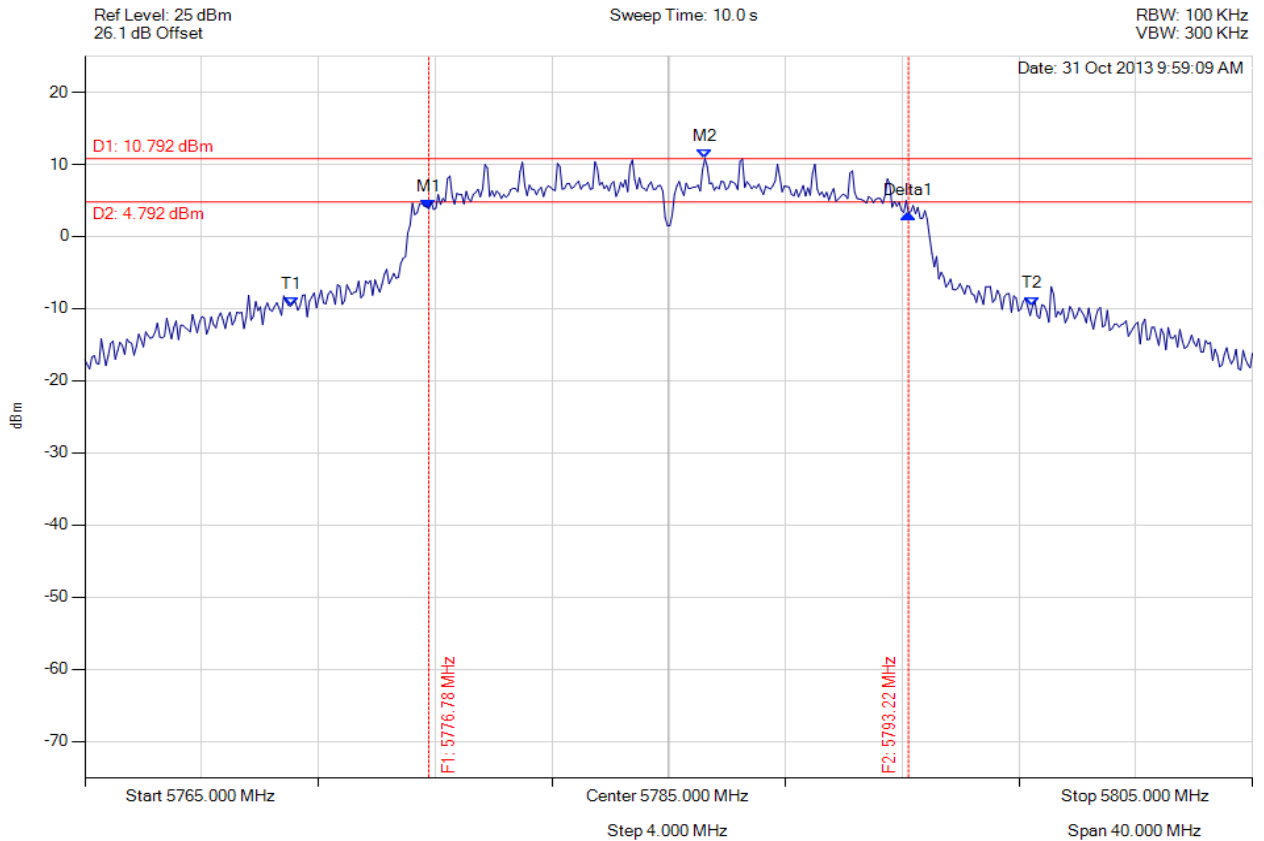

Analyser Setup	Marker : Frequency : Amplitude	Test Results
Detector = MAX PEAK Sweep Count = 0 RF Atten (dB) = 20 Trace Mode = VIEW	M1 : 5776.784 MHz : 3.788 dBm M2 : 5786.242 MHz : 10.792 dBm Delta1 : 16.433 MHz : -0.576 dB T1 : 5772.054 MHz : -9.637 dBm T2 : 5797.465 MHz : -9.629 dBm OBW : 25.411 MHz	Measured 6 dB Bandwidth: 16.433 MHz Limit: ≥ 500.0 kHz Margin: -15.93 MHz

[Back to the Matrix](#)

This test report may be reproduced in full only. The document may only be updated by MiCOM Labs personnel. Any changes will be noted in the Document History section of the report.

6 dB & 99% BANDWIDTH

Variant: 802.11n HT-20, Channel: 5825.00 MHz, Chain a, Temp: Ambient, Voltage: 3.6 Vdc

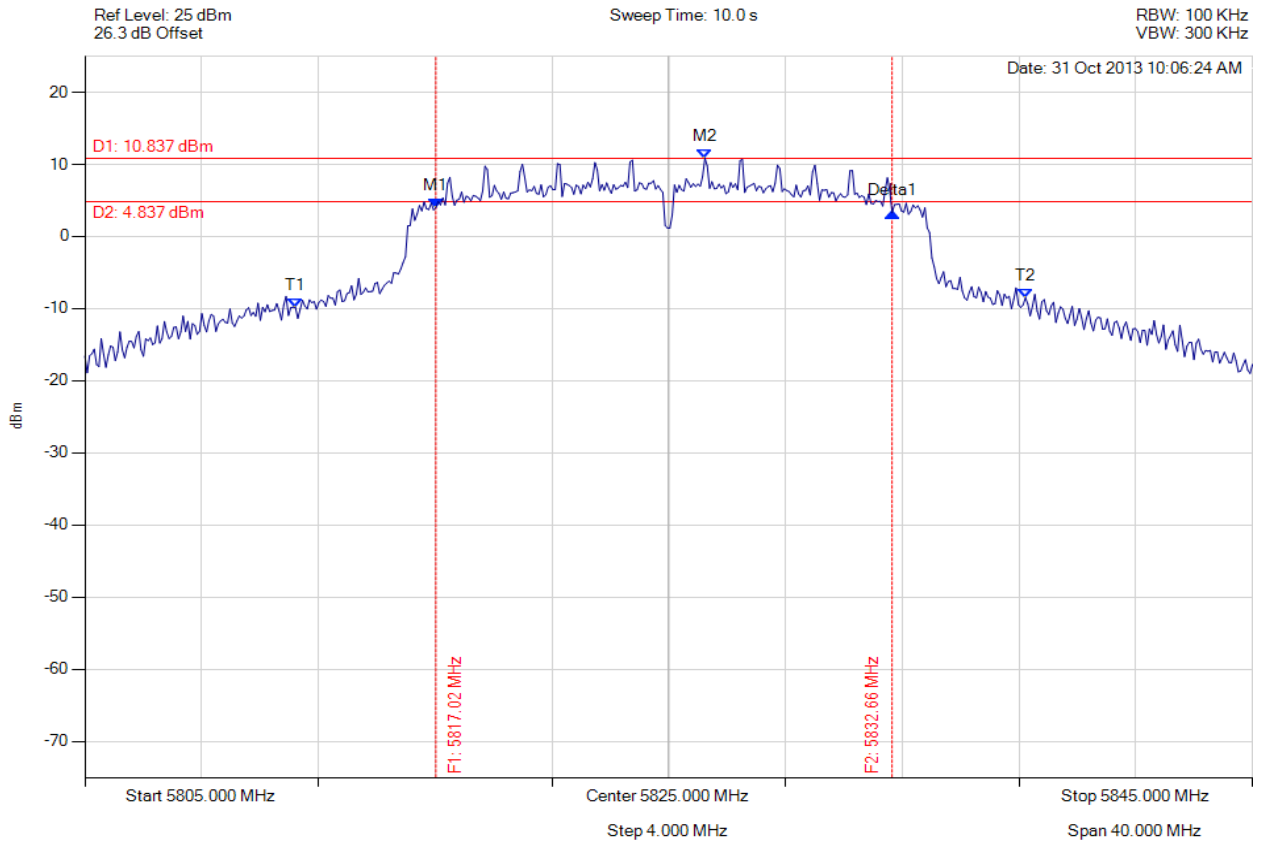

Analyser Setup	Marker : Frequency : Amplitude	Test Results
Detector = MAX PEAK Sweep Count = 0 RF Atten (dB) = 20 Trace Mode = VIEW	M1 : 5817.024 MHz : 3.977 dBm M2 : 5826.242 MHz : 10.837 dBm Delta1 : 15.631 MHz : -0.675 dB T1 : 5812.214 MHz : -9.852 dBm T2 : 5837.224 MHz : -8.496 dBm OBW : 25.010 MHz	Measured 6 dB Bandwidth: 15.631 MHz Limit: ≥500.0 kHz Margin: -15.13 MHz

[Back to the Matrix](#)

This test report may be reproduced in full only. The document may only be updated by MiCOM Labs personnel. Any changes will be noted in the Document History section of the report.



A.1.2. Peak Output Power



PEAK OUTPUT POWER

Variant: 802.11b, Channel: 2412.00 MHz, Chain a, Temp: Ambient, Voltage: 3.6 Vdc

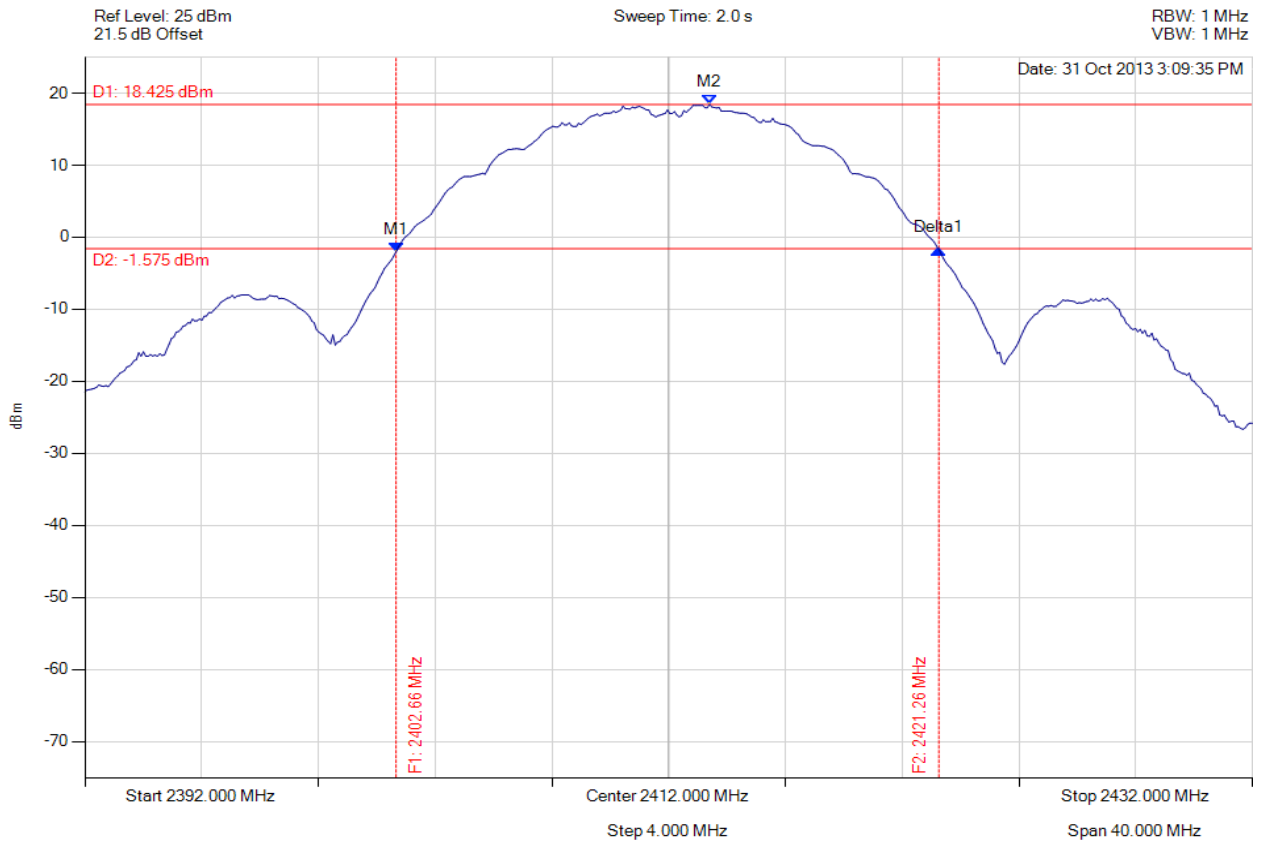

Analyser Setup	Marker : Frequency : Amplitude	Test Results
Detector = MAX PEAK Sweep Count = 0 RF Atten (dB) = 20 Trace Mode = VIEW	M1 : 2402.661 MHz : -2.028 dBm M2 : 2413.403 MHz : 18.425 dBm Delta1 : 18.597 MHz : 0.342 dB	Channel Power: 26.62 dBm Limit: 30.00 dBm Margin: -3.38 dB

[Back to the Matrix](#)

This test report may be reproduced in full only. The document may only be updated by MiCOM Labs personnel. Any changes will be noted in the Document History section of the report.



PEAK OUTPUT POWER

Variant: 802.11b, Channel: 2437.00 MHz, Chain a, Temp: Ambient, Voltage: 3.6 Vdc

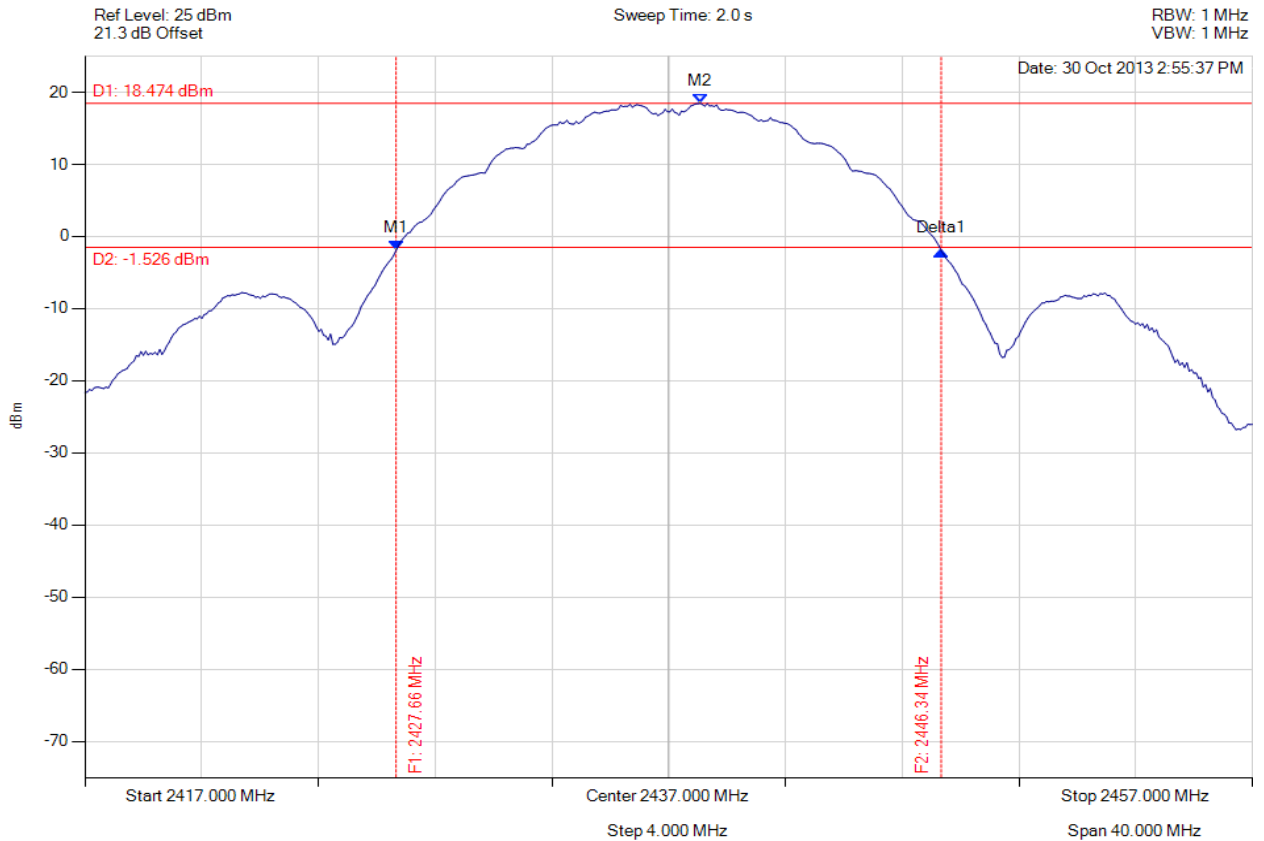

Analyser Setup	Marker : Frequency : Amplitude	Test Results
Detector = MAX PEAK Sweep Count = 0 RF Atten (dB) = 20 Trace Mode = VIEW	M1 : 2427.661 MHz : -1.904 dBm M2 : 2438.082 MHz : 18.474 dBm Delta1 : 18.677 MHz : -0.055 dB	Channel Power: 26.72 dBm Limit: 30.00 dBm Margin: -3.28 dB

[Back to the Matrix](#)

This test report may be reproduced in full only. The document may only be updated by MiCOM Labs personnel. Any changes will be noted in the Document History section of the report.



PEAK OUTPUT POWER

Variant: 802.11b, Channel: 2462.00 MHz, Chain a, Temp: Ambient, Voltage: 3.6 Vdc

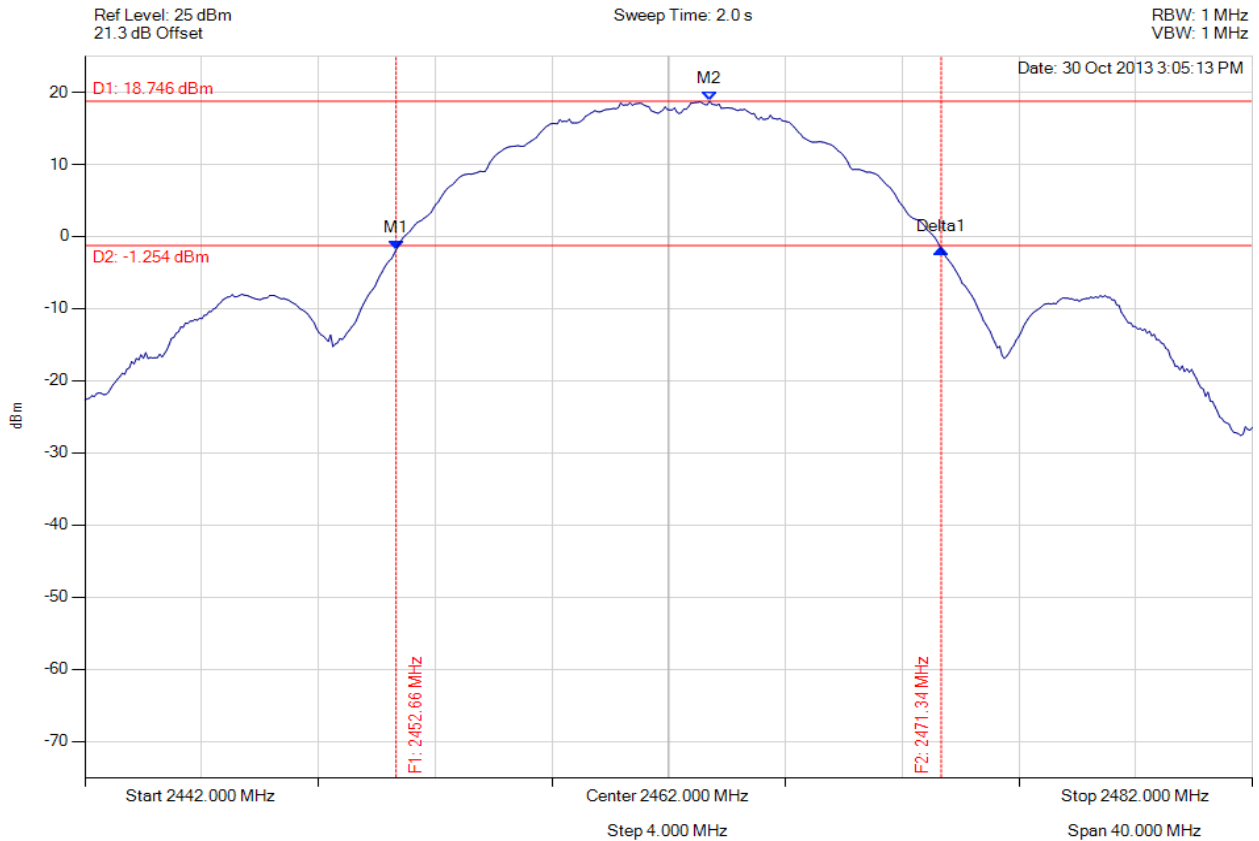

Analyser Setup	Marker : Frequency : Amplitude	Test Results
Detector = MAX PEAK Sweep Count = 0 RF Atten (dB) = 20 Trace Mode = VIEW	M1 : 2452.661 MHz : -1.837 dBm M2 : 2463.403 MHz : 18.746 dBm Delta1 : 18.677 MHz : 0.100 dB	Channel Power: 26.96 dBm Limit: 30.00 dBm Margin: -3.04 dB

[Back to the Matrix](#)

This test report may be reproduced in full only. The document may only be updated by MiCOM Labs personnel. Any changes will be noted in the Document History section of the report.



PEAK OUTPUT POWER

Variant: 802.11g, Channel: 2412.00 MHz, Chain a, Temp: Ambient, Voltage: 3.6 Vdc

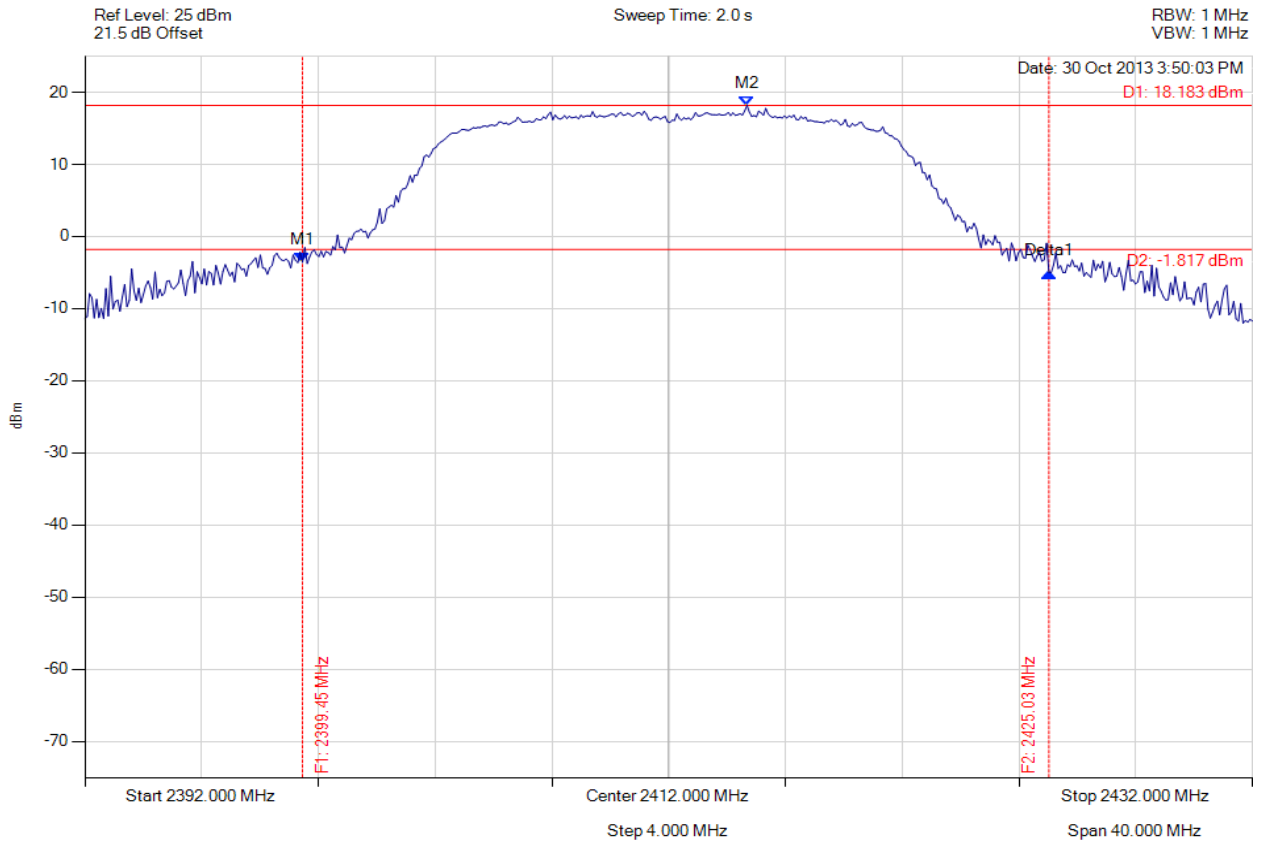

Analyser Setup	Marker : Frequency : Amplitude	Test Results
Detector = MAX PEAK Sweep Count = 0 RF Atten (dB) = 20 Trace Mode = VIEW	M1 : 2399.455 MHz : -3.572 dBm M2 : 2414.685 MHz : 18.183 dBm Delta1 : 25.571 MHz : -1.397 dB	Channel Power: 27.86 dBm Limit: 30.00 dBm Margin: -2.14 dB

[Back to the Matrix](#)

This test report may be reproduced in full only. The document may only be updated by MiCOM Labs personnel. Any changes will be noted in the Document History section of the report.



PEAK OUTPUT POWER

Variant: 802.11g, Channel: 2437.00 MHz, Chain a, Temp: Ambient, Voltage: 3.6 Vdc

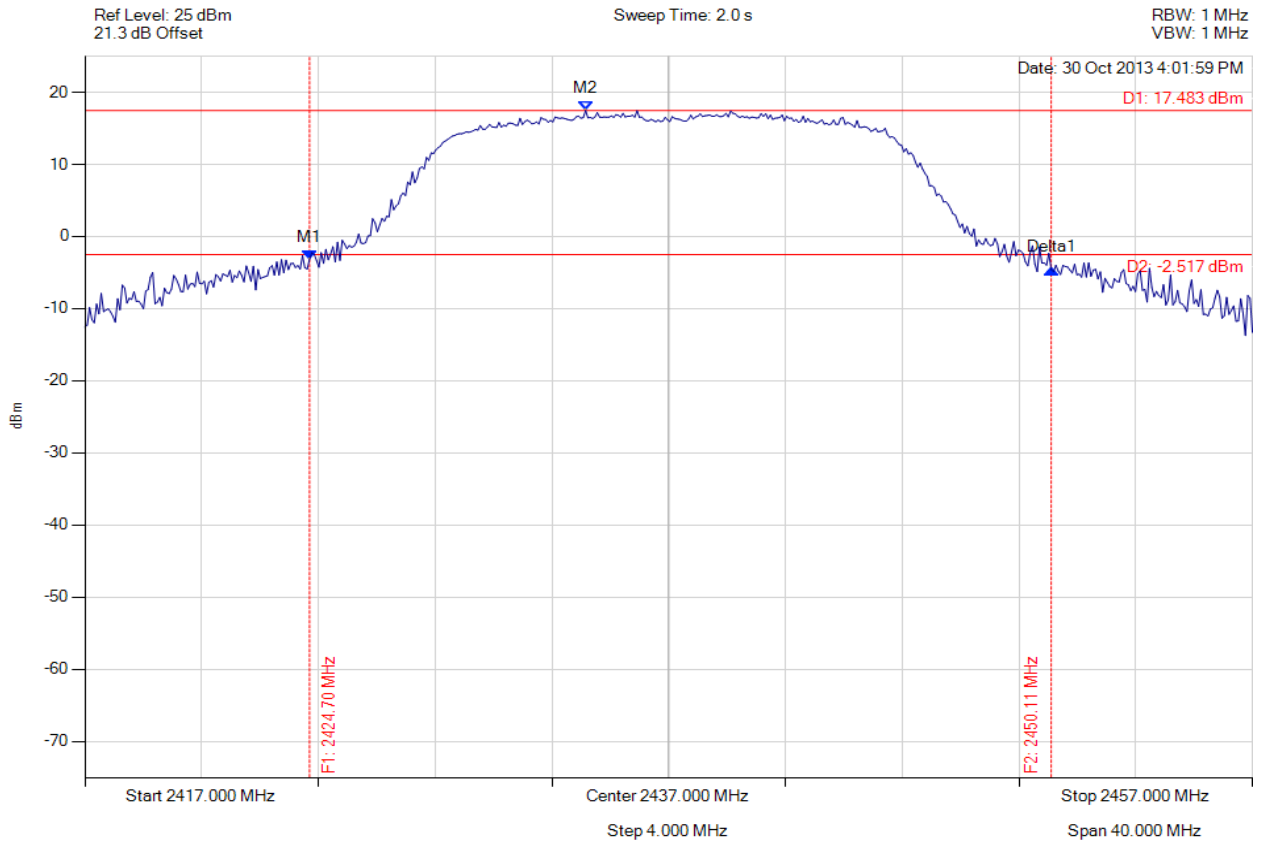

Analyser Setup	Marker : Frequency : Amplitude	Test Results
Detector = MAX PEAK Sweep Count = 0 RF Atten (dB) = 20 Trace Mode = VIEW	M1 : 2424.695 MHz : -3.163 dBm M2 : 2434.154 MHz : 17.483 dBm Delta1 : 25.411 MHz : -1.413 dB	Channel Power: 27.66 dBm Limit: 30.00 dBm Margin: -2.34 dB

[Back to the Matrix](#)

This test report may be reproduced in full only. The document may only be updated by MiCOM Labs personnel. Any changes will be noted in the Document History section of the report.



PEAK OUTPUT POWER

Variant: 802.11g, Channel: 2462.00 MHz, Chain a, Temp: Ambient, Voltage: 3.6 Vdc

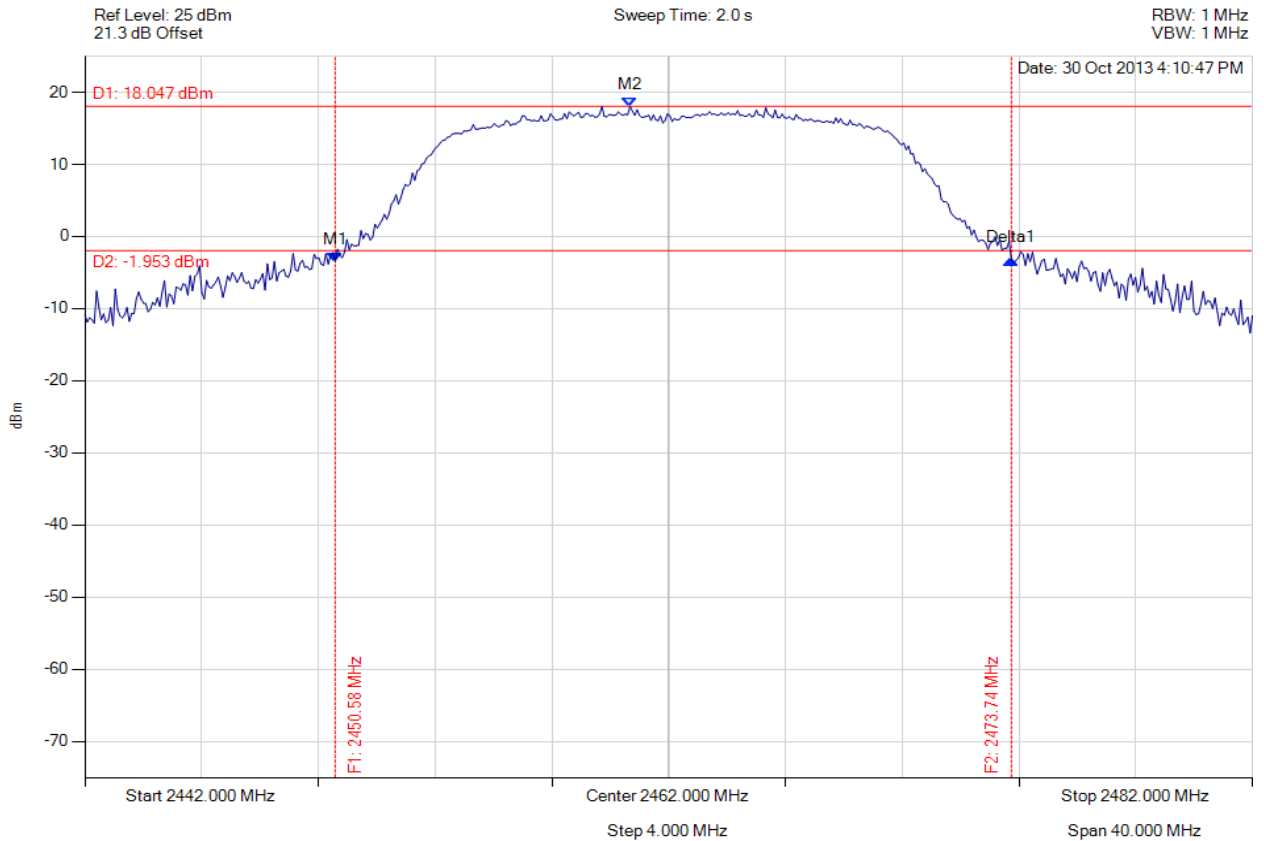

Analyser Setup	Marker : Frequency : Amplitude	Test Results
Detector = MAX PEAK Sweep Count = 0 RF Atten (dB) = 20 Trace Mode = VIEW	M1 : 2450.577 MHz : -3.491 dBm M2 : 2460.677 MHz : 18.047 dBm Delta1 : 23.166 MHz : 0.232 dB	Channel Power: 27.87 dBm Limit: 30.00 dBm Margin: -2.13 dB

[Back to the Matrix](#)

This test report may be reproduced in full only. The document may only be updated by MiCOM Labs personnel. Any changes will be noted in the Document History section of the report.



PEAK OUTPUT POWER

Variant: 802.11n HT-20, Channel: 2412.00 MHz, Chain a, Temp: Ambient, Voltage: 3.6 Vdc

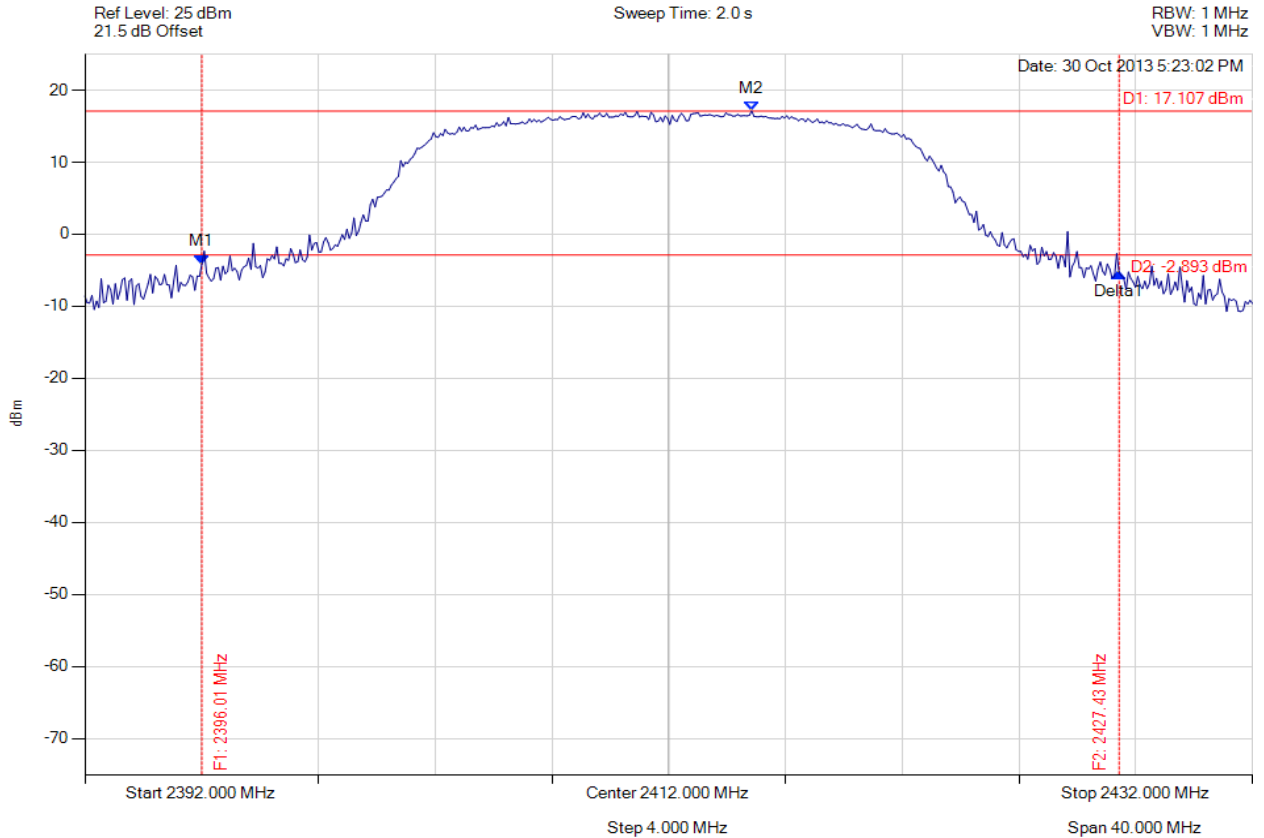

Analyser Setup	Marker : Frequency : Amplitude	Test Results
Detector = MAX PEAK Sweep Count = 0 RF Atten (dB) = 20 Trace Mode = VIEW	M1 : 2396.008 MHz : -4.121 dBm M2 : 2414.846 MHz : 17.107 dBm Delta1 : 31.423 MHz : -1.224 dB	Channel Power: 27.64 dBm Limit: 30.00 dBm Margin: -2.36 dB

[Back to the Matrix](#)

This test report may be reproduced in full only. The document may only be updated by MiCOM Labs personnel. Any changes will be noted in the Document History section of the report.



PEAK OUTPUT POWER

Variant: 802.11n HT-20, Channel: 2437.00 MHz, Chain a, Temp: Ambient, Voltage: 3.6 Vdc

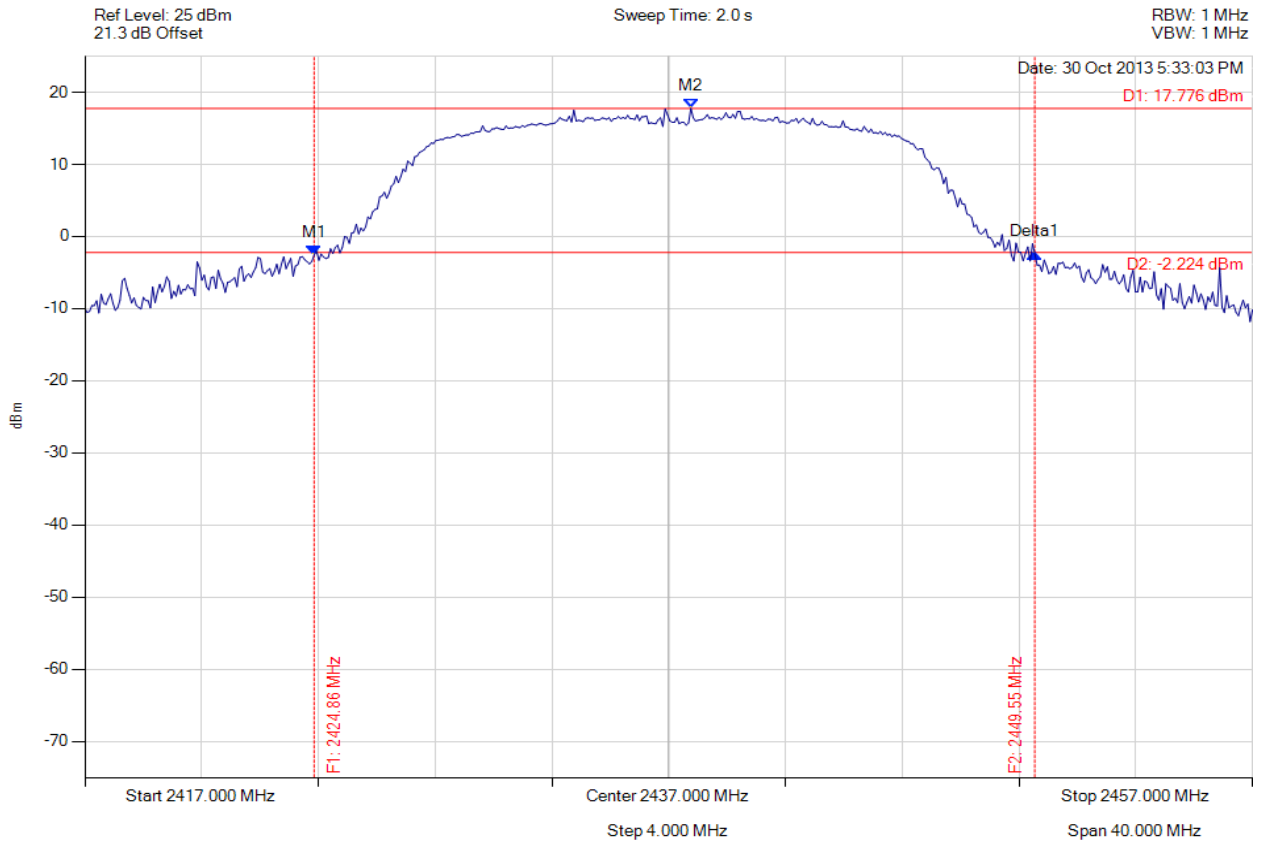

Analyser Setup	Marker : Frequency : Amplitude	Test Results
Detector = MAX PEAK Sweep Count = 0 RF Atten (dB) = 20 Trace Mode = VIEW	M1 : 2424.856 MHz : -2.557 dBm M2 : 2437.762 MHz : 17.776 dBm Delta1 : 24.689 MHz : 0.124 dB	Channel Power: 27.54 dBm Limit: 30.00 dBm Margin: -2.46 dB

[Back to the Matrix](#)

This test report may be reproduced in full only. The document may only be updated by MiCOM Labs personnel. Any changes will be noted in the Document History section of the report.



PEAK OUTPUT POWER

Variant: 802.11n HT-20, Channel: 2462.00 MHz, Chain a, Temp: Ambient, Voltage: 3.6 Vdc

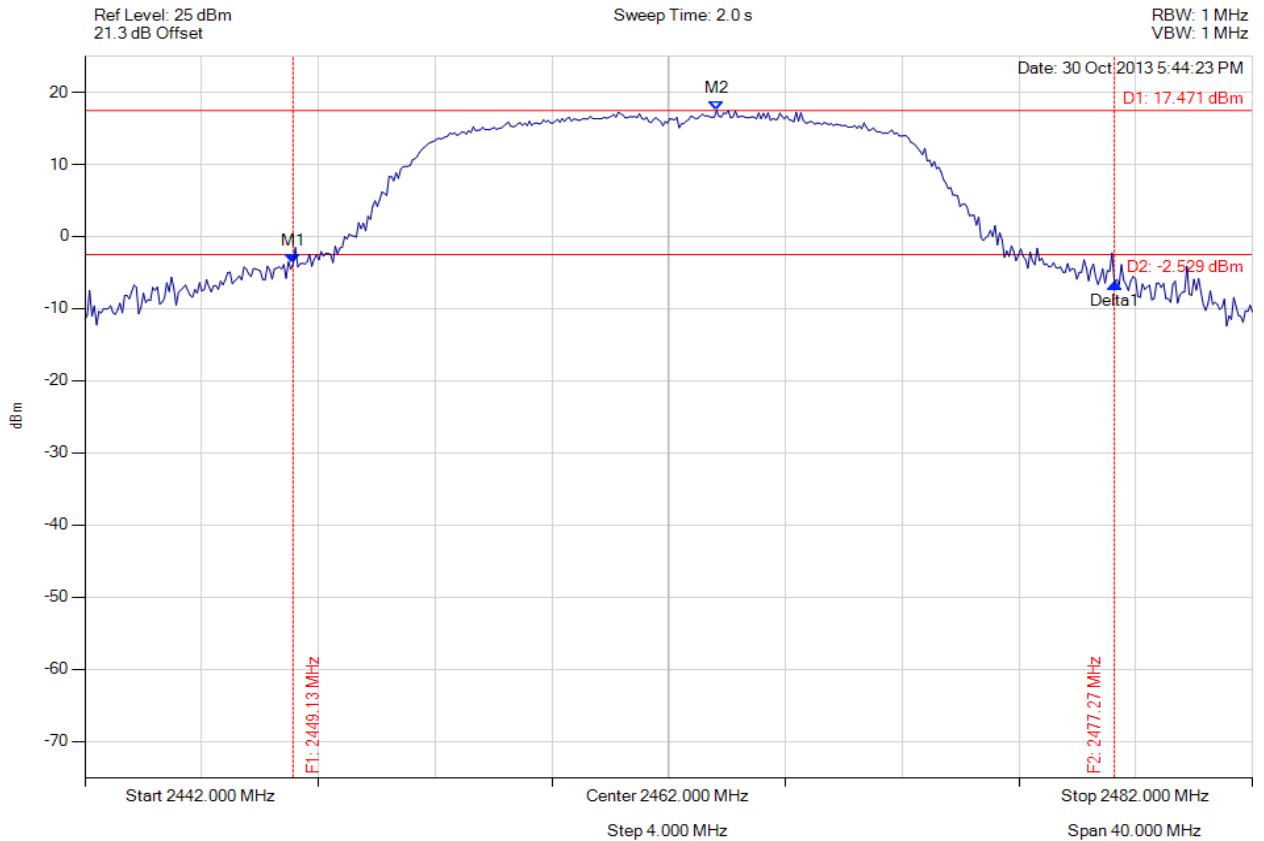

Analyser Setup	Marker : Frequency : Amplitude	Test Results
Detector = MAX PEAK Sweep Count = 0 RF Atten (dB) = 20 Trace Mode = VIEW	M1 : 2449.134 MHz : -3.763 dBm M2 : 2463.643 MHz : 17.471 dBm Delta1 : 28.136 MHz : -2.695 dB	Channel Power: 27.74 dBm Limit: 30.00 dBm Margin: -2.26 dB

[Back to the Matrix](#)

This test report may be reproduced in full only. The document may only be updated by MiCOM Labs personnel. Any changes will be noted in the Document History section of the report.



PEAK OUTPUT POWER

Variant: 802.11a, Channel: 5745.00 MHz, Chain a, Temp: Ambient, Voltage: 3.6 Vdc

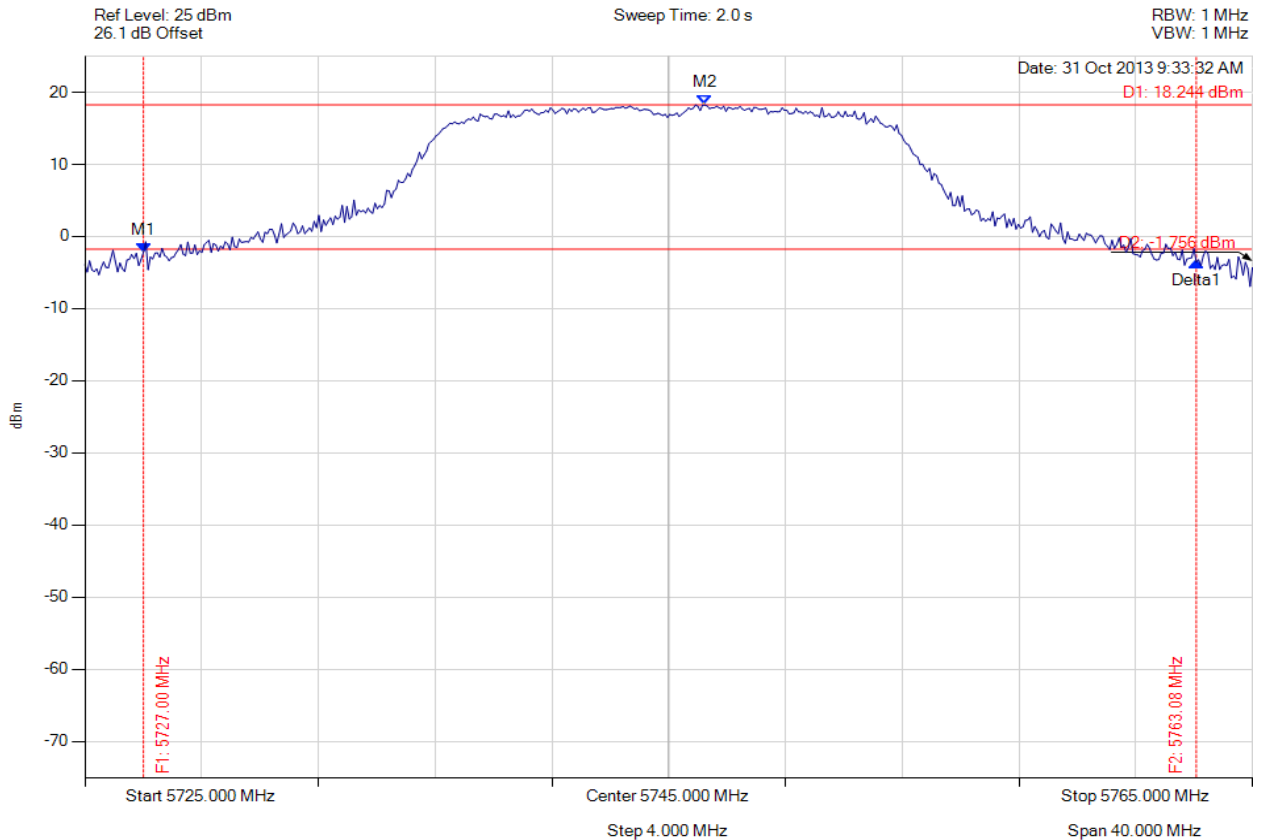

Analyser Setup	Marker : Frequency : Amplitude	Test Results
Detector = MAX PEAK Sweep Count = 0 RF Atten (dB) = 20 Trace Mode = VIEW	M1 : 5727.004 MHz : -2.179 dBm M2 : 5746.242 MHz : 18.244 dBm Delta1 : 36.072 MHz : -1.391 dB	Channel Power: 28.88 dBm Limit: 30.00 dBm Margin: -1.12 dB

[Back to the Matrix](#)

This test report may be reproduced in full only. The document may only be updated by MiCOM Labs personnel. Any changes will be noted in the Document History section of the report.



PEAK OUTPUT POWER

Variant: 802.11a, Channel: 5785.00 MHz, Chain a, Temp: Ambient, Voltage: 3.6 Vdc

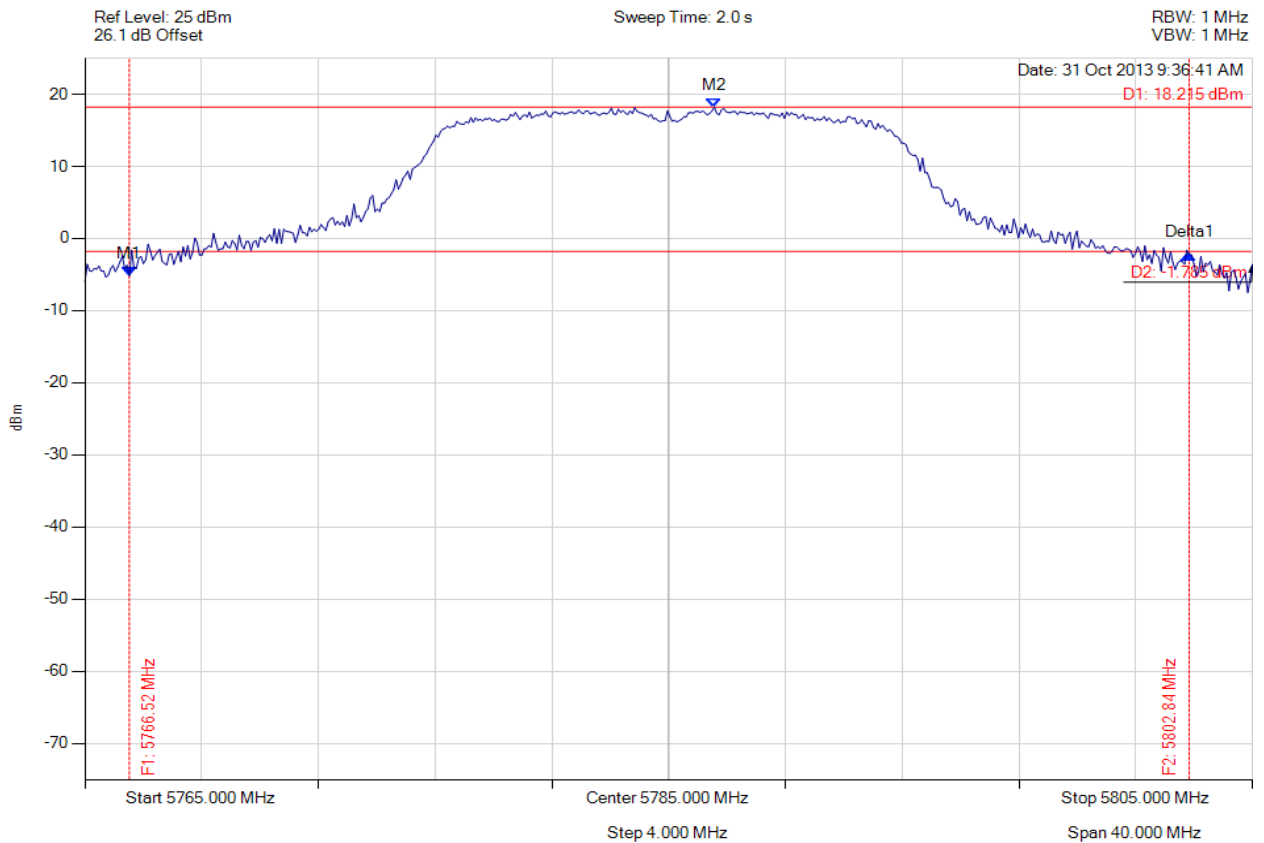

Analyser Setup	Marker : Frequency : Amplitude	Test Results
Detector = MAX PEAK Sweep Count = 0 RF Atten (dB) = 20 Trace Mode = VIEW	M1 : 5766.523 MHz : -5.217 dBm M2 : 5786.563 MHz : 18.215 dBm Delta1 : 36.313 MHz : 3.018 dB	Channel Power: 28.64 dBm Limit: 30.00 dBm Margin: -1.36 dB

[Back to the Matrix](#)

This test report may be reproduced in full only. The document may only be updated by MiCOM Labs personnel. Any changes will be noted in the Document History section of the report.



PEAK OUTPUT POWER

Variant: 802.11a, Channel: 5825.00 MHz, Chain a, Temp: Ambient, Voltage: 3.6 Vdc

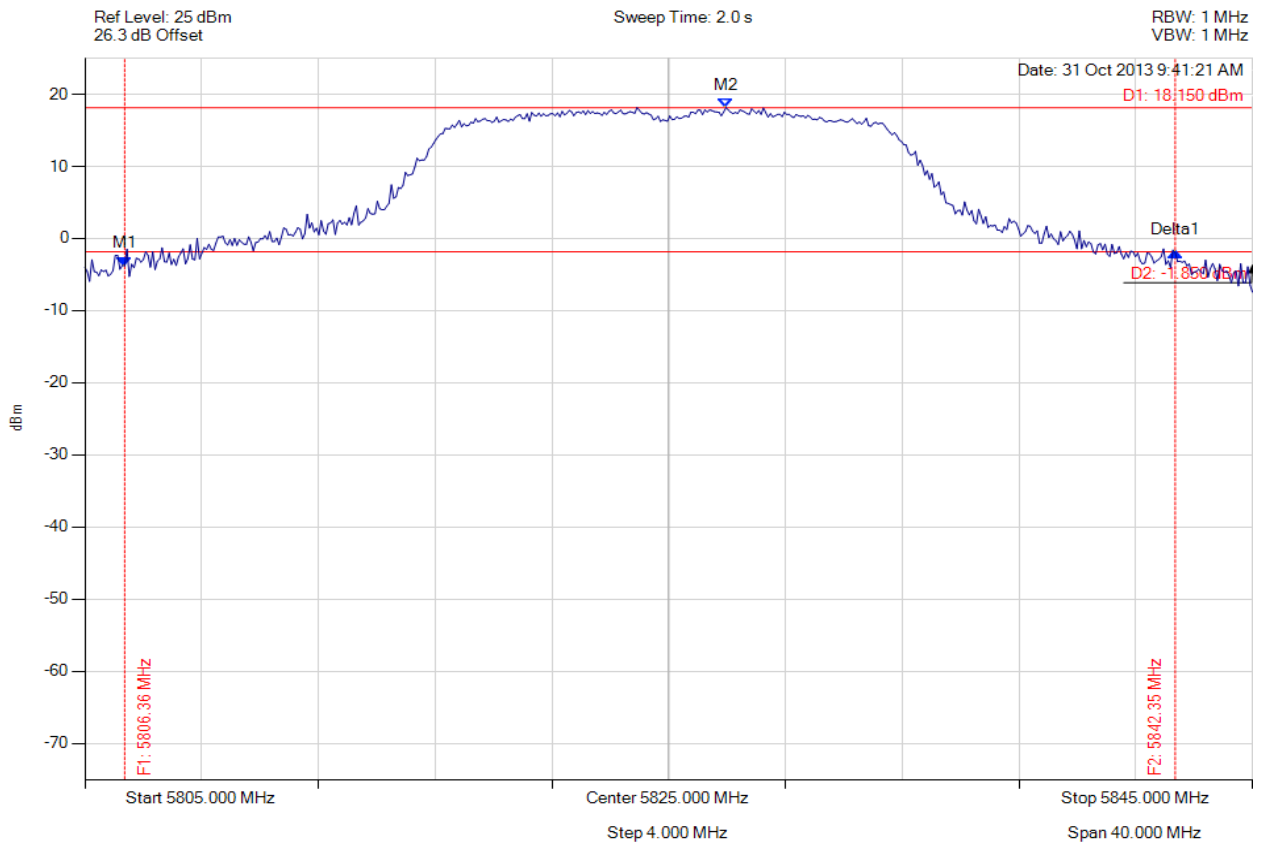

Analyser Setup	Marker : Frequency : Amplitude	Test Results
Detector = MAX PEAK Sweep Count = 0 RF Atten (dB) = 20 Trace Mode = VIEW	M1 : 5806.363 MHz : -3.786 dBm M2 : 5826.964 MHz : 18.150 dBm Delta1 : 35.992 MHz : 1.893 dB	Channel Power: 28.62 dBm Limit: 30.00 dBm Margin: -1.38 dB

[Back to the Matrix](#)

This test report may be reproduced in full only. The document may only be updated by MiCOM Labs personnel. Any changes will be noted in the Document History section of the report.



PEAK OUTPUT POWER

Variant: 802.11n HT-20, Channel: 5745.00 MHz, Chain a, Temp: Ambient, Voltage: 3.6 Vdc

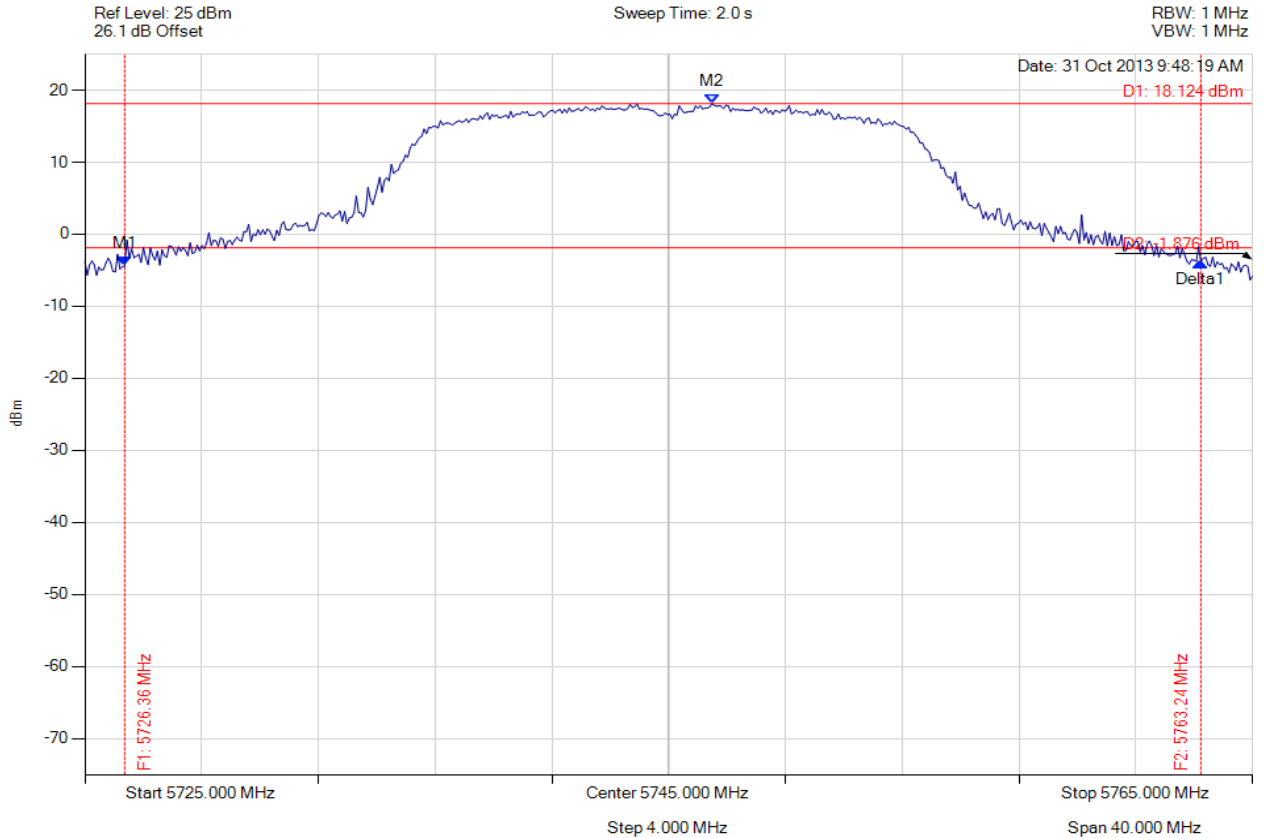

Analyser Setup	Marker : Frequency : Amplitude	Test Results
Detector = MAX PEAK Sweep Count = 0 RF Atten (dB) = 20 Trace Mode = VIEW	M1 : 5726.363 MHz : -4.420 dBm M2 : 5746.483 MHz : 18.124 dBm Delta1 : 36.874 MHz : 0.620 dB	Channel Power: 28.74 dBm Limit: 30.00 dBm Margin: -1.26 dB

[Back to the Matrix](#)

This test report may be reproduced in full only. The document may only be updated by MiCOM Labs personnel. Any changes will be noted in the Document History section of the report.



PEAK OUTPUT POWER

Variant: 802.11n HT-20, Channel: 5785.00 MHz, Chain a, Temp: Ambient, Voltage: 3.6 Vdc

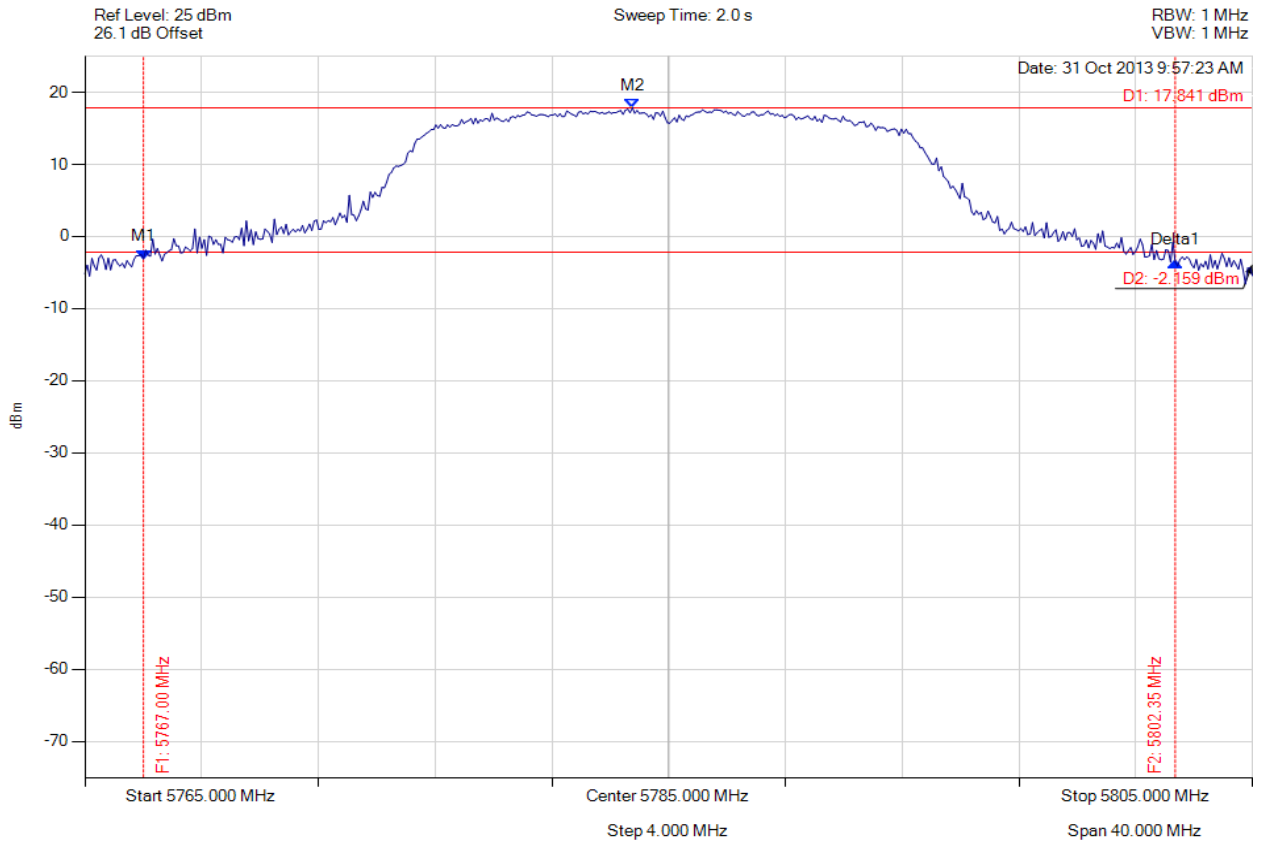

Analyser Setup	Marker : Frequency : Amplitude	Test Results
Detector = MAX PEAK Sweep Count = 0 RF Atten (dB) = 20 Trace Mode = VIEW	M1 : 5767.004 MHz : -3.123 dBm M2 : 5783.758 MHz : 17.841 dBm Delta1 : 35.351 MHz : -0.386 dB	Channel Power: 28.52 dBm Limit: 30.00 dBm Margin: -1.48 dB

[Back to the Matrix](#)

This test report may be reproduced in full only. The document may only be updated by MiCOM Labs personnel. Any changes will be noted in the Document History section of the report.



Title: Spectralink 8741 Basic IP Telephone
To: FCC 47 CFR Part 15.247 & IC RSS-210
Serial #: SPEC27-U4 Rev A
Issue Date: 1st January 2014
Page: 113 of 154



PEAK OUTPUT POWER

Variant: 802.11n HT-20, Channel: 5825.00 MHz, Chain a, Temp: Ambient, Voltage: 3.6 Vdc

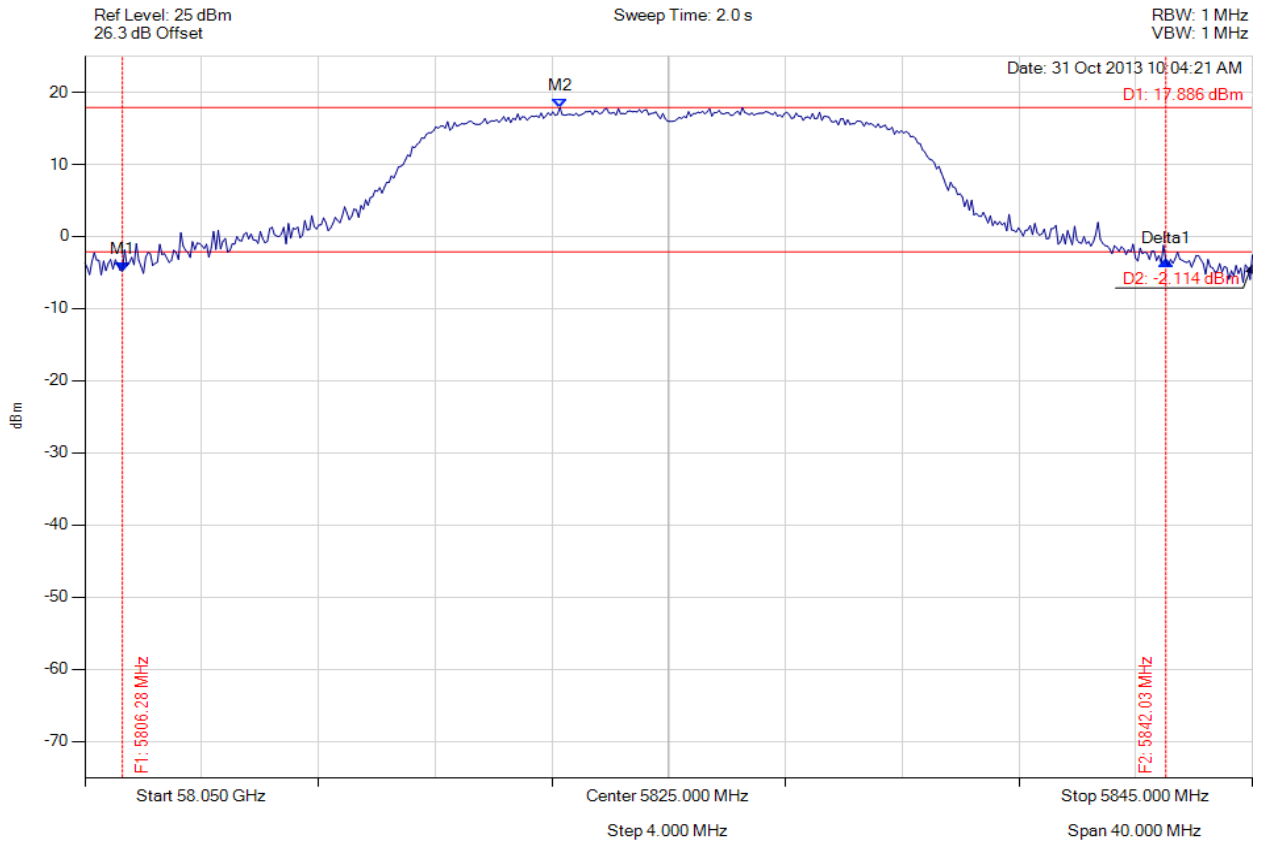

Analyser Setup	Marker : Frequency : Amplitude	Test Results
Detector = MAX PEAK Sweep Count = 0 RF Atten (dB) = 20 Trace Mode = VIEW	M1 : 5806.283 MHz : -4.803 dBm M2 : 5821.273 MHz : 17.886 dBm Delta1 : 35.752 MHz : 1.405 dB	Channel Power: 28.49 dBm Limit: 30.00 dBm Margin: -1.51 dB

[Back to the Matrix](#)

This test report may be reproduced in full only. The document may only be updated by MiCOM Labs personnel. Any changes will be noted in the Document History section of the report.



A.1.3. Power Spectral Density



POWER SPECTRAL DENSITY - PEAK

Variant: 802.11b, Channel: 2412.00 MHz, Chain a, Temp: Ambient, Voltage: 3.6 Vdc

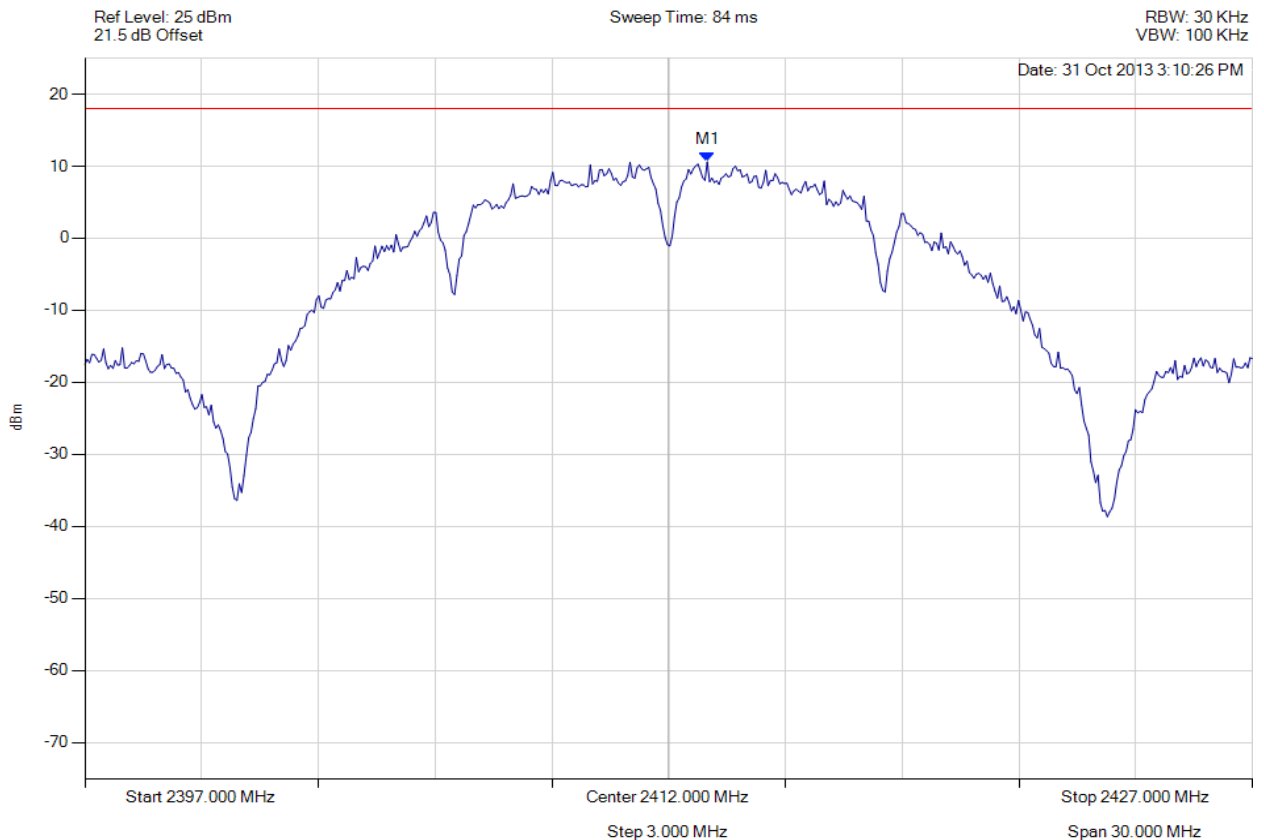

Analyser Setup	Marker : Frequency : Amplitude	Test Results
Detector = MAX PEAK Sweep Count = 0 RF Atten (dB) = 20 Trace Mode = VIEW	M1 : 2412.992 MHz : 10.595 dBm	Limit: ≤ 18.000 dBm Margin: -7.40 dB

[Back to the Matrix](#)

This test report may be reproduced in full only. The document may only be updated by MiCOM Labs personnel. Any changes will be noted in the Document History section of the report.



POWER SPECTRAL DENSITY - PEAK

Variant: 802.11b, Channel: 2437.00 MHz, Chain a, Temp: Ambient, Voltage: 3.6 Vdc

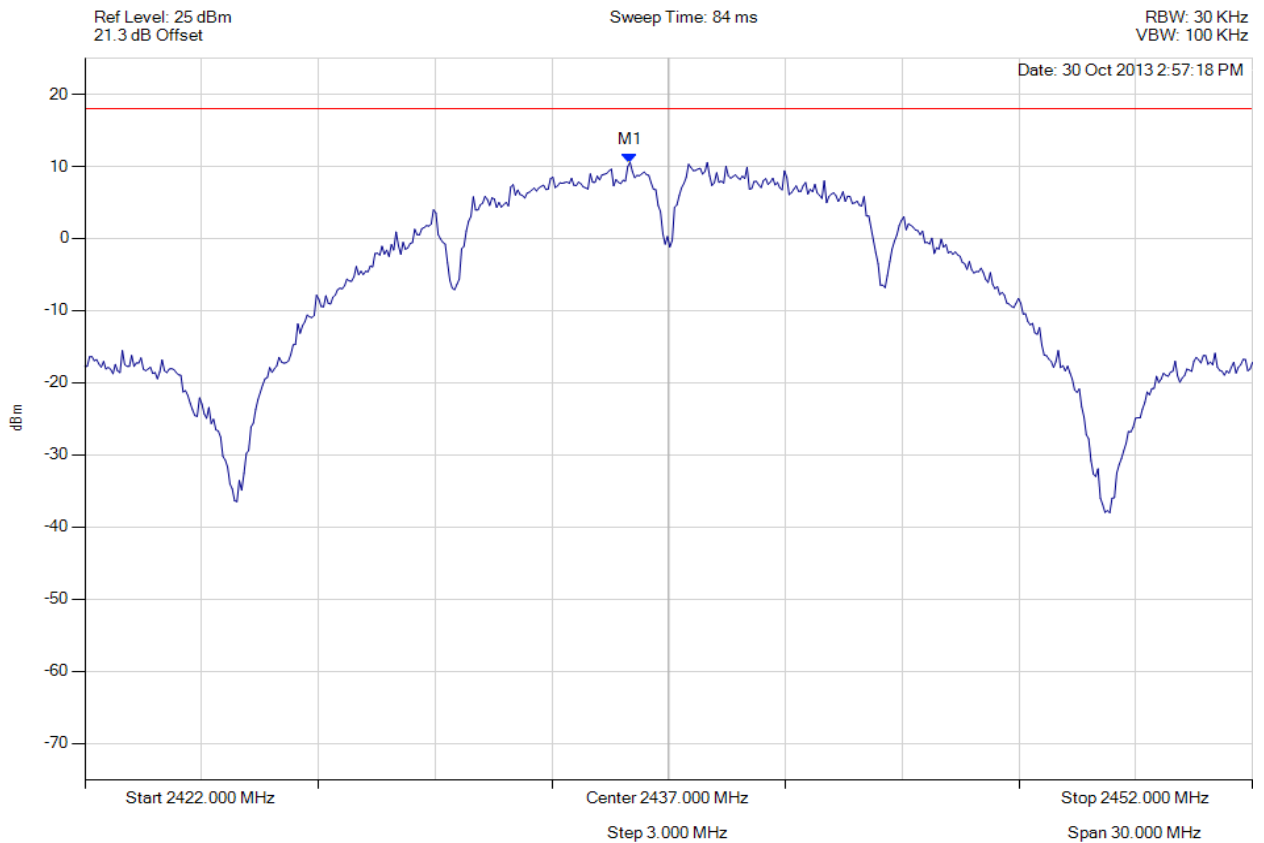

Analyser Setup	Marker : Frequency : Amplitude	Test Results
Detector = MAX PEAK Sweep Count = 0 RF Atten (dB) = 20 Trace Mode = VIEW	M1 : 2436.008 MHz : 10.560 dBm	Limit: ≤ 18.000 dBm Margin: -7.44 dB

[Back to the Matrix](#)

This test report may be reproduced in full only. The document may only be updated by MiCOM Labs personnel. Any changes will be noted in the Document History section of the report.



POWER SPECTRAL DENSITY - PEAK

Variant: 802.11b, Channel: 2462.00 MHz, Chain a, Temp: Ambient, Voltage: 3.6 Vdc

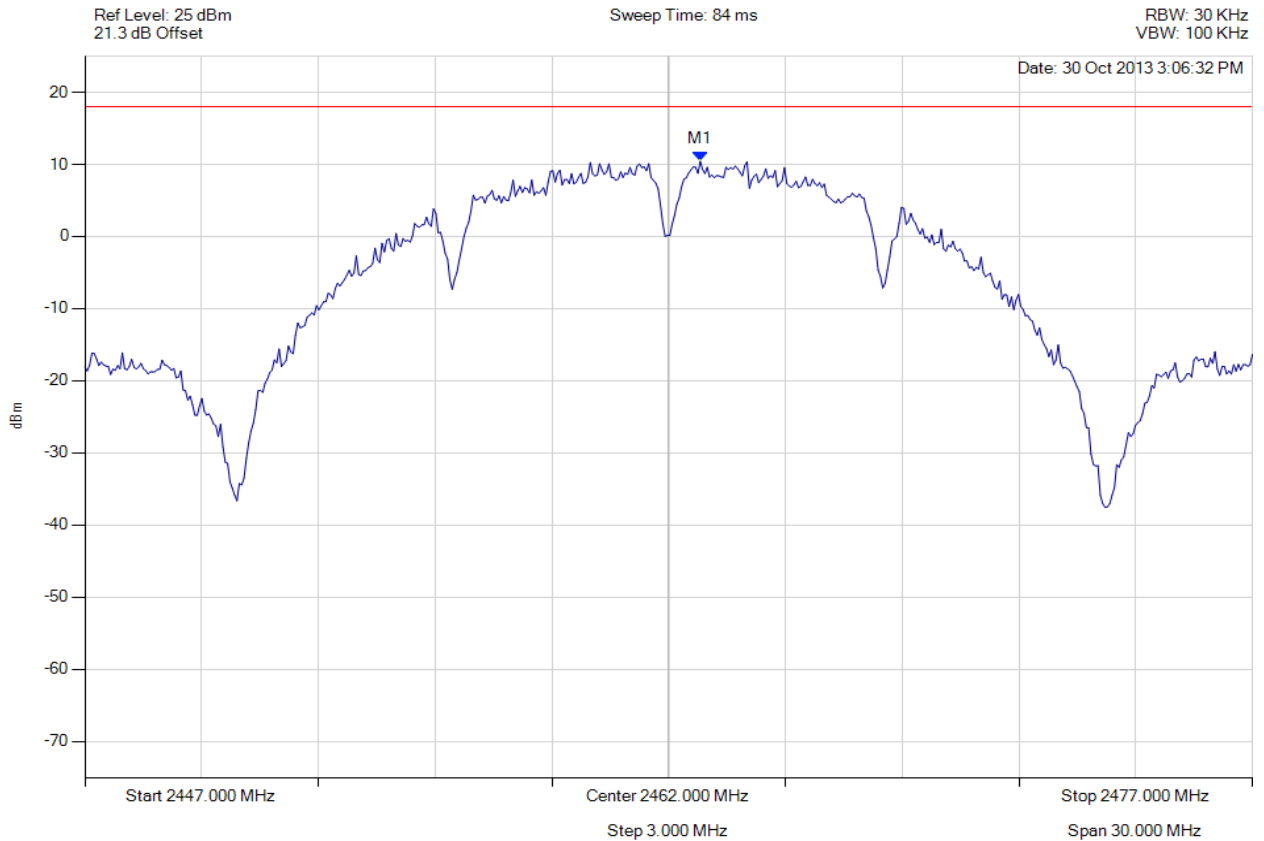

Analyser Setup	Marker : Frequency : Amplitude	Test Results
Detector = MAX PEAK Sweep Count = 0 RF Atten (dB) = 20 Trace Mode = VIEW	M1 : 2462.812 MHz : 10.418 dBm	Limit: ≤ 18.000 dBm Margin: -7.58 dB

[Back to the Matrix](#)

This test report may be reproduced in full only. The document may only be updated by MiCOM Labs personnel. Any changes will be noted in the Document History section of the report.



Title: Spectralink 8741 Basic IP Telephone
To: FCC 47 CFR Part 15.247 & IC RSS-210
Serial #: SPEC27-U4 Rev A
Issue Date: 1st January 2014
Page: 117 of 154



POWER SPECTRAL DENSITY - PEAK

Variant: 802.11g, Channel: 2412.00 MHz, Chain a, Temp: Ambient, Voltage: 3.6 Vdc

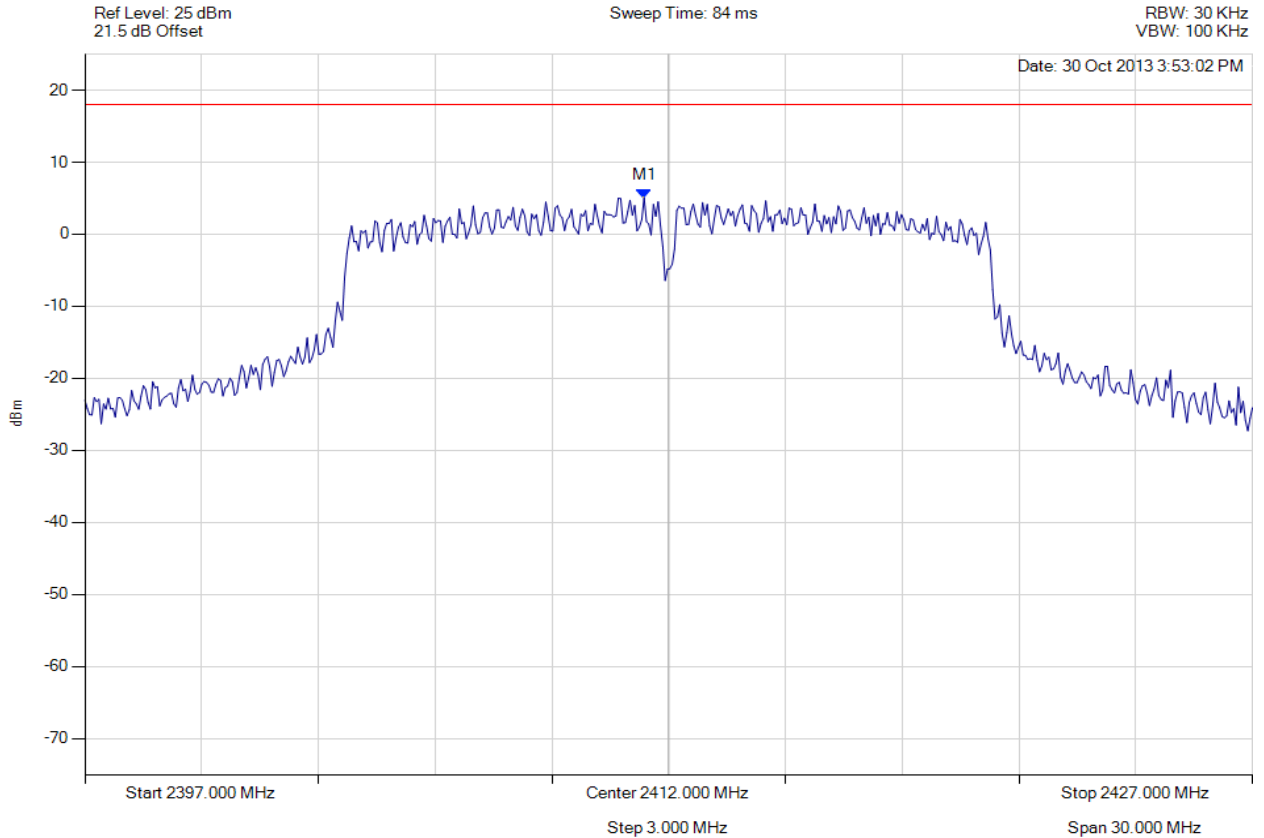

Analyser Setup	Marker : Frequency : Amplitude	Test Results
Detector = MAX PEAK Sweep Count = 0 RF Atten (dB) = 20 Trace Mode = VIEW	M1 : 2411.369 MHz : 5.055 dBm	Limit: ≤ 18.000 dBm Margin: -12.95 dB

[Back to the Matrix](#)

This test report may be reproduced in full only. The document may only be updated by MiCOM Labs personnel. Any changes will be noted in the Document History section of the report.



POWER SPECTRAL DENSITY - PEAK

Variant: 802.11g, Channel: 2437.00 MHz, Chain a, Temp: Ambient, Voltage: 3.6 Vdc

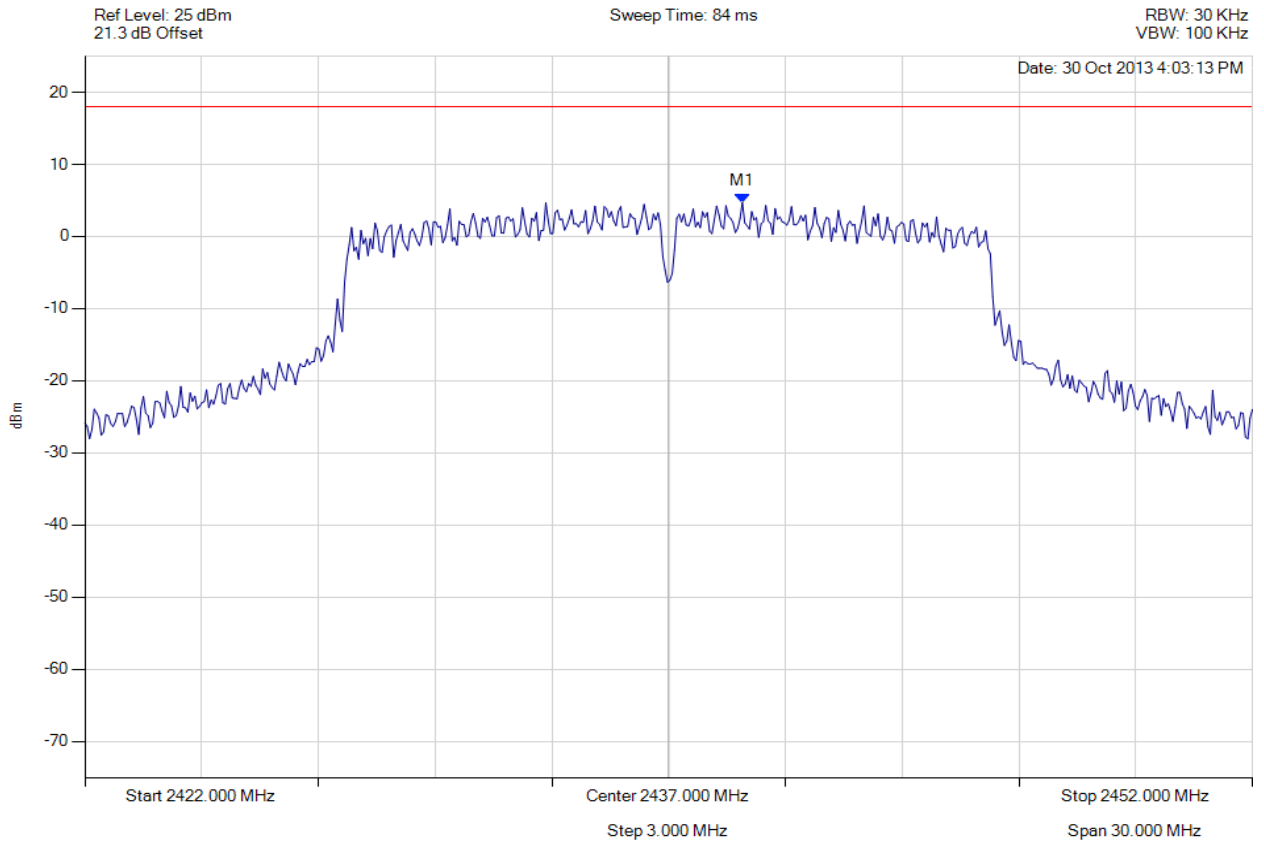

Analyser Setup	Marker : Frequency : Amplitude	Test Results
Detector = MAX PEAK Sweep Count = 0 RF Atten (dB) = 20 Trace Mode = VIEW	M1 : 2438.894 MHz : 4.697 dBm	Limit: ≤ 18.000 dBm Margin: -13.30 dB

[Back to the Matrix](#)

This test report may be reproduced in full only. The document may only be updated by MiCOM Labs personnel. Any changes will be noted in the Document History section of the report.



POWER SPECTRAL DENSITY - PEAK

Variant: 802.11g, Channel: 2462.00 MHz, Chain a, Temp: Ambient, Voltage: 3.6 Vdc

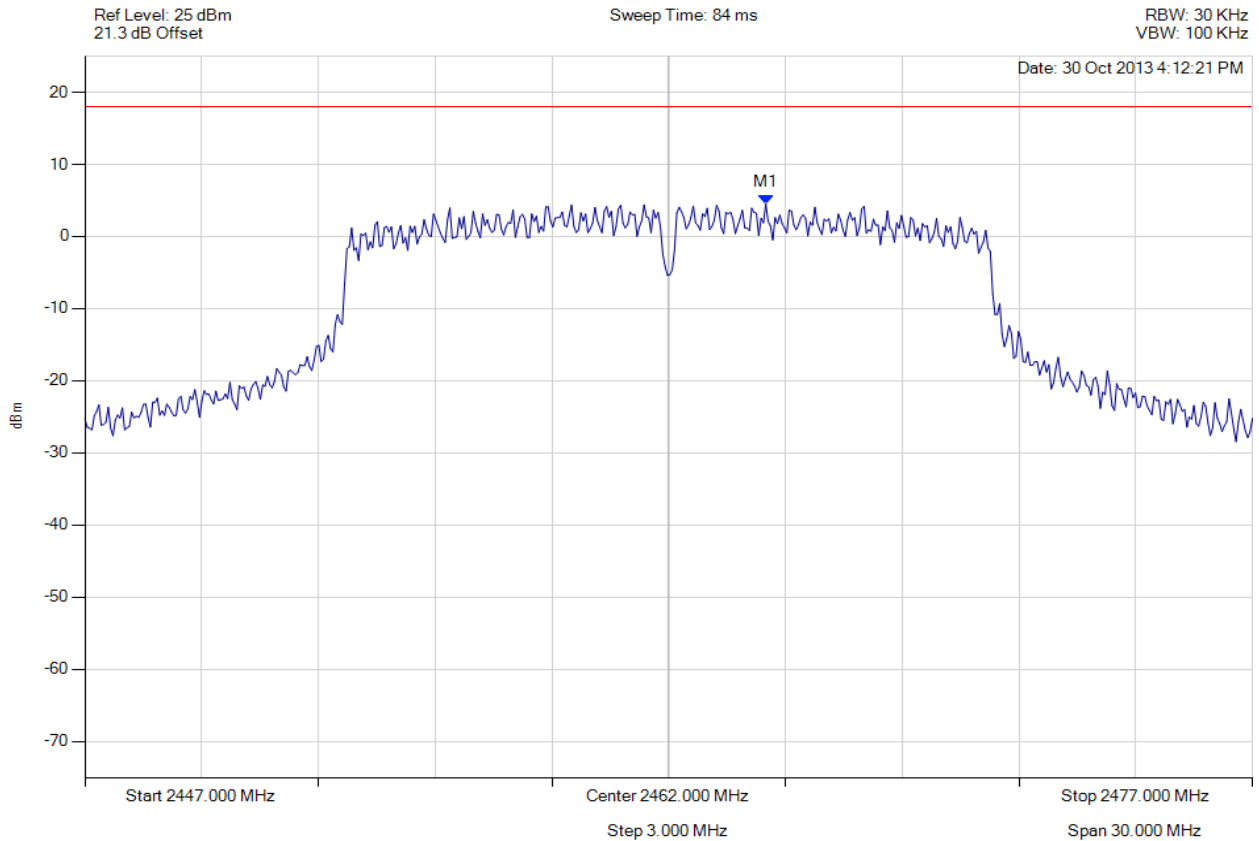

Analyser Setup	Marker : Frequency : Amplitude	Test Results
Detector = MAX PEAK Sweep Count = 0 RF Atten (dB) = 20 Trace Mode = VIEW	M1 : 2464.495 MHz : 4.512 dBm	Limit: ≤ 18.000 dBm Margin: -13.49 dB

[Back to the Matrix](#)

This test report may be reproduced in full only. The document may only be updated by MiCOM Labs personnel. Any changes will be noted in the Document History section of the report.



Title: Spectralink 8741 Basic IP Telephone
To: FCC 47 CFR Part 15.247 & IC RSS-210
Serial #: SPEC27-U4 Rev A
Issue Date: 1st January 2014
Page: 120 of 154



POWER SPECTRAL DENSITY - PEAK

Variant: 802.11n HT-20, Channel: 2412.00 MHz, Chain a, Temp: Ambient, Voltage: 3.6 Vdc

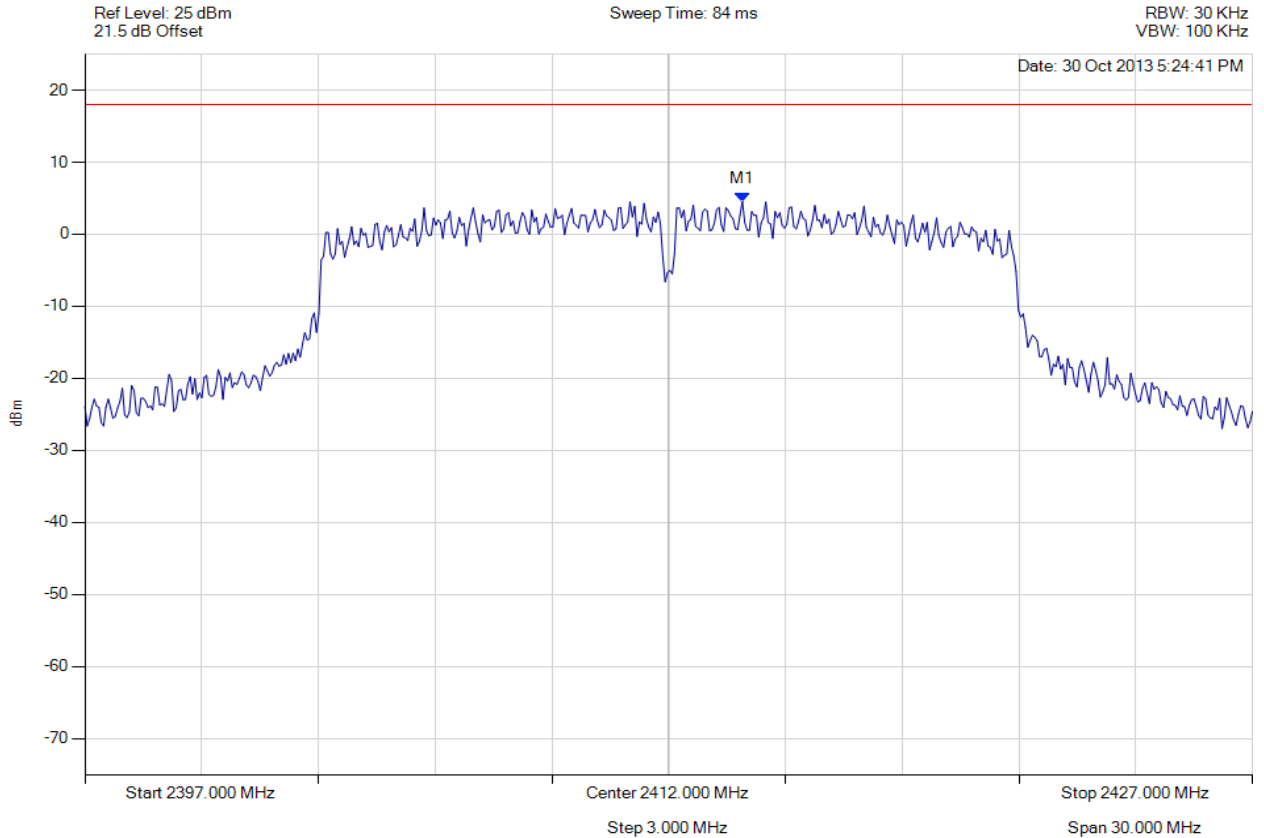

Analyser Setup	Marker : Frequency : Amplitude	Test Results
Detector = MAX PEAK Sweep Count = 0 RF Atten (dB) = 20 Trace Mode = VIEW	M1 : 2413.894 MHz : 4.549 dBm	Limit: ≤ 18.000 dBm Margin: -13.45 dB

[Back to the Matrix](#)

This test report may be reproduced in full only. The document may only be updated by MiCOM Labs personnel. Any changes will be noted in the Document History section of the report.



POWER SPECTRAL DENSITY - PEAK

Variant: 802.11n HT-20, Channel: 2437.00 MHz, Chain a, Temp: Ambient, Voltage: 3.6 Vdc

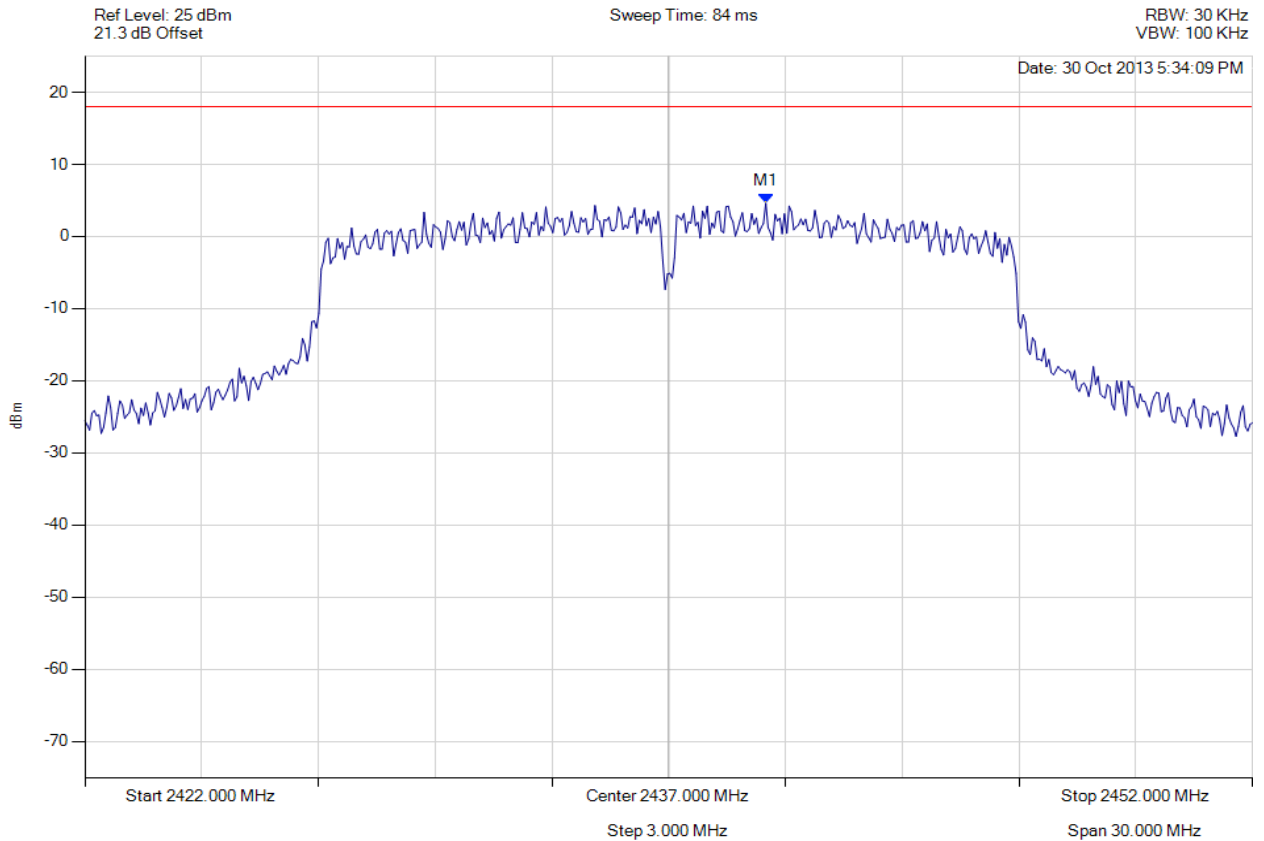

Analyser Setup	Marker : Frequency : Amplitude	Test Results
Detector = MAX PEAK Sweep Count = 0 RF Atten (dB) = 20 Trace Mode = VIEW	M1 : 2439.495 MHz : 4.612 dBm	Limit: ≤ 18.000 dBm Margin: -13.39 dB

[Back to the Matrix](#)

This test report may be reproduced in full only. The document may only be updated by MiCOM Labs personnel. Any changes will be noted in the Document History section of the report.



POWER SPECTRAL DENSITY - PEAK

Variant: 802.11n HT-20, Channel: 2462.00 MHz, Chain a, Temp: Ambient, Voltage: 3.6 Vdc

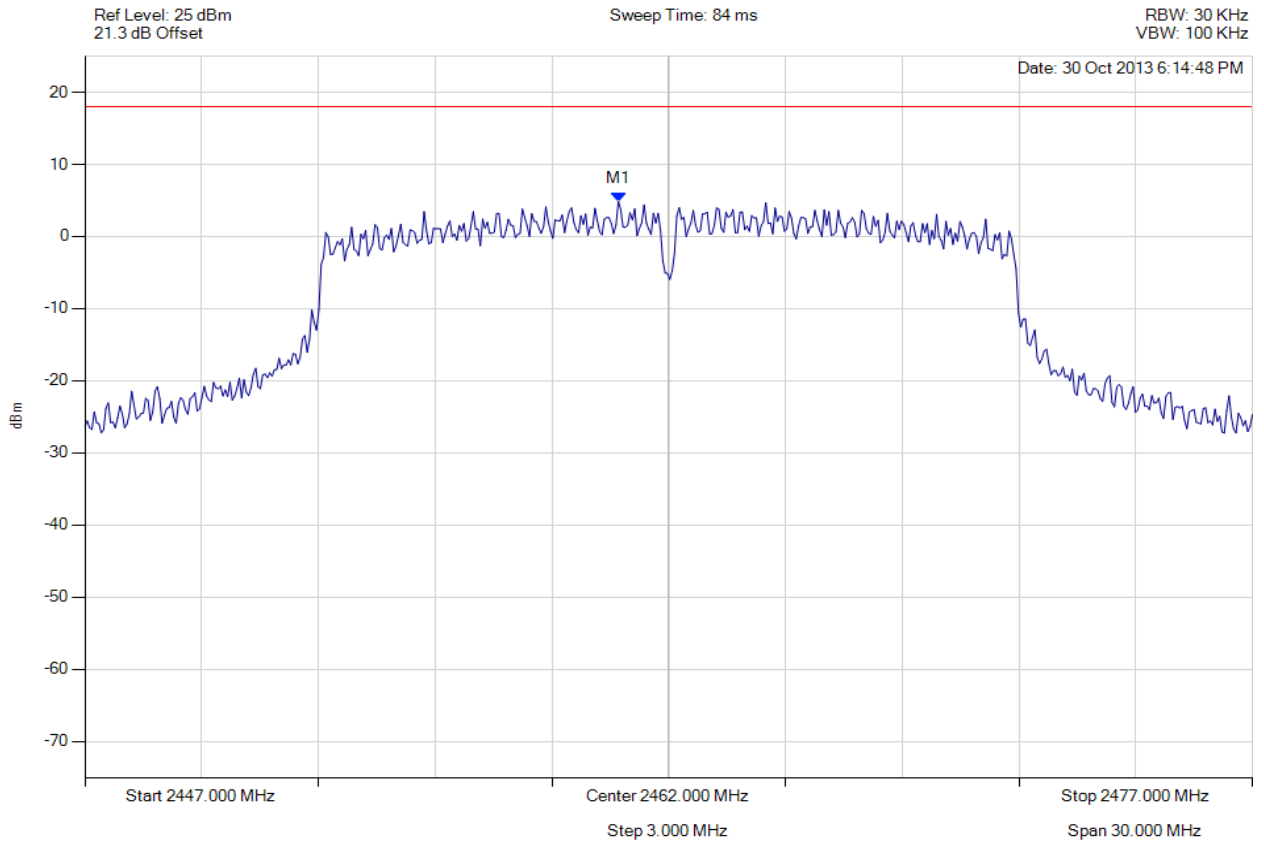

Analyser Setup	Marker : Frequency : Amplitude	Test Results
Detector = MAX PEAK Sweep Count = 0 RF Atten (dB) = 20 Trace Mode = VIEW	M1 : 2460.707 MHz : 4.884 dBm	Limit: ≤ 18.000 dBm Margin: -13.12 dB

[Back to the Matrix](#)

This test report may be reproduced in full only. The document may only be updated by MiCOM Labs personnel. Any changes will be noted in the Document History section of the report.



Title: Spectralink 8741 Basic IP Telephone
To: FCC 47 CFR Part 15.247 & IC RSS-210
Serial #: SPEC27-U4 Rev A
Issue Date: 1st January 2014
Page: 123 of 154



POWER SPECTRAL DENSITY - PEAK

Variant: 802.11a, Channel: 5745.00 MHz, Chain a, Temp: Ambient, Voltage: 3.6 Vdc

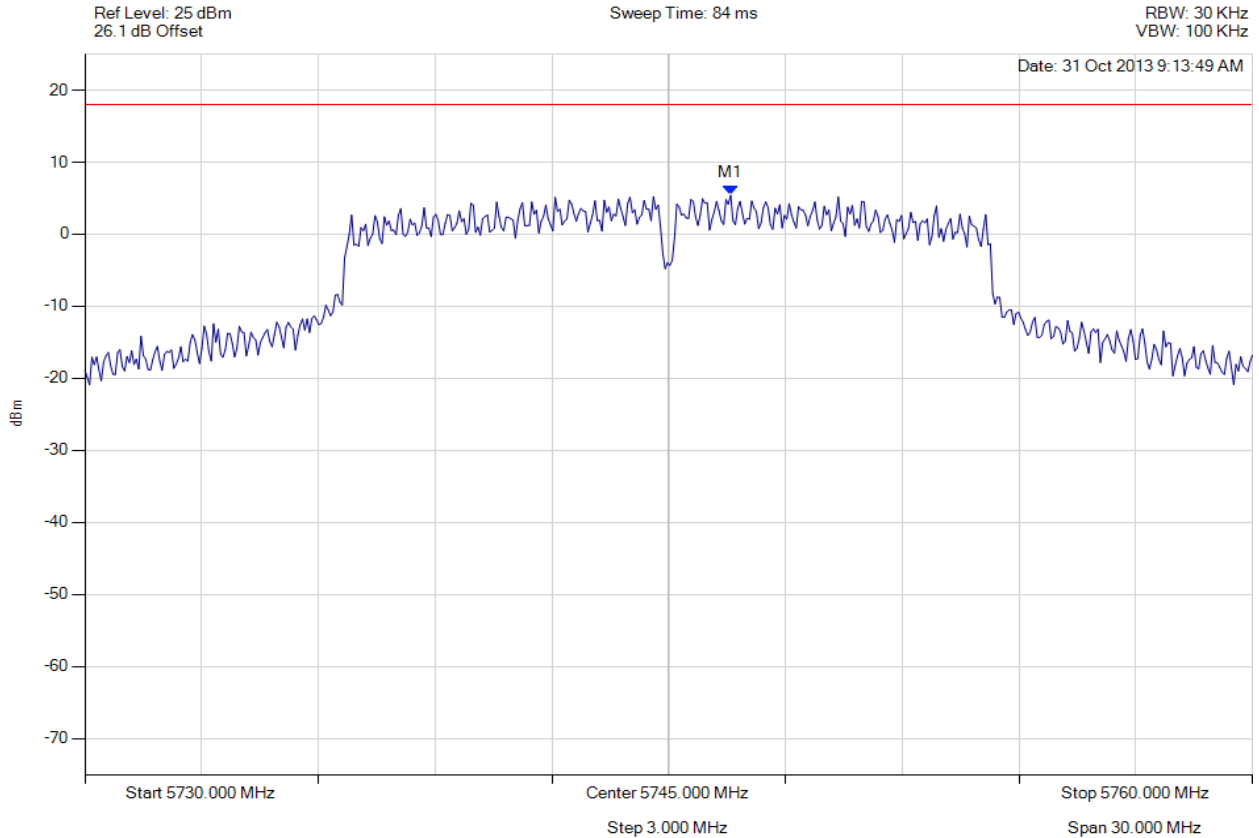

Analyser Setup	Marker : Frequency : Amplitude	Test Results
Detector = MAX PEAK Sweep Count = 0 RF Atten (dB) = 20 Trace Mode = VIEW	M1 : 5746.593 MHz : 5.401 dBm	Limit: ≤ 18.000 dBm Margin: -12.60 dB

[Back to the Matrix](#)

This test report may be reproduced in full only. The document may only be updated by MiCOM Labs personnel. Any changes will be noted in the Document History section of the report.



Title: Spectralink 8741 Basic IP Telephone
To: FCC 47 CFR Part 15.247 & IC RSS-210
Serial #: SPEC27-U4 Rev A
Issue Date: 1st January 2014
Page: 124 of 154



POWER SPECTRAL DENSITY - PEAK

Variant: 802.11a, Channel: 5785.00 MHz, Chain a, Temp: Ambient, Voltage: 3.6 Vdc

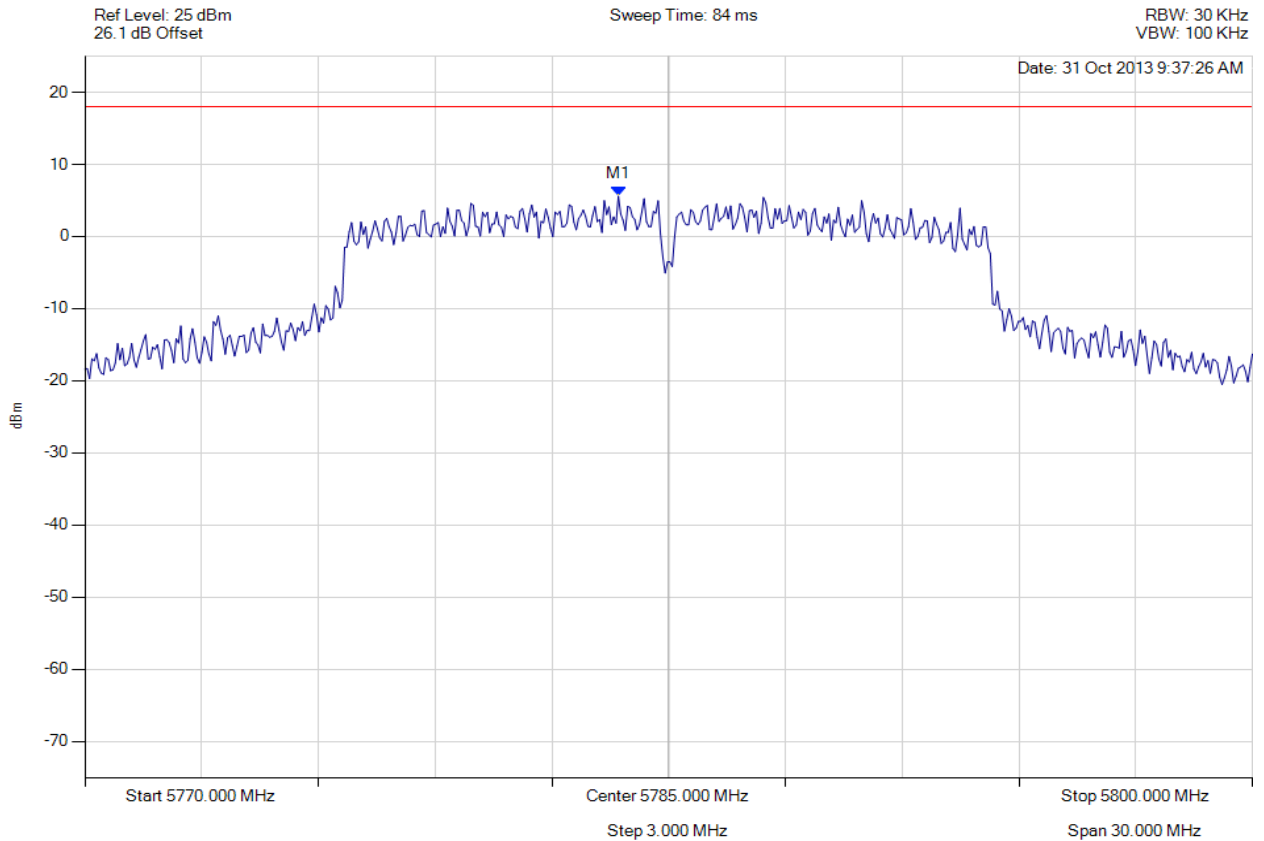

Analyser Setup	Marker : Frequency : Amplitude	Test Results
Detector = MAX PEAK Sweep Count = 0 RF Atten (dB) = 20 Trace Mode = VIEW	M1 : 5783.707 MHz : 5.588 dBm	Limit: ≤ 18.000 dBm Margin: -12.41 dB

[Back to the Matrix](#)

This test report may be reproduced in full only. The document may only be updated by MiCOM Labs personnel. Any changes will be noted in the Document History section of the report.



POWER SPECTRAL DENSITY - PEAK

Variant: 802.11a, Channel: 5825.00 MHz, Chain a, Temp: Ambient, Voltage: 3.6 Vdc

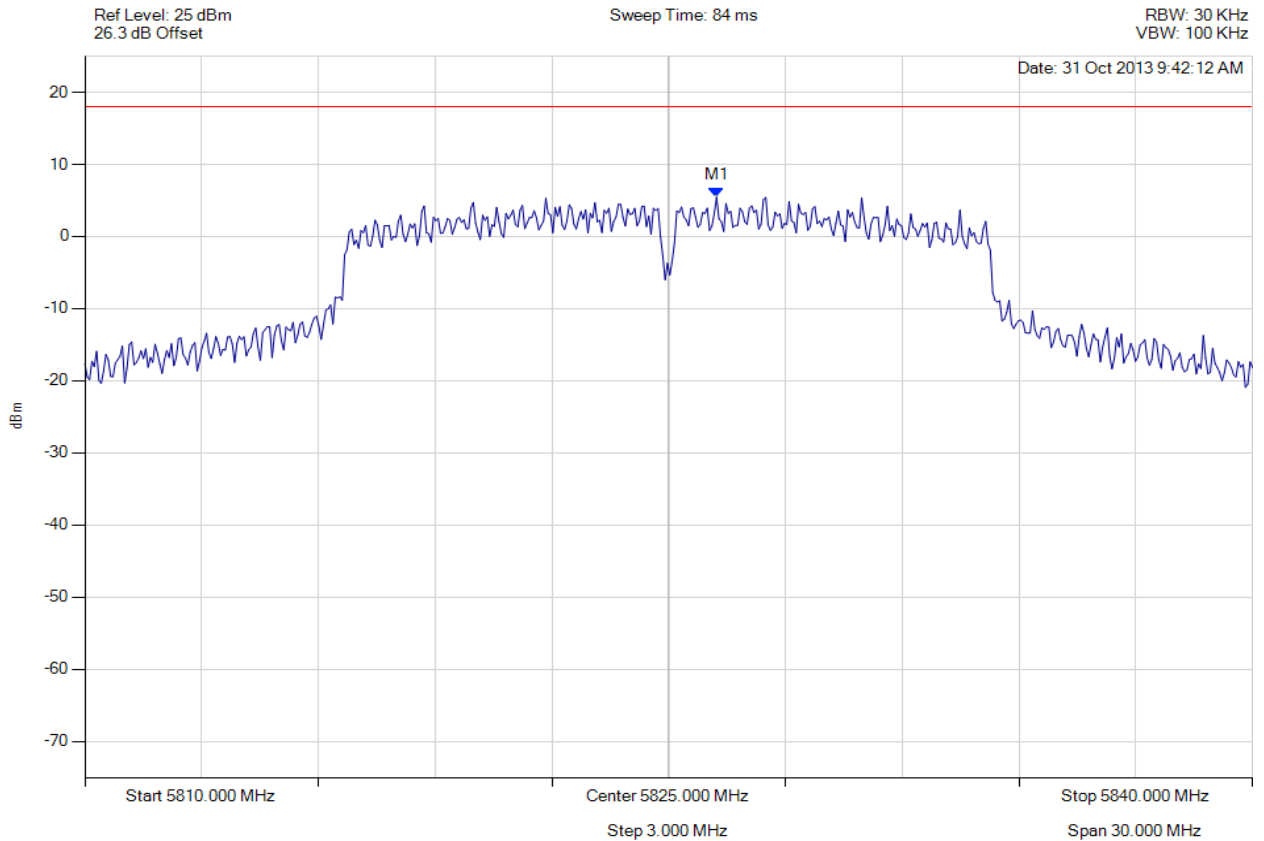

Analyser Setup	Marker : Frequency : Amplitude	Test Results
Detector = MAX PEAK Sweep Count = 0 RF Atten (dB) = 20 Trace Mode = VIEW	M1 : 5826.232 MHz : 5.480 dBm	Limit: ≤ 18.000 dBm Margin: -12.52 dB

[Back to the Matrix](#)

This test report may be reproduced in full only. The document may only be updated by MiCOM Labs personnel. Any changes will be noted in the Document History section of the report.



POWER SPECTRAL DENSITY - PEAK

Variant: 802.11n HT-20, Channel: 5745.00 MHz, Chain a, Temp: Ambient, Voltage: 3.6 Vdc

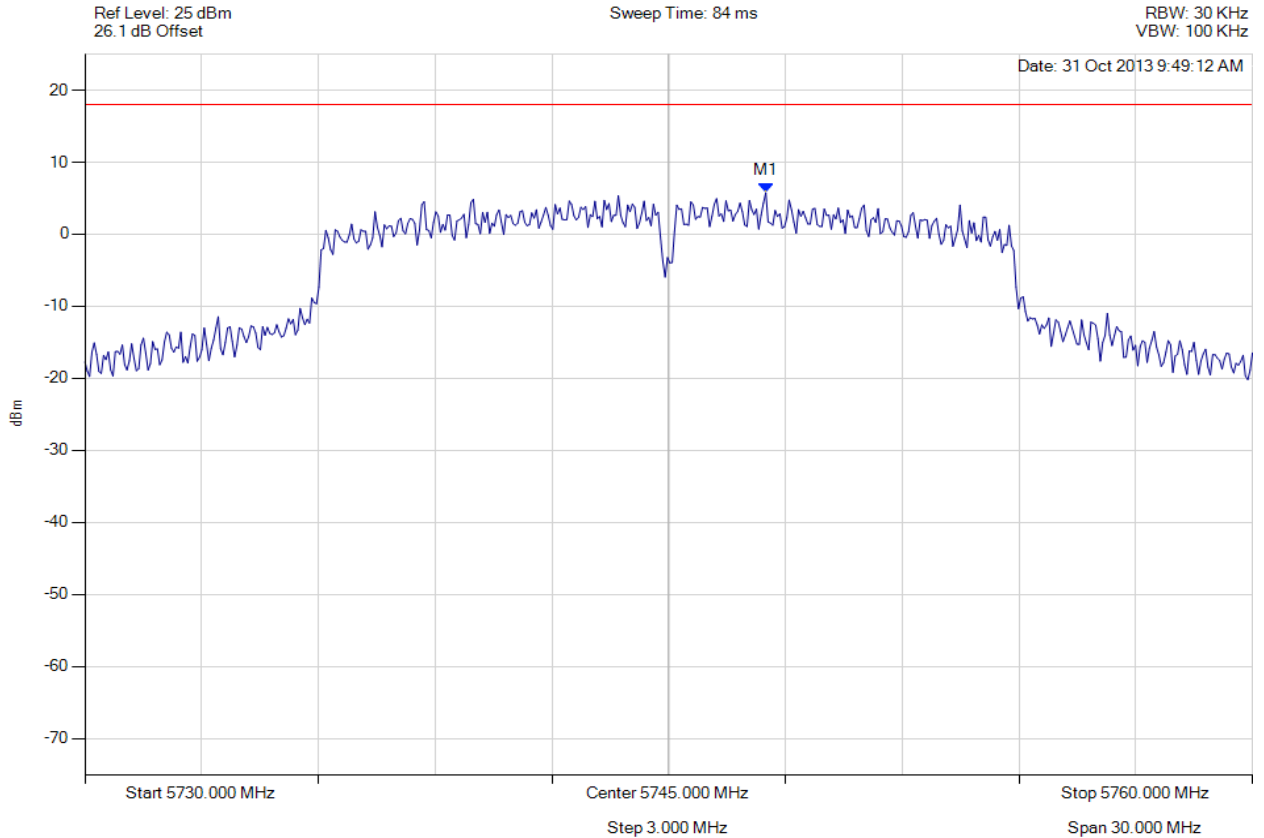

Analyser Setup	Marker : Frequency : Amplitude	Test Results
Detector = MAX PEAK Sweep Count = 0 RF Atten (dB) = 20 Trace Mode = VIEW	M1 : 5747.495 MHz : 5.767 dBm	Limit: ≤ 18.000 dBm Margin: -12.23 dB

[Back to the Matrix](#)

This test report may be reproduced in full only. The document may only be updated by MiCOM Labs personnel. Any changes will be noted in the Document History section of the report.



POWER SPECTRAL DENSITY - PEAK

Variant: 802.11n HT-20, Channel: 5785.00 MHz, Chain a, Temp: Ambient, Voltage: 3.6 Vdc

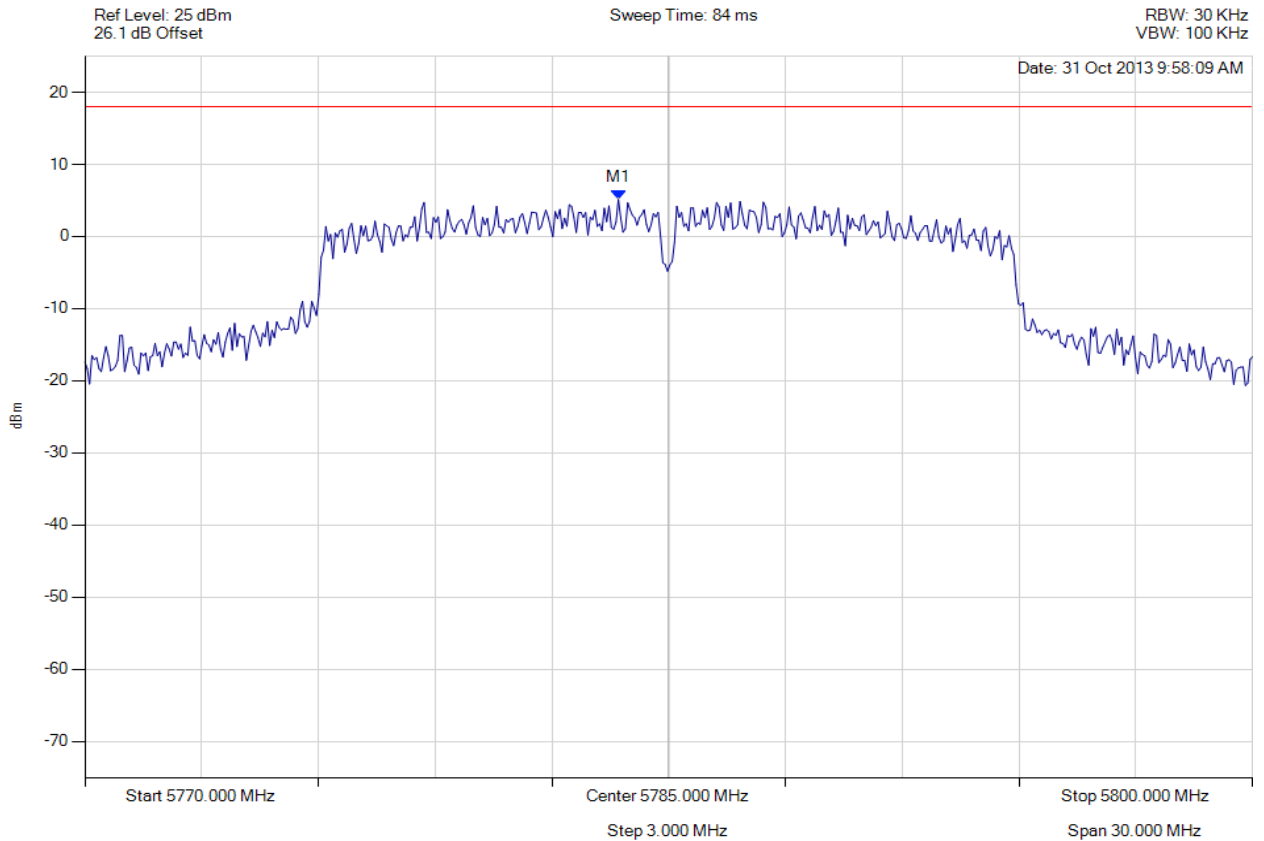

Analyser Setup	Marker : Frequency : Amplitude	Test Results
Detector = MAX PEAK Sweep Count = 0 RF Atten (dB) = 20 Trace Mode = VIEW	M1 : 5783.707 MHz : 5.143 dBm	Limit: ≤ 18.000 dBm Margin: -12.86 dB

[Back to the Matrix](#)

This test report may be reproduced in full only. The document may only be updated by MiCOM Labs personnel. Any changes will be noted in the Document History section of the report.



Title: Spectralink 8741 Basic IP Telephone
To: FCC 47 CFR Part 15.247 & IC RSS-210
Serial #: SPEC27-U4 Rev A
Issue Date: 1st January 2014
Page: 128 of 154



POWER SPECTRAL DENSITY - PEAK

Variant: 802.11n HT-20, Channel: 5825.00 MHz, Chain a, Temp: Ambient, Voltage: 3.6 Vdc

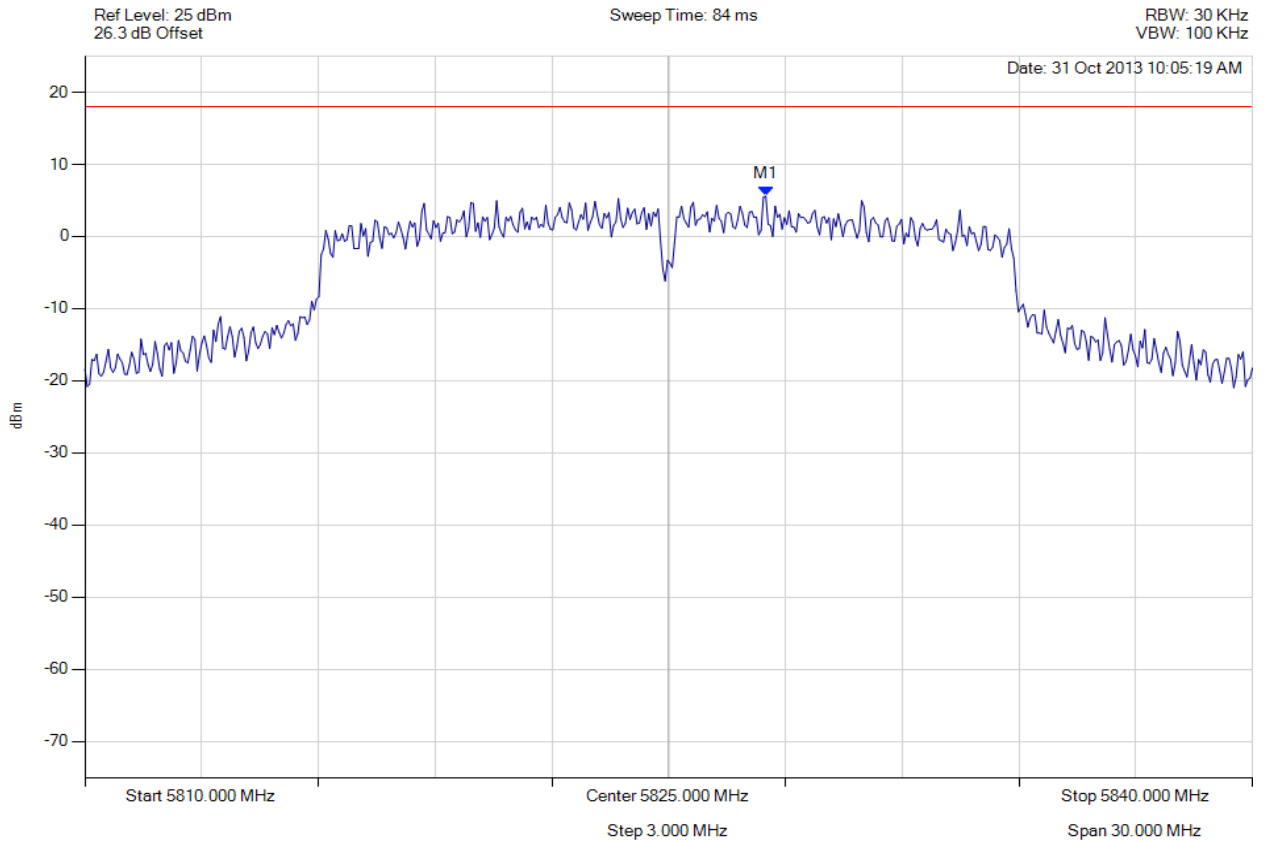

Analyser Setup	Marker : Frequency : Amplitude	Test Results
Detector = MAX PEAK Sweep Count = 0 RF Atten (dB) = 20 Trace Mode = VIEW	M1 : 5827.495 MHz : 5.594 dBm	Limit: ≤ 18.000 dBm Margin: -12.41 dB

[Back to the Matrix](#)

This test report may be reproduced in full only. The document may only be updated by MiCOM Labs personnel. Any changes will be noted in the Document History section of the report.

A.1.4. Conducted Spurious Emissions



CONDUCTED BAND-EDGE EMISSION - PEAK

Variant: 802.11b, Channel: 2412.00 MHz, Chain a, Temp: Ambient, Voltage: 3.6 Vdc

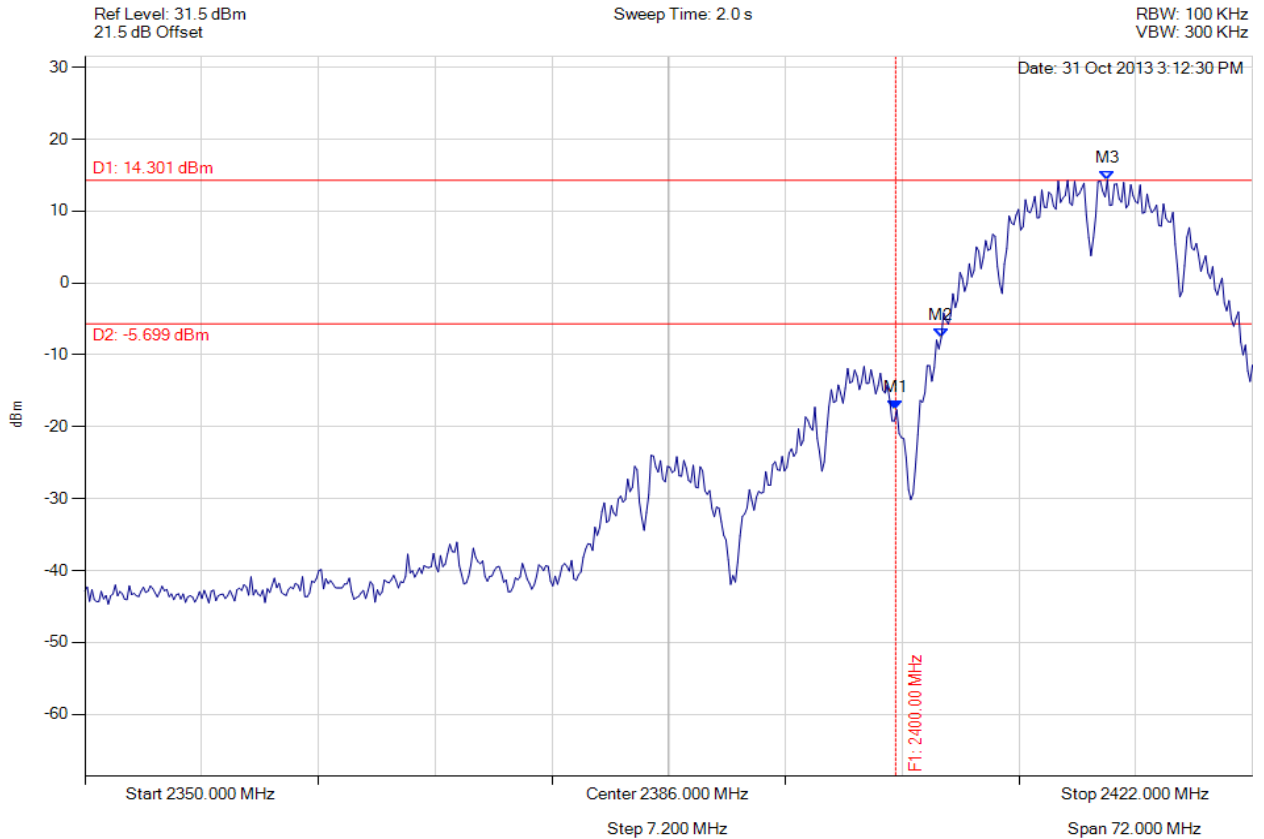

Analyser Setup	Marker : Frequency : Amplitude	Test Results
Detector = MAX PEAK Sweep Count = 0 RF Atten (dB) = 20 Trace Mode = VIEW	M1 : 2400.000 MHz : -17.648 dBm M2 : 2402.810 MHz : -7.607 dBm M3 : 2413.054 MHz : 14.301 dBm	Limit: -5.70 dBm Margin: -11.95 dB

[Back to the Matrix](#)

This test report may be reproduced in full only. The document may only be updated by MiCOM Labs personnel. Any changes will be noted in the Document History section of the report.



CONDUCTED BAND-EDGE EMISSION - PEAK

Variant: 802.11b, Channel: 2462.00 MHz, Chain a, Temp: Ambient, Voltage: 3.6 Vdc

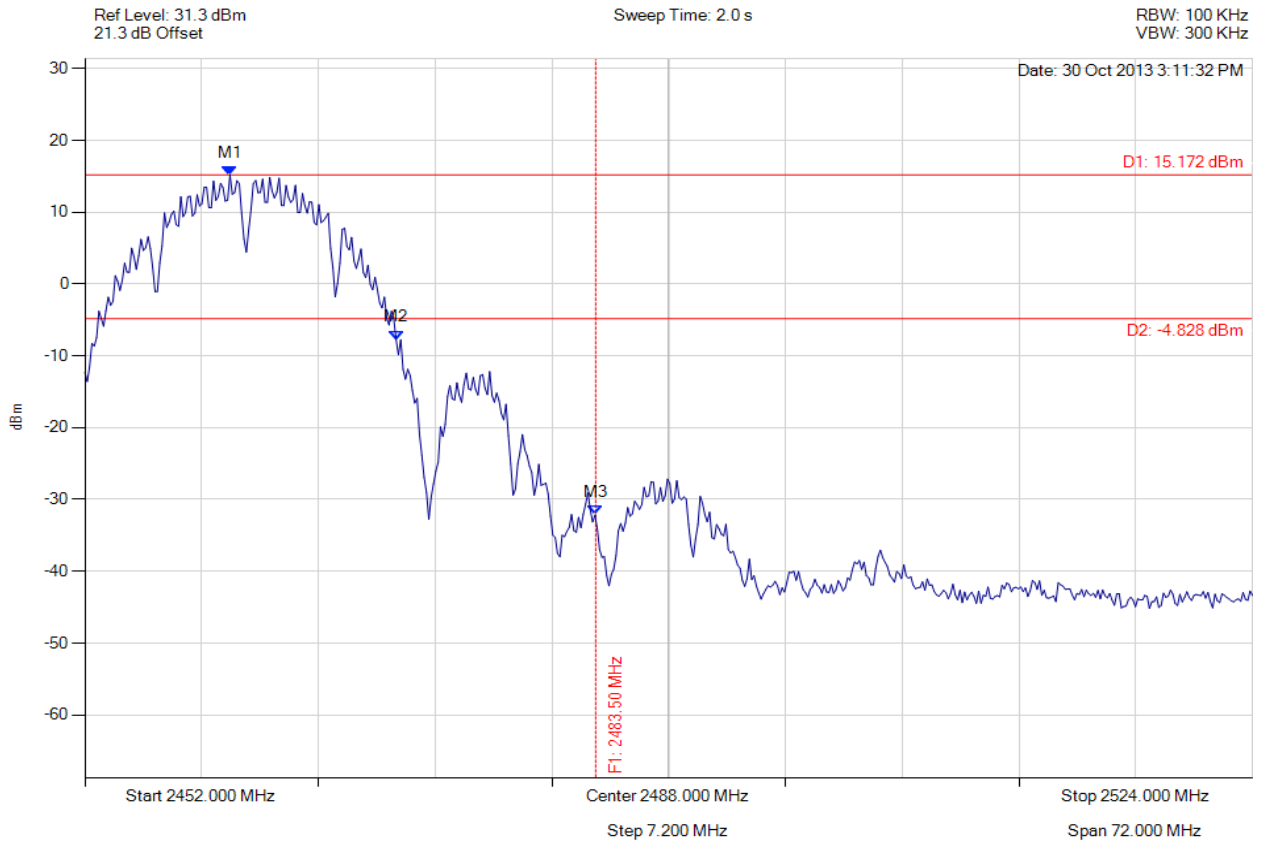

Analyser Setup	Marker : Frequency : Amplitude	Test Results
Detector = MAX PEAK Sweep Count = 0 RF Atten (dB) = 20 Trace Mode = VIEW	M1 : 2460.946 MHz : 15.172 dBm M2 : 2471.190 MHz : -7.740 dBm M3 : 2483.500 MHz : -32.185 dBm	Limit: -4.83 dBm Margin: -27.36 dB

[Back to the Matrix](#)

This test report may be reproduced in full only. The document may only be updated by MiCOM Labs personnel. Any changes will be noted in the Document History section of the report.



CONDUCTED BAND-EDGE EMISSION - PEAK

Variant: 802.11g, Channel: 2412.00 MHz, Chain a, Temp: Ambient, Voltage: 3.6 Vdc

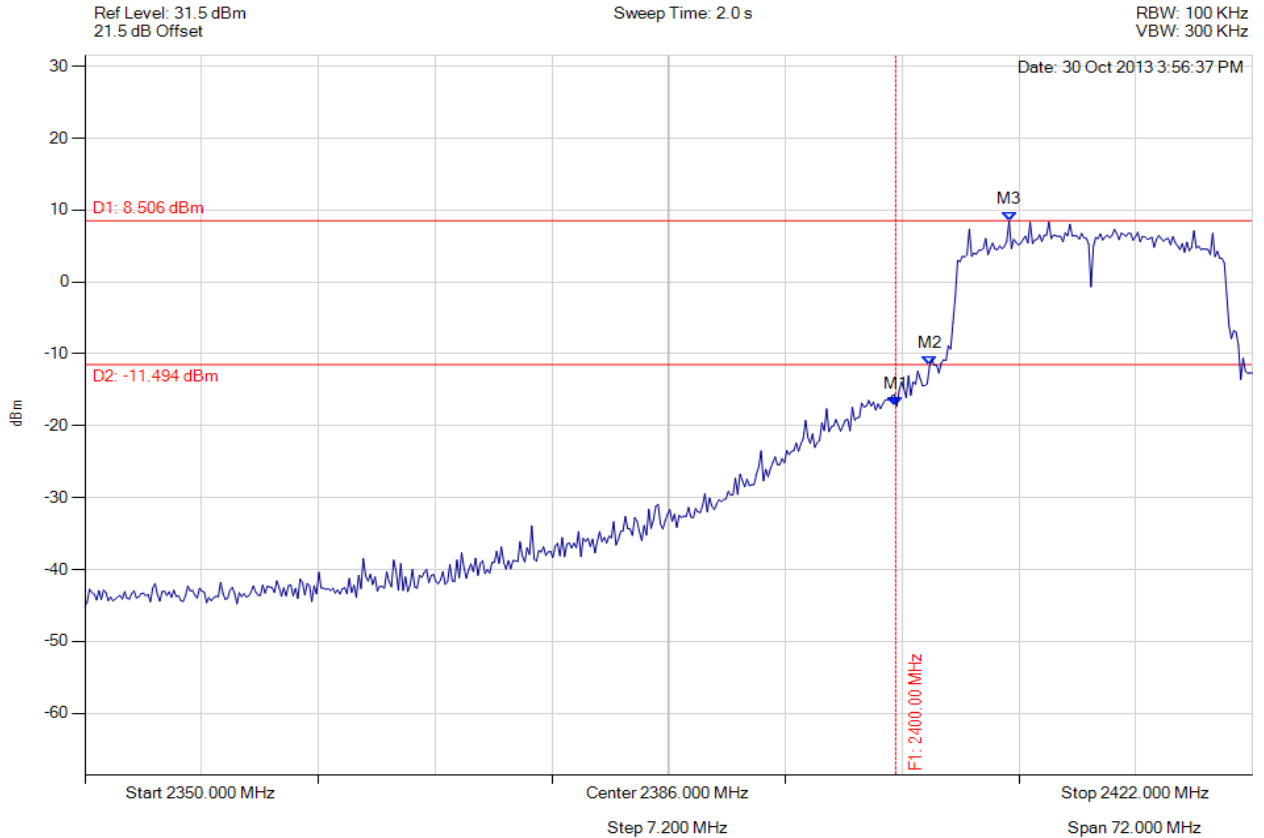

Analyser Setup	Marker : Frequency : Amplitude	Test Results
Detector = MAX PEAK Sweep Count = 0 RF Atten (dB) = 20 Trace Mode = VIEW	M1 : 2400.000 MHz : -17.294 dBm M2 : 2402.088 MHz : -11.678 dBm M3 : 2406.994 MHz : 8.506 dBm	Limit: -11.49 dBm Margin: -5.80 dB

[Back to the Matrix](#)

This test report may be reproduced in full only. The document may only be updated by MiCOM Labs personnel. Any changes will be noted in the Document History section of the report.



CONDUCTED BAND-EDGE EMISSION - PEAK

Variant: 802.11g, Channel: 2462.00 MHz, Chain a, Temp: Ambient, Voltage: 3.6 Vdc

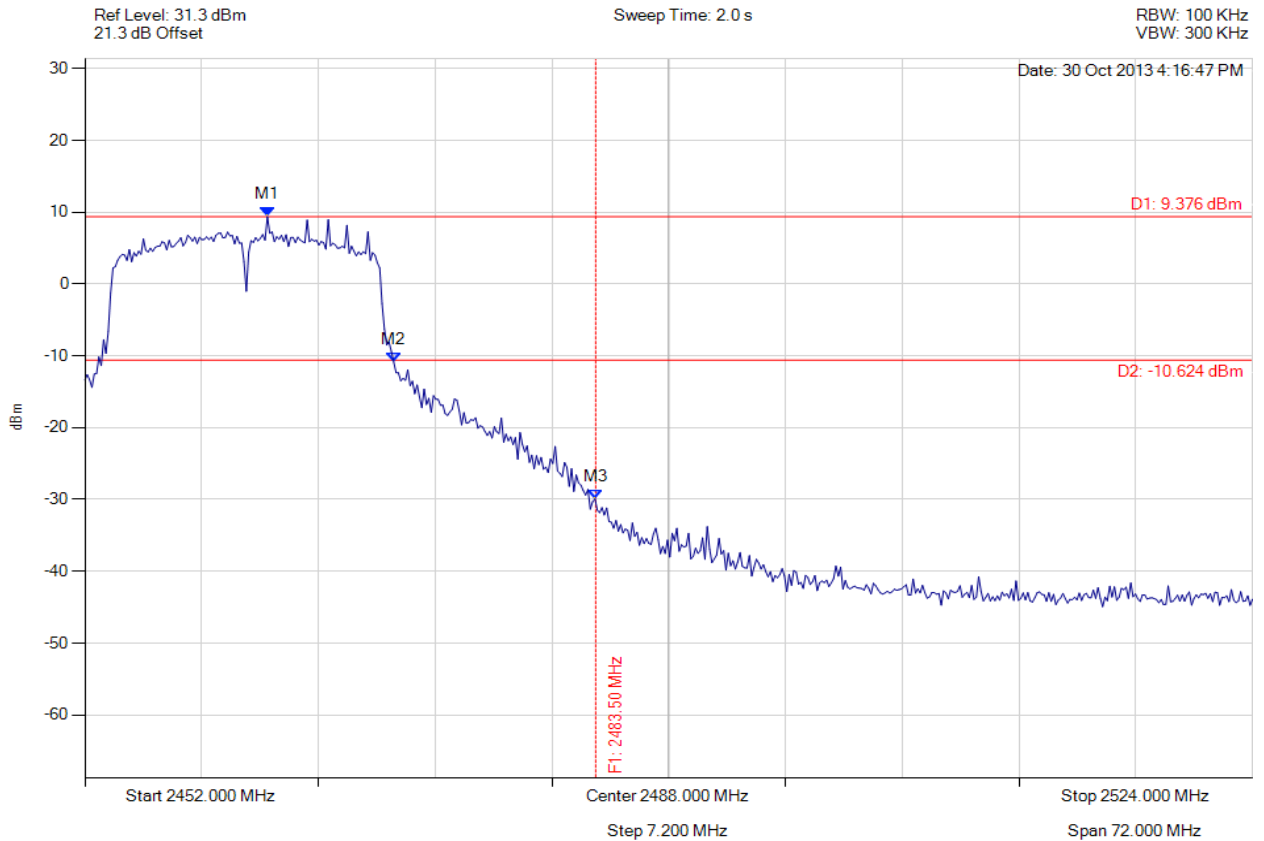

Analyser Setup	Marker : Frequency : Amplitude	Test Results
Detector = MAX PEAK Sweep Count = 0 RF Atten (dB) = 20 Trace Mode = VIEW	M1 : 2463.255 MHz : 9.376 dBm M2 : 2471.046 MHz : -10.874 dBm M3 : 2483.500 MHz : -29.924 dBm	Limit: -10.62 dB Margin: -19.30 dB

[Back to the Matrix](#)

This test report may be reproduced in full only. The document may only be updated by MiCOM Labs personnel. Any changes will be noted in the Document History section of the report.



CONDUCTED BAND-EDGE EMISSION - PEAK

Variant: 802.11n HT-20, Channel: 2412.00 MHz, Chain a, Temp: Ambient, Voltage: 3.6 Vdc

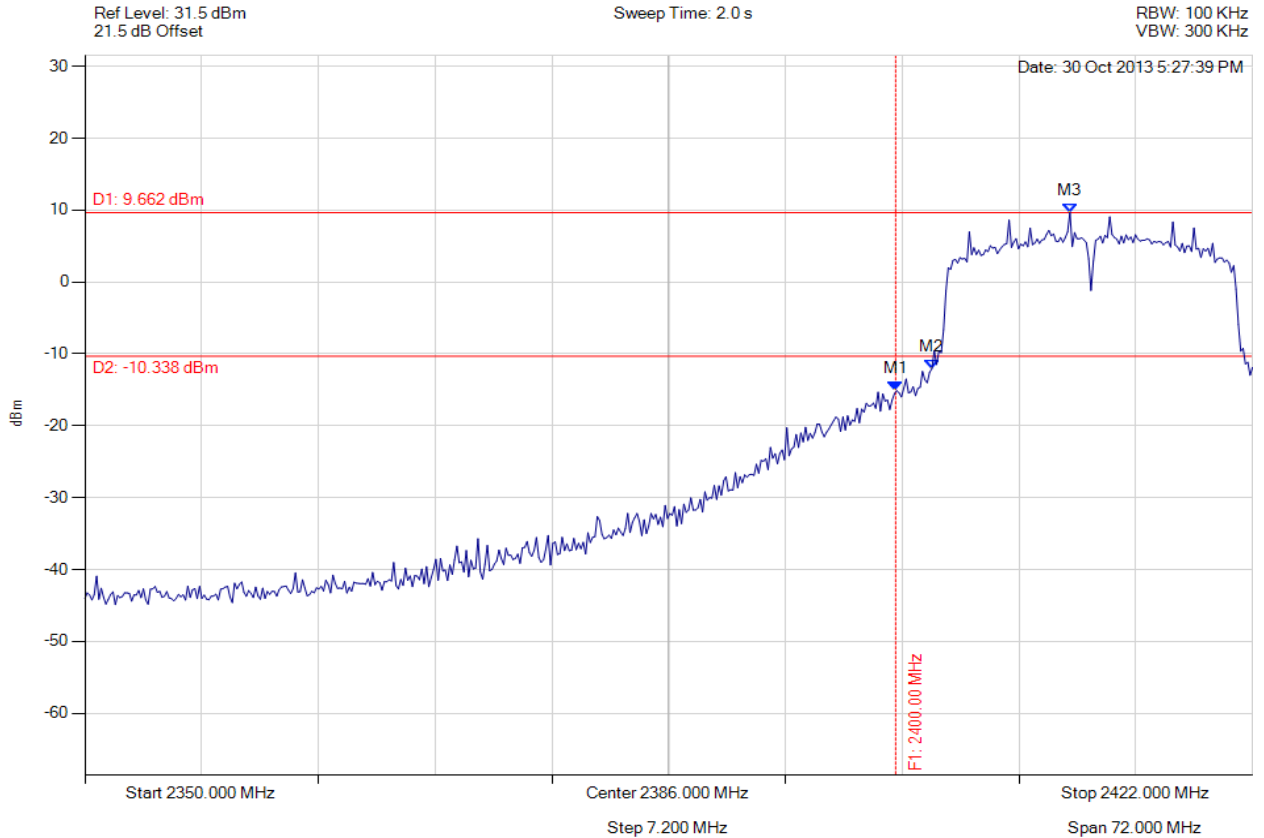

Analyser Setup	Marker : Frequency : Amplitude	Test Results
Detector = MAX PEAK Sweep Count = 0 RF Atten (dB) = 20 Trace Mode = VIEW	M1 : 2400.000 MHz : -15.126 dBm M2 : 2402.232 MHz : -12.045 dBm M3 : 2410.745 MHz : 9.662 dBm	Limit: -10.34 dBm Margin: -4.79 dB

[Back to the Matrix](#)

This test report may be reproduced in full only. The document may only be updated by MiCOM Labs personnel. Any changes will be noted in the Document History section of the report.



CONDUCTED BAND-EDGE EMISSION - PEAK

Variant: 802.11n HT-20, Channel: 2462.00 MHz, Chain a, Temp: Ambient, Voltage: 3.6 Vdc

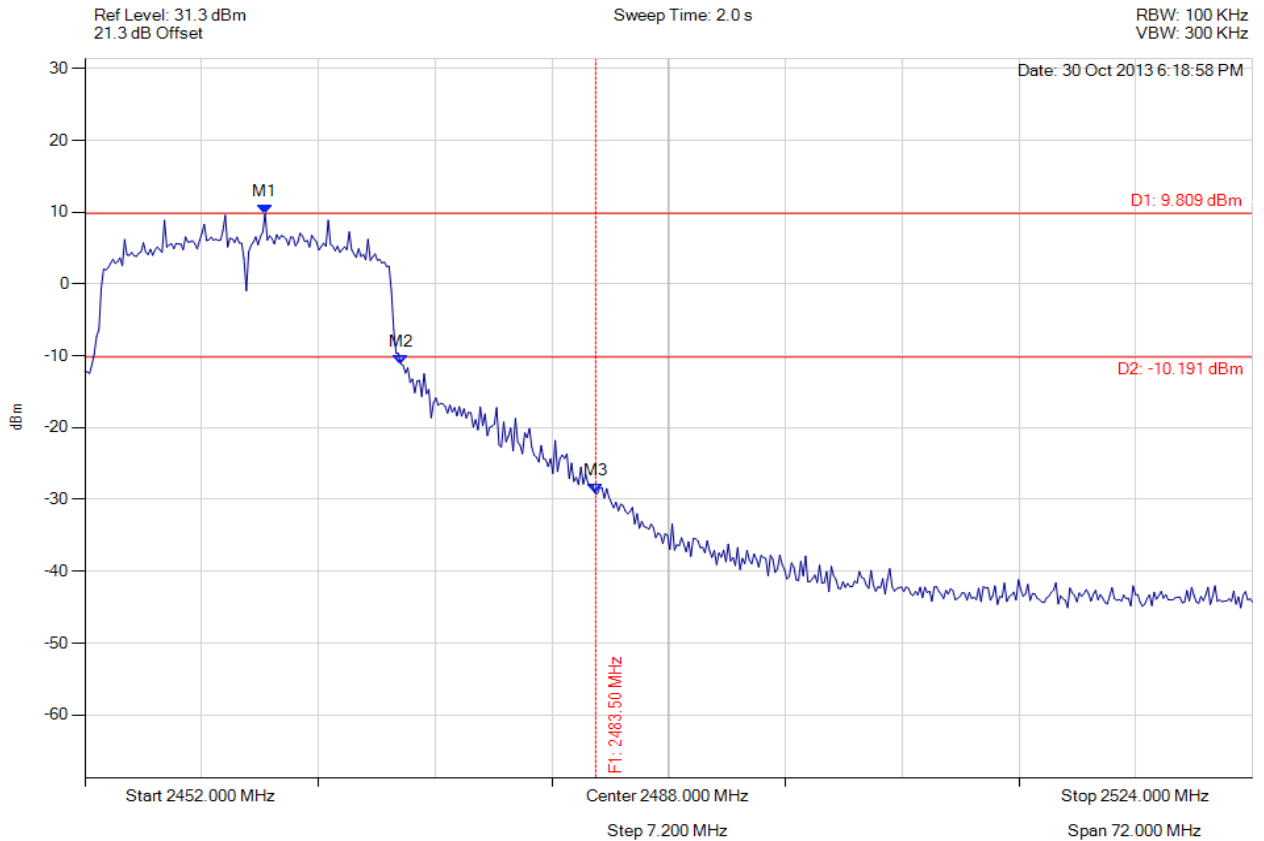

Analyser Setup	Marker : Frequency : Amplitude	Test Results
Detector = MAX PEAK Sweep Count = 0 RF Atten (dB) = 20 Trace Mode = VIEW	M1 : 2463.110 MHz : 9.809 dBm M2 : 2471.479 MHz : -11.148 dBm M3 : 2483.500 MHz : -29.110 dBm	Limit: -10.19 dBm Margin: -18.92 dB

[Back to the Matrix](#)

This test report may be reproduced in full only. The document may only be updated by MiCOM Labs personnel. Any changes will be noted in the Document History section of the report.



CONDUCTED BAND-EDGE EMISSION - PEAK

Variant: 802.11a, Channel: 5745.00 MHz, Chain a, Temp: Ambient, Voltage: 3.6 Vdc

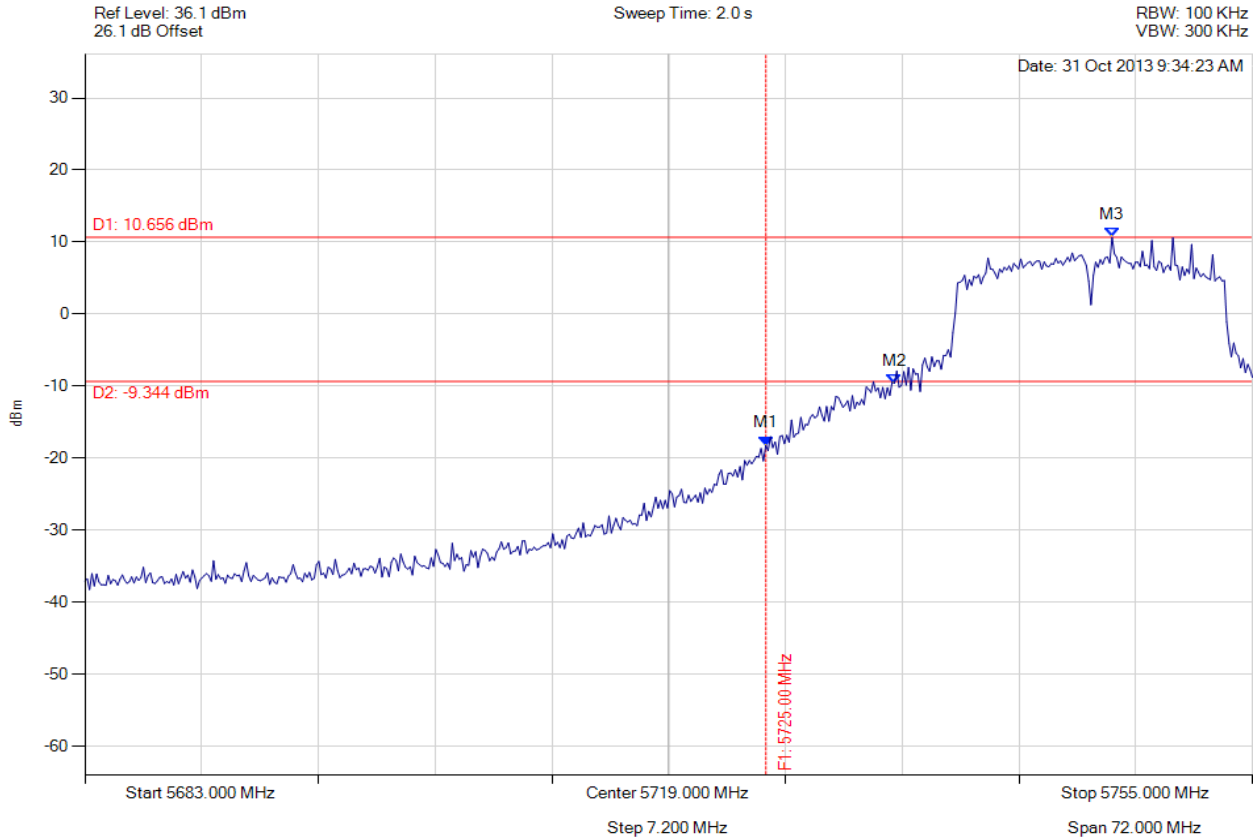

Analyser Setup	Marker : Frequency : Amplitude	Test Results
Detector = MAX PEAK Sweep Count = 0 RF Atten (dB) = 20 Trace Mode = VIEW	M1 : 5725.000 MHz : -18.203 dBm M2 : 5732.924 MHz : -9.584 dBm M3 : 5746.343 MHz : 10.656 dBm	Limit: -9.34 dBm Margin: -8.86 dB

[Back to the Matrix](#)

This test report may be reproduced in full only. The document may only be updated by MiCOM Labs personnel. Any changes will be noted in the Document History section of the report.



Title: Spectralink 8741 Basic IP Telephone
To: FCC 47 CFR Part 15.247 & IC RSS-210
Serial #: SPEC27-U4 Rev A
Issue Date: 1st January 2014
Page: 136 of 154



CONDUCTED BAND-EDGE EMISSION - PEAK

Variant: 802.11a, Channel: 5825.00 MHz, Chain a, Temp: Ambient, Voltage: 3.6 Vdc

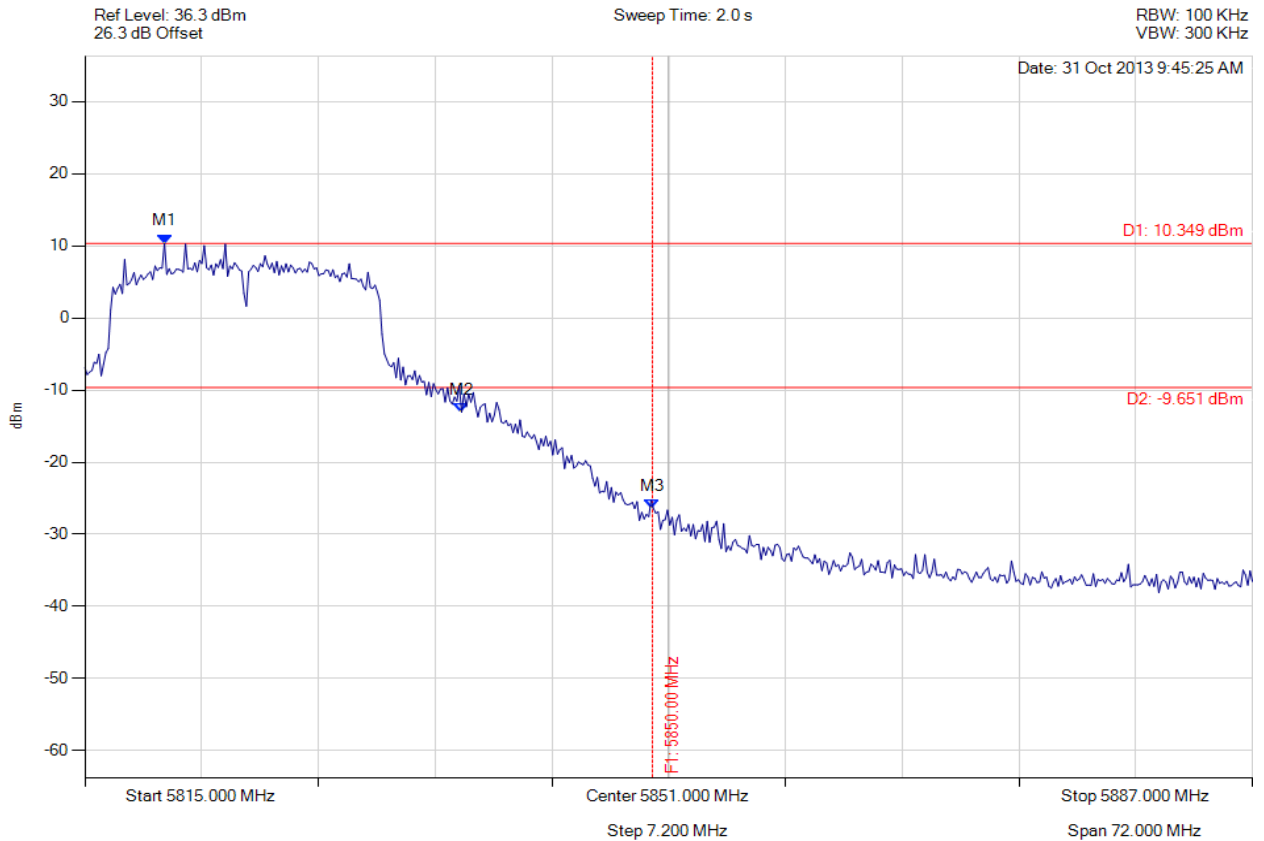

Analyser Setup	Marker : Frequency : Amplitude	Test Results
Detector = MAX PEAK Sweep Count = 0 RF Atten (dB) = 20 Trace Mode = VIEW	M1 : 5819.906 MHz : 10.349 dBm M2 : 5838.230 MHz : -13.061 dBm M3 : 5850.000 MHz : -26.435 dBm	Limit: -9.65 dBm Margin: -16.78 dB

[Back to the Matrix](#)

This test report may be reproduced in full only. The document may only be updated by MiCOM Labs personnel. Any changes will be noted in the Document History section of the report.

CONDUCTED BAND-EDGE EMISSION - PEAK

Variant: 802.11n HT-20, Channel: 5745.00 MHz, Chain a, Temp: Ambient, Voltage: 3.6 Vdc

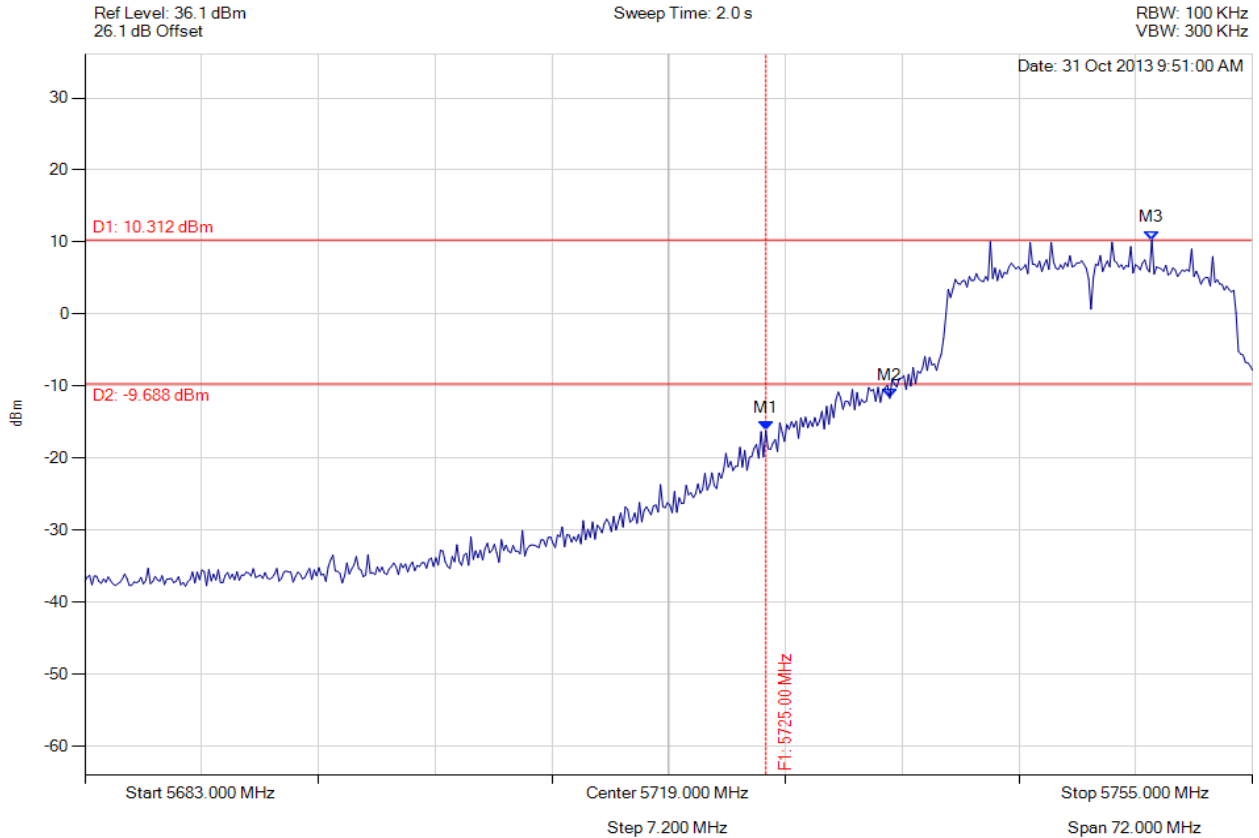

Analyser Setup	Marker : Frequency : Amplitude	Test Results
Detector = MAX PEAK Sweep Count = 0 RF Atten (dB) = 20 Trace Mode = VIEW	M1 : 5725.000 MHz : -16.163 dBm M2 : 5732.635 MHz : -11.675 dBm M3 : 5748.796 MHz : 10.312 dBm	Limit: -9.69 dBm Margin: -6.47 dB

[Back to the Matrix](#)

This test report may be reproduced in full only. The document may only be updated by MiCOM Labs personnel. Any changes will be noted in the Document History section of the report.



CONDUCTED BAND-EDGE EMISSION - PEAK

Variant: 802.11n HT-20, Channel: 5825.00 MHz, Chain a, Temp: Ambient, Voltage: 3.6 Vdc

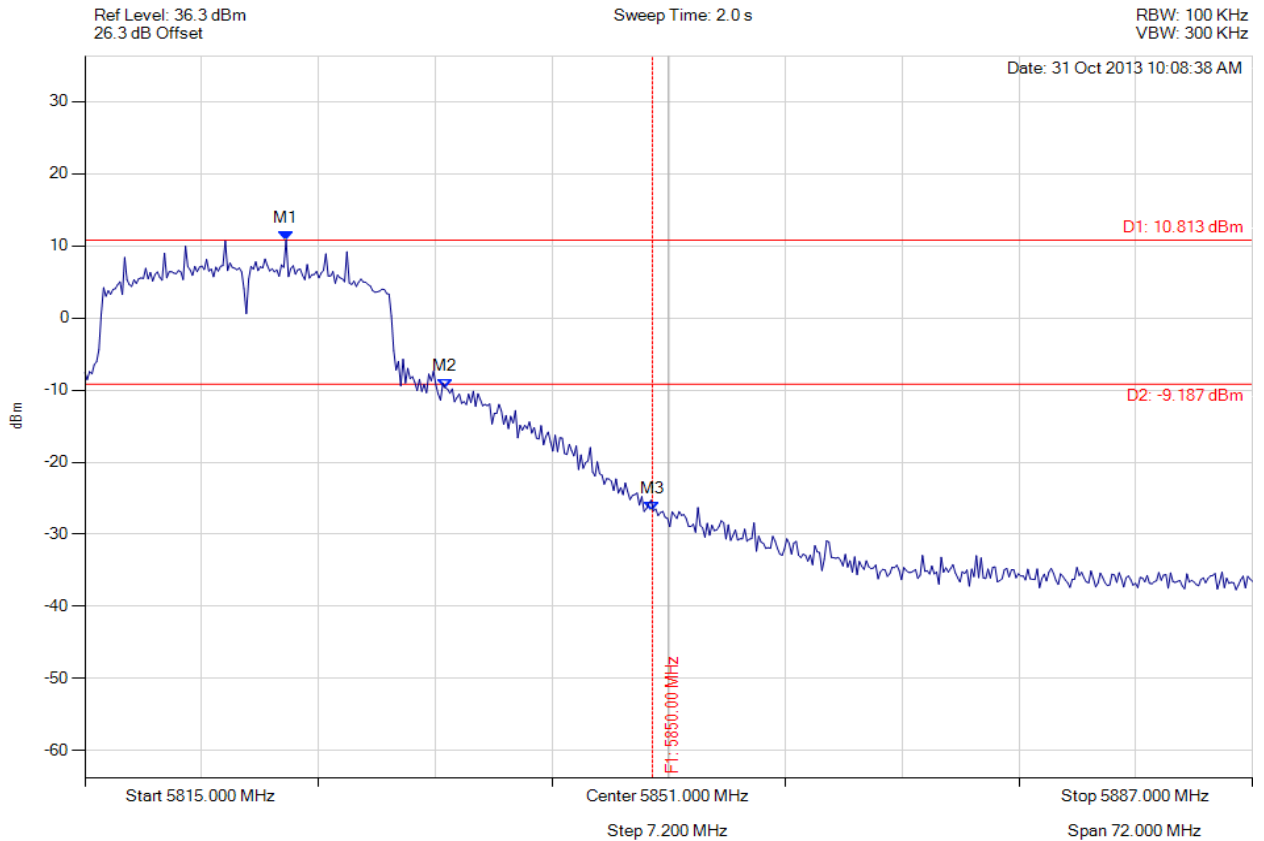

Analyser Setup	Marker : Frequency : Amplitude	Test Results
Detector = MAX PEAK Sweep Count = 0 RF Atten (dB) = 20 Trace Mode = VIEW	M1 : 5827.409 MHz : 10.813 dBm M2 : 5837.220 MHz : -9.683 dBm M3 : 5850.000 MHz : -26.764 dBm	Limit: -9.19 dBm Margin: -17.57 dB

[Back to the Matrix](#)

This test report may be reproduced in full only. The document may only be updated by MiCOM Labs personnel. Any changes will be noted in the Document History section of the report.



CONDUCTED SPURIOUS EMISSIONS - PEAK

Variant: 802.11b, Channel: 2412.00 MHz, Chain a, Temp: Ambient, Voltage: 3.6 Vdc

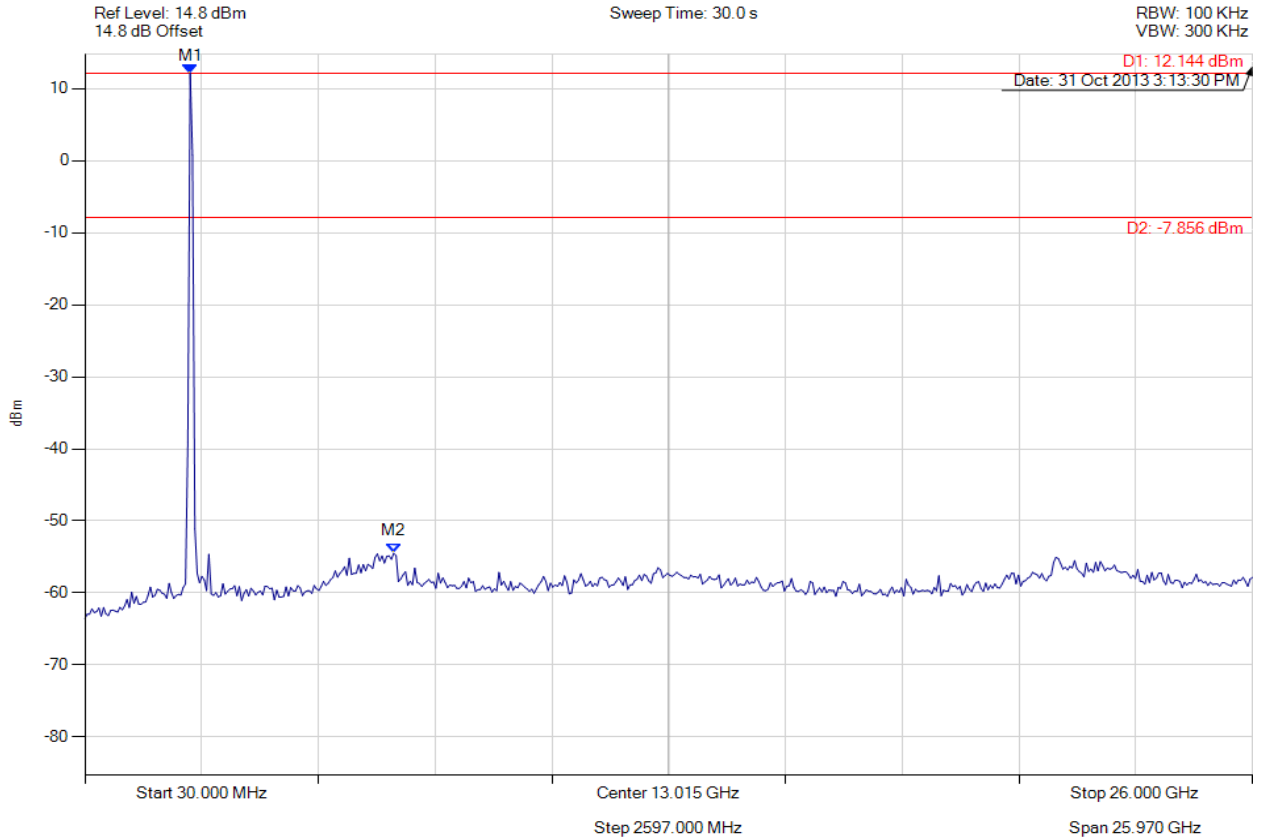

Analyser Setup	Marker : Frequency : Amplitude	Test Results
Detector = MAX PEAK Sweep Count = 0 RF Atten (dB) = 10 Trace Mode = VIEW	M1 : 2371.984 MHz : 12.144 dBm M2 : 6899.820 MHz : -54.490 dBm	Limit: -7.86 dBm Margin: -46.63 dB

[Back to the Matrix](#)

This test report may be reproduced in full only. The document may only be updated by MiCOM Labs personnel. Any changes will be noted in the Document History section of the report.



CONDUCTED SPURIOUS EMISSIONS - PEAK

Variant: 802.11b, Channel: 2437.00 MHz, Chain a, Temp: Ambient, Voltage: 3.6 Vdc

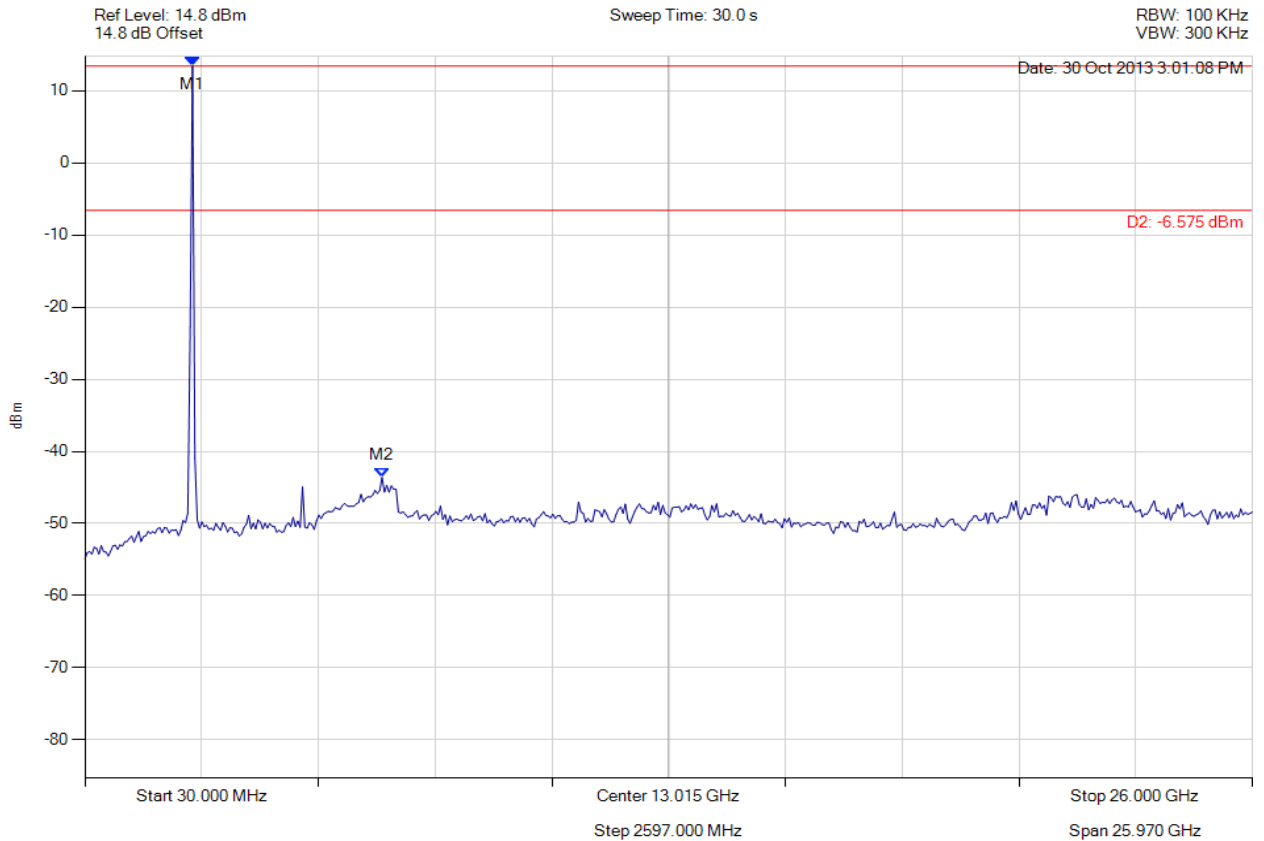

Analyser Setup	Marker : Frequency : Amplitude	Test Results
Detector = MAX PEAK Sweep Count = 0 RF Atten (dB) = 20 Trace Mode = VIEW	M1 : 2424.028 MHz : 13.425 dBm M2 : 6639.599 MHz : -43.609 dBm	Limit: -6.58 dBm Margin: -37.03 dB

[Back to the Matrix](#)

This test report may be reproduced in full only. The document may only be updated by MiCOM Labs personnel. Any changes will be noted in the Document History section of the report.



CONDUCTED SPURIOUS EMISSIONS - PEAK

Variant: 802.11b, Channel: 2462.00 MHz, Chain a, Temp: Ambient, Voltage: 3.6 Vdc

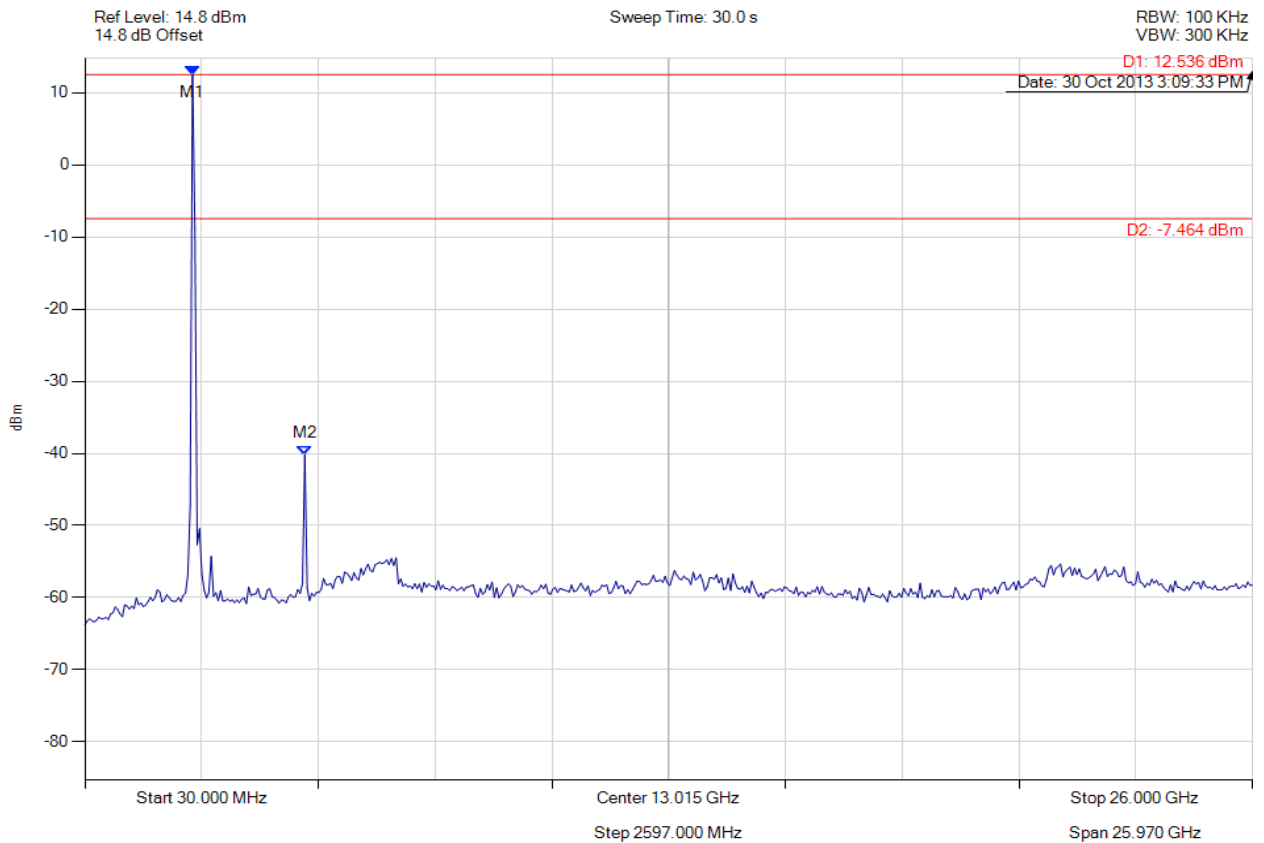

Analyser Setup	Marker : Frequency : Amplitude	Test Results
Detector = MAX PEAK Sweep Count = 0 RF Atten (dB) = 10 Trace Mode = VIEW	M1 : 2424.028 MHz : 12.536 dBm M2 : 4922.144 MHz : -40.203 dBm	Limit: -7.46 dBm Margin: -32.74 dB

[Back to the Matrix](#)

This test report may be reproduced in full only. The document may only be updated by MiCOM Labs personnel. Any changes will be noted in the Document History section of the report.



CONDUCTED SPURIOUS EMISSIONS - PEAK

Variant: 802.11g, Channel: 2412.00 MHz, Chain a, Temp: Ambient, Voltage: 3.6 Vdc

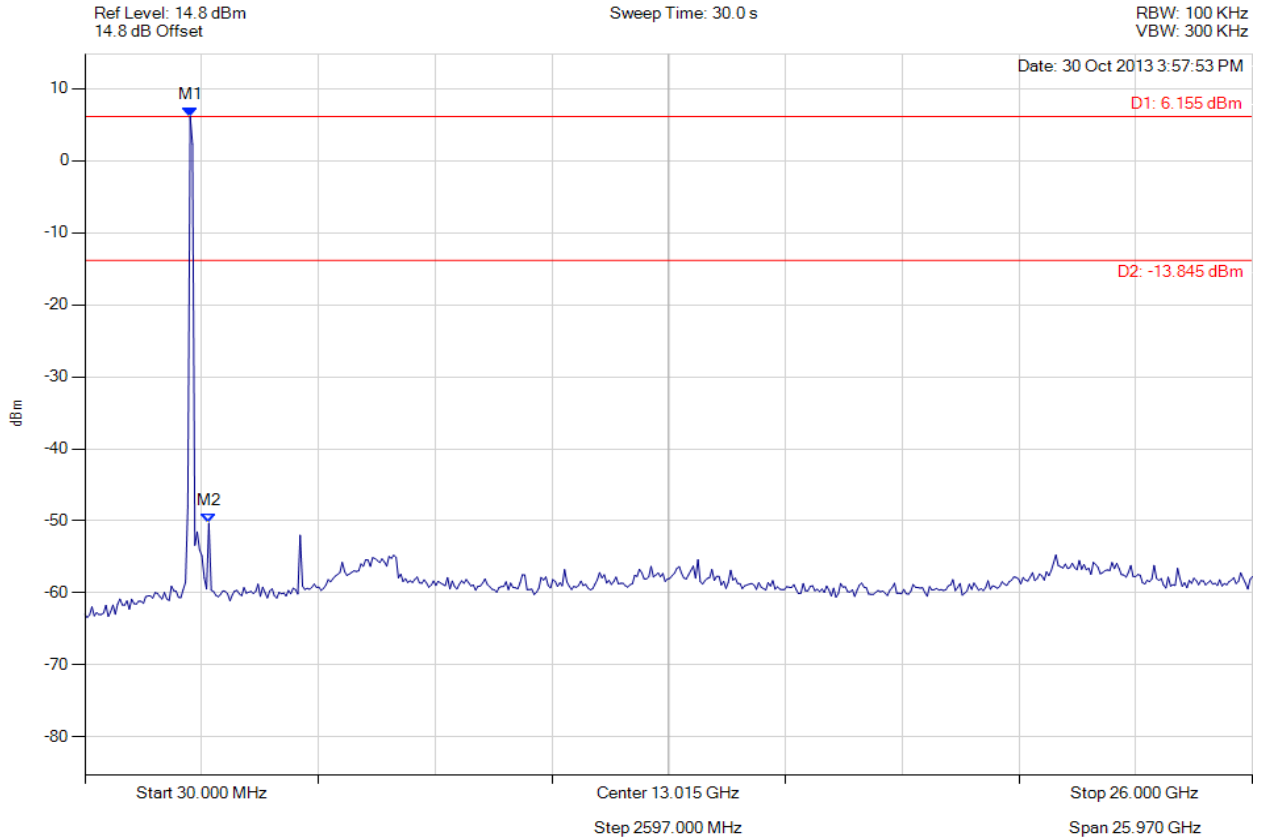

Analyser Setup	Marker : Frequency : Amplitude	Test Results
Detector = MAX PEAK Sweep Count = 0 RF Atten (dB) = 10 Trace Mode = VIEW	M1 : 2371.984 MHz : 6.155 dBm M2 : 2788.337 MHz : -50.312 dBm	Limit: -13.85 dBm Margin: -36.46 dB

[Back to the Matrix](#)

This test report may be reproduced in full only. The document may only be updated by MiCOM Labs personnel. Any changes will be noted in the Document History section of the report.



CONDUCTED SPURIOUS EMISSIONS - PEAK

Variant: 802.11g, Channel: 2437.00 MHz, Chain a, Temp: Ambient, Voltage: 3.6 Vdc

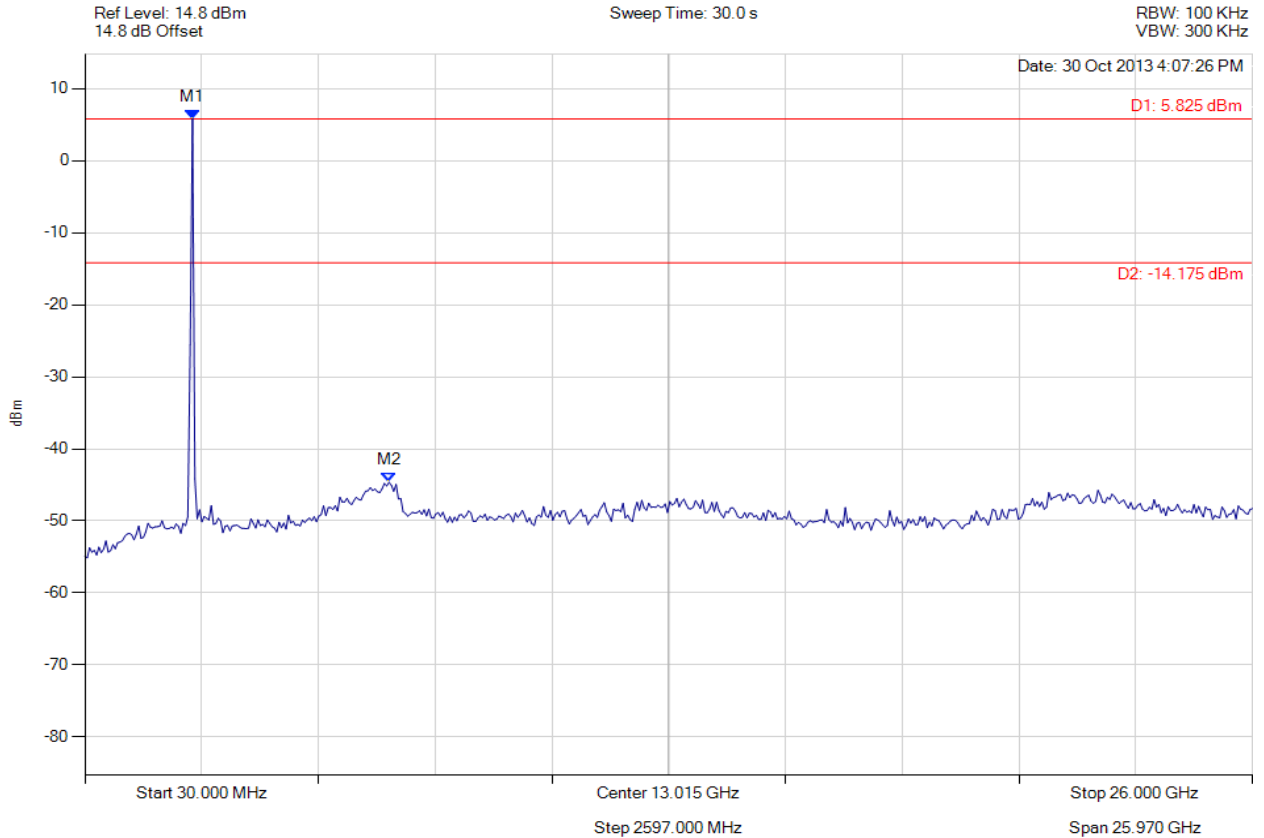

Analyser Setup	Marker : Frequency : Amplitude	Test Results
Detector = MAX PEAK Sweep Count = 0 RF Atten (dB) = 20 Trace Mode = VIEW	M1 : 2424.028 MHz : 5.825 dBm M2 : 6795.731 MHz : -44.636 dBm	Limit: -14.18 dBm Margin: -30.46 dB

[Back to the Matrix](#)

This test report may be reproduced in full only. The document may only be updated by MiCOM Labs personnel. Any changes will be noted in the Document History section of the report.



CONDUCTED SPURIOUS EMISSIONS - PEAK

Variant: 802.11g, Channel: 2462.00 MHz, Chain a, Temp: Ambient, Voltage: 3.6 Vdc

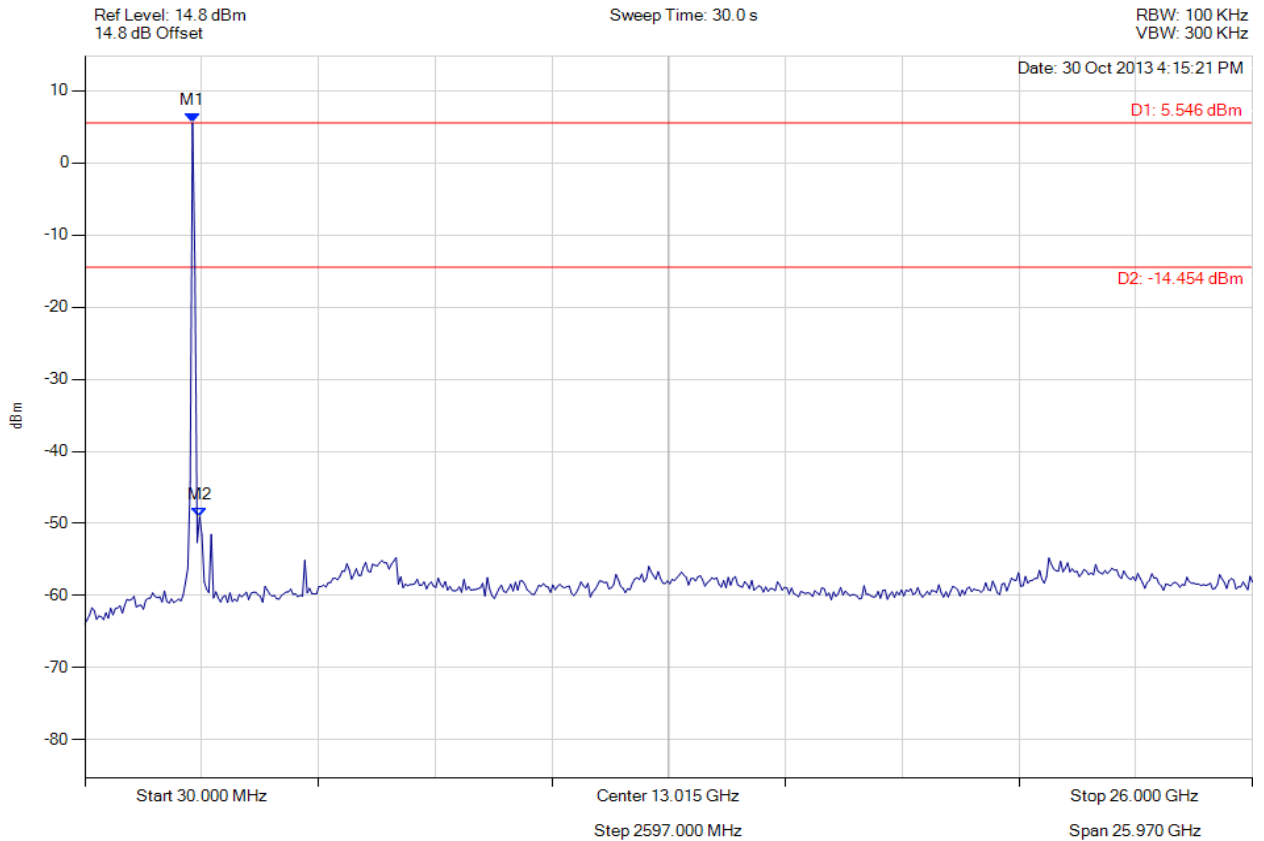

Analyser Setup	Marker : Frequency : Amplitude	Test Results
Detector = MAX PEAK Sweep Count = 0 RF Atten (dB) = 10 Trace Mode = VIEW	M1 : 2424.028 MHz : 5.546 dBm M2 : 2580.160 MHz : -49.070 dBm	Limit: -14.45 dBm Margin: -34.62 dB

[Back to the Matrix](#)

This test report may be reproduced in full only. The document may only be updated by MiCOM Labs personnel. Any changes will be noted in the Document History section of the report.



CONDUCTED SPURIOUS EMISSIONS - PEAK

Variant: 802.11n HT-20, Channel: 2412.00 MHz, Chain a, Temp: Ambient, Voltage: 3.6 Vdc

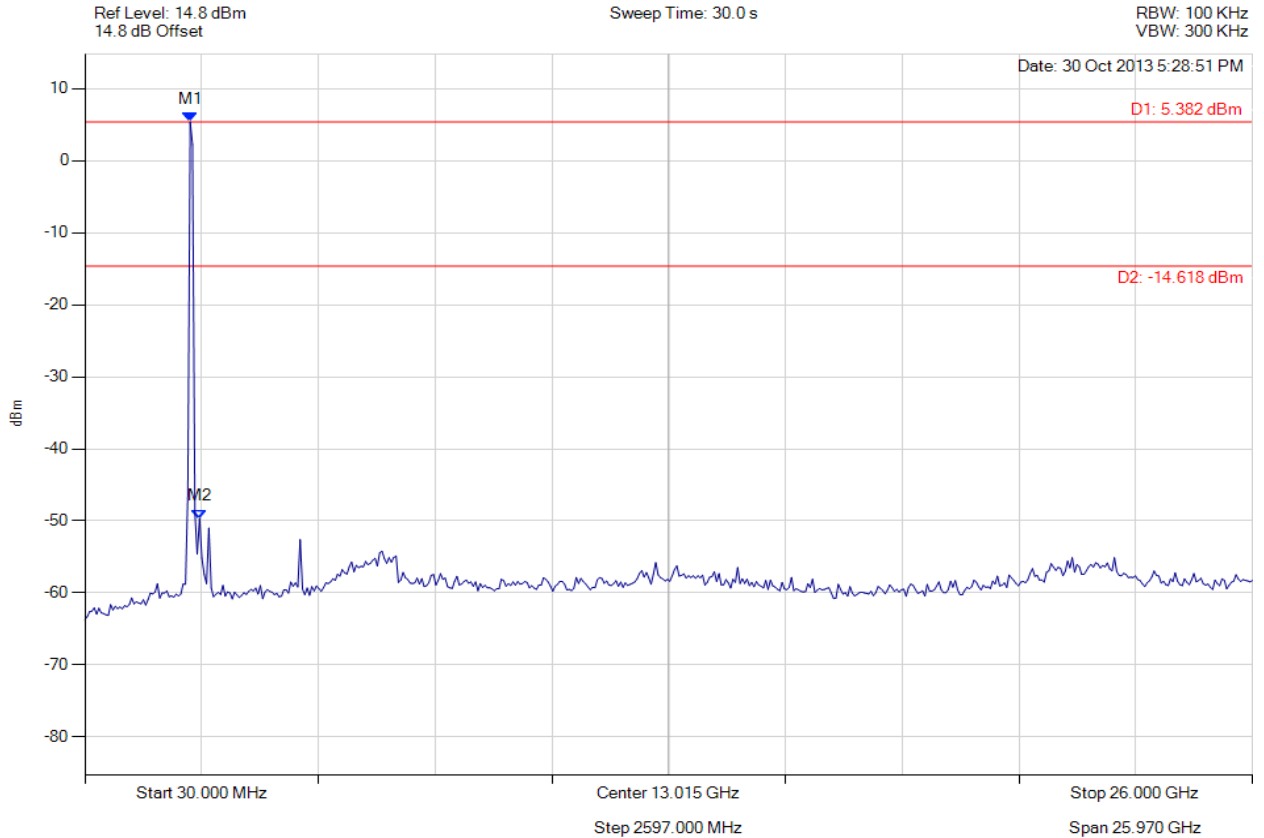

Analyser Setup	Marker : Frequency : Amplitude	Test Results
Detector = MAX PEAK Sweep Count = 0 RF Atten (dB) = 10 Trace Mode = VIEW	M1 : 2371.984 MHz : 5.382 dBm M2 : 2580.160 MHz : -49.682 dBm	Limit: -14.62 dBm Margin: -35.06 dB

[Back to the Matrix](#)

This test report may be reproduced in full only. The document may only be updated by MiCOM Labs personnel. Any changes will be noted in the Document History section of the report.



CONDUCTED SPURIOUS EMISSIONS - PEAK

Variant: 802.11n HT-20, Channel: 2437.00 MHz, Chain a, Temp: Ambient, Voltage: 3.6 Vdc

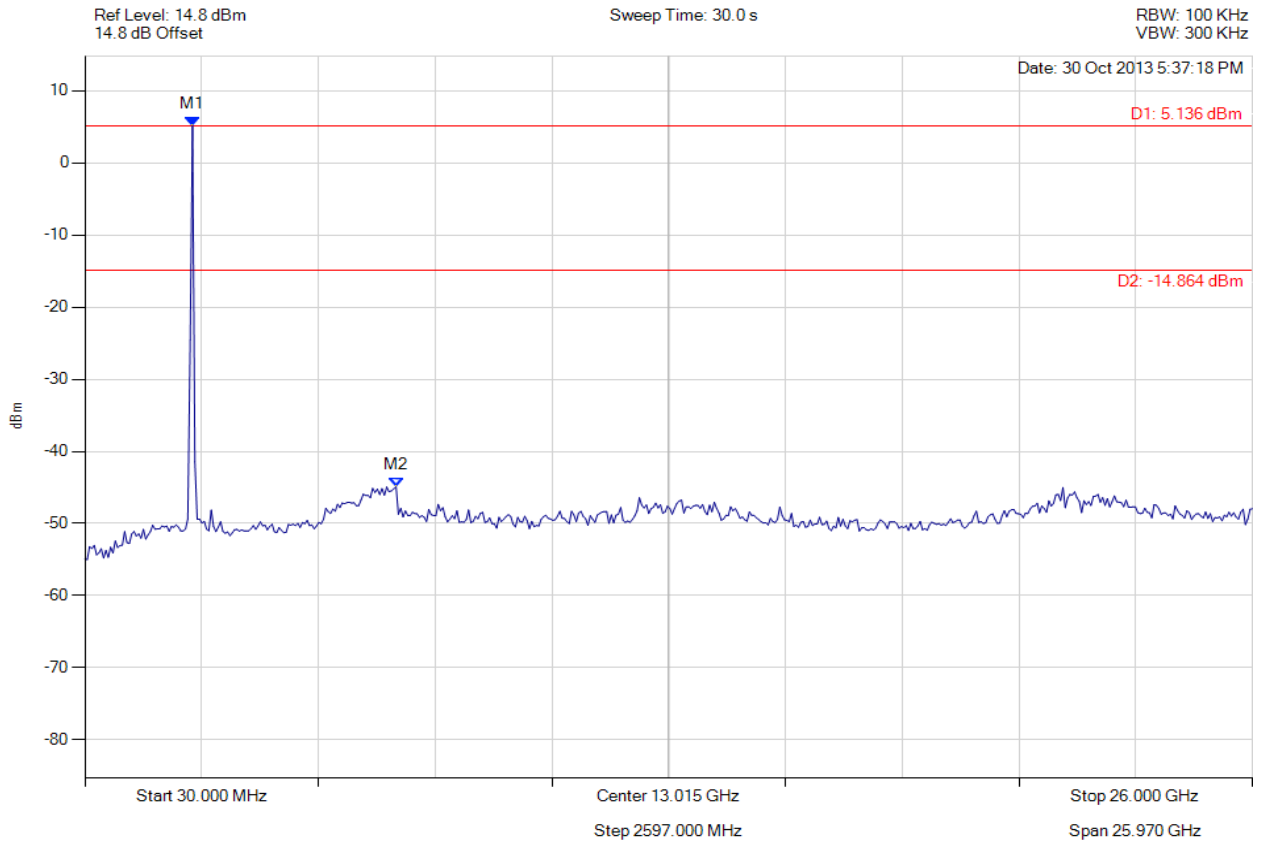

Analyser Setup	Marker : Frequency : Amplitude	Test Results
Detector = MAX PEAK Sweep Count = 0 RF Atten (dB) = 20 Trace Mode = VIEW	M1 : 2424.028 MHz : 5.136 dBm M2 : 6951.864 MHz : -44.921 dBm	Limit: -14.86 dBm Margin: -30.06 dB

[Back to the Matrix](#)

This test report may be reproduced in full only. The document may only be updated by MiCOM Labs personnel. Any changes will be noted in the Document History section of the report.



CONDUCTED SPURIOUS EMISSIONS - PEAK

Variant: 802.11n HT-20, Channel: 2462.00 MHz, Chain a, Temp: Ambient, Voltage: 3.6 Vdc

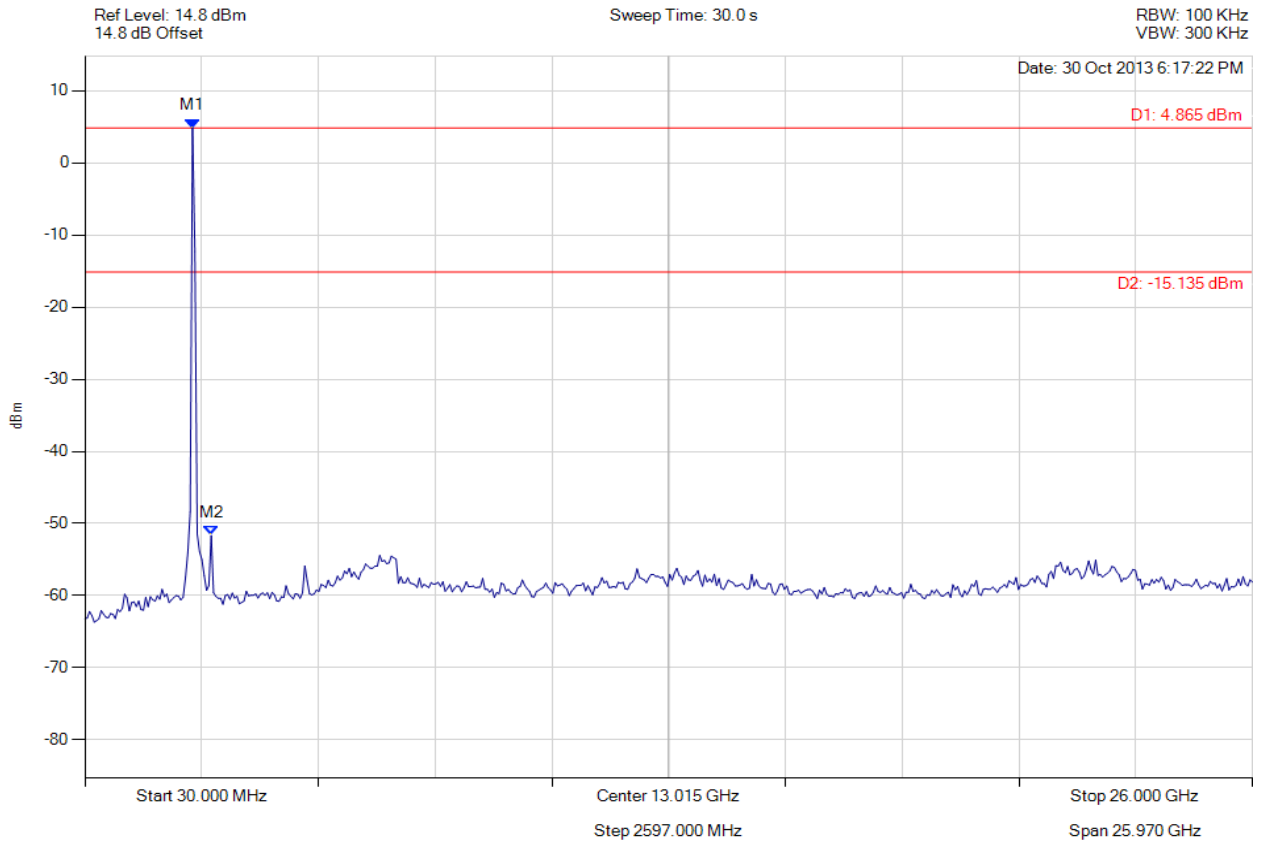

Analyser Setup	Marker : Frequency : Amplitude	Test Results
Detector = MAX PEAK Sweep Count = 0 RF Atten (dB) = 10 Trace Mode = VIEW	M1 : 2424.028 MHz : 4.865 dBm M2 : 2840.381 MHz : -51.669 dBm	Limit: -15.14 dBm Margin: -36.53 dB

[Back to the Matrix](#)

This test report may be reproduced in full only. The document may only be updated by MiCOM Labs personnel. Any changes will be noted in the Document History section of the report.



CONDUCTED SPURIOUS EMISSIONS - PEAK

Variant: 802.11a, Channel: 5745.00 MHz, Chain a, Temp: Ambient, Voltage: 3.6 Vdc

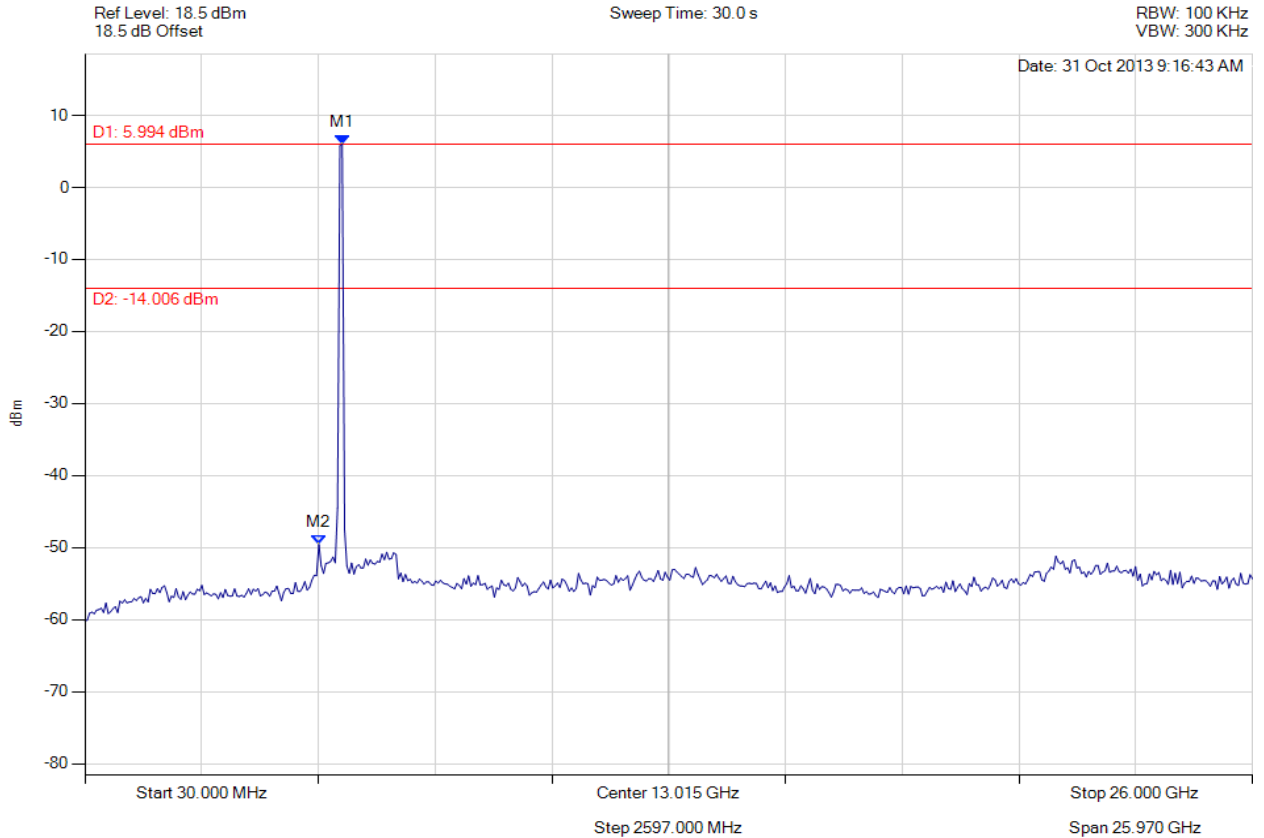

Analyser Setup	Marker : Frequency : Amplitude	Test Results
Detector = MAX PEAK Sweep Count = 0 RF Atten (dB) = 10 Trace Mode = VIEW	M1 : 5754.850 MHz : 5.994 dBm M2 : 5234.409 MHz : -49.565 dBm	Limit: -14.01 dBm Margin: -35.56 dB

[Back to the Matrix](#)

This test report may be reproduced in full only. The document may only be updated by MiCOM Labs personnel. Any changes will be noted in the Document History section of the report.



CONDUCTED SPURIOUS EMISSIONS - PEAK

Variant: 802.11a, Channel: 5785.00 MHz, Chain a, Temp: Ambient, Voltage: 3.6 Vdc

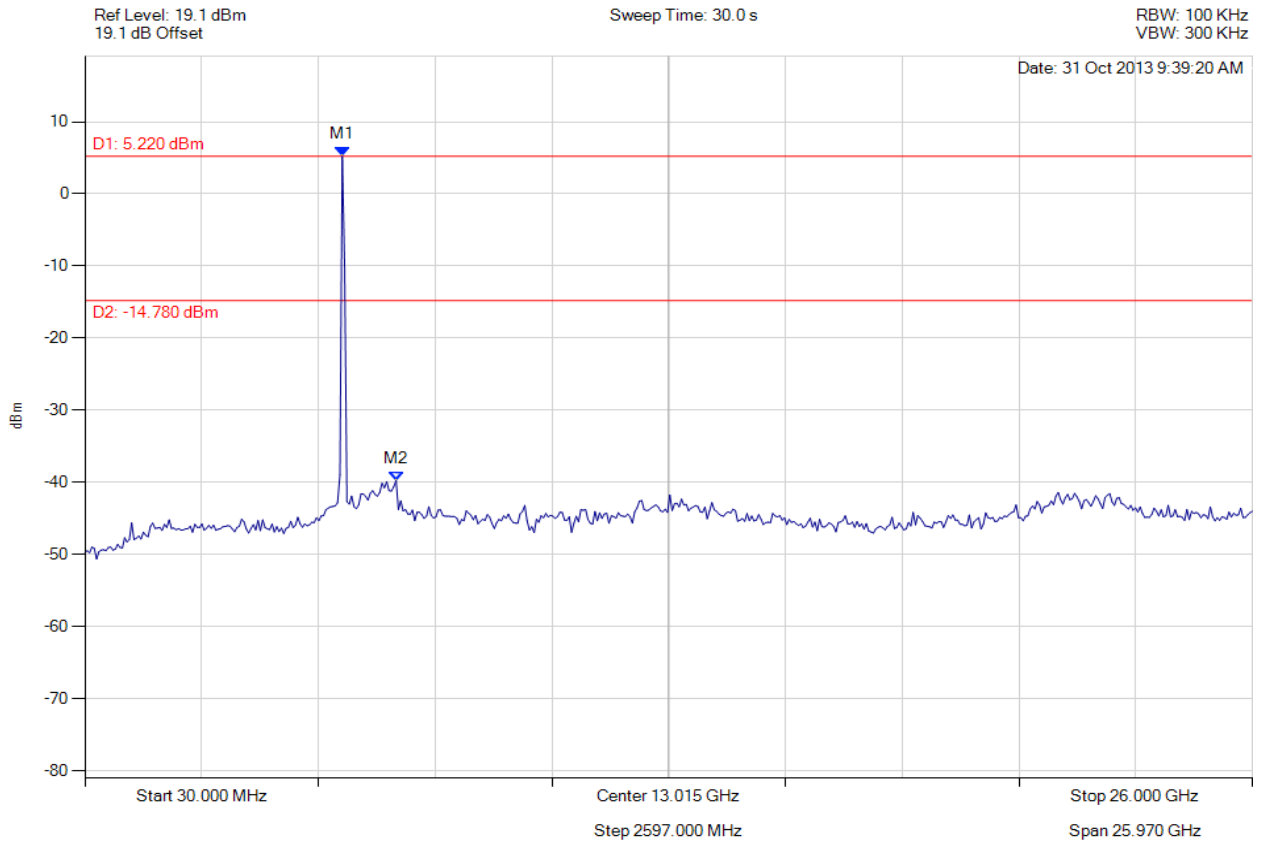

Analyser Setup	Marker : Frequency : Amplitude	Test Results
Detector = MAX PEAK Sweep Count = 0 RF Atten (dB) = 20 Trace Mode = VIEW	M1 : 5754.850 MHz : 5.220 dBm M2 : 6951.864 MHz : -39.738 dBm	Limit: -14.78 dBm Margin: -24.96 dB

[Back to the Matrix](#)

This test report may be reproduced in full only. The document may only be updated by MiCOM Labs personnel. Any changes will be noted in the Document History section of the report.



CONDUCTED SPURIOUS EMISSIONS - PEAK

Variant: 802.11a, Channel: 5825.00 MHz, Chain a, Temp: Ambient, Voltage: 3.6 Vdc

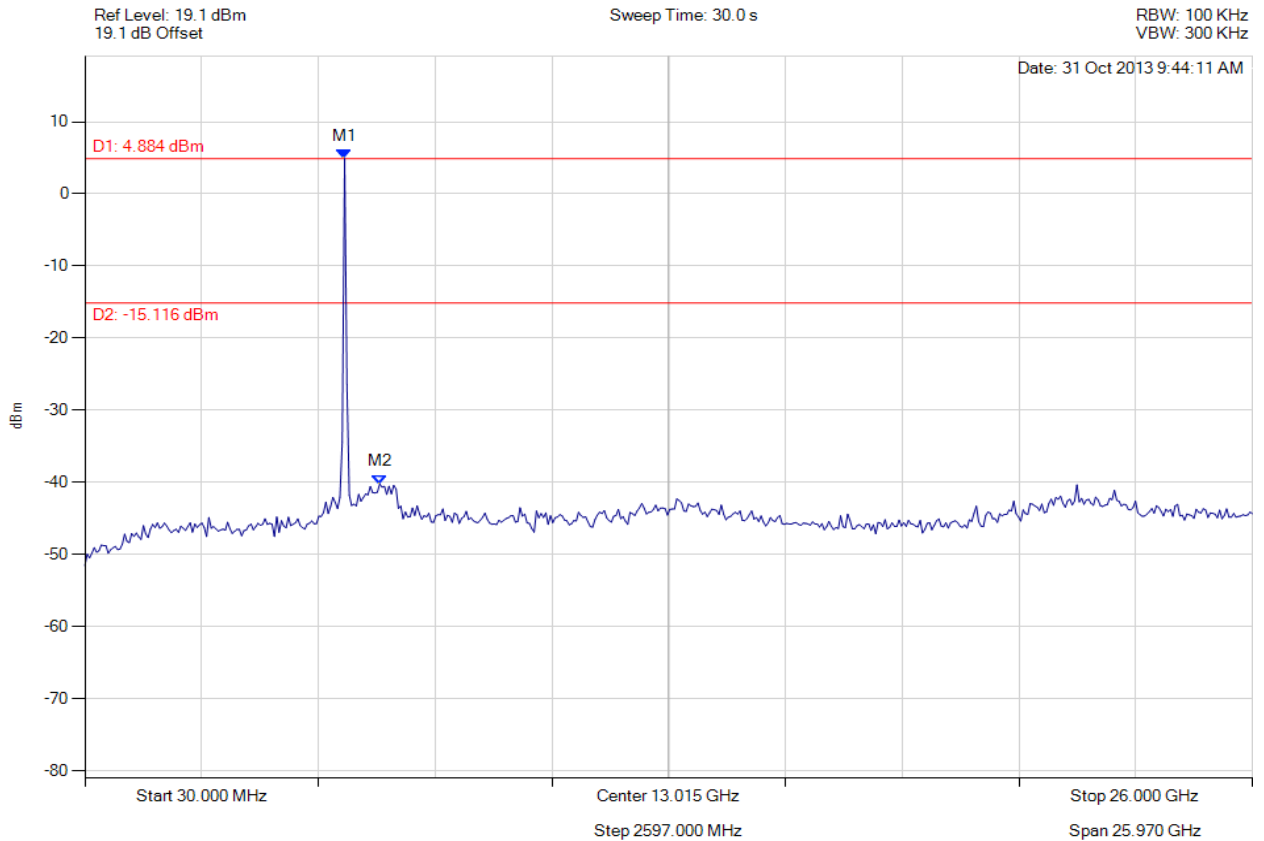

Analyser Setup	Marker : Frequency : Amplitude	Test Results
Detector = MAX PEAK Sweep Count = 0 RF Atten (dB) = 20 Trace Mode = VIEW	M1 : 5806.894 MHz : 4.884 dBm M2 : 6587.555 MHz : -40.212 dBm	Limit: -15.12 dBm Margin: -25.09 dB

[Back to the Matrix](#)

This test report may be reproduced in full only. The document may only be updated by MiCOM Labs personnel. Any changes will be noted in the Document History section of the report.



CONDUCTED SPURIOUS EMISSIONS - PEAK

Variant: 802.11n HT-20, Channel: 5745.00 MHz, Chain a, Temp: Ambient, Voltage: 3.6 Vdc

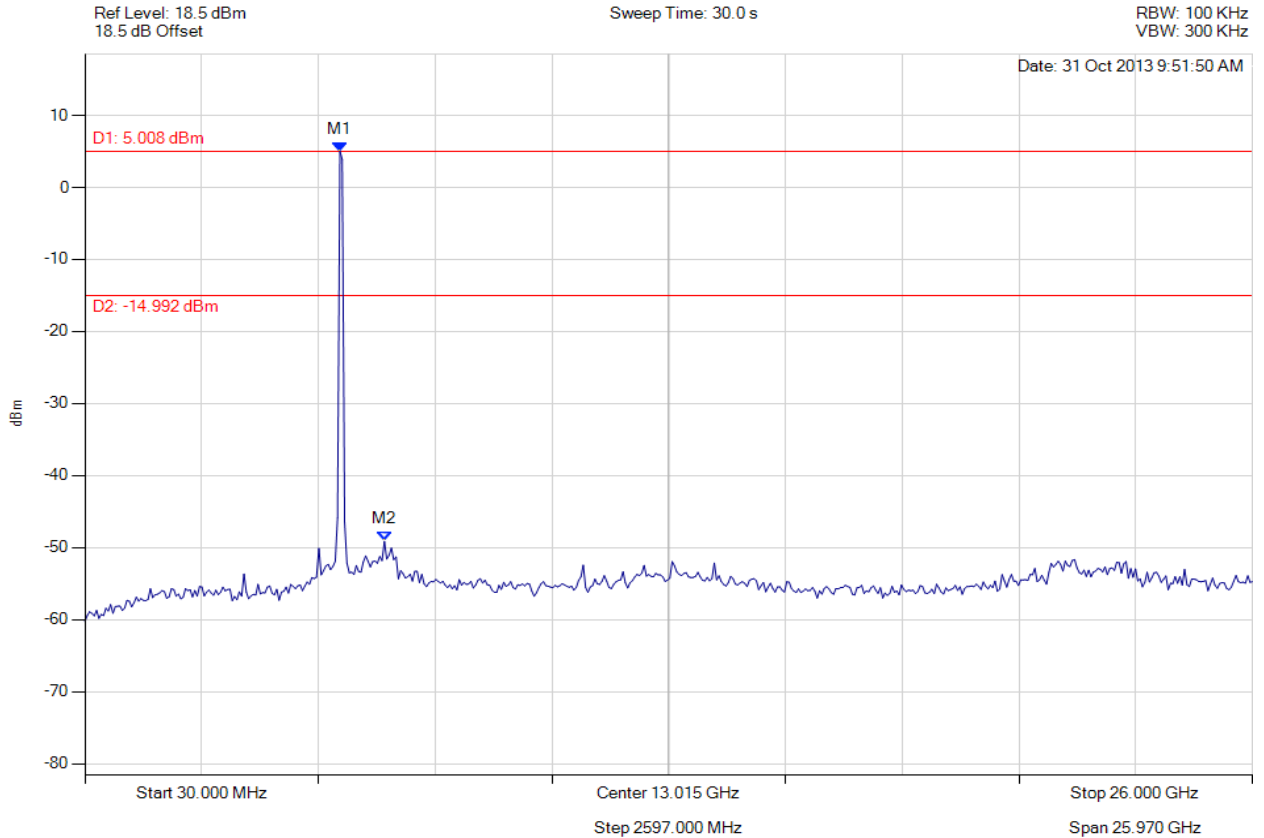

Analyser Setup	Marker : Frequency : Amplitude	Test Results
Detector = MAX PEAK Sweep Count = 0 RF Atten (dB) = 10 Trace Mode = VIEW	M1 : 5702.806 MHz : 5.008 dBm M2 : 6691.643 MHz : -49.140 dBm	Limit: -14.99 dBm Margin: -34.15 dB

[Back to the Matrix](#)

This test report may be reproduced in full only. The document may only be updated by MiCOM Labs personnel. Any changes will be noted in the Document History section of the report.



CONDUCTED SPURIOUS EMISSIONS - PEAK

Variant: 802.11n HT-20, Channel: 5785.00 MHz, Chain a, Temp: Ambient, Voltage: 3.6 Vdc

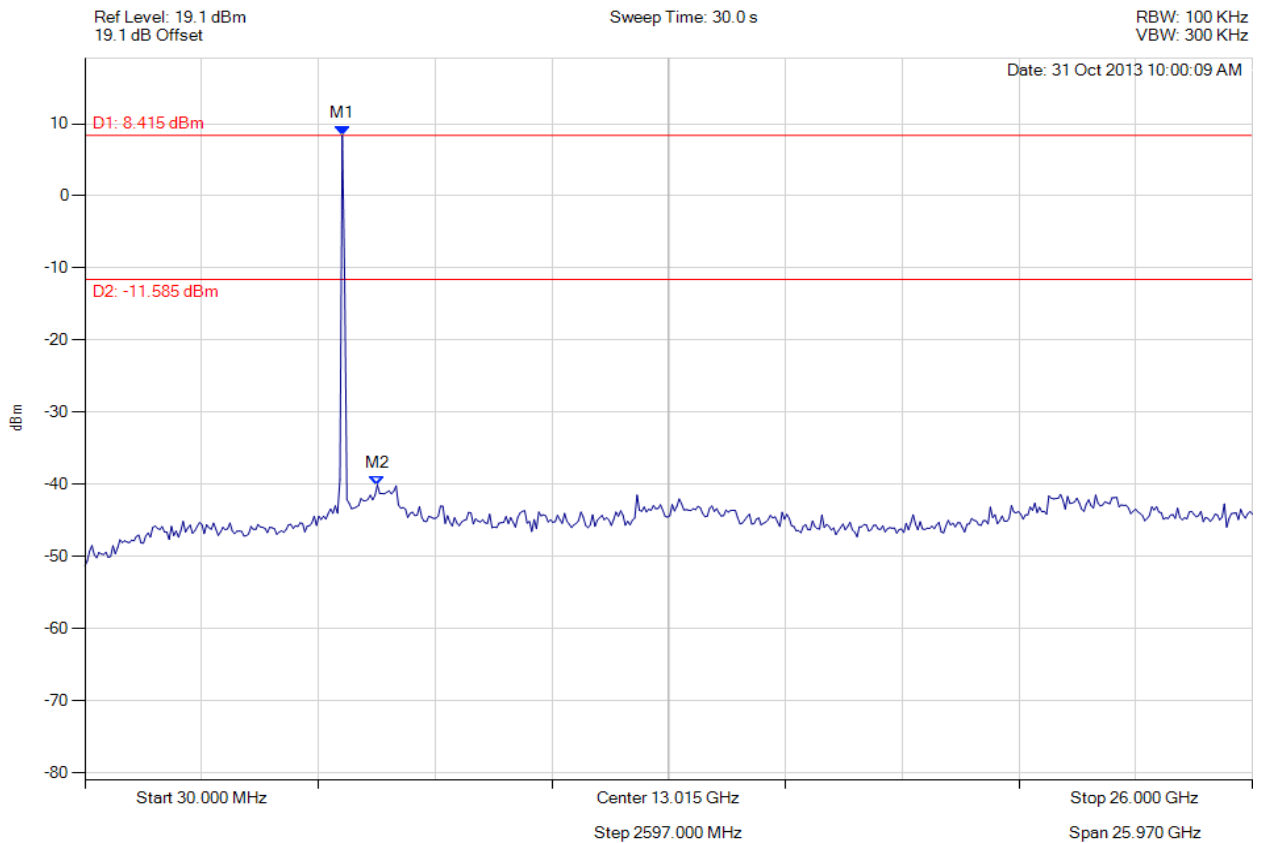

Analyser Setup	Marker : Frequency : Amplitude	Test Results
Detector = MAX PEAK Sweep Count = 0 RF Atten (dB) = 20 Trace Mode = VIEW	M1 : 5754.850 MHz : 8.415 dBm M2 : 6535.511 MHz : -40.084 dBm	Limit: -11.59 dBm Margin: -28.49 dB

[Back to the Matrix](#)

This test report may be reproduced in full only. The document may only be updated by MiCOM Labs personnel. Any changes will be noted in the Document History section of the report.

CONDUCTED SPURIOUS EMISSIONS - PEAK

Variant: 802.11n HT-20, Channel: 5825.00 MHz, Chain a, Temp: Ambient, Voltage: 3.6 Vdc

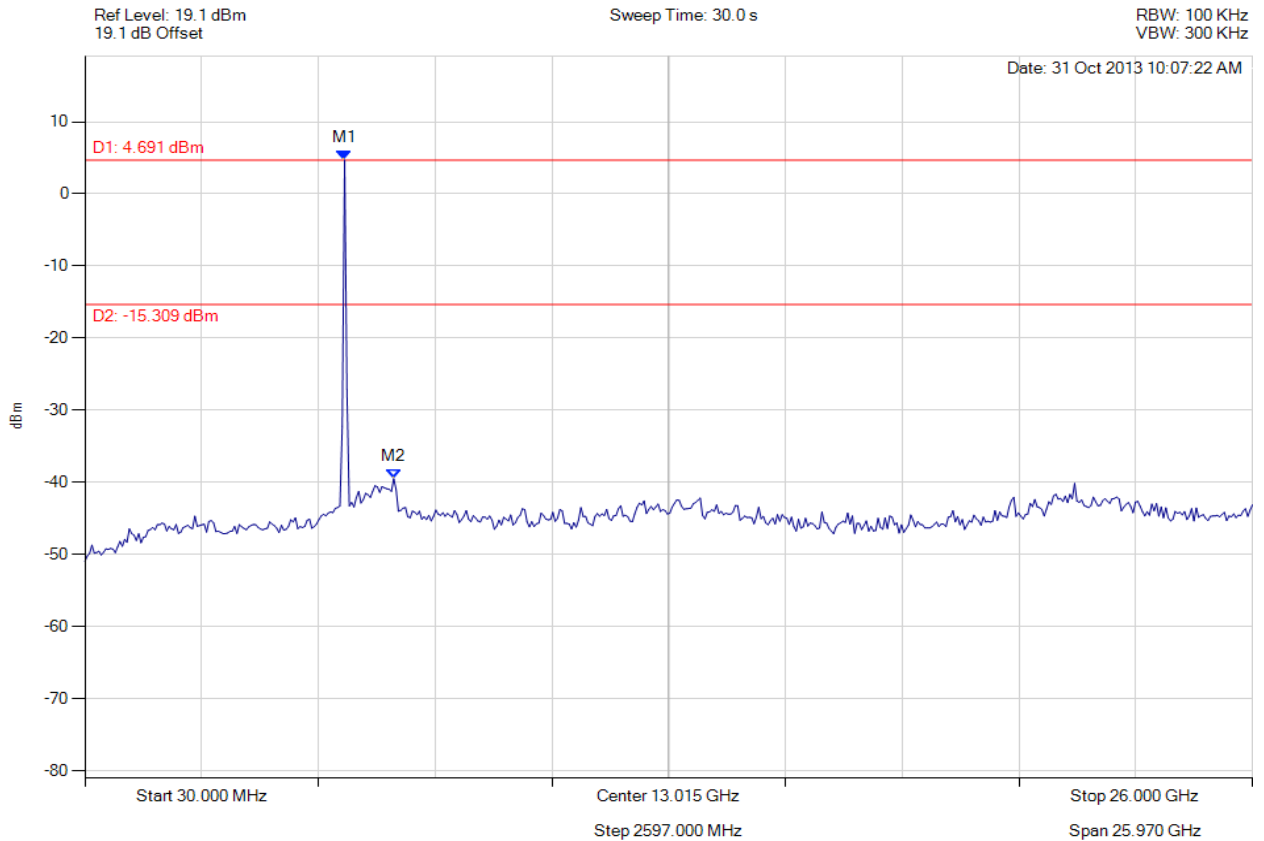

Analyser Setup	Marker : Frequency : Amplitude	Test Results
Detector = MAX PEAK Sweep Count = 0 RF Atten (dB) = 20 Trace Mode = VIEW	M1 : 5806.894 MHz : 4.691 dBm M2 : 6899.820 MHz : -39.476 dBm	Limit: -15.31 dBm Margin: -24.17 dB

[Back to the Matrix](#)

This test report may be reproduced in full only. The document may only be updated by MiCOM Labs personnel. Any changes will be noted in the Document History section of the report.



575 Boulder Court
Pleasanton, CA 94566, USA
Tel: 1.925.462.0304
Fax: 1.925.462.0306
www.micomlabs.com