

Test Report

FCC-ID: IYASDA-BS100

Product Name:	Blind Spot Detection System/ Bar Type
Trademark:	Pioneer
Model Name :	SDA-BS100 SDA-BS100D, SDA-BS101, SDA-BS1, SDA-BS100LP, ND-BS100
Prepared For :	Pioneer Electronics (USA) Inc.
Address :	2050 W. 190th Street, Suite 100, Torrance, CA 90504 USA
Prepared By :	Shenzhen BCTC Testing Co., Ltd.
Address :	BCTC Building & 1-2F, East of B Building, Pengzhou Industrial, Fuyuan 1st Road, Qiaotou Community, Fuyong Street, Bao'an District, Shenzhen, China
Test Date:	Nov. 13, 2019 - Dec. 03, 2019
Date of Report :	Dec. 03, 2019
Report No.:	BCTC1911000890E

CERTIFICATION

Applicant's name: Pioneer Electronics (USA) Inc.
Address.....: 2050 W. 190th Street, Suite 100, Torrance, CA 90504 USA
Manufacture's Name: Pioneer Electronics (USA) Inc.
Address.....: 2050 W. 190th Street, Suite 100, Torrance, CA 90504 USA

Product description

Product name.....: Blind Spot Detection System/ Bar Type
Trademark: Pioneer
SDA-BS100
Model Name: SDA-BS100D, SDA-BS101, SDA-BS1, SDA-BS100LP,
ND-BS100
Test Standards: FCC 47 CFR Part 15, Section 15.245
ANSI C63.10-2013

This device described above has been tested by BCTC, and the test results show that the equipment under test (EUT) is in compliance with the IC requirements. And it is applicable only to the tested sample identified in the report.

This report shall not be reproduced except in full, without the written approval of BCTC, this document may be altered or revised by BCTC, personal only, and shall be noted in the revision of the document.

Test Result.....: **Pass**

Prepared by(Engineer): Cai Fangzhong Cai Fang Zhong

Reviewer(Supervisor): Eric Yang Eric Yang

Approved(Manager): Zero Zhou Zero Zhou



Table of Contents	Page
1 . SUMMARY OF TEST RESULTS	5
1.1 TEST FACILITY	5
1.2 MEASUREMENT UNCERTAINTY	5
2 . GENERAL INFORMATION	6
2.1 GENERAL DESCRIPTION OF EUT	6
2.2 DESCRIPTION OF TEST MODES	7
2.3 TABLE OF PARAMETERS OF TEXT SOFTWARE SETTING	7
2.4 BLOCK DIGRAM SHOWING THE CONFIGURATION OF SYSTEM TESTED	7
2.5 DESCRIPTION OF SUPPORT UNITS(CONDUCTED MODE)	8
2.6 EQUIPMENTS LIST FOR ALL TEST ITEMS	9
3 . EMC EMISSION TEST	10
3.1 CONDUCTED EMISSION MEASUREMENT	10
3.1.1 POWER LINE CONDUCTED EMISSION LIMITS	10
3.1.2 TEST PROCEDURE	11
3.1.3 DEVIATION FROM TEST STANDARD	11
3.1.4 TEST SETUP	11
3.1.5 EUT OPERATING CONDITIONS	11
3.1.6 TEST RESULTS	11
3.2 RADIATED MEASUREMENT.	12
3.2.1 TEST PROCEDURE	12
3.2.2 DEVIATION FROM TEST STANDARD	13
3.2.3 TEST SETUP	13
3.2.4 EUT OPERATING CONDITIONS	14
3.2.5 TEST RESULTS	15
4 . BANDWIDTH TEST	21
4.1 APPLIED PROCEDURES / LIMIT	21
4.1.1 TEST PROCEDURE	21
4.1.2 DEVIATION FROM STANDARD	21
4.1.3 TEST SETUP	21
4.1.4 EUT OPERATION CONDITIONS	21
4.1.5 TEST RESULTS	22
5 . ANTENNA REQUIREMENT	23
5.1 STANDARD REQUIREMENT	23
5.2 EUT ANTENNA	23



Table of Contents	Page
6 . EUT TEST PHOTO	24
7 . PHOTOS OF THE EUT	26

1. SUMMARY OF TEST RESULTS

Test procedures according to the technical standards:

FCC 47 CFR Part 15, Subpart C, Section 15.245			
Standard Section	Test Item	Judgment	Remark
15.245 (b)	Fundamental Radiated	PASS	
15.245 (b)	Spurious Emission Measurement	PASS	
15.215 (c)	Bandwidth	PASS	
15.205 (a)	Band Edge Emission	PASS	

NOTE:

(1) "N/A" denotes test is not applicable in this Test Report

1.1 TEST FACILITY

Shenzhen BCTC Testing Co., Ltd.

Add. : BCTC Building & 1-2F, East of B Building, Pengzhou Industrial, Fuyuan 1st Road, Qiaotou Community, Fuyong Street, Bao'an District, Shenzhen, China

FCC Test Firm Registration Number: 712850

IC Registered No.: 23583

1.2 MEASUREMENT UNCERTAINTY

The reported uncertainty of measurement $y \pm U$, where expanded uncertainty U is based on a standard uncertainty multiplied by a coverage factor of $k=2$, providing a level of confidence of approximately **95 %**.

No.	Item	Uncertainty
1	Conducted Emission Test	$\pm 1.38\text{dB}$
2	RF power, conducted	$\pm 0.16\text{dB}$
3	Spurious emissions, conducted	$\pm 0.21\text{dB}$
4	All emissions, radiated (<1G)	$\pm 4.68\text{dB}$
5	All emissions, radiated (>1G)	$\pm 4.89\text{dB}$
6	Temperature	$\pm 0.5^\circ\text{C}$
7	Humidity	$\pm 2\%$

2. GENERAL INFORMATION

2.1 GENERAL DESCRIPTION OF EUT

Equipment	ADD-ON BLIND SPOT DETECTION SYSTEM LICENSE PLATE BAR TYPE FOR UNIVERSAL APPLICATION	
Trade Name	Pioneer	
Model Name	SDA-BS100	
Serial Model	SDA-BS100D, SDA-BS101, SDA-BS1, SDA-BS100LP, ND-BS100	
Model Difference	Consecutive Model Years and sales territories	
Product Description	Operation Frequency:	24089MHz
	Bit Rate of Transmitter	1Mbps
	Number Of Channel	1CH
	Max. RF Output Power:	106.23 dBuV/m
	Antenna Designation:	Please see Note 3.
	Based on the application, features, or specification exhibited in User's Manual, the EUT is considered as an ITE/Computing Device. More details of EUT technical specification, please refer to the User's Manual.	
Channel List	Please refer to the Note 2.	
Power Supply	DC 12V 0.4A	
Connecting I/O Port(s)	Please refer to the User's Manual	
Hardware Version:	SB236A18	
Software Version:	SB236A07-V9-test1	
Power level set	10dBm	

Note:

1. For a more detailed features description, please refer to the manufacturer's specifications or the User's Manual.
- 2.

Channel List					
Channel	Frequency (MHz)	Channel	Frequency (MHz)	Channel	Frequency (MHz)
01	24089	\	\	\	\

3. Table for Filed Antenna

Ant.	Brand	Model Name	Antenna Type	Gain (dBi)	NOTE
1	N/A	N/A	PCB Antenna	7.1	

2.2 DESCRIPTION OF TEST MODES

To investigate the maximum EMI emission characteristics generates from EUT, the test system was pre-scanning tested base on the consideration of following EUT operation mode or test configuration mode which possible have effect on EMI emission level. Each of these EUT operation mode(s) or test configuration mode(s) mentioned above was evaluated respectively.

For Conducted & Radiated Emission	
Final Test Mode	Description
Mode 1	CH01 Transmitting

Note:

- (1) The measurements are performed at the highest, middle, lowest available channels.
- (2) Fully-charged battery is used during the test

2.3 TABLE OF PARAMETERS OF TEXT SOFTWARE SETTING

During testing channel & power controlling software provided by the customer was used to control the operating channel as well as the output power level. The RF output power selection is for the setting of RF output power expected by the customer and is going to be fixed on the firmware of the final end product power parameters.

Frequency	24089 MHz
Channel	01

2.4 BLOCK DIGRAM SHOWING THE CONFIGURATION OF SYSTEM TESTED

Radiated Spurious Emission/Conducted Emission Test

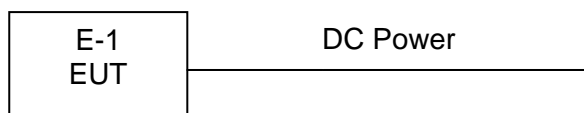

2.5 DESCRIPTION OF SUPPORT UNITS(CONDUCTED MODE)

The EUT has been tested as an independent unit together with other necessary accessories or support units. The following support units or accessories were used to form a representative test configuration during the tests.

Item	Equipment	Mfr/Brand	Model/Type No.	Series No.	Note
E-1	Blind Spot Detection System/ Bar Type	Pioneer	SDA-BS100	N/A	EUT
E-2	DC Power	N/A	N/A	N/A	Auxiliary

Item	Shielded Type	Ferrite Core	Length	Note
C1	NO	NO	2.5M	DC cable unshielded

Note:

- (1) The support equipment was authorized by Declaration of Confirmation.
- (2) For detachable type I/O cable should be specified the length in cm in 『Length』 column.
- (3) “YES” is means “shielded” “with core”; “NO” is means “unshielded” “without core”.

2.6 EQUIPMENTS LIST FOR ALL TEST ITEMS

Radiation Test equipment

Item	Equipment	Manufacturer	Type No.	Serial No.	Last calibration	Calibrated until
1	Spectrum Analyzer (9kHz-26.5GHz)	Agilent	E4407B	MY45109572	2019.06.13	2020.06.12
2	Test Receiver (9kHz-7GHz)	R&S	ESR7	101154	2019.06.13	2020.06.12
3	Bilog Antenna (30MHz-3GHz)	SCHWARZBEC K	VULB9163	VULB9163-942	2019.06.22	2020.06.21
4	Horn Antenna (1GHz-18GHz)	SCHWARZBEC K	BBHA9120D	1541	2019.06.22	2020.06.21
5	Horn Antenna (18GHz-40GHz)	SCHWARZBEC K	BBHA9170	822	2019.06.22	2020.06.21
6	Amplifier (9kHz-6GHz)	SCHWARZBEC K	BBV9744	9744-0037	2019.06.25	2020.06.24
7	Amplifier (0.5GHz-18GHz)	SCHWARZBEC K	BBV9718	9718-309	2019.06.25	2020.06.24
8	Amplifier (18GHz-40GHz)	MITEQ	TTA1840-35-H G	2034381	2019.06.17	2020.06.16
9	Loop Antenna (9kHz-30MHz)	SCHWARZBEC K	FMZB1519B	014	2019.06.25	2020.06.24
10	RF cables1 (9kHz-30MHz)	Huber+Suhnar	9kHz-30MHz	B1702988-0008	2019.06.25	2020.06.24
11	RF cables2 (30MHz-1GHz)	Huber+Suhnar	30MHz-1GHz	1486150	2019.06.25	2020.06.24
12	RF cables3 (1GHz-40GHz)	Huber+Suhnar	1GHz-40GHz	1607106	2019.06.25	2020.06.24
13	Power Metter	Keysight	E4419	\	2019.06.17	2020.06.16
14	Power Sensor (AV)	Keysight	E9 300A	\	2019.06.17	2020.06.16
15	Spectrum Analyzer 20kHz-26.5GHz	KEYSIGHT	N9020A	MY49100060	2019.06.13	2020.06.12
16	Spectrum Analyzer 9kHz-40GHz	R&S	FSP40	100363	2019.06.13	2020.06.12
17	D.C. Power Supply	LongWei	TPR-6405D	\	\	\
18	Software	Frad	EZ-EMC	FA-03A2 RE	\	\

3. EMC EMISSION TEST

3.1 CONDUCTED EMISSION MEASUREMENT

3.1.1 POWER LINE CONDUCTED EMISSION Limits (Frequency Range 150KHz-30MHz)

FREQUENCY (MHz)	Limit (dBuV)		Standard
	Quasi-peak	Average	
0.15 -0.5	66 - 56 *	56 - 46 *	FCC
0.50 -5.0	56.00	46.00	FCC
5.0 -30.0	60.00	50.00	FCC

Note:

- (1) The tighter limit applies at the band edges.
- (2) The limit of " * " marked band means the limitation decreases linearly with the logarithm of the frequency in the range.

The following table is the setting of the receiver

Receiver Parameters	Setting
Attenuation	10 dB
Start Frequency	0.15 MHz
Stop Frequency	30 MHz
IF Bandwidth	9 kHz

3.1.2 TEST PROCEDURE

- a. The EUT was placed 0.8 meters from the horizontal ground plane with EUT being connected to the power mains through a line impedance stabilization network (LISN). All other support equipments powered from additional LISN(s). The LISN provide 50 Ohm/ 50uH of coupling impedance for the measuring instrument.
- b. Interconnecting cables that hang closer than 40 cm to the ground plane shall be folded back and forth in the center forming a bundle 30 to 40 cm long.
- c. I/O cables that are not connected to a peripheral shall be bundled in the center. The end of the cable may be terminated, if required, using the correct terminating impedance. The overall length shall not exceed 1 m.
- d. LISN at least 80 cm from nearest part of EUT chassis.
- e. For the actual test configuration, please refer to the related Item –EUT Test Photos.

3.1.3 DEVIATION FROM TEST STANDARD

No deviation

3.1.4 TEST SETUP

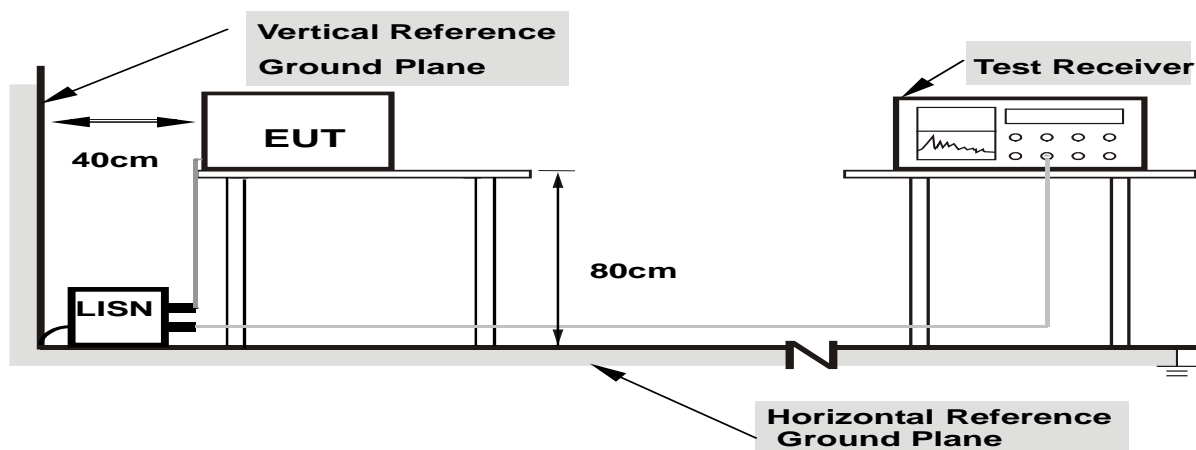

- Note: 1.Support units were connected to second LISN.**
2.Both of LISNs (AMN) are 80 cm from EUT and at least 80 from other units and other metal planes

3.1.5 EUT OPERATING CONDITIONS

The EUT was configured for testing in a typical fashion (as a customer would normally use it). The EUT has been programmed to continuously transmit during test. This operating condition was tested and used to collect the included data.

We pretest AC 120V and AC 240V, the worst voltage was AC 120V and the data recording in the report.

3.1.6 TEST RESULTS

N/A

3.2 RADIATED MEASUREMENT.

Applicable Standard

According to 15.245 (b): Additionally, harmonic emissions falling into restricted bands listed in ANSI C63.10, which are below 17.7 GHz shall meet the general field strength limits specified in ANSI C63.10 .

According to 15.245 (b): Harmonic emissions falling into restricted bands listed in ANSI C63.10 and which are at and (c)above 17.7 GHz shall not exceed the following field strength limits measured at a distance of 3 m.

According to 15.245 (b): Emissions radiated outside of the specified frequency bands, except for harmonic (e)emissions, shall be attenuated by at least 50 dB below the level of the fundamental emissions or to the general field strength limits specified in ANSI C63.10 , whichever is less stringent.

Table F1 — Field Strengths for Field Disturbance Sensors Operating at Different Frequencies

Fundamental frequency	Field strength of fundamental (millivolts/meter)	Field strength of harmonics (millivolts/meter)
902-928 MHz	500	1.6
2435-2465 MHz	500	1.6
5785-5815 MHz	500	1.6
10500-10550 MHz	2500	25.0
24075-24175 MHz	2500	25.0

As per 15.245 (b), The average field strength measured at 3 m shall not exceed the limits shown in Table.

3.2.1 TEST PROCEDURE

- The EUT is placed on a turntable, which is 1.5 m above ground plane.
- The turntable shall be rotated for 360 degrees to determine the position of maximum emission level.
- In case from 9 kHz to 18 GHz, EUT is set 3 m away from the receiving antenna, which is varied from 1m to 4m to find out the highest emissions. In case from 18 GHz to 40 GHz, EUT is set 1 m away from the receiving antenna, which is varied from 1m to 4m to find out the highest emissions.
- The initial step in collecting conducted emission data is a spectrum analyzer peak detector mode pre-scanning the measurement frequency range. Significant peaks are then marked and then Quasi Peak detector mode re-measured.
- Maximum procedure was performed on the six highest emissions to ensure EUT compliance.
- And also, each emission was to be maximized by changing the polarization of receiving antenna both horizontal and vertical.
- Repeat above procedures until the measurements for all frequencies are complete.

3.2.2 DEVIATION FROM TEST STANDARD

No deviation

3.2.3 TEST SETUP

(A) Radiated Emission Test-Up Frequency Below 30MHz

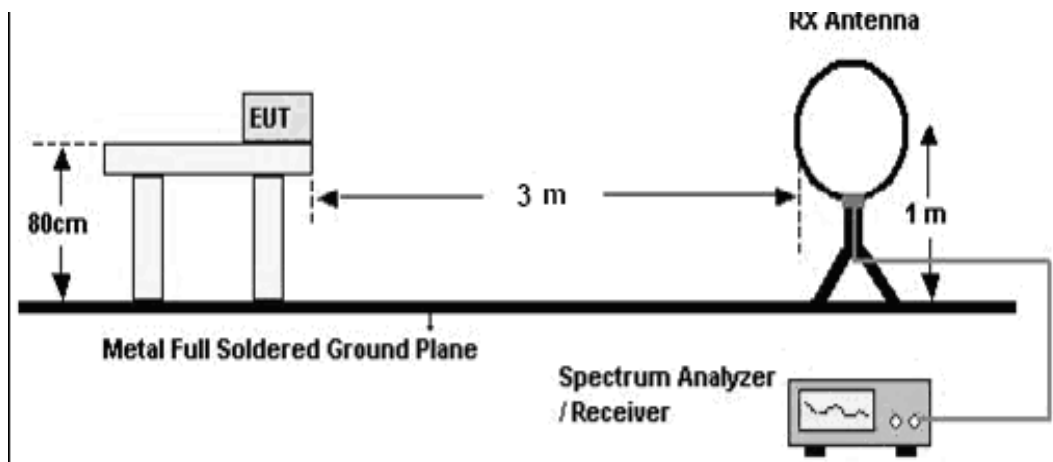

(B) Radiated Emission Test-Up Frequency 30MHz~1GHz

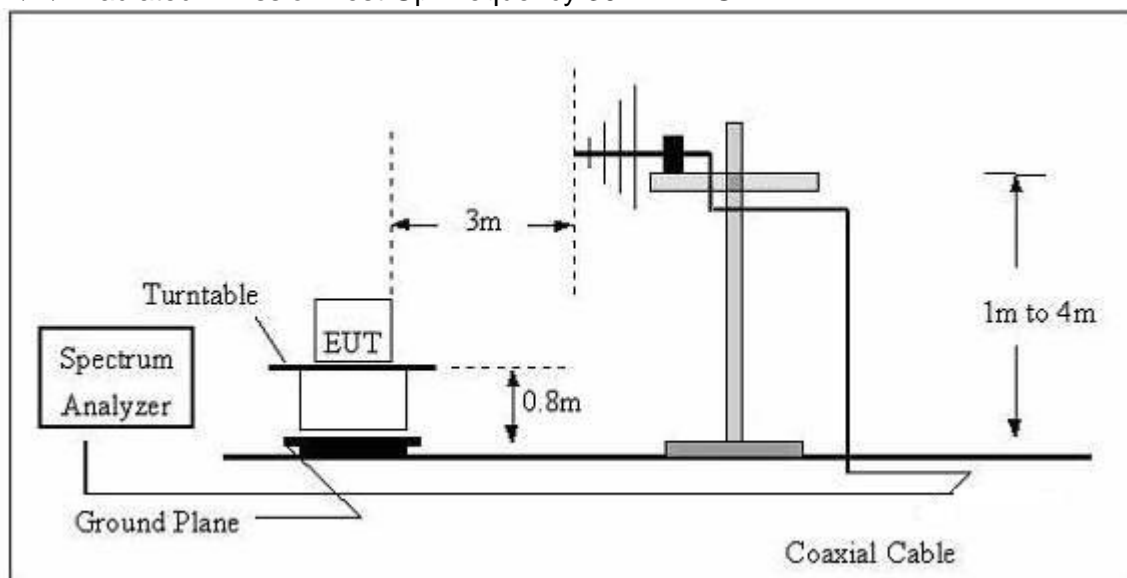

(C) Radiated Emission Test-Up Frequency Above 1GHz

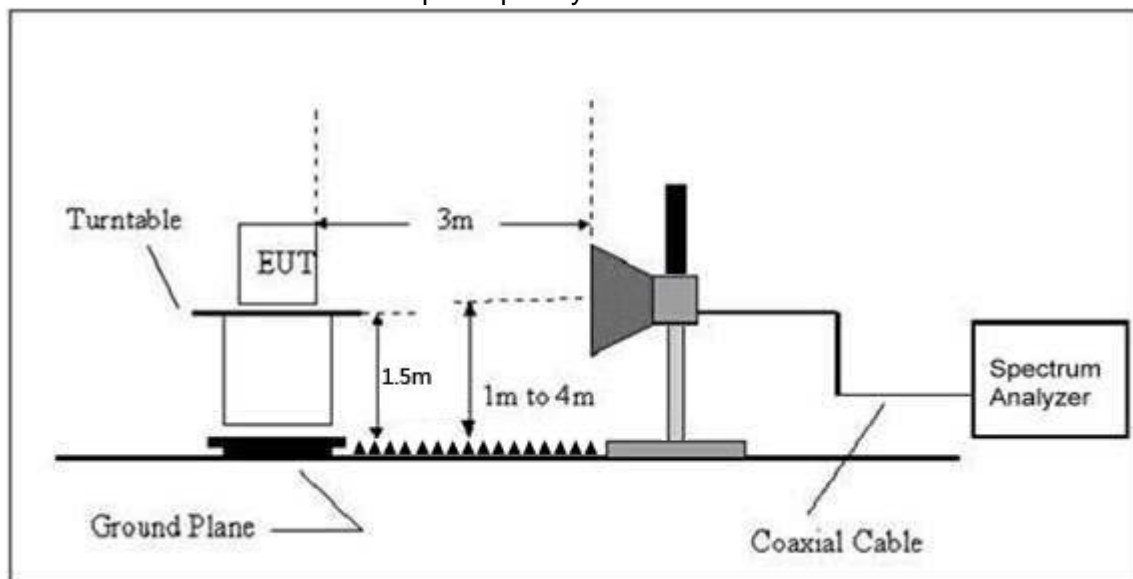

3.2.4 EUT OPERATING CONDITIONS

The EUT tested system was configured as the statements of 2.4 Unless otherwise a special operating condition is specified in the follows during the testing.

3.2.5 TEST RESULTS

FIELD STRENGTH OF FUNDAMENTAL TEST RESULTS

Polar (H/V)	Frequency	Meter Reading	A.F+C.L	D.E.F	Total	Limits	Margin	Detector Type
	(MHz)	(dBuV)	(dB)	(dB)	(dBuV/m)	(dBuV/m)	(dB)	
V	24089	74.31	41.36	-9.46	106.21	147.96	-41.75	PK
V	24089	74.28	41.36	-9.46	106.18	127.96	-21.78	AV
H	24089	74.33	41.36	-9.46	106.23	147.96	-41.73	PK
H	24089	74.18	41.36	-9.46	106.08	127.96	-21.88	AV

A·F: ANTENNA FACTOR

C·L: CABLE LOSS

Note :

1. Total = Reading Value + Antenna Factor + Cable Loss + Distance Factor
2. Distance extrapolation factor = 20 log (test distance / specific distance) (dB)

FIELD STRENGTH OF HARMONICS and RADIATED SPURIOUS EMISSIONS TEST RESULTS

Radiated Spurious Emission (Below 30MHz)

EUT :	Blind Spot Detection System/ Bar Type	Model Name :	SDA-BS100
Temperature :	20 °C	Relative Humidity :	48%
Pressure :	1010 hPa	Polarization :	---
Test Voltage :	DC 12V		
Test Mode :	Mode 1		

Freq.	Reading	Limit	Margin	State
(MHz)	(dBuV/m)	(dBuV/m)	(dB)	P/F
--	--	--	--	PASS
--	--	--	--	PASS

NOTE:

The amplitude of spurious emissions which are attenuated by more than 20dB below the permissible value has no need to be reported.

Distance extrapolation factor = 40 log (specific distance/test distance)(dB);

Limit line = specific limits(dBuV) + distance extrapolation factor.

Radiated Spurious Emission (Between 30MHz – 1GHz)

EUT :	Blind Spot Detection System/ Bar Type	Model Name :	SDA-BS100
Temperature :	25 °C	Relative Humidity :	55%
Pressure :	101kPa	Polarization :	Horizontal
Test Voltage :	DC 12V		
Test Mode :	Model 1		

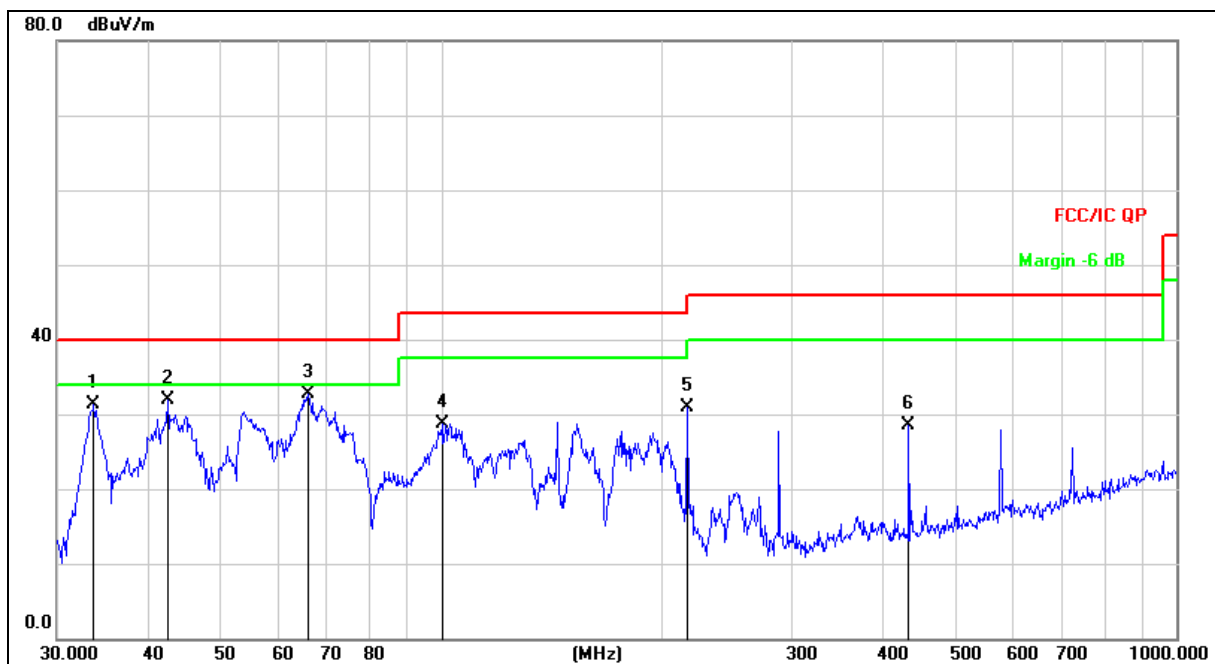

Remark:

Factor = Antenna Factor + Cable Loss – Pre-amplifier.

No.	Mk.	Freq. MHz	Reading Level dBuV	Correct Factor dB	Measure- ment dBuV/m	Limit dB/m	Over dB	Detector
1		33.6802	47.95	-16.59	31.36	40.00	-8.64	QP
2		42.4508	47.19	-15.27	31.92	40.00	-8.08	QP
3	*	65.8031	49.99	-17.23	32.76	40.00	-7.24	QP
4		100.2286	45.07	-16.29	28.78	43.50	-14.72	QP
5		216.0240	46.81	-15.93	30.88	46.00	-15.12	QP
6		432.5457	38.80	-10.36	28.44	46.00	-17.56	QP

EUT :	Blind Spot Detection System/ Bar Type	Model Name :	SDA-BS100
Temperature :	26 °C	Relative Humidity :	54%
Pressure :	101kPa	Polarization :	Vertical
Test Voltage :	DC 12V		
Test Mode :	Model 1		

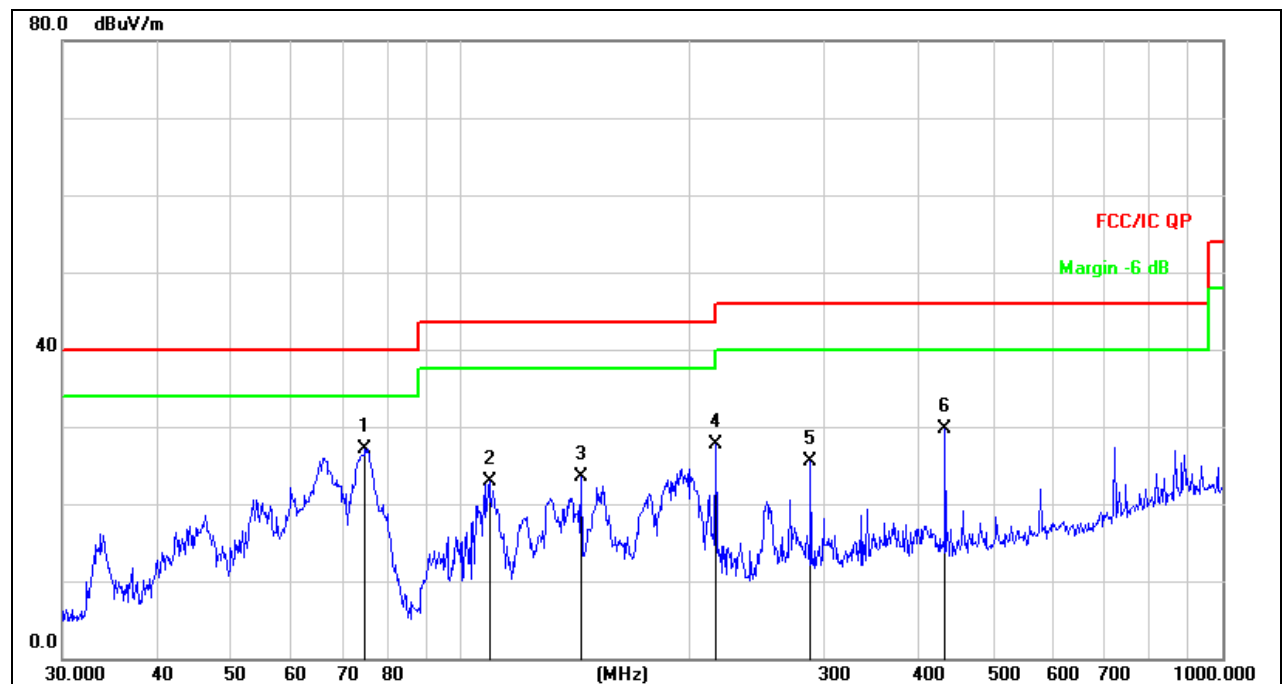

Remark:

Factor = Antenna Factor + Cable Loss – Pre-amplifier.

No.	Mk.	Freq. MHz	Reading Level dBuV	Correct Factor dB	Measure- ment dBuV/m	Limit dB/m	Over dB	Detector
1	*	74.9191	46.47	-19.28	27.19	40.00	-12.81	QP
2		109.0286	39.82	-16.86	22.96	43.50	-20.54	QP
3		143.8295	42.63	-19.10	23.53	43.50	-19.97	QP
4		216.0240	43.61	-15.93	27.68	46.00	-18.32	QP
5		287.9904	39.41	-13.97	25.44	46.00	-20.56	QP
6		432.5457	39.97	-10.36	29.61	46.00	-16.39	QP

Radiated Spurious Emission (Between 1GHz – 18GHz)

EUT :	Blind Spot Detection System/ Bar Type	Model Name :	SDA-BS100
Temperature :	26 °C	Relative Humidity :	54%
Pressure :	1010 hPa	Polarization :	Vertical
Test Voltage :	DC 12V (form adapter)		
Test Mode : (Worst)	Mode 1		

Between 1-18GHz

Polar (H/V)	Frequency (MHz)	Meter Reading (dBuV)	Pre-amplifier (dB)	Cable Loss (dB)	Antenna Factor (dB)	Emission Level (dBuV/m)	Limits (dBuV/m)	Margin (dB)	Detector Type
Channel:24089MHz									
V	1636.7	51.63	39.55	7.77	25.66	57.75	74.00	-16.25	Pk
V	1636.7	43.12	39.55	7.77	25.66	49.24	54.00	-4.76	AV
V	3065.8	50.38	38.33	7.3	24.55	56.86	74.00	-17.14	Pk
V	3065.8	43.6	38.33	7.3	24.55	50.08	54.00	-3.92	AV
H	4986.4	50.11	38.78	7.35	24.54	57.00	74.00	-17.00	Pk
H	4986.4	43.63	38.78	7.35	24.54	50.52	54.00	-3.48	AV
H	7065.2	50.82	38.65	7.15	24.52	57.80	74.00	-16.20	Pk
H	7065.2	43.57	38.65	7.15	24.52	50.55	54.00	-3.45	AV
H	10253.4	52.16	36.68	6.42	26.47	55.95	74.00	-18.05	Pk
H	10253.4	41.33	36.68	6.42	26.47	45.12	54.00	-8.88	AV
V	17620.6	54.67	36.42	8.62	26.45	56.02	74.00	-17.98	Pk
V	17620.6	44.72	36.42	8.62	26.45	46.07	54.00	-7.93	AV

NOTE:

Distance extrapolation factor = $20 \log(\text{specific distance}/\text{test distance})$ (dB);
 Limit line = specific limits(dBuv) + distance extrapolation factor.

Radiated Spurious Emission (18GHz-40GHz)

Polar (H/V)	Frequency	Meter Reading	A.F+C.L	D.E.F	Total	Limits	Margin	Detector Type
	(MHz)	(dBuV)	(dB)	(dB)	(dBuV/m)	(dBuV/m)	(dB)	
V	*24075	32.03	41.36	-9.46	63.93	74	-10.07	PK
V	*24075	9.73	41.36	-9.46	41.63	54	-12.37	AV
V	*24175	33.55	41.36	-9.46	65.45	74	-8.55	PK
V	*24175	10.06	41.36	-9.46	41.96	54	-12.04	AV

A·F: ANTENNA FACTOR

C·L: CABLE LOSS

Note :

1. Total = Reading Value + Antenna Factor + Cable Loss + Distance Factor
2. Distance extrapolation factor = $20 \log(\text{test distance} / \text{specific distance})$ (dB)
3. We have done x, y, z planes in EUT and horizontal and vertical polarization in detecting antenna.
Worst case is y plane and vertical polarization.
4. '*' is band edge frequency.

Band Edge Plot (Y-V)

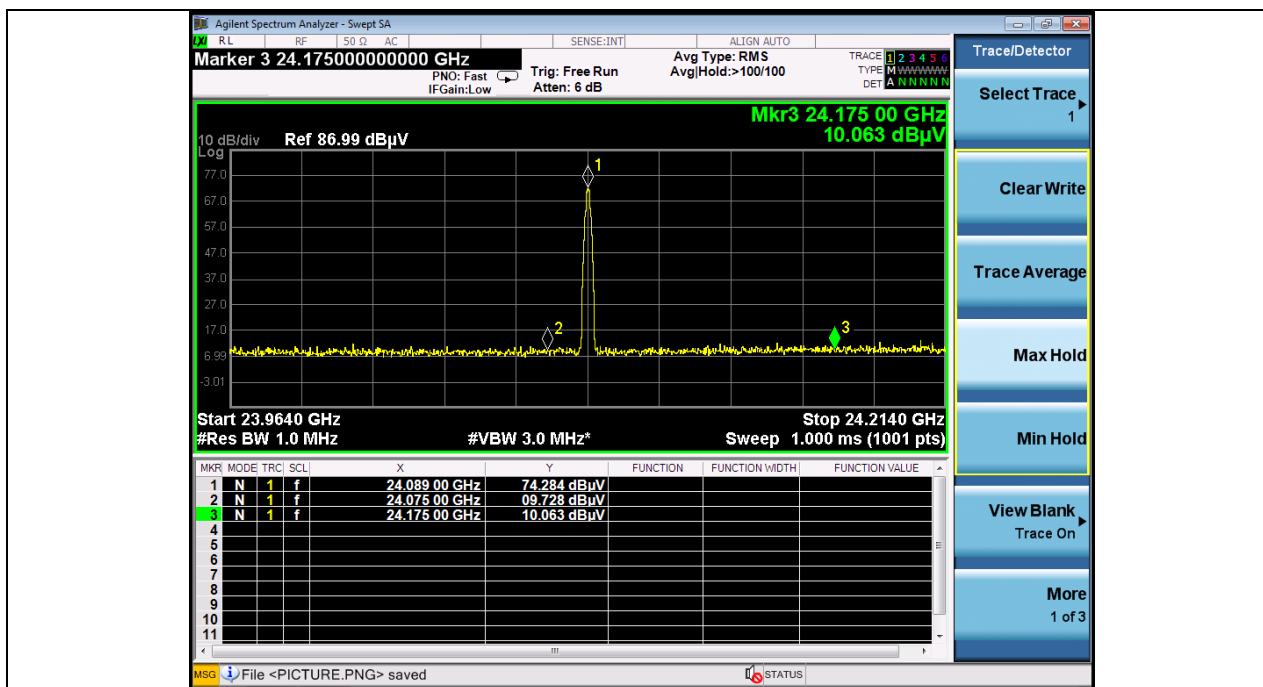

4. BANDWIDTH TEST

4.1 APPLIED PROCEDURES / LIMIT

15.215 (c)				
Section	Test Item	Limit	Frequency Range (MHz)	Result
15.215 (c)	Bandwidth	OBW	24075-24175	PASS

Spectrum Parameter	Setting
Attenuation	Auto
Span Frequency	> Measurement Bandwidth or Channel Separation
RB	1KHz
VB	\geq RBW
Detector	Peak
Trace	Max Hold
Sweep Time	Auto

4.1.1 TEST PROCEDURE

- a. The EUT was directly connected to the spectrum analyzer and antenna output port as show in the block diagram below,
- b. Spectrum Setting : RBW= 100KHz, VBW \geq RBW, Sweep time = Auto.

4.1.2 DEVIATION FROM STANDARD

No deviation.

4.1.3 TEST SETUP



4.1.4 EUT OPERATION CONDITIONS

The EUT tested system was configured as the statements of 2.4 Unless otherwise a special operating condition is specified in the follows during the testing.

4.1.5 TEST RESULTS

EUT :	Blind Spot Detection System/ Bar Type	Model Name :	SDA-BS100
Temperature :	25 °C	Relative Humidity :	55%
Pressure :	1012 hPa	Test Voltage :	DC 12V
Test Mode :	CH01		

Frequency	20dB Bandwidth (MHz)	99% Bandwidth (MHz)	Result
24089MHz	2.323	2.0202	PASS

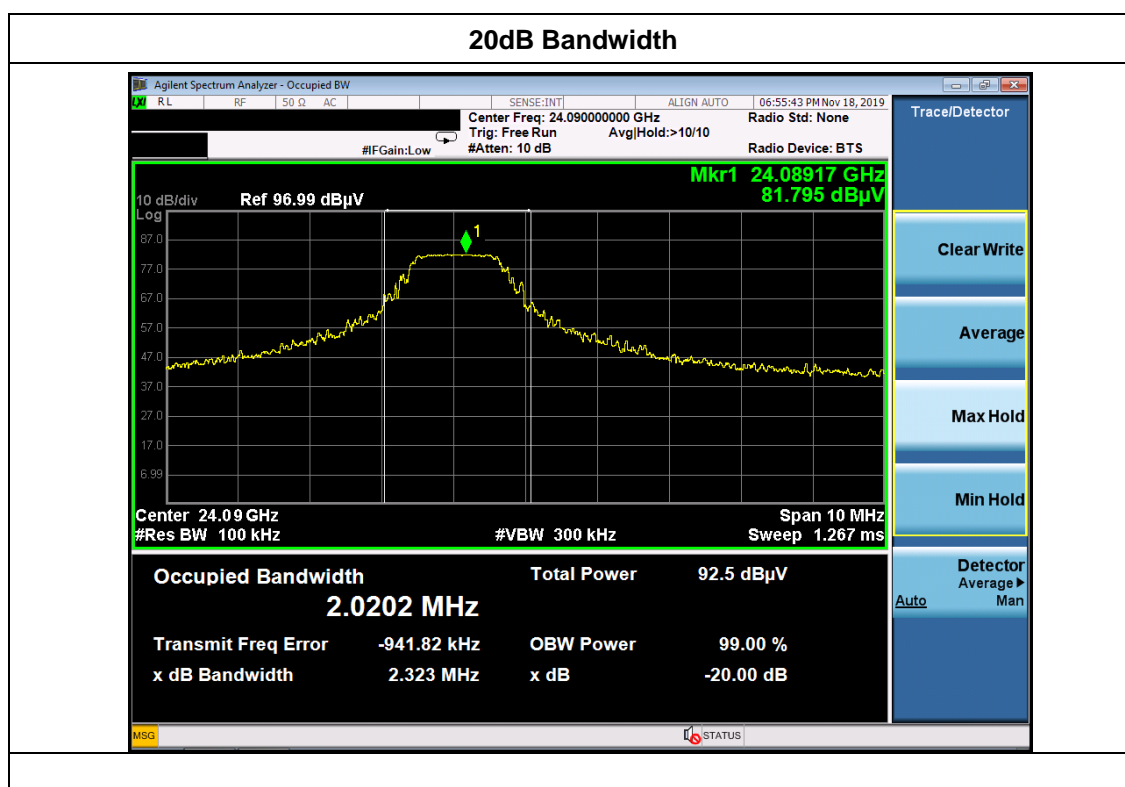

5. ANTENNA REQUIREMENT

5.1 STANDARD REQUIREMENT

15.203 requirement: For intentional device, according to 15.203: an intentional radiator shall be designed to ensure that no antenna other than that furnished by the responsible party shall be used with the device.

5.2 EUT ANTENNA

The EUT antenna is Internal antenna, fulfill the requirement of this section.

6. EUT TEST PHOTO

Radiated Measurement Photos 30-1GHz

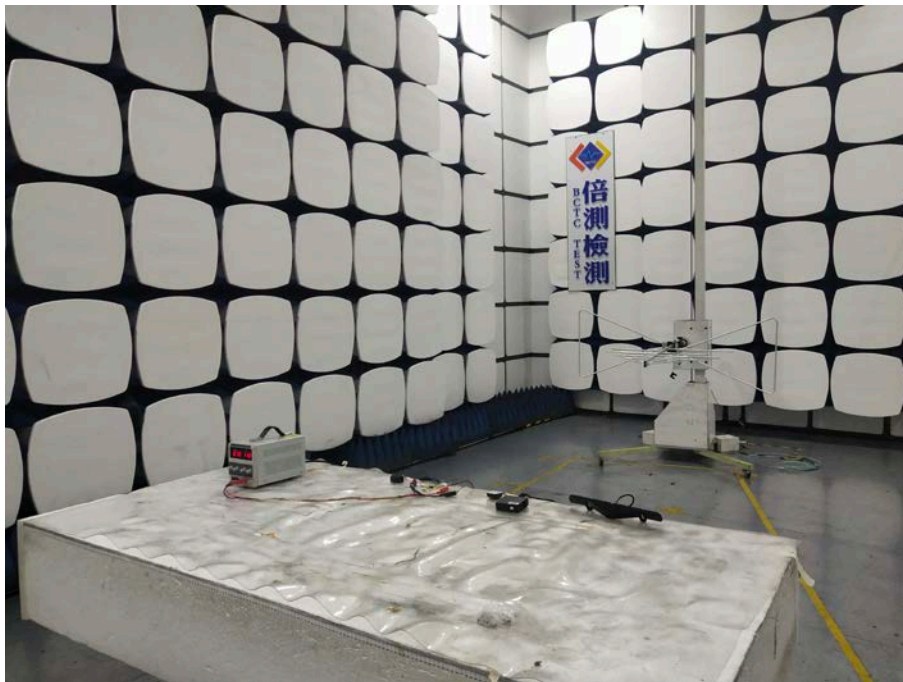

1-18GHz





18-40GHz



7. PHOTOS OF THE EUT

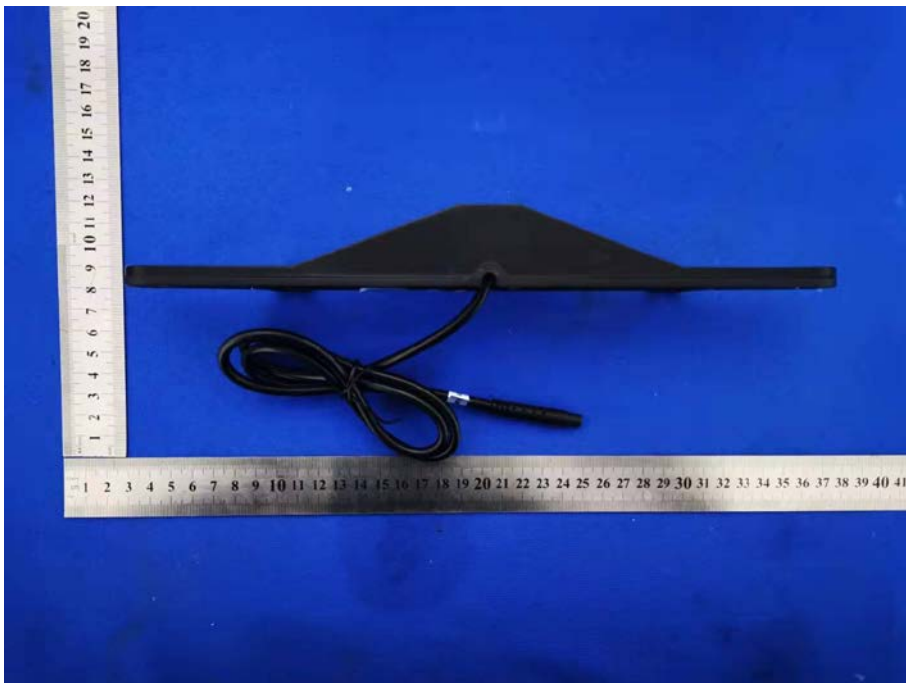



***** END OF REPORT *****