



# FCC TEST REPORT

for

## 47 CFR Part 15 Subpart C and IC RSS-210

**Equipment** : 802.11g USB Wireless Adapter  
**Trade Name** : 2WIRE  
**Model No.** : US-G-AT-02  
**FCC ID** : IXMUSGAT02  
**IC ID** : 4110A-USGAT02  
**Filing Type** : Certification  
**Applicant** : **Universal Scientific Industrial Co., Ltd.**  
141, Lane 351, Taiping Road, Sec. 1, Tsao Tuen, Nan-Tou, Taiwan

- The test result refers exclusively to the test presented test model / sample.
- Without written approval of SPORTON International Inc., the test report shall not be reproduced except in full.
- **Certificate or Test Report must not be used by the applicant to claim the product in this test report endorsement by NVLAP or any agency of U.S. government.**
- The data shown in this test report were carried out on Jul. 17, 2007 at **Sporton International Inc. LAB.**
- Report No.: FR770310, Report Version: Rev. 01

Roy Wu  
Manager

### **SPORTON International Inc.**

6F, No.106, Sec. 1, Hsin Tai Wu Rd., Hsi Chih, Taipei Hsien, Taiwan, R.O.C.



## Table of Contents

History of this test report.....	ii
<b>1. General Description of Equipment under Test.....</b>	<b>1</b>
1.1 Applicant .....	1
1.2 Manufacturer .....	1
1.3 Basic Description of Equipment under Test.....	1
1.4 Feature of Equipment under Test .....	2
<b>2 Test Configuration of Equipment under Test .....</b>	<b>3</b>
2.1 Test Manner .....	3
2.2 Test Mode .....	3
2.3 Connection Diagram of Test System .....	4
2.4 Ancillary Equipment List.....	4
<b>3. RF Utility .....</b>	<b>5</b>
<b>4. General Information of Test.....</b>	<b>6</b>
4.1 Test Voltage .....	6
4.2 Standard for Methods of Measurement.....	6
4.3 Test in Compliance with .....	6
4.4 Frequency Range Investigated .....	6
4.5 Test Distance .....	6
<b>5. Test Data and Test Result.....</b>	<b>7</b>
5.1 List of Measurements and Examinations .....	7
5.2 6dB Bandwidth Measurement .....	8
5.3 Power Spectral Density Measurement.....	22
5.4 Band Edges Measurement.....	37
5.5 Peak Output Power Measurement .....	49
5.6 Conducted Emission .....	51
5.7 Radiated Emission Measurement .....	54
5.8 Antenna Requirements .....	108
<b>6 List of Measuring Equipments Used .....</b>	<b>109</b>
<b>7 Uncertainty Evaluation.....</b>	<b>110</b>
<b>Appendix A. Photographs of EUT External</b>	
<b>Appendix B. Photographs of EUT Internal</b>	
<b>Appendix C. Photographs of Setup</b>	





## **1. General Description of Equipment under Test**

### **1.1 Applicant**

**Universal Scientific Industrial Co., Ltd.**

141, Lane 351, Taiping Road, Sec. 1, Tsao Tuen, Nan-Tou, Taiwan

### **1.2 Manufacturer**

**Universal Scientific Industrial Co., Ltd.**

141, Lane 351, Taiping Road, Sec. 1, Tsao Tuen, Nan-Tou, Taiwan

### **1.3 Basic Description of Equipment under Test**

Equipment	: 802.11g USB Wireless Adapter
Trade Name	: 2WIRE
Model No.	: US-G-AT-02
FCC ID	: IXMUSGAT02
IC ID	: 4110A-USGAT02

**1.4 Feature of Equipment under Test**

Product Feature & Specification	
1. DUT Type	802.11g USB Wireless Adapter
2. Trade Name	2WIRE
3. Model Name	US-G-AT-02
4. FCC ID	IXMUSGAT02
5. IC ID	4110A-USGAT02
6. Tx Frequency	2400 ~ 2483.5 MHz
7. Rx Frequency	2400 ~ 2483.5 MHz
8. Number of Channels	11
9. Carrier Frequency of Each Channel	$2412+(n-1)*5$ MHz; n=1~11
10. Antenna Connector	Antenna 1: N/A Antenna 2: H.U.FL Antenna 3: H.U.FL
11. Antenna Type	Antenna 1: Printed Antenna (Internal) Antenna 2: Printed Antenna (External) Antenna 3: Printed Antenna (External)
12. Antenna Gain	Antenna 1: 2.4 dBi Antenna 2: 2.69 dBi Antenna 3: 2.05 dBi
13. Maximum Output Power	802.11b : 17.61 dBm (for Antenna 1) 17.78 dBm (for Antenna 2 & 3) 802.11g : 20.41 dBm (for Antenna 1) 22.43 dBm (for Antenna 2 & 3)
14. Type of Modulation	DSSS / OFDM
15. DUT Stage	Identical Prototype
16. Application Type	Certification



## 2 Test Configuration of Equipment under Test

### 2.1 Test Manner

- a. The EUT has been associated with peripherals pursuant to ANSI C63.4-2003 and configuration operated in a manner tended to maximize its emission characteristics in a typical application.
- b. The EUT is programmed to transmit signal continuously for all testings.
- c. Frequency range investigated: conduction 150 kHz to 30 MHz, radiation 30 MHz to 25000MHz.

### 2.2 Test Mode

Application		
Radiated Emission	<b>802.11b</b>	<b>802.11g</b>
	Mode 1: Tx_CH01_2412 MHz + Antenna 1	Mode 7: Tx_CH01_2412 MHz + Antenna 1
	Mode 2: Tx_CH06_2437 MHz + Antenna 1	Mode 8: Tx_CH06_2437 MHz + Antenna 1
	Mode 3: Tx_CH11_2462 MHz + Antenna 1	Mode 9: Tx_CH011_2462 MHz + Antenna 1
	Mode 4: Tx_CH01_2412 MHz + Antenna 3	Mode 10: Tx_CH11_2462 MHz + Antenna 2
	Mode 5: Tx_CH06_2437 MHz + Antenna 3	Mode 11: Tx_CH01_2412 MHz + Antenna 3
	Mode 6: Tx_CH11_2462 MHz + Antenna 3	Mode 12: Tx_CH06_2437 MHz + Antenna 3
Conducted Emission	Mode 1: Ping mode + USB Charging+ Antenna 2	

### 2.3 Connection Diagram of Test System

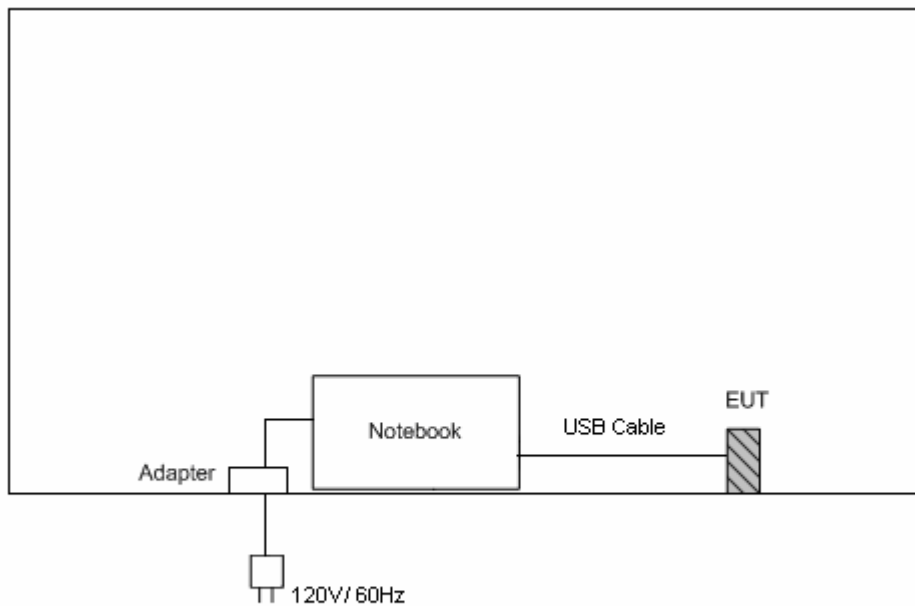

### 2.4 Ancillary Equipment List

Item	Asset	Trade Name	Model Name	FCC ID	Power Cord
1.	Notebook	IBM	2662-GT3	Do C	N/A
2.	USB Cable	N/A	N/A	N/A	N/A



### **3. RF Utility**

The programmed RF Utility is installed in notebook to provide channel selection, power lever, data rate and the application type. RF Utility can send transmitting signal for all testings.





## **4. General Information of Test**

Test Site Location : No. 52, Hwa Ya 1st Rd., Hwa Ya Technology Park,  
Kwei-Shan Hsiang, Tao Yuan Hsien, Taiwan, R.O.C.  
TEL : 886-3-327-3456  
FAX : 886-3-318-0055

Test Site No : CO01-HY, 03CH04-HY

### **4.1 Test Voltage**

AC 120V / 60Hz

### **4.2 Standard for Methods of Measurement**

ANSI C63.4-2003

### **4.3 Test in Compliance with**

47 CFR Part 15 Subpart C and IC RSS-210 Issued 6

### **4.4 Frequency Range Investigated**

- a. Conducted Emission : from 150 KHz to 30 MHz
- b. Radiated Emission : from 30 MHz to 25000 MHz

### **4.5 Test Distance**

The test distance of radiated emission from antenna to EUT is 3 m.



## 5. Test Data and Test Result

### 5.1 List of Measurements and Examinations

FCC Rule	IC Rule	Description of Test	Result
15.207	RSS-Gen 7.2.2	Conducted Emission	Pass
15.247(a)(2)	A8.2 (1)	6dB Bandwidth	Pass
15.247(b)	A8.4 (4)	Maximum Peak Output Power	Pass
15.209(a)	2.6	Radiated Emission	Pass
15.247 (c)	A8.5	100kHz Bandwidth of Frequency Band Edges	Pass
15.247(d)	A8.2 (2)	Power Spectral Density	Pass
15.203 15.247(b)(4)	A8.4 (6)	Antenna Requirement	Pass

## 5.2 6dB Bandwidth Measurement

### 5.2.1 Measuring Instruments :

As described in chapter 6 of this test report.

### 5.2.2 Test Procedure :

1. The transmitter output was connected to the spectrum analyzer directly.
2. Set RBW of spectrum analyzer to 100kHz and VBW to 100kHz.
3. The 6 dB bandwidth is defined as the frequency range where the power is higher than the peak power minus 6dB.

### 5.2.3 Test Setup Layout :

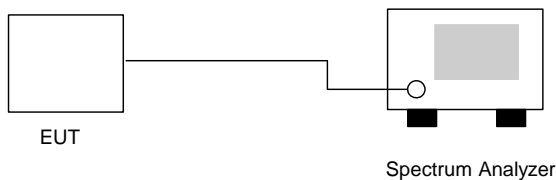

### 5.2.4 Test Result :

- Application Type : 802.11b/g for Antenna 1
- Temperature : 26 ~ 28° C
- Relative Humidity : 53 ~ 55%
- Test Enginner : Tony

#### **802.11b**

Channel	Frequency ( MHz )	6dB Emission bandwidth ( MHz )	Limits ( MHz )	Plot Ref. No.
01	2412	10.08	> 0.5MHz	Mode 1
06	2437	9.76	> 0.5MHz	Mode 2
11	2462	10.04	> 0.5MHz	Mode 3

**802.11g**

Channel	Frequency ( MHz )	6dB Emission bandwidth ( MHz )	Limits ( MHz )	Plot Ref. No.
01	2412	16.40	> 0.5MHz	Mode 7
06	2437	16.40	> 0.5MHz	Mode 8
11	2462	16.40	> 0.5MHz	Mode 9

- Application Type : 802.11b/g for Antenna 2 and 3
- Temperature : 26~28°C
- Relative Humidity : 53~55%
- Test Enginner : Tony

**802.11b**

Channel	Frequency ( MHz )	6dB Emission bandwidth ( MHz )	Limits ( MHz )	Plot Ref. No.
01	2412	9.80	> 0.5MHz	Mode 4
06	2437	9.76	> 0.5MHz	Mode 5
11	2462	9.80	> 0.5MHz	Mode 6

**802.11g**

Channel	Frequency ( MHz )	6dB Emission bandwidth ( MHz )	Limits ( MHz )	Plot Ref. No.
01	2412	16.48	> 0.5MHz	Mode 10
06	2437	16.48	> 0.5MHz	Mode 11
11	2462	16.48	> 0.5MHz	Mode 12



5.2.5 6dB Bandwidth

Mode 1

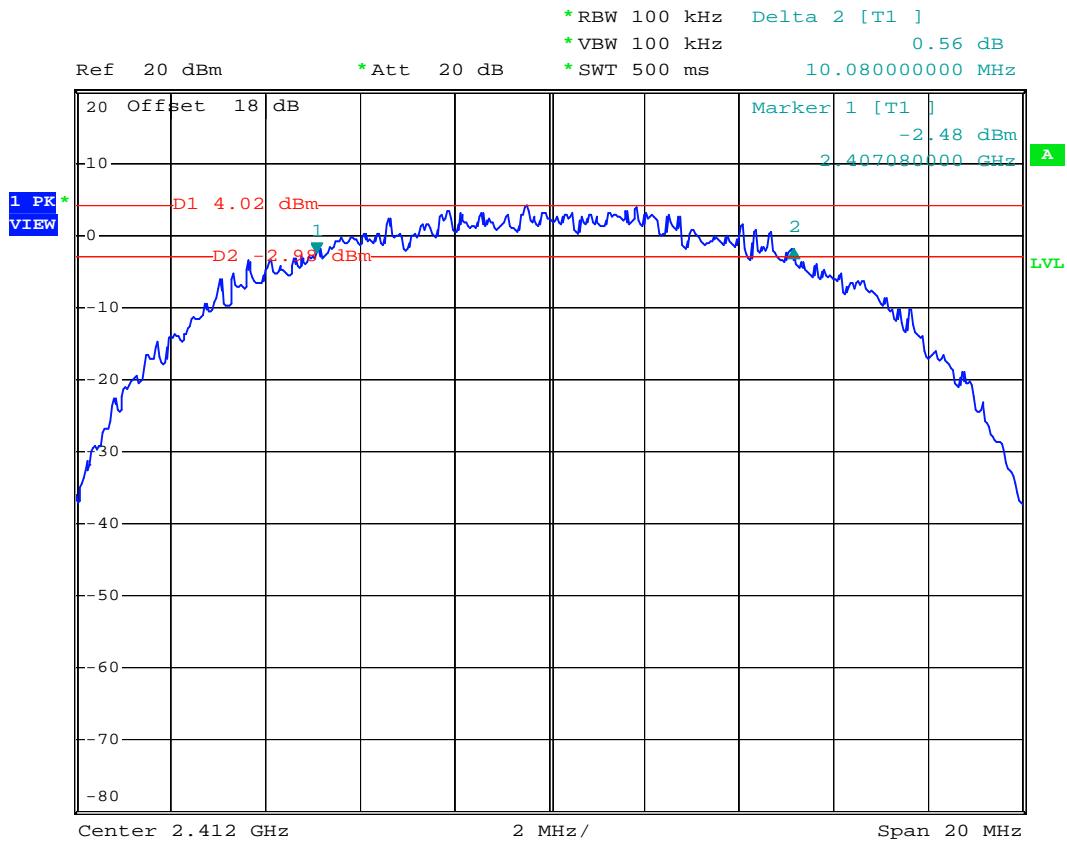

Date: 17.JUL.2007 20:50:08



Mode 2

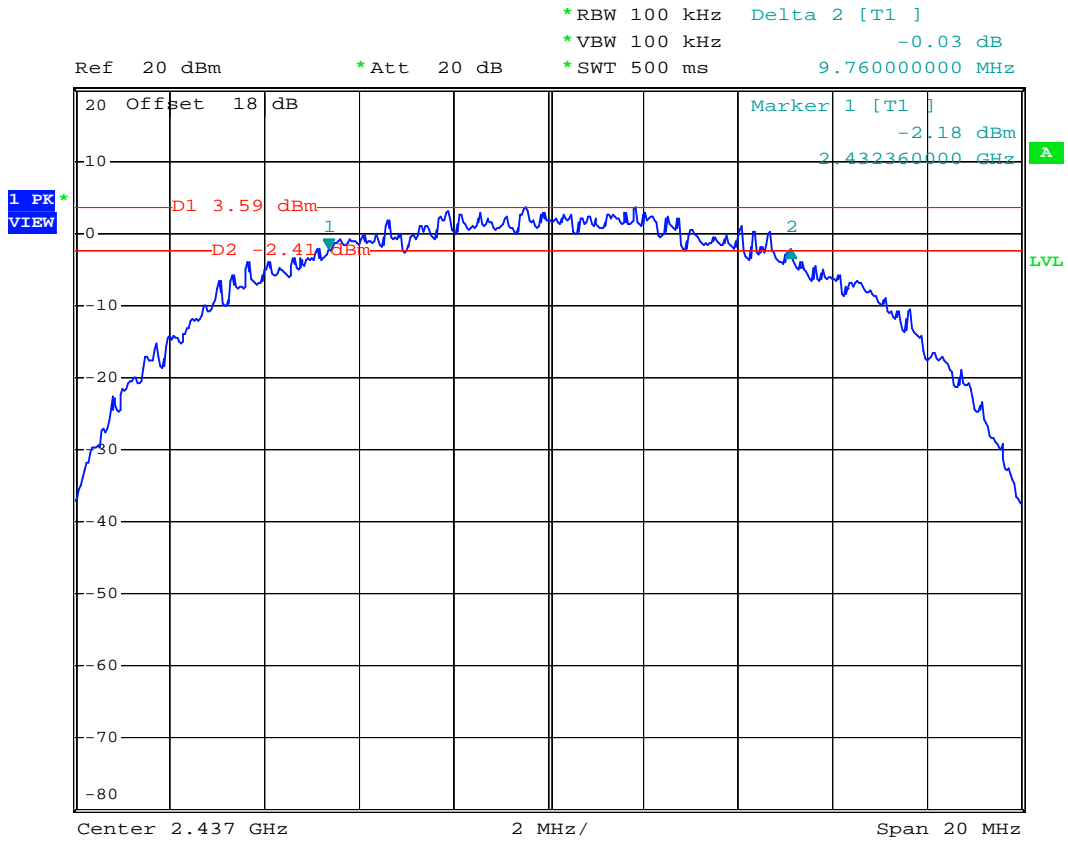

Date: 17.JUL.2007 20:50:57



Mode 3

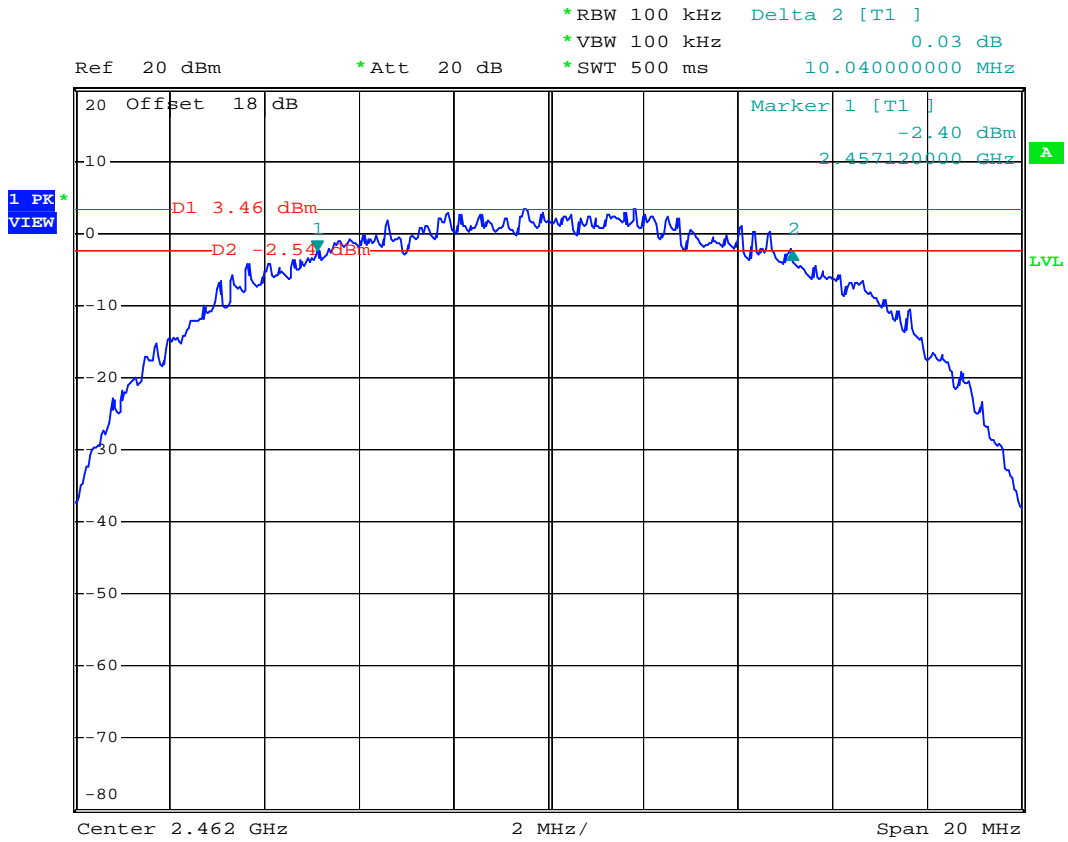

Date: 17.JUL.2007 20:51:40



Mode 4

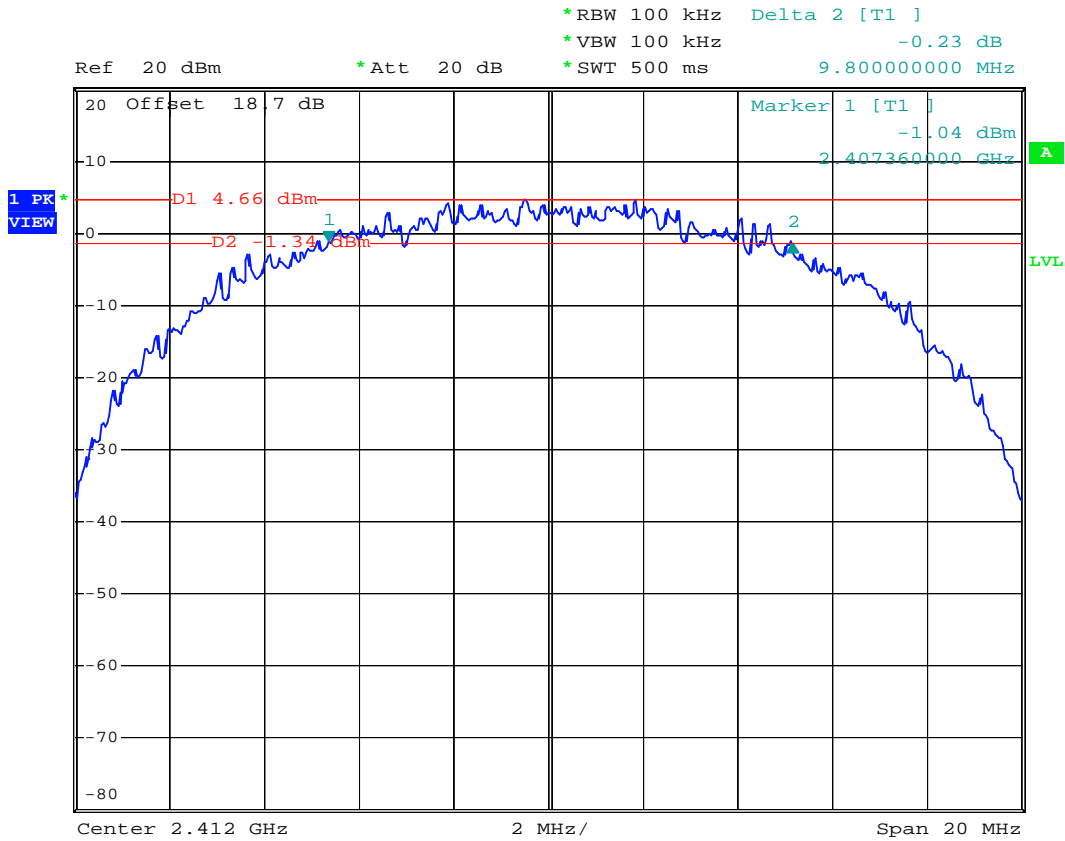

Date: 17.JUL.2007 16:51:03





Mode 5

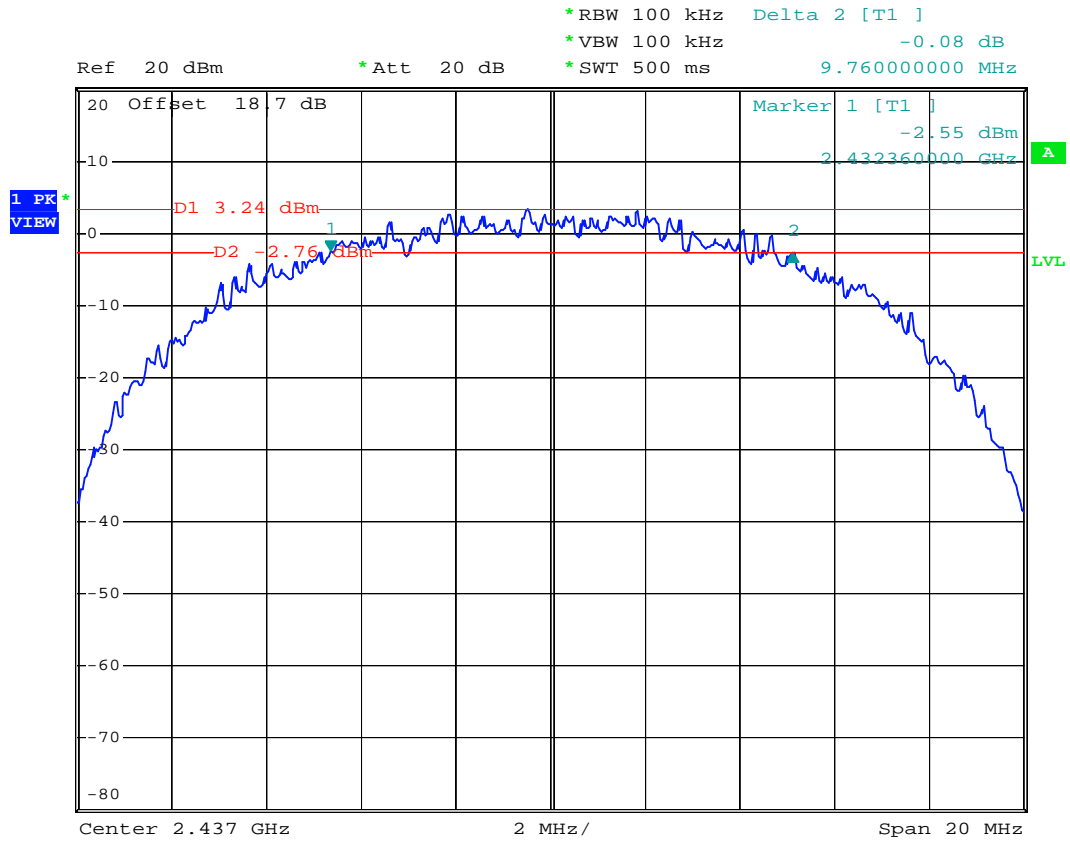

Date: 17.JUL.2007 16:53:10



Mode 6

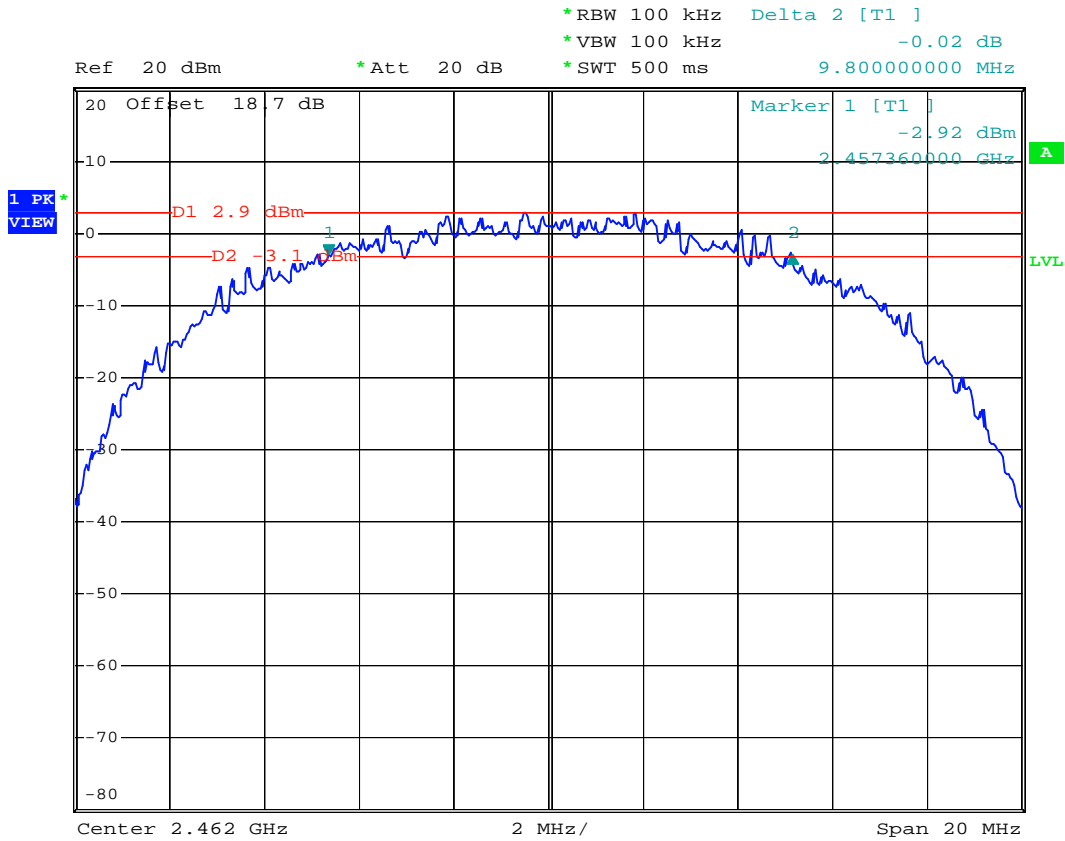

Date: 17.JUL.2007 16:55:34



Mode 7

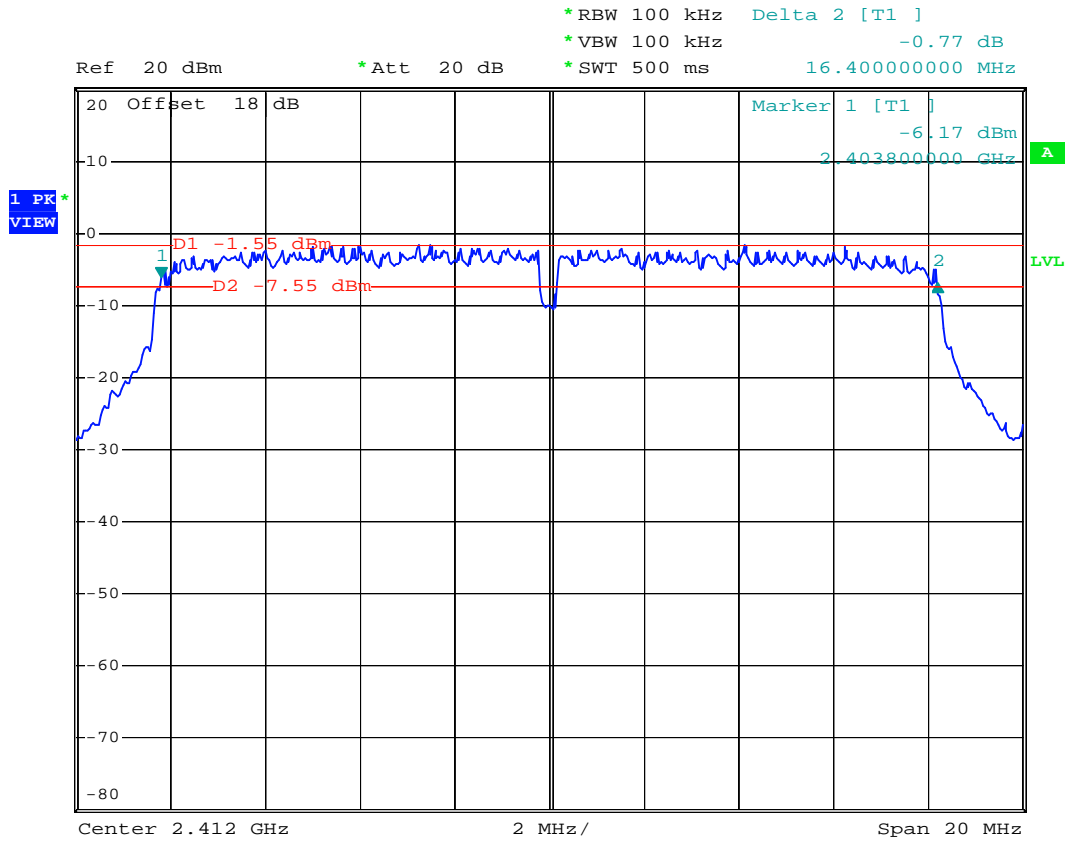

Date: 17.JUL.2007 21:35:54



Mode 8

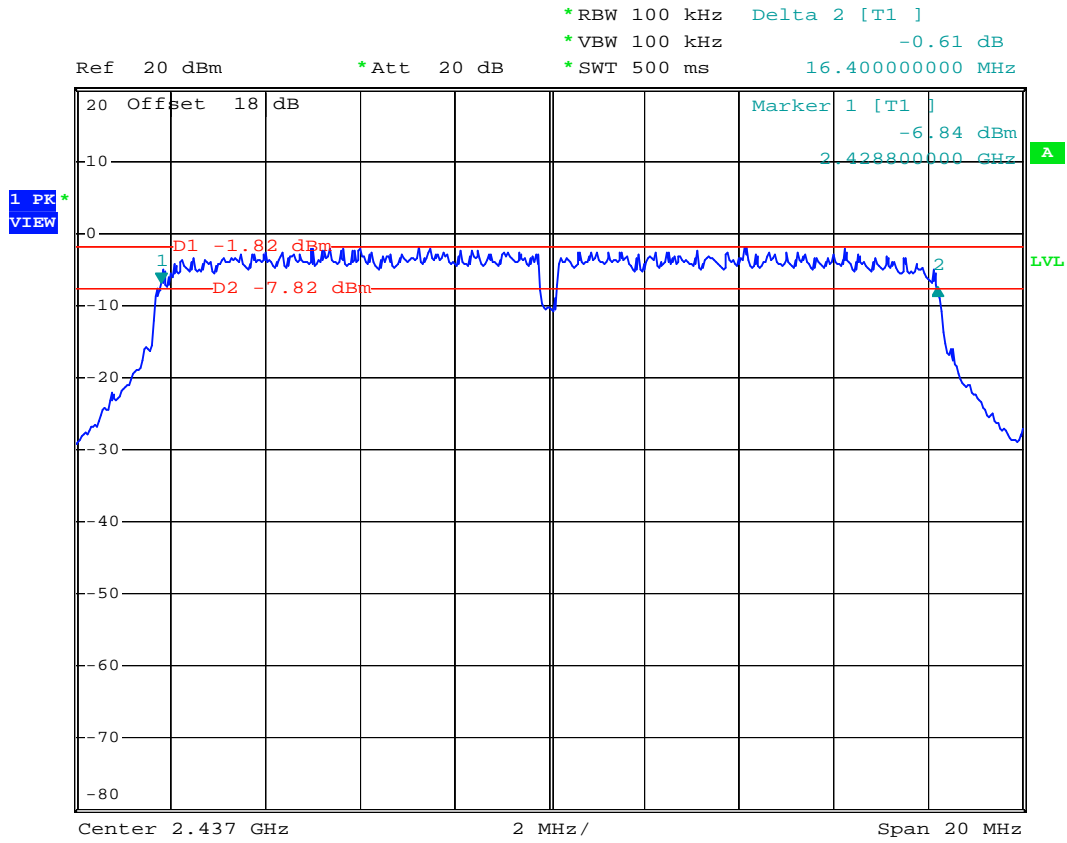

Date: 17.JUL.2007 21:36:34



Mode 9

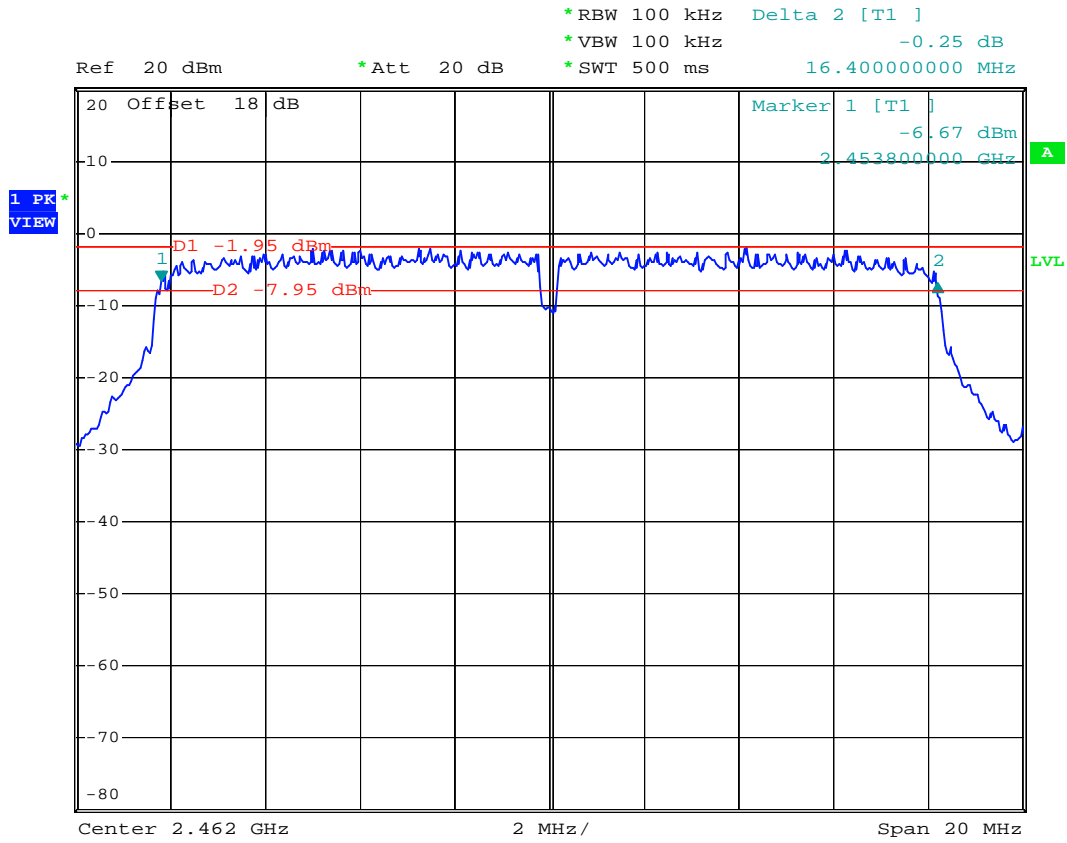

Date: 17.JUL.2007 21:37:48



Mode 10

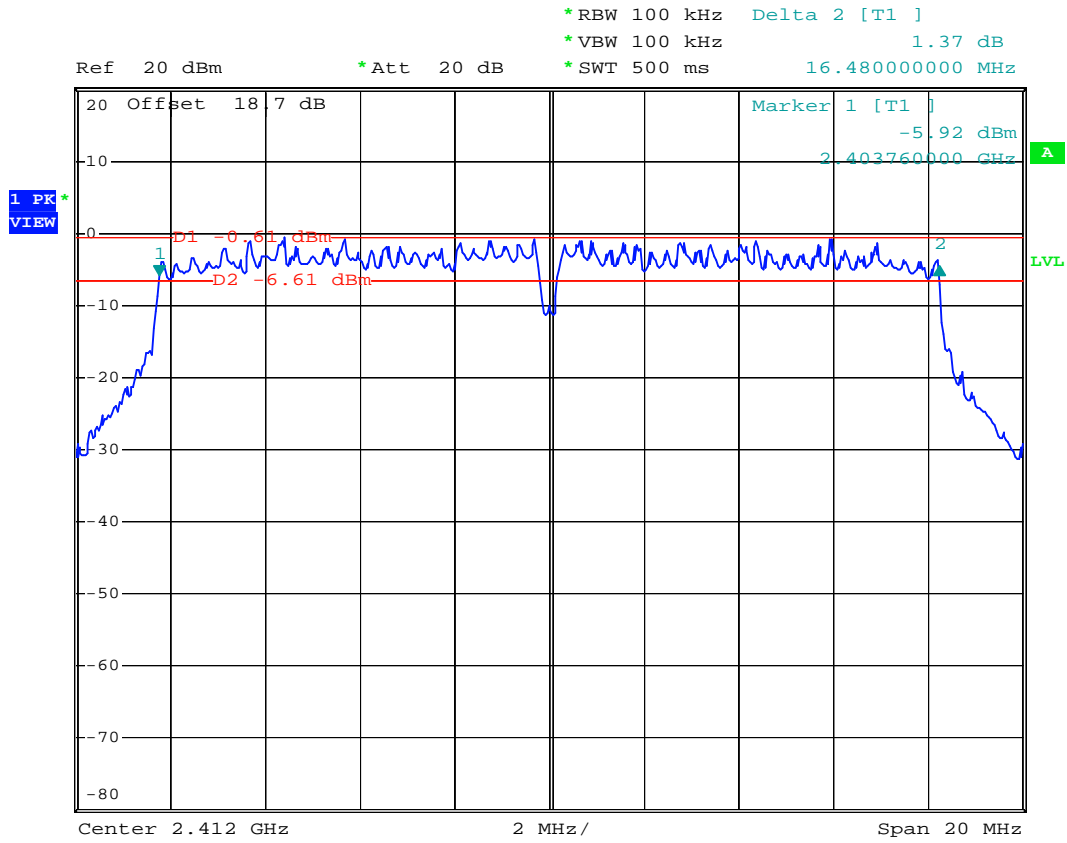

Date: 17.JUL.2007 18:04:30



Mode 11

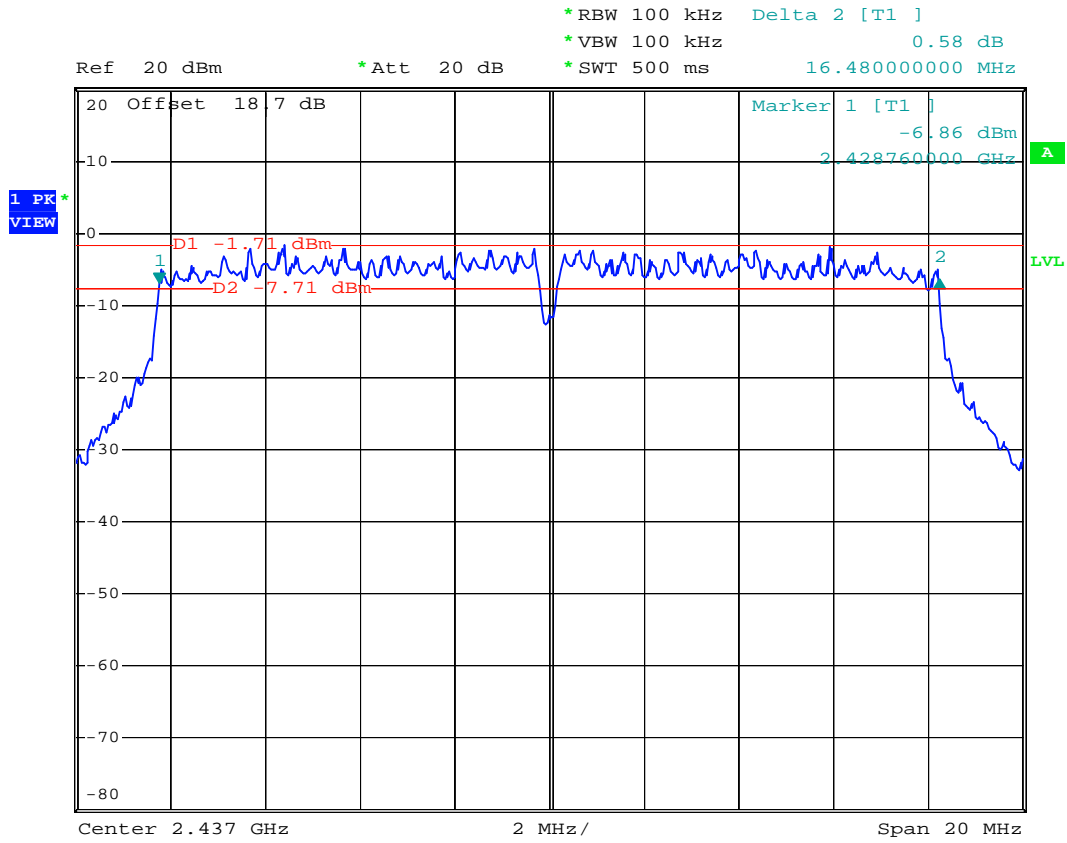

Date: 17.JUL.2007 18:06:00



Mode 12

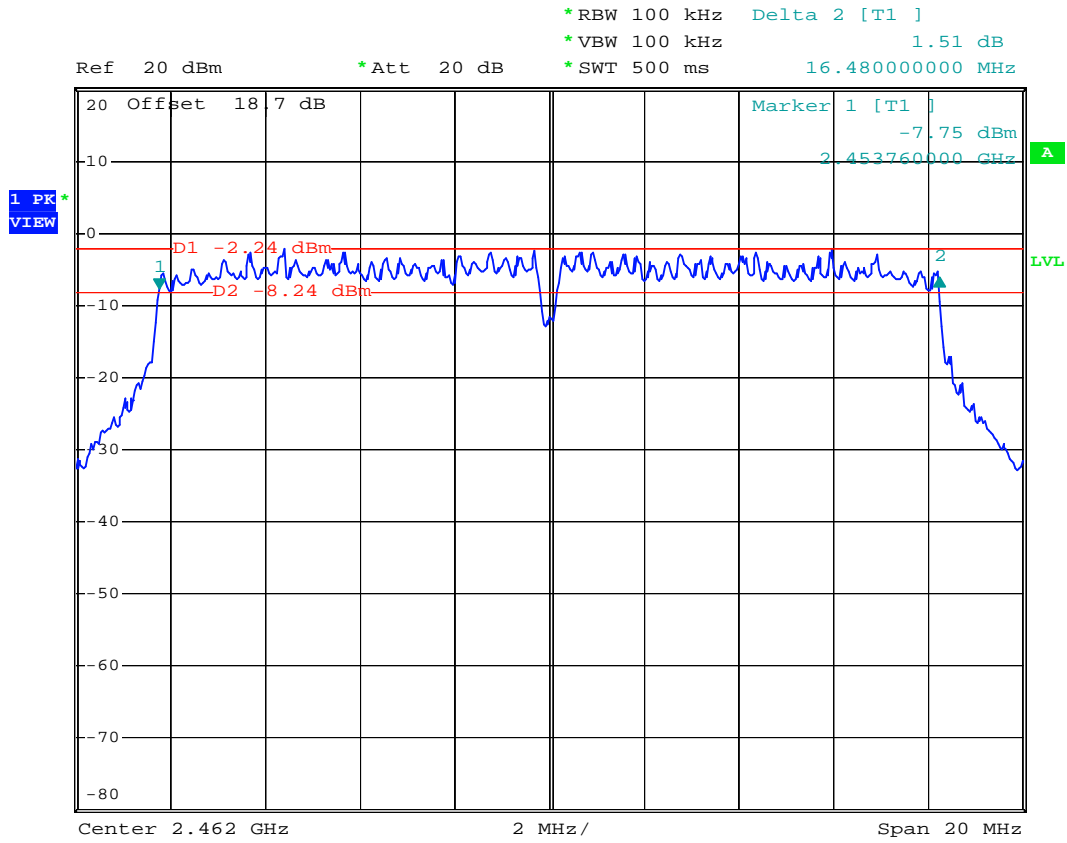

Date: 17.JUL.2007 18:06:47



### 5.3 Power Spectral Density Measurement

#### 5.3.1 Measuring Instruments :

As described in chapter 6 of this test report.

#### 5.3.2 Test Procedure :

1. The transmitter output was connected to spectrum analyzer directly.
2. The spectrum analyzer's resolution bandwidth was set at 3kHz RBW and 30kHz VBW as that of the fundamental frequency. Set the sweep time=span/3kHz.
3. The power spectral density was measured and recorded.
4. The sweep time is allowed to be longer than span/3kHz for a full response of the mixer in the spectrum analyzer.

#### 5.3.3 Test Setup Layout :

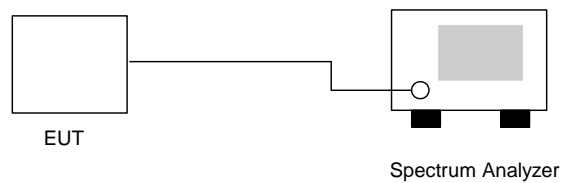



5.3.4 Test Result :

- Application Type : 802.11b/g for Antenna 1
- Temperature : 26~28°C
- Relative Humidity : 52~55%
- Test Enginner : Tony

**802.11b**

Channel	Frequency (MHz)	Power Spectral Density (dBm)	Limits (dBm )	Plot Ref. No.
01	2412	-6.98	8	Mode 1
06	2437	-8.61	8	Mode 2
11	2462	-8.70	8	Mode 3

**802.11g**

Channel	Frequency (MHz)	Power Spectral Density (dBm)	Limits (dBm )	Plot Ref. No.
01	2412	-16.64	8	Mode 7
06	2437	-15.73	8	Mode 8
11	2462	-17.18	8	Mode 9

- Application Type : 802.11b/g for Antenna 2 and 3
- Temperature : 26~28°C
- Relative Humidity : 52~55%
- Test Enginner : Tony

**802.11b**

Channel	Frequency (MHz)	Power Spectral Density (dBm)	Limits (dBm )	Plot Ref. No.
01	2412	-7.59	8	Mode 4
06	2437	-8.57	8	Mode 5
11	2462	-9.18	8	Mode 6



**802.11g**

---

---

Channel	Frequency (MHz)	Power Spectral Density (dBm)	Limits (dBm )	Plot Ref. No.
01	2412	-14.94	8	Mode 10
06	2437	-16.03	8	Mode 11
11	2462	-16.65	8	Mode 12

---

---



5.3.5 Power Spectral Density

Mode 1

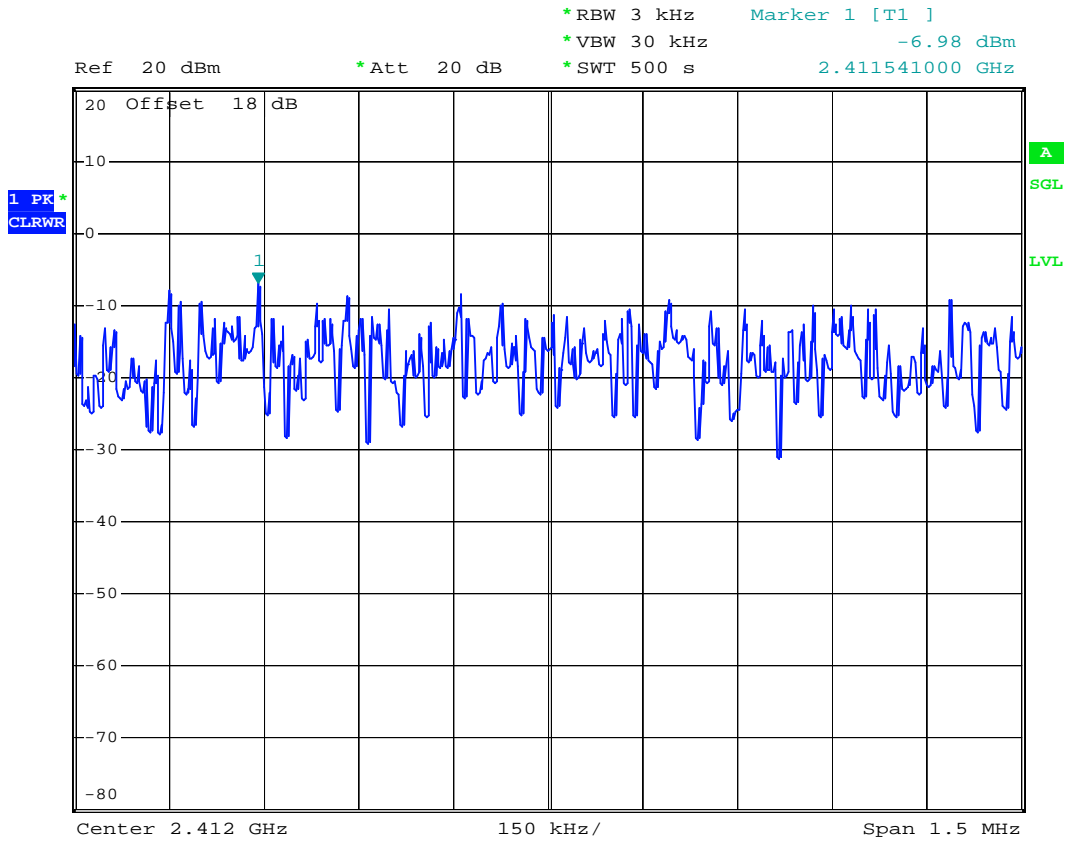

Date: 17.JUL.2007 21:06:46



Mode 2

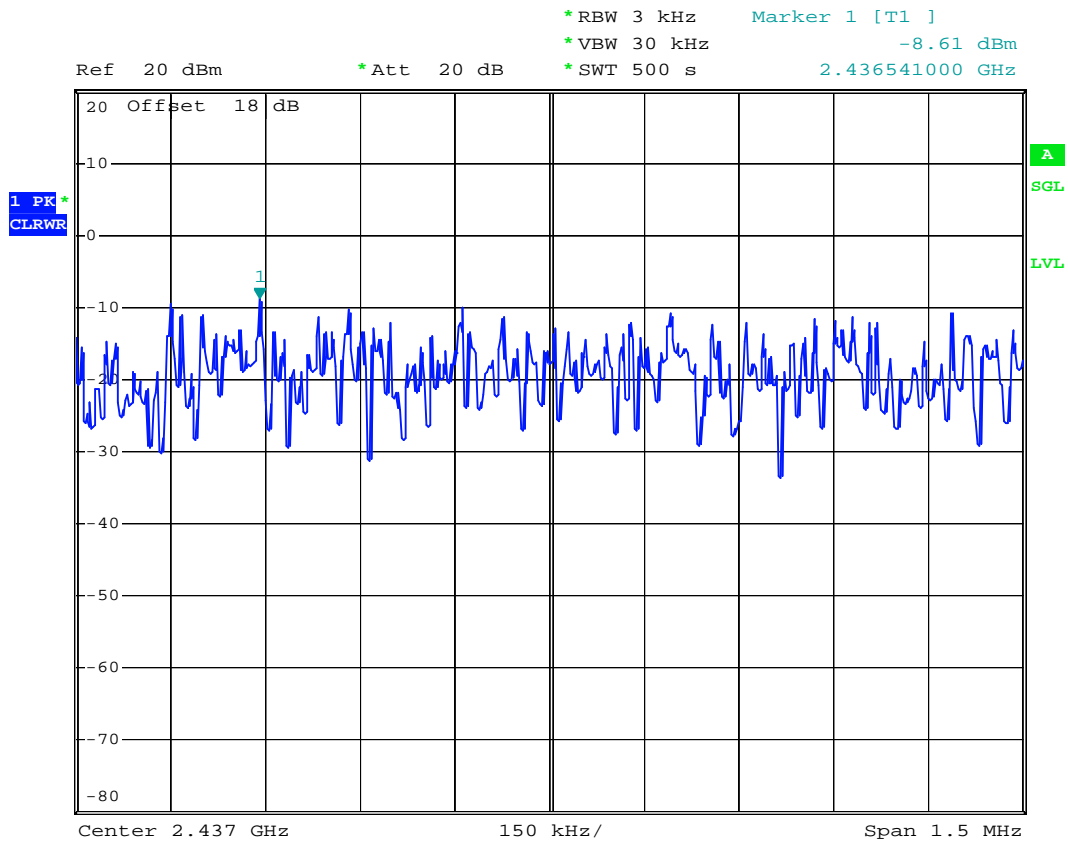

Date: 17.JUL.2007 21:16:05



Mode 3

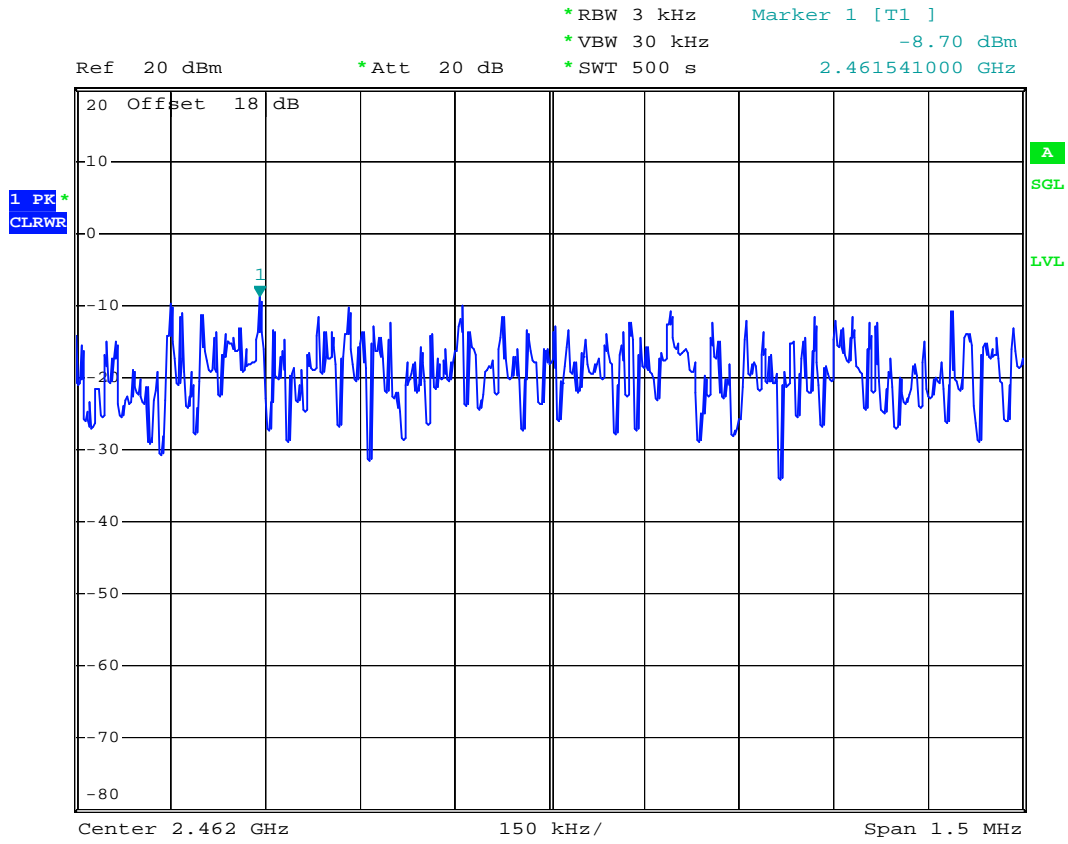

Date: 17.JUL.2007 21:25:11



Mode 4

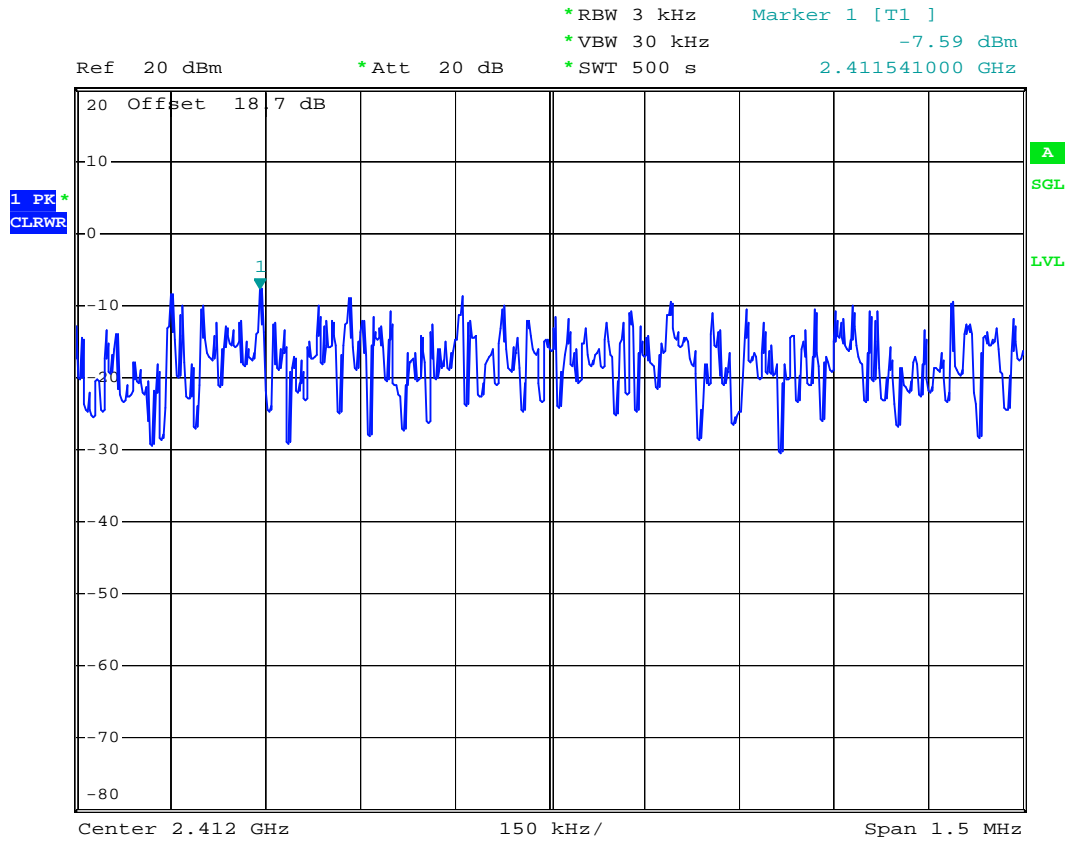

Date: 17.JUL.2007 17:10:46



Mode 5

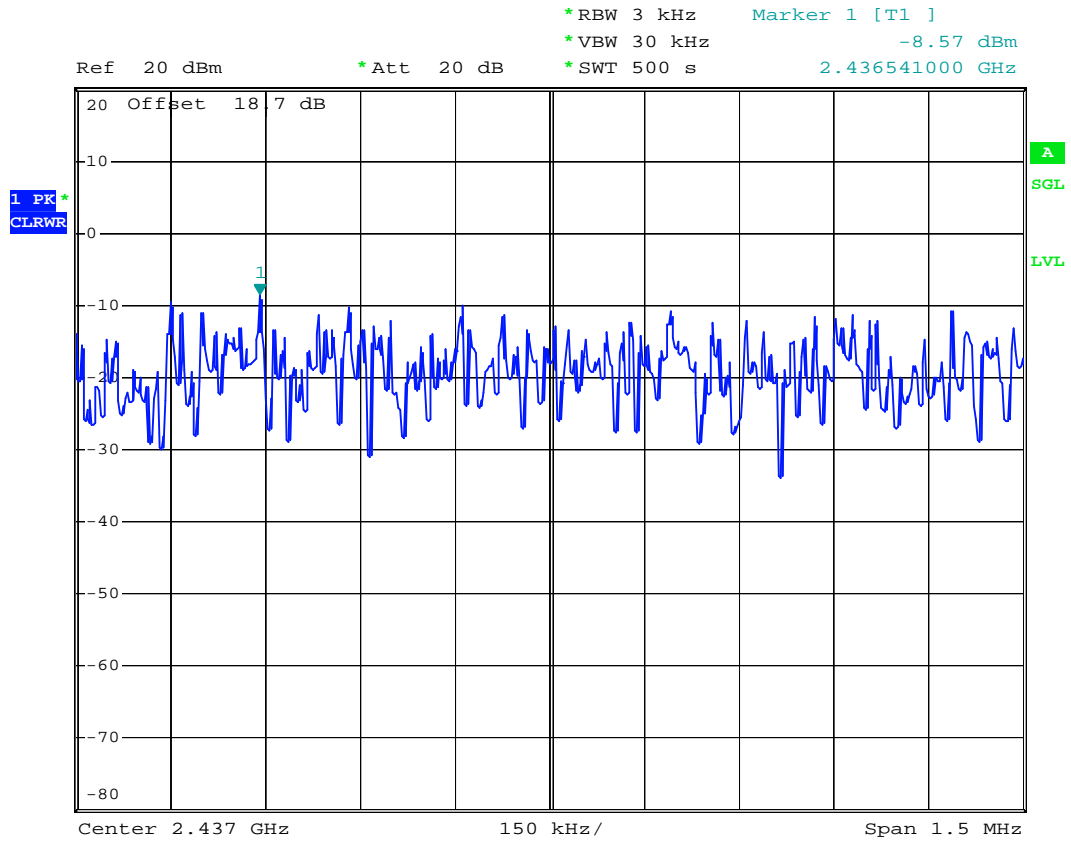

Date: 17.JUL.2007 17:42:13





Mode 6

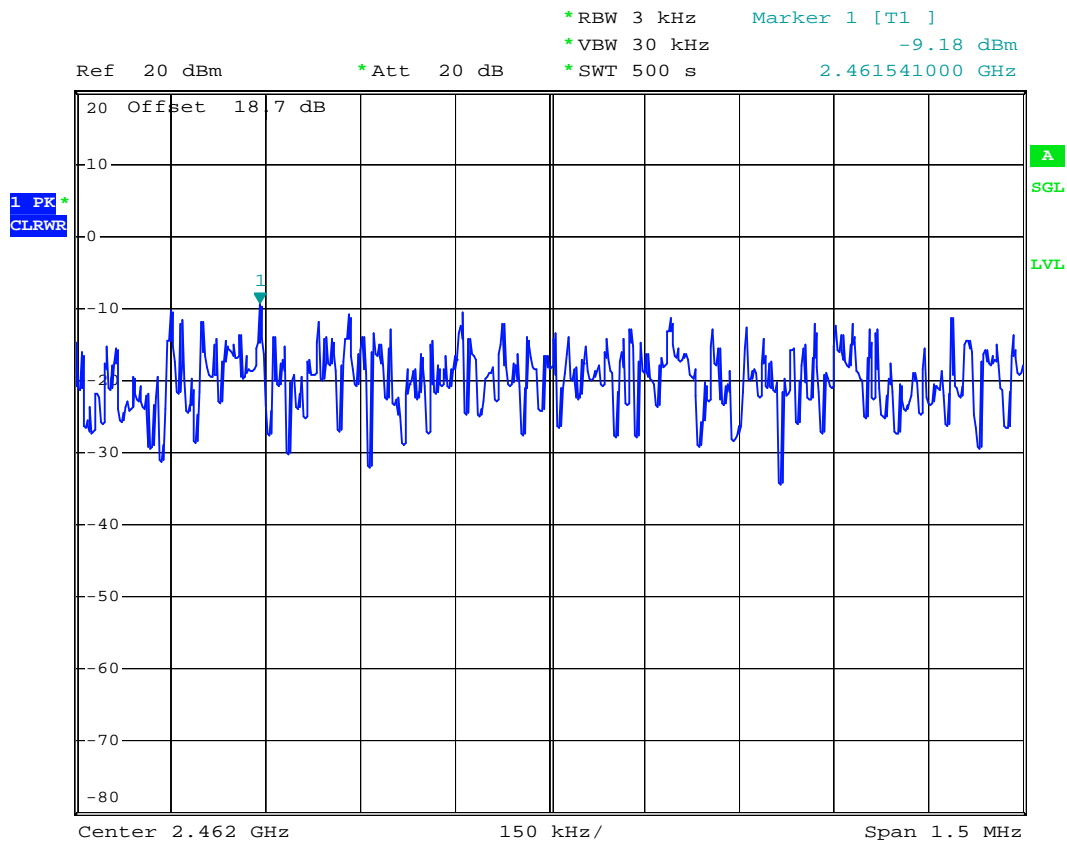

Date: 17.JUL.2007 17:30:57



Mode 7

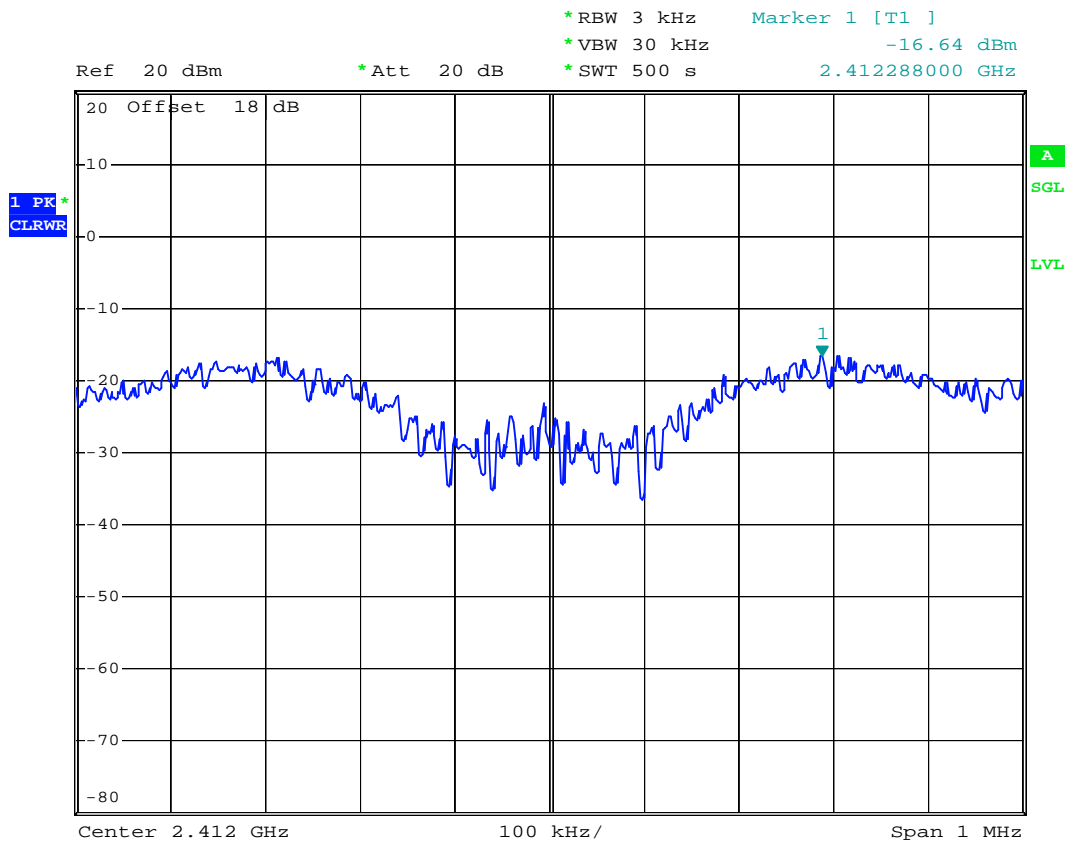

Date: 17.JUL.2007 21:51:14



Mode 8

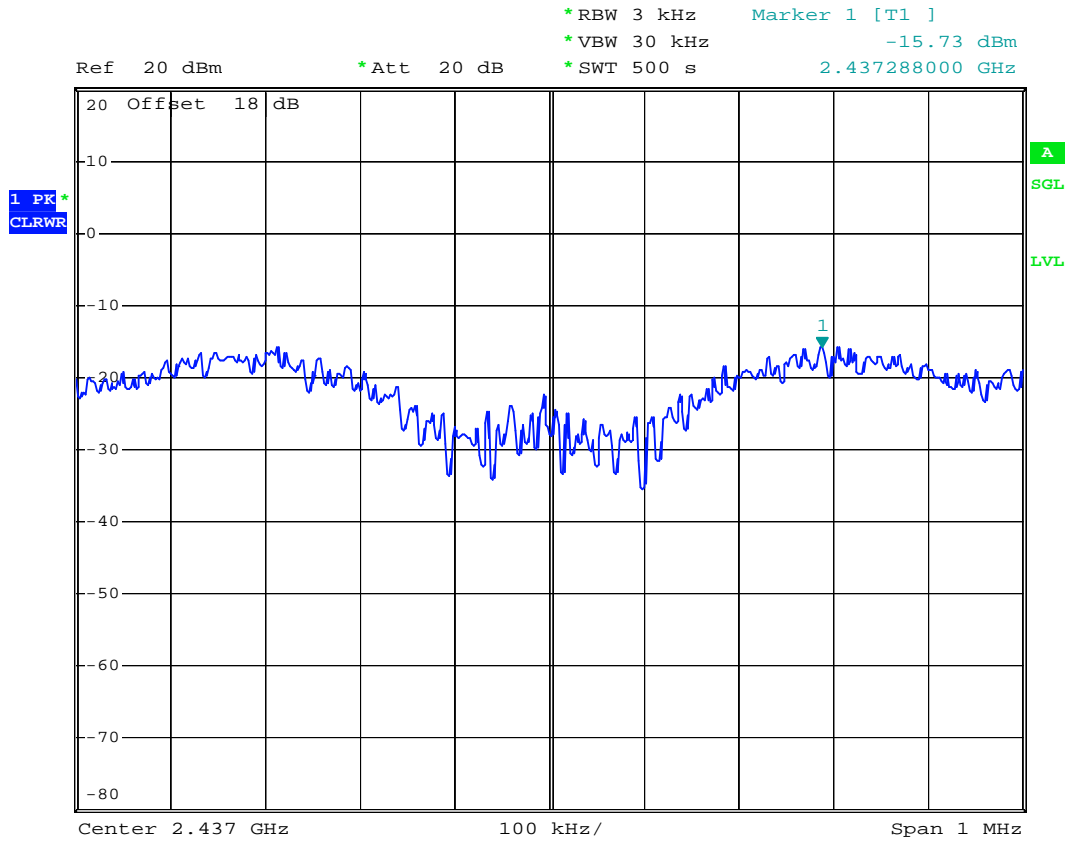

Date: 17.JUL.2007 22:05:17



Mode 9

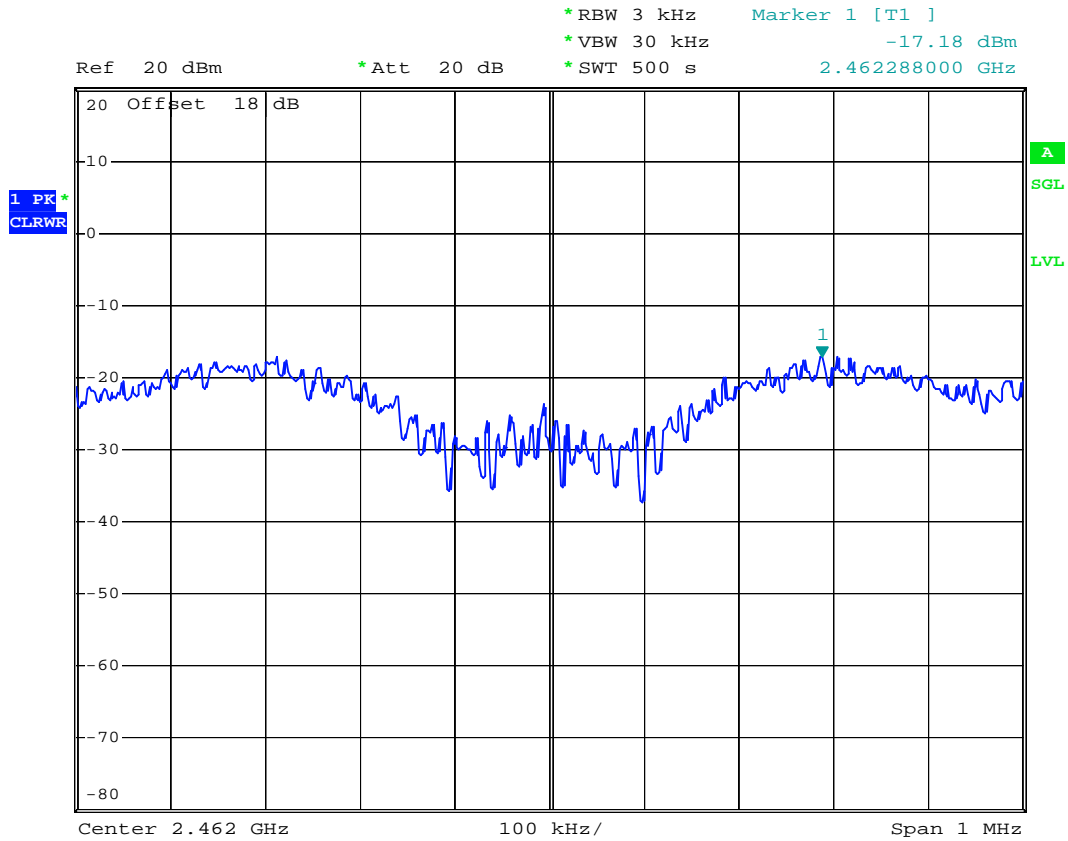

Date: 17.JUL.2007 22:14:40



Mode 10

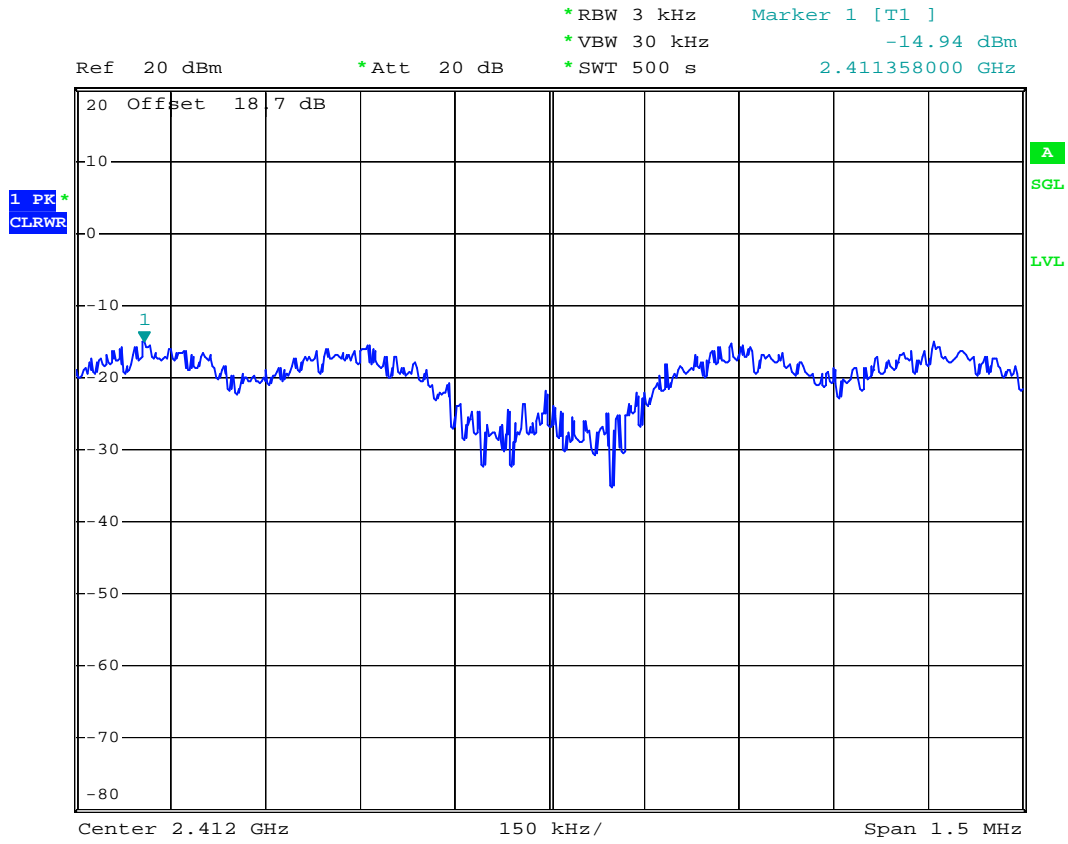

Date: 17.JUL.2007 18:28:02



Mode 11

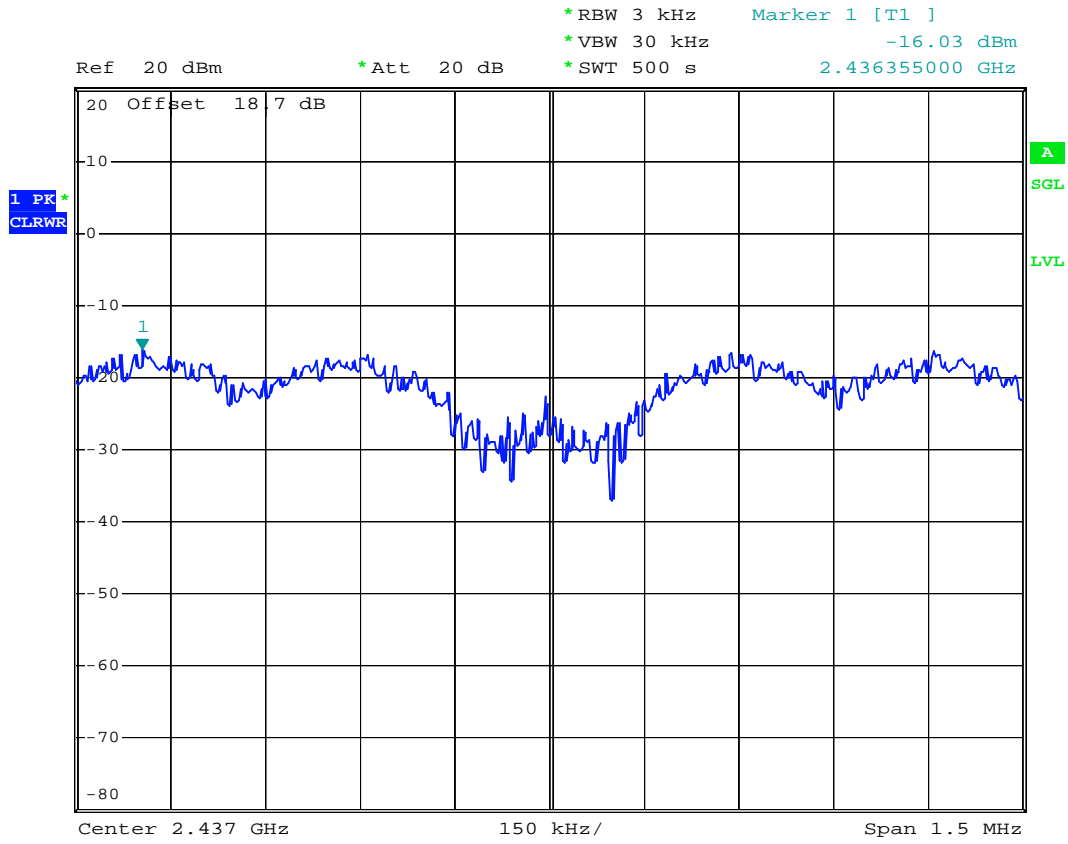

Date: 17.JUL.2007 18:37:06



Mode 12

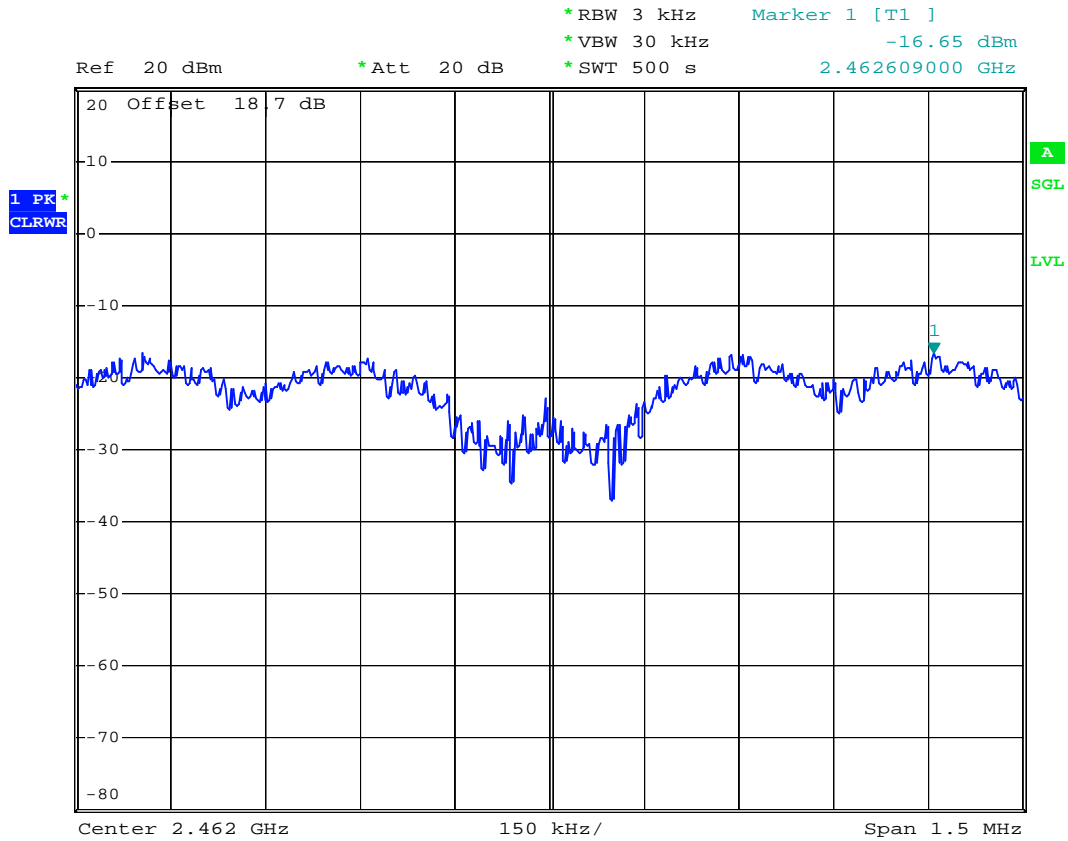

Date: 17.JUL.2007 18:49:20



### 5.4 Band Edges Measurement

#### 5.4.1 Measuring Instruments :

As described in chapter 6 of this test report.

#### 5.4.2 Test Procedure :

1. The transmitter output was connected to the spectrum analyzer via a low lose cable.
2. Set both RBW and VBW of spectrum analyzer to 100kHz with suitable frequency span including 100 kHz bandwidth from band edge.
3. The band edges was measured and recorded.

#### 5.4.3 Test Result :

- Application Type : WLAN 802.11b/g
- Temperature : 26~28°C
- Relative Humidity : 52~55%
- Test Enginner : Tony
  
- Test Result in WLAN lower band (Channel 1) : PASS
- Test Result in WLAN higher band (Channel 11) : PASS

#### 5.4.4 Note on Band Edge Emission :

➤WLAN 802.11b for Antenna 1

##### CH01 (Horizontal)

Frequency ( MHz )	Level ( dBuV/m )	Over Limit ( dB )	Limit Line ( dBuV/m )	Read Level ( dBuV )	Antenna Factor ( dB/m )	Cable Loss ( dB )	Preamp Factor ( dB )	Ant Pos ( cm )	Table Pos ( deg )	Remark
2368.140	46.91	-27.09	74.00	46.37	30.59	3.74	33.78	100	0	Peak
2368.140	34.93	-19.07	54.00	34.34	30.65	3.71	33.78	100	100	Average

##### CH01 (Vertical)

Frequency ( MHz )	Level ( dBuV/m )	Over Limit ( dB )	Limit Line ( dBuV/m )	Read Level ( dBuV )	Antenna Factor ( dB/m )	Cable Loss ( dB )	Preamp Factor ( dB )	Ant Pos ( cm )	Table Pos ( deg )	Remark
2388.090	50.04	-23.96	74.00	49.50	30.59	3.74	33.78	100	0	Peak
2388.090	37.49	-16.51	54.00	36.94	30.59	3.74	33.78	100	357	Average





CH11 (Horizontal)

Frequency ( MHz )	Level ( dBuV/m )	Over Limit ( dB )	Limit Line ( dBuV/m )	Read Level ( dBuV )	Antenna Factor ( dB/m )	Cable Loss ( dB )	Preamp Factor ( dB )	Ant Pos ( cm )	Table Pos ( deg )	Remark
2487.460	32.58	-21.42	54.00	32.11	30.43	3.84	33.80	100	272	Average
2487.460	45.81	-28.19	74.00	45.34	30.43	3.84	33.80	100	0	Peak

CH11 (Vertical)

Frequency ( MHz )	Level ( dBuV/m )	Over Limit ( dB )	Limit Line ( dBuV/m )	Read Level ( dBuV )	Antenna Factor ( dB/m )	Cable Loss ( dB )	Preamp Factor ( dB )	Ant Pos ( cm )	Table Pos ( deg )	Remark
2488.220	34.35	-19.66	54.00	33.91	30.40	3.84	33.80	100	60	Average
2488.220	47.34	-26.66	74.00	46.87	30.43	3.84	33.80	100	0	Peak

➤WLAN 802.11b for Antenna 2 and 3

CH01 (Horizontal)

Frequency ( MHz )	Level ( dBuV/m )	Over Limit ( dB )	Limit Line ( dBuV/m )	Read Level ( dBuV )	Antenna Factor ( dB/m )	Cable Loss ( dB )	Preamp Factor ( dB )	Ant Pos ( cm )	Table Pos ( deg )	Remark
2390.000	51.53	-22.47	74.00	50.99	30.59	3.74	33.78	100	0	Peak
2390.000	40.92	-13.08	54.00	40.38	30.59	3.74	33.78	100	130	Average

CH01 (Vertical)

Frequency ( MHz )	Level ( dBuV/m )	Over Limit ( dB )	Limit Line ( dBuV/m )	Read Level ( dBuV )	Antenna Factor ( dB/m )	Cable Loss ( dB )	Preamp Factor ( dB )	Ant Pos ( cm )	Table Pos ( deg )	Remark
2390.000	50.45	-23.55	74.00	49.91	30.59	3.74	33.78	100	0	Peak
2390.000	40.33	-13.67	54.00	39.79	30.59	3.74	33.78	100	60	Average

CH11 (Horizontal)

Frequency ( MHz )	Level ( dBuV/m )	Over Limit ( dB )	Limit Line ( dBuV/m )	Read Level ( dBuV )	Antenna Factor ( dB/m )	Cable Loss ( dB )	Preamp Factor ( dB )	Ant Pos ( cm )	Table Pos ( deg )	Remark
2483.500	48.93	-25.07	74.00	48.46	30.43	3.84	33.80	100	0	Peak
2483.500	35.36	-18.64	54.00	34.89	30.43	3.84	33.80	100	357	Average



CH11 (Vertical)

Frequency ( MHz )	Level ( dBuV/m )	Over Limit ( dB )	Limit Line ( dBuV/m )	Read Level ( dBuV )	Antenna Factor ( dB/m )	Cable Loss ( dB )	Preamp Factor ( dB )	Ant Pos ( cm )	Table Pos ( deg )	Remark
2483.500	37.74	-16.26	54.00	37.27	30.43	3.84	33.80	100	268	Average
2483.500	47.82	-26.18	74.00	47.35	30.43	3.84	33.80	100	0	Peak

➤WLAN 802.11g for Antenna 1

CH01 (Horizontal)

Frequency ( MHz )	Level ( dBuV/m )	Over Limit ( dB )	Limit Line ( dBuV/m )	Read Level ( dBuV )	Antenna Factor ( dB/m )	Cable Loss ( dB )	Preamp Factor ( dB )	Ant Pos ( cm )	Table Pos ( deg )	Remark
2390.000	63.57	-10.43	74.00	63.03	30.59	3.74	33.78	100	0	Peak
2390.000	38.85	-15.15	54.00	38.31	30.59	3.74	33.78	100	273	Average

CH01 (Vertical)

Frequency ( MHz )	Level ( dBuV/m )	Over Limit ( dB )	Limit Line ( dBuV/m )	Read Level ( dBuV )	Antenna Factor ( dB/m )	Cable Loss ( dB )	Preamp Factor ( dB )	Ant Pos ( cm )	Table Pos ( deg )	Remark
2390.000	66.54	-7.46	74.00	66.00	30.59	3.74	33.78	100	0	Peak
2390.000	41.81	-12.19	54.00	41.27	30.59	3.74	33.78	100	357	Average

CH11 (Horizontal)

Frequency ( MHz )	Level ( dBuV/m )	Over Limit ( dB )	Limit Line ( dBuV/m )	Read Level ( dBuV )	Antenna Factor ( dB/m )	Cable Loss ( dB )	Preamp Factor ( dB )	Ant Pos ( cm )	Table Pos ( deg )	Remark
2483.500	63.36	-10.64	74.00	62.89	30.43	3.84	33.80	100	0	Peak
2483.500	40.82	-13.18	54.00	40.35	30.43	3.84	33.80	100	0	Average



CH11 (Vertical)

Frequency ( MHz )	Level ( dBuV/m )	Over Limit ( dB )	Limit Line ( dBuV/m )	Read Level ( dBuV )	Antenna Factor ( dB/m )	Cable Loss ( dB )	Preamp Factor ( dB )	Ant Pos ( cm )	Table Pos ( deg )	Remark
2483.500	34.42	-19.58	54.00	33.95	30.43	3.84	33.80	100	135	Average
2483.500	57.94	-16.06	74.00	57.47	30.43	3.84	33.80	100	0	Peak

➤WLAN 802.11g for Antenna 2 and 3

CH01 (Horizontal)

Frequency ( MHz )	Level ( dBuV/m )	Over Limit ( dB )	Limit Line ( dBuV/m )	Read Level ( dBuV )	Antenna Factor ( dB/m )	Cable Loss ( dB )	Preamp Factor ( dB )	Ant Pos ( cm )	Table Pos ( deg )	Remark
2390.000	49.87	-4.13	54.00	49.33	30.59	3.74	33.78	100	130	Average
2390.000	69.77	-4.23	74.00	69.23	30.59	3.74	33.78	100	0	Peak

CH01 (Vertical)

Frequency ( MHz )	Level ( dBuV/m )	Over Limit ( dB )	Limit Line ( dBuV/m )	Read Level ( dBuV )	Antenna Factor ( dB/m )	Cable Loss ( dB )	Preamp Factor ( dB )	Ant Pos ( cm )	Table Pos ( deg )	Remark
2390.000	68.24	-5.76	74.00	67.70	30.59	3.74	33.78	100	0	Peak
2390.000	47.03	-6.97	54.00	46.49	30.59	3.74	33.78	100	60	Average

CH11 (Horizontal)

Frequency ( MHz )	Level ( dBuV/m )	Over Limit ( dB )	Limit Line ( dBuV/m )	Read Level ( dBuV )	Antenna Factor ( dB/m )	Cable Loss ( dB )	Preamp Factor ( dB )	Ant Pos ( cm )	Table Pos ( deg )	Remark
2483.500	48.11	-5.89	54.00	47.64	30.43	3.84	33.80	100	270	Average
2483.500	69.57	-4.43	74.00	69.10	30.43	3.84	33.80	100	0	Peak

CH11 (Vertical)

Frequency ( MHz )	Level ( dBuV/m )	Over Limit ( dB )	Limit Line ( dBuV/m )	Read Level ( dBuV )	Antenna Factor ( dB/m )	Cable Loss ( dB )	Preamp Factor ( dB )	Ant Pos ( cm )	Table Pos ( deg )	Remark
2483.500	68.65	-5.34	74.00	68.19	30.43	3.84	33.80	100	0	Peak
2483.500	48.47	-5.53	54.00	48.00	30.43	3.84	33.80	100	355	Average



5.4.4 20dB Band Edge

WLAN 802.11b for Antenna 1

CH01

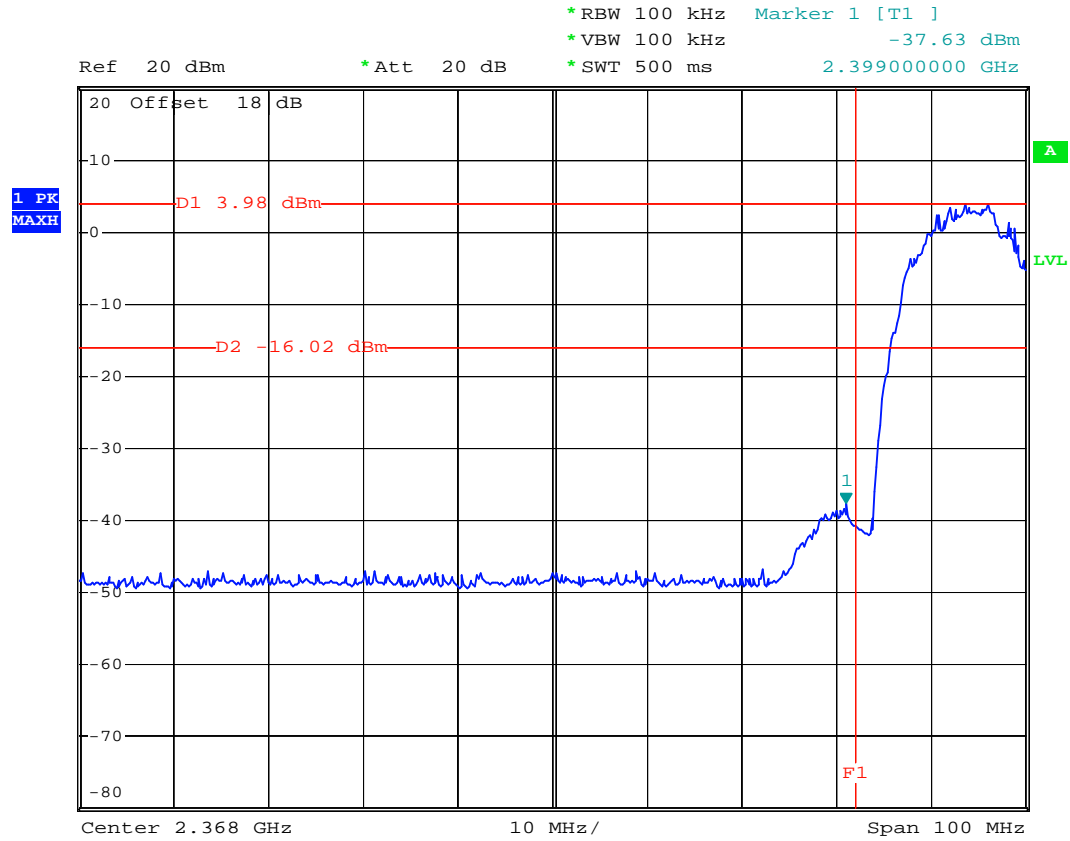

Date: 17.JUL.2007 20:52:45



WLAN 802.11b for Antenna 1  
CH11

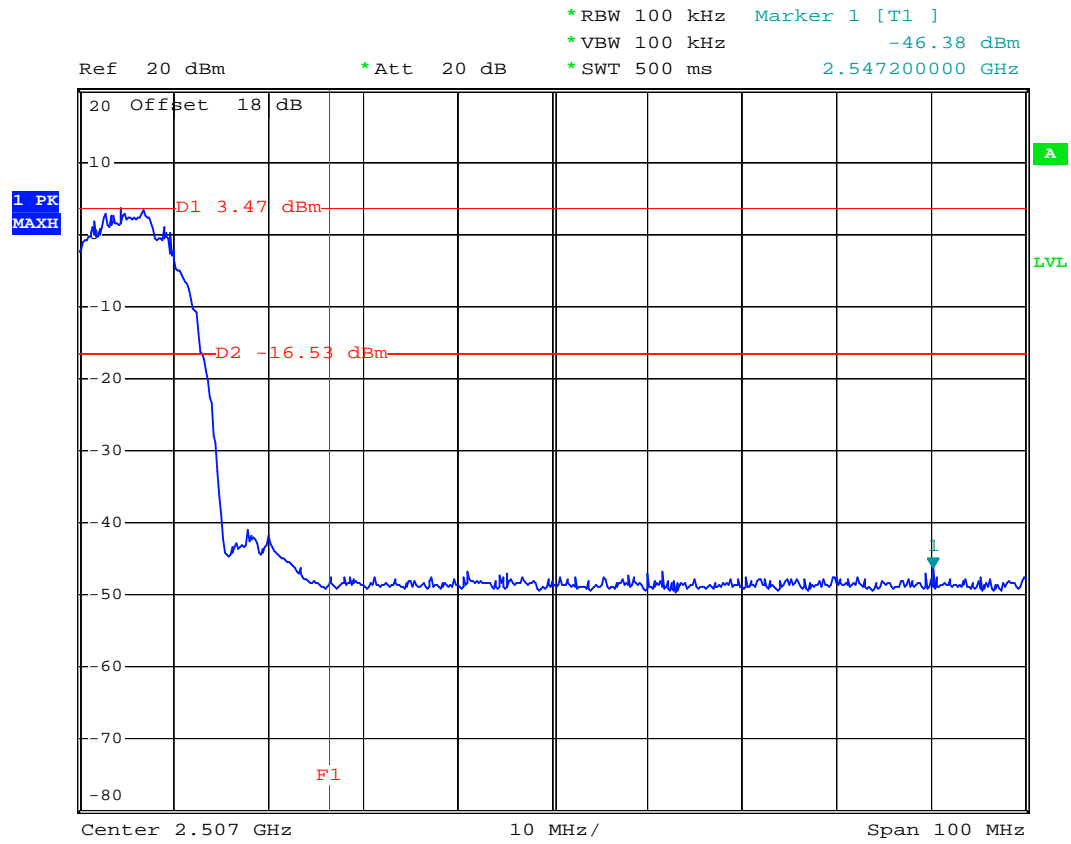

Date: 17.JUL.2007 20:54:00



WLAN 802.11g for Antenna 1

CH01

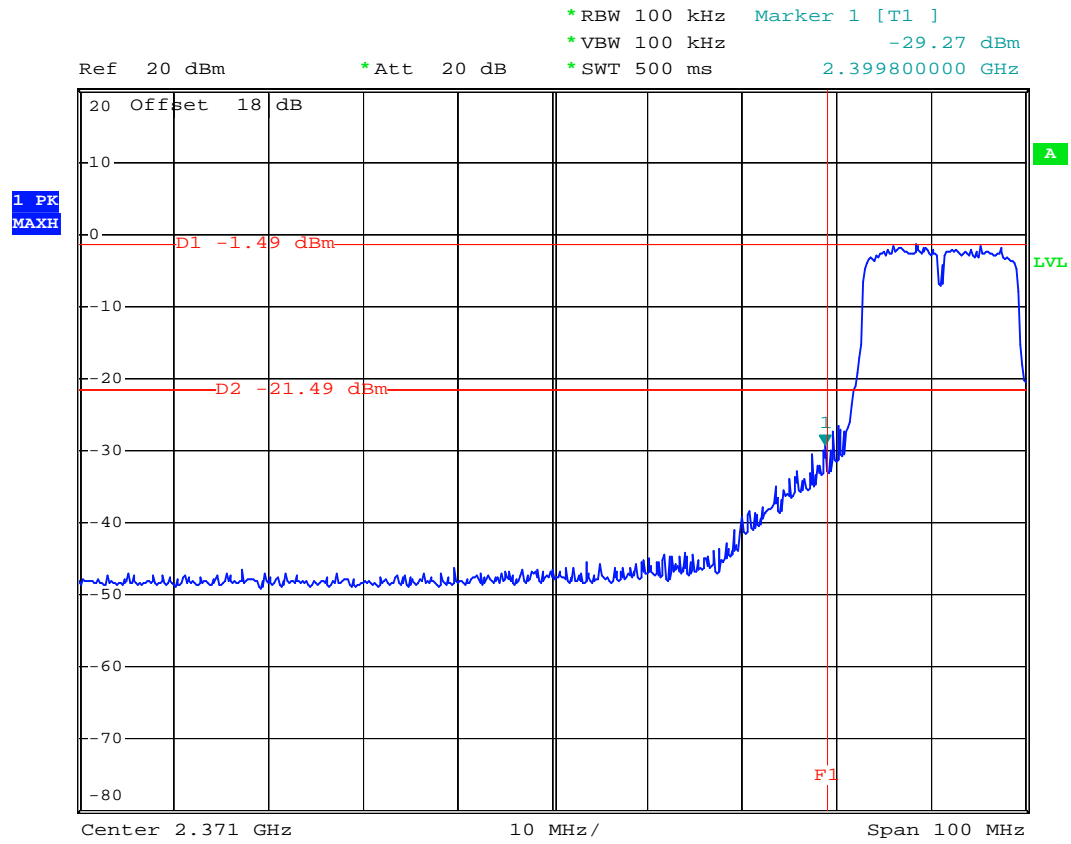

Date: 17.JUL.2007 21:39:53





WLAN 802.11b for Antenna 2 and 3  
CH01

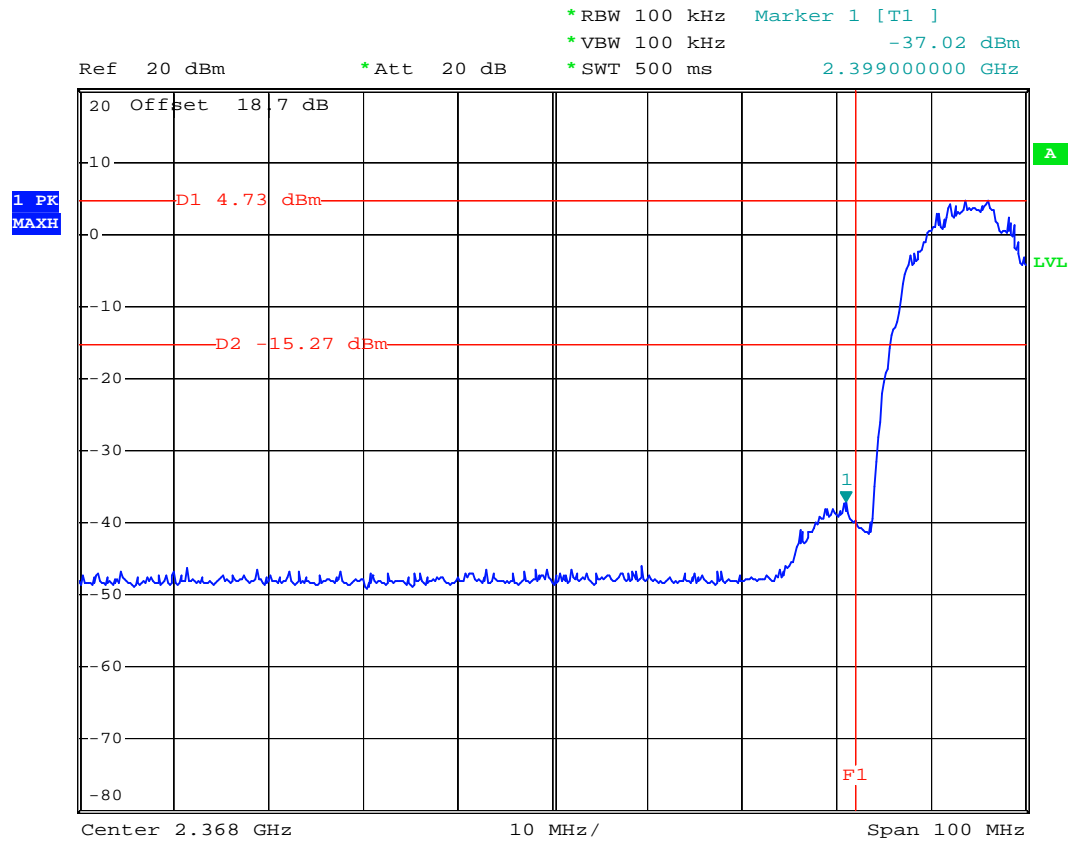

Date: 17.JUL.2007 16:57:45





WLAN 802.11b for Antenna 2 and 3  
CH11

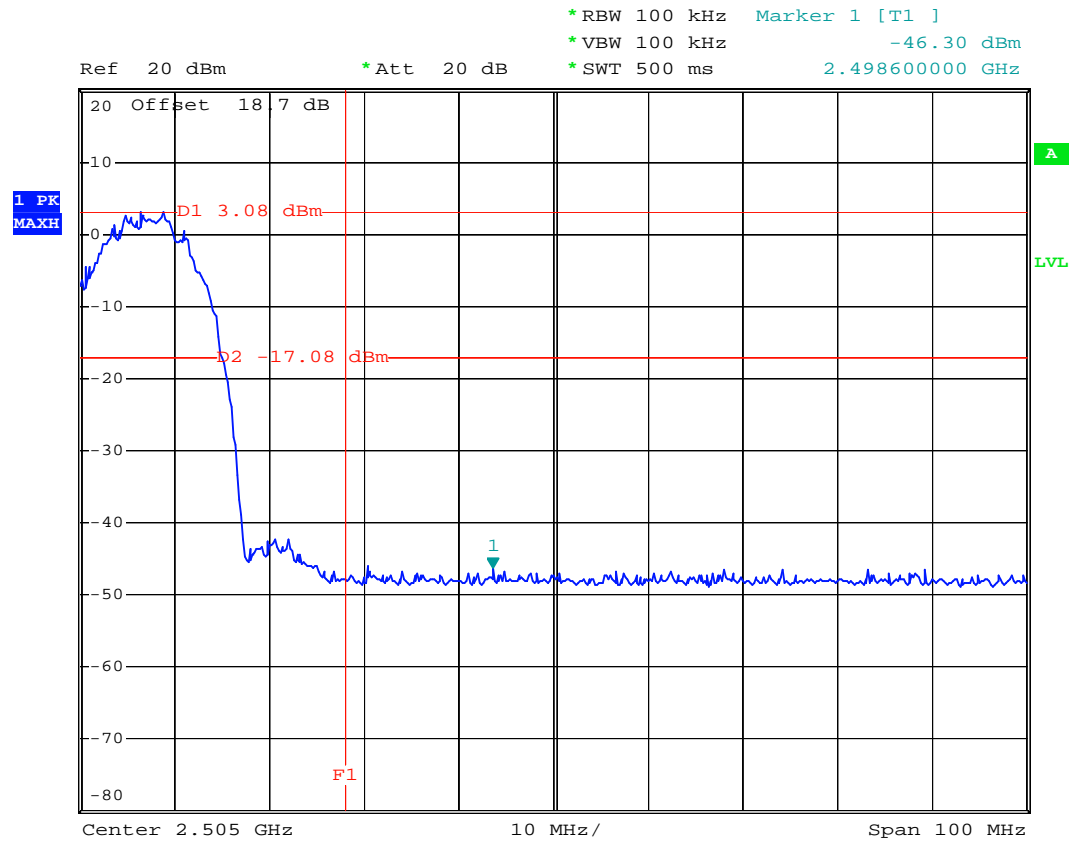

Date: 17.JUL.2007 17:00:41





WLAN 802.11g for Antenna 2 and 3  
CH11

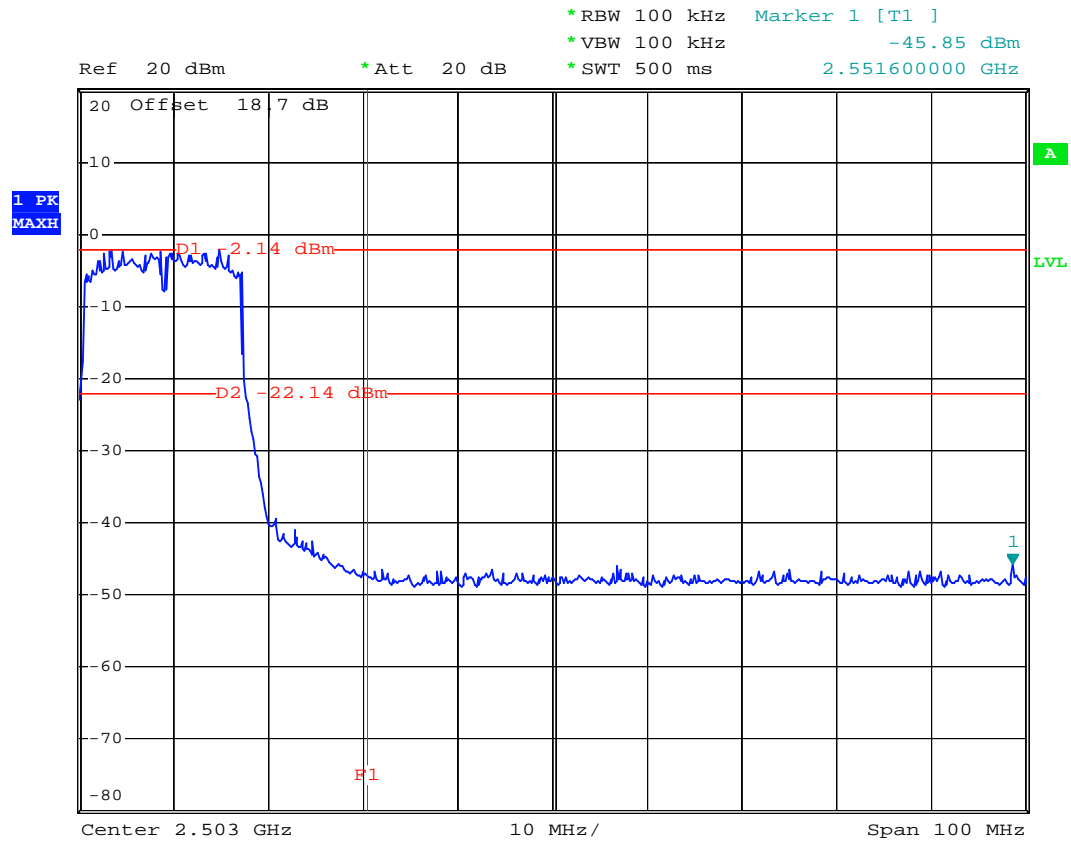

Date: 17.JUL.2007 18:10:32

## 5.5 Peak Output Power Measurement

### 5.5.1 Measuring Instruments :

As described in chapter 6 of this test report.

### 5.5.2 Test Procedure :

1. The antenna port ( RF output ) of the EUT was connected to the input ( RF input ) of a power meter for WLAN measurement. The power is equal to the reading level on power meter plus cable loss at the EUT antenna terminal.
2. The antenna port(RF output) of the EUT was connected to the input (RF input) of a spectrum analyzer for BT measurement. The cable loss has been offset before testing.

### 5.5.3 Test Setup Layout :

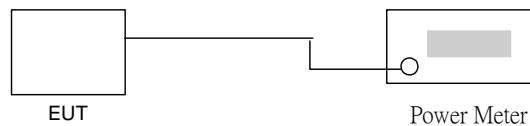

### 5.5.4 Test Result :

- Application Type : WLAN 802.11b/g for Antenna 1
- Temperature : 26~28°C
- Relative Humidity : 52~55%
- Test Enginner : Tony

#### **802.11b**

Channel	Frequency (MHz)	Measured Output Power (dBm)	Limits (Watt/dBm )
01	2412	17.61	1W/30 dBm
06	2437	17.42	1W/30 dBm
11	2462	17.08	1W/30 dBm

#### **802.11g**

Channel	Frequency (MHz)	Measured Output Power (dBm)	Limits (Watt/dBm )
01	2412	20.41	1W/30 dBm
06	2437	20.00	1W/30 dBm
11	2462	19.11	1W/30 dBm



- Application Type : WLAN 802.11b/g for Antenna2 and 3
- Temperature : 26~28°C
- Relative Humidity : 52~55%
- Test Enginner : Tony

**802.11b**

Channel	Frequency (MHz)	Measured Output Power (dBm)	Limits (Watt/dBm )
01	2412	17.78	1W/30 dBm
06	2437	17.54	1W/30 dBm
11	2462	17.61	1W/30 dBm

**802.11g**

Channel	Frequency (MHz)	Measured Output Power (dBm)	Limits (Watt/dBm )
01	2412	20.24	1W/30 dBm
06	2437	21.32	1W/30 dBm
11	2462	22.43	1W/30 dBm



## 5.6 Conducted Emission

### 5.6.1 Measuring Instruments

As described in chapter 6 of this test Report.

The receiver setting :

150 KHz ~ 30 MHz	Detector : Quasi – Peak and Average Bandwidth : 9 KHz
------------------	--

### 5.6.2 Test Procedures :

- a. The EUT was placed 0.4 meter from the conducting wall of the shielding room was kept at least 80 centimeters from any other grounded conducting surface.
- b. Connect EUT to the power port of a line impedance stabilization network (LISN).
- c. All the support units are connected to the other LISN.
- d. The LISN provides 50 ohm coupling impedance for the measuring instrument.
- e. The FCC states that a 50 ohm, 50 microhenry LISN should be used.
- f. Both sides of AC line were checked for maximum conducted interference.
- g. The frequency range from 150 kHz to 30 MHz was searched.
- h. Set the test-receiver system to Peak Detect Function and specified bandwidth with Maximum Hold Mode.



5.6.3 Test Data

- Temperature : 26~28°C
- Relative Humidity : 52~55%
- Test Enginner : Tony
- Test Mode : Mode 1

■ The test that passed at minimum margin was marked by the frame in the following table.

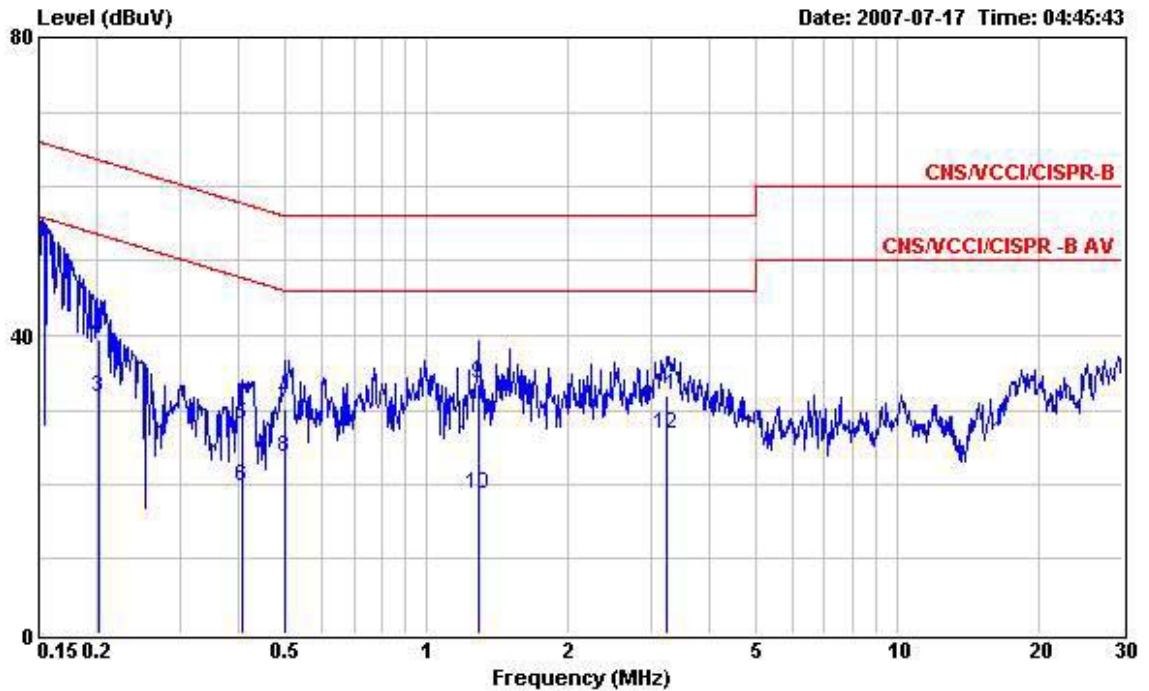

Site : CO01-HY  
 Condition : CNS/VCCI/CISPR-B 2001/004 200604 LINE  
 EUT : 802.11g USB Wireless adapter  
 Power : 120V/60Hz  
 Model : FR770311  
 Memo : Ping Mode+USB Charging+Antenna2  
 Memo :  
 Memo :

	Freq	Level	Over Limit	Limit Line	Read Level	Cable Loss	Probe Factor	Remark
	MHz	dBuV	dB	dBuV	dBuV	dB	dB	
1	0.150	31.09	-24.91	56.00	30.91	0.08	0.10	Average
2	0.150	51.32	-14.68	66.00	51.14	0.08	0.10	QP
3	0.201	31.76	-21.81	53.57	31.56	0.10	0.10	Average
4	0.201	39.59	-23.98	63.57	39.39	0.10	0.10	QP
5	0.406	28.06	-29.68	57.74	27.92	0.04	0.10	QP
6	0.406	19.67	-28.07	47.74	19.53	0.04	0.10	Average
7	0.502	30.23	-25.77	56.00	30.06	0.07	0.10	QP
8	0.502	23.55	-22.45	46.00	23.38	0.07	0.10	Average
9	1.294	33.41	-22.59	56.00	33.11	0.20	0.10	QP
10	1.294	18.68	-27.32	46.00	18.38	0.20	0.10	Average
11	3.240	32.06	-23.94	56.00	31.71	0.18	0.17	QP
12	3.240	26.80	-19.20	46.00	26.45	0.18	0.17	Average

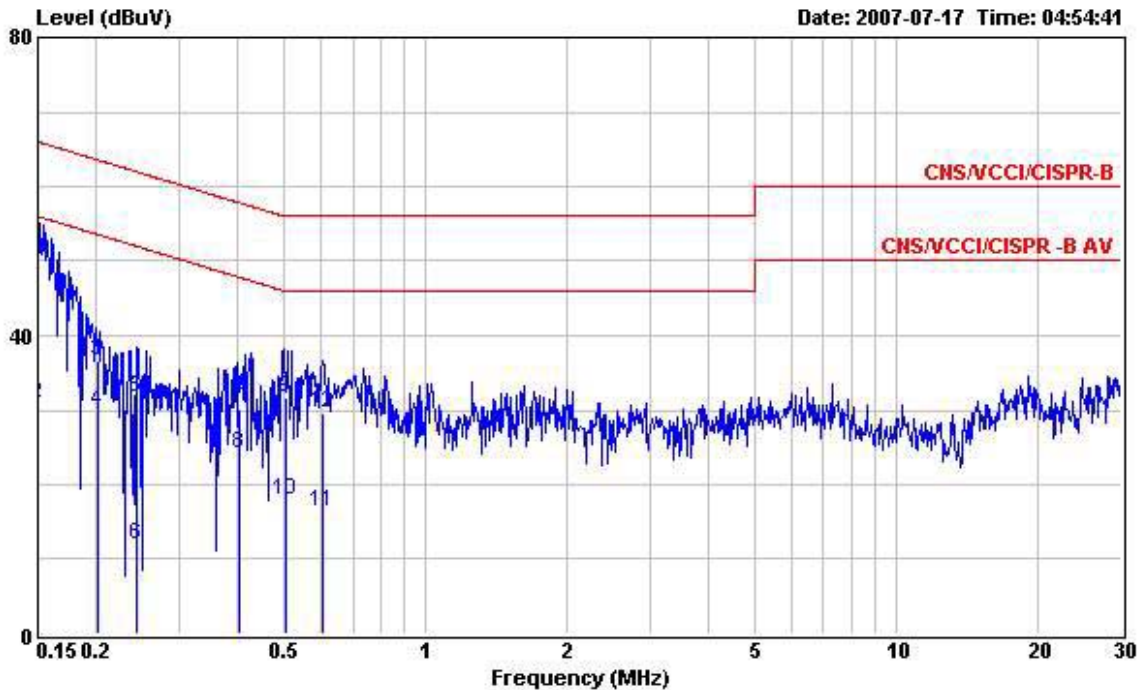

Site : CO01-HY  
 Condition : CNS/VCCI/CISPR-B 2001/004 200604 NEUTRAL  
 EUT : 802.11g USB Wireless adapter  
 Power : 120V/60Hz  
 Model : FR770311  
 Memo : Ping Mode+USB Charging+Antenna2  
 Memo :  
 Memo :

	Freq	Level	Over Limit	Limit Line	Read Level	Cable Loss	Probe Factor	Remark
	MHz	dBuV	dB	dBuV	dBuV	dB	dB	
1	0.150	50.75	-15.24	65.99	50.57	0.08	0.10	QP
2	0.150	31.00	-24.99	55.99	30.82	0.08	0.10	Average
3	0.201	36.56	-27.00	63.56	36.36	0.10	0.10	QP
4	0.201	29.77	-23.79	53.56	29.57	0.10	0.10	Average
5	0.244	31.63	-30.33	61.96	31.45	0.08	0.10	QP
6	0.244	11.99	-39.97	51.96	11.81	0.08	0.10	Average
7	0.402	30.18	-27.62	57.80	30.04	0.04	0.10	QP
8	0.402	24.08	-23.72	47.80	23.94	0.04	0.10	Average
9	0.505	31.58	-24.42	56.00	31.41	0.07	0.10	QP
10	0.505	17.83	-28.17	46.00	17.66	0.07	0.10	Average
11	0.604	16.25	-29.75	46.00	16.05	0.10	0.10	Average
12	0.604	29.63	-26.37	56.00	29.43	0.10	0.10	QP





## 5.7 Radiated Emission Measurement

### 5.7.1 Measuring Instruments

As described in chapter 6 of this Report.

The spectrum analyzer setting :

30 ~ 1000 MHz	Detector : Quasi – Peak Bandwidth : 120 KHz
1 ~ 25 GHz	Detector : Peak and Average Bandwidth : 1 MHz

### 5.7.2 Test Procedures

- a. The EUT was placed on a rotatable table top 0.8 meter above ground.
- b. The EUT was set 3 meters from the interference receiving antenna which was mounted on the top of a variable height antenna tower.
- c. The table was rotated 360 degrees to determine the position of the highest radiation.
- d. The antenna is a broadband antenna and its height is varied between one meter and four meters above ground to find the maximum value of the field strength for both horizontal polarization and vertical polarization of the antenna.
- e. For each suspected emission, the EUT was arranged to its worst case and then tune the antenna tower (from 1 m to 4 m) and turntable (from 0 degree to 360 degrees) to find the maximum reading.
- f. Set the test-receiver system to Peak or CISPR quasi-peak Detect Function and specified bandwidth with Maximum Hold Mode.
- g. For testing below 1GHz, If the emission level of the EUT in peak mode was 3 dB lower than the limit specified, then testing will be stopped and peak values of EUT will be reported, otherwise, the emissions will be repeated one by one using the quasi-peak method and reported.
- h. For testing above 1GHz, the emission level of the EUT in peak mode was 20dB lower than average limit (that means the emission level in average mode also complies with the limit in average mode), then testing will be stopped and peak values of EUT will be reported, otherwise, the emissions will be measured in average mode again and reported.

5.7.3 Typical Test Setup Layout of Radiated Emission

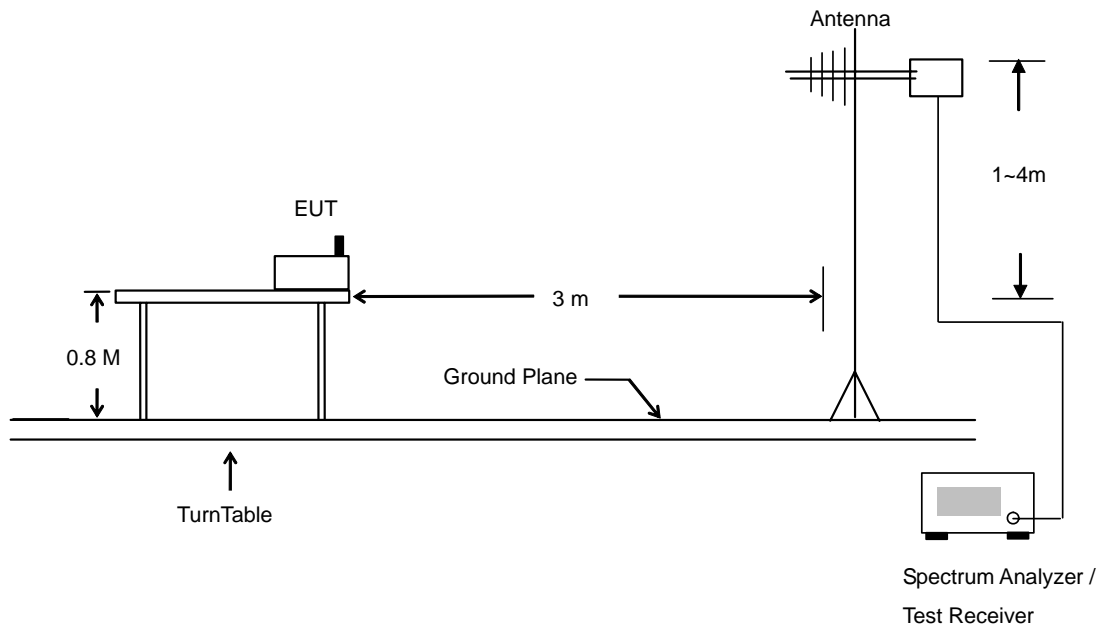



5.7.4 Test Data

- Temperature : 26°~28C
- Relative Humidity : 52~55%
- Test Enginner : Tony
- Test Mode : Mode 1
- Polarization : Horizontal

The test that passed at minimum margin was marked by the frame in the following table.

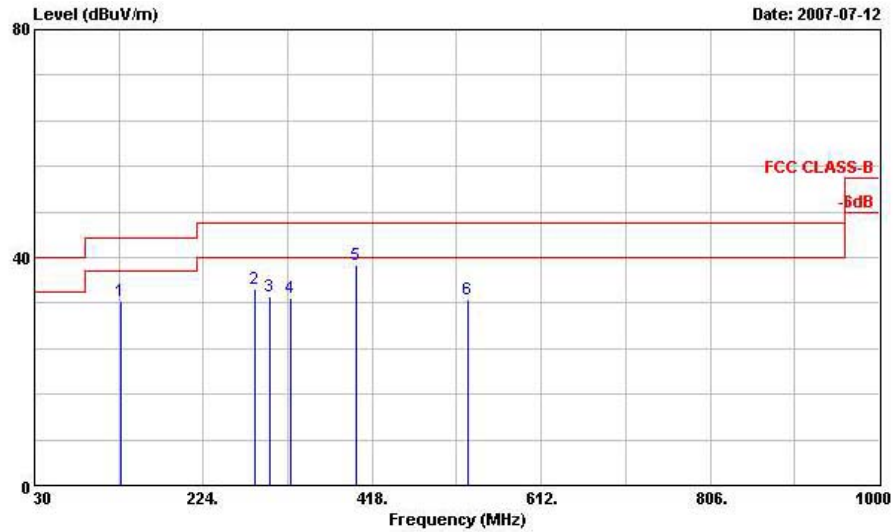

Site : 03CH04-HY  
 Condition: FCC CLASS-B 3m ANT2724 HORIZONTAL  
 EUT : 802.11g USB Wireless adapter  
 POWER : From Notebook  
 MODEL : FR 770310  
 MODE : 11b Tx\_Ch01;2412MHz  
 Data Rate: 11

	Freq	Level	Over Limit	Limit	ReadAntenna	Cable	Preamp	Ant	Table		
	MHz	dBuV/m	dB	dBuV/m	dBuV	dB/m	dB	dB	cm	deg	Remark
1	129.090	32.26	-11.24	43.50	52.26	11.55	1.31	32.86	---	---	Peak
2	283.530	34.44	-11.56	46.00	52.89	12.40	1.99	32.83	---	---	Peak
3	299.730	33.20	-12.80	46.00	51.67	12.31	2.03	32.81	---	---	Peak
4	323.800	32.97	-13.03	46.00	50.57	13.14	2.08	32.82	---	---	Peak
5 @	399.400	38.57	-7.43	46.00	53.35	15.75	2.33	32.86	100	201	Peak
6	528.200	32.62	-13.38	46.00	44.62	17.75	2.70	32.45	---	---	Peak

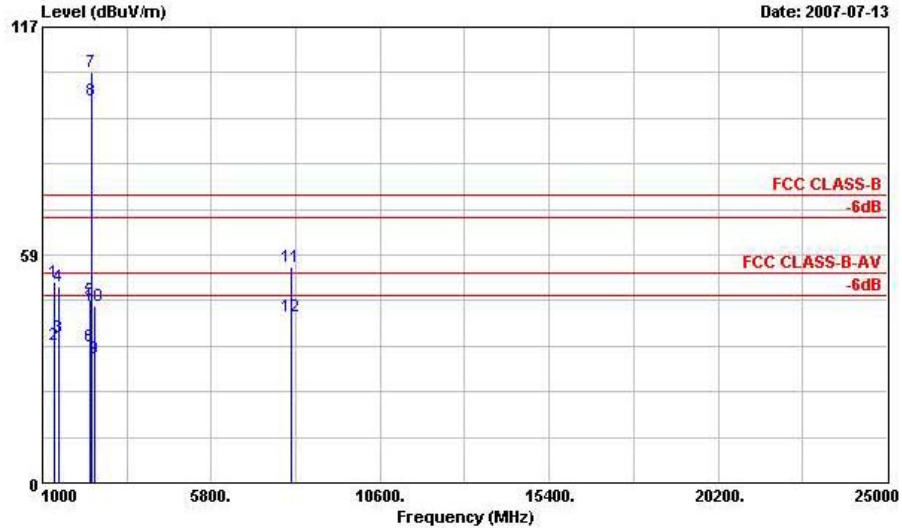

Site : 03CH04-HY  
 Condition: FCC CLASS-B 3m HF-ANT HORIZONTAL  
 EUT : 802.11g USB Wireless adapter  
 POWER : From Notebook  
 MODEL : FR 770310  
 MODE : 11b Tx\_Ch01;2412MHz  
 Data Rate: 11

	Freq	Level	Over Limit	Limit Line	ReadAntenna Level	Cable Factor	Preamp Loss	Ant Pos	Table Pos	Remark
	MHz	dBuV/m	dB	dBuV/m	dBuV	dB/m	dB	cm	deg	
1	1324.000	51.45	-22.55	74.00	56.15	26.65	2.60	33.95	100	0 Peak
2	1324.000	35.28	-18.72	54.00	39.98	26.65	2.60	33.95	100	124 Average
3	1460.000	37.26	-16.74	54.00	41.21	27.09	2.73	33.77	100	163 Average
4	1460.000	50.27	-23.73	74.00	54.22	27.09	2.73	33.77	100	0 Peak
5	2368.140	46.91	-27.09	74.00	46.37	30.59	3.74	33.78	100	0 Peak
6	2368.140	34.93	-19.07	54.00	34.34	30.65	3.71	33.78	100	100 Average
7 @	2412.000	105.47			104.93	30.56	3.76	33.78	100	0 Peak
8 @	2412.000	97.97			97.43	30.56	3.76	33.78	100	100 Average
9	2489.170	31.78	-22.22	54.00	31.34	30.40	3.84	33.80	100	100 Average
10	2489.170	45.34	-28.66	74.00	45.16	30.07	4.19	34.07	100	0 Peak
11	8058.000	55.53	-18.47	74.00	42.95	39.48	6.78	33.68	---	--- Peak
12	8058.000	42.78	-11.22	54.00	30.20	39.48	6.78	33.68	100	227 Average

Remark: #7 and #8 Fundamental Signal



- Polarization : Vertical

■ The test that passed at minimum margin was marked by the frame in the following table.

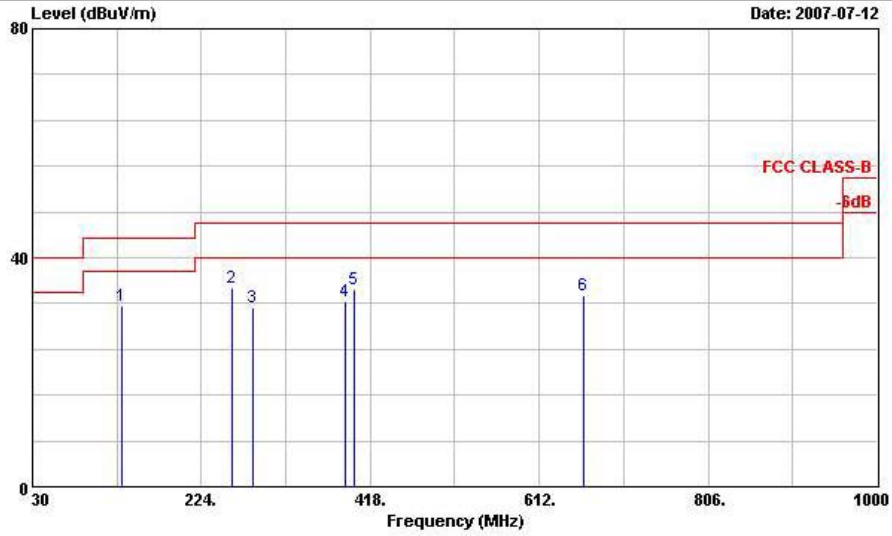

Site : 03CH04-HY  
 Condition: FCC CLASS-B 3m ANT2724 VERTICAL  
 EUT : 802.11g USB Wireless adapter  
 POWER : From Notebook  
 MODEL : FR 770310  
 MODE : 11b Tx\_Ch01;2412MHz  
 Data Rate: 11

	Freq	Level	Over	Limit	ReadAntenna	Cable	Preamp	Ant	Table	
	MHz	dBuV/m	dB	dBuV/m	Level	Loss	Factor	Pos	Pos	Remark
					Factor	Factor		cm	deg	
1	132.330	31.49	-12.01	43.50	51.74	11.28	1.33	32.87	---	--- Peak
2	259.770	34.67	-11.33	46.00	53.09	12.52	1.93	32.87	100	136 Peak
3	283.530	31.20	-14.80	46.00	49.65	12.40	1.99	32.83	---	--- Peak
4	388.900	32.33	-13.67	46.00	47.52	15.38	2.29	32.85	---	--- Peak
5	399.400	34.41	-11.59	46.00	49.19	15.75	2.33	32.86	---	--- Peak
6	662.600	33.45	-12.55	46.00	42.32	20.05	3.12	32.04	---	--- Peak

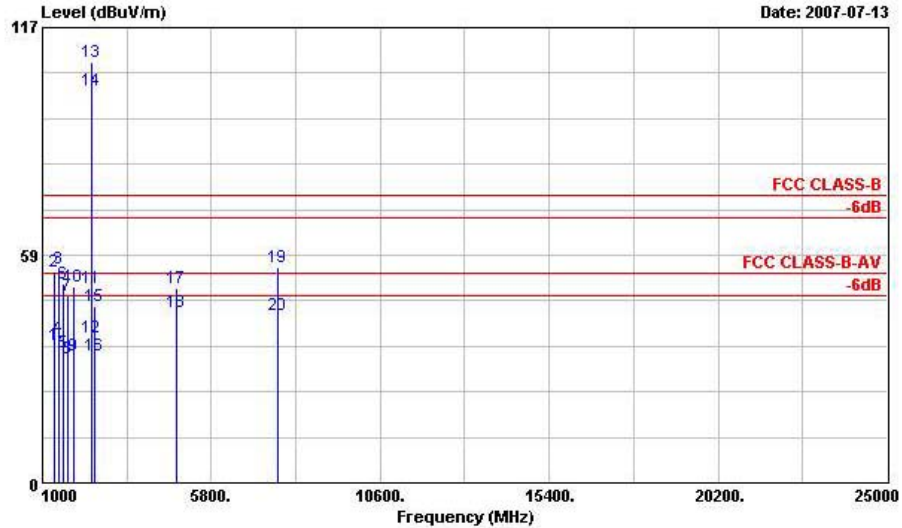

Site : 03CH04-HY  
 Condition: FCC CLASS-B 3m HF-ANT VERTICAL  
 EUT : 802.11g USB Wireless adapter  
 POWER : From Notebook  
 MODEL : FR 770310  
 MODE : 11b Tx\_Ch01;2412MHz  
 Data Rate: 11

	Freq	Level	Over	Limit	ReadAntenna	Cable	Preamp	Ant	Table	
	MHz	dBuV/m	dB	dBuV/m	Level	Loss	Factor	Pos	Pos	Remark
					Factor	Factor		cm	deg	
1	1324.000	35.43	-18.57	54.00	40.13	26.65	2.60	33.95	100	124 Average
2	1324.000	54.15	-19.85	74.00	58.85	26.65	2.60	33.95	100	0 Peak
3	1454.000	54.96	-19.04	74.00	58.91	27.09	2.73	33.77	100	0 Peak
4	1454.000	37.26	-16.74	54.00	41.21	27.09	2.73	33.77	100	163 Average
5	1596.000	33.62	-20.38	54.00	36.41	28.02	2.89	33.70	100	171 Average
6	1596.000	51.05	-22.95	74.00	53.84	28.02	2.89	33.70	100	0 Peak
7	1726.000	47.94	-26.06	74.00	49.50	29.11	3.02	33.70	100	0 Peak
8	1726.000	32.09	-21.91	54.00	33.65	29.11	3.02	33.70	100	217 Average
9	1868.000	32.58	-21.42	54.00	32.89	30.21	3.18	33.70	100	217 Average
10	1868.000	50.28	-23.72	74.00	50.59	30.21	3.18	33.70	---	--- Peak
11	2388.090	50.04	-23.96	74.00	49.50	30.59	3.74	33.78	100	0 Peak
12	2388.090	37.49	-16.51	54.00	36.94	30.59	3.74	33.78	100	357 Average
13 @	2412.000	108.22			107.68	30.56	3.76	33.78	100	0 Peak
14 @	2412.000	100.72			100.18	30.56	3.76	33.78	100	357 Average
15	2486.000	45.31	-28.69	74.00	44.84	30.43	3.84	33.80	100	0 Peak
16	2486.000	32.82	-21.18	54.00	32.35	30.43	3.84	33.80	100	357 Average
17	4821.000	50.18	-23.82	74.00	45.15	33.45	5.88	34.30	100	0 Peak
18	4821.000	44.03	-9.97	54.00	39.00	33.45	5.88	34.30	100	252 Average
19	7689.000	55.27	-18.73	74.00	43.12	39.25	6.64	33.73	---	--- Peak
20	7689.000	43.19	-30.81	74.00	31.04	39.25	6.64	33.73	100	97 Peak

Remark: #13 and #14 Fundamental Signal



- Test Mode : Mode 2
- Polarization : Horizontal

■ The test that passed at minimum margin was marked by the frame in the following table.

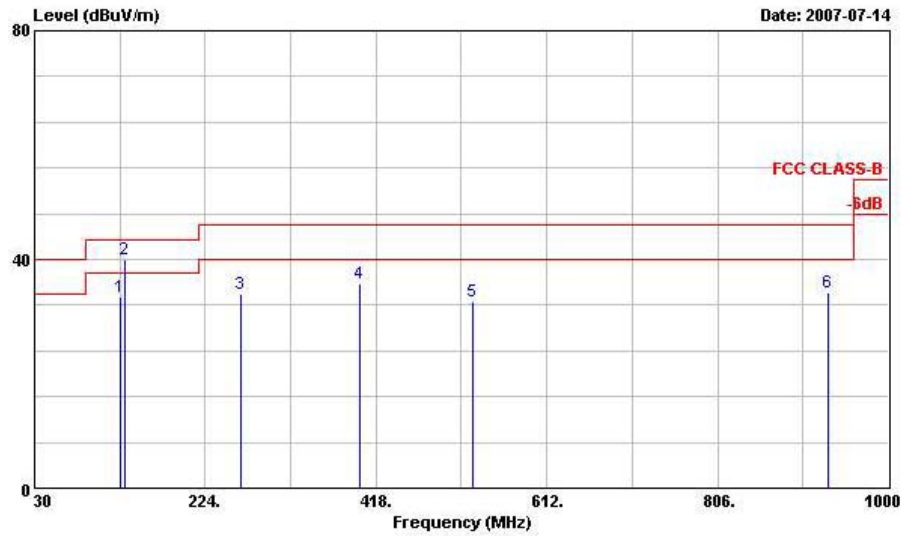

Site : 03CH04-HY  
 Condition: FCC CLASS-B 3m ANT2724 HORIZONTAL  
 EUT : 802.11g USB Wireless adapter  
 POWER : From Notebook  
 MODEL : FR 770310  
 MODE : 11b Tx\_Ch06;2437MHz  
 Data Rate: 11

	Freq	Level	Over Limit	Limit Line	ReadAntenna Level	Antenna Factor	Cable Loss	Preamp	Ant Pos	Table Pos	Remark
	MHz	dBuV/m	dB	dBuV/m	dBuV	dB/m	dB	dB	cm	deg	
1	127.740	33.50	-10.00	43.50	53.42	11.64	1.30	32.86	---	---	Peak
2	132.330	39.91	-3.59	43.50	60.16	11.28	1.33	32.87	112	38	Peak
3	264.090	33.88	-12.12	46.00	52.31	12.50	1.94	32.86	---	---	Peak
4	399.400	35.67	-10.33	46.00	50.45	15.75	2.33	32.86	---	---	Peak
5	528.200	32.51	-13.49	46.00	44.51	17.75	2.70	32.45	---	---	Peak
6	932.100	34.22	-11.78	46.00	37.74	24.32	3.58	31.42	---	---	Peak



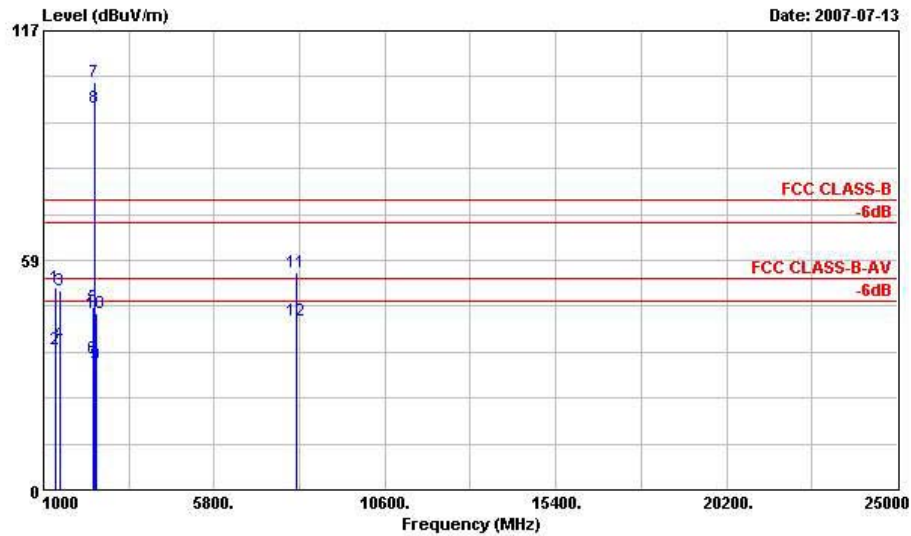

Site : 03CH04-HY  
 Condition: FCC CLASS-B 3m HF-ANT HORIZONTAL  
 EUT : 802.11g USB Wireless adapter  
 POWER : From Notebook  
 MODEL : FR 770310  
 MODE : 11b Tx\_Ch06;2437MHz  
 Data Rate: 11

	Freq	Level	Over	Limit	ReadAntenna	Cable	Preamp	Ant	Table	Remark
	MHz	dBuV/m	dB	dBuV/m	dBuV	dB/m	dB	cm	deg	
1	1324.000	51.52	-22.48	74.00	56.22	26.65	2.60	33.95	100	0 Peak
2	1324.000	35.60	-18.40	54.00	40.30	26.65	2.60	33.95	100	124 Average
3	1460.000	50.91	-23.09	74.00	54.86	27.09	2.73	33.77	100	0 Peak
4	1460.000	37.26	-16.74	54.00	41.21	27.09	2.73	33.77	100	163 Average
5	2382.010	46.48	-27.52	74.00	45.94	30.59	3.74	33.78	100	0 Peak
6	2382.010	33.45	-20.55	54.00	32.87	30.62	3.74	33.78	100	272 Average
7 @	2437.000	103.76			103.26	30.49	3.79	33.79	100	0 Peak
8 @	2437.000	97.26			96.76	30.49	3.79	33.79	100	272 Average
9	2486.700	32.09	-21.91	54.00	31.62	30.43	3.84	33.80	100	272 Average
10	2486.700	45.19	-28.81	74.00	44.72	30.43	3.84	33.80	100	0 Peak
11	8097.000	55.49	-18.51	74.00	42.94	39.47	6.81	33.73	---	--- Peak
12	8097.000	43.05	-10.95	54.00	30.50	39.47	6.81	33.73	100	166 Average

Remark: #7 and #8 Fundamental Signal





- Polarization : Vertical

■ The test that passed at minimum margin was marked by the frame in the following table.

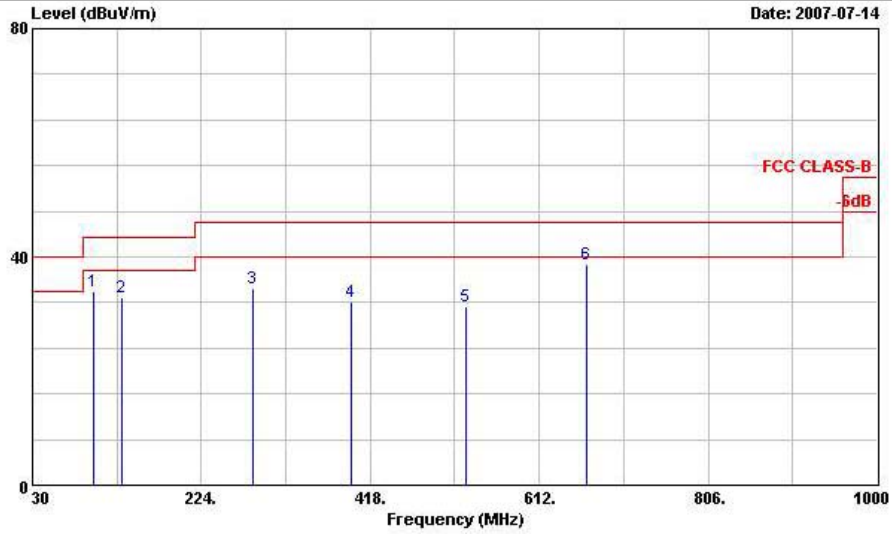

Site : 03CH04-HY  
 Condition: FCC CLASS-B 3m ANT2724 VERTICAL  
 EUT : 802.11g USB Wireless adapter  
 POWER : From Notebook  
 MODEL : FR 770310  
 MODE : 11b Tx\_Ch06;2437MHz  
 Data Rate: 11

	Freq	Level	Over	Limit	ReadAntenna	Cable	Preamp	Ant	Table	
	MHz	dBuV/m	dB	dBuV/m	Level	Loss	Factor	Pos	Pos	Remark
					Factor	Factor		cm	deg	
1	100.740	33.99	-9.51	43.50	57.64	8.08	1.11	32.85	---	--- Peak
2	133.140	32.95	-10.55	43.50	53.28	11.20	1.34	32.87	---	--- Peak
3	283.530	34.46	-11.54	46.00	52.91	12.40	1.99	32.83	---	--- Peak
4	396.600	32.05	-13.95	46.00	46.94	15.65	2.32	32.86	---	--- Peak
5	528.200	31.41	-14.59	46.00	43.41	17.75	2.70	32.45	---	--- Peak
6	666.100	38.63	-7.37	46.00	47.49	20.06	3.12	32.04	105	271 Peak

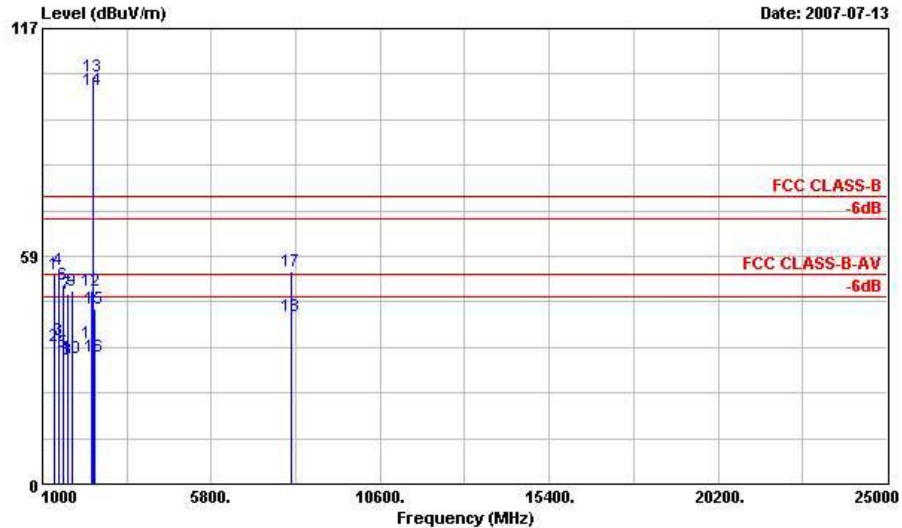

Site : 03CH04-HY  
 Condition: FCC CLASS-B 3m HF-ANT VERTICAL  
 EUT : 802.11g USB Wireless adapter  
 POWER : From Notebook  
 MODEL : FR 770310  
 MODE : 11b Tx\_Ch06;2437MHz  
 Data Rate: 11

	Freq	Level	Over	Limit	ReadAntenna	Cable	Preamp	Ant	Table		
	MHz	dBuV/m	dB	dBuV/m	dBuV	dB/m	dB	dB	cm	deg	
1	1324.000	54.00	-20.00	74.00	58.70	26.65	2.60	33.95	100	0 Peak	
2	1324.000	35.28	-18.72	54.00	39.98	26.65	2.60	33.95	100	124 Average	
3	1454.000	37.10	-16.90	54.00	41.05	27.09	2.73	33.77	100	163 Average	
4	1454.000	55.02	-18.98	74.00	58.97	27.09	2.73	33.77	100	0 Peak	
5	1596.000	33.72	-20.28	54.00	36.51	28.02	2.89	33.70	100	171 Average	
6	1596.000	51.02	-22.98	74.00	53.81	28.02	2.89	33.70	100	0 Peak	
7	1732.000	48.88	-25.12	74.00	50.44	29.11	3.02	33.70	100	0 Peak	
8	1732.000	32.00	-22.00	54.00	33.56	29.11	3.02	33.70	100	217 Average	
9	1854.000	49.63	-24.37	74.00	50.08	30.07	3.18	33.70	100	0 Peak	
10	1854.000	32.43	-21.57	54.00	32.88	30.07	3.18	33.70	100	217 Average	
11	2390.000	36.27	-17.73	54.00	35.73	30.59	3.74	33.78	100	357 Average	
12	2390.000	49.77	-24.23	74.00	49.23	30.59	3.74	33.78	100	0 Peak	
13 @	2437.000	104.68			104.18	30.49	3.79	33.79	100	0 Peak	
14 @	2437.000	101.11			100.61	30.49	3.79	33.79	100	357 Average	
15	2487.650	44.94	-29.06	74.00	44.47	30.43	3.84	33.80	100	0 Peak	
16	2487.650	32.62	-21.38	54.00	32.18	30.40	3.84	33.80	100	357 Average	
17	8082.000	54.56	-19.44	74.00	42.02	39.47	6.80	33.73	---	---	Peak
18	8082.000	43.04	-10.96	54.00	30.50	39.47	6.80	33.73	100	168 Average	

Remark: #13 and #14 Fundamental Signal



- Test Mode : Mode 3
- Polarization : Horizontal

The test that passed at minimum margin was marked by the frame in the following table.

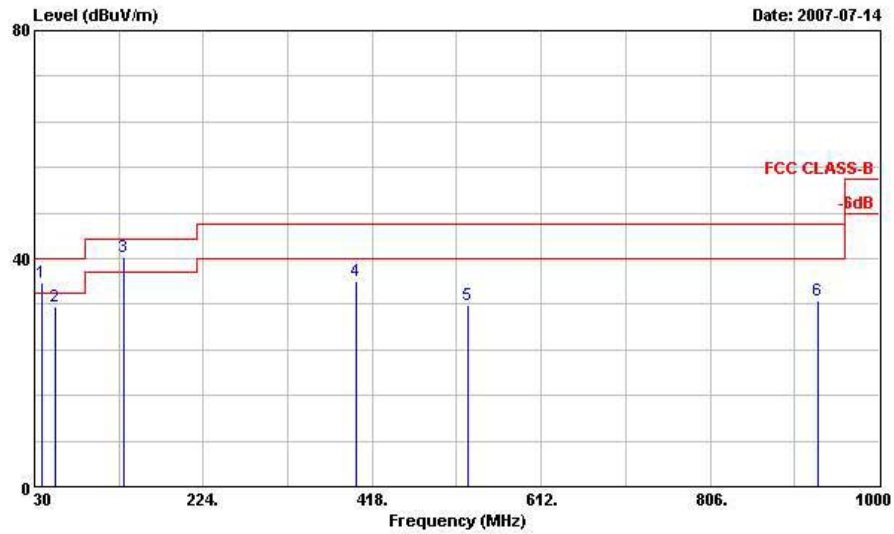

Site : 03CH04-HY  
 Condition: FCC CLASS-B 3m ANT2724 HORIZONTAL  
 EUT : 802.11g USB Wireless adapter  
 POWER : From Notebook  
 MODEL : FR 770310  
 MODE : 11b Tx\_Ch11;2462MHz  
 Data Rate: 11

	Freq	Level	Over	Limit	ReadAntenna	Cable	Preamp	Ant	Table	
	MHz	dBuV/m	dB	dBuV/m	dBuV	Loss	Factor	Pos	Pos	Remark
						dB	dB	cm	deg	
1	38.910	35.68	-4.32	40.00	55.20	12.71	0.71	32.94	---	Peak
2	53.490	31.50	-8.50	40.00	57.64	5.93	0.81	32.88	---	Peak
3	132.600	40.15	-3.35	43.50	60.48	11.20	1.34	32.87	105	225 Peak
4	399.400	36.00	-10.00	46.00	50.78	15.75	2.33	32.86	---	Peak
5	528.200	31.90	-14.10	46.00	43.90	17.75	2.70	32.45	---	Peak
6	929.300	32.51	-13.49	46.00	36.10	24.25	3.58	31.42	---	Peak

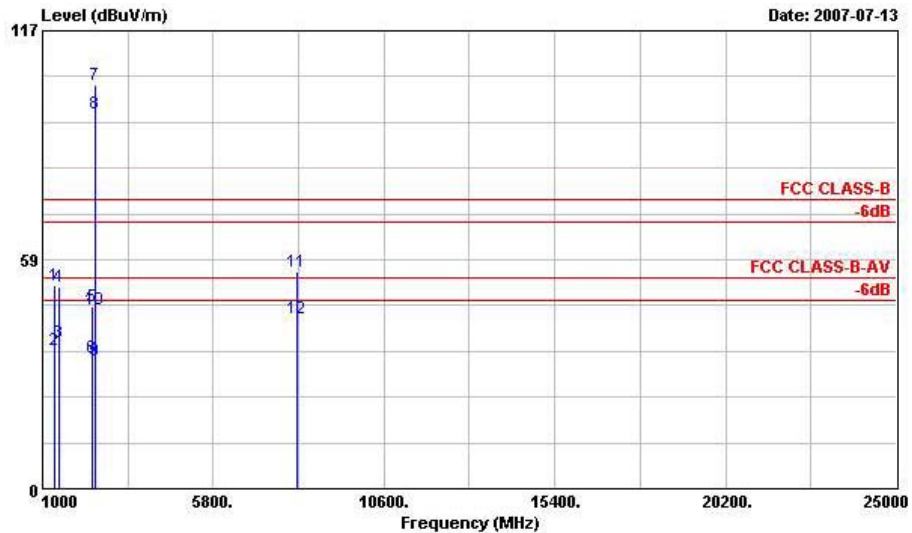

Site : 03CH04-HY  
 Condition: FCC CLASS-B 3m HF-ANT HORIZONTAL  
 EUT : 802.11g USB Wireless adapter  
 POWER : From Notebook  
 MODEL : FR 770310  
 MODE : 11b Tx\_Ch11;2462MHz  
 Data Rate: 11

	Freq	Level	Over Limit	Limit Line	ReadAntenna Level	Antenna Factor	Cable Loss	Preamp Factor	Ant Pos	Table Pos	Remark
	MHz	dBuV/m	dB	dBuV/m	dBuV	dB/m	dB	dB	cm	deg	
1	1324.000	51.85	-22.15	74.00	56.55	26.65	2.60	33.95	100	0	Peak
2	1324.000	35.28	-18.72	54.00	39.98	26.65	2.60	33.95	100	124	Average
3	1454.000	37.18	-16.82	54.00	41.13	27.09	2.73	33.77	100	163	Average
4	1454.000	51.38	-22.62	74.00	55.33	27.09	2.73	33.77	100	0	Peak
5	2383.530	46.53	-27.47	74.00	45.95	30.62	3.74	33.78	100	0	Peak
6	2383.530	33.65	-20.35	54.00	33.07	30.62	3.74	33.78	100	272	Average
7 X	2462.000	103.10			102.62	30.46	3.81	33.79	100	0	Peak
8 X	2462.000	95.76			95.28	30.46	3.81	33.79	100	272	Average
9	2487.460	32.58	-21.42	54.00	32.11	30.43	3.84	33.80	100	272	Average
10	2487.460	45.81	-28.19	74.00	45.34	30.43	3.84	33.80	100	0	Peak
11	8142.000	55.58	-18.42	74.00	43.11	39.44	6.83	33.81	---	---	Peak
12	8142.000	43.67	-10.33	54.00	31.20	39.44	6.83	33.81	100	114	Average

Remark: #7 and #8 Fundamental Signal



- Polarization : Vertical

■ The test that passed at minimum margin was marked by the frame in the following table.

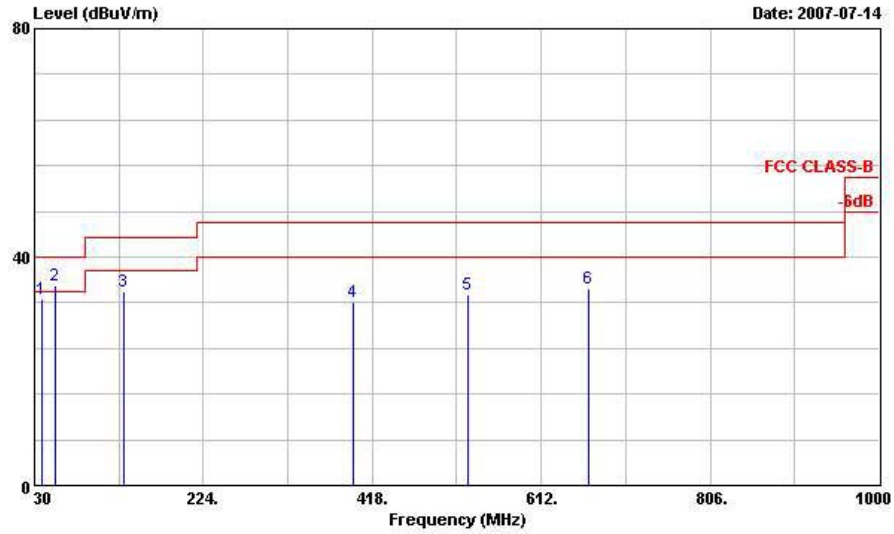

Site : 03CH04-HY  
 Condition: FCC CLASS-B 3m ANT2724 VERTICAL  
 EUT : 802.11g USB Wireless adapter  
 POWER : From Notebook  
 MODEL : FR 770310  
 MODE : 11b Tx\_Ch11;2462MHz  
 Data Rate: 11

	Freq MHz	Level dBuV/m	Over Limit dB	Limit Line dBuV/m	ReadAntenna		Cable Preamp		Ant Pos cm	Table Pos deg	Remark
					Level dBuV	Factor dB/m	Loss dB	Factor dB			
1	39.180	32.64	-7.36	40.00	52.16	12.71	0.71	32.94	---	---	Peak
2	53.760	34.90	-5.10	40.00	61.04	5.93	0.81	32.88	113	74	Peak
3	133.140	33.95	-9.55	43.50	54.28	11.20	1.34	32.87	---	---	Peak
4	396.600	32.15	-13.85	46.00	47.04	15.65	2.32	32.86	---	---	Peak
5	528.200	33.42	-12.58	46.00	45.42	17.75	2.70	32.45	---	---	Peak
6	666.100	34.38	-11.62	46.00	43.24	20.06	3.12	32.04	---	---	Peak

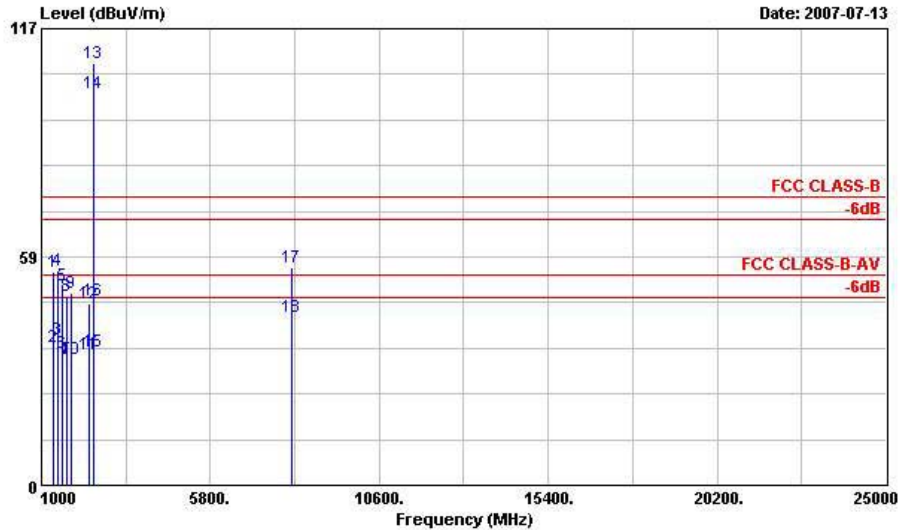

Site : 03CH04-HY  
 Condition: FCC CLASS-B 3m HF-ANT VERTICAL  
 EUT : 802.11g USB Wireless adapter  
 POWER : From Notebook  
 MODEL : FR 770310  
 MODE : 11b Tx\_Ch11;2462MHz  
 Data Rate: 11

	Freq	Level	Over	Limit	Read	Antenna	Cable	Preamp	Ant	Table	
	MHz	dBuV/m	Limit	Line	Level	Factor	Loss	Factor	Pos	Pos	Remark
			dB	dBuV/m	dBuV	dB/m	dB	dB	cm	deg	
1	1324.000	54.46	-19.54	74.00	59.16	26.65	2.60	33.95	100	0	Peak
2	1324.000	35.29	-18.71	54.00	39.99	26.65	2.60	33.95	100	124	Average
3	1454.000	37.17	-16.83	54.00	41.12	27.09	2.73	33.77	100	163	Average
4	1454.000	55.05	-18.95	74.00	59.00	27.09	2.73	33.77	100	0	Peak
5	1596.000	51.06	-22.94	74.00	53.85	28.02	2.89	33.70	100	0	Peak
6	1596.000	33.70	-20.30	54.00	36.49	28.02	2.89	33.70	100	171	Average
7	1732.000	32.15	-21.85	54.00	33.71	29.11	3.02	33.70	100	217	Average
8	1732.000	48.64	-25.36	74.00	50.20	29.11	3.02	33.70	100	0	Peak
9	1854.000	49.44	-24.56	74.00	49.89	30.07	3.18	33.70	100	0	Peak
10	1854.000	32.43	-21.57	54.00	32.88	30.07	3.18	33.70	100	217	Average
11	2341.500	33.60	-20.40	54.00	33.00	30.68	3.69	33.77	100	60	Average
12	2341.500	46.40	-27.60	74.00	45.82	30.62	3.74	33.78	100	0	Peak
13 X	2462.000	108.01			107.53	30.46	3.81	33.79	100	0	Peak
14 @	2462.000	100.27			99.79	30.46	3.81	33.79	100	60	Average
15	2488.220	34.35	-19.65	54.00	33.91	30.40	3.84	33.80	100	60	Average
16	2488.220	47.34	-26.66	74.00	46.87	30.43	3.84	33.80	100	0	Peak
17	8109.000	55.65	-18.35	74.00	43.15	39.46	6.81	33.77	---	---	Peak
18	8109.000	43.20	-10.80	54.00	30.70	39.46	6.81	33.77	100	304	Average

Remark: #13 and #14 Fundamental Signal





Test Mode : Mode 4

- Polarization : Horizontal

■ The test that passed at minimum margin was marked by the frame in the following table.

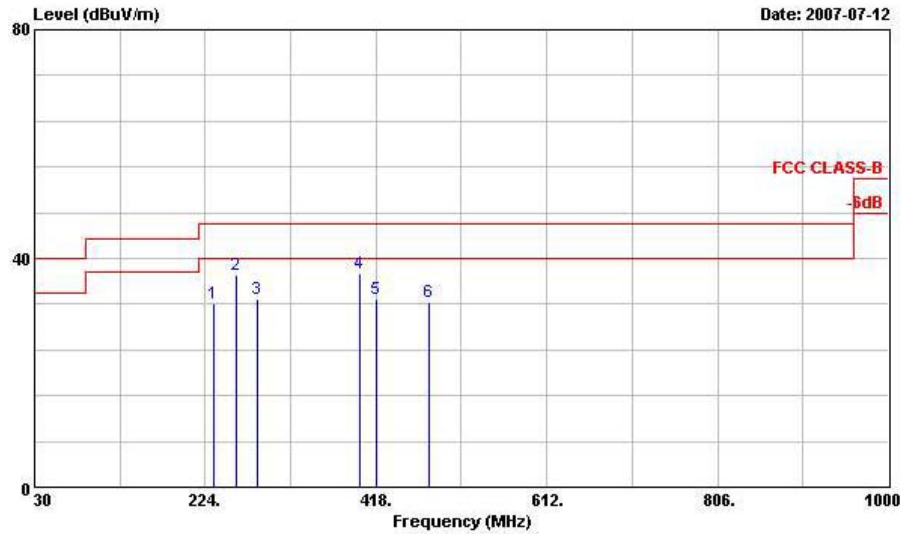

Site : 03CH04-HY  
 Condition: FCC CLASS-B 3m ANT2724 HORIZONTAL  
 EUT : 802.11g USB Wireless adapter  
 POWER : From Notebook  
 MODEL : FR 770310  
 MODE : 11b Tx\_Ch01;2412MHz  
 Data Rate: 11

	Freq	Level	Over Limit	Limit Line	ReadAntenna Level	Antenna Factor	Cable Loss	Preamp Factor	Ant Pos	Table Pos	Remark
	MHz	dBuV/m	dB	dBuV/m	dBuV	dB/m	dB	dB	cm	deg	
1	232.770	32.04	-13.96	46.00	51.84	11.24	1.80	32.84	---	---	Peak
2	259.770	37.03	-8.97	46.00	55.45	12.52	1.93	32.87	---	---	Peak
3	283.530	32.93	-13.07	46.00	51.38	12.40	1.99	32.83	---	---	Peak
4	399.400	37.27	-8.73	46.00	52.05	15.75	2.33	32.86	100	252	Peak
5	419.000	33.01	-12.99	46.00	47.46	15.97	2.39	32.81	---	---	Peak
6	478.500	32.28	-13.72	46.00	45.75	16.65	2.55	32.68	---	---	Peak

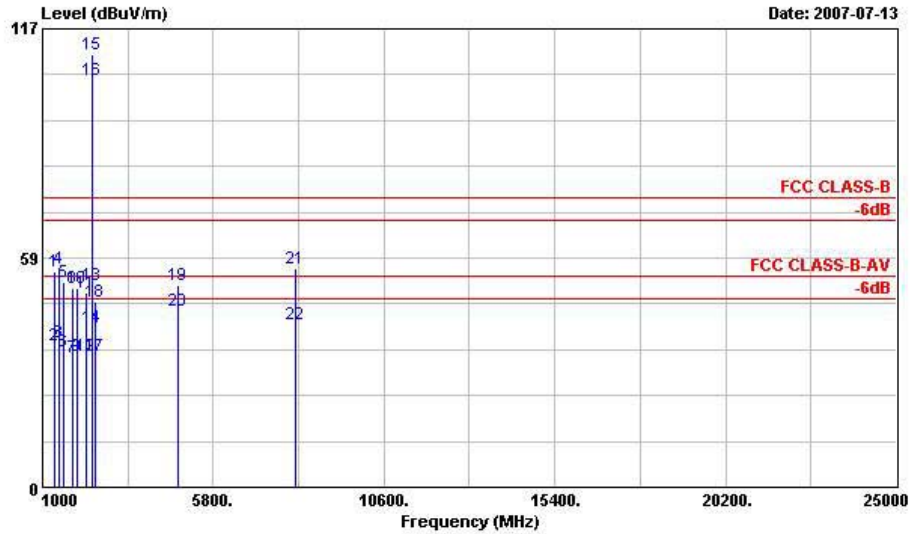

Site : 03CH04-HY  
 Condition: FCC CLASS-B 3m HF-ANT HORIZONTAL  
 EUT : 802.11g USB Wireless adapter  
 POWER : From Notebook  
 MODEL : FR 770310  
 MODE : 11b Tx\_Ch01;2412MHz  
 Data Rate: 11

	Freq	Level	Over Limit	Limit Line	ReadAntenna	Cable	Preamp	Ant	Table	Remark
	MHz	dBuV/m	dB	dBuV/m	dBuV	dB/m	dB	dB	cm	deg
1	1324.000	54.98	-19.02	74.00	59.68	26.65	2.60	33.95	100	0 Peak
2	1324.000	36.22	-17.78	54.00	40.92	26.65	2.60	33.95	100	120 Average
3	1460.000	36.88	-17.12	54.00	40.83	27.09	2.73	33.77	100	133 Average
4	1460.000	55.83	-18.17	74.00	59.78	27.09	2.73	33.77	100	0 Peak
5	1590.000	52.46	-21.54	74.00	55.25	28.02	2.89	33.70	100	0 Peak
6	1590.000	34.46	-19.54	54.00	37.25	28.02	2.89	33.70	100	251 Average
7	1854.000	33.11	-20.89	54.00	33.56	30.07	3.18	33.70	100	213 Average
8	1854.000	50.79	-23.21	74.00	51.24	30.07	3.18	33.70	100	0 Peak
9	1988.000	33.67	-20.33	54.00	32.89	31.16	3.31	33.70	100	237 Average
10	1988.000	50.84	-23.16	74.00	50.06	31.16	3.31	33.70	100	0 Peak
11	2210.000	49.51	-24.49	74.00	48.78	30.93	3.54	33.74	100	0 Peak
12	2210.000	33.51	-20.49	54.00	32.78	30.93	3.54	33.74	100	357 Average
13	2390.000	51.53	-22.47	74.00	50.99	30.59	3.74	33.78	100	0 Peak
14	2390.000	40.92	-13.08	54.00	40.38	30.59	3.74	33.78	100	130 Average
15 @	2412.000	110.56			110.02	30.56	3.76	33.78	100	0 Peak
16 @	2412.000	103.89			103.35	30.56	3.76	33.78	100	130 Average
17	2494.000	33.56	-20.44	54.00	33.12	30.40	3.84	33.80	100	130 Average
18	2494.000	47.50	-26.50	74.00	47.06	30.40	3.84	33.80	100	0 Peak
19	4821.000	51.58	-22.42	74.00	46.55	33.45	5.88	34.30	100	0 Peak
20	4821.000	45.10	-8.90	54.00	40.07	33.45	5.88	34.30	100	255 Average

Remark: #15 and #16 Fundamental Signal





- Polarization : Vertical

■ The test that passed at minimum margin was marked by the frame in the following table.

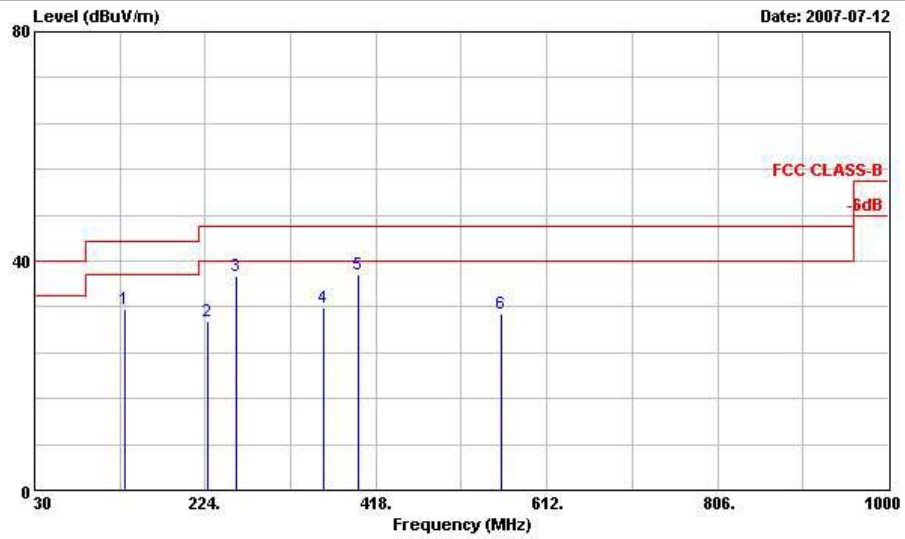

Site : 03CH04-HY  
 Condition: FCC CLASS-B 3m ANT2724 VERTICAL  
 EUT : 802.11g USB Wireless adapter  
 POWER : From Notebook  
 MODEL : FR 770310  
 MODE : 11b Tx\_Ch01;2412MHz  
 Data Rate: 11

	Freq	Level	Over Limit	Limit Line	ReadAntenna	Cable	Preamp	Ant	Table	Remark	
	MHz	dBuV/m	dB	dBuV/m	dBuV	dB/m	dB	dB	cm	deg	
1	133.140	31.71	-11.79	43.50	52.04	11.20	1.34	32.87	---	---	Peak
2	227.370	29.56	-16.44	46.00	49.82	10.79	1.76	32.82	---	---	Peak
3	259.770	37.40	-8.60	46.00	55.82	12.52	1.93	32.87	---	---	Peak
4	358.100	31.86	-14.14	46.00	48.22	14.31	2.16	32.83	---	---	Peak
5	397.300	37.60	-8.40	46.00	52.45	15.68	2.32	32.86	117	183	Peak
6	559.700	30.67	-15.33	46.00	41.54	18.68	2.78	32.33	---	---	Peak

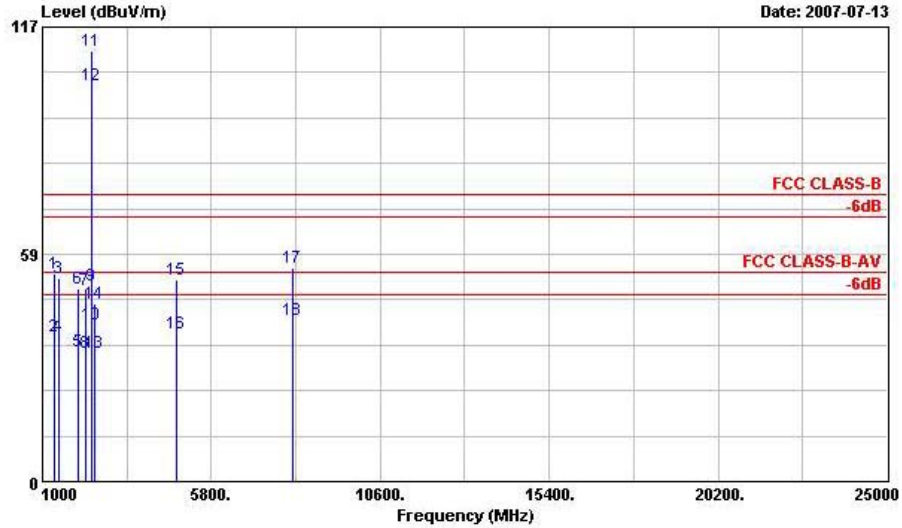

Site : 03CH04-HY  
 Condition: FCC CLASS-B 3m HF-ANT VERTICAL  
 EUT : 802.11g USB Wireless adapter  
 POWER : From Notebook  
 MODEL : FR 770310  
 MODE : 11b Tx\_Ch01;2412MHz  
 Data Rate: 11

	Freq	Level	Over	Limit	ReadAntenna	Cable	Preamp	Ant	Table	
	MHz	dBuV/m	dB	dBuV/m	dBuV	dB/m	dB	dB	cm	deg
1	1324.000	53.51	-20.49	74.00	58.21	26.65	2.60	33.95	100	0 Peak
2	1324.000	37.17	-16.83	54.00	41.87	26.65	2.60	33.95	100	277 Average
3	1454.000	52.46	-21.54	74.00	56.41	27.09	2.73	33.77	100	0 Peak
4	1454.000	37.16	-16.84	54.00	41.11	27.09	2.73	33.77	100	167 Average
5	1996.000	33.39	-20.61	54.00	32.45	31.30	3.34	33.70	100	38 Average
6	1996.000	49.58	-24.42	74.00	48.64	31.30	3.34	33.70	100	0 Peak
7	2212.000	49.16	-24.84	74.00	48.44	30.93	3.54	33.75	100	0 Peak
8	2212.000	33.27	-20.73	54.00	32.55	30.93	3.54	33.75	100	60 Average
9	2390.000	50.45	-23.55	74.00	49.91	30.59	3.74	33.78	100	0 Peak
10	2390.000	40.33	-13.67	54.00	39.79	30.59	3.74	33.78	100	60 Average
11 @	2412.000	110.70			110.16	30.56	3.76	33.78	100	0 Peak
12 @	2412.000	102.14			101.60	30.56	3.76	33.78	100	60 Average
13	2492.000	33.06	-20.94	54.00	32.62	30.40	3.84	33.80	100	60 Average
14	2492.000	45.67	-28.33	74.00	45.23	30.40	3.84	33.80	100	0 Peak
15	4821.000	52.01	-21.99	74.00	46.98	33.45	5.88	34.30	100	0 Peak
16	4821.000	38.03	-15.97	54.00	33.00	33.45	5.88	34.30	100	68 Average
17	8109.000	55.13	-18.87	74.00	42.63	39.46	6.81	33.77	100	0 Peak
18	8109.000	41.65	-12.35	54.00	29.15	39.46	6.81	33.77	100	33 Average

Remark: #11 and #12 Fundamental Signal



- Test Mode : Mode 5
- Polarization : Horizontal

■ The test that passed at minimum margin was marked by the frame in the following table.

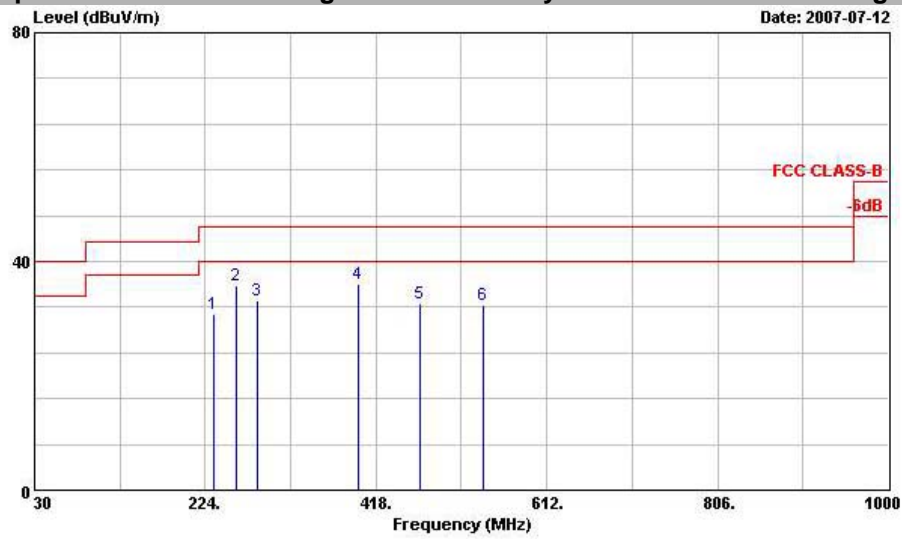

Site : 03CH04-HY  
 Condition: FCC CLASS-B 3m ANT2724 HORIZONTAL  
 EUT : 802.11g USB Wireless adapter  
 POWER : From Notebook  
 MODEL : FR 770310  
 MODE : 11b Tx\_Ch06;2437MHz  
 Data Rate: 11

	Freq	Level	Over	Limit	Read	Antenna	Cable	Preamp	Ant	Table	
	MHz	dBuV/m	Limit	Line	Level	Factor	Loss	Factor	Pos	Pos	Remark
			dB	dBuV/m	dBuV	dB/m	dB	dB	cm	deg	
1	233.580	30.78	-15.22	46.00	50.50	11.31	1.80	32.84	---	---	Peak
2	259.770	35.76	-10.24	46.00	54.18	12.52	1.93	32.87	---	---	Peak
3	283.530	33.16	-12.84	46.00	51.61	12.40	1.99	32.83	---	---	Peak
4	397.300	36.12	-9.88	46.00	50.97	15.68	2.32	32.86	100	215	Peak
5	467.300	32.65	-13.35	46.00	46.29	16.53	2.53	32.70	---	---	Peak
6	539.400	32.32	-13.68	46.00	43.89	18.07	2.73	32.37	---	---	Peak

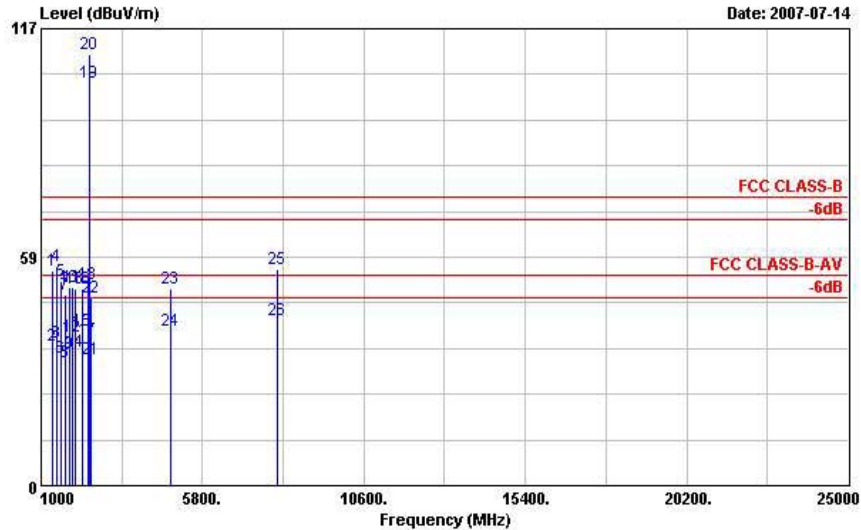

Site : 03CH04-HY  
 Condition: FCC CLASS-B 3m HF-ANT HORIZONTAL  
 EUT : 802.11g USB Wireless adapter  
 POWER : From Notebook  
 MODEL : FR 770310  
 MODE : 11b Tx\_Ch06;2437MHz  
 Data Rate: 11

	Freq	Level	Over	Limit	ReadAntenna	Cable	Preamp	Ant	Table	
	MHz	dBuV/m	Limit	Line	Level	Factor	Loss	Factor	Pos	Pos
	MHz	dBuV/m	dB	dBuV/m	dBuV	dB/m	dB	dB	cm	deg
1	1326.000	55.00	-19.00	74.00	59.70	26.65	2.60	33.95	100	0 Peak
2	1326.000	35.88	-18.12	54.00	40.58	26.65	2.60	33.95	100	113 Average
3	1454.000	36.58	-17.42	54.00	40.53	27.09	2.73	33.77	100	160 Average
4	1454.000	56.18	-17.82	74.00	60.13	27.09	2.73	33.77	100	0 Peak
5	1590.000	52.44	-21.56	74.00	55.23	28.02	2.89	33.70	100	0 Peak
6	1590.000	32.90	-21.10	54.00	35.69	28.02	2.89	33.70	100	189 Average
7	1724.000	48.87	-25.13	74.00	50.43	29.11	3.02	33.70	100	0 Peak
8	1724.000	31.69	-22.31	54.00	33.25	29.11	3.02	33.70	100	220 Average
9	1854.000	33.69	-20.31	54.00	34.14	30.07	3.18	33.70	100	182 Average
10	1854.000	50.98	-23.02	74.00	51.43	30.07	3.18	33.70	100	0 Peak
11	1916.000	50.71	-23.29	74.00	50.56	30.62	3.23	33.70	100	0 Peak
12	1916.000	38.01	-15.99	54.00	37.86	30.62	3.23	33.70	100	235 Average
13	1996.000	50.58	-23.42	74.00	49.64	31.30	3.34	33.70	100	0 Peak
14	1996.000	34.29	-19.71	54.00	33.35	31.30	3.34	33.70	100	357 Average
15	2236.000	39.70	-14.30	54.00	38.99	30.87	3.59	33.75	100	25 Average
16	2236.000	50.42	-23.58	74.00	49.71	30.87	3.59	33.75	100	0 Peak
17	2390.000	37.18	-16.82	54.00	36.64	30.59	3.74	33.78	100	130 Average
18	2390.000	51.62	-22.38	74.00	51.08	30.59	3.74	33.78	100	0 Peak
19 @	2437.000	103.04			102.54	30.49	3.79	33.79	100	130 Average
20 @	2437.000	110.31			109.81	30.49	3.79	33.79	100	0 Peak
21	2483.500	32.49	-21.51	54.00	32.02	30.43	3.84	33.80	100	130 Average
22	2483.500	48.18	-25.82	74.00	47.71	30.43	3.84	33.80	100	0 Peak
23	4869.000	50.41	-23.59	74.00	45.22	33.59	5.91	34.30	100	0 Peak
24	4869.000	39.48	-14.52	54.00	34.29	33.59	5.91	34.30	100	333 Average
25	8046.000	55.58	-18.42	74.00	42.95	39.49	6.78	33.64	100	0 Peak
26	8046.000	42.18	-11.82	54.00	29.55	39.49	6.78	33.64	100	286 Average

Remark: #19 and #20 Fundamental Signal



- Polarization : Vertical

■ The test that passed at minimum margin was marked by the frame in the following table.

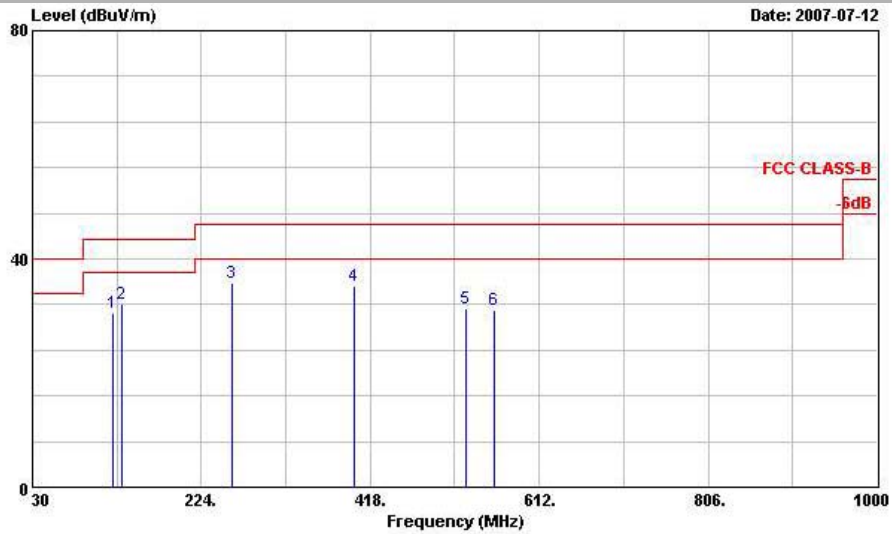

Site : 03CH04-HY  
 Condition: FCC CLASS-B 3m ANT2724 VERTICAL  
 EUT : 802.11g USB Wireless adapter  
 POWER : From Notebook  
 MODEL : FR 770310  
 MODE : 11b Tx\_Ch06;2437MHz  
 Data Rate: 11

	Freq	Level	Over	Limit	ReadAntenna	Cable	Preamp	Ant	Table	
	MHz	dBuV/m	dB	dBuV/m	dBuV	Loss	Factor	Pos	Pos	Remark
						dB	dB	cm	deg	
1	122.610	30.41	-13.09	43.50	50.79	11.20	1.26	32.85	---	--- Peak
2	133.140	32.03	-11.47	43.50	52.36	11.20	1.34	32.87	---	--- Peak
3	259.770	35.67	-10.33	46.00	54.09	12.52	1.93	32.87	100	137 Peak
4	399.400	35.19	-10.81	46.00	49.97	15.75	2.33	32.86	---	--- Peak
5	528.200	31.20	-14.80	46.00	43.20	17.75	2.70	32.45	---	--- Peak
6	559.700	30.97	-15.03	46.00	41.84	18.68	2.78	32.33	---	--- Peak



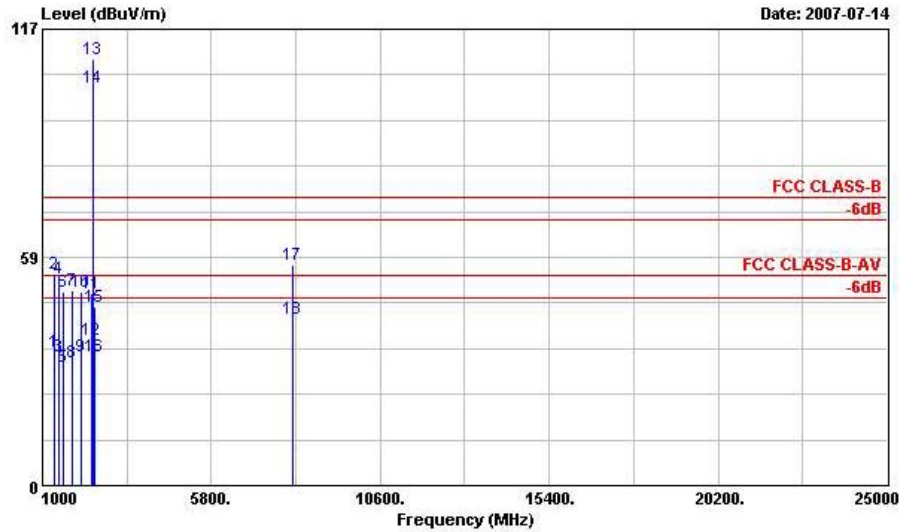

Site : 03CH04-HY  
 Condition: FCC CLASS-B 3m HF-ANT VERTICAL  
 EUT : 802.11g USB Wireless adapter  
 POWER : From Notebook  
 MODEL : FR 770310  
 MODE : 11b Tx\_Ch06;2437MHz  
 Data Rate: 11

	Freq	Level	Over	Limit	ReadAntenna	Cable	Preamp	Ant	Table	
	MHz	dBuV/m	dB	dBuV/m	dBuV	dB/m	dB	dB	cm	deg
1	1326.000	34.26	-19.74	54.00	38.96	26.65	2.60	33.95	100	278 Average
2	1326.000	54.17	-19.83	74.00	58.87	26.65	2.60	33.95	100	0 Peak
3	1454.000	33.04	-20.96	54.00	36.99	27.09	2.73	33.77	100	167 Average
4	1454.000	53.17	-20.83	74.00	57.12	27.09	2.73	33.77	100	0 Peak
5	1596.000	30.33	-23.67	54.00	33.12	28.02	2.89	33.70	100	155 Average
6	1596.000	49.48	-24.52	74.00	52.27	28.02	2.89	33.70	100	0 Peak
7	1854.000	50.19	-23.81	74.00	50.64	30.07	3.18	33.70	100	0 Peak
8	1854.000	31.49	-22.51	54.00	31.94	30.07	3.18	33.70	100	22 Average
9	2118.000	32.92	-21.08	54.00	32.10	31.08	3.46	33.73	100	60 Average
10	2118.000	49.55	-24.45	74.00	48.73	31.08	3.46	33.73	100	0 Peak
11	2390.000	49.10	-24.90	74.00	48.56	30.59	3.74	33.78	100	0 Peak
12	2390.000	37.18	-16.82	54.00	36.64	30.59	3.74	33.78	100	272 Average
13 @	2437.000	109.38			108.88	30.49	3.79	33.79	100	0 Peak
14 @	2437.000	102.08			101.58	30.49	3.79	33.79	100	272 Average
15	2483.500	45.62	-28.38	74.00	45.15	30.43	3.84	33.80	100	0 Peak
16	2483.500	33.07	-20.93	54.00	32.60	30.43	3.84	33.80	100	272 Average
17	8109.000	56.43	-17.57	74.00	43.93	39.46	6.81	33.77	100	0 Peak
18	8109.000	42.61	-11.39	54.00	30.11	39.46	6.81	33.77	100	288 Average

Remark: #13 and #14 Fundamental Signal



- Test Mode : Mode 6
- Polarization : Horizontal

■ The test that passed at minimum margin was marked by the frame in the following table.

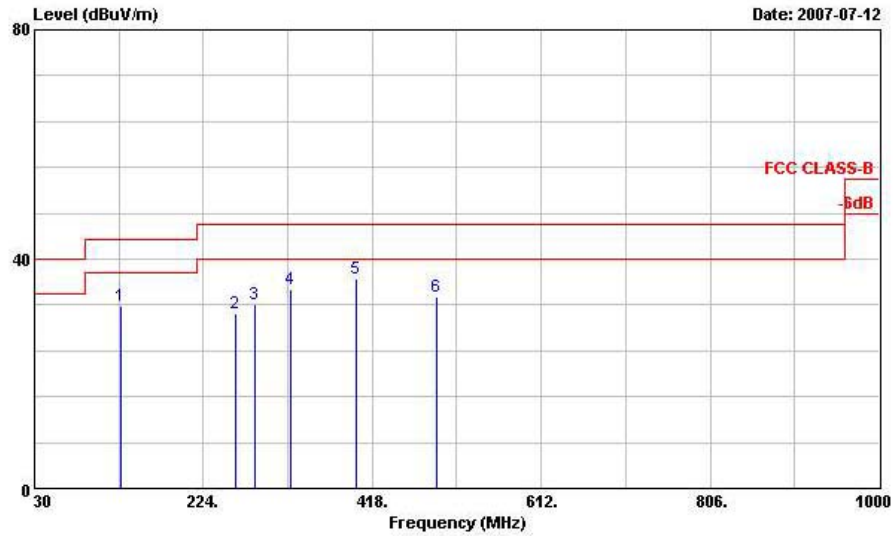

Site : 03CH04-HY  
 Condition: FCC CLASS-B 3m ANT2724 HORIZONTAL  
 EUT : 802.11g USB Wireless adapter  
 POWER : From Notebook  
 MODEL : FR 770310  
 MODE : 11b Tx\_Ch11;2462MHz  
 Data Rate: 11

	Freq	Level	Over	Limit	Read	Antenna	Cable	Preamp	Ant	Table	
	MHz	dBuV/m	dB	dBuV/m	Level	Factor	Loss	Factor	Pos	Pos	Remark
					dBuV	dB/m	dB	dB	cm	deg	
1	129.900	31.74	-11.76	43.50	51.83	11.46	1.32	32.87	---	---	Peak
2	260.580	30.42	-15.58	46.00	48.84	12.51	1.93	32.86	---	---	Peak
3	283.530	32.21	-13.79	46.00	50.66	12.40	1.99	32.83	---	---	Peak
4	323.800	34.68	-11.32	46.00	52.28	13.14	2.08	32.82	---	---	Peak
5	399.400	36.53	-9.47	46.00	51.31	15.75	2.33	32.86	100	217	Peak
6	491.800	33.44	-12.56	46.00	46.70	16.81	2.58	32.66	---	---	Peak

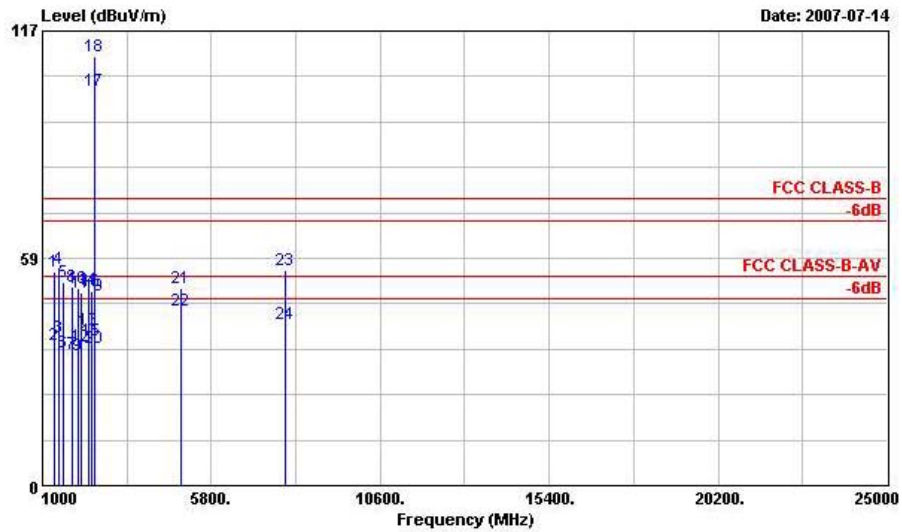

Site : 03CH04-HY  
 Condition: FCC CLASS-B 3m HF-ANT HORIZONTAL  
 EUT : 802.11g USB Wireless adapter  
 POWER : From Notebook  
 MODEL : FR 770310  
 MODE : 11b Tx\_Ch11;2462MHz  
 Data Rate: 11

	Freq	Level	Over Limit	Limit Line	ReadAntenna	Cable	Preamp	Ant	Table	Remark
	MHz	dBuV/m	dB	dBuV/m	dBuV	dB/m	dB	dB	cm	deg
1	1324.000	55.17	-18.83	74.00	59.87	26.65	2.60	33.95	100	0 Peak
2	1324.000	36.32	-17.68	54.00	41.02	26.65	2.60	33.95	100	113 Average
3	1454.000	38.13	-15.87	54.00	42.08	27.09	2.73	33.77	100	156 Average
4	1454.000	55.91	-18.09	74.00	59.86	27.09	2.73	33.77	100	0 Peak
5	1596.000	52.47	-21.53	74.00	55.26	28.02	2.89	33.70	100	0 Peak
6	1596.000	34.12	-19.88	54.00	36.91	28.02	2.89	33.70	100	155 Average
7	1854.000	33.70	-20.30	54.00	34.15	30.07	3.18	33.70	100	210 Average
8	1854.000	51.16	-22.84	74.00	51.61	30.07	3.18	33.70	100	0 Peak
9	1996.000	33.53	-20.47	54.00	32.59	31.30	3.34	33.70	100	357 Average
10	1996.000	50.88	-23.12	74.00	49.94	31.30	3.34	33.70	100	0 Peak
11	2118.000	49.61	-24.39	74.00	48.79	31.08	3.46	33.73	100	0 Peak
12	2118.000	35.78	-18.22	54.00	34.96	31.08	3.46	33.73	100	237 Average
13	2302.000	40.16	-13.84	54.00	39.54	30.74	3.64	33.76	100	27 Average
14	2302.000	50.51	-23.49	74.00	49.89	30.74	3.64	33.76	100	0 Peak
15	2390.000	37.19	-16.81	54.00	36.65	30.59	3.74	33.78	100	357 Average
16	2390.000	50.07	-23.93	74.00	49.53	30.59	3.74	33.78	100	0 Peak
17 @	2462.000	101.52			101.04	30.46	3.81	33.79	100	357 Average
18 @	2462.000	110.36			109.88	30.46	3.81	33.79	100	0 Peak
19	2483.500	48.93	-25.07	74.00	48.46	30.43	3.84	33.80	100	0 Peak
20	2483.500	35.36	-18.64	54.00	34.89	30.43	3.84	33.80	100	357 Average
21	4926.000	50.97	-23.03	74.00	45.60	33.72	5.95	34.30	100	0 Peak
22 @	4926.000	45.07	-8.93	54.00	39.70	33.72	5.95	34.30	100	253 Average
23	7917.000	55.56	-18.44	74.00	43.04	39.43	6.72	33.64	100	0 Peak
24	7917.000	41.45	-12.55	54.00	28.93	39.43	6.72	33.64	100	255 Average

Remark: #17 and #18 Fundamental Signal