

***MEASUREMENT REPORT***  
***of***  
***WIRELESS LAN USB ADAPTER***

**Applicant** : Universal Scientific Industrial Co., Ltd.  
**Model No.** : LC\_USB  
**EUT** : USB Client  
**FCC ID** : IXMUSB114401  
**Report No.** : U1315771

Tested by :

***Training Research Co., Ltd.***

**TEL : 886-2-26935155      FAX : 886-2-26934440**  
255, Nanyang Street, Shijr, Taipei Hsien 221, Taiwan, R.O.C.

# CERTIFICATION

**We here by verify that:**

The test data, data evaluation, test procedures and equipment configurations shown in this report were made mainly in accordance with the procedures given in ANSI C63.4 (1992) as a reference. All test were conducted by *Training Research Co., Ltd.*, 255, Nanyang Street, Shijr, Taipei Hsien 221, Taiwan, R.O.C. Also, we attest to the accuracy of each.

We further submit that the energy emitted by the sample EUT tested as described in the report is in compliance with the technical requirements set forth in the FCC Rules Part 15 Subpart C Section 15.247.

**Applicant** : Universal Scientific Industrial Co., Ltd.

**Model No.** : LC\_USB

**EUT** : USB Client

**FCC ID** : IXMUSB114401

**Report No.** : U1315771

**Test Date** : September 12, 2002

Prepared by:

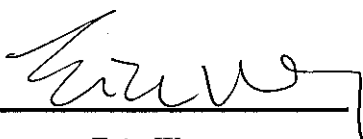

*Eric Wong*

Approved by:

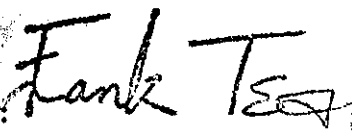

*Frank Tsai*

Tested by :

***Training Research Co., Ltd.***

TEL: 886-2-26935155

FAX: 886-2-26934440

255, Nanyang Street, Shijr, Taipei Hsien 221, Taiwan, R.O.C.

---

Report No.: U1315771

Training Research Co., Ltd., TEL: 886-2-26935155, Fax: 886-2-26934440

***Tables of Contents***

**I. GENERAL** ..... 5

    1.1 Introduction ..... 5

    1.2 Description of EUT ..... 5

    1.3 Description of Support Equipment ..... 6

    1.4 Configuration of System Under Test ..... 7

    1.5 Verify the Frequency and Channel ..... 8

    1.6 Test Procedure ..... 9

    1.7 Location of the Test Site ..... 9

    1.8 General Test Condition ..... 9

**II. Section 15.101(a) : Equipment Authorization of Unintentional Radiators** ..... 10

**III. Section 15.203 : Antenna Requirement**..... 11

**IV. Section 15.207 : Power Line Conducted Emissions for AC Powered Units** ..... 12

    4.1 Test Condition & Setup ..... 12

    4.2 List of Test Instruments ..... 12

    4.3 Test Configuration ..... 13

    4.4 Test Result of Conducted Emissions ..... 14

**V. Section 15.247(a) : Technical Description of the EUT** ..... 17

**VI. Section 15.247(a)(2) : Bandwidth for Direct Sequence System** ..... 18

    6.1 Test Condition & Setup ..... 18

    6.2 Test Instruments Configuration ..... 18

    6.3 List of Test Instruments ..... 18

    6.4 Test Result of Bandwidth ..... 19

**VII. Section 15.247(b) : Power Output** ..... 23

    7.1 Test Condition & Setup ..... 23

    7.2 List of Test Instruments ..... 23

    7.3 Test Result ..... 24

**VIII. Section 15.247(c) : Spurious Emissions (Radiated)** ..... 25

    8.1 Test Condition & Setup ..... 25

    8.2 List of Test Instruments ..... 26

    8.3 Test Instruments Configuration ..... 27

    8.4 Test Result of Spurious Radiated Emissions ..... 28

    8.5 Test Result of Band-edge Compliance ..... 35

**IX. Section 15.247(d) : Power Spectral Density** ..... 38

    9.1 Test Condition & Setup ..... 38

    9.2 Test Instruments Configuration ..... 38

    9.3 List of Test Instruments ..... 38

9.4 Test Result of Power Spectral Density ..... 39  
**Appendix A: Set Up Procedure** ..... 43

## **. GENERAL**

### **1.1 Introduction**

The following measurement report is submitted on behalf of Applicant in support of a wireless access CompactFlash card certification in accordance with Part 2 Subpart J and Part 15 Subpart A and C of the Commission's Rules and Regulations.

### **1.2 Description of EUT**

**EUT** : USB Client  
**Model No.** : LC\_USB  
**Granted FCC ID** : IXMUSB114401  
**Frequency Range** : 2.412 GHz ~ 2.462GHz  
**Support Channel** : 11 Channel  
**Modulation Skill** : DBPSK, DQPSK, CCK  
**Interface** : USB  
**Power Type** : By USB port of the client's device  
**Applicant** : Universal Scientific Industrial Co., Ltd.  
135, Lane 351, Taiping Rd., Sect.1, Tsao Tuen, Nantou 542,  
Taiwan, R.O.C.

### 1.3 Description of Support Equipment

In order to construct the minimum testing, following equipment were used as the support units.

**Notebook** : **IBM COMPUTER INC.**

Type No. : 08N1180

Serial No. : 11SO8K6451ZFX0820AJOLB

FCC ID : DoC Approved

**AC Adaptor** : **ASTEC INC. (China)**

Model No. : 02K6654

Serial No. : 11SO2K6654Z1Z0Z40325LE

FCC ID : DoC Approved

Power Core : Non-shielded, Plastic hoods, with ferrite bead

Power type : 100 ~ 240VAC, 50 ~ 60Hz, 1.2A-0.5A / 16VDC, 4.5A

#### 1.4 Configuration of System Under Test

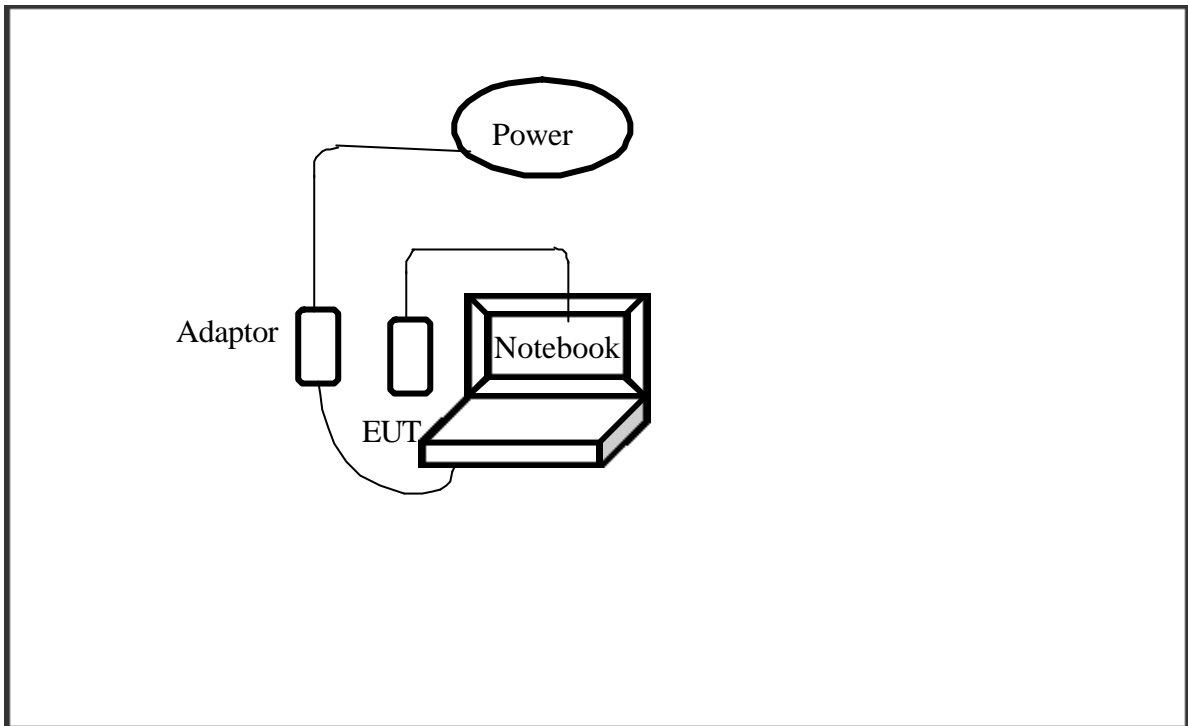

The tests below are carried out the EUT transmitter set at high power in TDD mode. The EUT was setup by connecting the USB port of the notebook computer. The EUT is needed to force selection of output power level and channel number.

The setting up procedure was recorded in <Appendix A>.

**1.5 Verify the Frequency and Channel**

Channel	Frequency (GHz)
1	2.412
2	2.417
3	2.422
4	2.427
5	2.432
6	2.437
7	2.442
8	2.447
9	2.452
10	2.457
11	2.462

Note:

1. This is for confirming that all frequencies are in 2.412GHz to 2.462GHz.
2. Section 15.31(m): Measurements on intentional radiators or receivers shall be performed at three frequencies for operating frequency range over 10 MHz.  
(The locations of these frequencies one near the top, one near the middle and one near the bottom.)
3. After test, the EUT operating frequencies are in 2.412GHz to 2.462GHz. So all the items as followed in testing report are need to test these three frequencies:  
Top: Channel – 1; Middle: Channel – 6; Bottom: Channel – 11.



## **1.6 Test Procedure**

All measurements contained in this report were performed mainly according to the techniques described in ANSI C63.4 (1992) and the pre-setup was written on Appendix A, the detail setup was written on each test item.

## **1.7 Location of the Test Site**

The radiated emissions measurements required by the rules were performed on the **three-meter, Anechoic Chamber (Registration Number: 93906)** maintained by *Training Research Co., Ltd.* 1F, No. 255, Nanyang Street, Shijr, Taipei Hsien 221, Taiwan, R.O.C. Complete description and measurement data have been placed on file with the commission. The conducted power line emissions tests and other test items were performed in a anechoic chamber also located at Training Research Co., Ltd.

No. 255, Nanyang Street, Shijr, Taipei Hsien 221, Taiwan, R.O.C. *Training Research Co., Ltd.* is listed by the FCC as a facility available to do measurement work for others on a contract basis.

## **1.8 General Test Condition**

The conditions under which the EUT operates were varied to determine their effect on the equipment's emission characteristics. The final configuration of the test system and the mode of operation used during these tests were chosen as that which produced the highest emission levels. However, only those conditions, which the EUT was considered likely to encounter in normal use were investigated.

In test, they were set in high power and continuously transmitting mode that controlled by notebook computer. The ch01, ch06 and ch11 of EUT were all tested. The setting up procedure is recorded on Appendix A.

## **II. Section 15.101(a): Equipment authorization of unintentional radiators**

The EUT equipped with a USB interface and should be operated with the computer, was categorized to *Class B personal computers and peripherals* as cannot be operated stand-alone. The authorization requires Certification and the items required such as Sect.15.107 (Conducted limits) and Sect.15.109 (Radiated emission limits) is same as Sect.15.207 and 15.247(C) we' d performed respectively. We dropped this part, as the result will be repeated as the part we mentioned above.

### **III. Section 15.203: Antenna requirement**

The EUT has the integrated antennas installed in the housing of the EUT. There's no external antenna connector employed for any other extra antenna. In addition, there's no modification to be done unless by using the tools to break the housing construction. The antenna requirement stated in Sect.15.203 is inapplicable to this EUT.

**IV. Section 15.207: Power Line Conducted Emissions for AC Powered Units**

**4.1 Test Condition & Setup**

The power line conducted emission measurements were performed in an anechoic chamber. The EUT was assembled on a wooden table, which is 80 centimeters high, was placed 40 centimeters from the back-wall and at least 1 meter from the sidewall.

Power was fed to the EUT from the public utility power grid through a line filter and Line Impedance Stabilization Networks (LISNs). The LISN housing, measuring instrumentation case, ground plane, etc., were electrically bonded together at the same RF potential. The Spectrum analyzer (or EMI receiver) was connected to the AC line through an isolation transformer. The 50-ohm output of the LISN was connected to the spectrum analyzer directly. Conducted emission levels were in the CISPER quasi-peak detection mode. The analyzer's 6 dB bandwidth was set to 9 KHz. No post-detector video filter was used.

The spectrum was scanned from 450 KHz to 30 MHz. The physical arrangement of the test system and associated cabling was varied (within the scope of arrangements likely to be encountered in actual use) to determine the effect on the unit's emanations in amplitude and frequency. All spurious emission frequencies were observed. The highest emission amplitudes relative to the appropriate limit were measured and have been recorded in paragraph 2.4.

There is a test condition apply in this test item, the test procedure description as the following:

1. EUT transmit only:

Using the USB port of the notebook computer and software to control the EUT. Then making access to the mode of continuous transmission and setting the testing channel. Three channels were tested, one in the top (CH01), one in the middle (CH06) and the other in bottom (CH11).

The setting up procedure is recorded on <Appendix A>.

**4.2 List of Test Instruments**

<u>Instrument Name</u>	<u>Model No.</u>	<u>Brand</u>	<u>Serial No.</u>	<u>Last time</u>	<u>Next time</u>
EMI Receiver	8546A	H P	3520A00242	06/29/02	06/29/03
RF Filter Section	85460A	H P	3448A00217	06/29/02	06/29/03
LISN (EUT)	LISN-01	TRC	9912-03,04	12/09/01	12/09/02
LISN (Support E.)	LISN-01	TRC	9912-05	01/04/02	01/04/03
Switch/Control Unit (< 30MHz)	3488A	HP	N/A	11/20/01	11/20/02
Auto Switch Box (< 30MHz)	ASB-01	TRC	9904-01	11/20/01	11/20/02

4.3 Test configuration

*Conducted Emissions Test Placement*

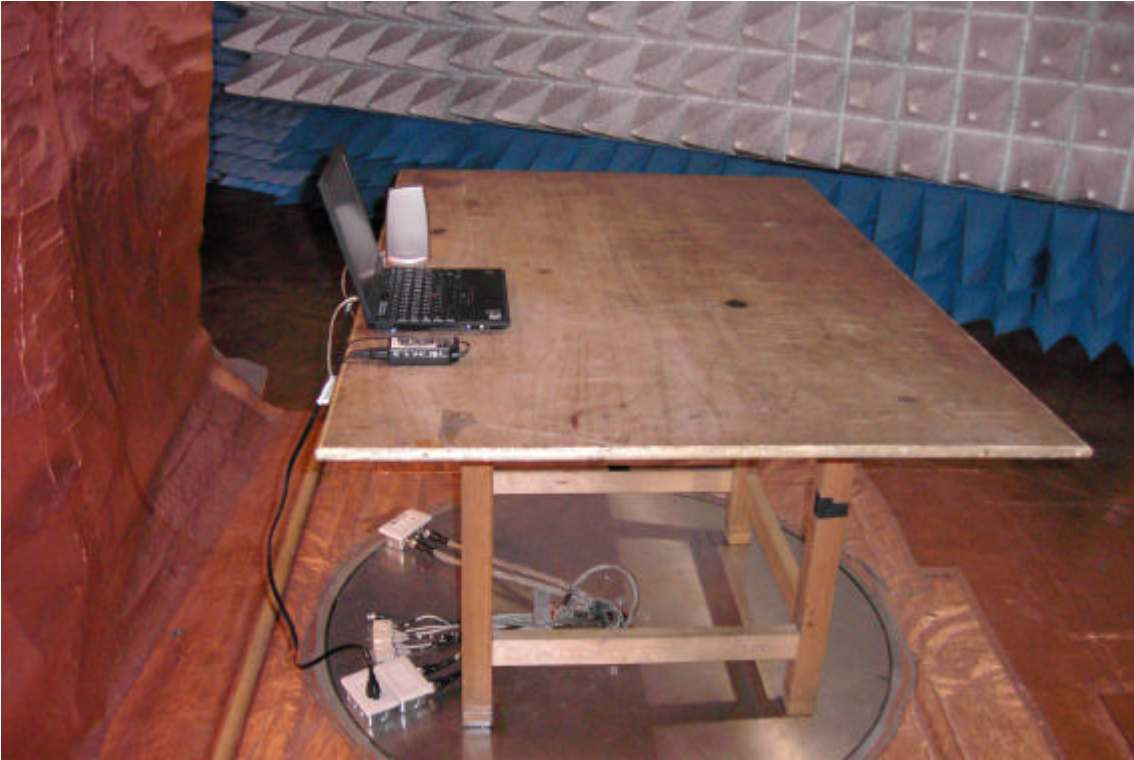
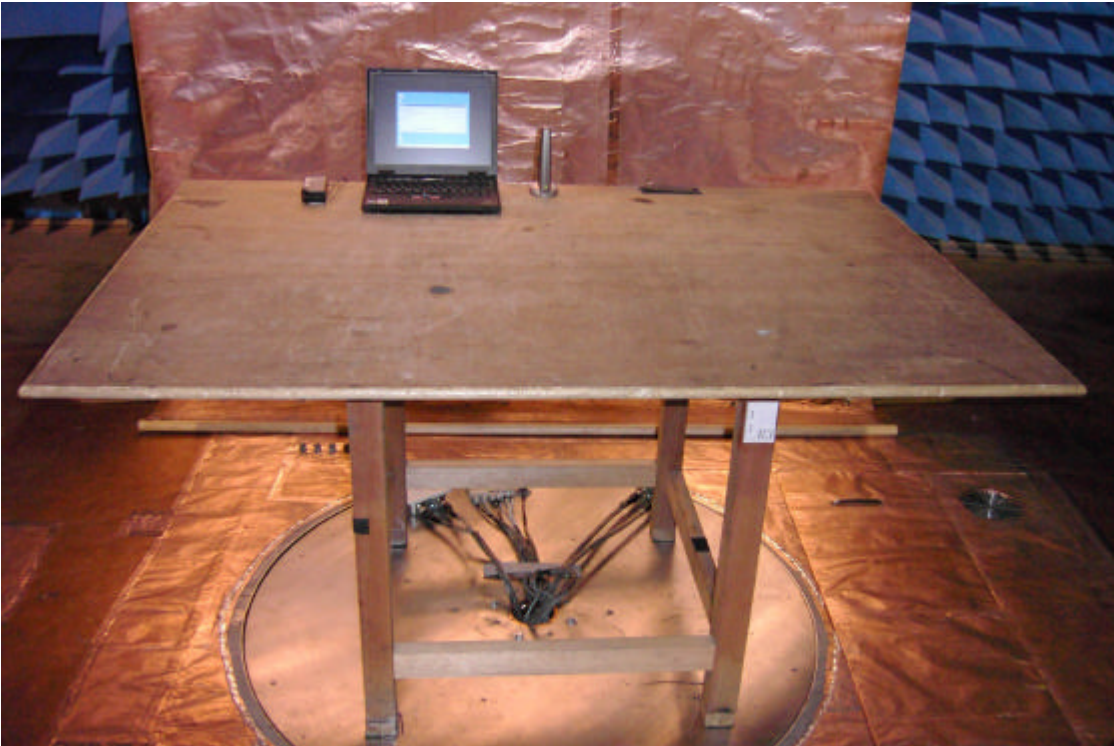

**4.4 Test Result of Conducted Emissions**

**EUT transmit only**

The following table shows a summary of the highest emissions of power line conducted emissions on the LIVE and NETURAL conductors of the EUT power cord.

**Table 1 Power Line Conducted Emissions (Channel 1, Transmitter Mode)**

<i>Power Connected Emissions</i>				<i>FCC Class B</i>	
<i>Conductor</i>	<i>Frequency (KHz)</i>	<i>Peak Amplitude (dB μ V)</i>	<i>QP Amplitude (dB μ V)</i>	<i>Limit (dB μ V)</i>	<i>Margin (dB)</i>
Line 1	490.000	41.12	---	48.00	-6.88
	590.000	37.66	---	48.00	-10.34
	750.000	38.38	---	48.00	-9.62
	880.000	38.74	---	48.00	-9.26
	980.000	41.21	---	48.00	-6.79
	1250.000	40.20	---	48.00	-7.80
	1360.000	40.70	---	48.00	-7.30
	1730.000	40.81	---	48.00	-7.19
	2140.000	38.90	---	48.00	-9.10
	2550.000	37.84	---	48.00	-10.16
Line 2	490.000	41.00	---	48.00	-7.00
	880.000	38.67	---	48.00	-9.33
	980.000	40.84	---	48.00	-7.16
	1270.000	39.82	---	48.00	-8.18
	1370.000	40.37	---	48.00	-7.63
	1630.000	38.81	---	48.00	-9.19
	1770.000	39.78	---	48.00	-8.22
	2140.000	38.48	---	48.00	-9.52
	2500.000	37.14	---	48.00	-10.86
	3250.000	34.27	---	48.00	-13.73

NOTE:

1. Margin = Peak Amplitude - Limit
2. A "+" sign in the margin column means the emission is OVER the Class B Limit and "-" sign of means UNDER the Class B limit

**Table 2 Power Line Conducted Emissions (Channel 6, Transmitter Mode)**

<i>Power Connected Emissions</i>				<i>FCC Class B</i>	
<i>Conductor</i>	<i>Frequency (KHz)</i>	<i>Peak Amplitude (dB μ V)</i>	<i>QP Amplitude (dB μ V)</i>	<i>Limit (dB μ V)</i>	<i>Margin (dB)</i>
Line 1	500.000	40.65	---	48.00	-7.35
	590.000	38.07	---	48.00	-9.93
	690.000	37.91	---	48.00	-10.09
	890.000	39.06	---	48.00	-8.94
	980.000	40.24	---	48.00	-7.76
	1250.000	40.79	---	48.00	-7.21
	1390.000	41.38	---	48.00	-6.62
	1750.000	41.70	---	48.00	-6.30
	2080.000	39.28	---	48.00	-8.72
	2580.000	38.62	---	48.00	-9.38
Line 2	490.000	41.07	---	48.00	-6.93
	600.000	38.19	---	48.00	-9.81
	690.000	37.55	---	48.00	-10.45
	980.000	40.29	---	48.00	-7.71
	1090.000	39.16	---	48.00	-8.84
	1370.000	39.80	---	48.00	-8.20
	1770.000	39.02	---	48.00	-8.98
	2030.000	38.50	---	48.00	-9.50
	2550.000	37.05	---	48.00	-10.95
	2830.000	35.53	---	48.00	-12.47

**\*The reading amplitudes are all under limit.**

**Table 3 Power Line Conducted Emissions (Channel 11, Transmitter Mode)**

<i>Power Connected Emissions</i>				<i>FCC Class B</i>	
<i>Conductor</i>	<i>Frequency (KHz)</i>	<i>Peak Amplitude (dB μ V)</i>	<i>QP Amplitude (dB μ V)</i>	<i>Limit (dB μ V)</i>	<i>Margin (dB)</i>
Line 1	490.000	40.81	---	48.00	-7.19
	590.000	39.30	---	48.00	-8.70
	770.000	38.05	---	48.00	-9.95
	980.000	40.74	---	48.00	-7.26
	1270.000	40.36	---	48.00	-7.64
	1370.000	41.21	---	48.00	-6.79
	1670.000	39.89	---	48.00	-8.11
	1770.000	42.02	---	48.00	-5.98
	2050.000	38.85	---	48.00	-9.15
	2140.000	40.03	---	48.00	-7.97
Line 2	490.000	40.93	---	48.00	-7.07
	590.000	37.76	---	48.00	-10.24
	770.000	37.00	---	48.00	-11.00
	890.000	39.25	---	48.00	-8.75
	980.000	40.06	---	48.00	-7.94
	1270.000	39.82	---	48.00	-8.18
	1370.000	40.88	---	48.00	-7.12
	1670.000	39.21	---	48.00	-8.79
	1770.000	39.53	---	48.00	-8.47
	2050.000	38.05	---	48.00	-9.95

**\*The reading amplitudes are all under limit.**



## **V. Section 15.247 (a): Technical description of the EUT**

Based on the Section 2.1, *Direct Sequence System* is a spread spectrum system in which the carrier has been modulated by a high speed spreading code and an information data stream. The high speed code sequence dominates the “modulating function” and is the direct cause of the wide spreading of the transmitted signal. In the Exhibit H, operational description demonstrates the operation principles of the Baseband processor employed by the EUT, shows that which is a complete DSSS baseband processor and meets the definition of the Direct sequence spread spectrum system.

**VI. Section 15.247(a)(2): Bandwidth for Direct Sequence System**

**6.1 Test Condition & Setup**

The transmitter bandwidth measurements were performed by the contact manner. The EUT was set to transmit continuously, also various channels were investigated to find the maximum occupied bandwidth.. The output of the EUT was connected to the spectrum analyzer. The bandwidth of the fundamental frequency is observed by the spectrum analyzer with 100kHz RBW and 100kHz VBW.

**6.2 Test Instruments Configuration**

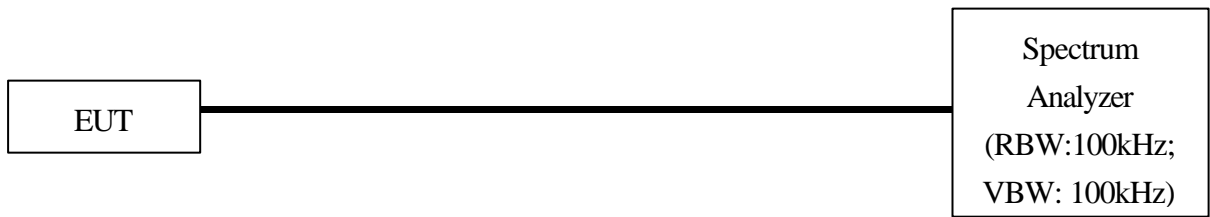

Test Configuration of Bandwidth for Direct Sequence System

*P.S.: Notebook computer to control the EUT at maximal power output and channel Number and set antenna kit*

**5.3 List of Test Instruments**

Instrument Name	Model No.	Brand	Serial No.	Last time	Next time
Spectrum Analyzer	8592A	H P	3003AD1401	01/02/02	01/01/03

#### **6.4 Test Result of Bandwidth**

##### **Bandwidth of Channel 1**

Bandwidth : 10.35 MHz  
The min. 6 dB BW at least : 500 KHz

##### **Bandwidth of Channel 6**

Bandwidth : 10.55 MHz  
The min. 6 dB BW at least : 500 KHz

##### **Bandwidth of Channel 11**

Bandwidth : 10.45 MHz  
The min. 6 dB BW at least : 500 KHz

Note:

1. The data in the above table are summarizing the following attachment spectrum analyzer hard copy. According to the guidance, we'd made the measurement with the spectrum analyzer's resolution bandwidth ( $RBW$ )= $100kHz$  and set the  $span \gg RBW$ . The results show the measured 6dB bandwidth comply with the minimum 500kHz requirement.
2. The attachments show these on the following pages.

Bandwidth of Channel 1: 10.35 MHz

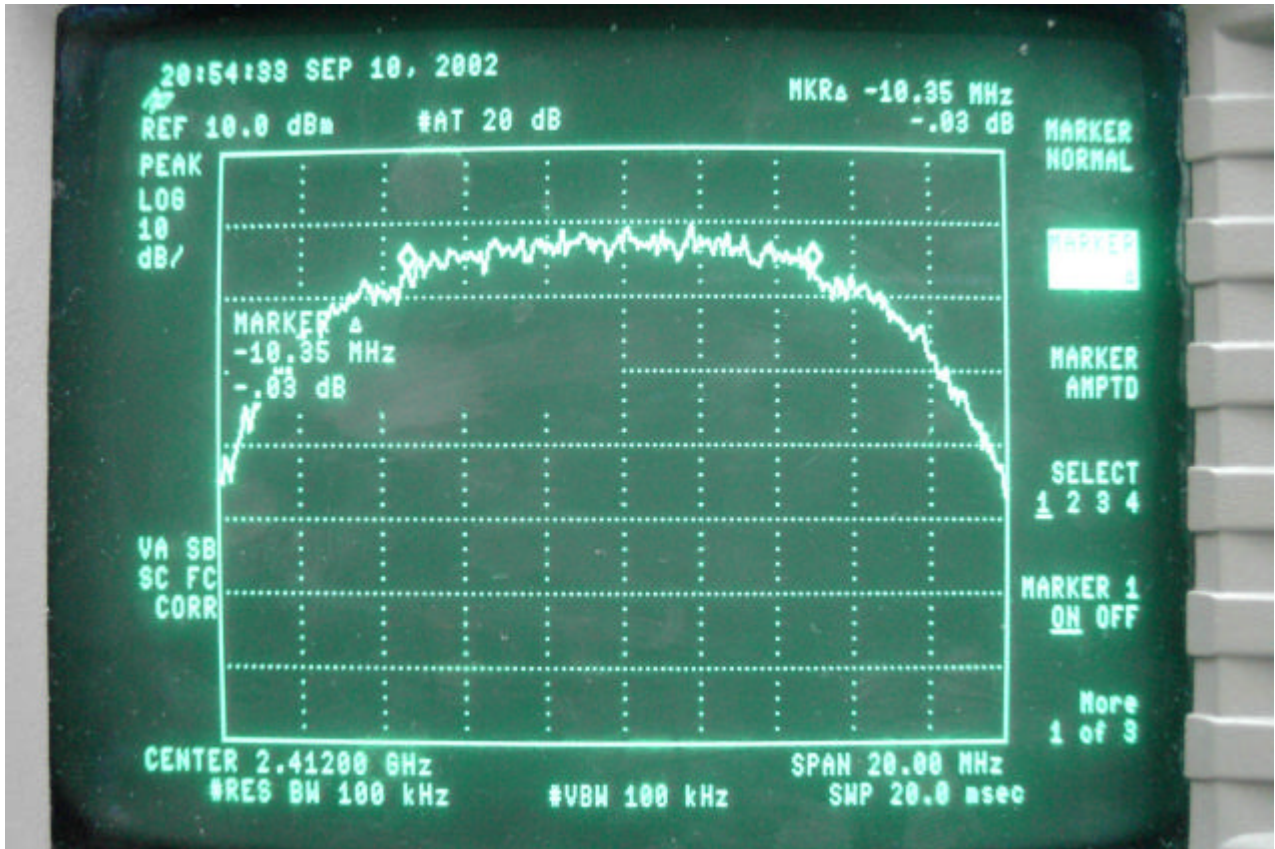

Bandwidth of Channel 6: 10.55 MHz

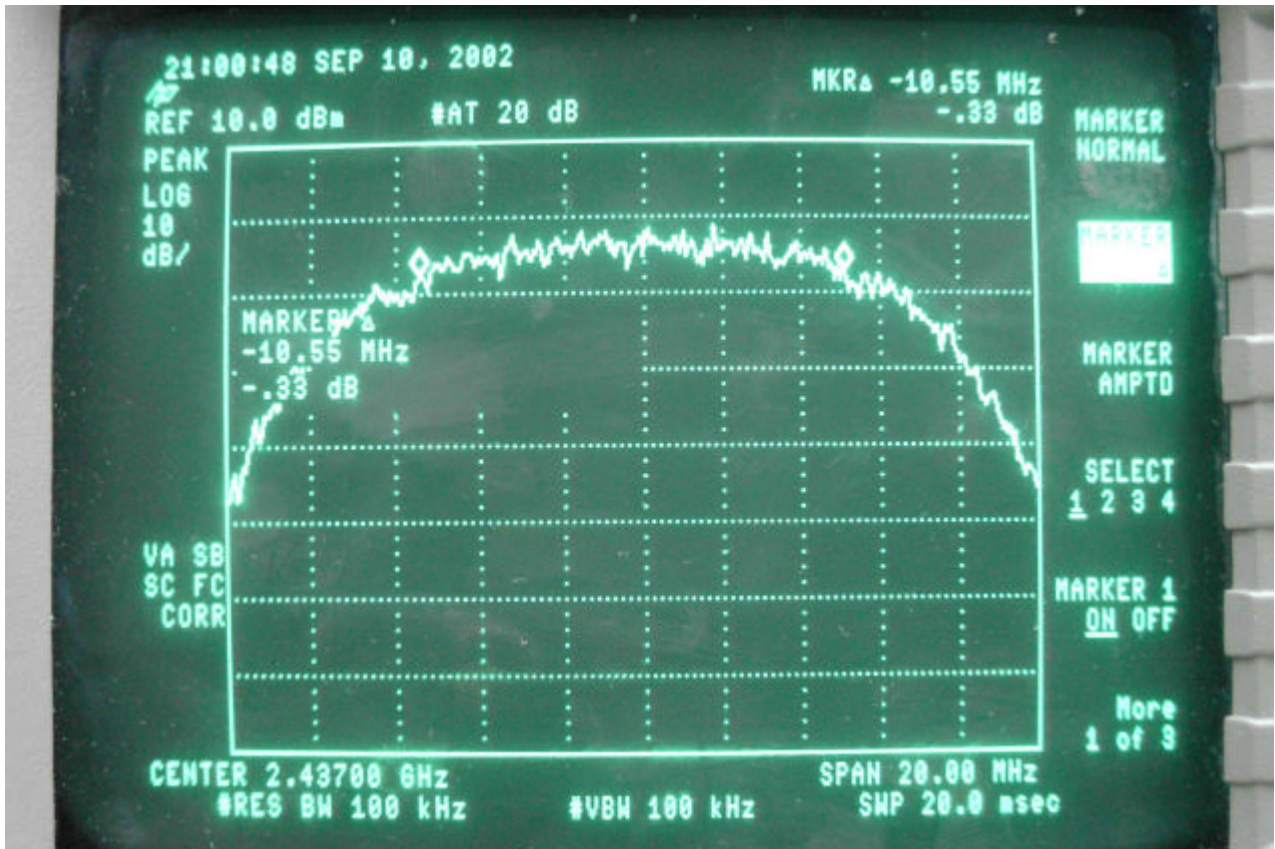

Bandwidth of Channel 11: 10.45 MHz

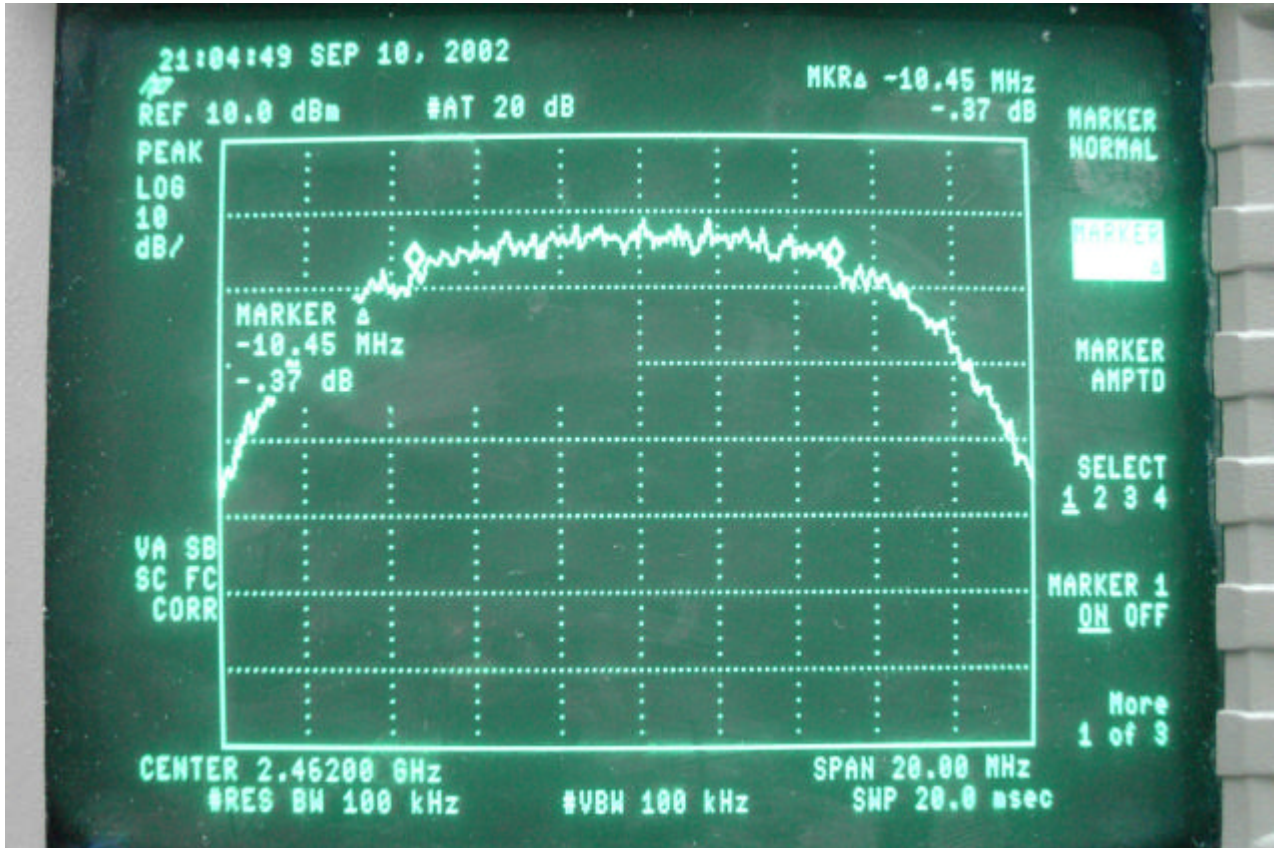

**VII. Section 15.247(b): Power Output**

**7.1 Test Condition & Setup**

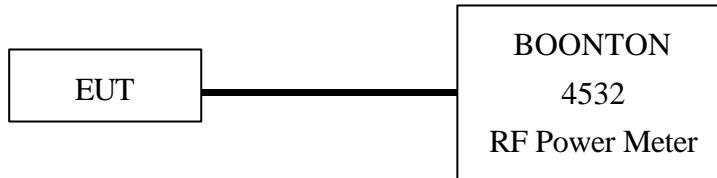

1. The output of the transmitter is connected to the BOONTON RF Power Meter.
2. The calibration is performed before every tests. The values of the output power of the EUT will shown in the dBm directly are the transmitter output peak power. Recording as follows.

**7.2 List of Test Instruments**

Instrument Name	Model No.	Brand	Serial No.	Last Cali.	Due On
RF Power Meter	4532	BOONTON	117501	02/03/21	03/03/21

**7.3 Test Result**

**Formula:**  
 Signal generator + |Cable loss| = Output peak power

Channel	Signal Generator	Cable Loss	Limit	Output peak power	
	dBm	dBm	(DTS)	dBm	mW
CH1	14.75	0.70	100mW	15.45	35.08
CH6	13.58	0.70	100mW	14.28	26.79
CH11	12.58	0.70	100mW	13.28	21.28

Note:

The limit is varying according to the equipment class, listed below:

1. Digital Transmission System (DTS): 100mW
2. Spread Spectrum Transmitter (DSS): 1W



## **VIII. Section 15.247 (C): Spurious Emissions (Radiated)**

### **8.1 Test Condition & Setup**

We'd performed the test by the *radiated emission* skill: The EUT was placed in an anechoic chamber, and set the EUT transmitting continuously and scanned at 3-meter distance to determine its emission characteristics. The physical arrangement of the EUT was varied (within the scope of arrangements likely to be encountered in actual use) to determine the effect on the unit's emanations in amplitude, directivity, and frequency. The exact system configuration, which produced the highest emissions was noted so it could be reproduced later during the final tests. For the measurement above 1GHz, according to the guidance we'd set the spectrum analyzer's 6dB bandwidth RBW to 1MHz.

This was done to ensure that the final measurements would demonstrate the worst-case interference potential of the EUT.

Final radiation measurements were made on a three-meter, anechoic chamber. The EUT system was placed on a nonconductive turntable, which is 0.8 meters height, top surface 1.0 x 1.5 meter.

The spectrum was examined from 30 MHz to 1000 MHz using an Hewlett Packard 85460A EMI Receiver, Schaffner whole range Bi-Log antenna (Model No.: CBL6141A) is used to measure frequency from 30 MHz to 1GHz. The final test is used the spectrum HP 85460A and spectrum was examined from 1GHz to 18GHz using an Hewlett Packard 8564E Spectrum Analyzer, EMCO Horn Antenna (Model 3115) for 1G ~ 18GHz.

At each frequency, the EUT was rotated 360 degrees, and the antenna was raised and lowered from one to four meters to find the maximum emission levels. Measurements were taken using both horizontal and vertical antenna polarization.

Appropriate preamplifiers were used for improving sensitivity and precautions were taken to avoid overloading or desensitizing the spectrum analyzer. There are two spectrum analyzers use on this testing, HP 85460A for frequency 30MHz to 1000MHz, and 8564E for frequency 1GHz to 18GHz. No post-detector video filters were used in the test. The spectrum analyzer's 6dB bandwidth was set to 120KHz (spectrum was examined from 30 MHz to 1000 MHz), the spectrum analyzer's 6 dB bandwidth was set to 1 MHz (spectrum was examined from 1GHz to 18GHz) and the analyzer was operated in the maximum hold mode. There is a test condition apply in this test item, the test procedure description as the following:

Using the PCMCIA interface of Notebook computer and software to control the EUT through Ethernet hub. Then making access to the mode of continuous transmission. Three channels were tested, one in the top (CH01), one in the middle (CH06) and the other in bottom (CH11).

With the transmitter operating from a AC source and using the internal of EUT, radiates spurious emissions falling within the restricted bands of 15.209 were measured at operating frequencies corresponding to upper, middle and bottom channels in the 2400 ~ 2483.5 MHz band.

The actual field intensity in decibels referenced to 1 microvolt per meter (dB $\mu$ V/m) is determined by algebraically adding the measured reading in dB $\mu$ V, the antenna factor (dB), and cable loss (dB) at the appropriate frequency. Since the EUT was set to transmit continuously, no *duty cycle* is present.

**For frequency between 30MHz to 1000MHz**

$$F_{Ia} \text{ (dB}\mu\text{V/m)} = F_{Ir} \text{ (dB}\mu\text{V)} - \text{Correction Factors}$$

F<sub>Ia</sub> : Actual Field Intensity

F<sub>Ir</sub> : Reading of the Field Intensity

$$\text{Correction Factors} = \text{Antenna Factor} + \text{Cable Loss} - \text{Amplifier Gain}$$

**For frequency between 1 GHz to 18 GHz**

$$F_{Ia} \text{ (dB}\mu\text{V/m)} = F_{Ir} \text{ (dB}\mu\text{V)} + \text{Correction Factor}$$

F<sub>Ia</sub> : Actual Field Intensity

F<sub>Ir</sub> : Reading of the Field Intensity

$$\text{Correction Factors} = \text{Antenna Factor} + \text{Cable Loss} - \text{Amplifier Gain}$$

The setting up procedure is recorded on Appendix A.

**8.2 List of Test Instruments**

<u>Instrument Name</u>	<u>Model No.</u>	<u>Brand</u>	<u>Serial No.</u>	<u>Last</u>	<u>Due</u>
EMI Receiver	8546A	H P	3520A00242	06/29/02	06/29/03
RF Filter Section	85460A	H P	3448A00217	06/29/02	06/29/03
Bi-log Antenna	CBL6141A	Schaffner	4206	03/09/02	03/09/03
Switch/Control Unit (> 30MHz)	3488A	HP	N/A	11/20/01	11/20/02
Auto Switch Box (> 30MHz)	ASB-01	TRC	9904-01	11/20/01	11/20/02
Spectrum Analyzer	8564E	HP	US36433002	08/01/02	08/01/03
Microwave Preamplifier	83051A	HP	3232A00347	08/01/02	08/01/03
Horn Antenna	3115	EMCO	9704 – 5178	08/01/02	08/01/03
Anechoic Chamber (cable calibrated together)				05/20/02	05/20/03

### 8.3 Test Instruments Configuration



Front View of the Test Configuration



Rear View of the Test Configuration

**The test configuration for frequency between 1GHz to 18GHz is same as above.**

**8.4 Test Result of Spurious Radiated Emissions**

**EUT's transmit only**

The highest peak values of radiated emissions from the EUT at various antenna heights, antenna polarizations, EUT orientation, etc. are recorded on the following.

**FCC ID** : IXMUSB114401

**EUT** : LC\_USB

Test Conditions:            Testing room : Temperature : 26 ° C    Humidity : 67 % RH  
                                  Testing site : Temperature : 28 ° C    Humidity : 74 % RH

*Table 5 Radiated Emissions for 30MHz    1GHz [CH 1, Horizontal]*

<i>Radiated Emission</i>				<i>Correction Factors</i>	<i>Corrected Amplitude</i>	<i>FCC Class B ( 3 m )</i>	
<i>Frequency (MHz)</i>	<i>Amplitude (dBmV/m)</i>	<i>Ant. H. (m)</i>	<i>Table ( ° )</i>			<i>Limit (dBmV/m)</i>	<i>Margin (dB)</i>
71.99	8.21	4.00	291	12.24	20.45	40.00	-19.55
153.32	2.06	1.00	343	17.48	19.54	43.50	-23.96
233.09	13.79	1.00	101	18.55	32.34	46.00	-13.66
*260.32	11.79	1.00	101	19.66	31.45	46.00	-14.55
398.40	1.71	1.00	270	25.24	26.95	46.00	-19.05
638.00	6.37	1.00	303	30.90	37.27	46.00	-8.73
---							

Note:

1. “\*” means “Restricted band”
2. Margin = Corrected Amplitude – Limit.
3. Peak Amplitude + Correction Factors = Corrected Amplitude

**Table 6 Radiated Emissions For 30MHz 1GHz [CH 1, Vertical]**

<b>Radiated Emission</b>				<b>Correction Factors</b> (dB)	<b>Corrected Amplitude</b> (dBmV/m)	<b>FCC Class B (3 m)</b>	
<b>Frequency (MHz)</b>	<b>Amplitude (dBmV/m)</b>	<b>Ant. H. (m)</b>	<b>Table ( ° )</b>			<b>Limit (dBmV/m)</b>	<b>Margin (dB)</b>
193.08	10.22	1.00	236	16.95	27.17	43.50	-16.33
*259.99	9.73	2.50	350	19.64	29.37	46.00	-16.63
300.99	7.84	2.50	29	21.54	29.38	46.00	-16.62
390.72	9.41	1.00	144	24.82	34.23	46.00	-11.77
528.09	7.01	1.00	84	28.72	35.73	46.00	-10.27
638.00	7.31	1.00	350	30.90	38.21	46.00	-7.79
---							

**Table 7 Open Field Radiated Emissions For 1GHz 18GHz [Channel 1, Horizontal]**

<i>Radiated Emission</i>				<i>Corrected Amplitude</i>		<i>FCC Class B ( 3m )</i>			
<i>Frequency (GHz)</i>	<i>Amplitude (dBm V/m)</i>	<i>Ant. H. (m)</i>	<i>Table ( ° )</i>	<i>Peak</i>	<i>Average</i>	<i>Limit</i>		<i>Margin (dB)</i>	
						<i>Peak</i>	<i>Ave.</i>		
2.413	99.69	1.00	82	99.69	---	---	---	---	
*4.825	40.54	1.00	194	40.54	---	74.0	54.0	-13.46	
---									

**Table 8 Open Field Radiated Emissions For 1GHz 18GHz [Channel 1, Vertical]**

<i>Radiated Emission</i>				<i>Corrected Amplitude</i>		<i>FCC Class B ( 3m )</i>			
<i>Frequency (GHz)</i>	<i>Amplitude (dBm V/m)</i>	<i>Ant. H. (m)</i>	<i>Table ( ° )</i>	<i>Peak</i>	<i>Average</i>	<i>Limit</i>		<i>Margin (dB)</i>	
						<i>Peak</i>	<i>Ave.</i>		
2.413	108.16	1.00	286	108.16	---	---	---	---	
*4.825	40.54	1.00	19	40.54	---	74.0	54.0	-13.46	
---									

Note:

1. Margin = Corrected - Limit.
2. The “ \* “ means restricted bands.
3. The EUT utilizes a *permanently attached antenna*. In addition the spurious RF conducted emissions levels do comply with the *20dBc limit* both at its band-edges and other spurious emissions.
4. As stated in Section 15.35(b), for any frequencies above 1000MHz, radiated limits shown are based upon the use of measurement instrumentation employing an average detector function. As the results of our test, the peak amplitudes are already below the FCC limit. Thus the average amplitudes of the rest are omitted.
5. Above emissions of 10GHz, they are all under the limits of 20dB in Test Site.

**Table 9 Radiated Emissions for 30MHz 1GHz [CH 6, Horizontal]**

Radiated Emission				Correction Factors (dB)	Corrected Amplitude (dBmV/m)	FCC Class B (3 m)	
Frequency (MHz)	Amplitude (dBmV/m)	Ant. H. (m)	Table ( ° )			Limit (dBmV/m)	Margin (dB)
84.00	10.13	4.00	313	13.33	23.46	40.00	-16.54
199.75	11.10	1.00	111	17.22	28.32	43.50	-15.18
*259.98	15.66	1.00	133	19.64	35.30	46.00	-10.70
*325.85	11.79	1.00	282	22.06	33.85	46.00	-12.15
396.00	0.46	1.00	265	25.11	25.57	46.00	-20.43
638.00	6.37	1.00	306	30.90	37.27	46.00	-8.73
---							

**Table 10 Radiated Emissions for 30MHz 1GHz [CH 6, Vertical]**

Radiated Emission				Correction Factors (dB)	Corrected Amplitude (dBmV/m)	FCC Class B (3 m)	
Frequency (MHz)	Amplitude (dBmV/m)	Ant. H. (m)	Table ( ° )			Limit (dBmV/m)	Margin (dB)
72.44	17.35	4.00	222	12.28	29.63	40.00	-10.37
96.00	14.14	4.00	214	14.62	28.76	43.50	-14.74
233.23	4.92	2.50	60	18.55	23.47	46.00	-22.53
*260.04	10.26	2.50	47	19.64	29.90	46.00	-16.10
528.34	10.16	1.00	71	28.73	38.89	46.00	-7.11
638.00	8.45	1.00	358	30.90	39.35	46.00	-6.65
---							

**Table 11 Open Field Radiated Emissions for 1GHz ~ 18GHz [Channel 6, Horizontal]**

<i>Radiated Emission</i>				<i>Corrected Amplitude</i>		<i>FCC Class B ( 3m )</i>		
<i>Frequency (GHz)</i>	<i>Amplitude (dBm V/m)</i>	<i>Ant. H. (m)</i>	<i>Table ( ° )</i>	<i>Peak</i>	<i>Average</i>	<i>Limit</i>		<i>Margin (dB)</i>
						<i>Peak</i>	<i>Ave.</i>	
2.439	98.96	1.00	194	98.96	---	---	---	---
---								

**Table 12 Open Field Radiated Emissions for 1GHz ~ 18GHz [Channel 6, Vertical]**

<i>Radiated Emission</i>				<i>Corrected Amplitude</i>		<i>FCC Class B ( 3m )</i>		
<i>Frequency (GHz)</i>	<i>Amplitude (dBm V/m)</i>	<i>Ant. H. (m)</i>	<i>Table ( ° )</i>	<i>Peak</i>	<i>Average</i>	<i>Limit</i>		<i>Margin (dB)</i>
						<i>Peak</i>	<i>Ave.</i>	
2.439	105.98	1.00	83	105.98	---	---	---	---
*4.873	41.23	1.00	221	41.23	---	74.0	54.0	-12.77
---								



Table 13 Radiated Emissions for 30MHz 1GHz [CH11, Horizontal]

Radiated Emission				Correction Factors (dB)	Corrected Amplitude (dBmV/m)	FCC Class B (3 m)	
Frequency (MHz)	Amplitude (dBmV/m)	Ant. H. (m)	Table ( ° )			Limit (dBmV/m)	Margin (dB)
*73.04	17.47	1.00	106	12.34	29.81	40.00	-10.19
232.83	6.73	1.00	112	18.55	25.28	46.00	-20.72
*260.05	15.42	1.00	129	19.64	35.06	46.00	-10.94
288.87	13.60	1.00	208	20.79	34.39	46.00	-11.61
388.24	2.48	1.00	263	24.68	27.16	46.00	-18.84
638.00	6.25	1.00	299	30.90	37.15	46.00	-8.85
---							

Table 14 Radiated Emissions for 30MHz 1GHz [CH 11, Vertical]

Radiated Emission				Correction Factors (dB)	Corrected Amplitude (dBmV/m)	FCC Class B (3 m)	
Frequency (MHz)	Amplitude (dBmV/m)	Ant. H. (m)	Table ( ° )			Limit (dBmV/m)	Margin (dB)
71.99	7.89	2.50	14	12.24	20.13	40.00	-19.87
*168.00	3.86	1.00	220	16.51	20.37	43.50	-23.13
*260.88	5.10	2.50	29	19.70	24.80	46.00	-21.20
390.72	10.92	1.00	143	24.82	35.74	46.00	-10.26
528.34	10.09	1.00	74	28.73	38.82	46.00	-7.18
638.00	7.43	1.00	347	30.90	38.33	46.00	-7.67
---							

**Table 15 Open Field Radiated Emissions For 1GHz 18GHz [Channel 11, Horizontal]**

<i>Radiated Emission</i>				<i>Corrected Amplitude</i>		<i>FCC Class B ( 3m )</i>		
<i>Frequency (GHz)</i>	<i>Amplitude (dBmV/m)</i>	<i>Ant. H. (m)</i>	<i>Table ( ° )</i>	<i>Peak</i>	<i>Average</i>	<i>Limit</i>		<i>Margin (dB)</i>
						<i>Peak</i>	<i>Ave.</i>	
2.465	99.29	1.00	251	99.29	---	---	---	---
---								

**Table 16 Open Field Radiated Emissions For 1GHz 18GHz [Channel 11, Vertical]**

<i>Radiated Emission</i>				<i>Corrected Amplitude</i>		<i>FCC Class B ( 3m )</i>		
<i>Frequency (GHz)</i>	<i>Amplitude (dBmV/m)</i>	<i>Ant. H. (m)</i>	<i>Table ( ° )</i>	<i>Peak</i>	<i>Average</i>	<i>Limit</i>		<i>Margin (dB)</i>
						<i>Peak</i>	<i>Ave.</i>	
2.465	106.74	1.00	8	106.74	---	---	---	---
---								

## 8.5 Test Result of the Band-edge Compliance

If any 100 kHz bandwidth outside these frequency bands, the radio frequency power that is produced by the modulation products of the spreading sequence, the information sequence and the carrier frequency shall be either *at least 20 dB below that in any 100 kHz bandwidth within the band that contains the highest level of the desired power or shall not exceed the general levels specified in § 15.209(a)*,

We perform this section by the RADIATED manner, the RBW is set to 100kHz and VBW>RBW. We'd made the observation *up to 10<sup>th</sup> harmonics and the criterion is all the harmonic/spurious emissions must be 20dB below the highest emission level measured*. If the emissions fall in the restricted bands stated in the Part15.205(a) must also *comply with the radiated emission limits specified in Part15.209(a)*.

The following pages show our observations referring to the channel 1 and 11 respectively.

Test Condition & Setup: same as 3.1

Channel 1

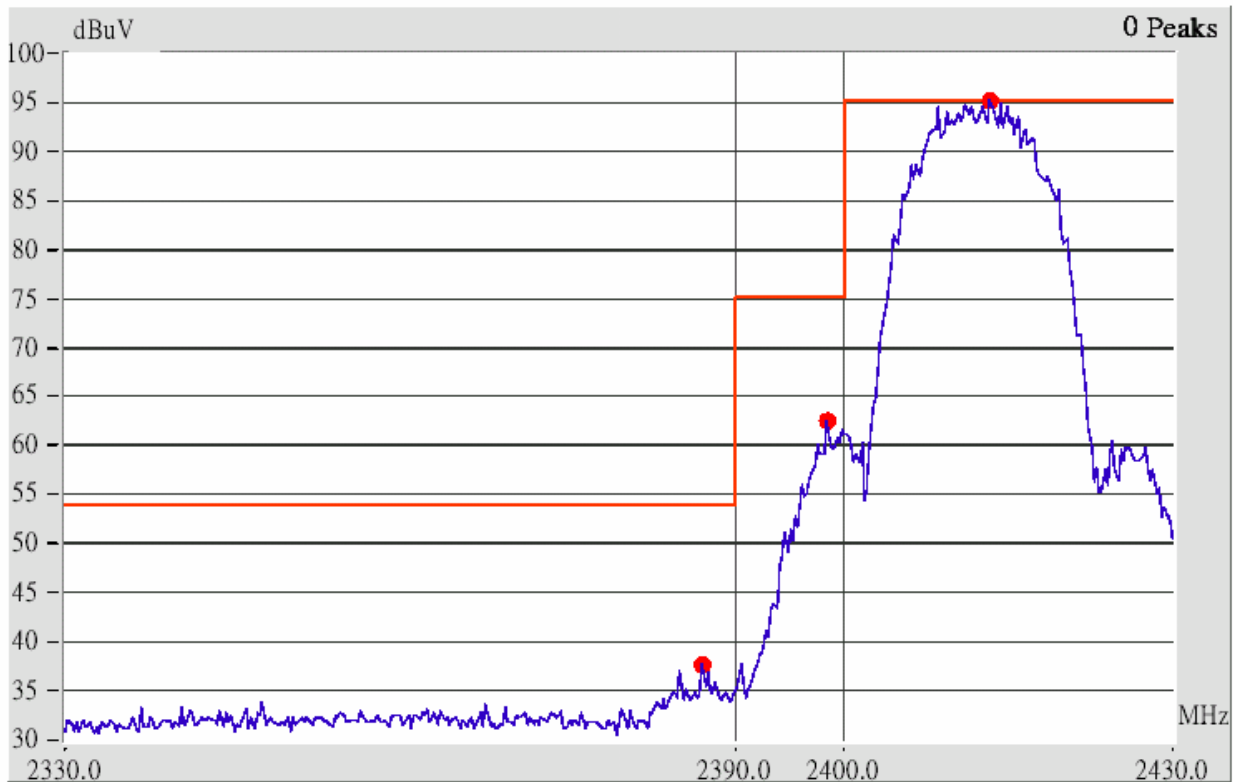

This is the hard copy of our band-edge measurement generated by our band-edge testing program. The picture shown above is the band-edge of channel 1.

1. The lobe right by the fundamental side is already 20dB below the highest emission level.
2. The emissions recorded in the restricted band (<2400MHz) is do comply with the Part 15.209(a) – under the limited line marked in red color.

## Channel 11

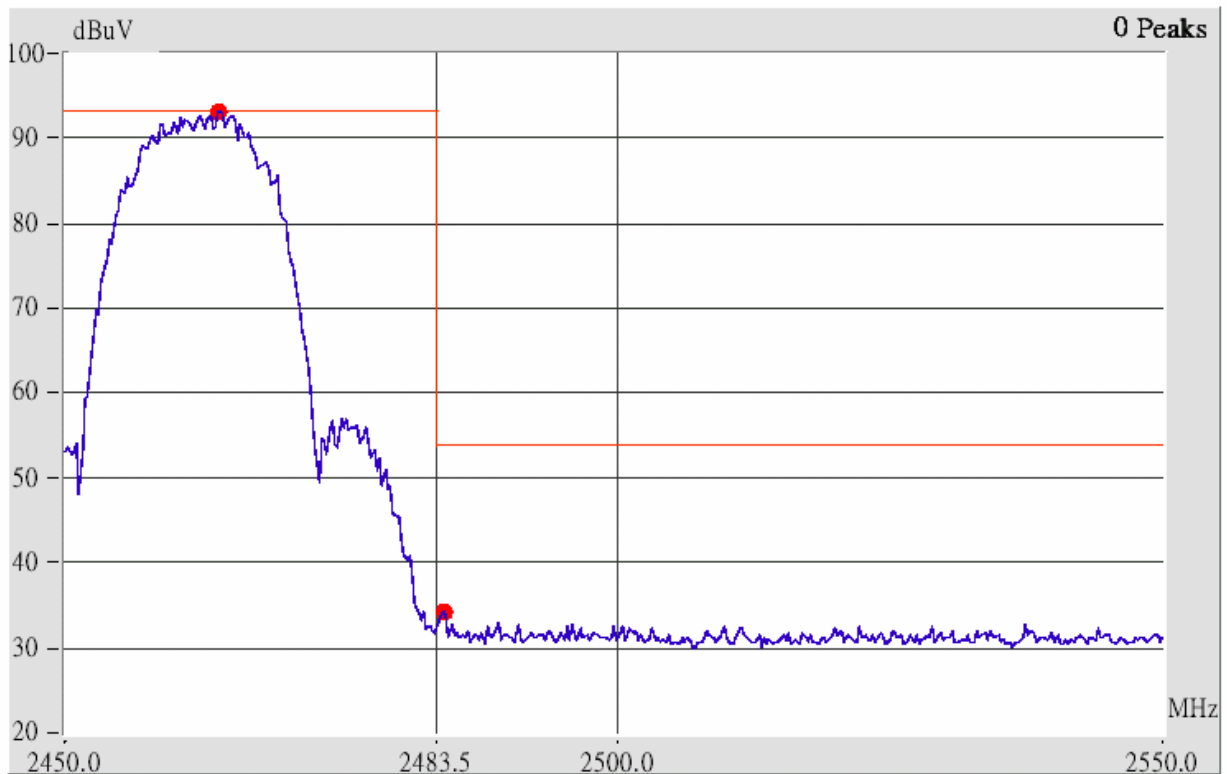

This is the hard copy of our band-edge measurement generated by our band-edge testing program. The picture shown above is the band-edge of channel 11.

3. The lobe right by the fundamental side is already 20dB below the highest emission level.
4. The emissions recorded in the restricted band (>2483.5MHz) is do comply with the Part 15.209(a) – under the limited line marked in red color.

**IX. Section 15.247(d): Power Spectral Density**

**9.1 Test Condition & Setup**

The tests below are running with the EUT transmitter set at high power in TDD mode .A LAN port from a notebook computer connect to the EUT. The EUT is needed to force selection of output power level and channel number. While testing, the EUT was set to transmit continuously and to be tested by the contact manner with the spectrum analyzer.

The attachments below show our observation.

**9.2 Test Instruments Configuration**

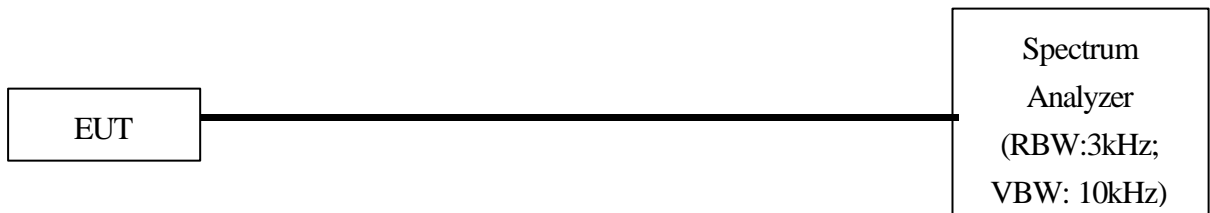

Test Configuration of Power Spectral Density

*P.S.: Notebook computer to control the EUT at maximal power output and channel Number and set antenna kit*

**9.3 List of Test Instruments**

Instrument Name	Model No.	Brand	Serial No.	Last time	Next time
Spectrum Analyzer	8592A	H P	3003AD1401	01/02/02	01/01/03

**9.4 Test Result of Power spectral density**

The following table shows a summary of the test results of the Power Spectral Density.

**FCC ID** : IXMUSB114401

<i>Channel</i>	<i>Frequency (GHz)</i>	<i>Ppr (dBuV)</i>	<i>Cable Loss (dB)</i>	<i>Ppq (dBm)</i>	<i>Limit (dB)</i>	<i>Margin (dB)</i>
CH 01	2.412	-13.35	0.70	-12.65	8.00	-20.65
CH 06	2.437	-14.00	0.70	-13.30	8.00	-21.30
CH 11	2.462	-14.20	0.70	-13.50	8.00	-21.50

Note:

1. The attachment follow by this page and there is no page number.
2. Ppr: spectrum read power density (using peak search mode),  
Ppq: actual peak power density in the spread spectrum band.
3.  $Ppq = Ppr + |Cable Loss|$

Channel 01

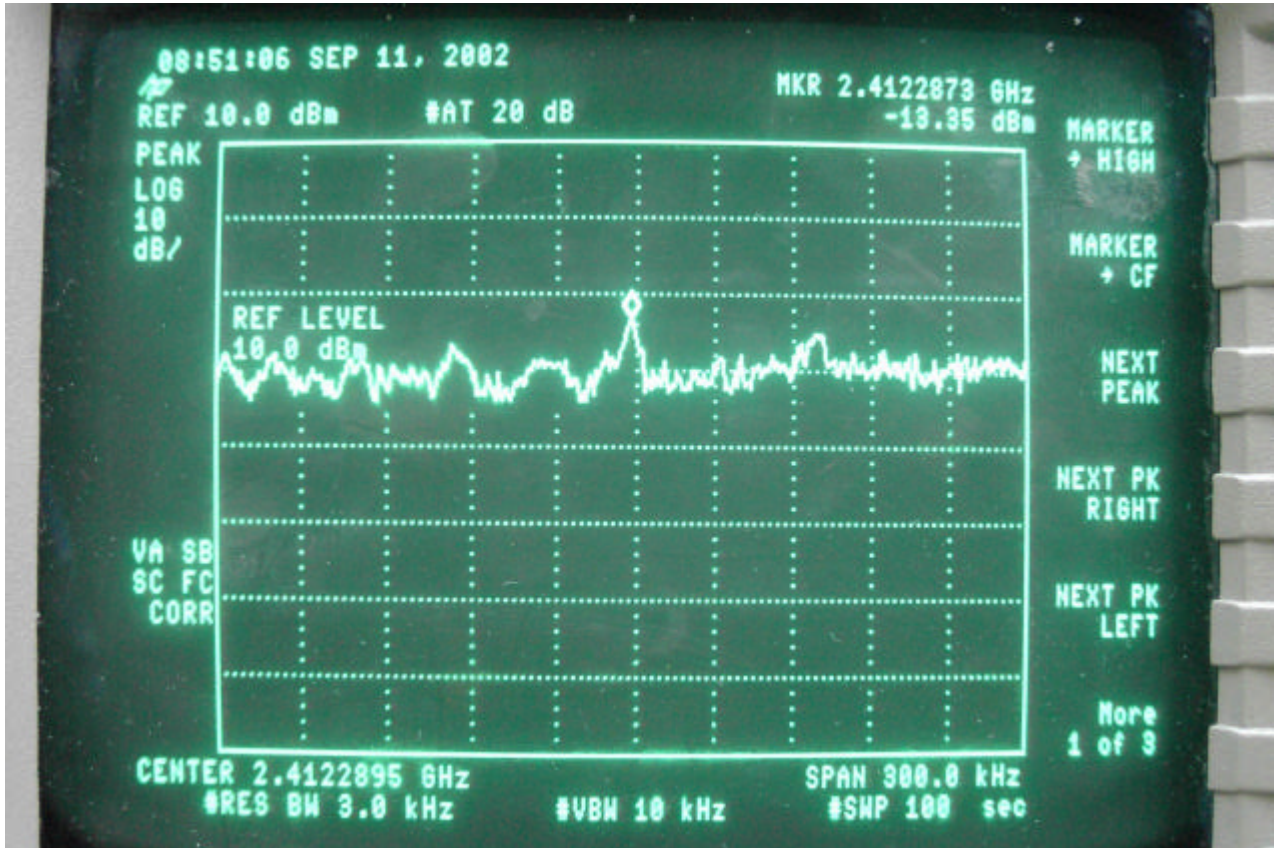



Channel 06

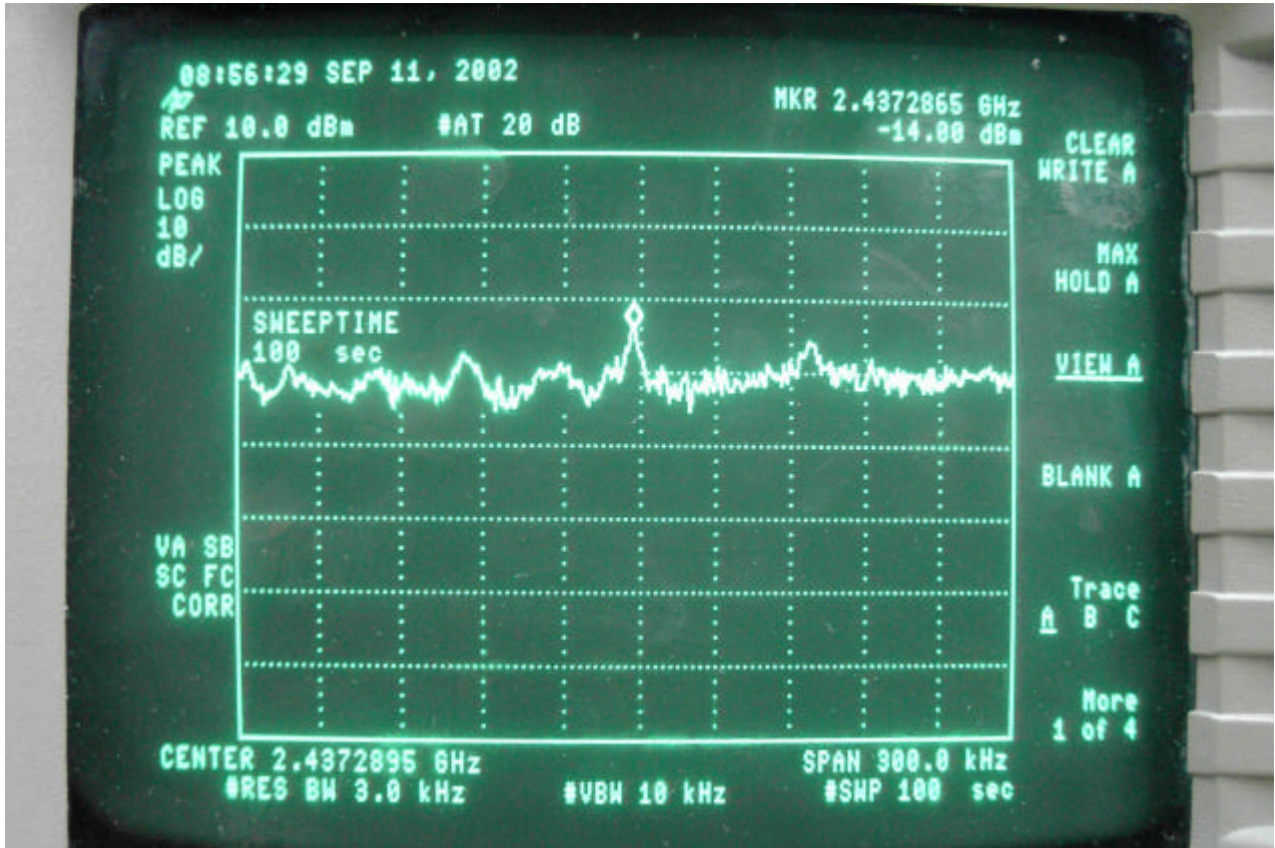

Channel 11

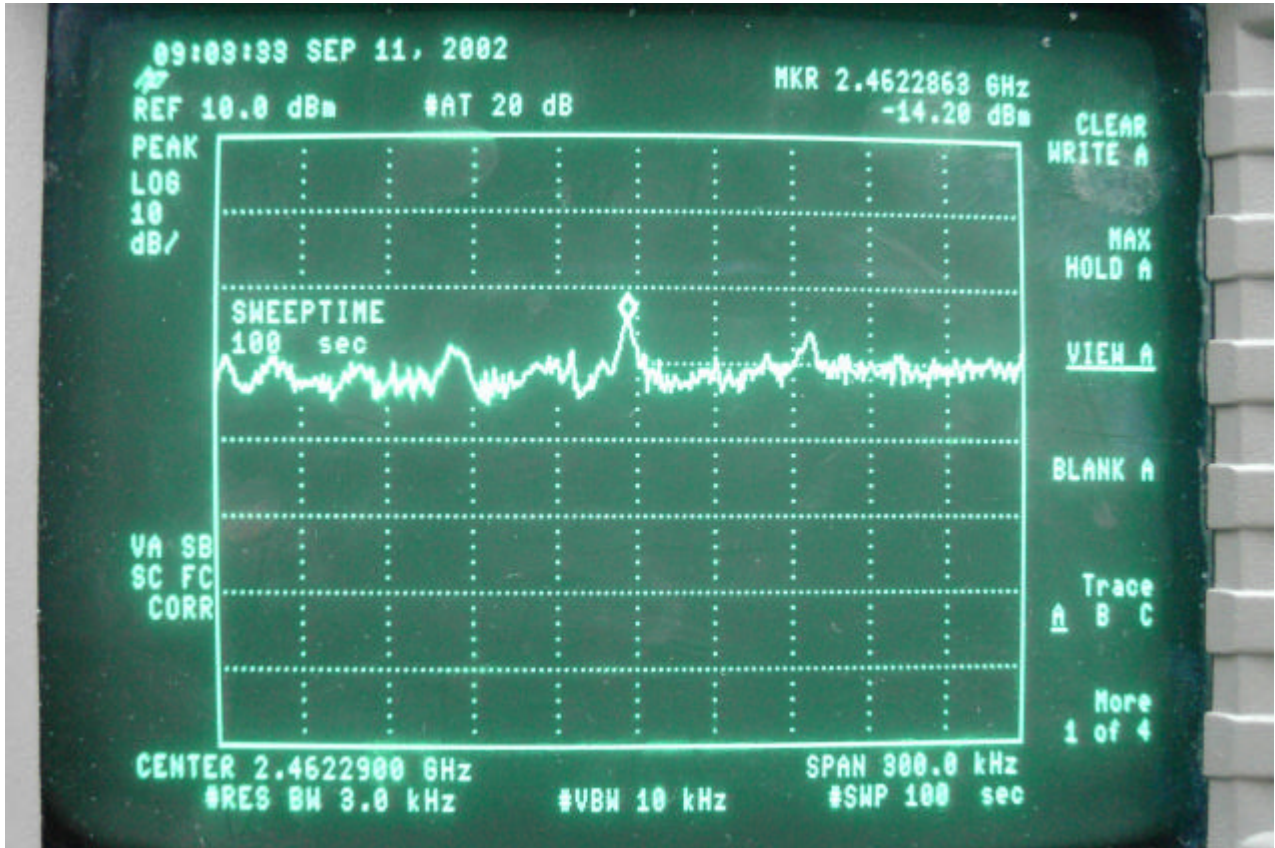

## *Appendix A*

### **Setting up Procedure**

1. Connect the EUT with the notebook computer through the USB interface. Using the USB port of Notebook Computer and software to control the USB Client.
2. Use the software provided by the manufacturer and operated in the Windows to control the EUT's continuous transmission.
3. Then making access to the mode of continuous transmission and set the testing channel.
4. Set different channel being tested and repeat the procedures above.