



# FCC TEST REPORT (PART 27)

**REPORT NO.:** RF971027H08

**MODEL NO.:** RGX210B

**RECEIVED:** Oct. 27, 2008

**TESTED:** Dec. 02, 2008 to Feb. 16, 2009

**ISSUED:** March 10, 2009

**APPLICANT:** UNIVERSAL SCIENTIFIC INDUSTRIAL CO., LTD.

**ADDRESS:** 141, Lane 351, Taiping Road, Sec. 1, Tsao Tuen,  
Nan-Tou, Taiwan, R.O.C.

**ISSUED BY :** Bureau Veritas Consumer Products Services (H.K.)  
Ltd., Taoyuan Branch

**LAB LOCATION :** No. 81-1, Lu Liao Keng, 9th Ling,Wu Lung Tsuen,  
Chiung Lin Hsiang, Hsin Chu Hsien 307, Taiwan

This test report consists of 73 pages in total. It may be duplicated completely for legal use with the approval of the applicant. It should not be reproduced except in full, without the written approval of our laboratory. The client should not use it to claim product endorsement by any government agencies. The test results in the report only apply to the tested sample.



A D T

## TABLE OF CONTENTS

1	CERTIFICATION .....	4
2	SUMMARY OF TEST RESULTS .....	5
2.1	MEASUREMENT UNCERTAINTY .....	6
3	GENERAL INFORMATION.....	7
3.1	GENERAL DESCRIPTION OF EUT.....	7
3.2	DESCRIPTION OF TEST MODES.....	9
3.2.1	TEST MODE APPLICABILITY AND TESTED CHANNEL DETAIL.....	10
3.3	GENERAL DESCRIPTION OF APPLIED STANDARDS.....	12
3.4	DESCRIPTION OF SUPPORT UNITS .....	13
3.4.1	CONFIGURATION OF SYSTEM UNDER TEST .....	14
4	TEST TYPES AND RESULTS .....	15
4.1	OUTPUT POWER MEASUREMENT .....	15
4.1.1	LIMITS OF OUTPUT POWER MEASUREMENT .....	15
4.1.2	TEST INSTRUMENTS .....	15
4.1.3	TEST PROCEDURES.....	16
4.1.4	TEST SETUP.....	17
4.1.5	EUT OPERATING CONDITIONS.....	17
4.1.6	TEST RESULTS.....	18
4.2	FREQUENCY STABILITY MEASUREMENT.....	26
4.2.1	LIMITS OF FREQUENCY STABILITY MEASUREMENT .....	26
4.2.2	TEST INSTRUMENTS .....	26
4.2.3	TEST PROCEDURE.....	27
4.2.4	TEST SETUP.....	27
4.2.5	TEST RESULTS.....	28
4.3	EMISSION BANDWIDTH MEASUREMENT.....	29
4.3.1	LIMITS OF EMISSION BANDWIDTH MEASUREMENT .....	29
4.3.2	TEST INSTRUMENTS .....	29
4.3.3	TEST SETUP.....	29
4.3.4	TEST PROCEDURES.....	30
4.3.5	TEST RESULTS.....	31
4.4	CHANNEL EDGE MEASUREMENT .....	35
4.4.1	LIMITS OF CHANNEL EDGE MEASUREMENT .....	35
4.4.2	TEST INSTRUMENTS .....	35
4.4.3	TEST SETUP .....	35
4.4.4	TEST PROCEDURES.....	36
4.4.5	EUT OPERATING CONDITION .....	36
4.4.6	TEST RESULTS.....	37
4.5	CONDUCTED SPURIOUS EMISSIONS .....	43
4.5.1	LIMITS OF CONDUCTED SPURIOUS EMISSIONS MEASUREMENT .....	43



A D T

4.5.2	TEST INSTRUMENTS .....	43
4.5.3	TEST PROCEDURE .....	44
4.5.4	TEST SETUP .....	44
4.5.5	EUT OPERATING CONDITIONS .....	44
4.5.6	TEST RESULTS.....	45
4.6	RADIATED EMISSION MEASUREMENT (BELOW 1GHz) .....	57
4.6.1	LIMITS OF RADIATED EMISSION MEASUREMENT .....	57
4.6.2	TEST INSTRUMENTS .....	57
4.6.3	TEST PROCEDURES.....	58
4.6.4	DEVIATION FROM TEST STANDARD .....	58
4.6.5	TEST SETUP .....	59
4.6.6	EUT OPERATING CONDITIONS .....	59
4.6.7	TEST RESULTS.....	60
4.7	RADIATED EMISSION MEASUREMENT (ABOVE 1GHz).....	62
4.7.1	LIMITS OF RADIATED EMISSION MEASUREMENT .....	62
4.7.2	TEST INSTRUMENTS .....	62
4.7.3	TEST PROCEDURES.....	63
4.7.4	DEVIATION FROM TEST STANDARD .....	63
4.7.5	TEST SETUP .....	64
4.7.6	EUT OPERATING CONDITIONS .....	64
4.7.7	TEST RESULTS.....	65
5	PHOTOGRAPHS OF THE TEST CONFIGURATION .....	71
6	INFORMATION ON THE TESTING LABORATORIES .....	72
7	APPENDIX- A DL/UL RATION FOR TEST .....	73



# 1 CERTIFICATION

**PRODUCT:** WiMAX 16e Indoor VOIP CPE

**BRAND NAME:** USI

**MODEL NO.:** RGX210B

**APPLICANT:** UNIVERSAL SCIENTIFIC INDUSTRIAL CO., LTD.

**TESTED:** Dec. 02, 2008 to Feb. 16, 2009

**TEST SAMPLE:** ENGINEERING SAMPLE

**TEST STANDARDS:** FCC 47 CFR Part 2

FCC 47 CFR Part 27, Subpart C & M

ANSI/TIA/EIA-603-C-2004

The above equipment (Model No.: RGX210B) has been tested by **Bureau Veritas Consumer Products Services (H.K.) Ltd., Taoyuan Branch**, and found compliance with the requirement of the above standards. The test record, data evaluation & Equipment Under Test (EUT) configurations represented herein are true and accurate accounts of the measurements of the sample's EMC characteristics under the conditions specified in this report.

**PREPARED BY** : Midoli Peng , **DATE:** March 10, 2009  
( Midoli Peng, Specialist )

**TECHNICAL ACCEPTANCE** : Hank Chung , **DATE:** March 10, 2009  
Responsible for RF ( Hank Chung, Deputy Manager )

**APPROVED BY** : May Chen , **DATE:** March 10, 2009  
( May Chen, Deputy Manager )

## 2 SUMMARY OF TEST RESULTS

The EUT has been tested according to the following specifications:

<b>APPLIED STANDARD: FCC Part 27 &amp; Part 2</b>			
<b>STANDARD SECTION</b>	<b>TEST TYPE AND LIMIT</b>	<b>RESULT</b>	<b>REMARK</b>
2.1046 27.50(h)(2)	Maximum Peak Output Power Limit: max. 2 watts conducted peak power	PASS	Meet the requirement of limit.
2.1055 27.54	Frequency Stability Stay with the authorized bands of operation	PASS	Meet the requirement of limit.
2.1049 27.53(m)(6)	Emission Bandwidth	PASS	Meet the requirement of limit.
2.1051 27.53(m)(4)(6)	Band Edge Measurements	PASS	Meet the requirement of limit.
2.1051 27.53(m)(4)(6)	Conducted Spurious Emissions	PASS	Meet the requirement of limit.
2.1053 27.53(m)(4)(6)	Radiated Spurious Emissions	PASS	Meet the requirement of limit.



A D T

## 2.1 MEASUREMENT UNCERTAINTY

Where relevant, the following measurement uncertainty levels have been estimated for tests performed on the EUT as specified in CISPR 16-4-2:

This uncertainty represents an expanded uncertainty expressed at approximately the 95% confidence level using a coverage factor of  $k=2$ .

Measurement	Value
Radiated emissions (30MHz-1GHz)	3.94 dB
Radiated emissions (1GHz -18GHz)	2.49 dB
Radiated emissions (18GHz -40GHz)	2.70 dB

### 3 GENERAL INFORMATION

#### 3.1 GENERAL DESCRIPTION OF EUT

<b>PRODUCT</b>	WiMAX 16e Indoor VOIP CPE
<b>MODEL NO.</b>	RGX210B
<b>FCC ID</b>	IXMRGX210B
<b>POWER SUPPLY</b>	DC 12V from Power adapter
<b>MODULATION TECHNOLOGY</b>	OFDMA
<b>MODULATION</b>	QPSK-1/2, -3/4, 16QAM-1/2, 3/4, 64QAM-1/2, -2/3, -3/4 (64QAM for Rx only)
<b>FREQUENCY RANGE</b>	2500MHz ~ 2690MHz
<b>CHANNEL BANDWIDTH</b>	5MHz & 10MHz
<b>MAX. CONDUCTED POWER</b>	5MHz: 25.86dBm 10MHz: 24.09dBm
<b>ANTENNA TYPE</b>	Please see note 1
<b>DATA CABLE</b>	NA
<b>I/O PORTS</b>	VOIP port x 1 LAN port x 1
<b>ASSOCIATED DEVICES</b>	Adapter Power Cord Antenna

**NOTE:**

1. There are two set antennas provided to this EUT, please refer to the following table:

No.	Brand	Model No.	Net Gain (dBi)	Antenna Type	Connector
1	Joymax	JWX-619XRSXX-181	5	Dipole	SMA Reverse
2	Joymax	JWX-171XRSXX-181	5	Dipole	SMA Reverse

From the above antennas, the worst case was found in Antenna: JWX-171XRSXX-181. Therefore only the test data of the antenna was recorded in this report.



A D T

For the EUT Modulation type and coding rate. After pre-testing items of output power and spurious emissions, QPSK-1/2 was found to be worst case, and was selected for the final test configuration.

Up Link		Down Link	
Modulation	Coding rate	Modulation	Coding rate
QPSK	1/2	QPSK	1/2
	3/4		3/4
16QAM	1/2	16QAM	1/2
	3/4		3/4
		64QAM	1/2
			3/4
			5/6

2. The EUT must be supplied with a power adapter and following two different brands could be chosen:

Adapter	Brand	Model No.	Spec.
Adapter 1	Sino-American	SA115B-12	Input: 100-240V ~ 50-60Hz, 0.4A Output: 12V, 1.3A, 15.6W
Adapter 2	UNION EAST	ACE024A-12	Input: 100-240V ~ 50-60Hz, 0.8A Output: 12V, 2A,

3. The EUT was pre-tested in chamber under the following modes:

Test Mode	Description
Mode A	Level-set
Mode B	Tower-set

From the above modes, the worst case was found in **Mode A**. Therefore only the test data of the modes were recorded in this report.

- The EUT embedded a firmware for testing that needs to control from Notebook computer to let EUT with different DL/UL ration.
- The device has different DL/UL ration in normal operation. It was tested with 37.3% (DL:UL= 29:18) and 31.3% (DL:UL=31:16) duty cycle mode for 5MHz and 10MHz, which is the worse mode, and controlled by software. (The detail duty cycle refer to appendix A).
- The above EUT information was declared by manufacturer and for more detailed features description, please refers to the manufacturer's specifications or User's Manual.





A D T

### 3.2 DESCRIPTION OF TEST MODES

Three channels have been tested and presented.

#### **CHANNEL BANDWIDTH: 5MHz**

**Low channel (L):** 2502.5MHz.

**Middle channel (M):** 2600MHz.

**High channel (H):** 2687.5MHz.

#### **CHANNEL BANDWIDTH: 10MHz**

**Low channel (L):** 2505MHz.

**Middle channel (M):** 2600MHz.

**High channel (H):** 2685MHz.



A D T

### 3.2.1 TEST MODE APPLICABILITY AND TESTED CHANNEL DETAIL

EUT CONFIGURE MODE	APPLICABLE TO							DESCRIPTION
	OP	FS	EB	CE	CSE	RE<1G	RE≥1G	
MODE 1	√	√	√	√	√	√	√	Channel Bandwidth: 5MHz
MODE 2	√	√	√	√	√	√	√	Channel Bandwidth: 10MHz

Where **OP**: Output power **FS**: Frequency stability  
**EB**: Emission bandwidth **CE**: Channel edge  
**CSE**: Conducted spurious emissions **RE<1G**: Radiated emission below 1GHz  
**RE≥1G**: Radiated emission above 1GHz

#### **OUTPUT POWER MEASUREMENT:**

- Pre-Scan has been conducted to determine the worst-case mode from all possible combinations between available modulations, data rates, and antenna ports (if EUT with antenna diversity architecture).
- Following channel(s) was (were) selected for the final test as listed below.

TESTED CHANNEL	MODULATION TECHNOLOGY	MODULATION TYPE
L, M, H	OFDMA	QPSK

#### **FREQUENCY STABILITY MEASUREMENT:**

- Pre-Scan has been conducted to determine the worst-case mode from all possible combinations between available modulations, data rates, and antenna ports (if EUT with antenna diversity architecture).
- Following channel(s) was (were) selected for the final test as listed below.

TESTED CHANNEL	MODULATION TECHNOLOGY	MODULATION TYPE
M	OFDMA	Unmodulation

#### **EMISSION BANDWIDTH MEASUREMENT:**

- Pre-Scan has been conducted to determine the worst-case mode from all possible combinations between available modulations, data rates, and antenna ports (if EUT with antenna diversity architecture).
- Following channel(s) was (were) selected for the final test as listed below.

TESTED CHANNEL	MODULATION TECHNOLOGY	MODULATION TYPE
L, M, H	OFDMA	QPSK

**CHANNEL EDGE MEASUREMENT:**

- Pre-Scan has been conducted to determine the worst-case mode from all possible combinations between available modulations, data rates, and antenna ports (if EUT with antenna diversity architecture).
- Following channel(s) was (were) selected for the final test as listed below.

TESTED CHANNEL	MODULATION TECHNOLOGY	MODULATION TYPE
L, M, H	OFDMA	QPSK

**CONDUCTED SPURIOUS EMISSIONS MEASUREMENT:**

- Pre-Scan has been conducted to determine the worst-case mode from all possible combinations between available modulations, data rates, and antenna ports (if EUT with antenna diversity architecture).
- Following channel(s) was (were) selected for the final test as listed below.

TESTED CHANNEL	MODULATION TECHNOLOGY	MODULATION TYPE
L, M, H	OFDMA	QPSK

**RADIATED EMISSION MEASUREMENT (BELOW 1 GHz):**

- Pre-Scan has been conducted to determine the worst-case mode from all possible combinations between available modulations, data rates, and antenna ports (if EUT with antenna diversity architecture).
- Following channel(s) was (were) selected for the final test as listed below.

TESTED CHANNEL	MODULATION TECHNOLOGY	MODULATION TYPE
L	OFDMA	QPSK

**RADIATED EMISSION MEASUREMENT (ABOVE 1 GHz):**

- Pre-Scan has been conducted to determine the worst-case mode from all possible combinations between available modulations, data rates, and antenna ports (if EUT with antenna diversity architecture).
- Following channel(s) was (were) selected for the final test as listed below.

TESTED CHANNEL	MODULATION TECHNOLOGY	MODULATION TYPE
L, M, H	OFDMA	QPSK

### 3.3 GENERAL DESCRIPTION OF APPLIED STANDARDS

The EUT is a RF product. According to the specifications of the manufacturer, it must comply with the requirements of the following standards:

**FCC 47 CFR Part 2**

**FCC 47 CFR Part 27, Subpart C & M**

**ANSI/TIA/EIA-603-C-2004**

All test items have been performed and recorded as per the above standards.

**NOTE:** The EUT is also considered as a kind of computer peripheral, because the connection to computer is necessary for typical use. It has been verified to comply with the requirements of FCC Part 15, Subpart B, Class B (DoC). The test report has been issued separately.



A D T

### 3.4 DESCRIPTION OF SUPPORT UNITS

The EUT has been tested as an independent unit together with other necessary accessories or support units. The following support units or accessories were used to form a representative test configuration during the tests.

NO.	PRODUCT	BRAND	MODEL NO.	SERIAL NO.	FCC ID
1	NOTEBOOK COMPUTER	DELL	PP18L	6976685584	FCC DoC
2	TELEPHONE	ROMEO	TE-812	97280926	N/A

NO.	SIGNAL CABLE DESCRIPTION OF THE ABOVE SUPPORT UNITS
1	NA
2	3.0 m nonshielded telephone wire, terminated with RJ11 connector, w/o core.

**NOTE:** All power cords of the above support units are non shielded (1.8m).

### 3.4.1 CONFIGURATION OF SYSTEM UNDER TEST

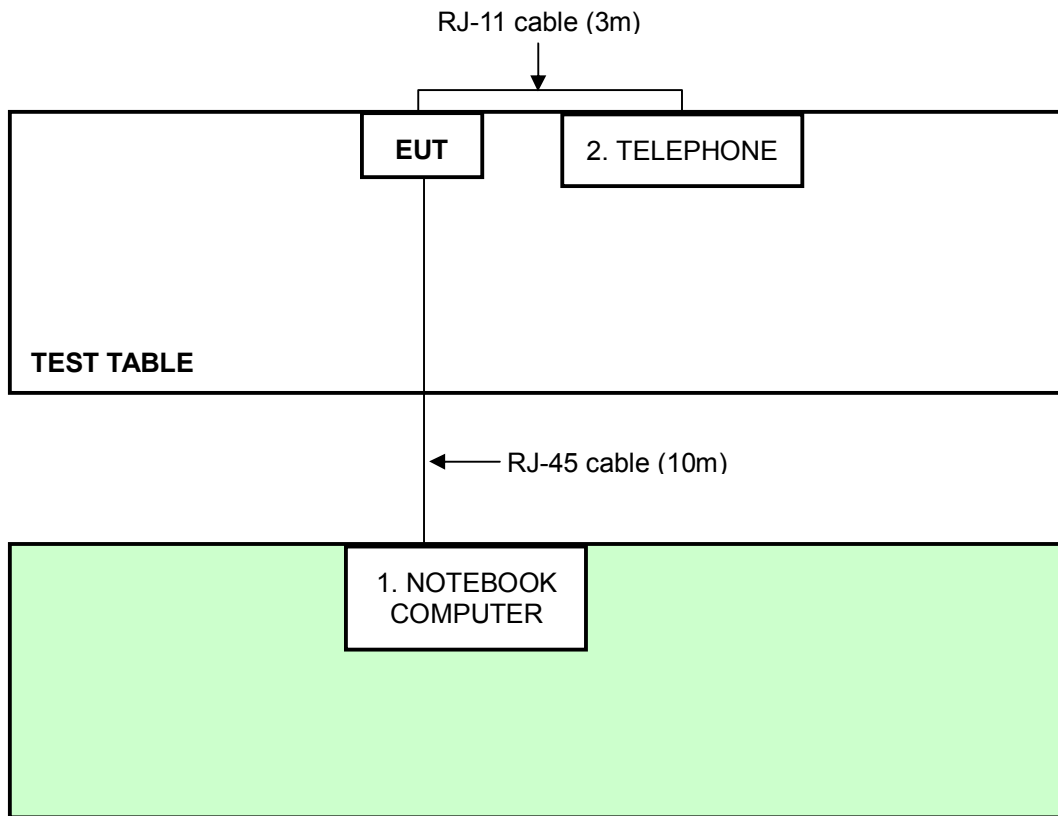



## 4 TEST TYPES AND RESULTS

### 4.1 OUTPUT POWER MEASUREMENT

#### 4.1.1 LIMITS OF OUTPUT POWER MEASUREMENT

The radiated peak output power shall be according to the specific rule Part 27.50(h)(2) that "Other User stations are limited to 2 watts and 27.50(i) specific that "Peak transmit power must be measure over any interval of continuous transmission using instrumentation calibration in terms of rms-equivalent voltage."

#### 4.1.2 TEST INSTRUMENTS

Description & Manufacturer	Model No.	Serial No.	CALIBRATED DATE	CALIBRATED UNTIL
Agilent Spectrum Analyzer	E4440A	MY46185282	June 19, 2008	June 18, 2009
HUBER+SUHNER	SUCOFLEX104	231115/4	May 30, 2008	May 29, 2009

**NOTE:**

The calibration interval of the above test instruments is 12 months and the calibrations are traceable to NML/ROC and NIST/USA.

#### 4.1.3 TEST PROCEDURES

For Conducted Power:

- a. Set span to encompass the entire emission bandwidth (EBW) of the signal.
- b. For Channel bandwidth: 5 MHz:  
Set RBW=51kHz, VBW=150kHz, Detector mode=RMS.
- c. For Channel bandwidth: 10 MHz:  
Set RBW=100kHz, VBW=300kHz, Detector mode= RMS.
- d. Computer power by integrating the spectrum across the 26dB EBW of the signal.
- e. Record the power level.
- f. The “Read Value” is the spectrum reading the maximum power value.



#### 4.1.4 TEST SETUP

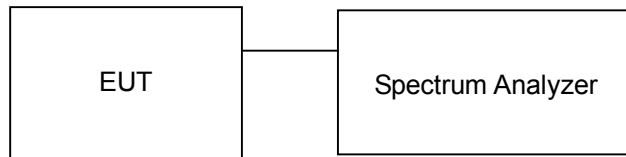

For the actual test configuration, please refer to the related item – Photographs of the Test Configuration.

#### 4.1.5 EUT OPERATING CONDITIONS

1. Placed the EUT on testing table.
2. Prepared other computer system (support unit 1) to act as communication partners and placed them outside of testing area.
3. The communication partners run test program “telnet.exe” to enable EUT under transmission/receiving condition continuously at specific channel frequency.
4. The support unit 1 (Notebook computer) ran a test program “X-Lite.exe “ to enable the support unit 2 (TELEPHONE) was kept up link.



A D T

#### 4.1.6 TEST RESULTS

##### CHANNEL BANDWIDTH: 5MHz

<b>INPUT POWER</b>	120Vac, 60Hz	<b>DETECTOR FUNCTION</b>	RMS
<b>ENVIRONMENTAL CONDITIONS</b>	25deg°C, 60%RH 960hPa	<b>TESTED BY</b>	Wen Yu

CONDUCTED POWER			
CHANNEL	FREQUENCY (MHz)	POWER OUTPUT(mW)	POWER OUTPUT(dBm)
Low	2502.5	358.922	25.55
Middle	2600	385.478	25.86
High	2687.5	378.443	25.78



A D T

LOW CHANNEL

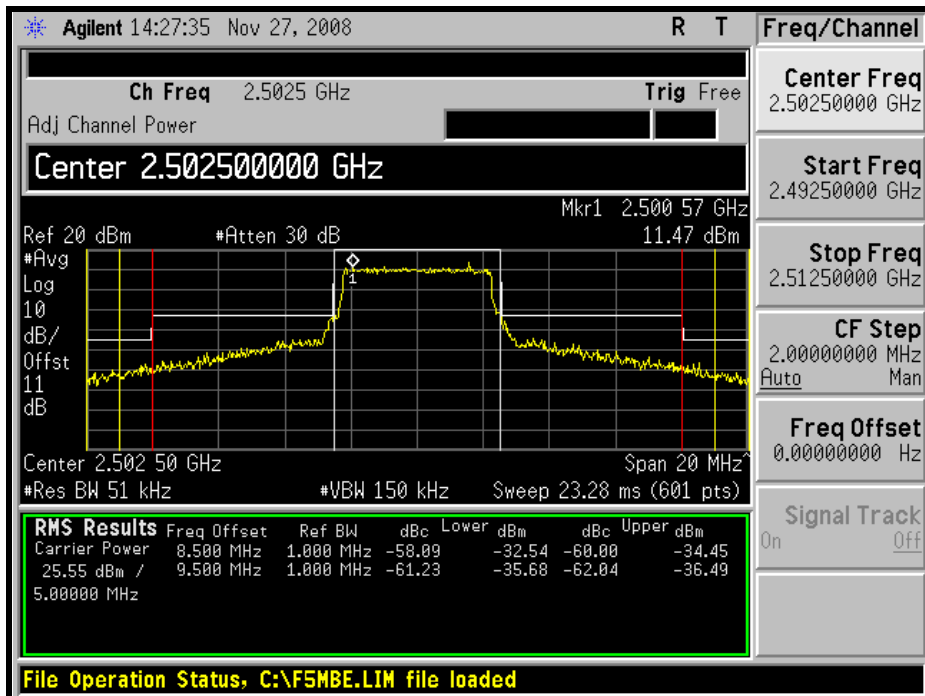
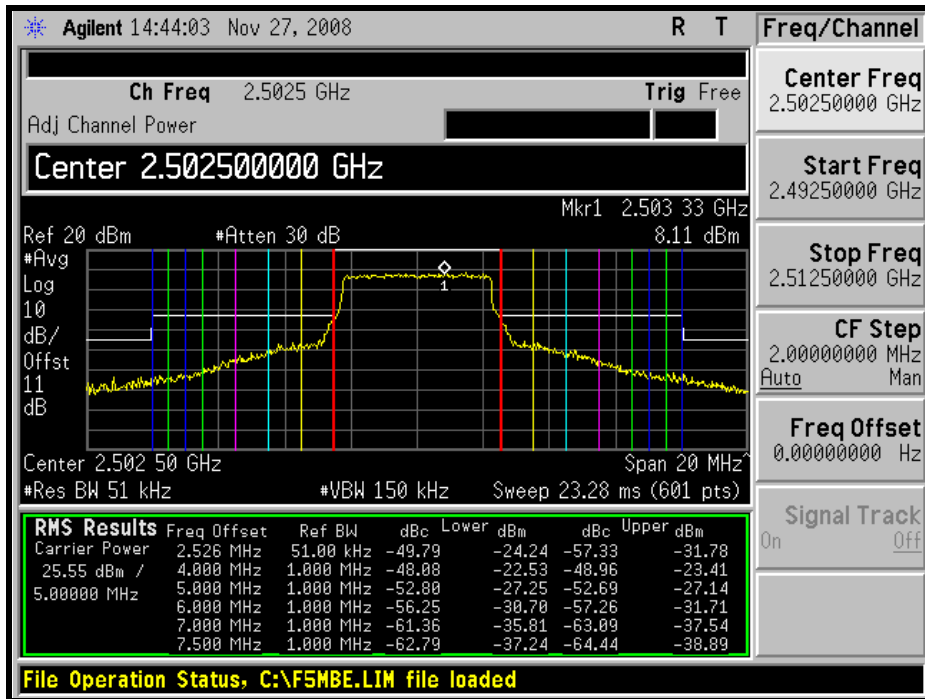



A D T

MIDDLE CHANNEL

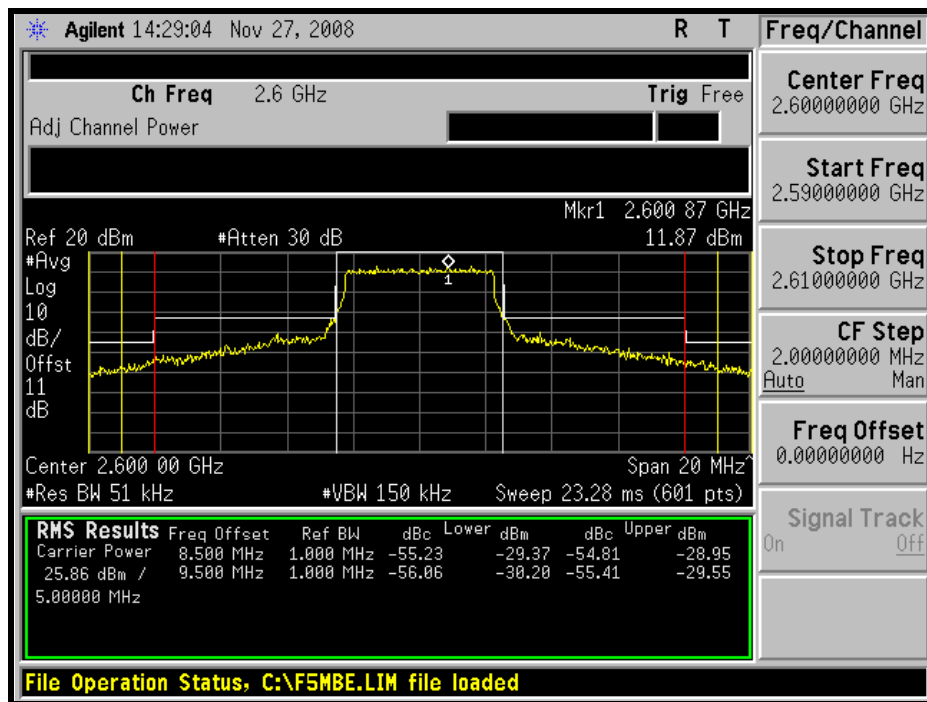
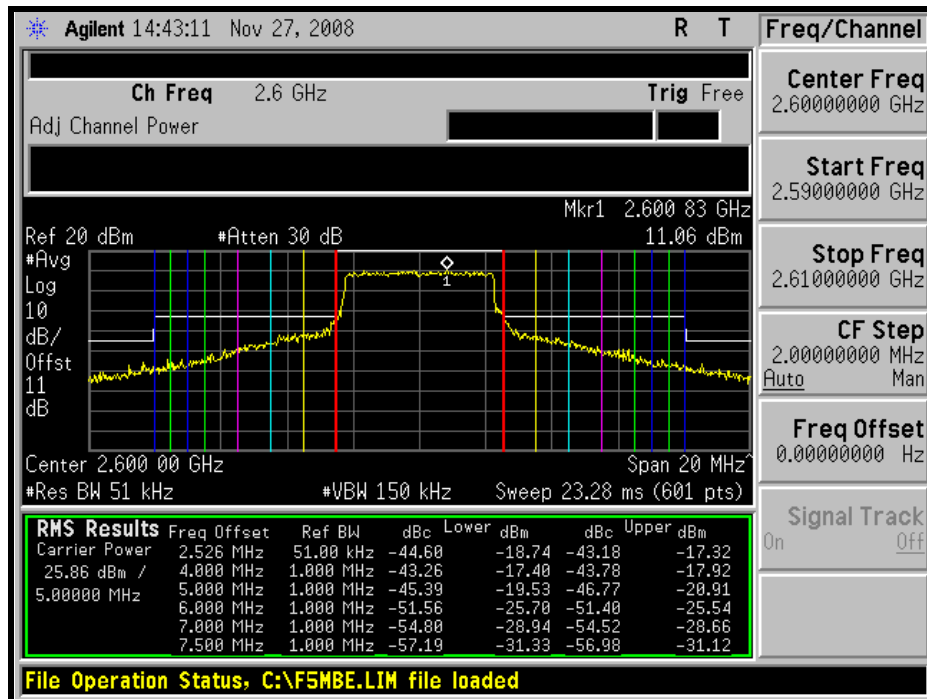



A D T

### HIGH CHANNEL

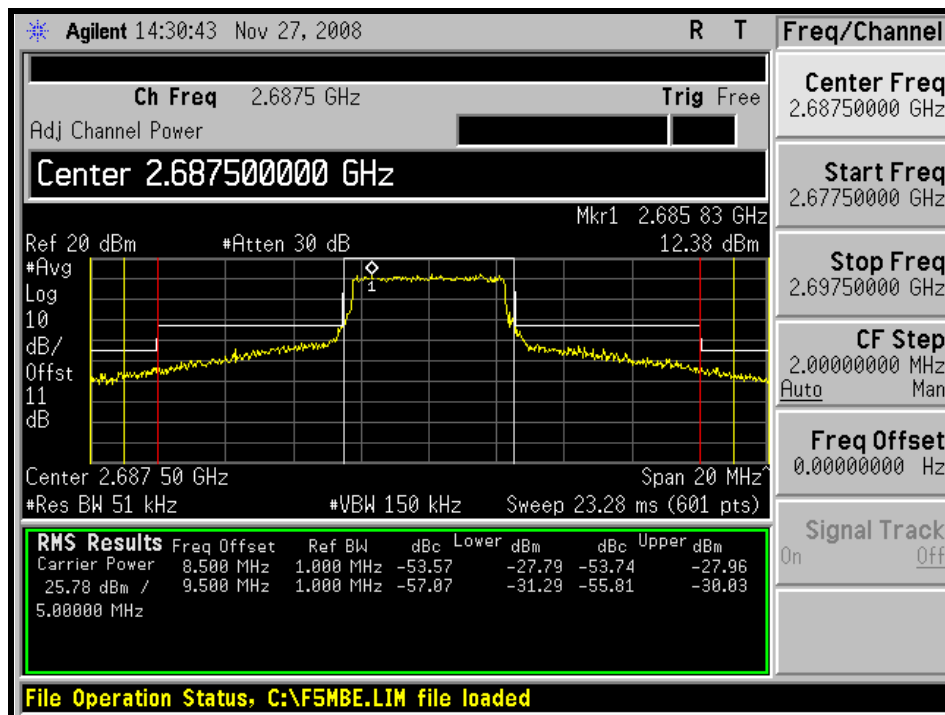
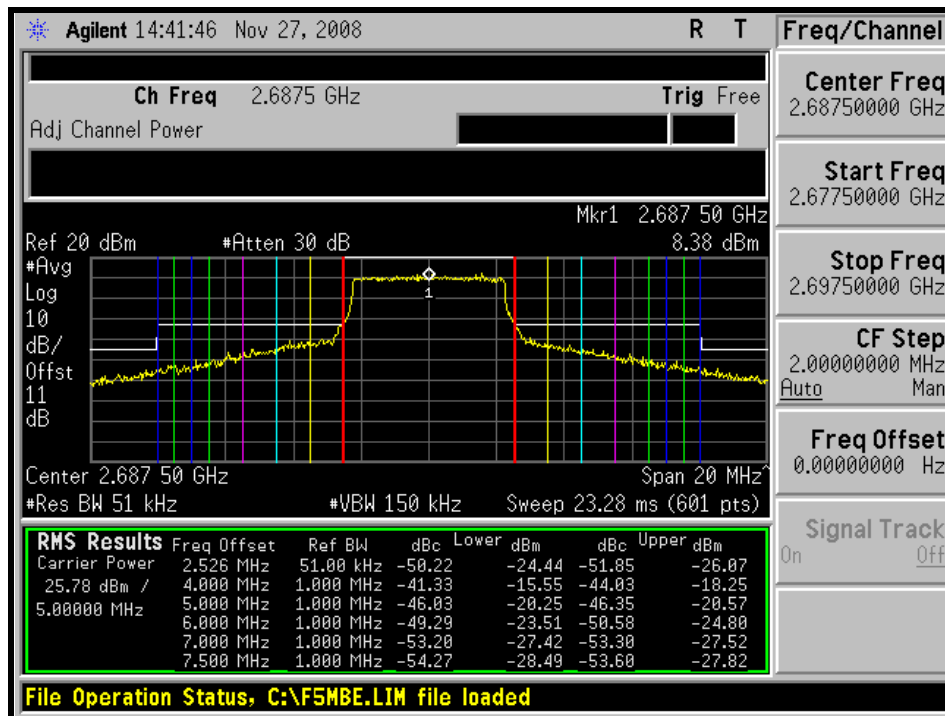



A D T

**CHANNEL BANDWIDTH: 10MHz**

<b>INPUT POWER</b>	120Vac, 60Hz	<b>DETECTOR FUNCTION</b>	RMS
<b>ENVIRONMENTAL CONDITIONS</b>	25deg°C, 60%RH 960hPa	<b>TESTED BY</b>	Wen Yu

<b>CONDUCTED POWER</b>			
<b>CHANNEL</b>	<b>FREQUENCY (MHz)</b>	<b>POWER OUTPUT(mW)</b>	<b>POWER OUTPUT(dBm)</b>
Low	2505	228.560	23.59
Middle	2600	230.144	23.62
High	2685	256.448	24.09



A D T

LOW CHANNEL

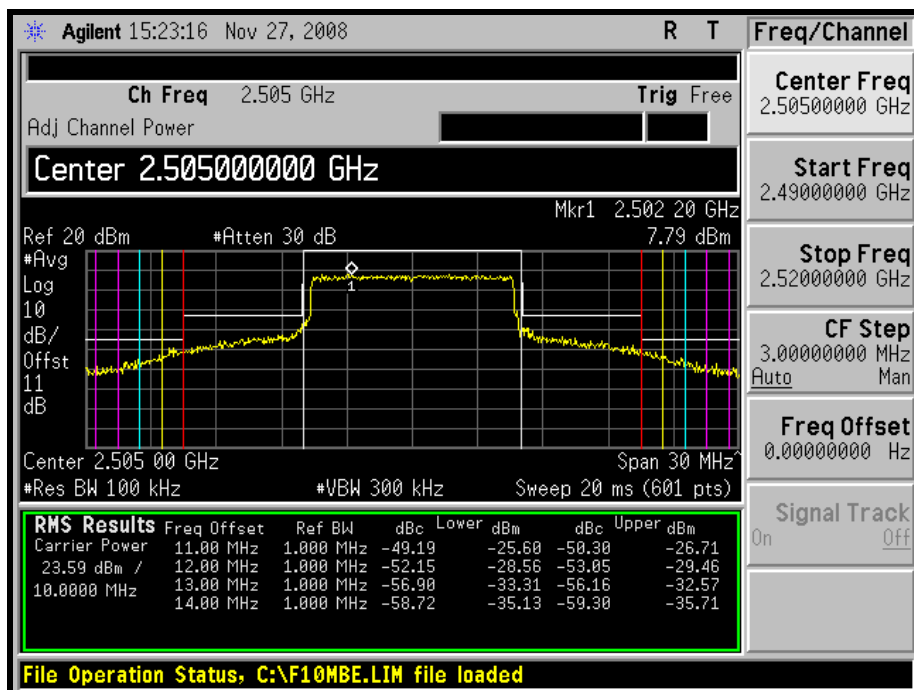
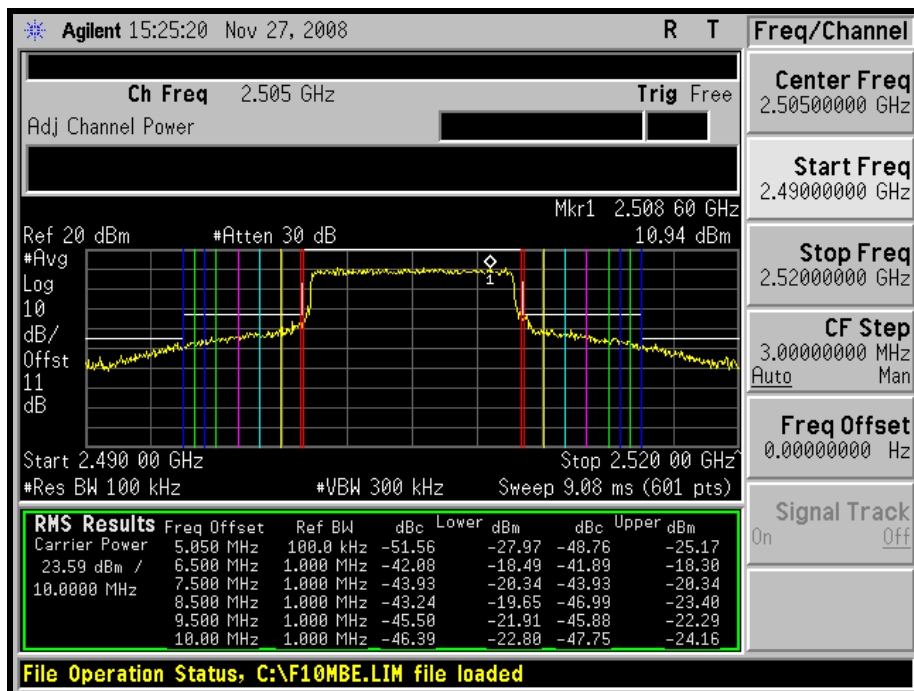



A D T

MIDDLE CHANNEL

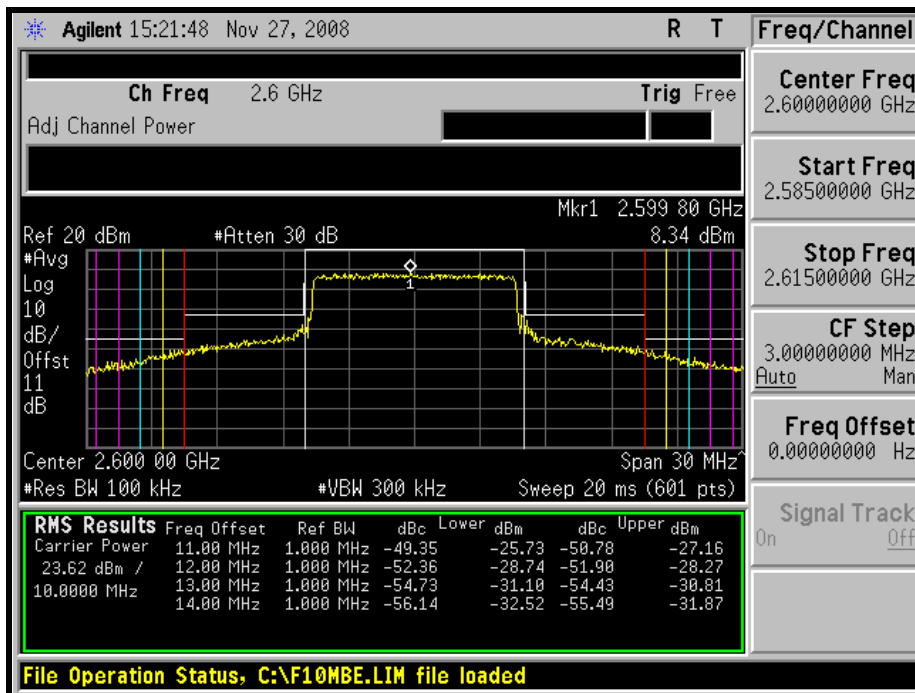
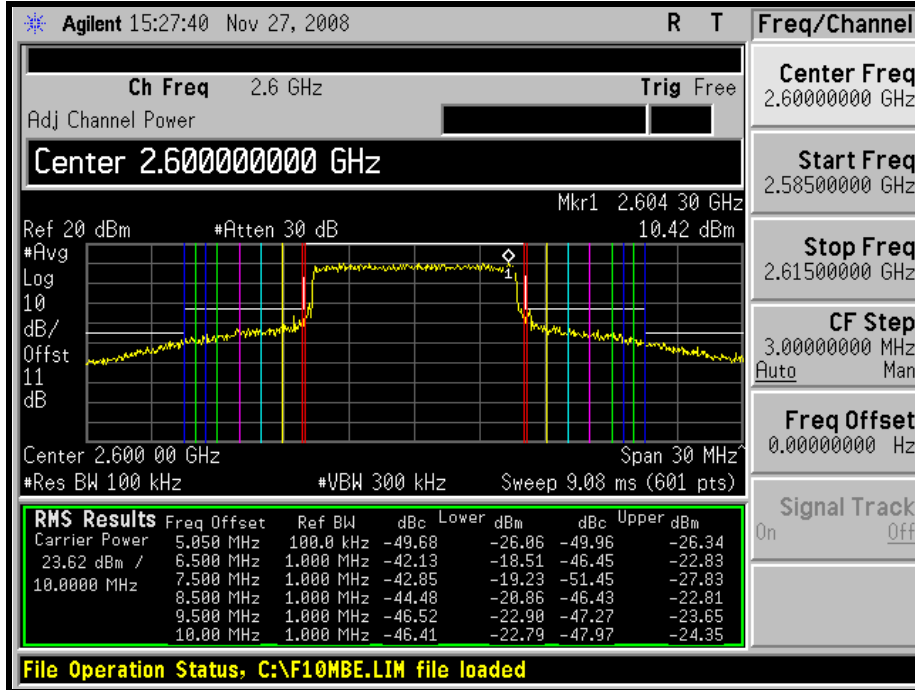





A D T

### HIGH CHANNEL

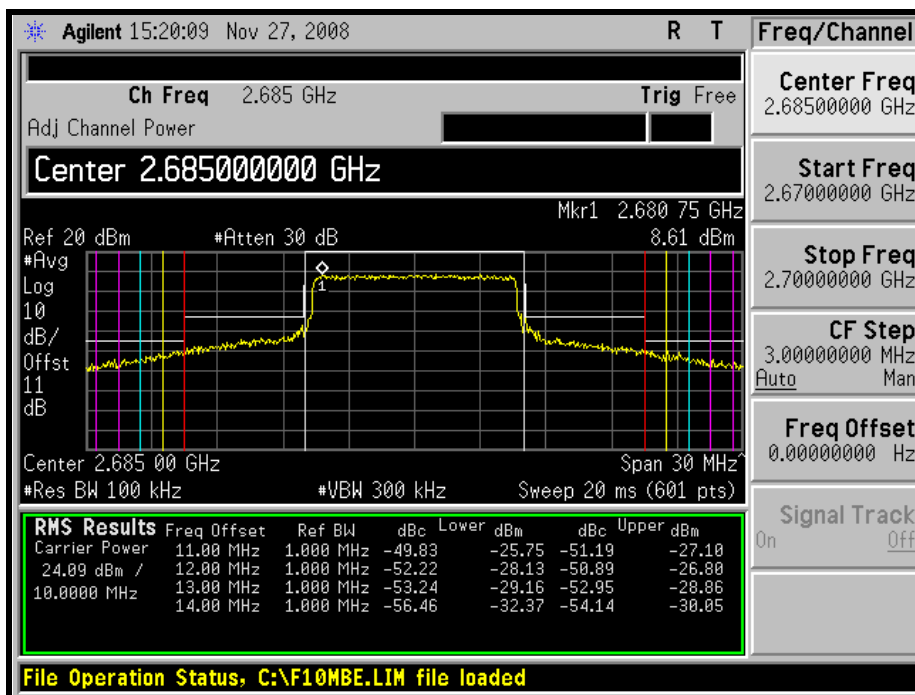
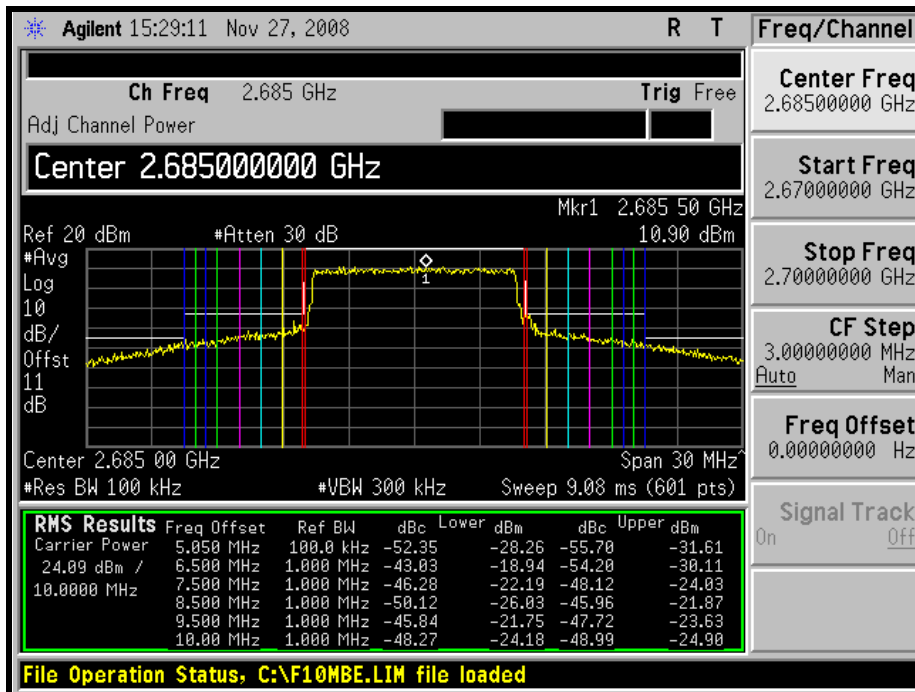



## 4.2 FREQUENCY STABILITY MEASUREMENT

### 4.2.1 LIMITS OF FREQUENCY STABILITY MEASUREMENT

According to the FCC part 2.1055 shall be tested the frequency stability. The rule is defined that "The frequency stability shall be sufficient to ensure that the fundamental emission stays within the authorized frequency block." The test extreme voltage is according to the 2.1055(d)(1) Vary primary supply voltage from 85 to 115 percent of the nominal value for other than hand carried battery equipment and the extreme temperature rule is comply with specification of EUT  $-30^{\circ}\text{C} \sim 60^{\circ}\text{C}$ .

### 4.2.2 TEST INSTRUMENTS

DESCRIPTION & MANUFACTURER	MODEL NO.	SERIAL NO.	CALIBRATED DATE	CALIBRATED UNTIL
R&S SPECTRUM ANALYZER	FSP40	100037	Aug. 09, 2008	Aug. 08, 2009
OVEN	MHU-225AU	911033	Dec. 18, 2008	Dec. 17, 2009
HUBER+SUHNER	SUCOFLEX104	231115/4	May 03, 2008	Nov. 02, 2009
AC POWER SOURCE	6205	1140503	N/A	N/A

**NOTE:** 1. The calibration interval of the above test instruments is 12 months. And the calibrations are traceable to NML/ROC and NIST/USA.

#### 4.2.3 TEST PROCEDURE

- a. Power must be removed when changing from one temperature to another or one voltage to another voltage. Power warm up is at least 15 min and power applied should perform before recording frequency error.
- b. EUT is connected the external power supply to control the AC input power. The various Volts from the minimum 102 Volts to 138 Volts. Each step shall be record the frequency error rate.
- c. The temperature range step is 10 degrees in this test items. All temperature levels shall be hold the  $\pm 0.5^{\circ}\text{C}$  during the measurement testing.
- d. The each temperature step shall be at least 0.5 hours, consider the EUT could be test under the stability condition.

#### 4.2.4 TEST SETUP

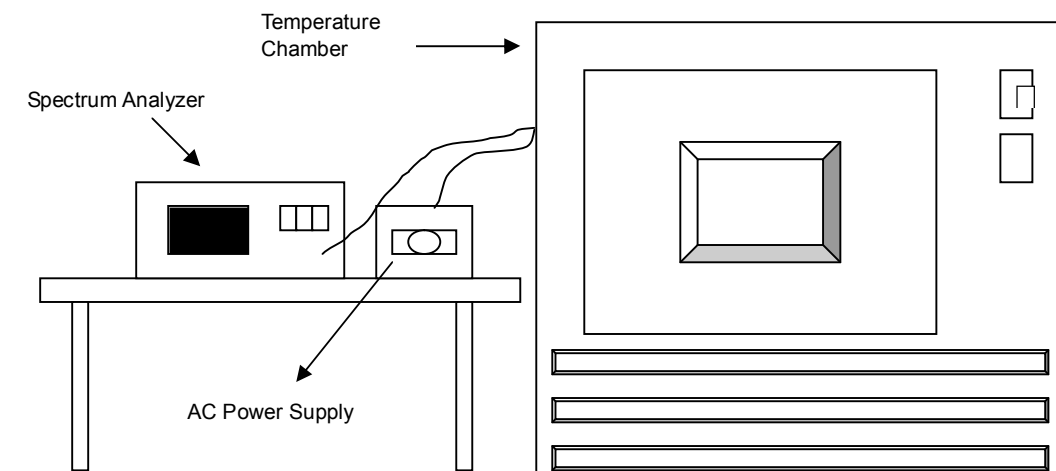



A D T

#### 4.2.5 TEST RESULTS

<b>MODE</b>	Middle channel (2600MHz)	<b>INPUT POWER</b>	120Vac, 60Hz
<b>ENVIRONMENTAL CONDITIONS</b>	20deg°C, 60%RH 960hPa	<b>TESTED BY</b>	Rex Huang

<b>AFC FREQUENCY ERROR VS. VOLTAGE</b>		
<b>VOLTAGE (Volts)</b>	<b>FREQUENCY (MHz)</b>	<b>FREQUENCY DRIFT (ppm)</b>
138	2600.14	0.005308
120	2600.12	0.004615
102	2600.10	0.003923

<b>AFC FREQUENCY ERROR VS. TEMP.</b>		
<b>TEMP. (°C)</b>	<b>FREQUENCY (MHz)</b>	<b>FREQUENCY DRIFT (ppm)</b>
60	2600.12	0.004615
50	2600.12	0.004615
40	2600.12	0.004615
30	2600.12	0.004615
20	2600.12	0.004615
10	2600.12	0.004615
0	2600.12	0.004615
-10	2600.12	0.004615
-20	2600.12	0.004615
-30	2600.12	0.004615

### 4.3 EMISSION BANDWIDTH MEASUREMENT

#### 4.3.1 LIMITS OF EMISSION BANDWIDTH MEASUREMENT

According to FCC 27.53(m)(6) specified that emission bandwidth is defined as the width of the signal between two points, one below the carrier center frequency and one above the carrier center frequency, outside of which all emissions are attenuated at least 26dB below the transmitter power.

#### 4.3.2 TEST INSTRUMENTS

Description & Manufacturer	Model No.	Serial No.	CALIBRATED DATE	CALIBRATED UNTIL
Agilent Spectrum Analyzer	E4440A	MY46185282	Jun. 15, 2008	Jun. 14, 2009
HUBER+SUHNER	SUCOFLEX104	231115/4	May 30, 2008	May 29, 2009
JFW 10dB attenuation	50HF-010-SMA	N/A	N/A	N/A

**NOTE:** The calibration interval of the above test instruments is 12 months and the calibrations are traceable to NML/ROC and NIST/USA.

#### 4.3.3 TEST SETUP

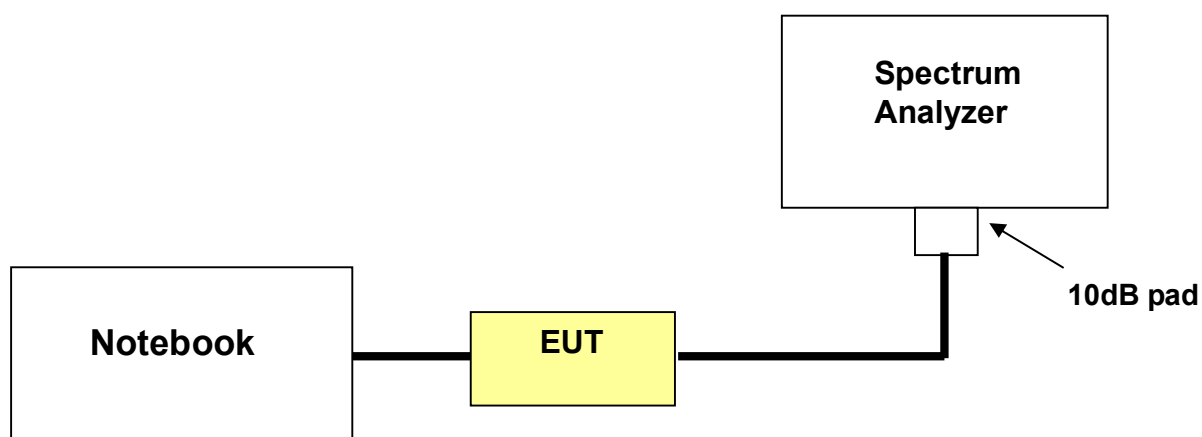

#### 4.3.4 TEST PROCEDURES

- a. The Notebook controlled EUT to export rated output power under transmission mode and specific channel frequency. The bandwidth of the fundamental frequency was measured by spectrum analyzer with 100kHz RBW and 300kHz VBW. The 26dB bandwidth is defined as the total spectrum the power of which is higher than peak power minus 26dB.



A D T

### 4.3.5 TEST RESULTS

#### CHANNEL BANDWIDTH: 5MHz

FREQUENCY (MHz)	-26 dBc BANDWIDTH (MHz)
2502.5	4.79
2600	4.78
2687.5	4.93

#### LOW CHANNEL

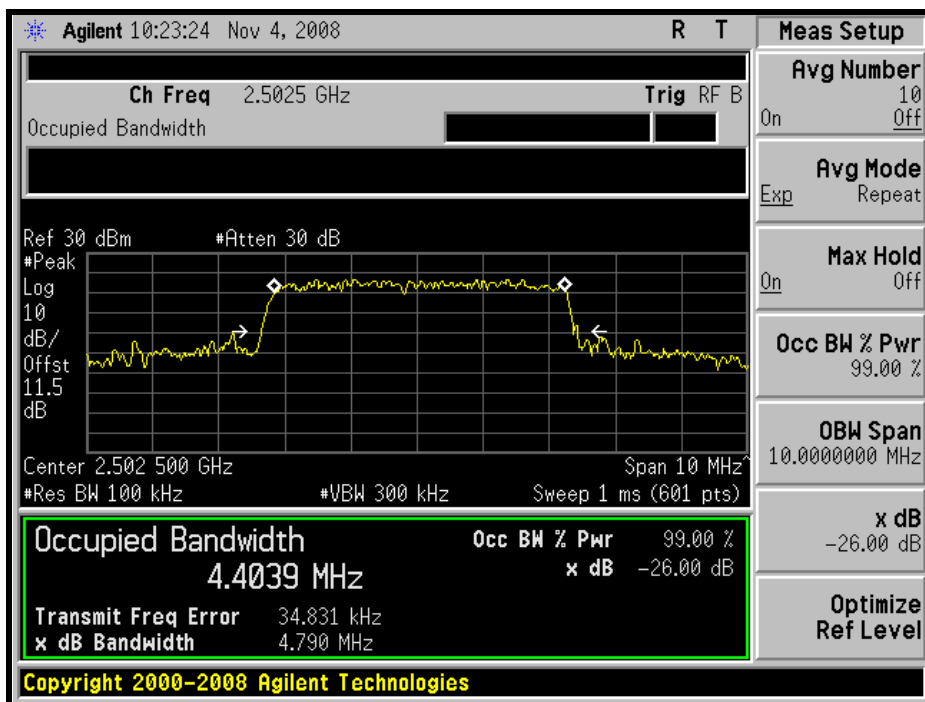



A D T

### MIDDLE CHANNEL

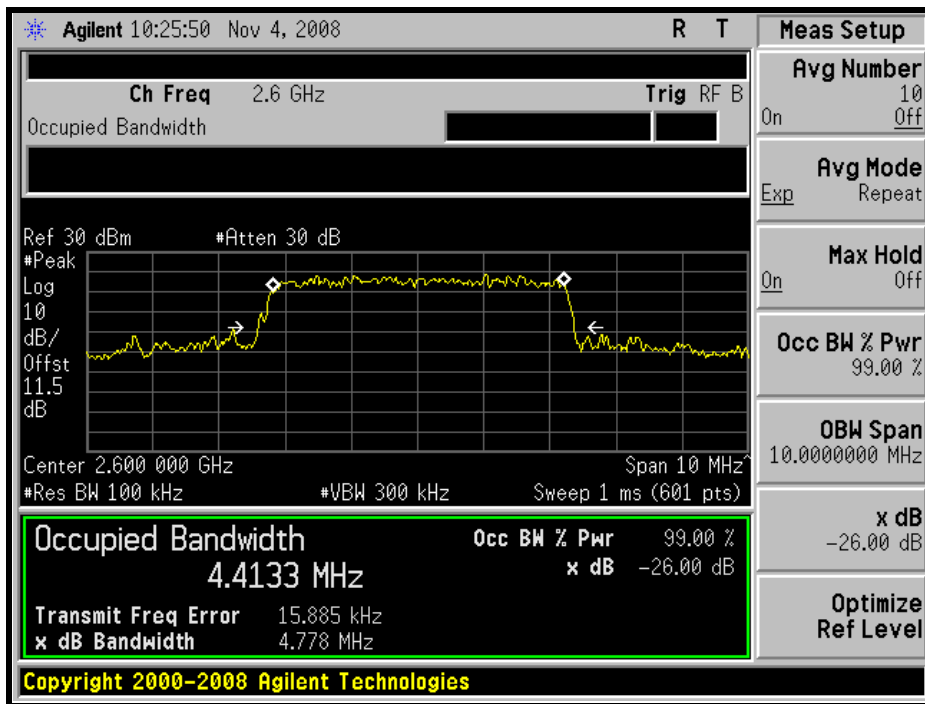

### HIGH CHANNEL

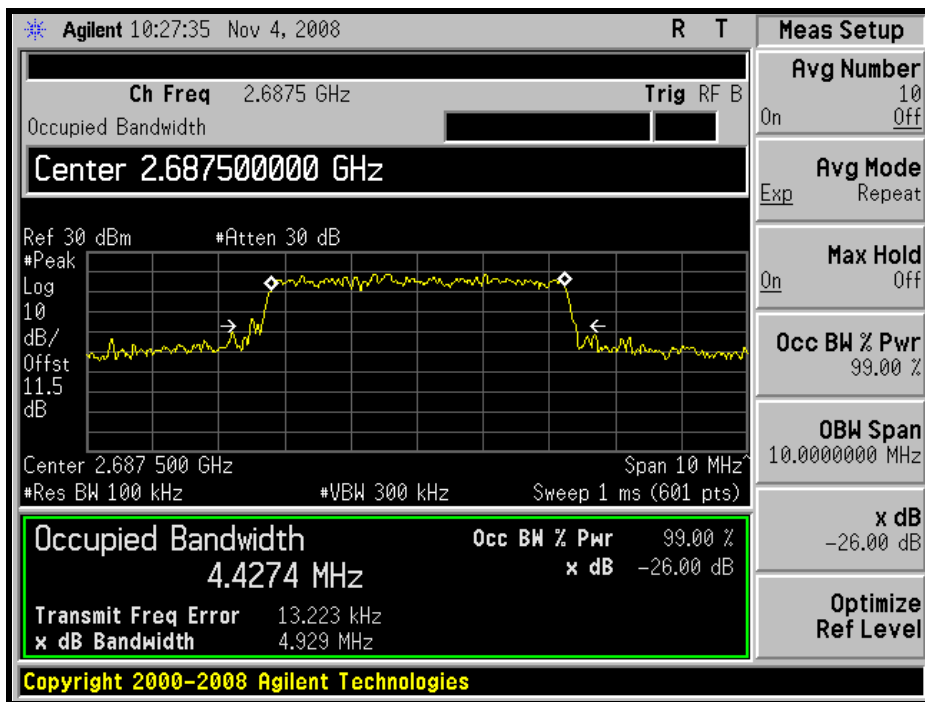





A D T

### CHANNEL BANDWIDTH: 10MHz

FREQUENCY (MHz)	-26 dBc BANDWIDTH (MHz)
2505	10.00
2600	9.67
2685	9.79

### LOW CHANNEL

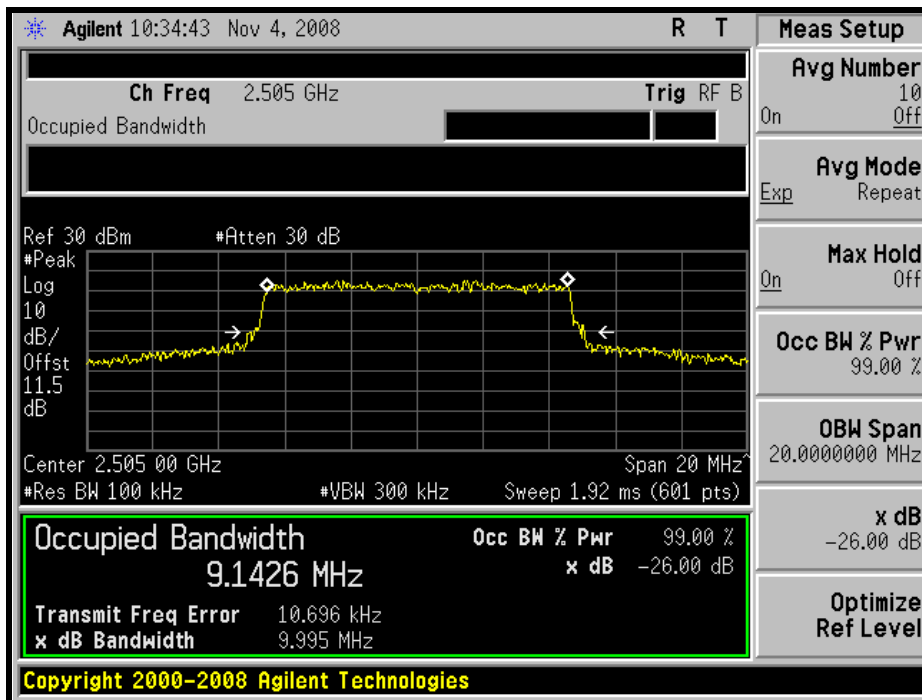



A D T

### MIDDLE CHANNEL

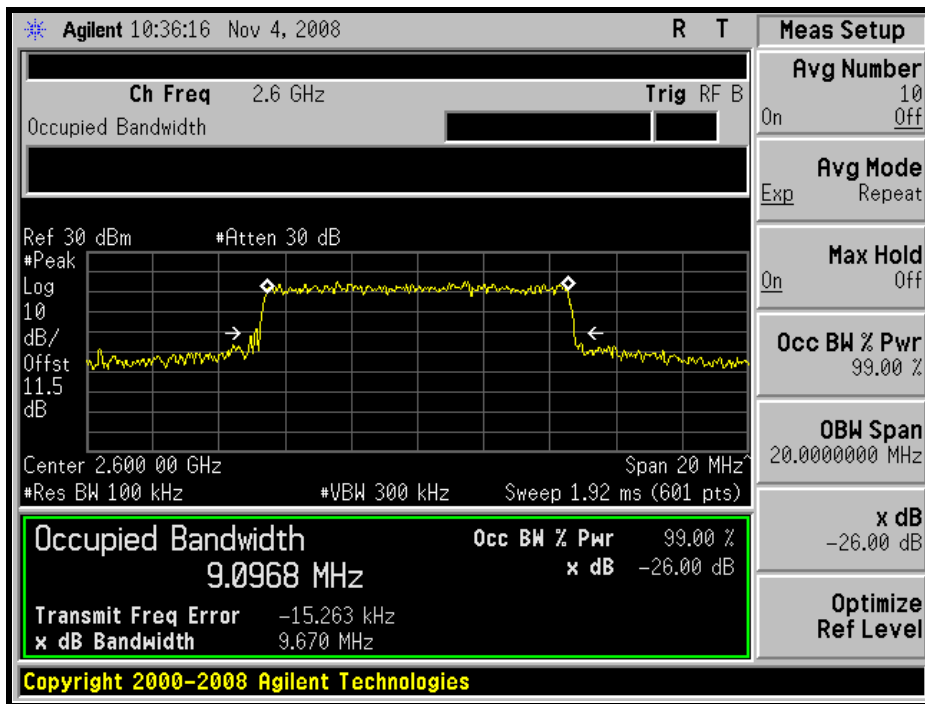

### HIGH CHANNEL

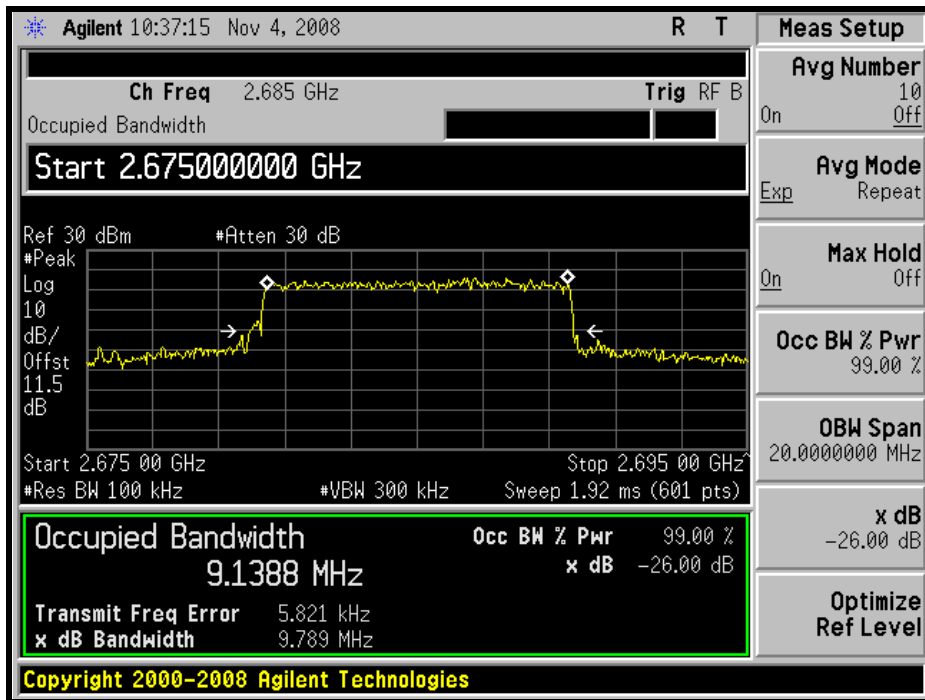

#### 4.4 CHANNEL EDGE MEASUREMENT

##### 4.4.1 LIMITS OF CHANNEL EDGE MEASUREMENT

According to FCC 27.53(m)(4) specified that power of any emission outside of the channel edge must be attenuated below the transmitting power (P) by a factor of at least  $43 + 10 \log(P)$  dB and  $55 + 10 \log(P)$  dB at 5.5 MHz from the channel edges. In the 1MHz bands immediately outside and adjacent to the frequency block a resolution bandwidth of at least one percent of the emission bandwidth of the fundamental emission of the transmitter may be employed.

##### 4.4.2 TEST INSTRUMENTS

Description & Manufacturer	Model No.	Serial No.	CALIBRATED DATE	CALIBRATED UNTIL
Agilent Spectrum Analyzer	E4440A	MY46185282	Jun. 15, 2008	Jun. 14, 2009
HUBER+SUHNER	SUCOFLEX104	231115/4	May 30, 2008	May 29, 2009
JFW 10dB attenuation	50HF-010-SMA	N/A	N/A	N/A

**NOTE:** The calibration interval of the above test instruments is 12 months and the calibrations are traceable to NML/ROC and NIST/USA.

##### 4.4.3 TEST SETUP

Same as Item 4.3.3

#### 4.4.4 TEST PROCEDURES

- a. The EUT was set up for the rated peak power . The power was measured with Spectrum Analyzer. All measurements were done at 3 channels: low, middle and high operational frequency range.
- b. For Channel bandwidth: 5 MHz:  
The center frequency of spectrum is the band edge frequency and span is 20MHz. RB of the spectrum is 51kHz and VB of the spectrum is 150kHz.
- c. For Channel bandwidth: 10 MHz:  
The center frequency of spectrum is the band edge frequency and span is 30MHz. RB of the spectrum is 100kHz and VB of the spectrum is 300kHz.
- d. Record the max trace plot into the test report.

#### 4.4.5 EUT OPERATING CONDITION

Same as item 4.1.5



A D T

### 4.4.6 TEST RESULTS

#### CHANNEL BANDWIDTH: 5MHz

#### LOW CHANNEL

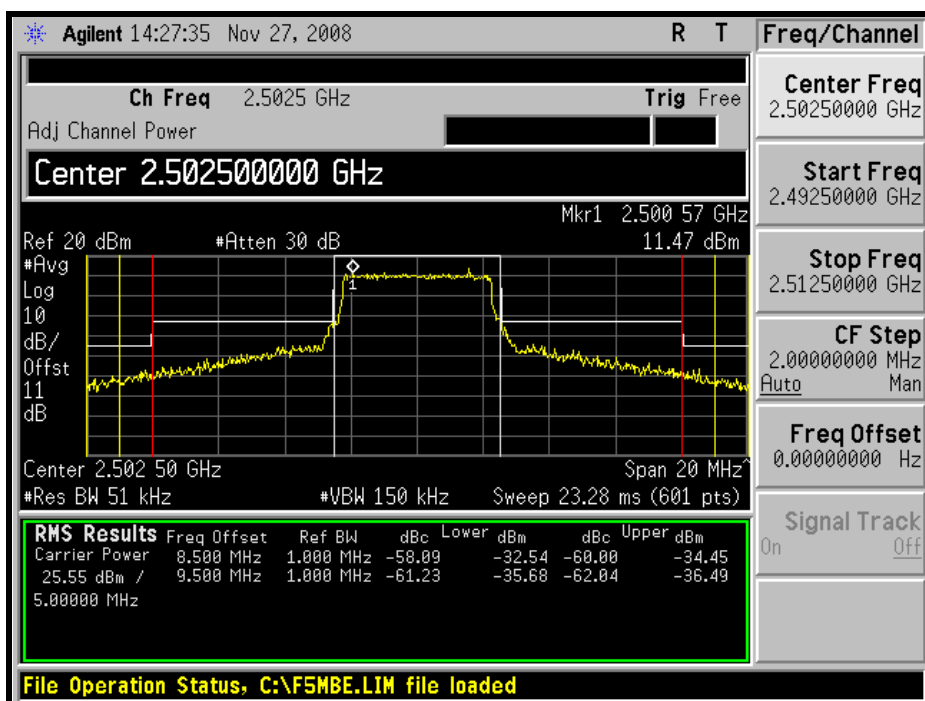
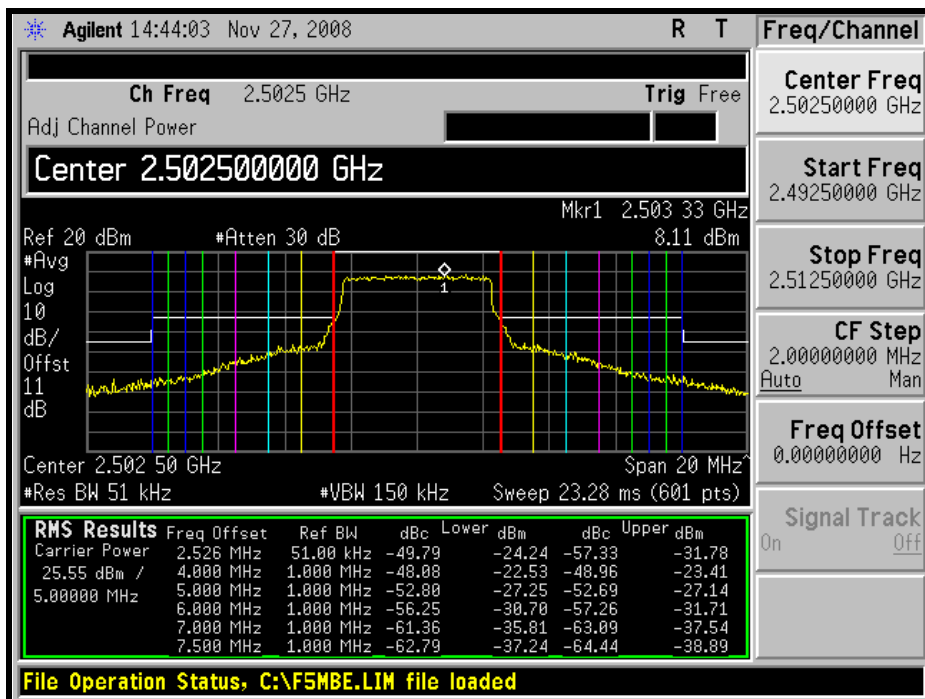



A D T

### MIDDLE CHANNEL

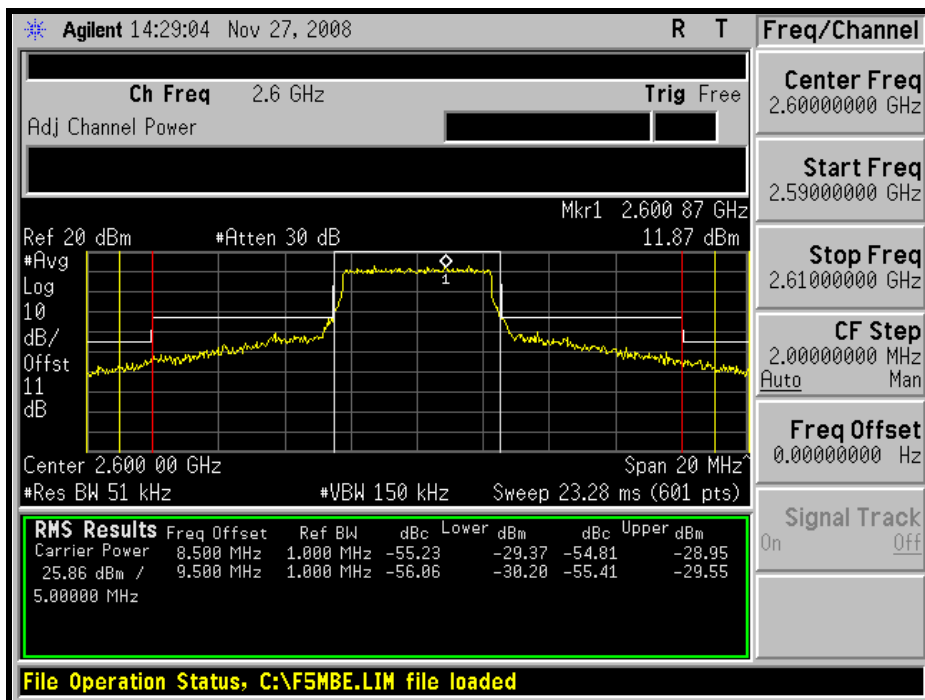
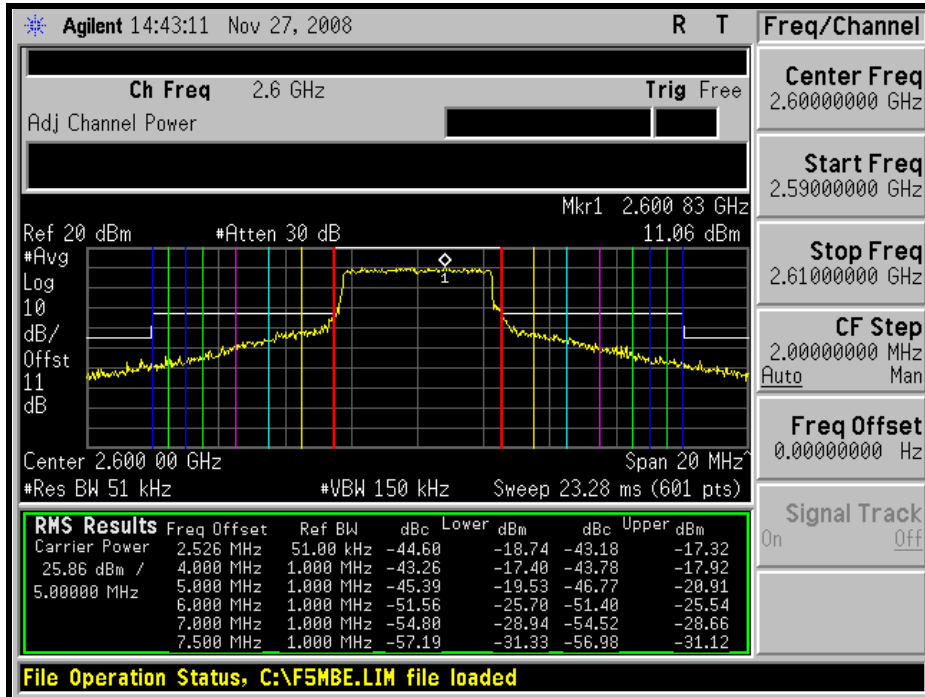



A D T

### HIGH CHANNEL

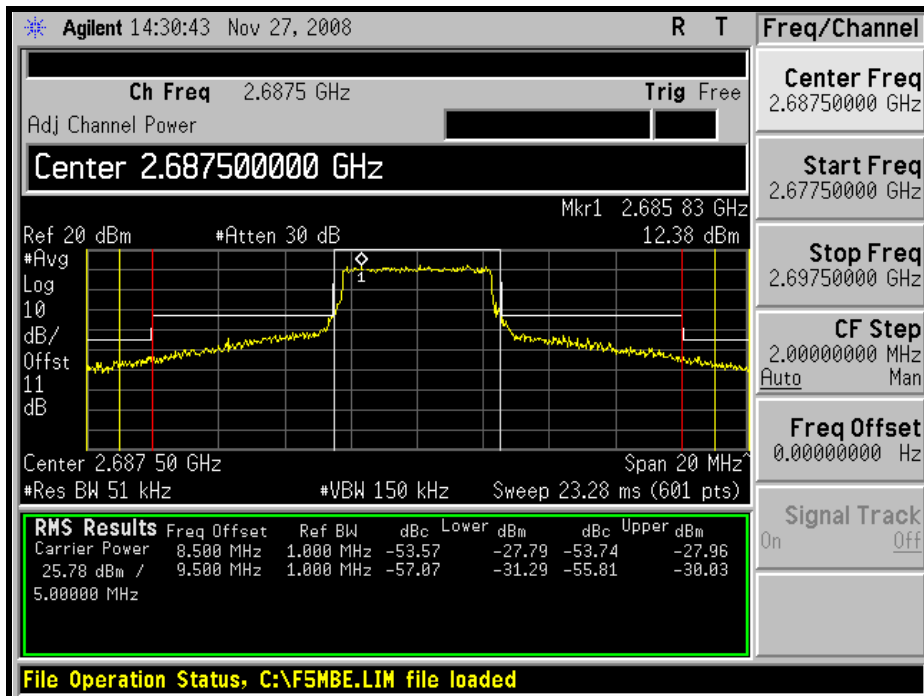
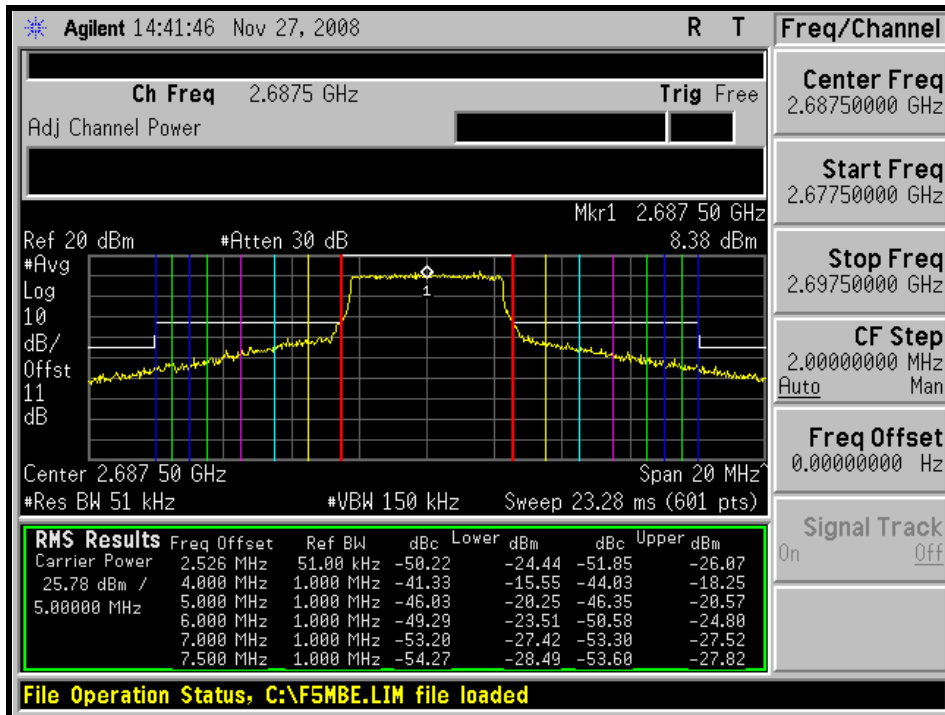



A D T

# CHANNEL BANDWIDTH: 10MHz

## LOW CHANNEL

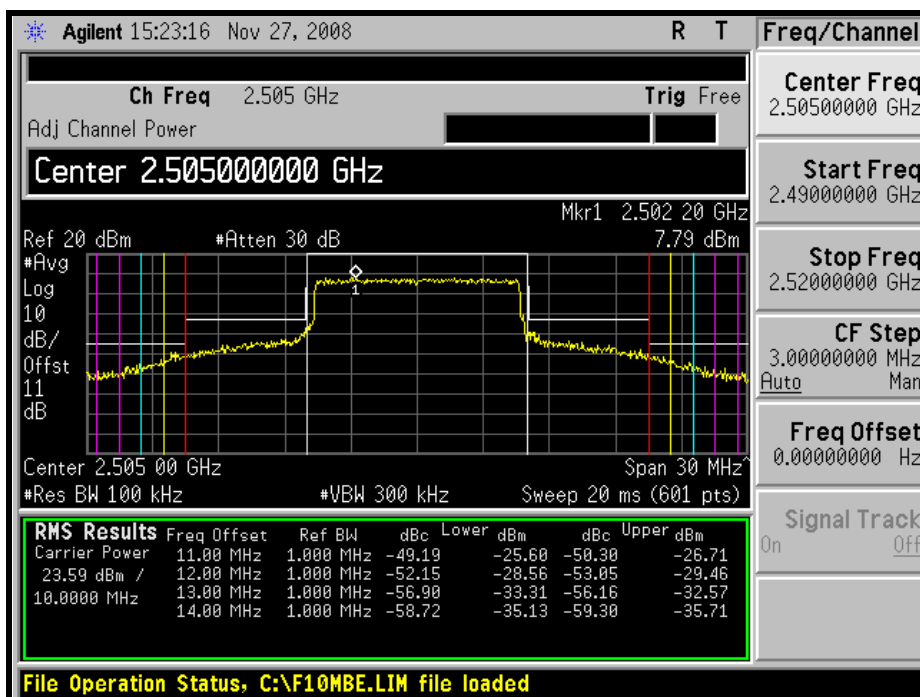
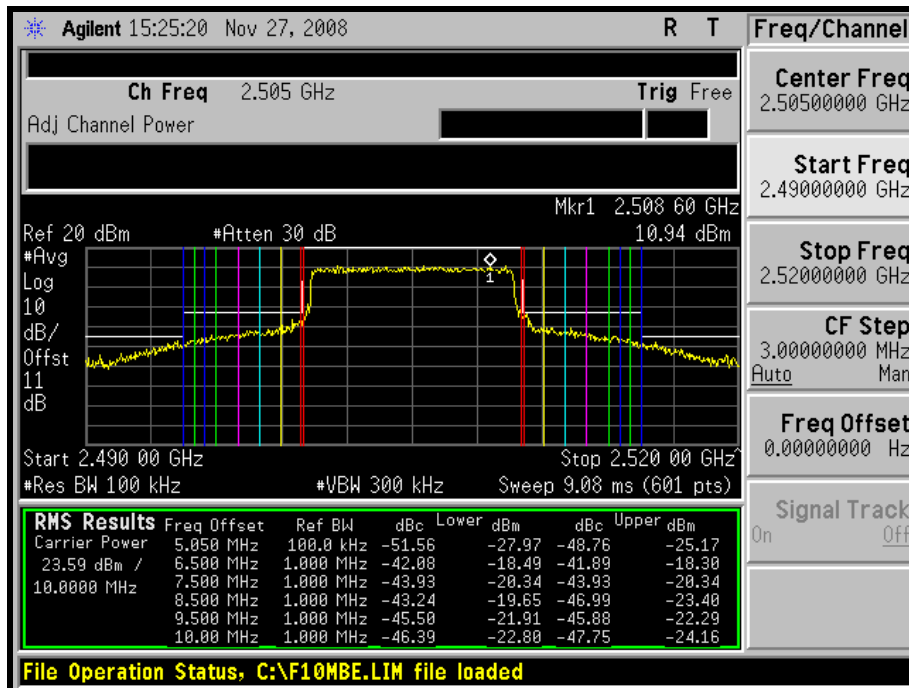





A D T

MIDDLE CHANNEL

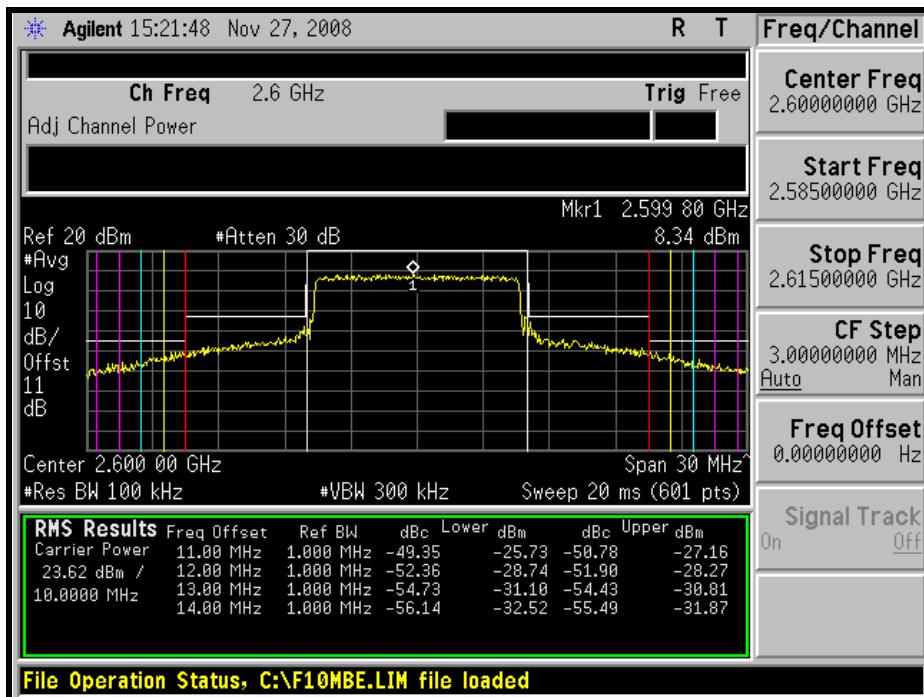
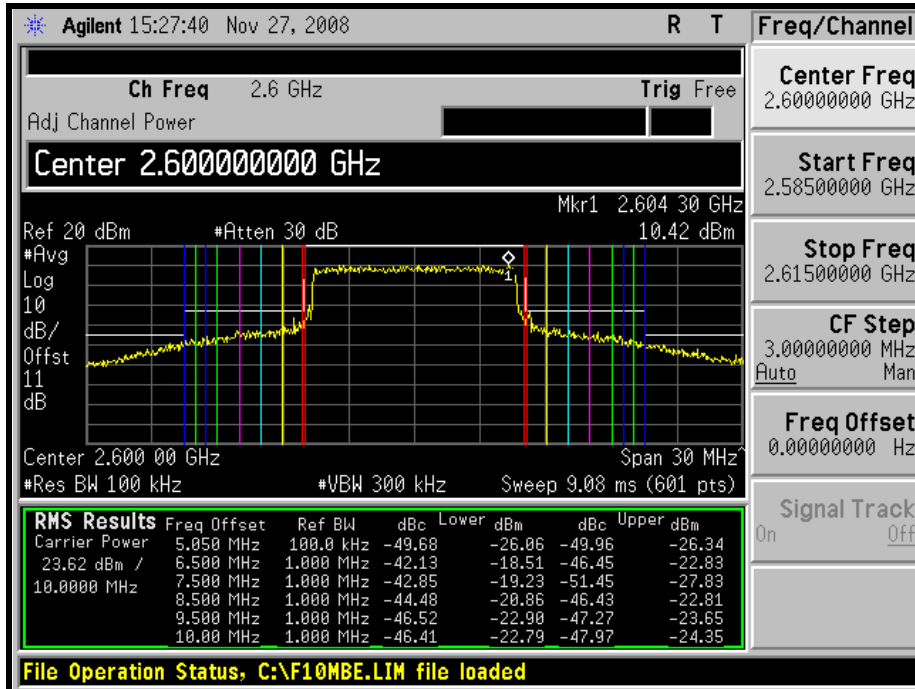



A D T

### HIGH CHANNEL

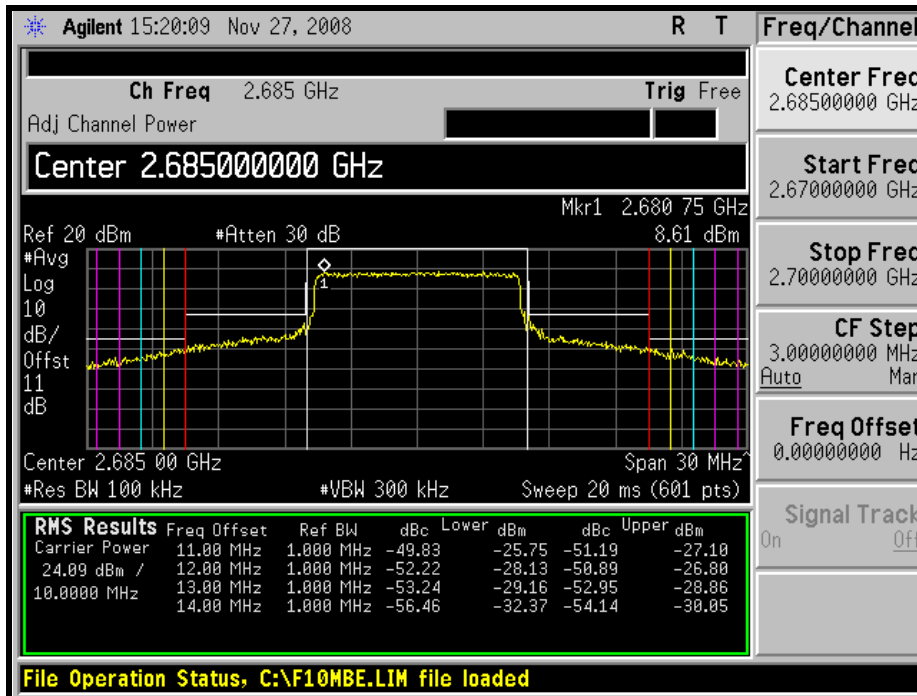
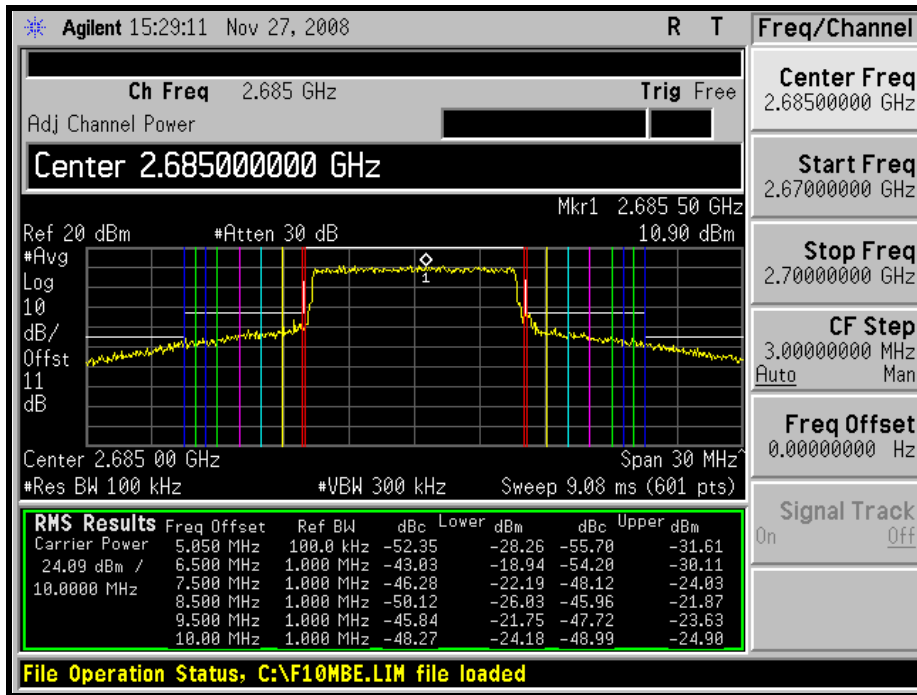



## 4.5 CONDUCTED SPURIOUS EMISSIONS

### 4.5.1 LIMITS OF CONDUCTED SPURIOUS EMISSIONS MEASUREMENT

In the FCC 27.53(m)(4), On any frequency outside a licensee's frequency block, the power of any emission shall be attenuated below the transmitter power (P) by at least  $43 + 10 \log (P)$  dB and  $55 + 10 \log (P)$  dB at 5.5 MHz from the channel edges.

### 4.5.2 TEST INSTRUMENTS

Description & Manufacturer	Model No.	Serial No.	CALIBRATED DATE	CALIBRATED UNTIL
Agilent Spectrum Analyzer	E4440A	MY46185282	Jun. 15, 2008	Jun. 14, 2009
HUBER+SUHNER	SUCOFLEX104	231115/4	May 30, 2008	May 29, 2009
JFW 10dB attenuation	50HF-010-SMA	N/A	N/A	N/A
Wainwright Instruments High Pass Filter	WHK3.1/18G-1 0SS	ZZ-010091	N/A	N/A

**NOTE:** The calibration interval of the above test instruments is 12 months and the calibrations are traceable to NML/ROC and NIST/USA.

#### 4.5.3 TEST PROCEDURE

- a. The EUT was set up for the rated peak power. The power was measured with Spectrum Analyzer. All measurements were done at 3 channels: low, middle and high operational frequency range.
- b. When the spectrum scanned from 30MHz to 3GHz, it shall be connected to the 10dB pad attenuated the carried frequency. The spectrum set RB = 1MHz, VB = 3MHz.
- c. When the spectrum scanned from 3GHz to 26.5GHz, it shall be connected to the high pass filter attenuated the carried frequency. The spectrum set RB = 1MHz, VB = 3MHz.

#### 4.5.4 TEST SETUP

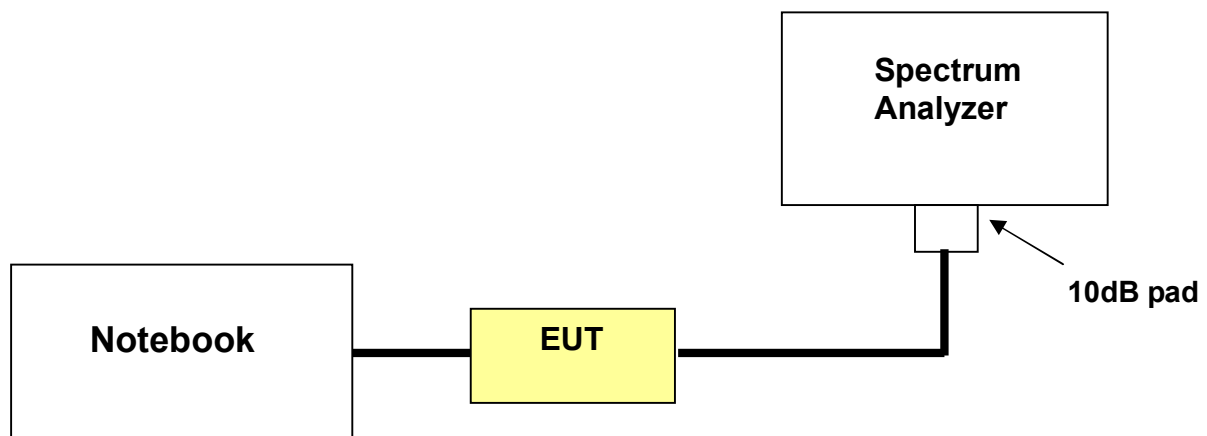

#### 4.5.5 EUT OPERATING CONDITIONS

Same as item 4.1.5



A D T

#### 4.5.6 TEST RESULTS

##### CHANNEL BANDWIDTH: 5MHz

LOW CHANNEL: 30MHz ~ 1GHz:

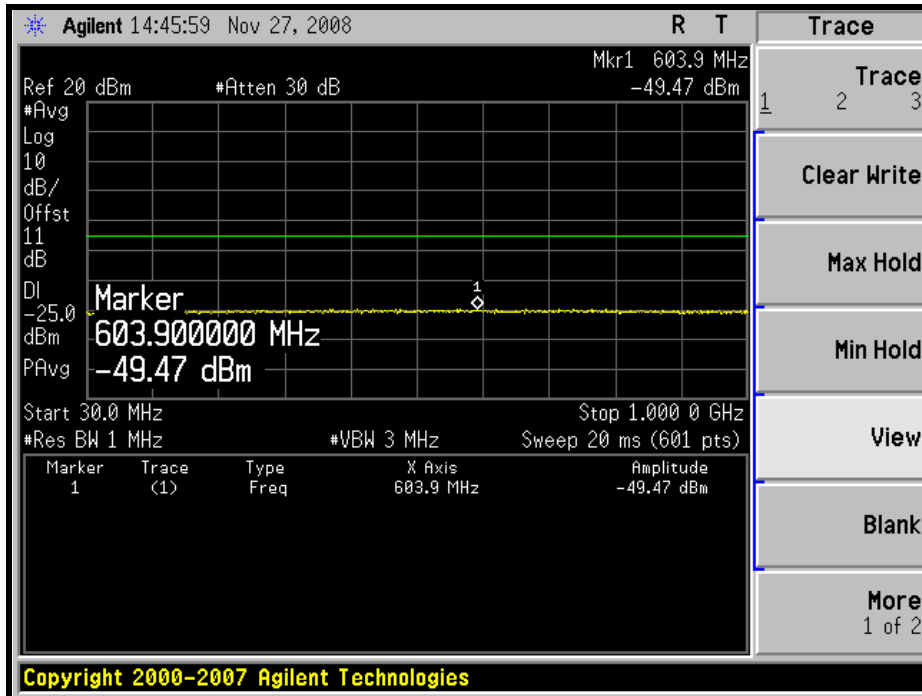

1GHz ~ 5GHz:

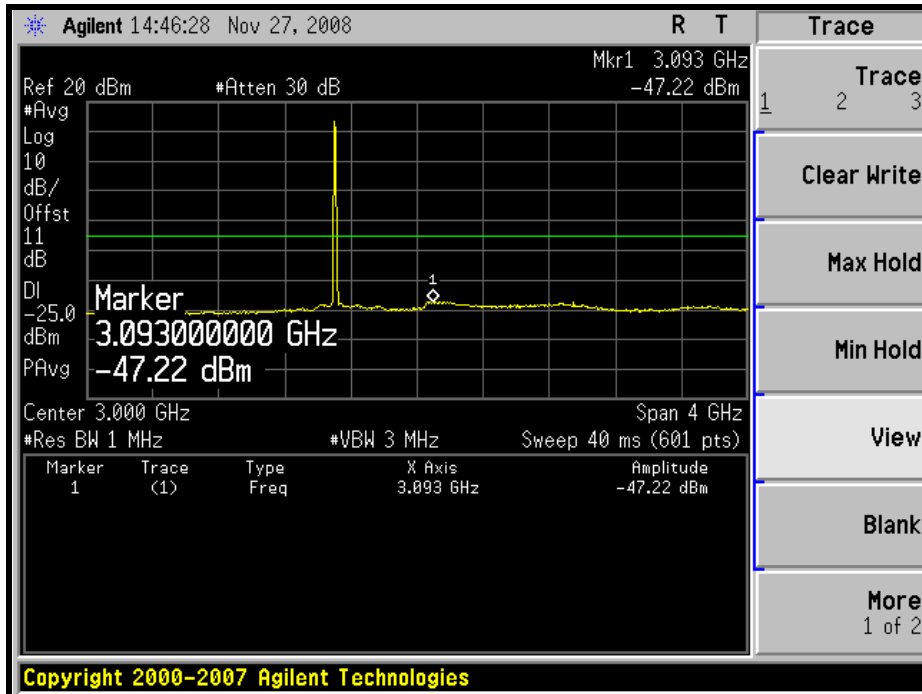



A D T

5GHz ~ 10GHz:

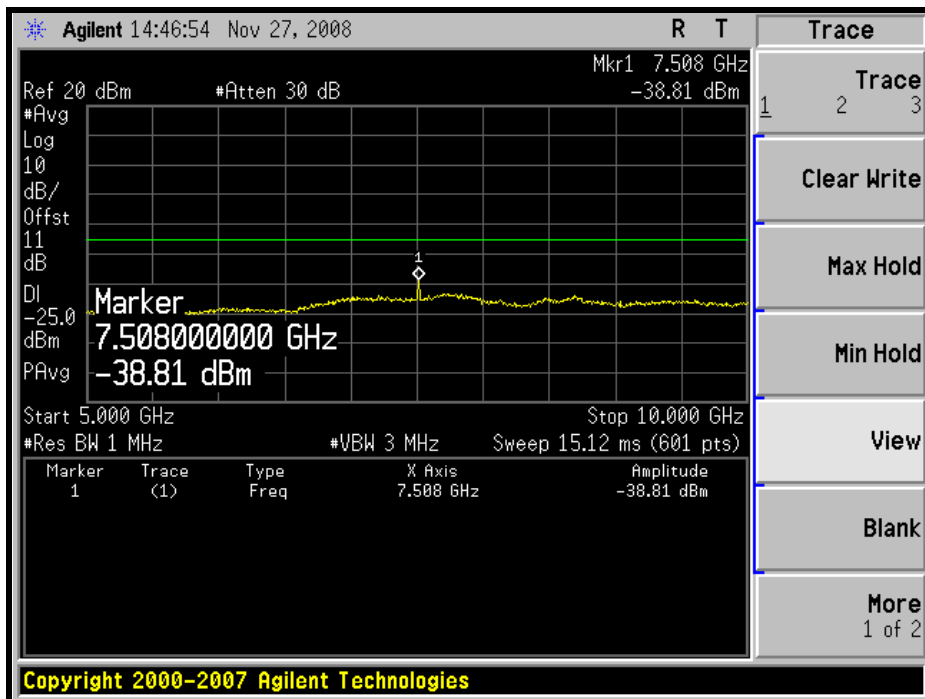

10GHz ~ 27GHz:

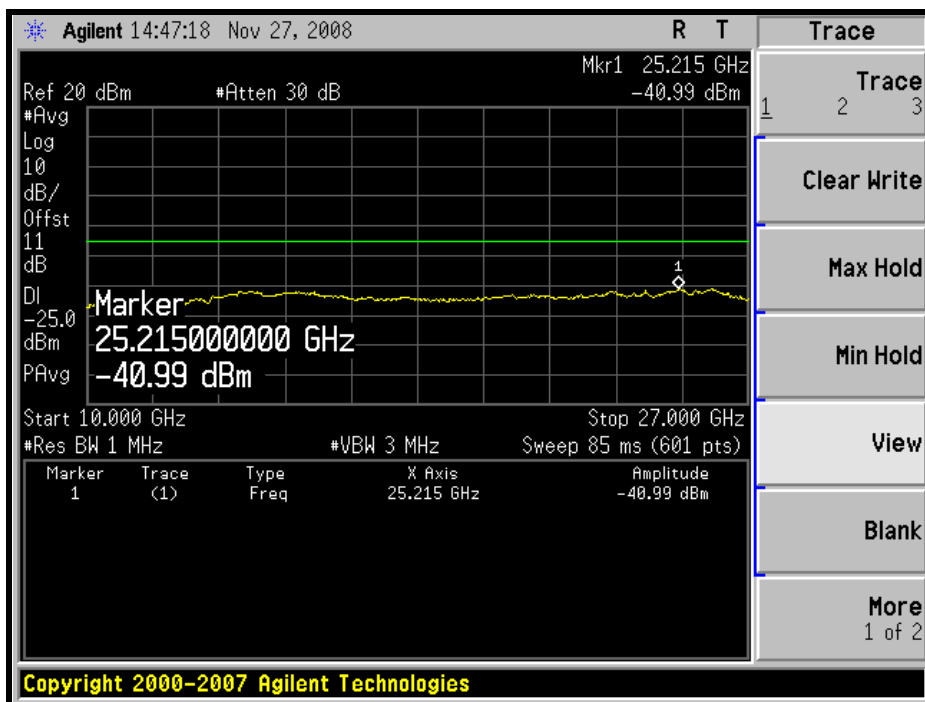



A D T

MIDDLE CHANNEL: 30MHz ~ 1GHz:

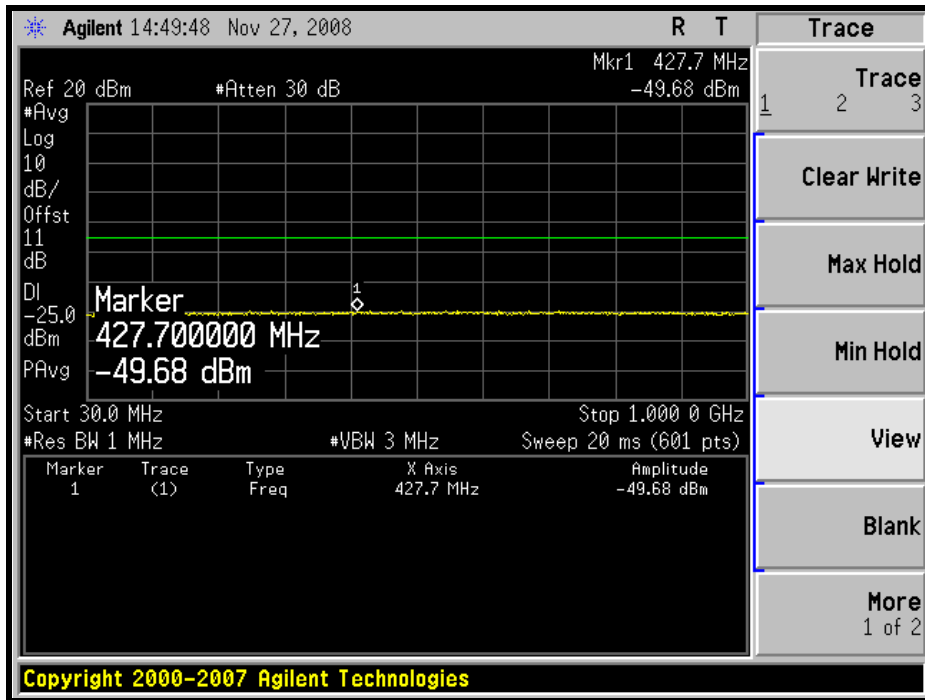

1GHz ~ 5GHz:

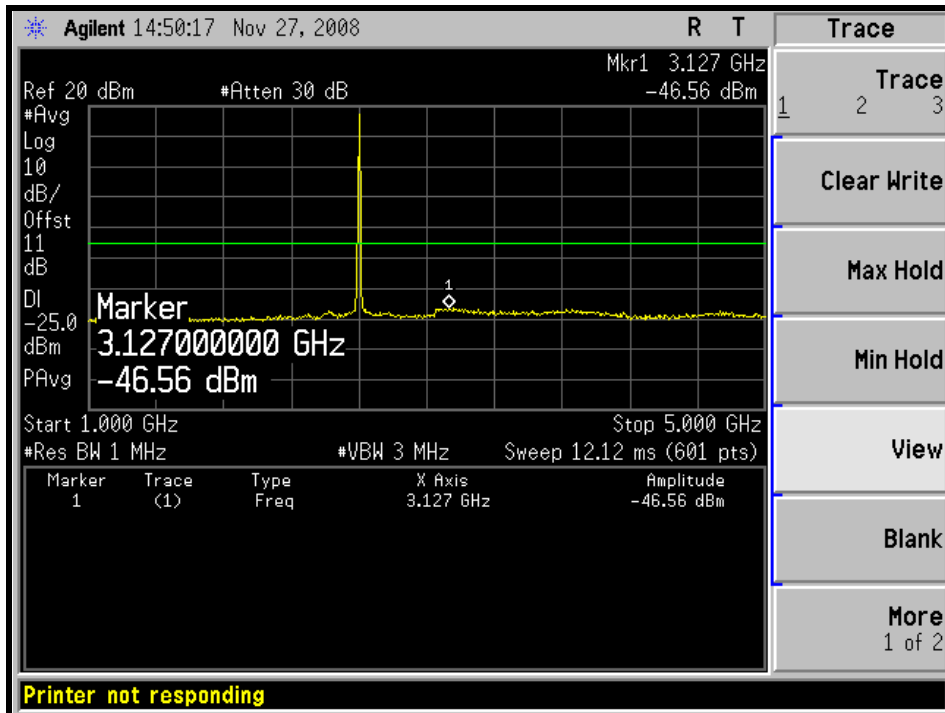



A D T

5GHz ~ 10GHz:

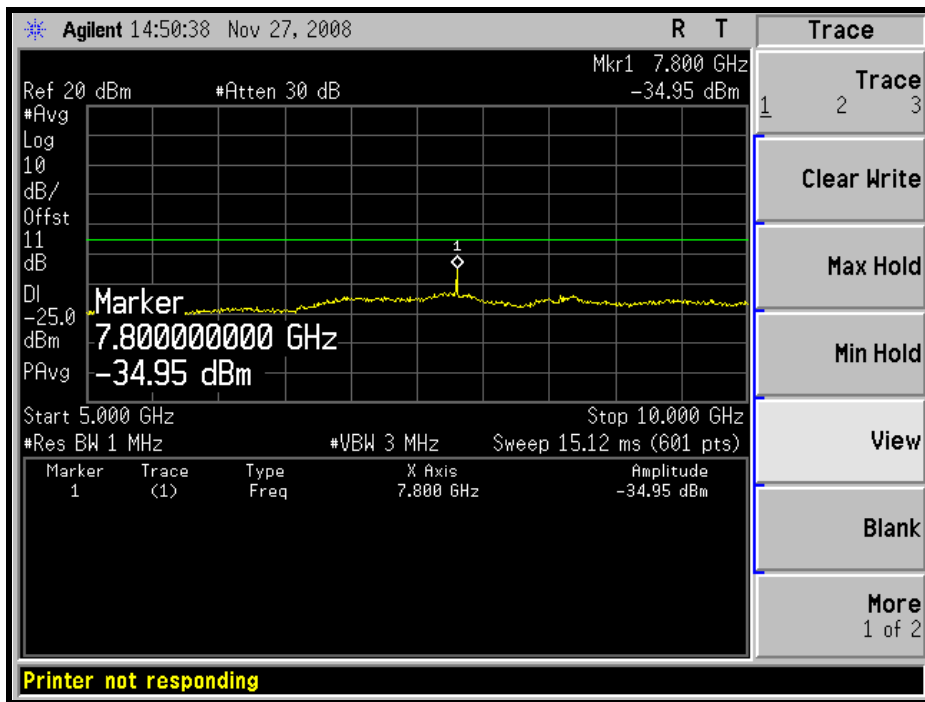

10GHz ~ 27GHz:

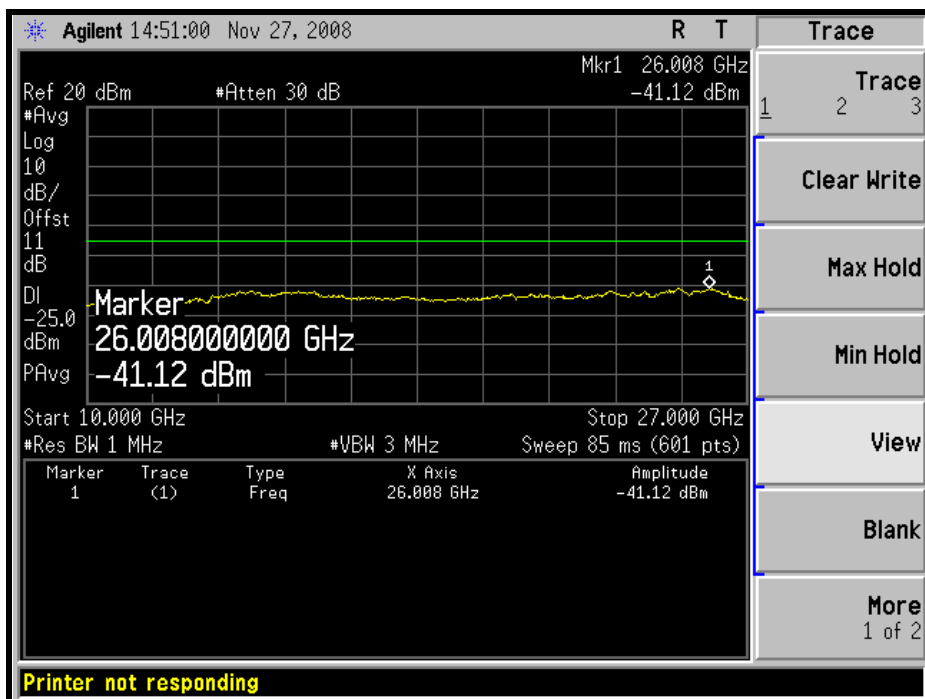





A D T

### HIGH CHANNEL: 30MHz ~ 1GHz:

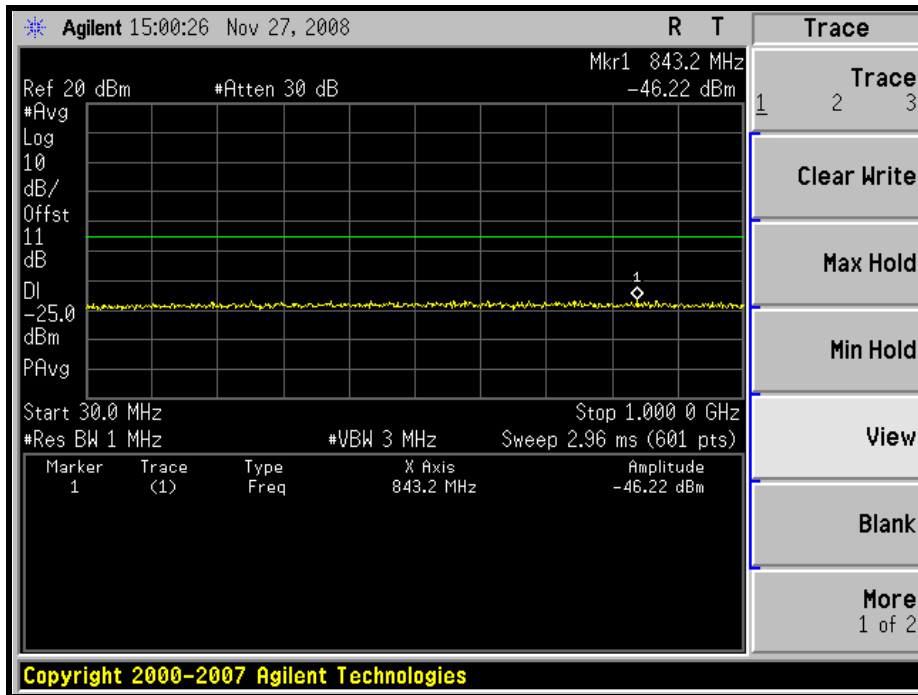

### 1GHz ~ 5GHz:

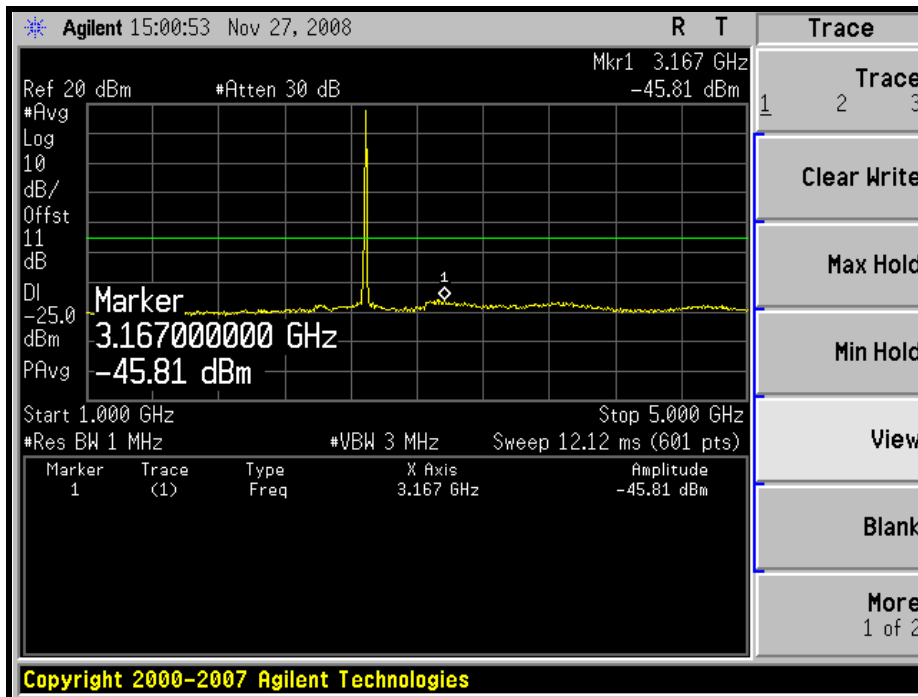



A D T

5GHz ~ 10GHz:

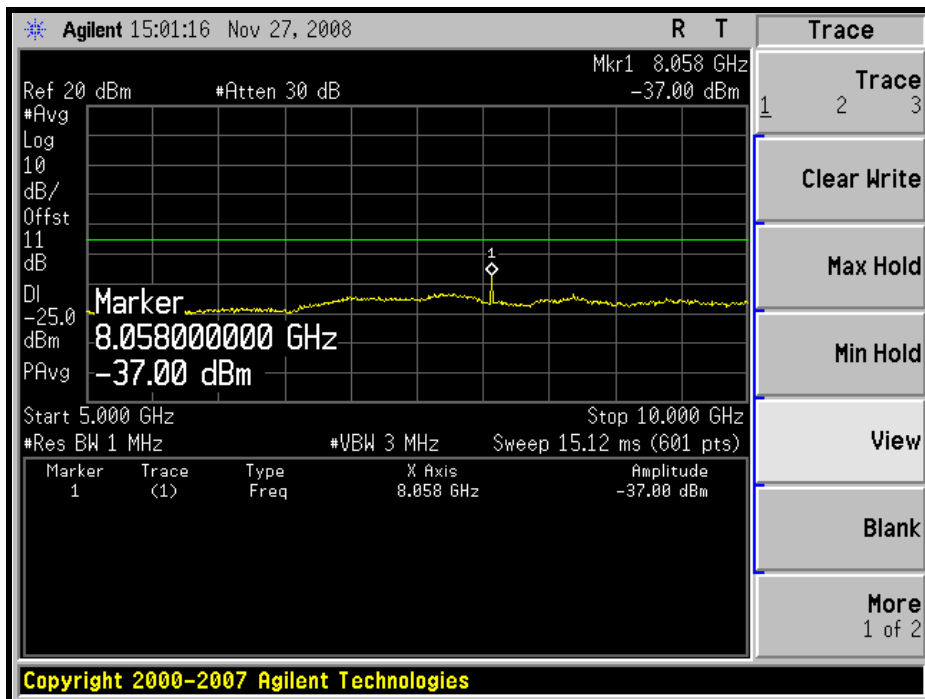

10GHz ~ 27GHz:

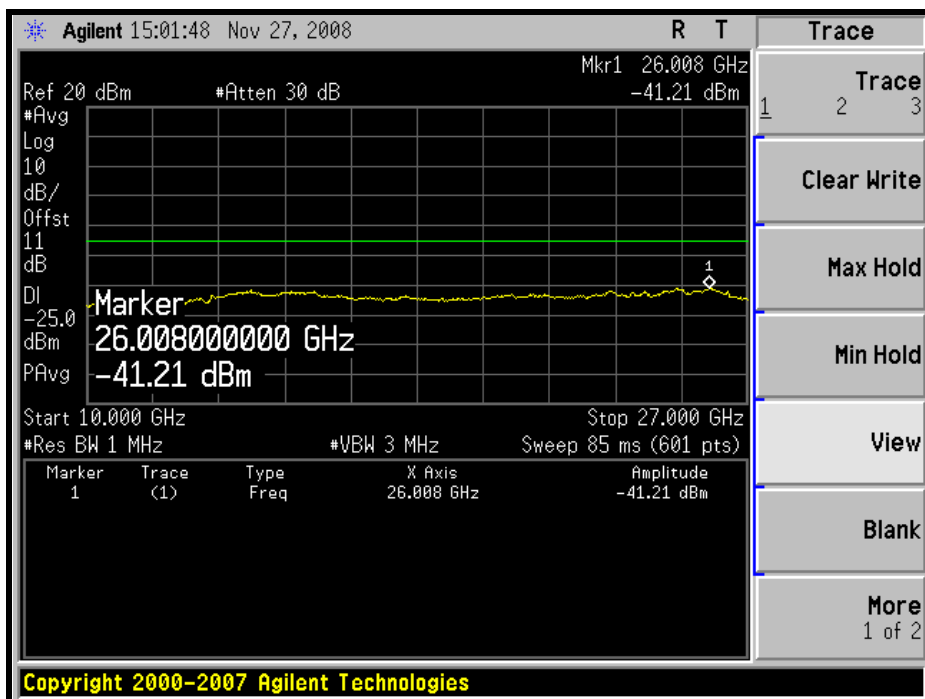



A D T

### CHANNEL BANDWIDTH: 10MHz

LOW CHANNEL: 30MHz ~ 1GHz:

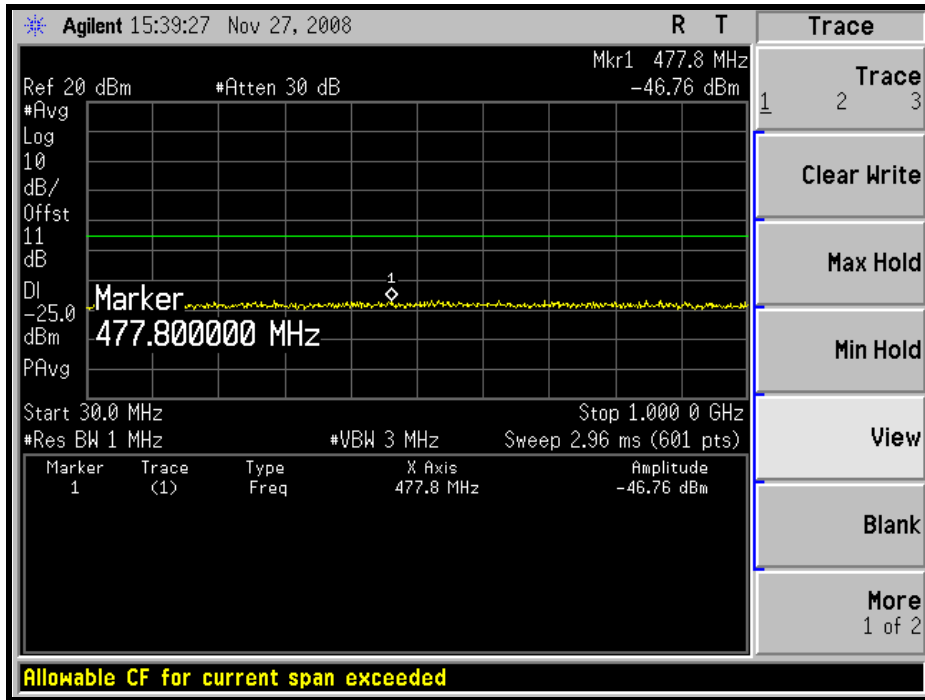

1GHz ~ 5GHz:

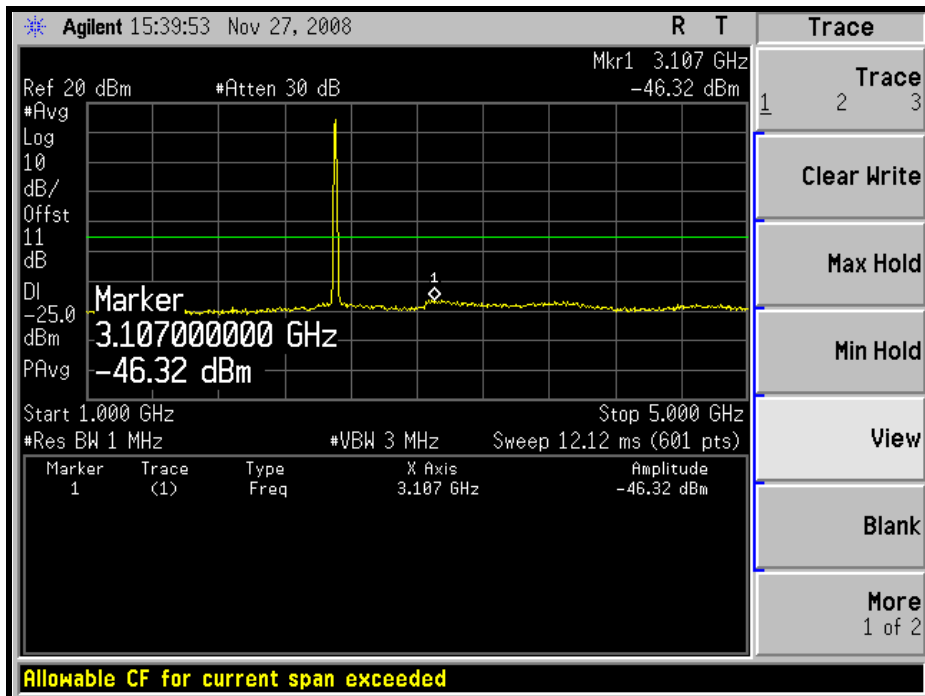



A D T

5GHz ~ 10GHz:

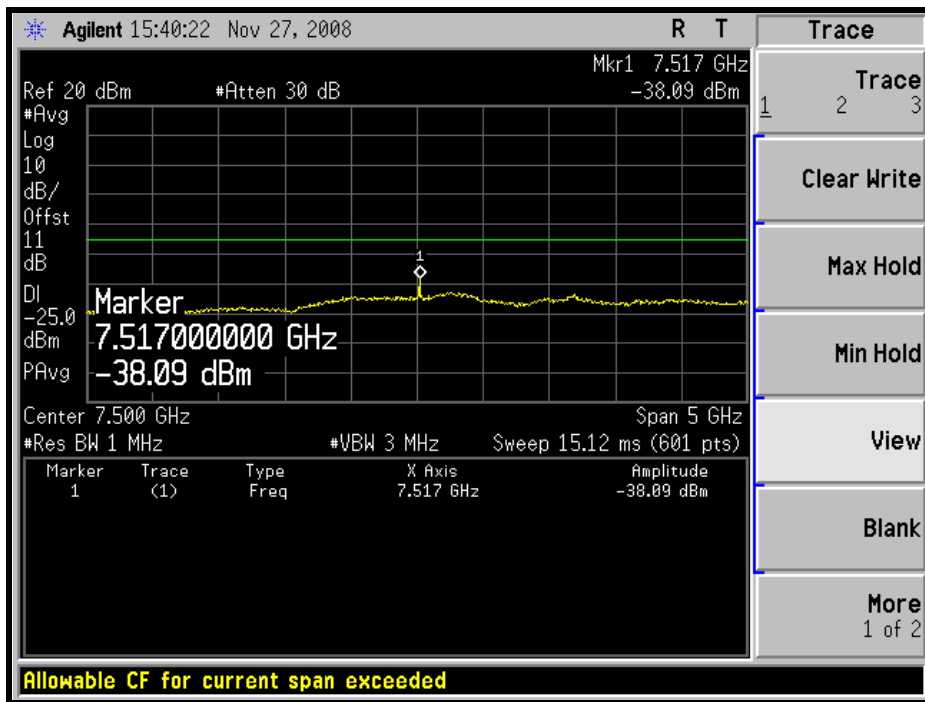

10GHz ~ 27GHz:

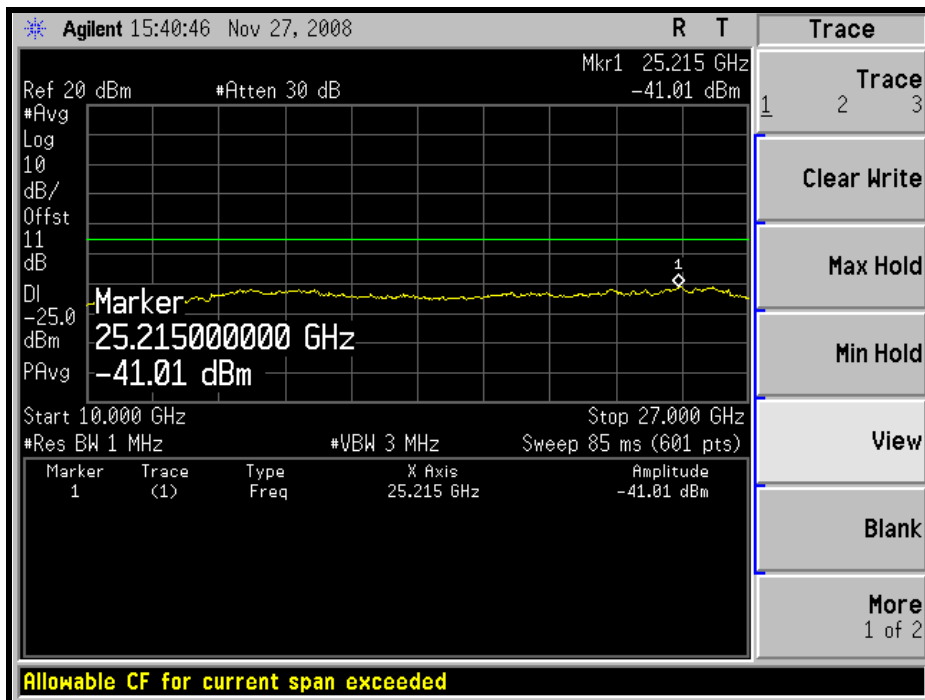



A D T

MIDDLE CHANNEL: 30MHz ~ 1GHz:

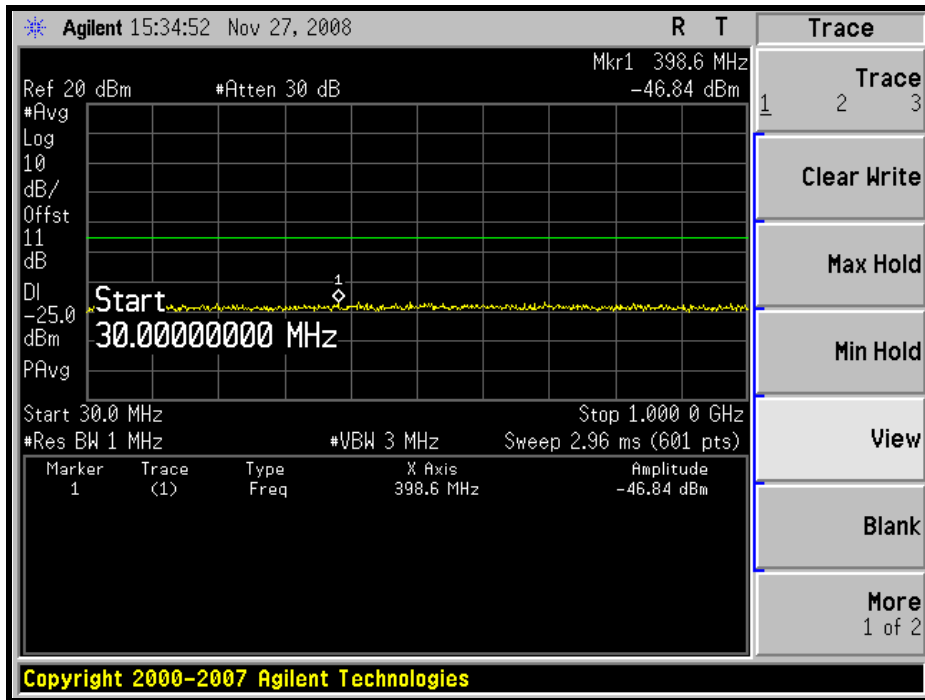

1GHz ~ 5GHz:

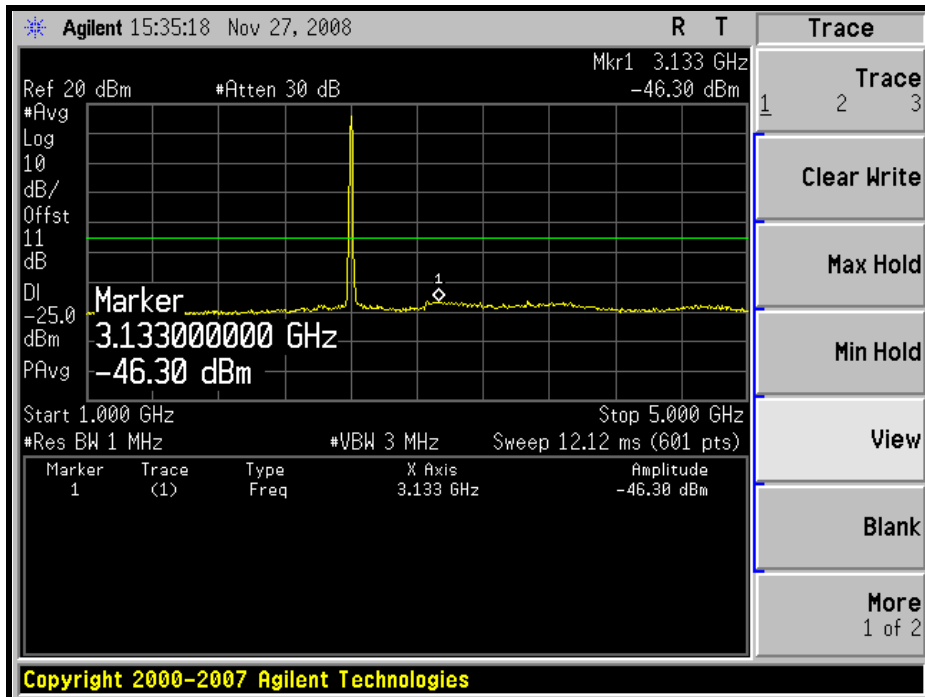



A D T

5GHz ~ 10GHz:

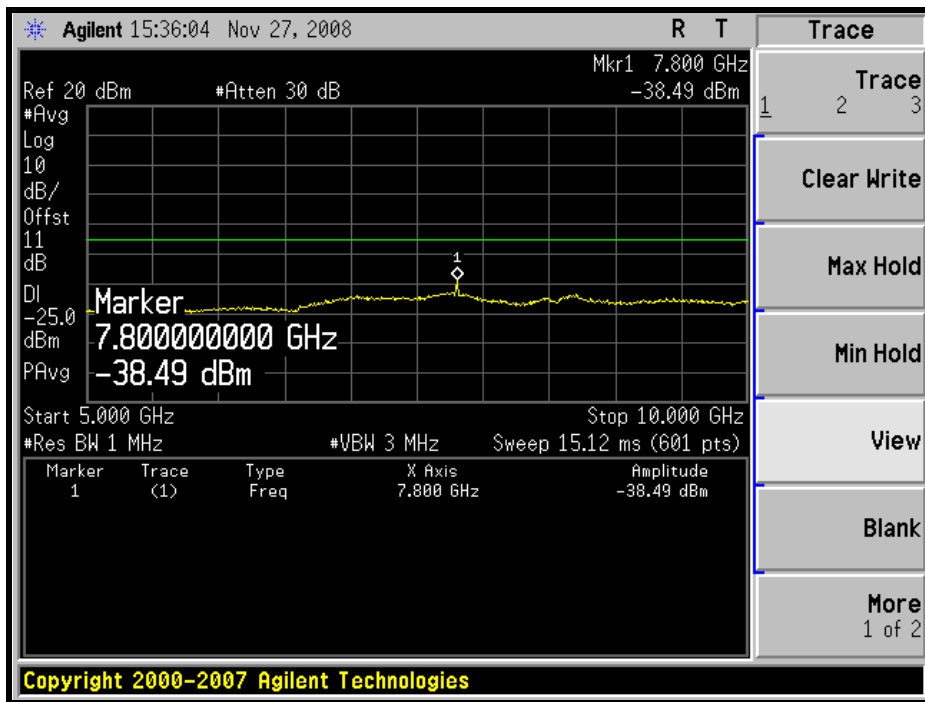

10GHz ~ 27GHz:

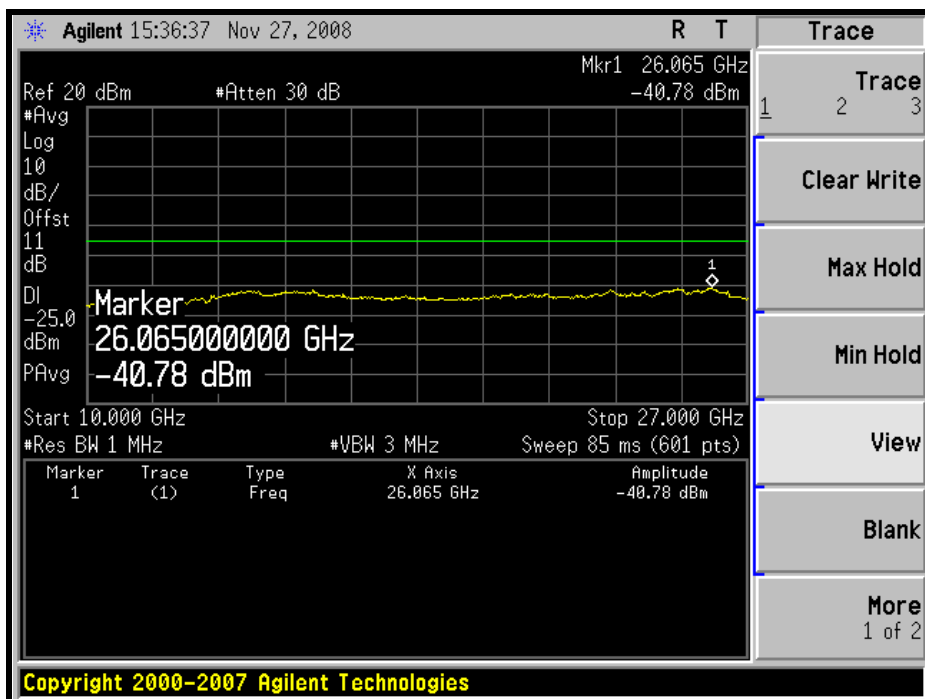



A D T

### HIGH CHANNEL: 30MHz ~ 1GHz:

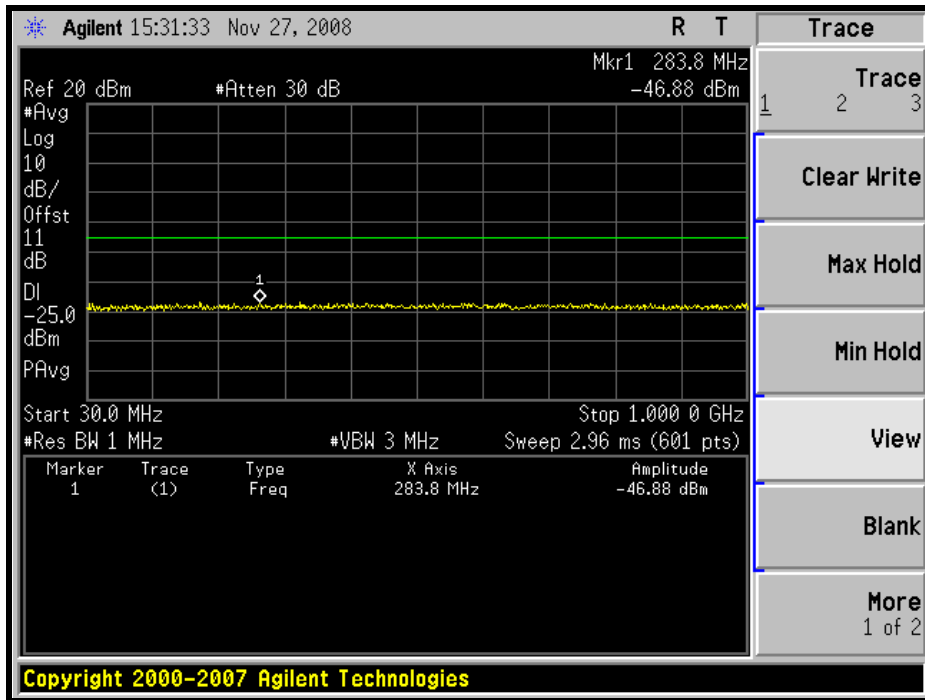

### 1GHz ~ 5GHz:

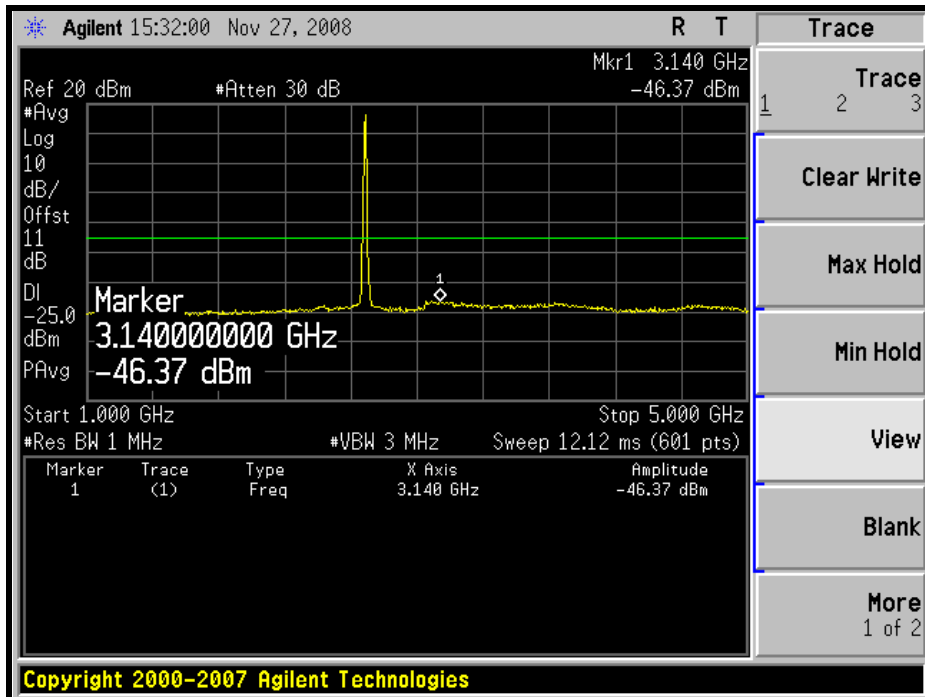



A D T

5GHz ~ 10GHz:

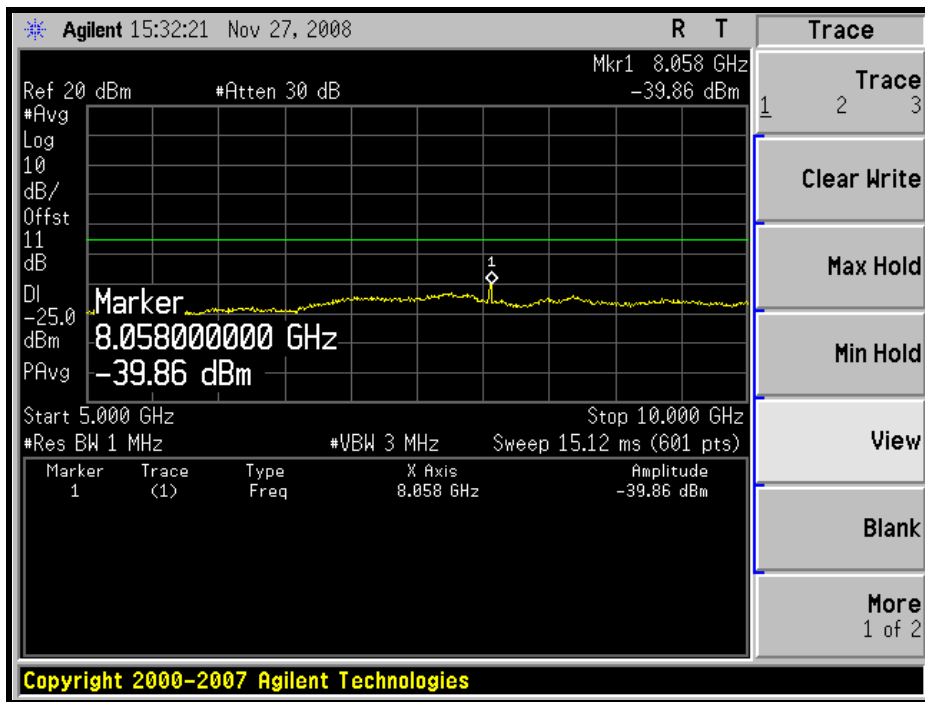

10GHz ~ 27GHz:

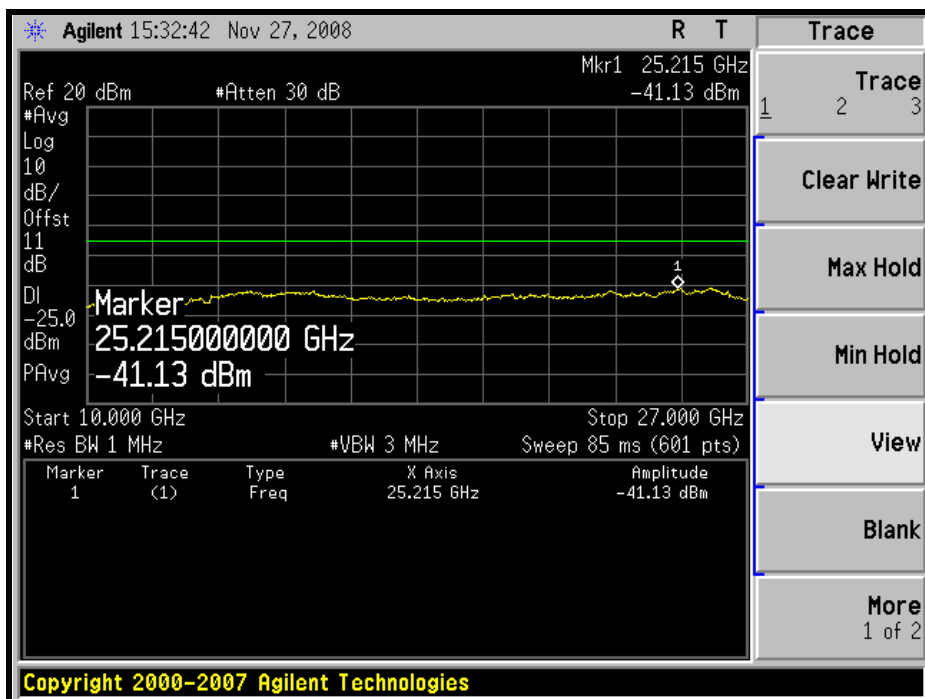





## 4.6 RADIATED EMISSION MEASUREMENT (BELOW 1GHz)

### 4.6.1 LIMITS OF RADIATED EMISSION MEASUREMENT

In the FCC 27.53(m) (4), On any frequency outside a licensee's frequency block the power of any emission shall be attenuated below the transmitter power (P) by at least  $43 + 10 \log (P)$  dB and  $55 + 10 \log (P)$  dB at 5.5 MHz from the channel edges.

### 4.6.2 TEST INSTRUMENTS

DESCRIPTION & MANUFACTURER	MODEL NO.	SERIAL NO.	CALIBRATED DATE	CALIBRATED UNTIL
ADVANTEST Spectrum Analyzer	R3271A	85060311	July 16, 2008	July 15, 2009
HP Pre_Amplifier	8449B	3008A01922	Sep. 25, 2008	Sep. 24, 2009
ROHDE & SCHWARZ Test Receiver	ESCS30	847124/029	Feb. 29, 2008	Feb. 28, 2009
SCHWARZBECK TRILOG Broadband Antenna	VULB 9168	138	April 30, 2008	April 29, 2009
Schwarzbeck Horn_Antenna	BBHA9120	D124	Dec. 09, 2008	Dec. 08, 2009
Schwarzbeck Horn_Antenna	BBHA 9170	BBHA9170153	Jan. 22, 2009	Jan. 21, 2010
RF Switches	EMH-011	08009	Oct. 07, 2008	Oct. 06, 2009
RF CABLE (Chaintek)	SF102	22054-2	Dec. 07, 2008	Dec. 06, 2009
RF Cable	8DFB	STCCAB-30M-1GHz	Oct. 07, 2008	Oct. 06, 2009
Software	ADT_Radiated_V7.6.15.9.2	NA	NA	NA
CT Antenna Tower & Turn Table	NA	NA	NA	NA
Agilent Signal generator	E8241A	US42110446	Oct. 28, 2008	Oct. 27, 2009

Note: 1. The calibration interval of the above test instruments is 12 months and the calibrations are traceable to NML/ROC and NIST/USA.

2. The horn antenna, HP preamplifier (model: 8449B) and Spectrum Analyzer (model: R3271A) are used only for the measurement of emission frequency above 1GHz if tested.

3. The test was performed in Open Site No. C.

4. The FCC Site Registration No. is 656396.

5. The VCCI Site Registration No. is R-1626.

6. The CANADA Site Registration No. is IC 7450G-3.

#### 4.6.3 TEST PROCEDURES

- a. The EUT was placed on the top of a rotating table 0.8 meters above the ground. The table was rotated 360 degrees to determine the position of the highest radiation.
- b. The EUT was set 3 meters away from the receiving antenna, which was mounted on antenna tower and its position at 0.8 m above the ground.
- c. For each suspected emission, the EUT was arranged to its worst case and the rotatable table was turned from 0 degrees to 360 degrees to find the maximum reading and recorded the value.
- d. The EUT is replaced by a horn antenna connected to a signal generator tuned to the frequency of emission.
- e. The signal generator level has to be adjusted to have the same emission nature.
- f. The radiated power can be calculated via the factor and antenna gain.
- g. Repeat step a ~ f for horizontal polarization.

**NOTE:** The resolution bandwidth of spectrum analyzer is 1MHz and the video bandwidth is 3MHz.

#### 4.6.4 DEVIATION FROM TEST STANDARD

No deviation

#### 4.6.5 TEST SETUP

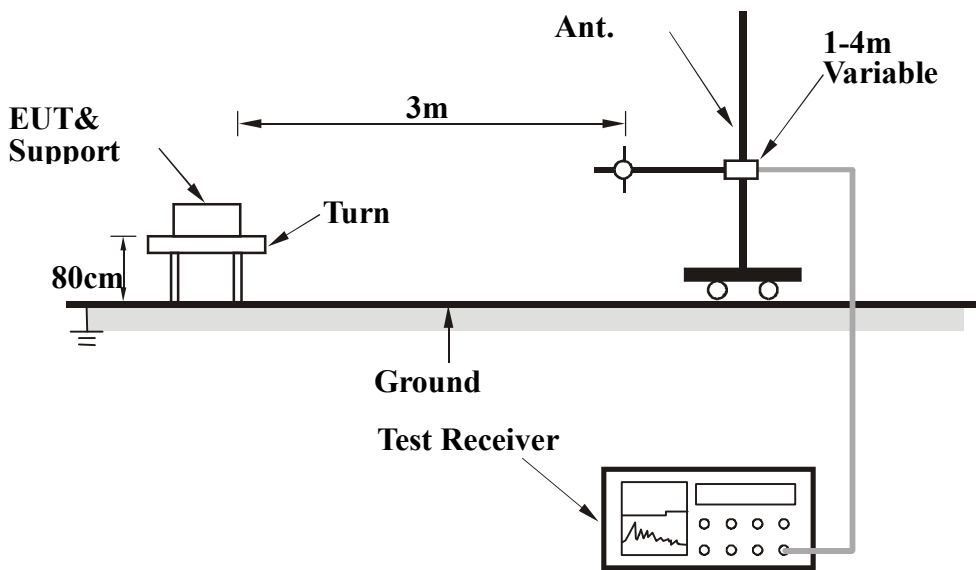

For the actual test configuration, please refer to the related item – Photographs of the Test Configuration.

#### 4.6.6 EUT OPERATING CONDITIONS

Same as item 4.1.5



A D T

#### 4.6.7 TEST RESULTS

##### CHANNEL BANDWIDTH: 5MHz

<b>MODE</b>	Low channel	<b>FREQUENCY RANGE</b>	Below 1000MHz
<b>INPUT POWER</b>	120Vac, 60Hz	<b>ENVIRONMENTAL CONDITIONS</b>	20deg°C, 60%RH 960hPa
<b>TESTED BY</b>	Frank Liu		

ANTENNA POLARITY & TEST DISTANCE: HORIZONTAL AT 3 M						
No.	Freq. (MHz)	Emission Level (dBuV/m)	Limit (dBm)	S.G level (dBm)	C.F. (dB)	Power level (dBm)
1	125	7.38	-25	-83.30	-1.21	-84.52
2	200	16.31	-25	-79.18	4.34	-74.84
3	300	30.55	-25	-65.23	3.71	-61.52
4	400	28.88	-25	-68.96	3.33	-65.63
5	450	17.63	-25	-80.63	2.81	-77.82
6	500	23.91	-25	-71.61	2.89	-68.72
7	850	2.46	-25	-92.47	2.52	-89.95

ANTENNA POLARITY & TEST DISTANCE: VERTICAL AT 3 M						
No.	Freq. (MHz)	Emission Level (dBuV/m)	Limit (dBm)	S.G level (dBm)	C.F. (dB)	Power level (dBm)
1	125	17.53	-25	-73.15	-1.21	-74.37
2	200	22	-25	-73.49	4.34	-69.15
3	300	26.39	-25	-69.39	3.71	-65.68
4	400	26.51	-25	-71.33	3.33	-68.00
5	450	21.02	-25	-77.24	2.81	-74.43
6	500	25.55	-25	-69.97	2.89	-67.08
7	850	5.27	-25	-89.66	2.52	-87.14

REMARKS: 1. Power Value(dBm)=S.G Power Value (dBm) + Correction Factor(dB)



A D T

**CHANNEL BANDWIDTH: 10MHz**

<b>MODE</b>	Low channel	<b>FREQUENCY RANGE</b>	Below 1000MHz
<b>INPUT POWER</b>	120Vac, 60Hz	<b>ENVIRONMENTAL CONDITIONS</b>	20deg°C, 60%RH 960hPa
<b>TESTED BY</b>	Frank Liu		

<b>ANTENNA POLARITY &amp; TEST DISTANCE: HORIZONTAL AT 3 M</b>						
No.	Freq. (MHz)	Emission Level (dBuV/m)	Limit (dBm)	S.G level (dBm)	C.F. (dB)	Power level (dBm)
1	125	7.62	-25	-83.06	-1.21	-84.28
2	200	16.33	-25	-79.16	4.34	-74.82
3	300	30.72	-25	-65.06	3.71	-61.35
4	400	28.61	-25	-69.23	3.33	-65.90
5	450	17.53	-25	-80.73	2.81	-77.92
6	500	23.48	-25	-72.04	2.89	-69.15
7	850	3.1	-25	-91.83	2.52	-89.31

<b>ANTENNA POLARITY &amp; TEST DISTANCE: VERTICAL AT 3 M</b>						
No.	Freq. (MHz)	Emission Level (dBuV/m)	Limit (dBm)	S.G level (dBm)	C.F. (dB)	Power level (dBm)
1	125	17.29	-25	-73.39	-1.21	-74.61
2	200	22.13	-25	-73.36	4.34	-69.02
3	300	26.45	-25	-69.33	3.71	-65.62
4	400	26.12	-25	-71.72	3.33	-68.39
5	450	21.99	-25	-76.27	2.81	-73.46
6	500	25.42	-25	-70.10	2.89	-67.21
7	850	5.31	-25	-89.62	2.52	-87.10

**REMARKS:** 1. Power Value(dBm)=S.G Power Value (dBm) + Correction Factor(dB)



A D T

## 4.7 RADIATED EMISSION MEASUREMENT (ABOVE 1GHz)

### 4.7.1 LIMITS OF RADIATED EMISSION MEASUREMENT

In the FCC 27.53(m) (4), On any frequency outside a licensee's frequency block, the power of any emission shall be attenuated below the transmitter power (P) by at least  $43 + 10 \log (P)$ dB.

### 4.7.2 TEST INSTRUMENTS

DESCRIPTION & MANUFACTURER	MODEL NO.	SERIAL NO.	CALIBRATED DATE	CALIBRATED UNTIL
ADVANTEST Spectrum Analyzer	R3271A	85060311	July 16, 2008	July 15, 2009
HP Pre_Amplifier	8449B	3008A01922	Sep. 25, 2008	Sep. 24, 2009
ROHDE & SCHWARZ Test Receiver	ESCS30	847124/029	Feb. 29, 2008	Feb. 28, 2009
SCHWARZBECK TRILOG Broadband Antenna	VULB 9168	138	April 30, 2008	April 29, 2009
Schwarzbeck Horn_Antenna	BBHA9120	D124	Dec. 09, 2008	Dec. 08, 2009
Schwarzbeck Horn_Antenna	BBHA 9170	BBHA9170153	Jan. 22, 2009	Jan. 21, 2010
RF Switches	EMH-011	08009	Oct. 07, 2008	Oct. 06, 2009
RF CABLE (Chaintek)	SF102	22054-2	Dec. 07, 2008	Dec. 06, 2009
RF Cable	8DFB	STCCAB-30M-1GHz	Oct. 07, 2008	Oct. 06, 2009
Software	ADT_Radiated_V7.6.15.9.2	NA	NA	NA
CT Antenna Tower & Turn Table	NA	NA	NA	NA
Agilent Signal generator	E8241A	US42110446	Oct. 28, 2008	Oct. 27, 2009

Note: 1. The calibration interval of the above test instruments is 12 months and the calibrations are traceable to NML/ROC and NIST/USA.

2. The horn antenna, HP preamplifier (model: 8449B) and Spectrum Analyzer (model: R3271A) are used only for the measurement of emission frequency above 1GHz if tested.

3. The test was performed in Open Site No. C.

4. The FCC Site Registration No. is 656396.

5. The VCCI Site Registration No. is R-1626.

6. The CANADA Site Registration No. is IC 7450G-3.

#### 4.7.3 TEST PROCEDURES

- a. The EUT was placed on the top of a rotating table 0.8 meters above the ground. The table was rotated 360 degrees to determine the position of the highest radiation.
- b. The EUT was set 3 meters away from the receiving antenna, which was mounted on antenna tower and its position at 0.8 m above the ground.
- c. For each suspected emission, the EUT was arranged to its worst case and the rotatable table was turned from 0 degrees to 360 degrees to find the maximum reading and recorded the value.
- d. The EUT is replaced by a horn antenna connected to a signal generator tuned to the frequency of emission.
- e. The signal generator level has to be adjusted to have the same emission nature.
- f. The radiated power can be calculated via the factor and antenna gain.
- g. Repeat step a ~ f for horizontal polarization.

**NOTE:** The resolution bandwidth of spectrum analyzer is 1MHz and the video bandwidth is 3MHz.

#### 4.7.4 DEVIATION FROM TEST STANDARD

No deviation

#### 4.7.5 TEST SETUP

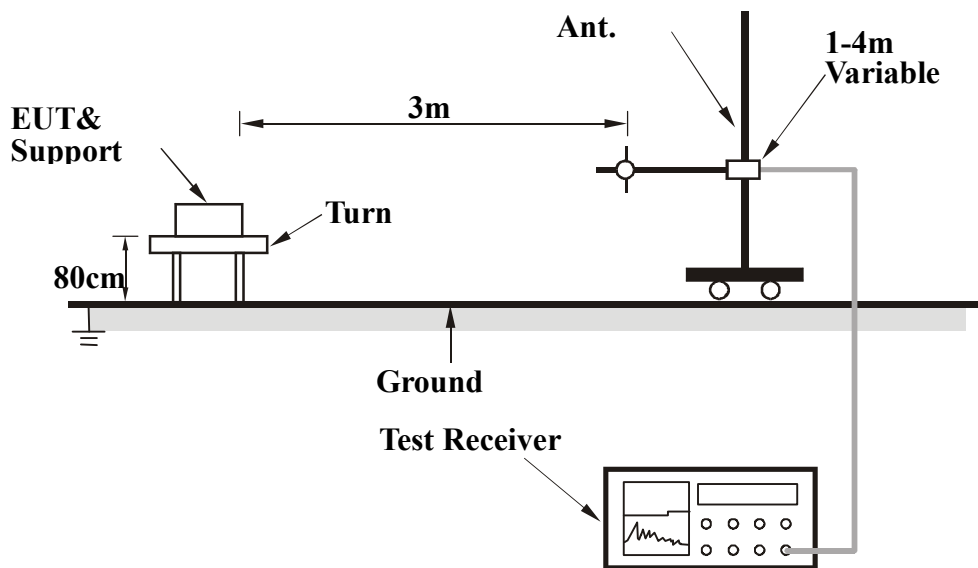

For the actual test configuration, please refer to the related item – Photographs of the Test Configuration.

#### 4.7.6 EUT OPERATING CONDITIONS

Same as item 4.1.5





A D T

#### 4.7.7 TEST RESULTS

##### CHANNEL BANDWIDTH: 5MHz

<b>MODE</b>	Low channel	<b>FREQUENCY RANGE</b>	Above 1000MHz
<b>INPUT POWER</b>	120Vac, 60Hz	<b>ENVIRONMENTAL CONDITIONS</b>	20deg°C, 60%RH 960hPa
<b>TESTED BY</b>	Rex Huang		

<b>ANTENNA POLARITY &amp; TEST DISTANCE: HORIZONTAL AT 3 M</b>						
No.	Freq. (MHz)	Emission Level (dBuV/m)	Limit (dBm)	S.G level (dBm)	C.F. (dB)	Power level (dBm)
1	5005	40.3	-25	-63.94	7.01	-56.93
2	7507.5	44.8	-25	-57.82	4.54	-53.28
3	10010	49.8	-25	-51.77	4.03	-47.74

<b>ANTENNA POLARITY &amp; TEST DISTANCE: VERTICAL AT 3 M</b>						
No.	Freq. (MHz)	Emission Level (dBuV/m)	Limit (dBm)	S.G level (dBm)	C.F. (dB)	Power level (dBm)
1	5005	50.78	-25	-53.46	7.01	-46.45
2	7507.5	51.1	-25	-51.52	4.54	-46.98
3	10010	51.5	-25	-50.07	4.03	-46.04

**REMARKS:** 1. Power Value(dBm)=S.G Power Value (dBm) + Correction Factor(dB)



A D T

<b>MODE</b>	Middle channel	<b>FREQUENCY RANGE</b>	Above 1000MHz
<b>INPUT POWER</b>	120Vac, 60Hz	<b>ENVIRONMENTAL CONDITIONS</b>	20deg°C, 60%RH 960hPa
<b>TESTED BY</b>	Rex Huang		

**ANTENNA POLARITY & TEST DISTANCE: HORIZONTAL AT 3 M**

No.	Freq. (MHz)	Emission Level (dBuV/m)	Limit (dBm)	S.G level (dBm)	C.F. (dB)	Power level (dBm)
1	5200	50	-25	-54.53	7.05	-47.48
2	7800	63.7	-25	-38.92	4.29	-34.63
3	10400	51.9	-25	-50.11	3.66	-46.44

**ANTENNA POLARITY & TEST DISTANCE: VERTICAL AT 3 M**

No.	Freq. (MHz)	Emission Level (dBuV/m)	Limit (dBm)	S.G level (dBm)	C.F. (dB)	Power level (dBm)
1	5200	58.5	-25	-46.03	7.05	-38.98
2	7800	68.2	-25	-34.42	4.29	-30.13
3	10400	54	-25	-48.01	3.66	-44.34

**REMARKS:** 1. Power Value(dBm)=S.G Power Value (dBm) + Correction Factor(dB)



A D T

<b>MODE</b>	High channel	<b>FREQUENCY RANGE</b>	Above 1000MHz
<b>INPUT POWER</b>	120Vac, 60Hz	<b>ENVIRONMENTAL CONDITIONS</b>	20deg°C, 60%RH 960hPa
<b>TESTED BY</b>	Rex Huang		

**ANTENNA POLARITY & TEST DISTANCE: HORIZONTAL AT 3 M**

No.	Freq. (MHz)	Emission Level (dBuV/m)	Limit (dBm)	S.G level (dBm)	C.F. (dB)	Power level (dBm)
1	5375	49.8	-25	-54.99	7.09	-47.90
2	8062.5	53.4	-25	-49.22	4.13	-45.09
3	10750	50.2	-25	-51.64	3.33	-48.30

**ANTENNA POLARITY & TEST DISTANCE: VERTICAL AT 3 M**

No.	Freq. (MHz)	Emission Level (dBuV/m)	Limit (dBm)	S.G level (dBm)	C.F. (dB)	Power level (dBm)
1	5375	59.6	-25	-45.19	7.09	-38.10
2	8062.5	61.3	-25	-41.32	4.13	-37.19
3	10750	55.4	-25	-46.44	3.33	-43.10

**REMARKS:** 1. Power Value(dBm)=S.G Power Value (dBm) + Correction Factor(dB)



A D T

### CHANNEL BANDWIDTH: 10MHz

<b>MODE</b>	Low channel	<b>FREQUENCY RANGE</b>	Above 1000MHz
<b>INPUT POWER</b>	120Vac, 60Hz	<b>ENVIRONMENTAL CONDITIONS</b>	20deg°C, 60%RH 960hPa
<b>TESTED BY</b>	Rex Huang		

### ANTENNA POLARITY & TEST DISTANCE: HORIZONTAL AT 3 M

No.	Freq. (MHz)	Emission Level (dBuV/m)	Limit (dBm)	S.G level (dBm)	C.F. (dB)	Power level (dBm)
1	5010	39.7	-25	-64.55	7.01	-57.53
2	7515	44.9	-25	-57.72	4.53	-53.19
3	10020	50.4	-25	-51.18	4.02	-47.16

### ANTENNA POLARITY & TEST DISTANCE: VERTICAL AT 3 M

No.	Freq. (MHz)	Emission Level (dBuV/m)	Limit (dBm)	S.G level (dBm)	C.F. (dB)	Power level (dBm)
1	5010	46.9	-25	-57.35	7.01	-50.33
2	7515	50.6	-25	-52.02	4.53	-47.49
3	10020	51.6	-25	-49.98	4.02	-45.96

**REMARKS:** 1. Power Value(dBm)=S.G Power Value (dBm) + Correction Factor(dB)



A D T

<b>MODE</b>	Middle channel	<b>FREQUENCY RANGE</b>	Above 1000MHz
<b>INPUT POWER</b>	120Vac, 60Hz	<b>ENVIRONMENTAL CONDITIONS</b>	20deg°C, 60%RH 960hPa
<b>TESTED BY</b>	Rex Huang		

**ANTENNA POLARITY & TEST DISTANCE: HORIZONTAL AT 3 M**

No.	Freq. (MHz)	Emission Level (dBuV/m)	Limit (dBm)	S.G level (dBm)	C.F. (dB)	Power level (dBm)
1	5200	45.2	-25	-59.33	7.05	-52.28
2	7800	59.7	-25	-42.92	4.29	-38.63
3	10400	52.1	-25	-49.91	3.66	-46.24

**ANTENNA POLARITY & TEST DISTANCE: VERTICAL AT 3 M**

No.	Freq. (MHz)	Emission Level (dBuV/m)	Limit (dBm)	S.G level (dBm)	C.F. (dB)	Power level (dBm)
1	5200	52.7	-25	-51.83	7.05	-44.78
2	7800	64.5	-25	-38.12	4.29	-33.83
3	10400	53.9	-25	-48.11	3.66	-44.44

**REMARKS:** 1. Power Value(dBm)=S.G Power Value (dBm) + Correction Factor(dB)



A D T

<b>MODE</b>	High channel	<b>FREQUENCY RANGE</b>	Above 1000MHz
<b>INPUT POWER</b>	120Vac, 60Hz	<b>ENVIRONMENTAL CONDITIONS</b>	20deg°C, 60%RH 960hPa
<b>TESTED BY</b>	Rex Huang		

**ANTENNA POLARITY & TEST DISTANCE: HORIZONTAL AT 3 M**

No.	Freq. (MHz)	Emission Level (dBuV/m)	Limit (dBm)	S.G level (dBm)	C.F. (dB)	Power level (dBm)
1	5370	50.5	-25	-54.29	7.09	-47.19
2	8055	57.8	-25	-44.82	4.13	-40.69
3	10740	51.1	-25	-51.29	3.35	-47.94

**ANTENNA POLARITY & TEST DISTANCE: VERTICAL AT 3 M**

No.	Freq. (MHz)	Emission Level (dBuV/m)	Limit (dBm)	S.G level (dBm)	C.F. (dB)	Power level (dBm)
1	5370	60	-25	-44.79	7.09	-37.69
2	8055	65.6	-25	-37.02	4.13	-32.89
3	10740	55.9	-25	-46.49	3.35	-43.14

**REMARKS:** 1. Power Value(dBm)=S.G Power Value (dBm) + Correction Factor(dB)



A D T

## 5 PHOTOGRAPHS OF THE TEST CONFIGURATION

Please refer to the attached file (Test Setup Photo).





A D T

## 6 INFORMATION ON THE TESTING LABORATORIES

We, Bureau Veritas Consumer Products Services (H.K.) Ltd., Taoyuan Branch, were founded in 1988 to provide our best service in EMC, Radio, Telecom and Safety consultation. Our laboratories are accredited and approved by the following approval agencies according to ISO/IEC 17025.

<b>USA</b>	FCC, NVLAP
<b>Germany</b>	TUV Rheinland
<b>Japan</b>	VCCI
<b>Norway</b>	NEMKO
<b>Canada</b>	INDUSTRY CANADA , CSA
<b>R.O.C.</b>	TAF, BSMI, NCC
<b>Netherlands</b>	Telefication
<b>Singapore</b>	GOST-ASIA(MOU)
<b>Russia</b>	CERTIS(MOU)

Copies of accreditation certificates of our laboratories obtained from approval agencies can be downloaded from our web site:

[www.adt.com.tw/index.5/phtml](http://www.adt.com.tw/index.5/phtml). If you have any comments, please feel free to contact us at the following:

**Linko EMC/RF Lab:**

Tel: 886-2-26052180

Fax: 886-2-26051924

**Hsin Chu EMC/RF Lab:**

Tel: 886-3-5935343

Fax: 886-3-5935342

**Hwa Ya EMC/RF/Safety/Telecom Lab: Web Site: [www.adt.com.tw](http://www.adt.com.tw)**

Tel: 886-3-3183232

Fax: 886-3-3185050

The address and road map of all our labs can be found in our web site also.





A D T

## 7 APPENDIX- A DL/UL RATION FOR TEST

### For reference (5MHz)

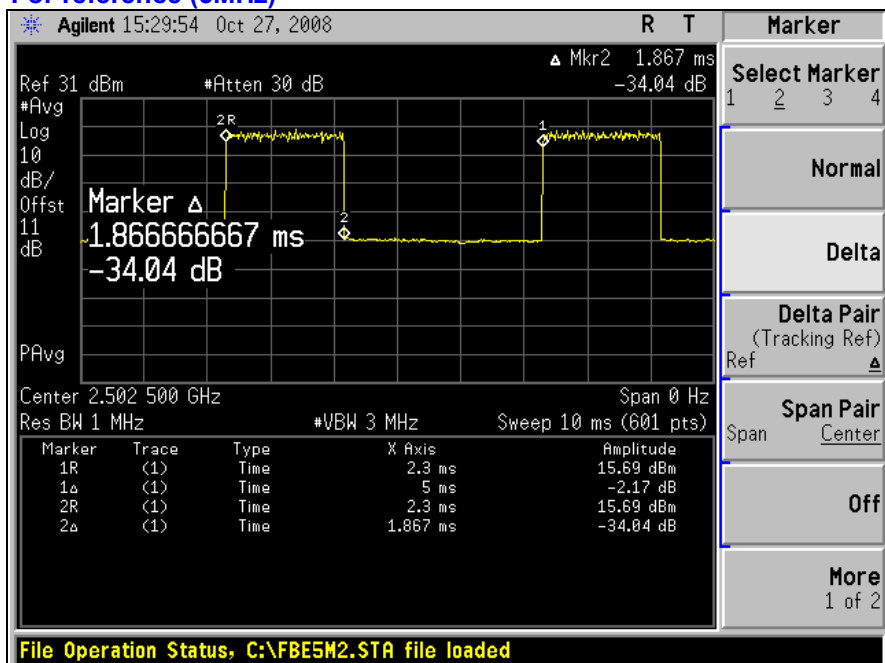

The ration is approximate 37.3%.

### For reference(10MHz)

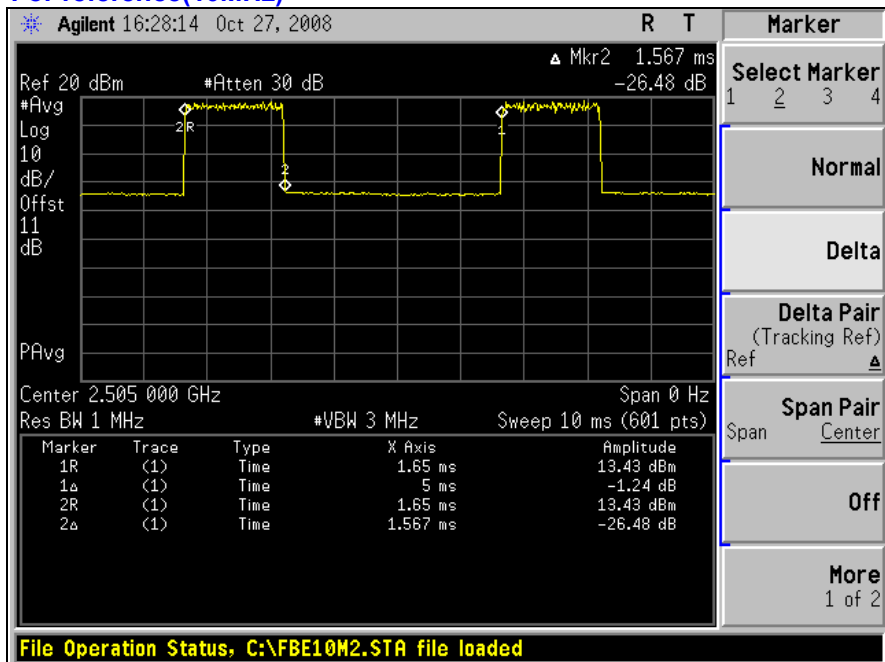

The ration is approximate 31.3%.

--- END ---