

# APPROVAL SHEET

MULTILAYER CERAMIC ANTENNA

**RFANT Series**

2.4 GHz ISM Band Working Frequency

**P/N: RFANT5220110A0T**

Customer : Universal Scientific Industrial Co., Ltd

Approval No : \_\_\_\_\_

Issue Date : June 18, 2003

Customer Approval :

WALSIN Technology Corp.

Authorized By : 

**FEATURES**

- Surface Mounted Devices with a small dimension of 5.2 x 2.0 x 1.1 mm<sup>3</sup> meet future miniaturization trend.
- Embedded and LTCC (Low Temperature Co-fired Ceramic) technology is able to future integrate with system design as well as beautifying the housing of final product.
- High Stability in Temperature / Humidity Change

**APPLICATIONS**

- Bluetooth
- Wireless LAN
- HornRF
- ISM band 2.4GHz wireless applications

**DESCRIPTION**

Walsin Technology Corporation develops a new ceramic embedded antenna specified for 2.4 GHz ISM Band application, as shown in below "CONSTRUCTION". Both of Wireless LAN IEEE 802.11b and Bluetooth™ typically located on this unlicensed frequency band which range covers from 2.4GHz to 2.4835GHz. To fulfil the friendly usage for antenna, this antenna has been designed to a typical 150MHz bandwidth through Walsin's advanced LTCC (Low Temperature Co-fired Ceramic) technology and superior product design via 3D EM Simulation Skill.

This antenna has a rectangular ceramic body with a tiny dimension of 5.2x 2.0 x 1.1 mm<sup>3</sup> meet the future SMT automation and miniaturization requirements on modern portable devices.

**CONSTRUCTION**

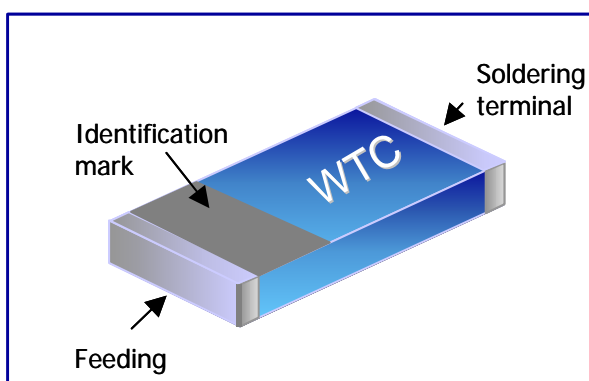

Fig 1. Outline of 2.4GHz Antenna – RFANT5220110A0T

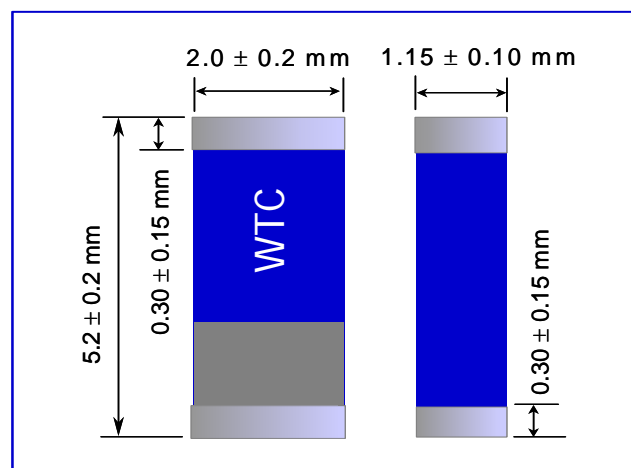
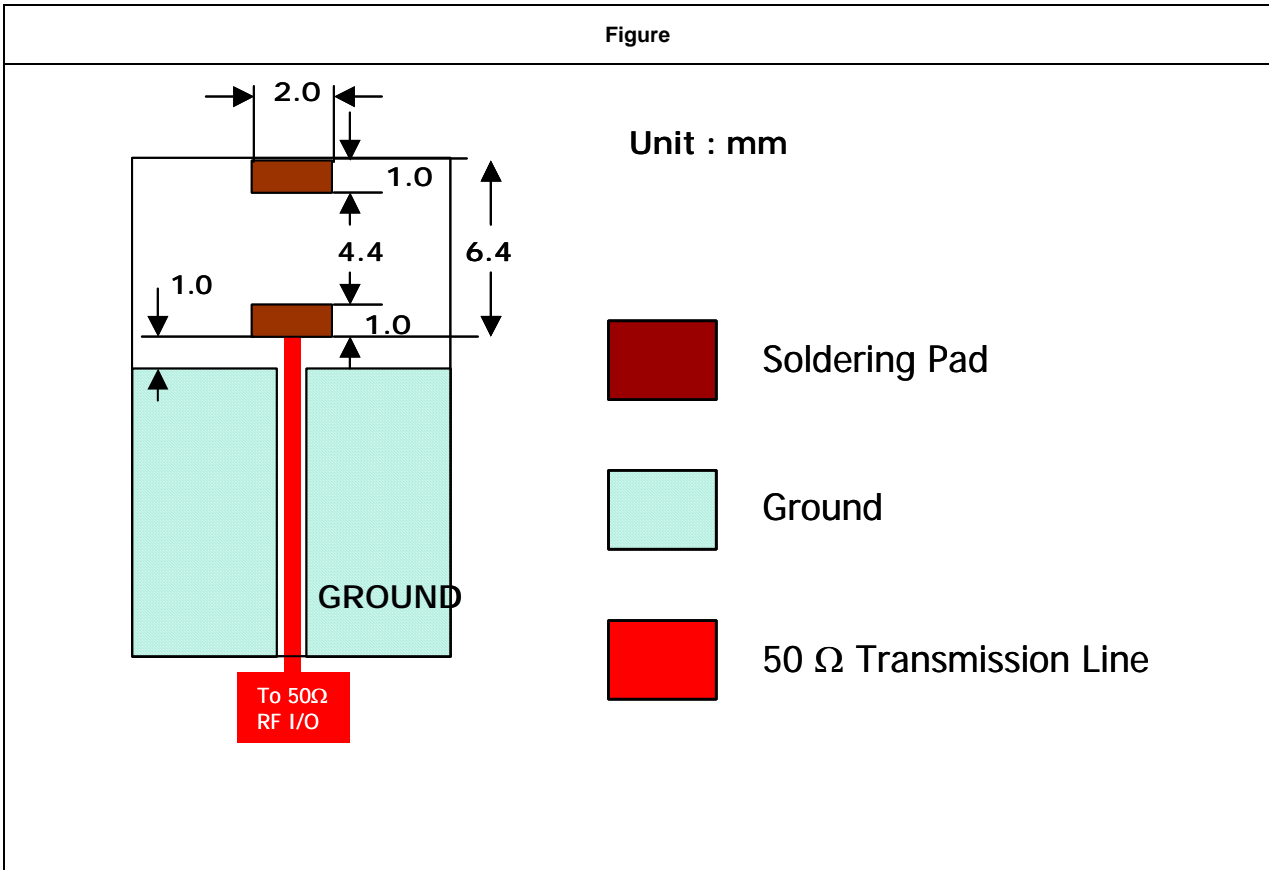

Fig 2. Dimension

**SOLDER LAND PATTERN DESIGN**



**ELECTRICAL CHARACTERISTICS**

Item	Specification
Working Frequency Range	2.4 GHz    2.5GHz
Gain	2 dBi (Typical)
VSWR	2 max.
Polarization	Linear
Azimuth Beamwidth	Omni-directional
Impedance	50Ω
Rated Power (max.)	3 Watts
Maximum Input Power	5 Watts for 5 minutes

**Remark: The specification is defined based on the test board dimension as in below**

Antenna on Test Board ( FR4 Thickness 0.8mm)

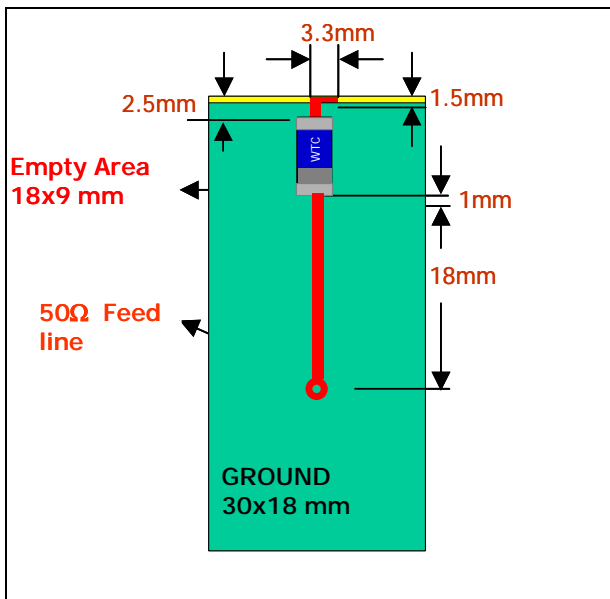

Antenna S11 on Test Board

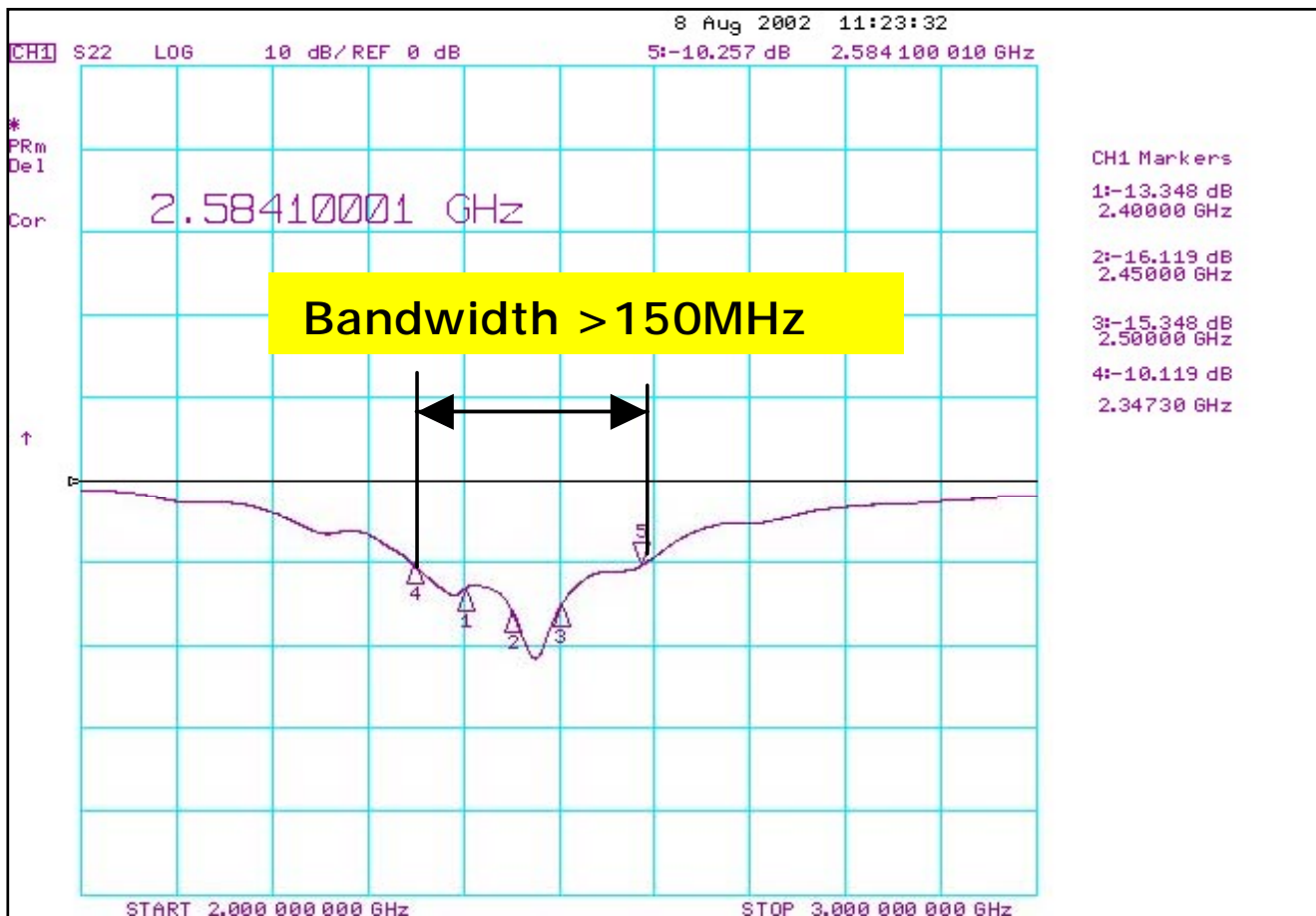

**RADIATION PATTERN**

Radiation Pattern and Gain were dependent on measurement board design. The specification of RFANT5220110A0T antenna was measured based on the PCB size and installation position as shown in the below figure Test Board

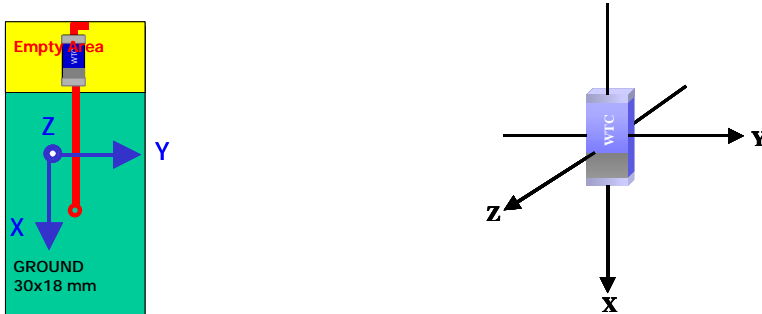

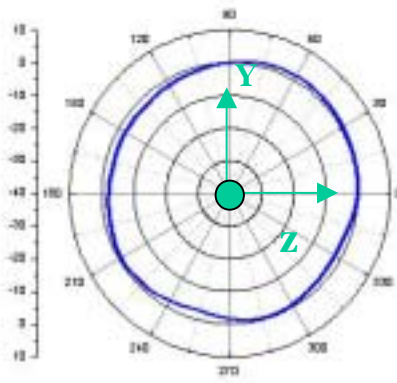
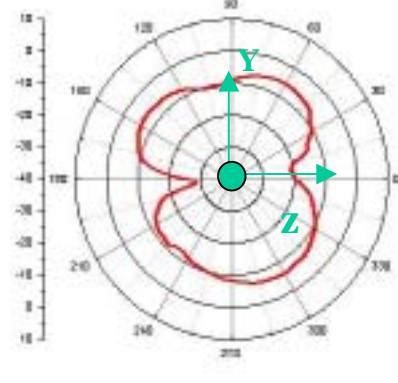
	Vertical	Horizontal
Y - Z Plane		
Average Gain = -3.22 dBi	Peak Gain = 1.69 dBi Average Gain = -0.82 dBi	Peak Gain = -5.42 dBi Average Gain = -8.98 dBi

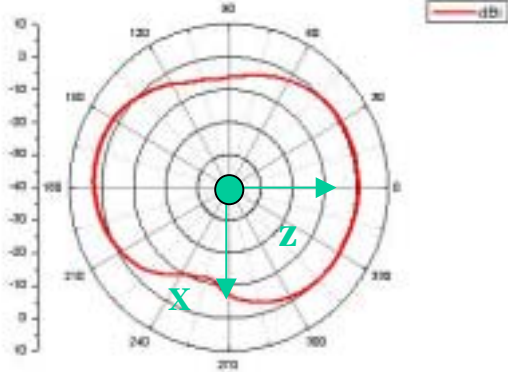
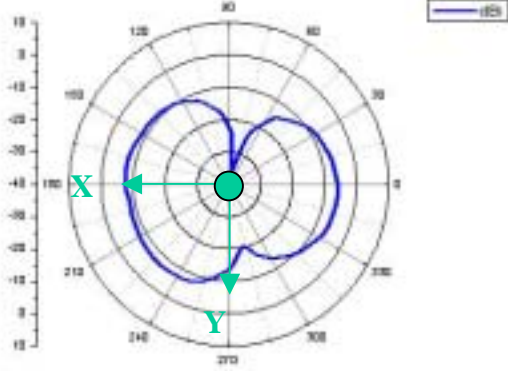
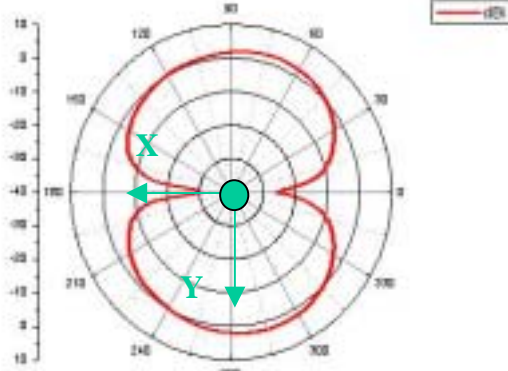
<p><b>X - Z Plane</b></p> <p>Average Gain= -3.24 dBi</p>	 <p>Peak Gain= -5.97 dBi Average Gain= -8.61dBi</p>	 <p>Peak Gain= 2.66 dBi Average Gain= -0.91 dBi</p>
<p><b>X - Y Plane</b></p> <p>Average Gain= -3.12 dBi</p>	 <p>Peak Gain= -5.97 dBi Average Gain= -9.24dBi</p>	 <p>Peak Gain= 2.59 dBi Average Gain= -0.68 dBi</p>

**APPLICATION INFORMATION**

**(1). RFANT5220110A0T on Card-Bus Layout Proposal – (56mm x 43mm)**

Project Name: Hermes2 CF Card (TITAN)

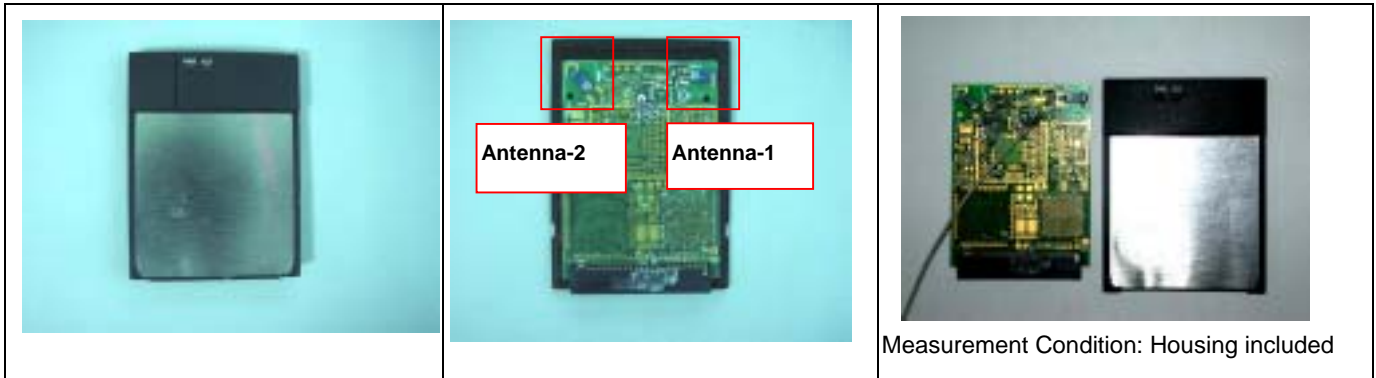

**(2). VSWR and S11 Measurement Results:**

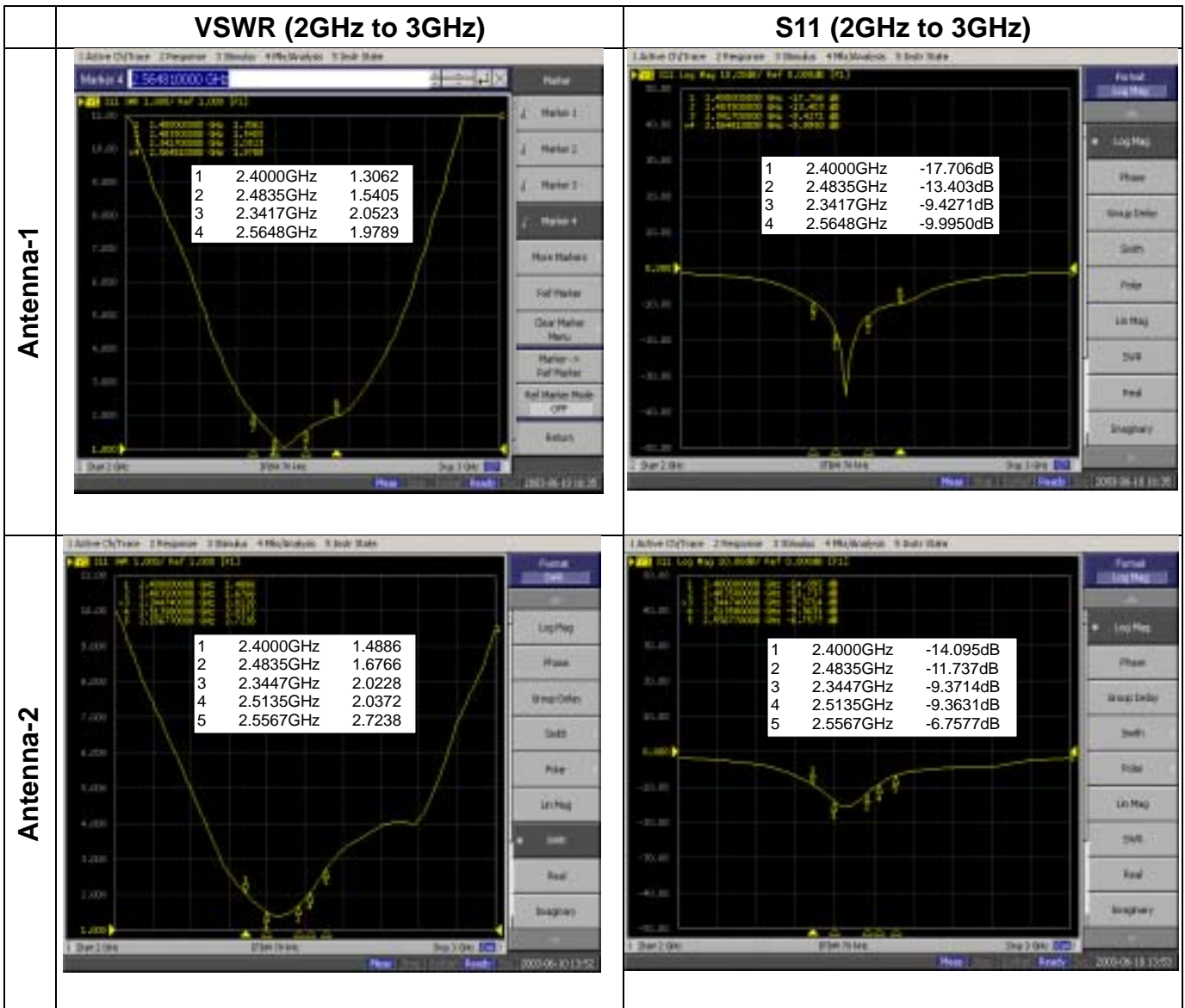

Radiation Pattern at 2.45GHz:

(1). Antenna-1:

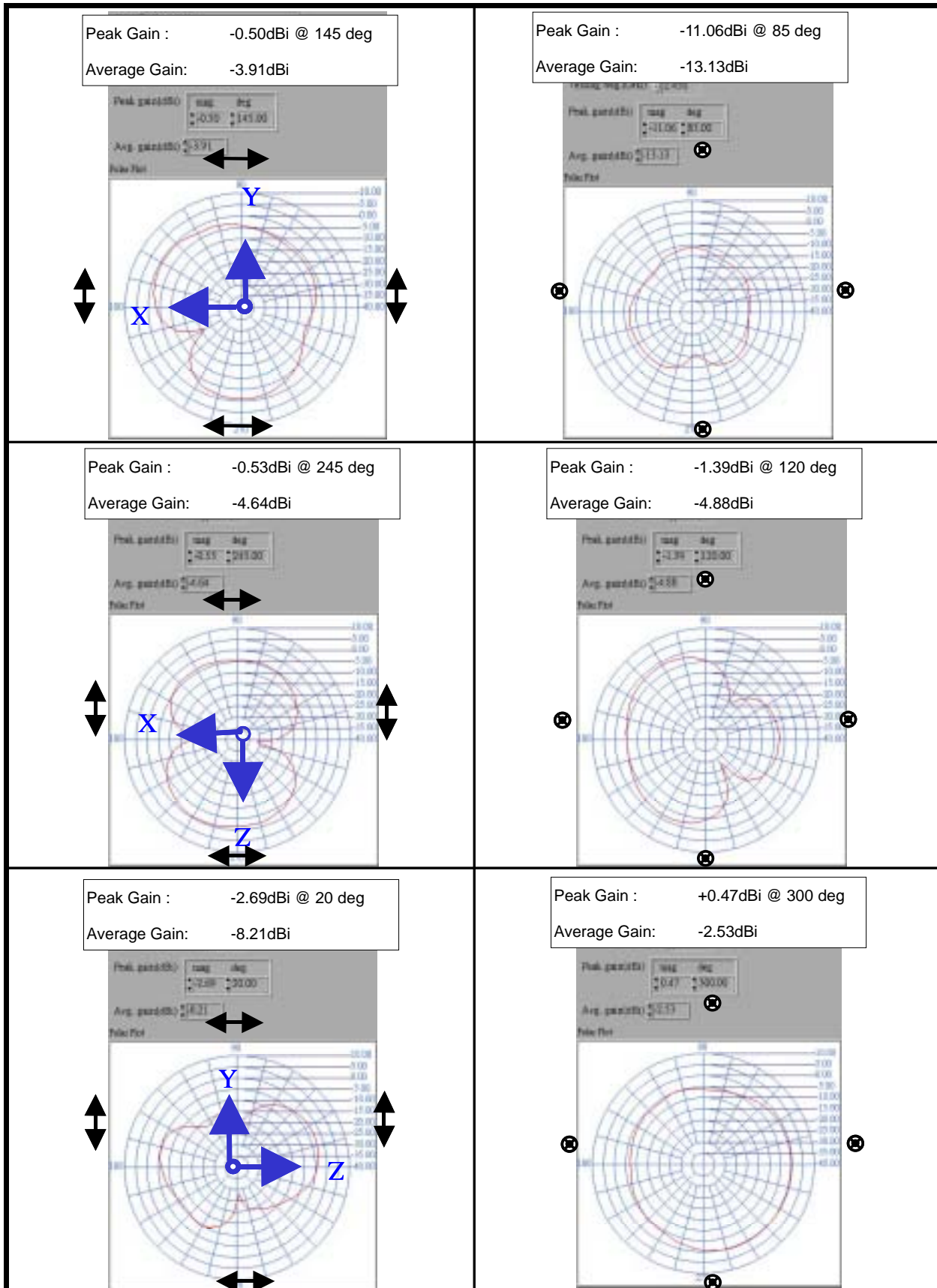



(2). Antenna-2:

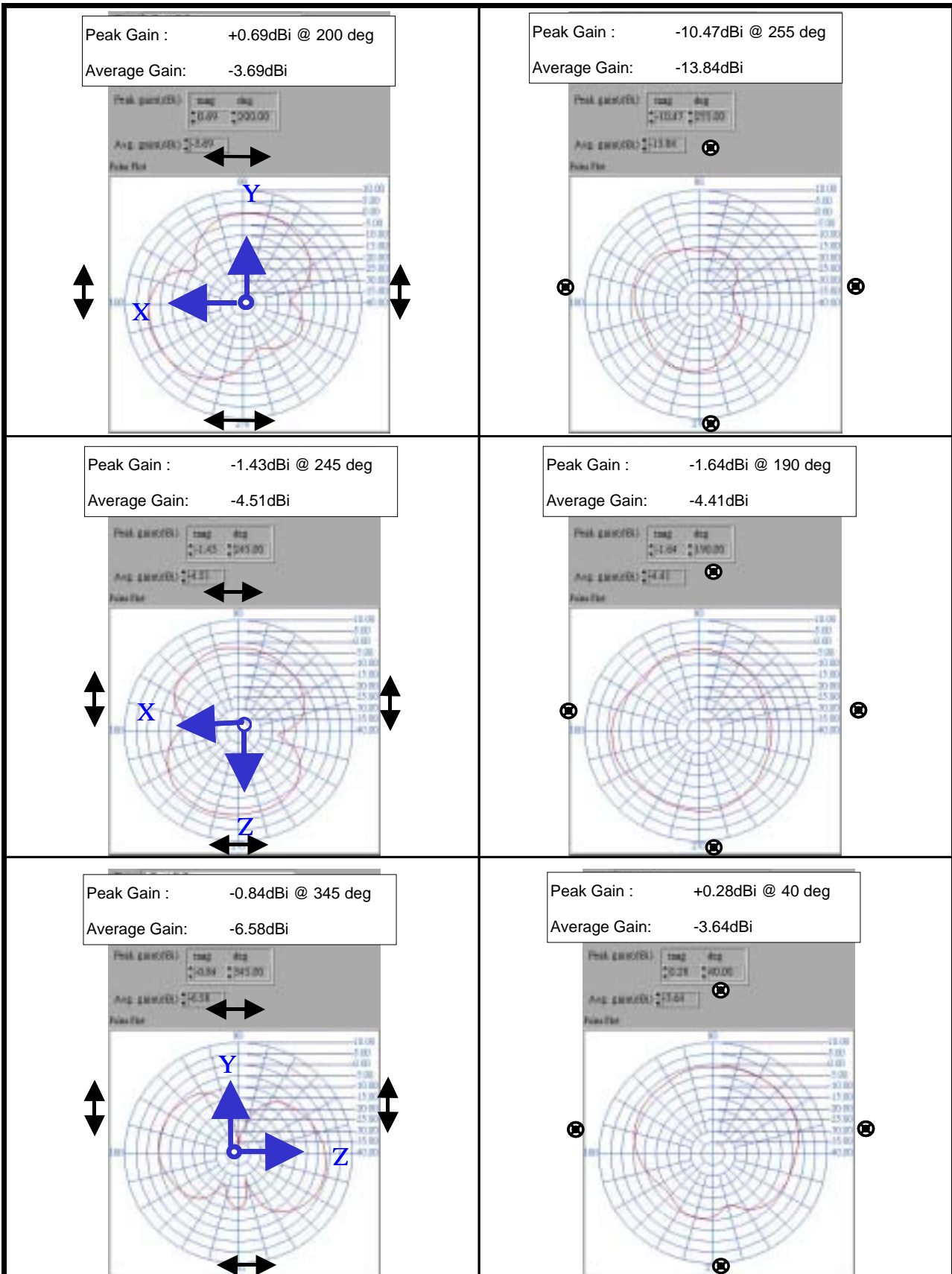

**(3). General information**

The performance of embedded ceramic antenna could be sensitive influenced by customer's grounding area, PC board size, thickness, material, mechanical design and the material of housing for end product. The performance is guaranteed based on the installation as shown in test board, **to reserve a "II" network is suggested for final matching** if the housing was included.

Walsin engineers have significant expertise on embedded antenna designs and applications. We can work closely with you to ensure the requirements are met, and optimise the Walsin antenna performance when installing on your application.

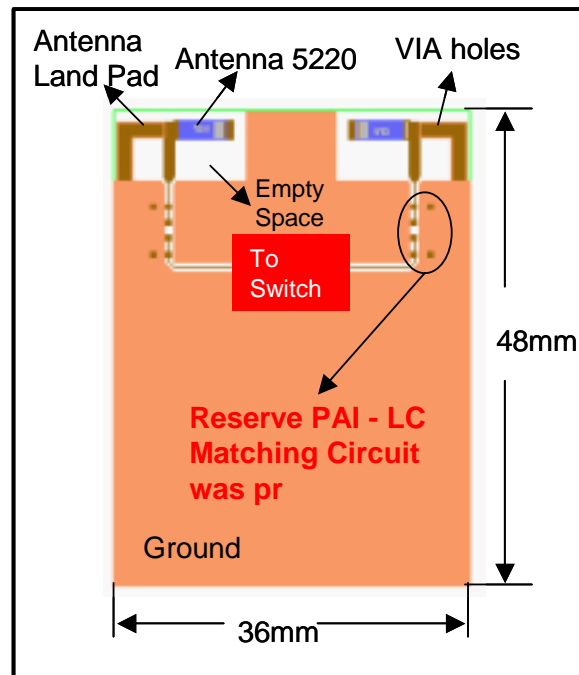

## RELIABILITY TEST

### ■ Mechanical performance

Test item	Test condition / Test method	Specification
Solderability	Solder temp. : $235 \pm 5^{\circ}\text{C}$ Immersion time: $2 \pm 1$ sec Solder: SN63	95% min. coverage of all metabolised area
Resistance to soldering heat	Solder: Sn63 Preheating temperature: $150 \pm 10^{\circ}\text{C}$ Solder Temperature: $260 \pm 5^{\circ}\text{C}$ Immersion time: $10 \pm 1$ sec Measurement to be made after keeping at room temp. for $24 \pm 2$ hrs.	No mechanical damage. Ceramic surface shall not be exposed in the middle of the termination or on the terminated product edge by leaching.
Drop test	Height : 75 cm Times : 3 times.	No mechanical damage. Samples shall satisfy electrical specification after test..

### Environmental characteristics

Test item	Test condition / Test method	Specification
Humidity Resistance	Humidity: 90% to 95% R.H. Tempertaure: $40 \pm 2^{\circ}\text{C}$ Time: $500 \pm 24$ hours. Measurement: After placing for 24 hours Minimum.	No mechanical damage. Samples shall satisfy electrical specification after test.
Temperature cycle	1. $30 \pm 3$ minutes at $-40^{\circ}\text{C} \pm 3^{\circ}\text{C}$ , 2. 10~15 minutes at room temperature, 3. $30 \pm 3$ minutes at $+85^{\circ}\text{C} \pm 3^{\circ}\text{C}$ , 4. 10~15 minutes at room temperature, Total 100 continuous cycles Measurement after placing for $48 \pm 2$ hrs min.	No mechanical damage. Samples shall satisfy electrical specification after test.
High temperature	Temperature: $85^{\circ}\text{C} \pm 2^{\circ}\text{C}$ Test duration: 24 hours Measurement must be taken after subjection to the above conditions, followed by exposure in room environment for 1 to 2 hours.	No mechanical damage. Samples shall satisfy electrical specification after test.
Low temperature	Temperature: $-40^{\circ}\text{C} \pm 3^{\circ}\text{C}$ Test duration: 24 hours Measurement must be taken after subjection to the above conditions, followed by exposure in room environment for 1 to 2 hours.	No mechanical damage. Samples shall satisfy electrical specification after test.

### ORDERING CODE

<b>RF</b>	<b>ANT</b>	<b>522011</b>	<b>0</b>	<b>A</b>	<b>0</b>	<b>T</b>
Walsin RF device	<b>Product code</b> ANT : Antenna	<b>Dimension code</b> Per 2 digits of Length, Width, Thickness	<b>Unit of dimension</b> 0 : 0.1 mm 1 : 1.0 mm	<b>Application</b> A : 2.4GHZ ISM Band	<b>Specification</b> Code from 0 ~ 9 dependent on different electrical specification	<b>Packing</b> T : 7" Reeled G : 10" Reeled B : Bulk X : SFC product

### PACKAGING

Plastic Tape specifications (unit :mm)

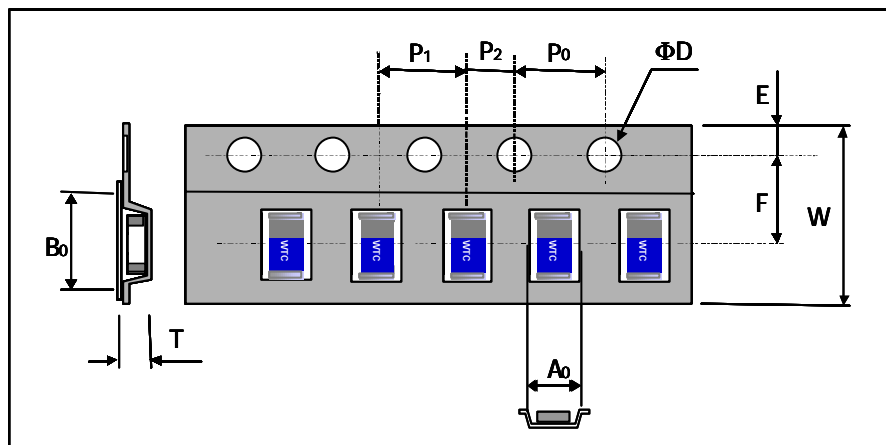

Index	Ao	Bo	ΦD	T	W
Dimension (mm)	2.40 ± 0.10	5.50 ± 0.10	1.55 ± 0.05	1.20 ± 0.10	12.0 ± 0.10
Index	E	F	Po	P1	P2
Dimension (mm)	1.75 ± 0.10	5.50 ± 0.10	4.00 ± 0.10	4.00 ± 0.10	2.00 ± 0.10

### Reel dimensions

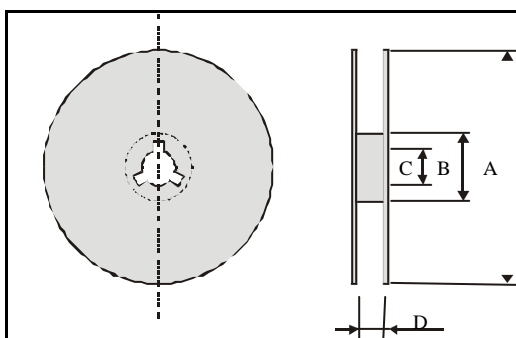

Index	A	B	C	D
Dimension (mm)	Φ178	Φ60.0	Φ13.5	12.4±0.1

Typing Quantity: 2000 pieces per 7" reel

## CAUTION OF HANDLING

### Limitation of Applications

Please contact us before using our products for the applications listed below which require especially high reliability for the prevention of defects, which might directly cause damage to the third party's life, body or property.

- (1) Aircraft equipment
- (2) Aerospace equipment
- (3) Undersea equipment
- (4) Medical equipment
- (5) Disaster prevention / crime prevention equipment
- (6) Traffic signal equipment
- (7) Transportation equipment (vehicles, trains, ships, etc.)
- (8) Applications of similar complexity and /or reliability requirements to the applications listed in the above.

### Storage condition

- (1) Products should be used in 6 months from the day of WALSIN outgoing inspection, which can be confirmed.
- (2) Storage environment condition.
  - Products should be storage in the warehouse on the following conditions.
  - Temperature : -10 to +40°C
  - Humidity : 30 to 70% relative humidity
  - Don't keep products in corrosive gases such as sulfur. Chlorine gas or acid or it may cause oxidization of electrode, resulting in poor solderability.
  - Products should be storage on the palette for the prevention of the influence from humidity, dust and so on.
  - Products should be storage in the warehouse without heat shock, vibration, direct sunlight and so on.

Products should be storage under the airtight packaged condition.