



FCC RF Test Report

APPLICANT : Universal Scientific Industrial Co., Ltd.
EQUIPMENT : UNA_900
BRAND NAME : Universal Global Scientific Industrial Co., Ltd.
MODEL NAME /
MARKETING NAME : UNA_900
FCC ID : IXM-UNA900
STANDARD : FCC 47 CFR Part 2, 22(H), 24(E)
CLASSIFICATION : PCS Licensed Transmitter (PCB)
Tx/Rx FREQUENCY RANGE : GSM850 : 824.2 ~ 848.8 MHz /
869.2 ~ 893.8 MHz
GSM1900 : 1850.2 ~ 1909.8 MHz /
1930.2 ~ 1989.8 MHz
MAX. ERP/EIRP POWER : GSM850 (GSM) : 1.57 W
GSM850 (EDGE 8) : 0.38 W
GSM1900 (GSM) : 1.14 W
GSM1900 (EDGE 8) : 0.43 W

The product was received on Mar. 17, 2012 and completely tested on Mar. 24, 2012. We, SPORTON INTERNATIONAL INC., would like to declare that the tested sample has been evaluated in accordance with the procedures given in ANSI / TIA / EIA-603-C-2004 and shown compliance with the applicable technical standards.

The test results in this report apply exclusively to the tested model / sample. Without written approval of SPORTON INTERNATIONAL INC., the test report shall not be reproduced except in full.

Reviewed by:

Jones Tsai / Manager



SPORTON INTERNATIONAL INC.

No. 52, Hwa Ya 1st Rd., Hwa Ya Technology Park, Kwei-Shan Hsiang, Tao Yuan Hsien, Taiwan, R.O.C.

SPORTON INTERNATIONAL INC.

TEL : 886-3-327-3456

FAX : 886-3-328-4978

FCC ID : IXM-UNA900

Page Number : 1 of 63

Report Issued Date : Apr. 17, 2012

Report Version : Rev. 03



TABLE OF CONTENTS

REVISION HISTORY..... 3

SUMMARY OF TEST RESULT 4

1 GENERAL DESCRIPTION 5

 1.1 Applicant..... 5

 1.2 Manufacturer 5

 1.3 Feature of Equipment Under Test..... 5

 1.4 Emission Designator and Maximum ERP/EIRP Power 6

 1.5 Testing Site..... 6

 1.6 Applied Standards 6

 1.7 Ancillary Equipment List 7

2 TEST CONFIGURATION OF EQUIPMENT UNDER TEST 8

 2.1 Test Mode..... 8

 2.2 Connection Diagram of Test System 9

3 TEST RESULT 10

 3.1 Conducted Output Power Measurement 10

 3.2 Effective Radiated Power and Effective Isotropic Radiated Power Measurement 12

 3.3 Occupied Bandwidth Measurement 14

 3.4 Band Edge Measurement..... 27

 3.5 Conducted Emission Measurement 36

 3.6 Field Strength of Spurious Radiation Measurement 47

 3.7 Frequency Stability Measurement..... 57

4 LIST OF MEASURING EQUIPMENT 61

5 UNCERTAINTY OF EVALUATION 63

APPENDIX A. PHOTOGRAPHS OF EUT

APPENDIX B. SETUP PHOTOGRAPHS



REVISION HISTORY

REPORT NO.	VERSION	DESCRIPTION	ISSUED DATE
FG231721	Rev. 01	Initial issue of report	Apr. 03, 2012
FG231721	Rev. 02	Update report by revising company name and address of applicant and manufacturer.	Apr. 13, 2012
FG231721	Rev. 03	Update report by revising Applied Standards and adding evaluation board in Ancillary Equipment List.	Apr. 17, 2012



SUMMARY OF TEST RESULT

Report Section	FCC Rule	IC Rule	Description	Limit	Result	Remark
3.1	§2.1046	N/A	Conducted Output Power	N/A	PASS	-
3.2	§22.913(a)(2)	RSS-132(4.4) SRSP-503(5.1.3)	Effective Radiated Power	< 7 Watts	PASS	-
3.2	§24.232(c)	RSS-133 (6.4) SRSP-510(5.1.2)	Equivalent Isotropic Radiated Power	< 2 Watts	PASS	-
3.3	§2.1049 §22.917(a) §24.238(a)	N/A	Occupied Bandwidth	N/A	PASS	-
3.4	§2.1051 §22.917(a) §24.238(a)	RSS-132 (4.5.1) RSS-133 (6.5.1)	Band Edge Measurement	< 43+10log ₁₀ (P[Watts])	PASS	-
3.5	§2.1051 §22.917(a) §24.238(a)	RSS-132 (4.5.1) RSS-133 (6.5.1)	Conducted Emission	< 43+10log ₁₀ (P[Watts])	PASS	-
3.6	§2.1053 §22.917(a) §24.238(a)	RSS-132 (4.5.1) RSS-133 (6.5.1)	Field Strength of Spurious Radiation	< 43+10log ₁₀ (P[Watts])	PASS	Under limit 32.08 dB at 7520.000 MHz
3.7	§2.1055 §22.355 §24.235	RSS-132(4.3) RSS-133(6.3)	Frequency Stability for Temperature & Voltage	< 2.5 ppm	PASS	-

1 General Description

1.1 Applicant

Universal Scientific Industrial Co., Ltd.

141, Lane 351, Taiping Road, Sec. 1, Tsao Tuen, Nan-Tou, Taiwan

1.2 Manufacturer

Universal Scientific Industrial Co., Ltd.

141, Lane 351, Taiping Road, Sec. 1, Tsao Tuen, Nan-Tou, Taiwan

1.3 Feature of Equipment Under Test

Product Feature & Specification	
Equipment	UNA_900
Brand Name	Universal Global Scientific Industrial Co., Ltd.
Model Name / Marketing Name	UNA_900
FCC ID	IXM-UNA900
Tx Frequency	GSM850 : 824 MHz ~ 849 MHz GSM1900 : 1850 MHz ~ 1910 MHz
Rx Frequency	GSM850 : 869 MHz ~ 894 MHz GSM1900 : 1930 MHz ~ 1990 MHz
Maximum Output Power to Antenna	GSM850 : 32.11 dBm GSM1900 : 28.55 dBm
HW Version	V2.1
SW Version	MAUI.11A.W11.12.MP.V67.F1
Type of Modulation	GSM: GMSK GPRS: GMSK EDGE: GMSK / 8PSK
EUT Stage	Identical Prototype

Remark: The above EUT's information was declared by manufacturer. Please refer to the specifications or user's manual for more detailed description.

1.4 Emission Designator and Maximum ERP/EIRP Power

FCC Rule	System	Type of Modulation	Emission Designator	Maximum ERP/EIRP
Part 22	GSM850 GSM	GMSK	246KGXW	1.57 W
Part 22	GSM850 EDGE 8	GMSK / 8PSK	242KG7W	0.38 W
Part 24	GSM1900 GSM	GMSK	248KGXW	1.14 W
Part 24	GSM1900 EDGE 8	GMSK / 8PSK	250KG7W	0.43 W

1.5 Testing Site

Test Site	SPORTON INTERNATIONAL INC.		
Test Site Location	No. 52, Hwa Ya 1 st Rd., Hwa Ya Technology Park, Kwei-Shan Hsiang, Tao Yuan Hsien, Taiwan, R.O.C. TEL: +886-3-327-3456 FAX: +886-3-328-4978		
Test Site No.	Sporton Site No.		FCC/IC Registration No.
	TH02-HY	03CH05-HY	722060/4086B-1

1.6 Applied Standards

According to the specifications of the manufacturer, the EUT must comply with the requirements of the following standards:

- FCC 47 CFR Part 2, 22(H), 24(E)
- ANSI / TIA / EIA-603-C-2004
- IC RSS-132 Issue 2
- IC RSS-133 Issue 5

Remark:

1. All test items were verified and recorded according to the standards and without any deviation during the test.
2. This EUT has also been tested and complied with the requirements of FCC Part 15, Subpart B, recorded in a separate test report.



1.7 Ancillary Equipment List

Item	Equipment	Trade Name	Model No.	FCC ID	Data Cable	Power Cord
1.	System Simulator	R&S	CMU200	N/A	N/A	Unshielded, 1.8 m
2.	Notebook	DELL	Vostro 1510	FCC DoC	N/A	AC I/P: Unshielded, 1.2 m DC O/P: Shielded, 1.8 m
3.	Evaluation Board	N/A	N/A	N/A	N/A	N/A

2 Test Configuration of Equipment Under Test

2.1 Test Mode

During all testing, EUT is in link mode with base station emulator at maximum power level. The spurious emission measurements were carried out in semi-anechoic chamber with 3-meter test range.

Frequency range investigated for radiated emission is as follows:

1. 30 MHz to 9000 MHz for GSM850
2. 30 MHz to 19000 MHz for GSM1900.

Test Modes		
Band	Radiated TCs	Conducted TCs
GSM 850	<ul style="list-style-type: none"> ■ GSM Link ■ EDGE 8 Link 	<ul style="list-style-type: none"> ■ GSM Link ■ EDGE 8 Link
GSM 1900	<ul style="list-style-type: none"> ■ GSM Link ■ EDGE 8 Link 	<ul style="list-style-type: none"> ■ GSM Link ■ EDGE 8 Link

Note: The maximum power levels are GSM mode for GMSK link and EDGE multi-slot class 8 mode for 8PSK link, only these modes were used for all tests.

The conducted power tables are as follows:

Conducted Power (*Unit: dBm)						
Band	GSM850			GSM1900		
Channel	128	189	251	512	661	810
Frequency	824.2	836.4	848.8	1850.2	1880.0	1909.8
GSM	32.11	32.07	31.96	28.55	28.51	28.46
GPRS 8	32.10	32.06	31.95	28.54	28.51	28.46
GPRS 10	31.39	31.28	31.18	27.91	27.88	27.84
GPRS 12	28.64	28.52	28.42	25.28	25.24	25.22
EGPRS 8	25.96	25.92	25.87	24.30	24.34	24.14
EGPRS 10	24.92	24.87	24.82	23.28	23.34	23.10
EGPRS 12	21.86	21.86	21.81	20.20	20.22	19.99

2.2 Connection Diagram of Test System

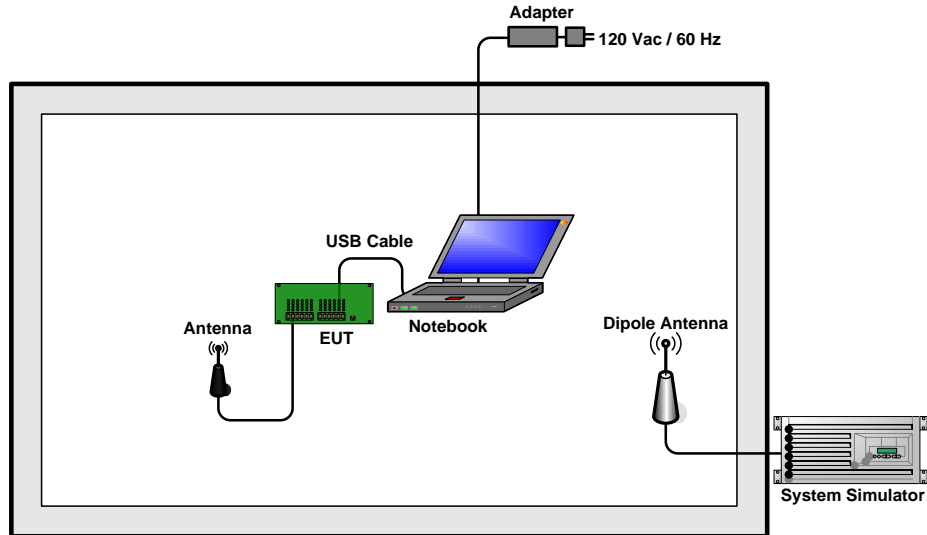

3 Test Result

3.1 Conducted Output Power Measurement

3.1.1 Description of the Conducted Output Power Measurement

A base station simulator was used to establish communication with the EUT. Its parameters were set to transmit the maximum power on the EUT. The measured power in the radio frequency on the transmitter output terminals shall be reported.

3.1.2 Measuring Instruments

See list of measuring instruments of this test report.

3.1.3 Test Procedures

1. The transmitter output port was connected to base station.
2. Set EUT at maximum power through base station.
3. Select lowest, middle, and highest channels for each band and different modulation.

3.1.4 Test Setup

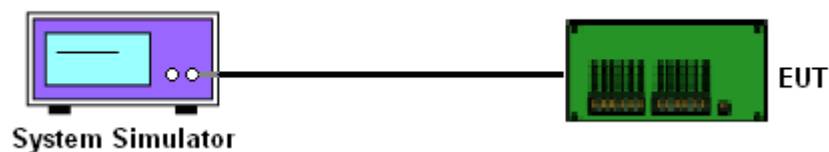



3.1.5 Test Result of Conducted Output Power

Cellular Band						
Modes	GSM850 (GSM)			GSM850 (EDGE 8)		
Channel	128 (Low)	189 (Mid)	251 (High)	128 (Low)	189 (Mid)	251 (High)
Frequency (MHz)	824.2	836.4	848.8	824.2	836.4	848.8
Conducted Power (dBm)	32.11	32.07	31.96	25.96	25.92	25.87
Conducted Power (Watts)	1.63	1.61	1.57	0.39	0.39	0.39

PCS Band						
Modes	GSM1900 (GSM)			GSM1900 (EDGE 8)		
Channel	512 (Low)	661 (Mid)	810 (High)	512 (Low)	661 (Mid)	810 (High)
Frequency (MHz)	1850.2	1880	1909.8	1850.2	1880	1909.8
Conducted Power (dBm)	28.55	28.51	28.46	24.30	24.34	24.14
Conducted Power (Watts)	0.72	0.71	0.70	0.27	0.27	0.26

3.2 Effective Radiated Power and Effective Isotropic Radiated Power Measurement

3.2.1 Description of the ERP/EIRP Measurement

The substitution method, in ANSI / TIA / EIA-603-C-2004, was used for ERP/EIRP measurement follows KDB 412172. The ERP of mobile transmitters must not exceed 7 Watts and the EIRP of mobile transmitters are limited to 2 Watts.

3.2.2 Measuring Instruments

See list of measuring instruments of this test report.

3.2.3 Test Procedures

The testing follows FCC KDB Publication No.412172

$$ERP/EIRP = P_T + G_T - L_C$$

P_T = transmitter output power, in dBW, dBm, or psd (power over a specified reference bandwidth);

G_T = gain of the transmitting antenna, in dBd (ERP) or dBi (EIRP);

L_C = signal attenuation in the connecting cable between the transmitter and antenna, in dB.

3.2.4 Test Result of ERP

GSM850 (GSM) Radiated Power ERP					
Frequency (MHz)	P_T (dBm)	G_T (dBi)	L_C (dB)	ERP (dBm)	ERP (W)
824.2	32.11	2.00	0	31.96	1.57
836.4	32.07	2.00	0	31.92	1.56
848.8	31.96	2.00	0	31.81	1.52

GSM850 (EDGE 8) Radiated Power ERP					
Frequency (MHz)	P_T (dBm)	G_T (dBi)	L_C (dB)	ERP (dBm)	ERP (W)
824.2	25.96	2.00	0	25.81	0.38
836.4	25.92	2.00	0	25.77	0.38
848.8	25.87	2.00	0	25.72	0.37

* $ERP = P_T$ (dBm) + G_T (dBi) - L_C (dB) - 2.15



3.2.5 Test Result of EIRP

GSM1900 (GSM) Radiated Power EIRP					
Frequency (MHz)	P _T (dBm)	G _T (dBi)	L _C (dB)	EIRP (dBm)	EIRP (W)
1850.20	28.55	2.00	0	30.55	1.14
1880.00	28.51	2.00	0	30.51	1.12
1909.80	28.46	2.00	0	30.46	1.11

GSM1900 (EDGE 8) Radiated Power EIRP					
Frequency (MHz)	P _T (dBm)	G _T (dBi)	L _C (dB)	EIRP (dBm)	EIRP (W)
1850.20	24.30	2.00	0	26.30	0.43
1880.00	24.34	2.00	0	26.34	0.43
1909.80	24.14	2.00	0	26.14	0.41

3.3 Occupied Bandwidth Measurement

3.3.1 Description of Occupied Bandwidth Measurement

The emission bandwidth is defined as the width of the signal between two points, located at the 2 sides of the carrier frequency, outside of which all emissions are attenuated at least 26 dB below the transmitter power.

3.3.2 Measuring Instruments

See list of measuring instruments of this test report.

3.3.3 Test Procedures

1. The EUT was connected to Spectrum Analyzer and Base Station via power divider.
2. The 99% and 26 dB occupied bandwidth (BW) of the middle channel for the highest RF powers were measured.

3.3.4 Test Setup

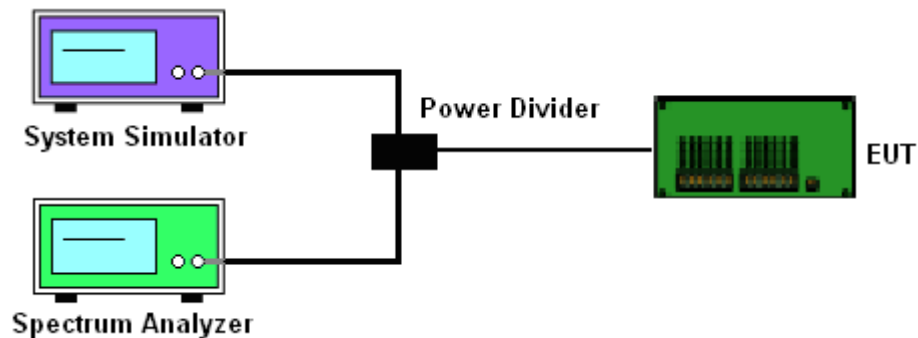



3.3.5 Test Result (Plots) of Occupied Bandwidth

Band :	GSM 850	Power Stage :	High
Test Mode :	GSM Link		

99% Occupied Bandwidth Plot on Channel 128

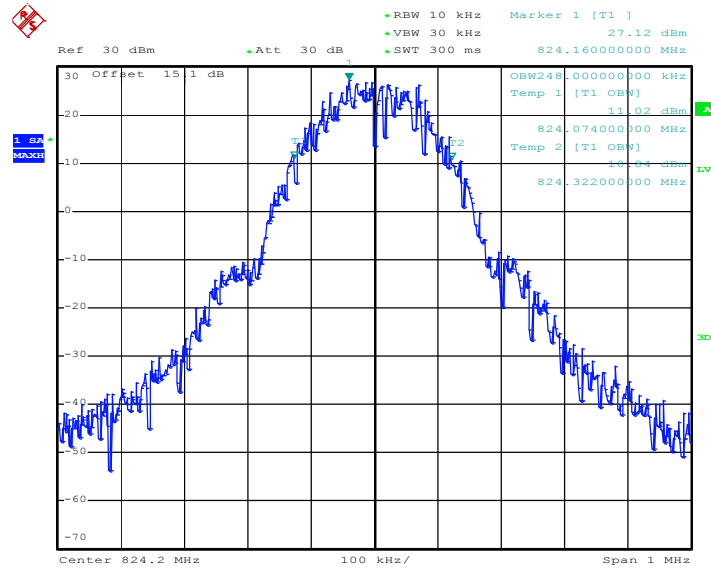

Date: 22.MAR.2012 10:17:31

26dB Bandwidth Plot on Channel 128

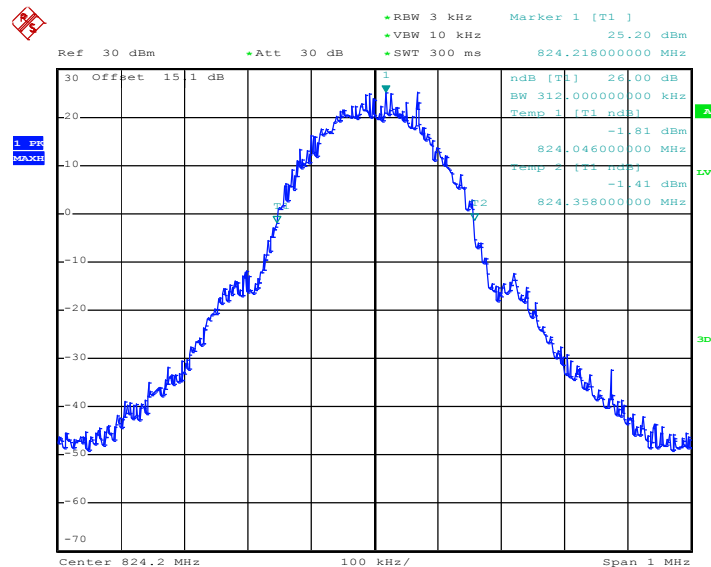

Date: 22.MAR.2012 10:16:11



99% Occupied Bandwidth Plot on Channel 189

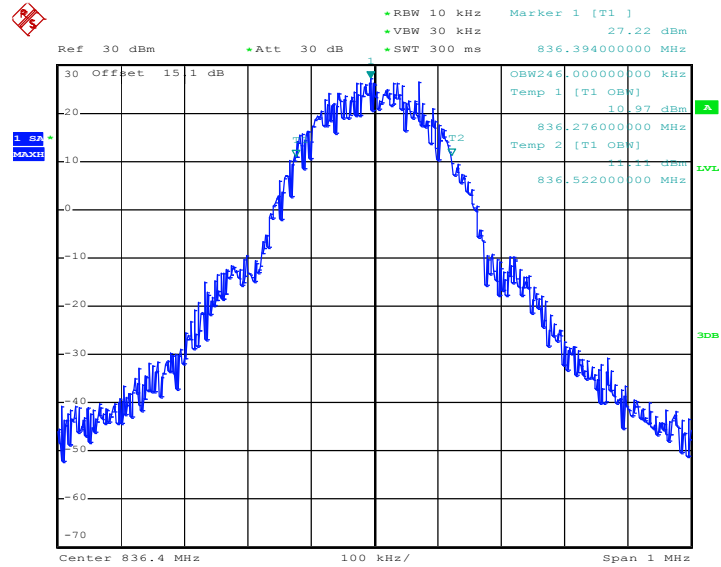

Date: 22.MAR.2012 10:17:57

26dB Bandwidth Plot on Channel 189

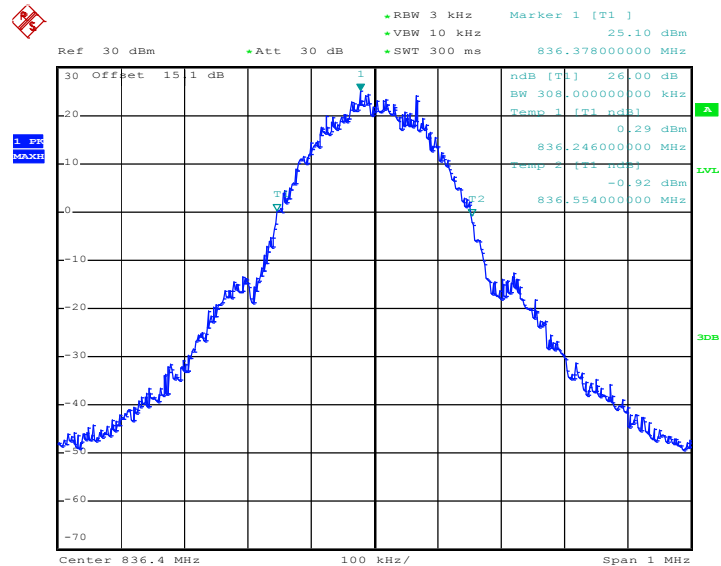

Date: 22.MAR.2012 10:16:38



99% Occupied Bandwidth Plot on Channel 251

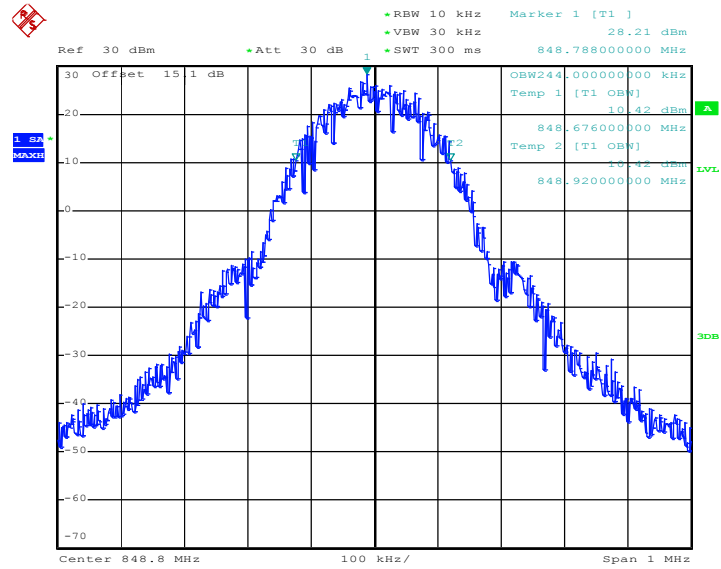

Date: 22.MAR.2012 10:18:23

26dB Bandwidth Plot on Channel 251

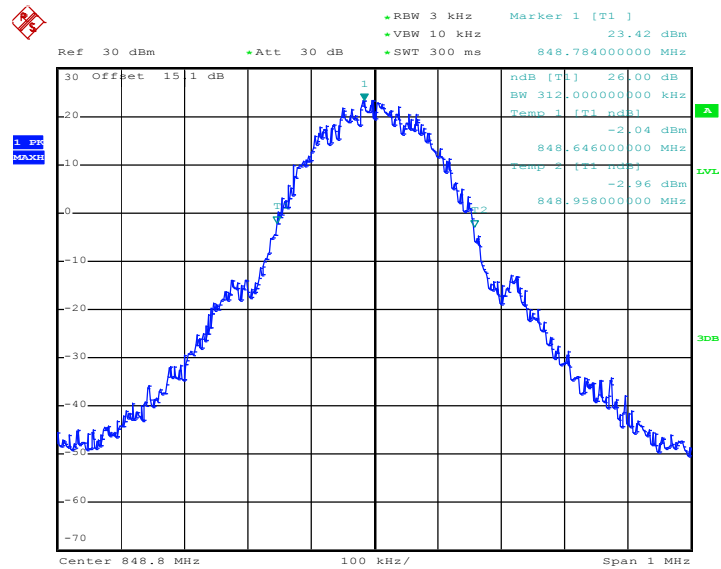

Date: 22.MAR.2012 10:17:04



Band :	GSM 850	Power Stage :	High
Test Mode :	EDGE 8 Link		

99% Occupied Bandwidth Plot on Channel 128

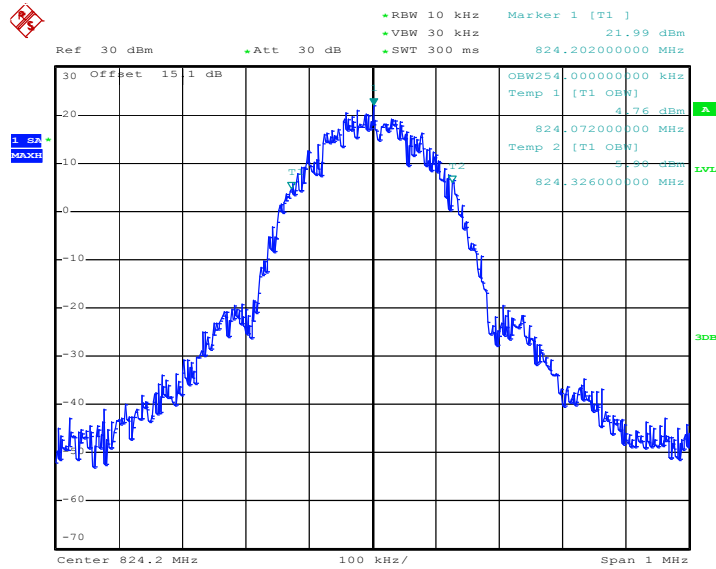

Date: 22.MAR.2012 10:41:50

26dB Bandwidth Plot on Channel 128

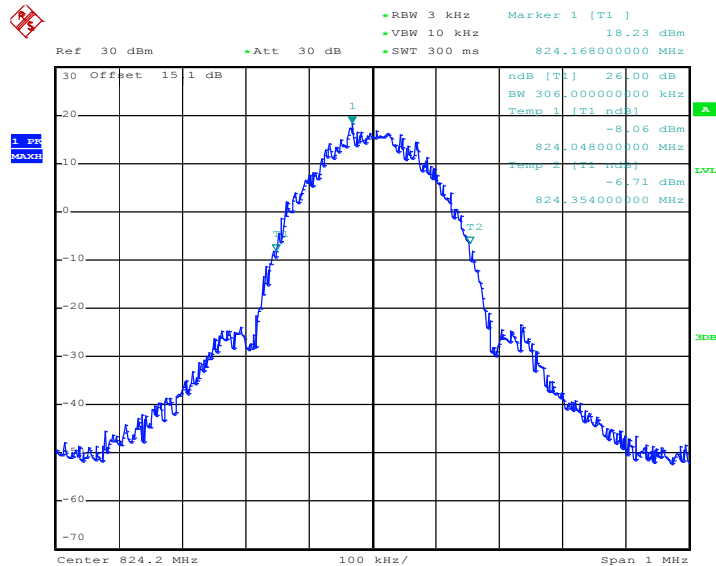

Date: 22.MAR.2012 10:40:30



99% Occupied Bandwidth Plot on Channel 189

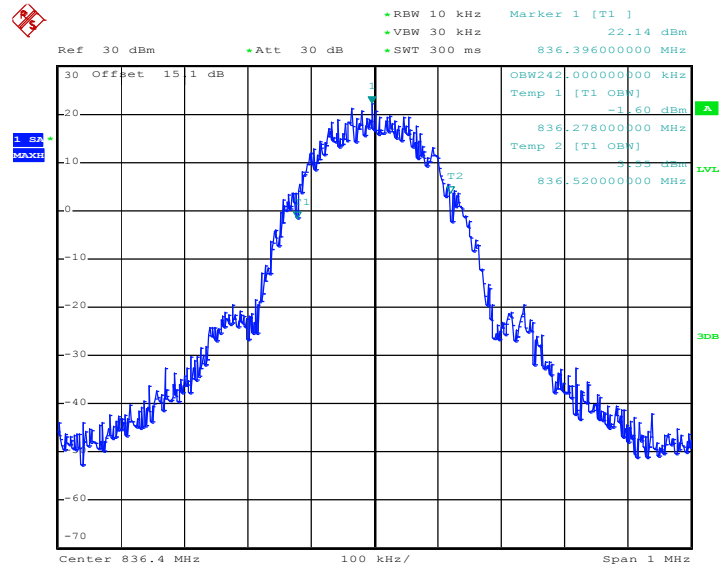

Date: 22.MAR.2012 10:42:16

26dB Bandwidth Plot on Channel 189

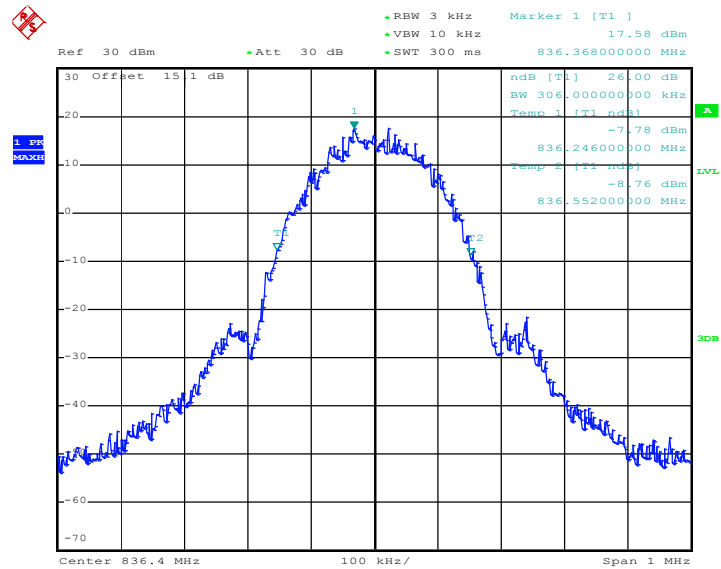

Date: 22.MAR.2012 10:40:57



99% Occupied Bandwidth Plot on Channel 251

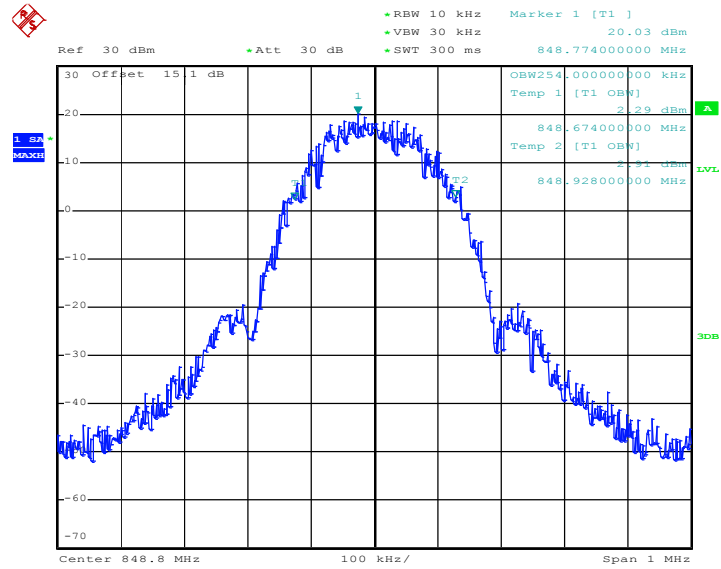

Date: 22.MAR.2012 10:42:42

26dB Bandwidth Plot on Channel 251

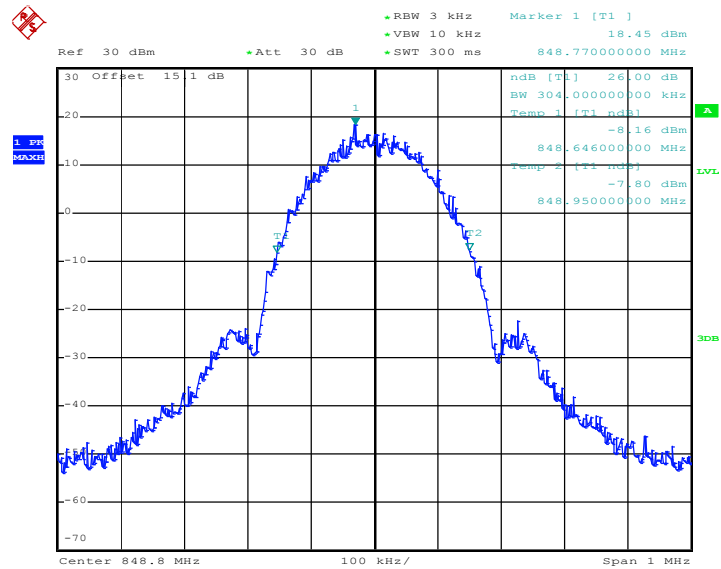

Date: 22.MAR.2012 10:41:23



Band :	GSM 1900	Power Stage :	High
Test Mode :	GSM Link		

99% Occupied Bandwidth Plot on Channel 512

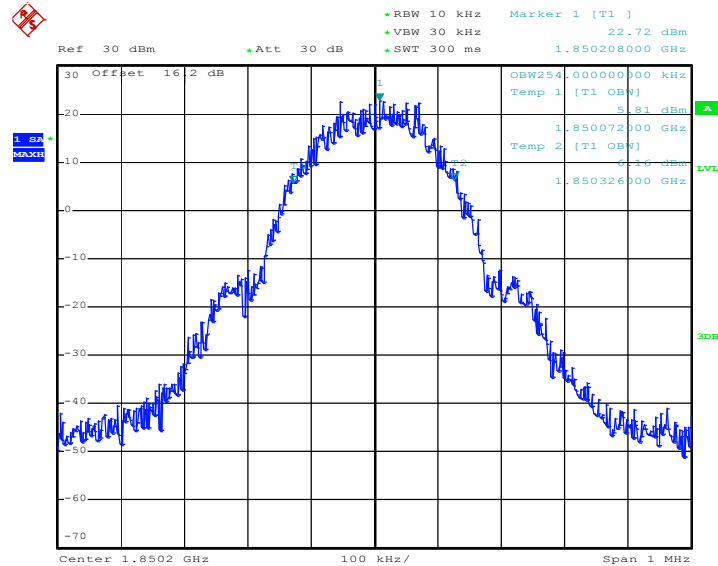

Date: 22.MAR.2012 11:46:53

26dB Bandwidth Plot on Channel 512

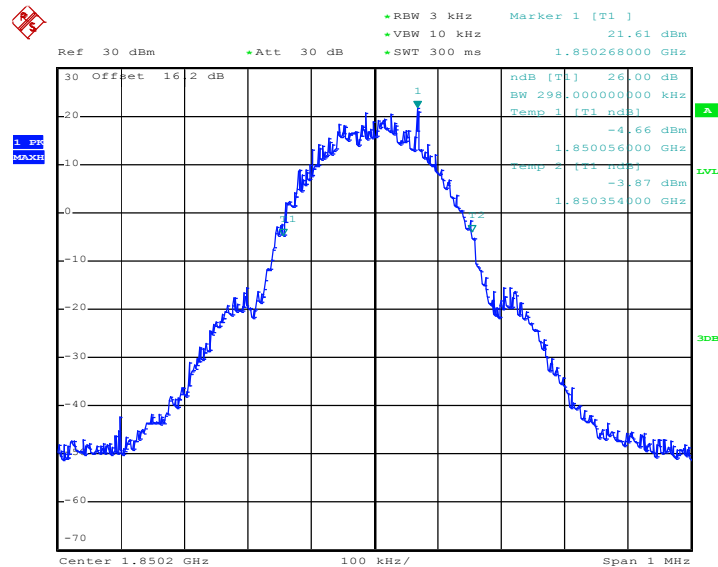

Date: 22.MAR.2012 11:45:34



99% Occupied Bandwidth Plot on Channel 661

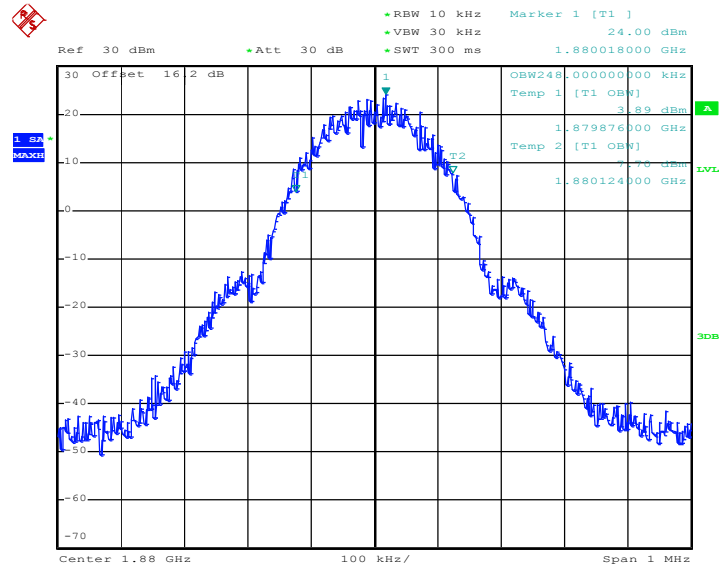

Date: 22.MAR.2012 11:47:19

26dB Bandwidth Plot on Channel 661

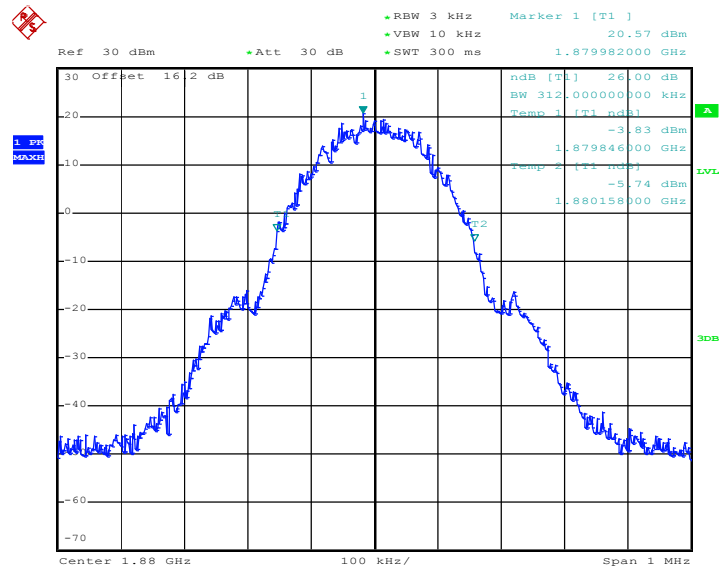

Date: 22.MAR.2012 11:46:00



99% Occupied Bandwidth Plot on Channel 810

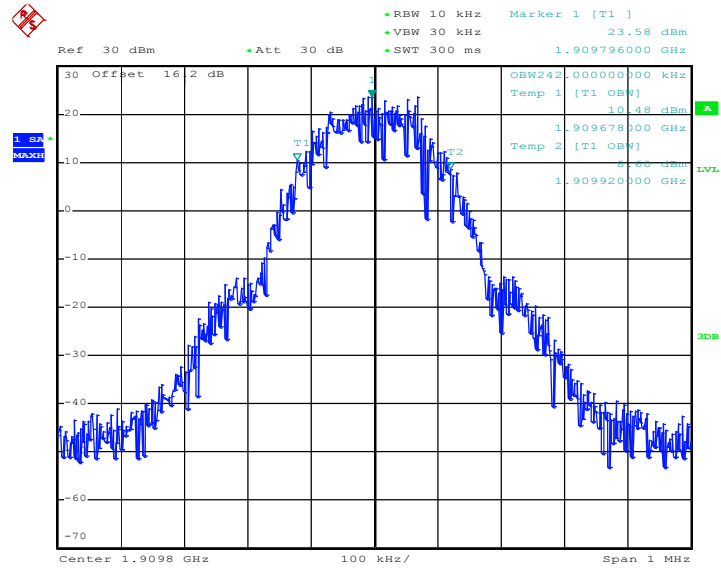

Date: 22.MAR.2012 11:47:45

26dB Bandwidth Plot on Channel 810

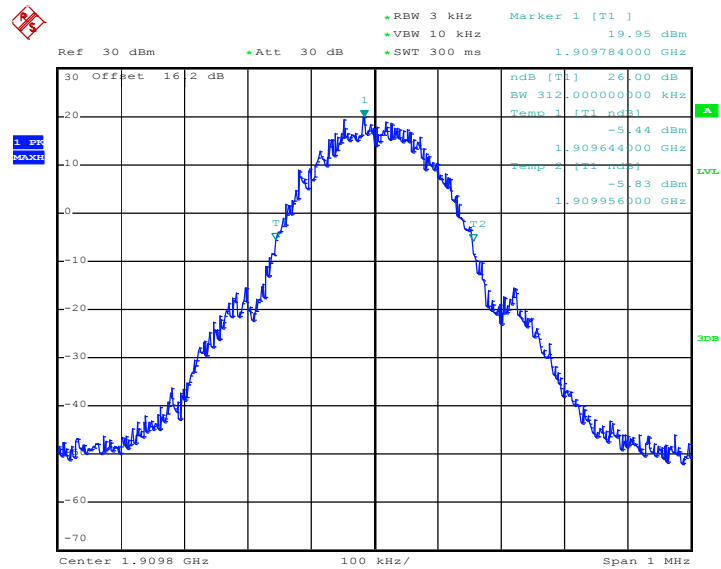

Date: 22.MAR.2012 11:46:26



Band :	GSM 1900	Power Stage :	High
Test Mode :	EDGE 8 Link		

99% Occupied Bandwidth Plot on Channel 512

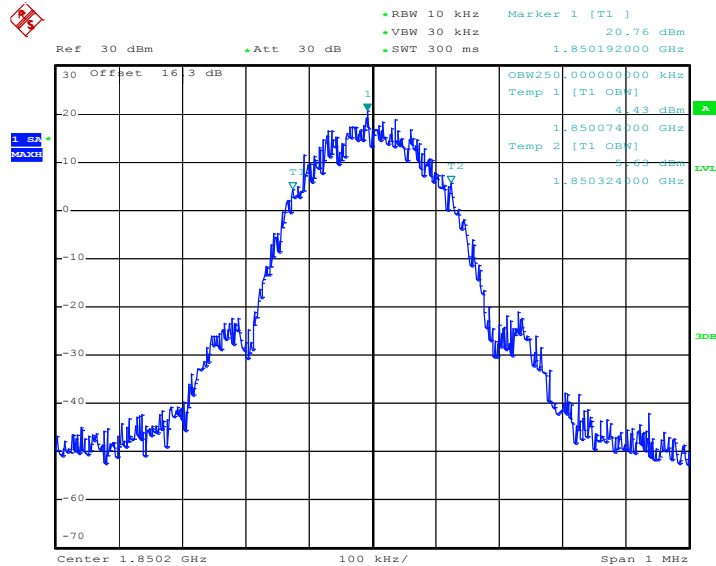

Date: 22.MAR.2012 14:24:54

26dB Bandwidth Plot on Channel 512

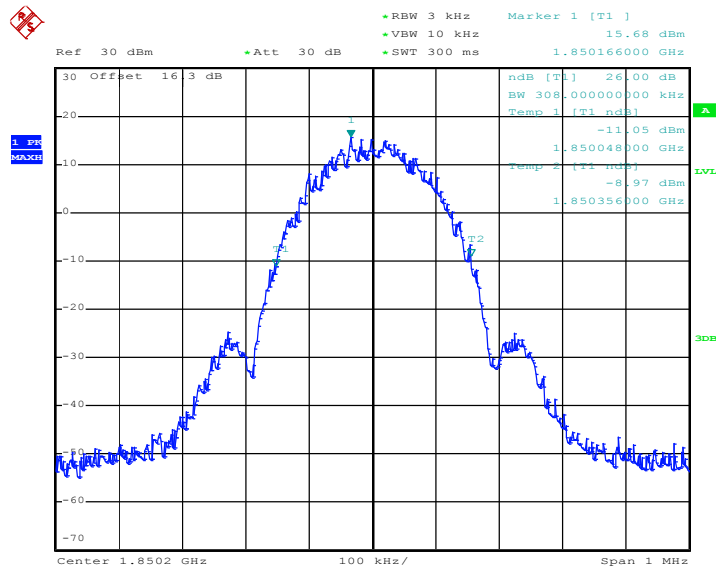

Date: 22.MAR.2012 14:23:35



99% Occupied Bandwidth Plot on Channel 661

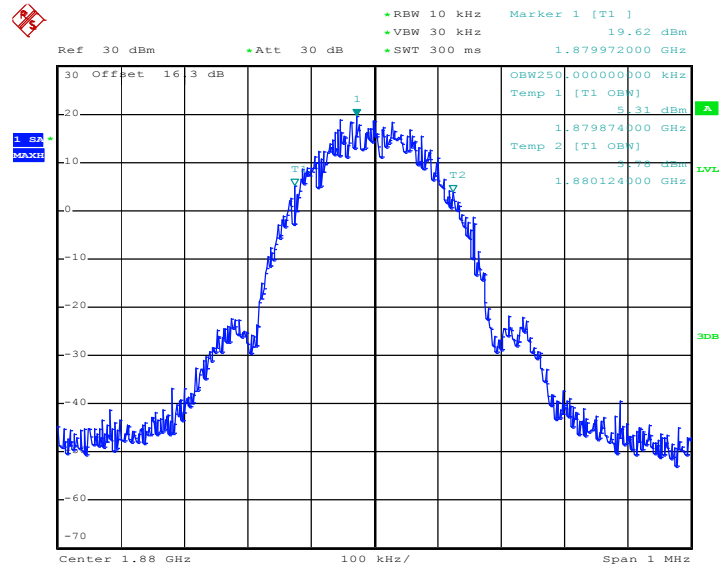

Date: 22.MAR.2012 14:25:20

26dB Bandwidth Plot on Channel 661

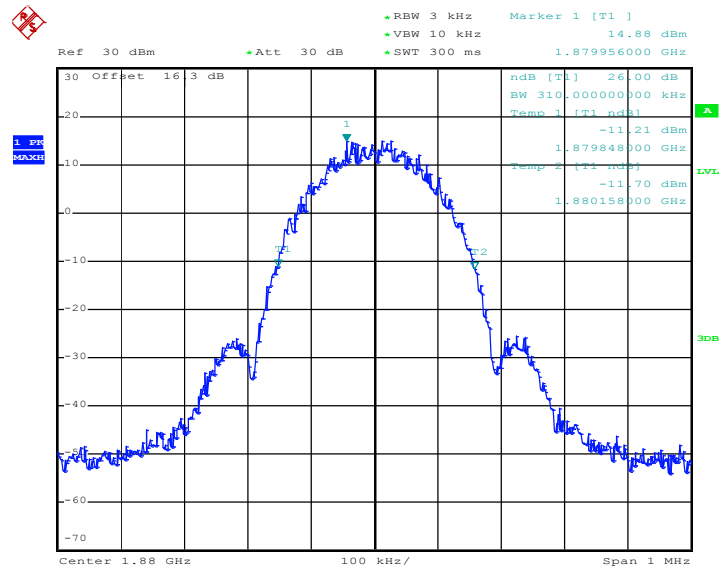

Date: 22.MAR.2012 14:24:01



99% Occupied Bandwidth Plot on Channel 810

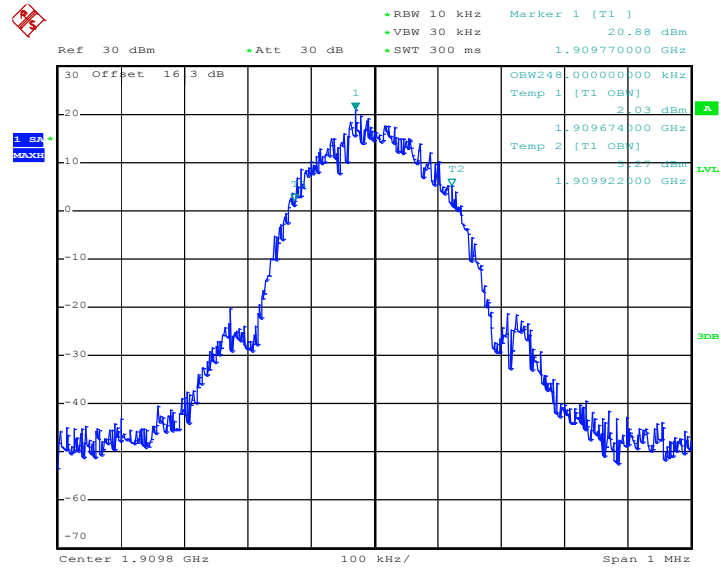

Date: 22.MAR.2012 14:25:46

26dB Bandwidth Plot on Channel 810

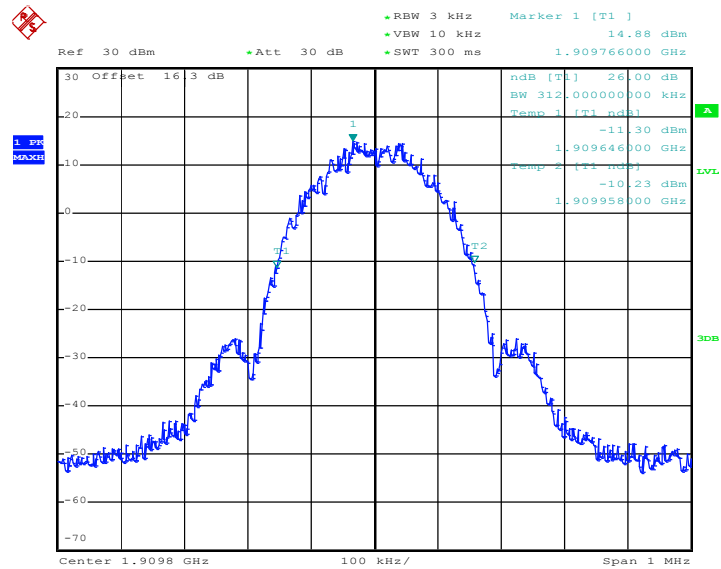

Date: 22.MAR.2012 14:24:27

3.4 Band Edge Measurement

3.4.1 Description of Band Edge Measurement

The power of any emission outside of the authorized operating frequency ranges must be lower than the transmitter power (P) by a factor of at least $43 + 10 \log (P)$ dB.

3.4.2 Measuring Instruments

See list of measuring instruments of this test report.

3.4.3 Test Procedures

1. The EUT was connected to Spectrum Analyzer and Base Station via power divider.
2. The band edges of low and high channels for the highest RF powers were measured. Setting RBW as roughly $BW/100$.

3.4.4 Test Setup

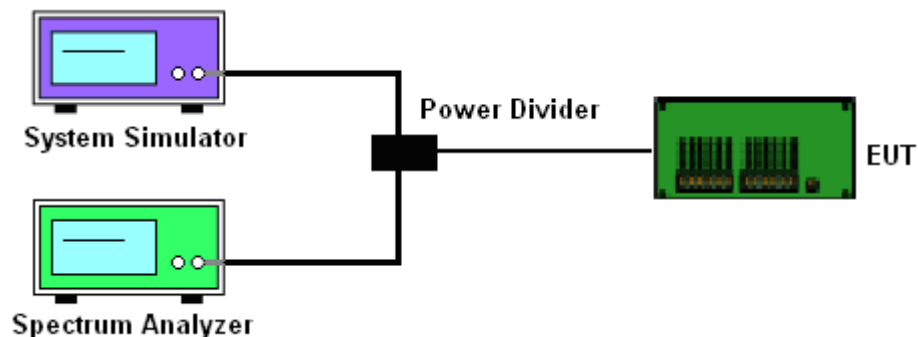

3.4.5 Test Result (Plots) of Conducted Band Edge

Band :	GSM850	Power Stage :	High
Test Mode :	GSM Link	Maximum 26dB Bandwidth :	0.312MHz
Correction Factor :	0.17dB	Measurement Value :	-18.98dBm
Band Edge :	-18.81dBm		

Lower Band Edge Plot on Channel 128

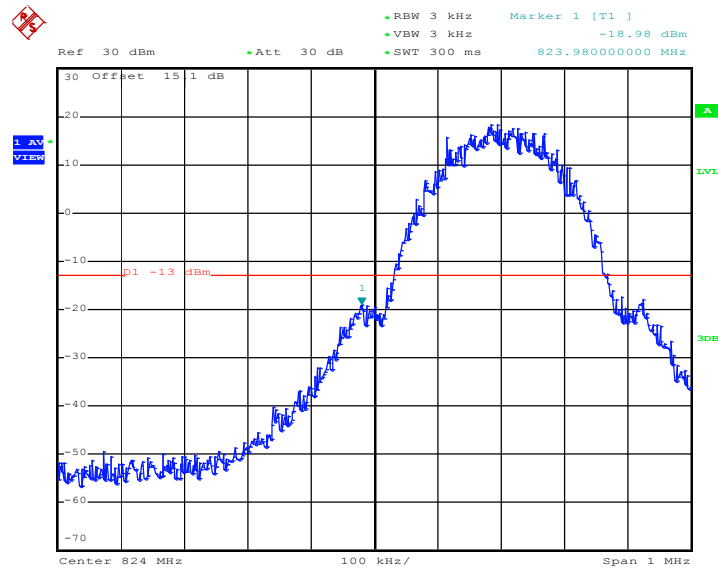

Date: 22.MAR.2012 10:19:51

1. Correction Factor(dB)= $10\log(1\% \text{ Emission BW/RBW})$
2. Band Edge= Measurement Value + Correction Factor(dB)



Band :	GSM850	Power Stage :	High
Test Mode :	GSM Link	Maximum 26dB Bandwidth :	0.312MHz
Correction Factor :	0.17dB	Measurement Value :	-16.96dBm
Band Edge :	-16.79dBm		

Higher Band Edge Plot on Channel 251

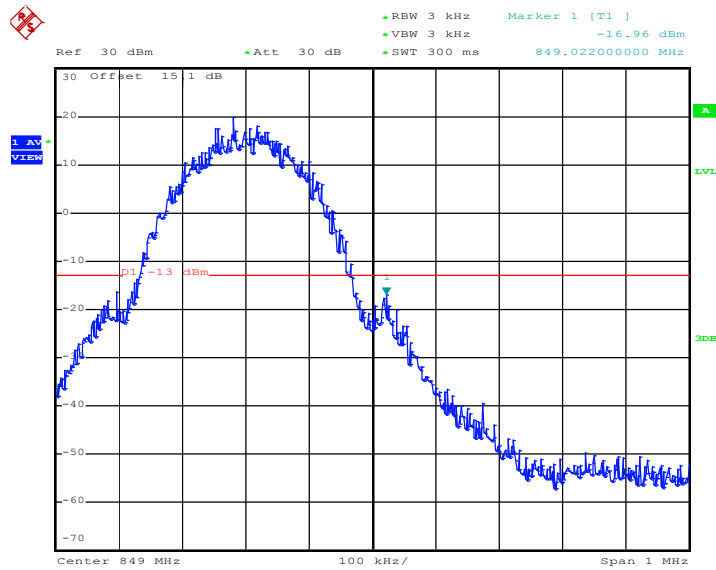

Date: 22.MAR.2012 10:20:18

1. Correction Factor(dB)= $10\log(1\% \text{ Emission BW/RBW})$
2. Band Edge= Measurement Value + Correction Factor(dB)



Band :	GSM850	Power Stage :	High
Test Mode :	EDGE 8 Link	Maximum 26dB Bandwidth :	0.306MHz
Correction Factor :	0.09dB	Measurement Value :	-28.65dBm
Band Edge :	-28.56dBm		

Lower Band Edge Plot on Channel 128

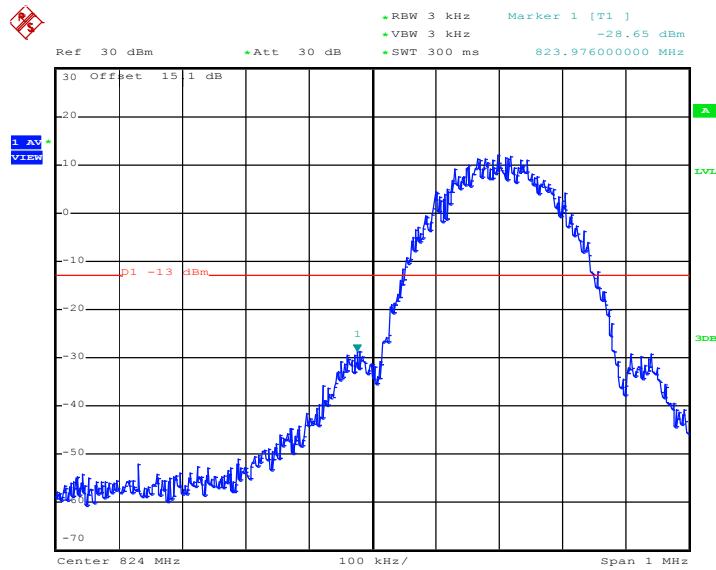

Date: 22.MAR.2012 10:44:08

1. Correction Factor(dB)= $10\log(1\% \text{ Emission BW/RBW})$
2. Band Edge= Measurement Value + Correction Factor(dB)



Band :	GSM850	Power Stage :	High
Test Mode :	EDGE 8 Link	Maximum 26dB Bandwidth :	0.306MHz
Correction Factor :	0.09dB	Measurement Value :	-28.33dBm
Band Edge :	-28.24dBm		

Higher Band Edge Plot on Channel 251

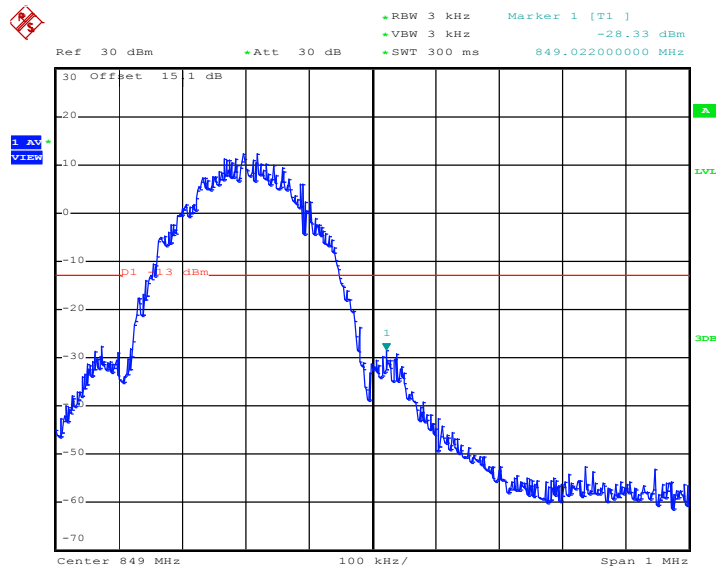

Date: 22.MAR.2012 10:44:35

- 1. Correction Factor(dB)= 10log(1% Emission BW/RBW)
- 2. Band Edge= Measurement Value + Correction Factor(dB)



Band :	GSM1900	Power Stage :	High
Test Mode :	GSM Link	Maximum 26dB Bandwidth :	0.312MHz
Correction Factor :	0.17dB	Measurement Value :	-20.91dBm
Band Edge :	-20.74dBm		

Lower Band Edge Plot on Channel 512

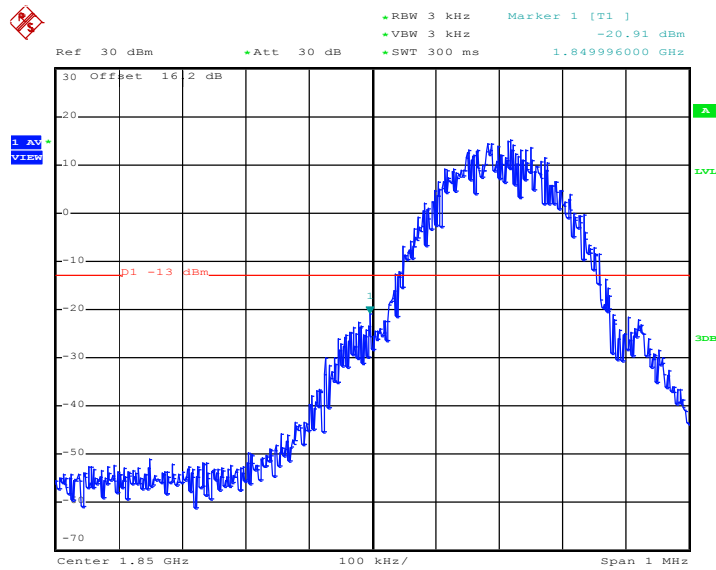

Date: 22.MAR.2012 11:49:11

1. Correction Factor(dB)= $10\log(1\% \text{ Emission BW/RBW})$
2. Band Edge= Measurement Value + Correction Factor(dB)



Band :	GSM1900	Power Stage :	High
Test Mode :	GSM Link	Maximum 26dB Bandwidth :	0.312MHz
Correction Factor :	0.17dB	Measurement Value :	-21.44dBm
Band Edge :	-21.27dBm		

Higher Band Edge Plot on Channel 810

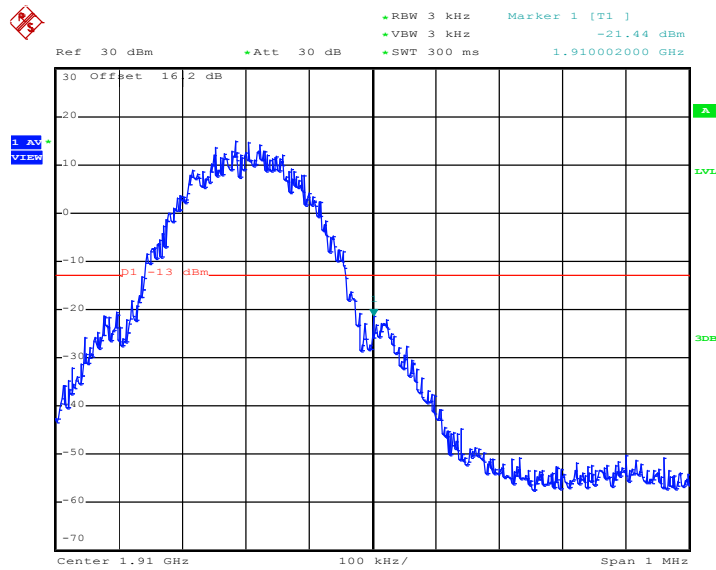

Date: 22.MAR.2012 11:49:37

1. Correction Factor(dB)= 10log(1% Emission BW/RBW)
2. Band Edge= Measurement Value + Correction Factor(dB)



Band :	GSM1900	Power Stage :	High
Test Mode :	EDGE 8 Link	Maximum 26dB Bandwidth :	0.312MHz
Correction Factor :	0.17dB	Measurement Value :	-29.65dBm
Band Edge :	-29.48dBm		

Lower Band Edge Plot on Channel 512

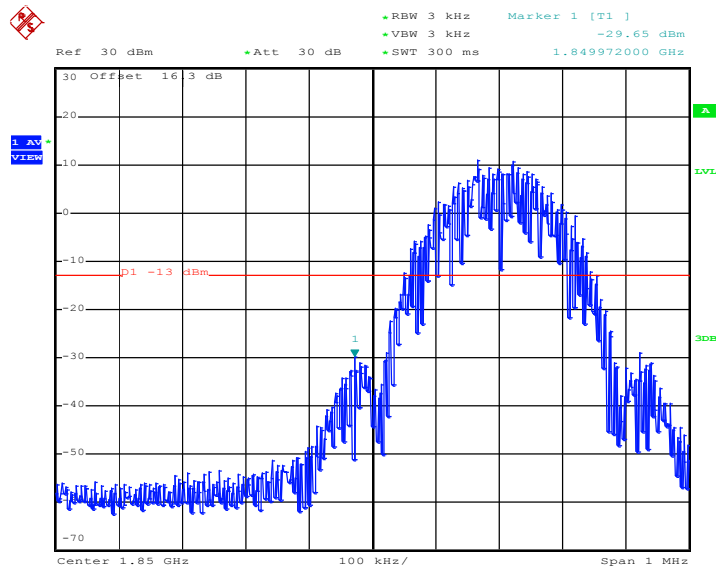

Date: 22.MAR.2012 14:27:13

1. Correction Factor(dB)= $10\log(1\% \text{ Emission BW/RBW})$
2. Band Edge= Measurement Value + Correction Factor(dB)



Band :	GSM1900	Power Stage :	High
Test Mode :	EDGE 8 Link	Maximum 26dB Bandwidth :	0.312MHz
Correction Factor :	0.17dB	Measurement Value :	-31.50dBm
Band Edge :	-31.33dBm		

Higher Band Edge Plot on Channel 810

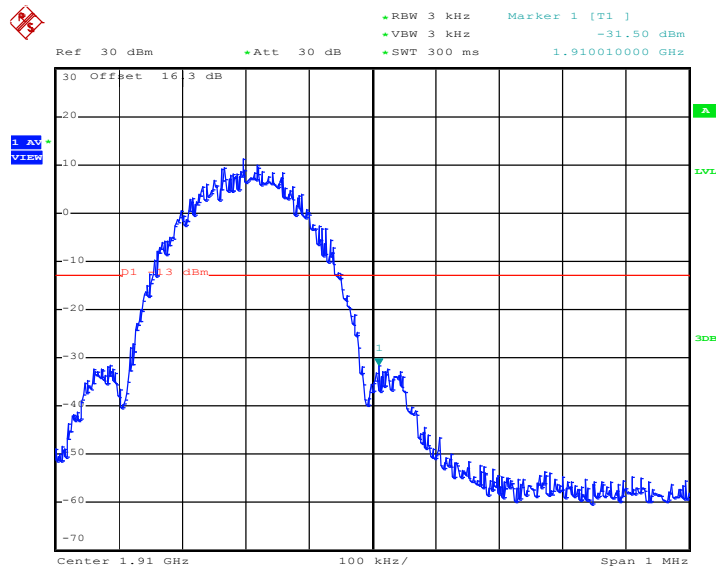

Date: 22.MAR.2012 14:27:39

1. Correction Factor(dB)= 10log(1% Emission BW/RBW)
2. Band Edge= Measurement Value + Correction Factor(dB)

3.5 Conducted Emission Measurement

3.5.1 Description of Conducted Emission Measurement

The power of any emission outside of the authorized operating frequency ranges must be lower than the transmitter power (P) by a factor of at least $43 + 10 \log (P)$ dB.

It is measured by means of a calibrated spectrum analyzer and scanned from 30 MHz up to a frequency including its 10th harmonic.

3.5.2 Measuring Instruments

See list of measuring instruments of this test report.

3.5.3 Test Procedures

1. The EUT was connected to spectrum analyzer and base station via power divider.
2. The middle channel for the highest RF power within the transmitting frequency was measured.
3. The conducted spurious emission for the whole frequency range was taken.

3.5.4 Test Setup

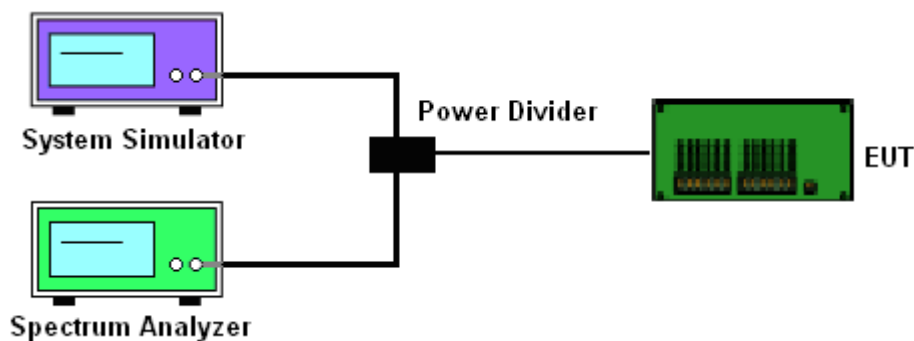



3.5.5 Test Result (Plots) of Conducted Emission

Band :	GSM850	Channel :	CH189
Test Mode :	GSM Link		

Conducted Emission Plot between 30MHz ~ 1GHz

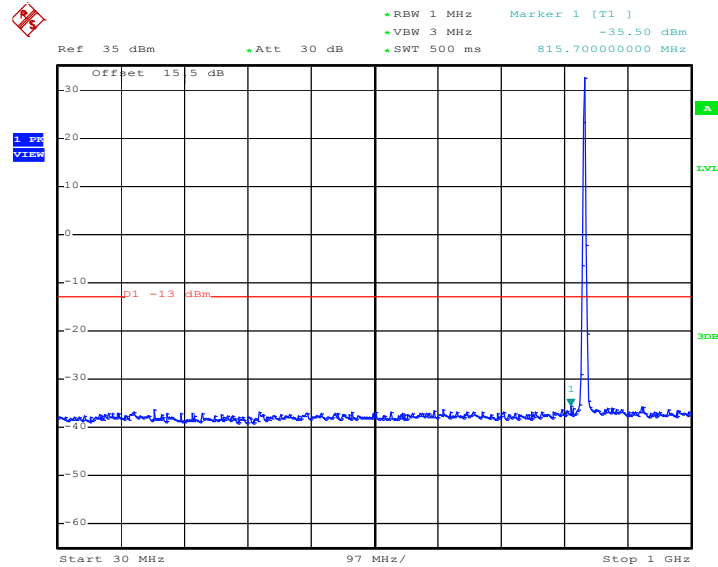

Date: 22.MAR.2012 10:35:38

Conducted Emission Plot between 1GHz ~ 3GHz

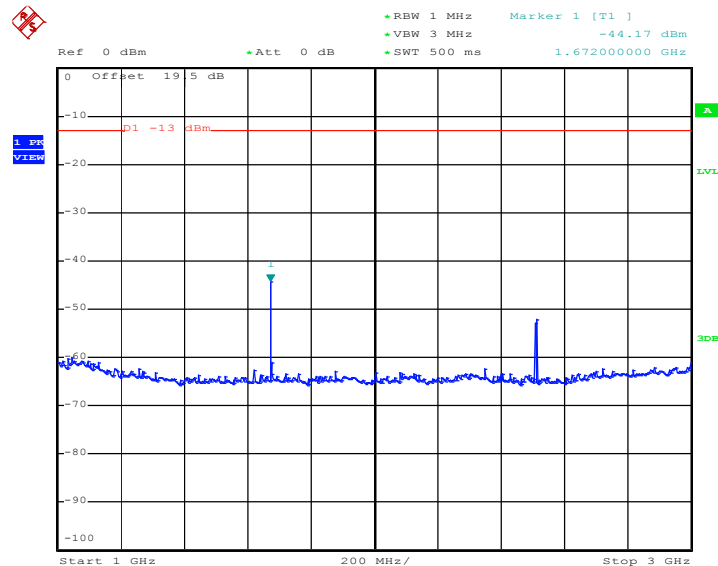

Date: 22.MAR.2012 10:36:01



Conducted Emission Plot between 3GHz ~ 7GHz

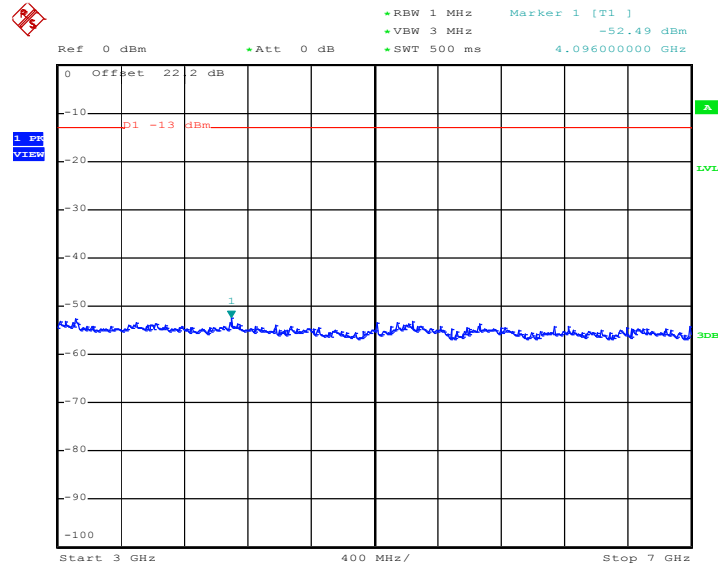

Date: 22.MAR.2012 10:36:13

Conducted Emission Plot between 7GHz ~ 9GHz

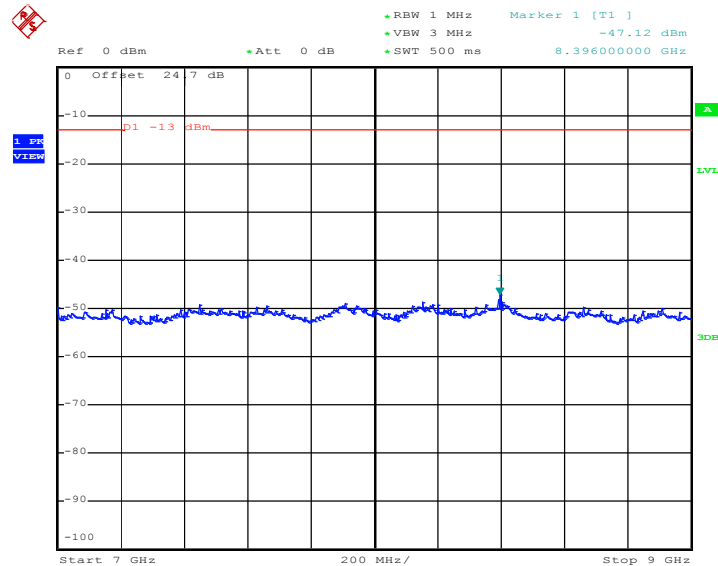

Date: 22.MAR.2012 10:36:26



Band :	GSM850	Channel :	CH189
Test Mode :	EDGE 8 Link		

Conducted Emission Plot between 30MHz ~ 1GHz

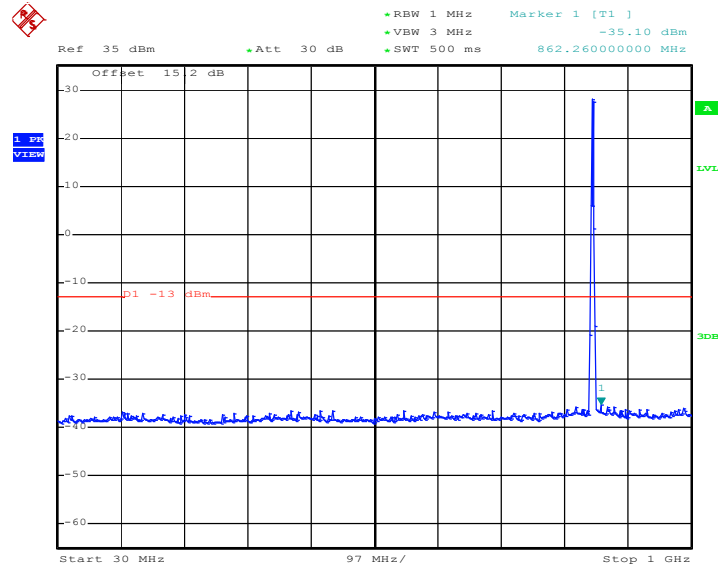

Date: 22.MAR.2012 10:51:21

Conducted Emission Plot between 1GHz ~ 3GHz

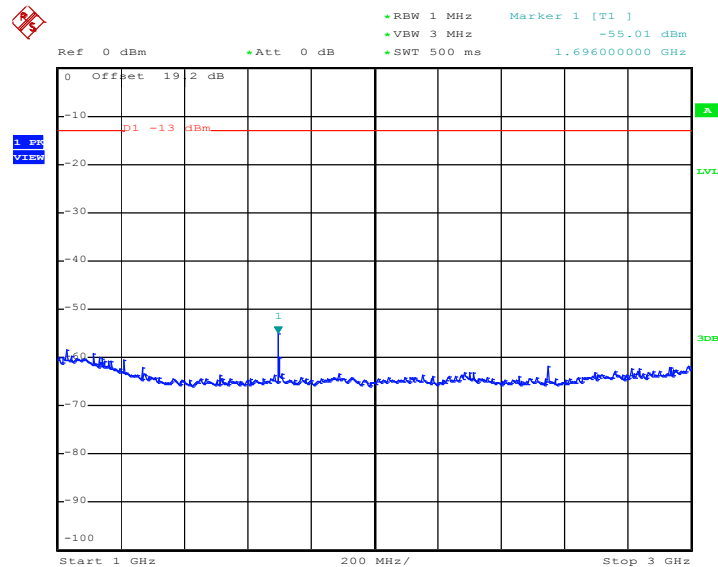

Date: 22.MAR.2012 10:51:43



Conducted Emission Plot between 3GHz ~ 7GHz

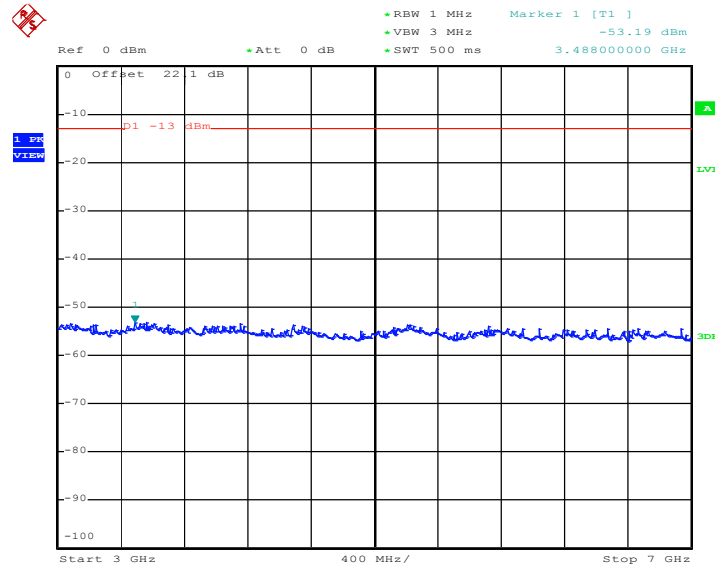

Date: 22.MAR.2012 10:51:55

Conducted Emission Plot between 7GHz ~ 9GHz

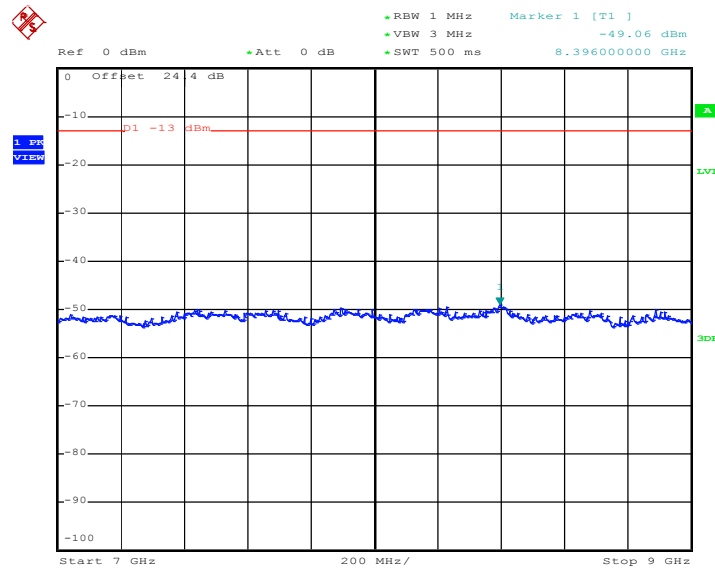

Date: 22.MAR.2012 10:52:08



Band :	GSM1900	Channel :	CH661
Test Mode :	GSM Link		

Conducted Emission Plot between 30MHz ~ 1GHz

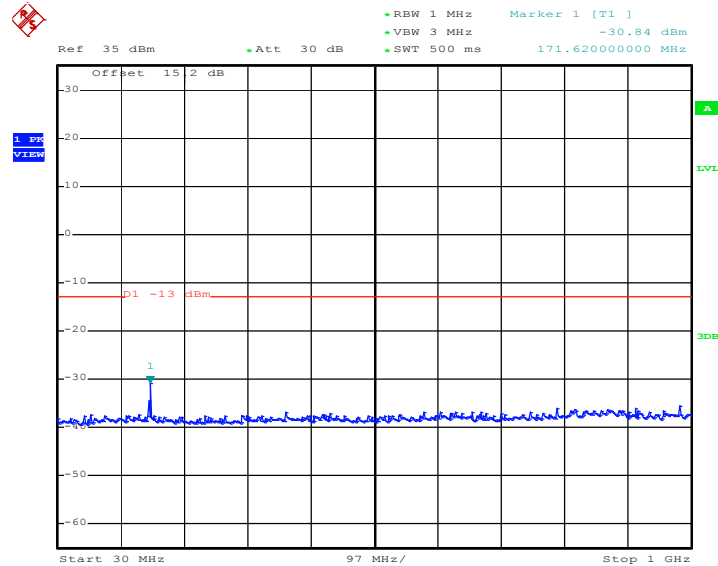

Date: 22.MAR.2012 11:51:15

Conducted Emission Plot between 1GHz ~ 3GHz

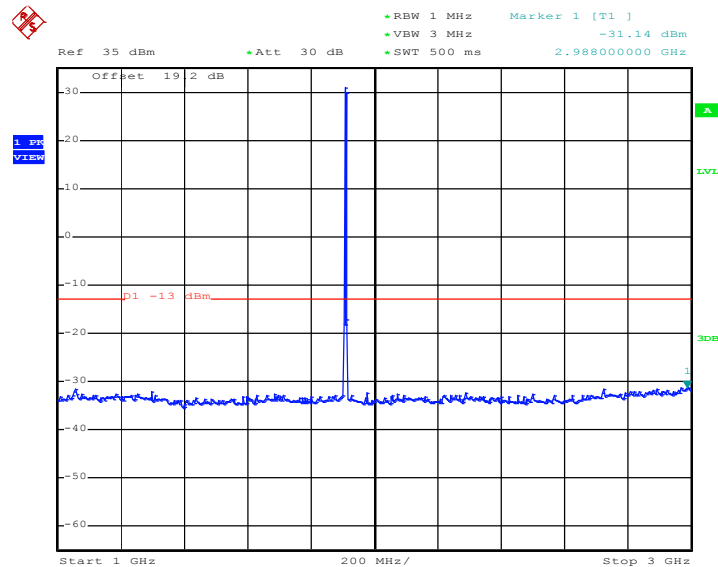

Date: 22.MAR.2012 11:51:27



Conducted Emission Plot between 3GHz ~ 7GHz

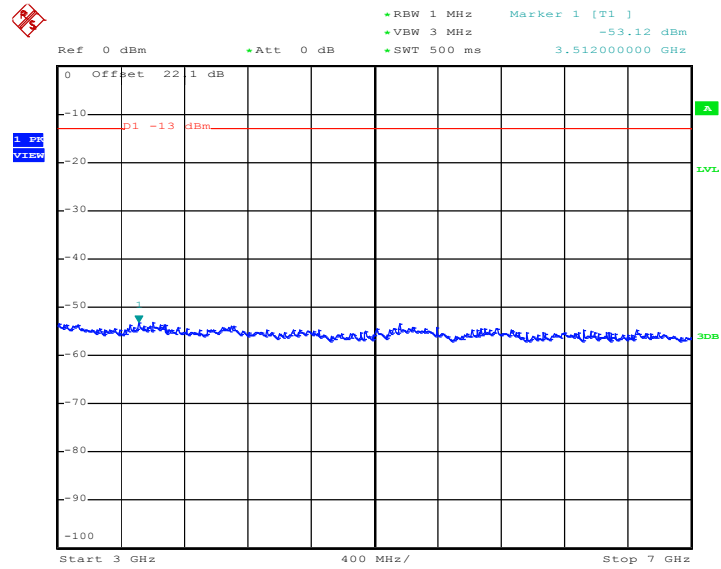

Date: 22.MAR.2012 11:51:50

Conducted Emission Plot between 7GHz ~ 13.6GHz

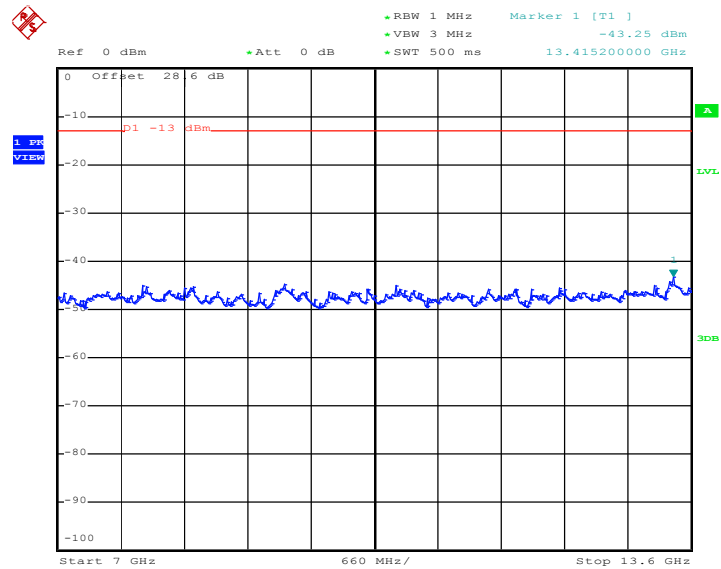

Date: 22.MAR.2012 11:52:02



Conducted Emission Plot between 13.6GHz ~ 19.1GHz

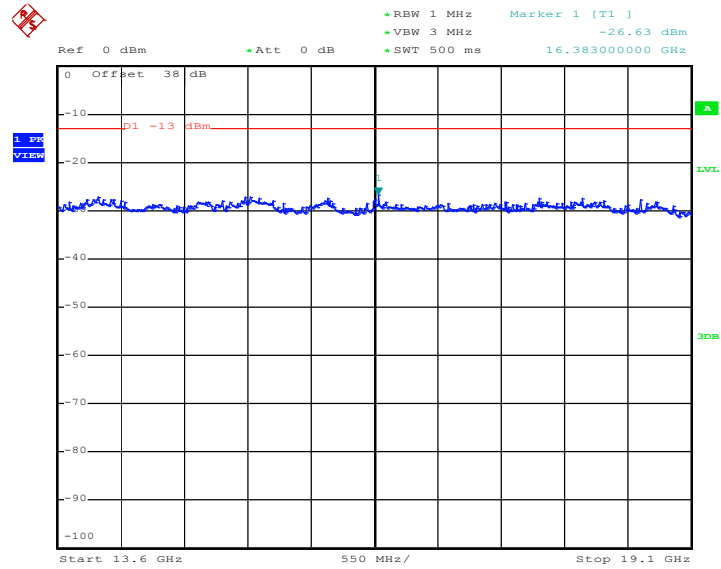

Date: 22.MAR.2012 11:52:15



Band :	GSM1900	Channel :	CH661
Test Mode :	EDGE 8 Link		

Conducted Emission Plot between 30MHz ~ 1GHz

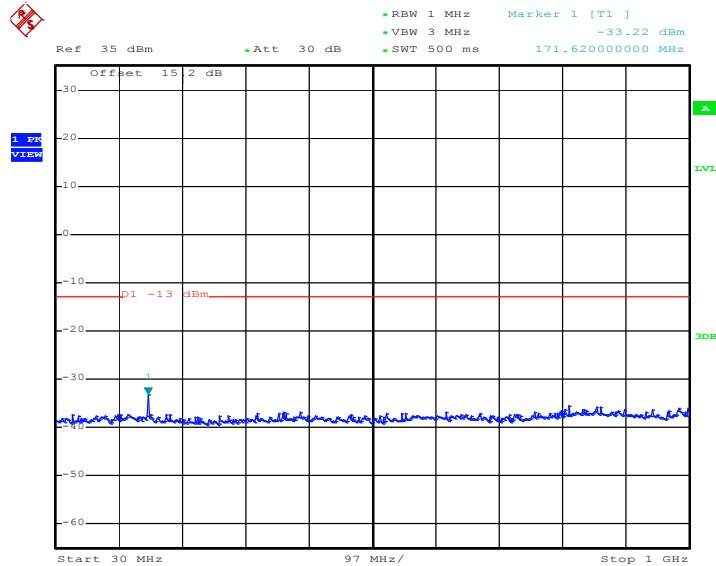

Date: 22.MAR.2012 14:29:27

Conducted Emission Plot between 1GHz ~ 3GHz

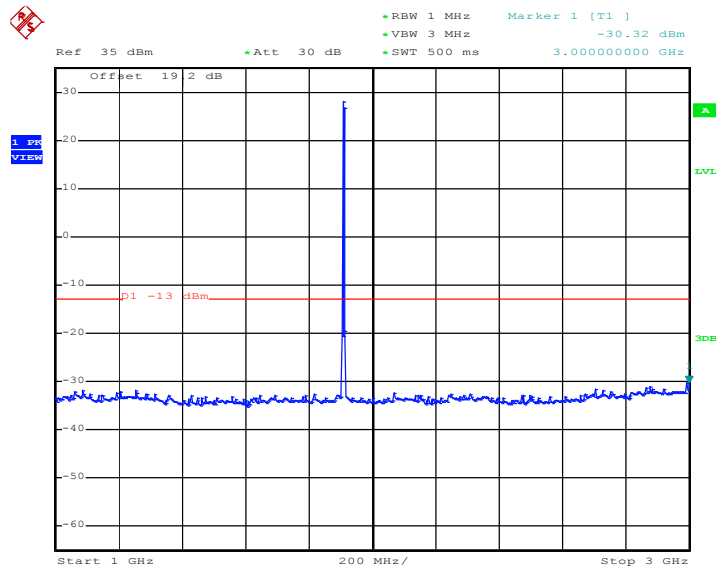

Date: 22.MAR.2012 14:29:39



Conducted Emission Plot between 3GHz ~ 7GHz

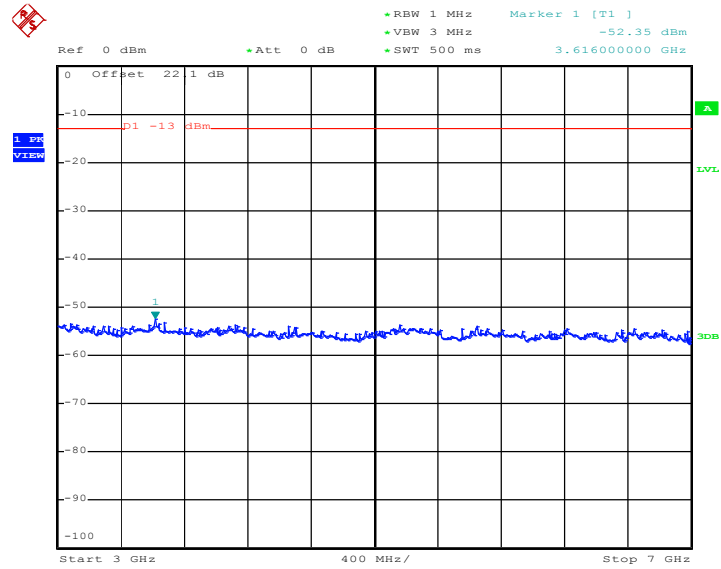

Date: 22.MAR.2012 14:30:07

Conducted Emission Plot between 7GHz ~ 13.6GHz

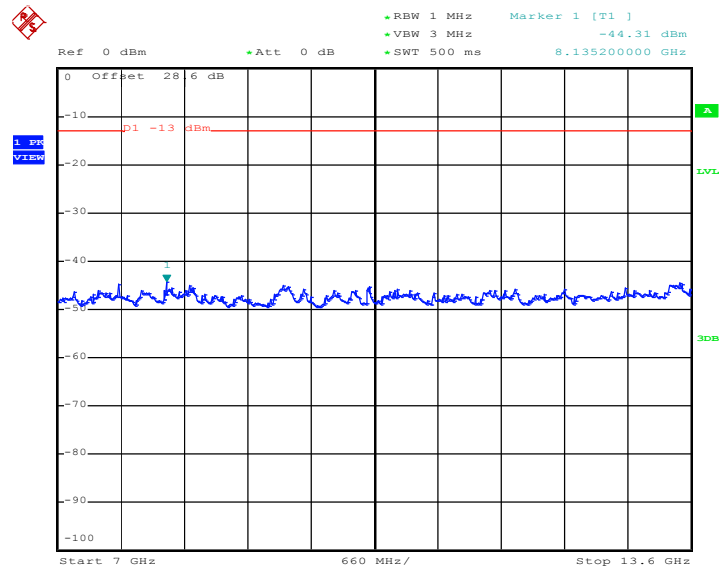

Date: 22.MAR.2012 14:30:19



Conducted Emission Plot between 13.6GHz ~ 19.1GHz

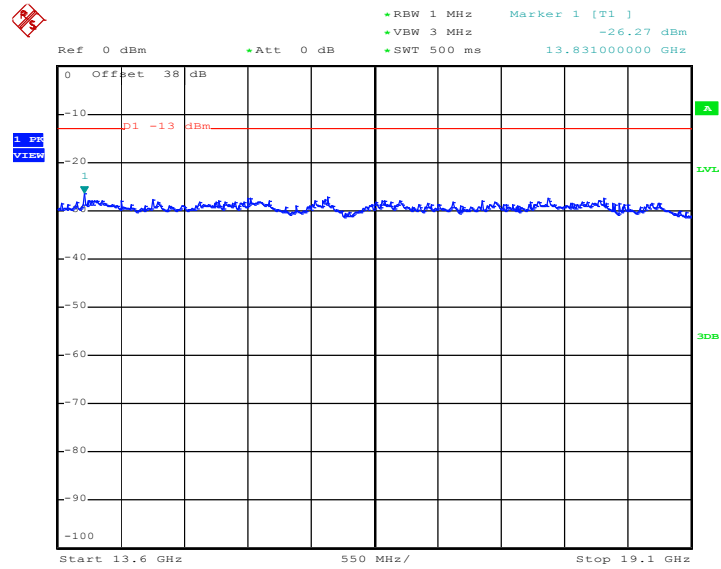

Date: 22.MAR.2012 14:30:32

3.6 Field Strength of Spurious Radiation Measurement

3.6.1 Description of Field Strength of Spurious Radiated Measurement

The radiated spurious emission was measured by substitution method according to ANSI / TIA / EIA-603-C-2004. The power of any emission outside of the authorized operating frequency ranges must be attenuated below the transmitter power (P) by a factor of at least $43 + 10 \log (P)$ dB. The spectrum is scanned from 30 MHz up to a frequency including its 10th harmonic.

3.6.2 Measuring Instruments

See list of measuring instruments of this test report.

3.6.3 Test Procedures

1. The EUT was placed on a rotatable wooden table with 0.8 meter about ground.
2. The EUT was set 3 meters from the receiving antenna, which was mounted on the antenna tower.
3. The table was rotated 360 degrees to determine the position of the highest spurious emission.
4. The height of the receiving antenna is varied between one meter and four meters to search the maximum spurious emission for both horizontal and vertical polarizations.
5. Make the measurement with the spectrum analyzer's RBW = 1MHz, VBW = 3MHz, Sweep = 500ms, Taking the record of maximum spurious emission.
6. A horn antenna was substituted in place of the EUT and was driven by a signal generator.
7. Tune the output power of signal generator to the same emission level with EUT maximum spurious emission.
8. Taking the record of output power at antenna port.
9. Repeat step 7 to step 8 for another polarization.
10. $EIRP (dBm) = S.G. Power - Tx Cable Loss + Tx Antenna Gain$
11. $ERP (dBm) = EIRP - 2.15$

3.6.4 Test Setup

For radiated emissions below 30MHz

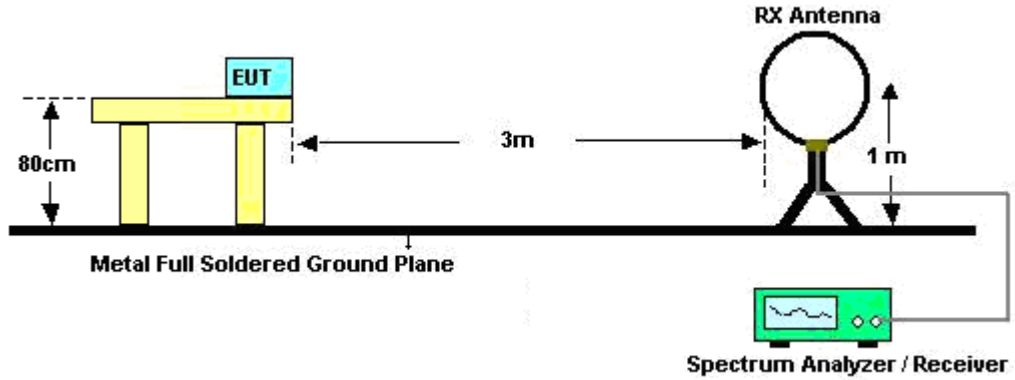

For radiated emissions above 30MHz

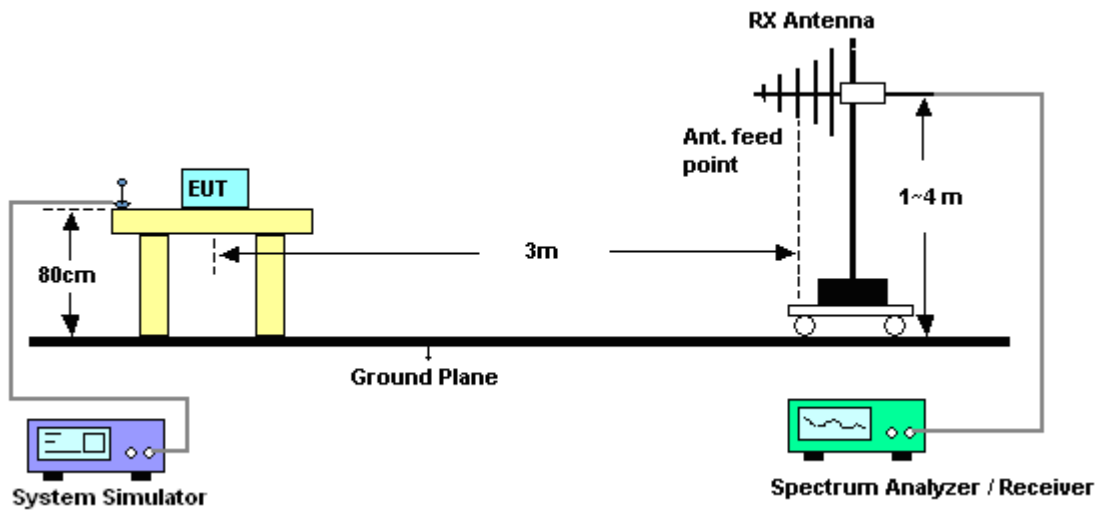

3.6.5 Test Results of Radiated Emissions (9 KHz ~ 30 MHz)

The low frequency, which started from 9 KHz to 30MHz, was pre-scanned and the result which was 20dB lower than the limit line per 15.31(o) was not reported.



3.6.6 Test Result of Field Strength of Spurious Radiated

Band :	GSM850	Temperature :	20~22°C
Test Mode :	GSM Link	Relative Humidity :	40~42%
Test Engineer :	David Ke	Polarization :	Horizontal
Remark :	Spurious emissions within 30-1000MHz were found more than 20dB below limit line.		

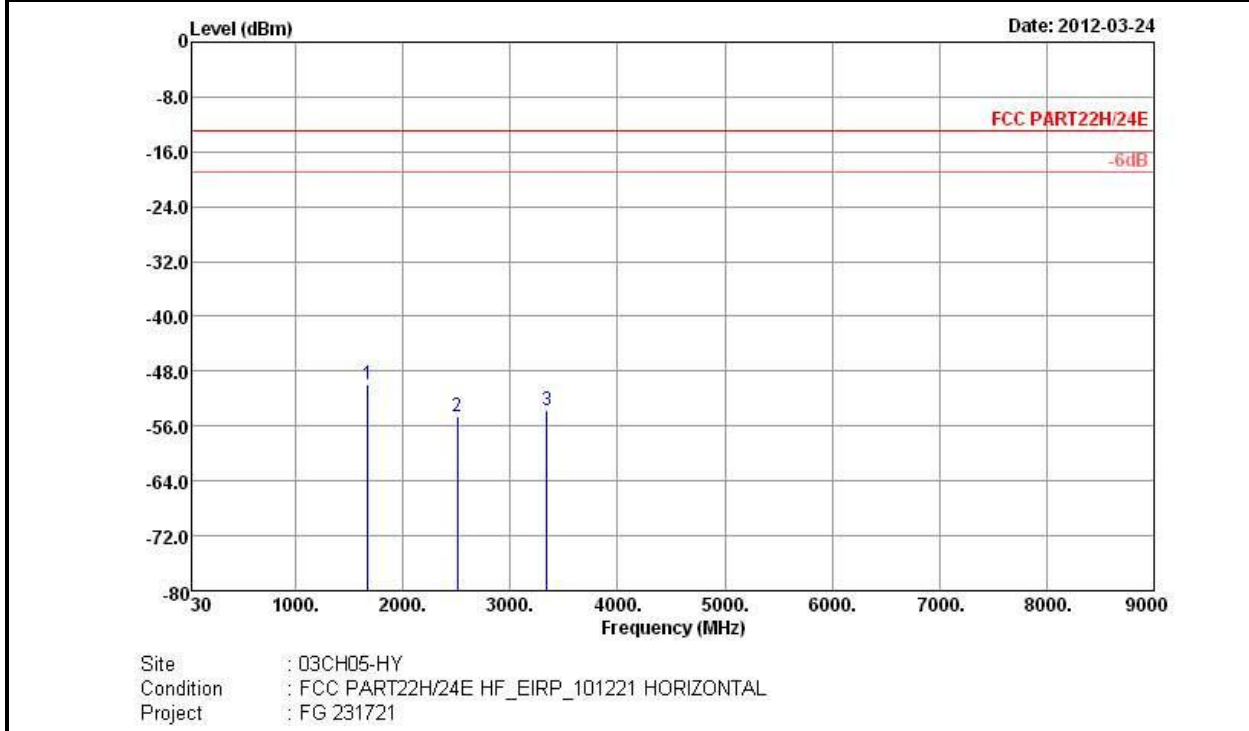

Frequency (MHz)	ERP (dBm)	Limit (dBm)	Over Limit (dB)	SPA Reading (dBm)	S.G. Power (dBm)	TX Cable loss (dB)	TX Antenna Gain (dBi)	Polarization (H/V)	Result
1672	-49.81	-13	-36.81	-55.83	-51	2.15	5.49	H	Pass
2509	-54.56	-13	-41.56	-63.99	-56.45	2.38	6.41	H	Pass
3345	-53.67	-13	-40.67	-65.26	-57	2.86	8.34	H	Pass



Band :	GSM850	Temperature :	20~22°C
Test Mode :	GSM Link	Relative Humidity :	40~42%
Test Engineer :	David Ke	Polarization :	Vertical
Remark :	Spurious emissions within 30-1000MHz were found more than 20dB below limit line.		

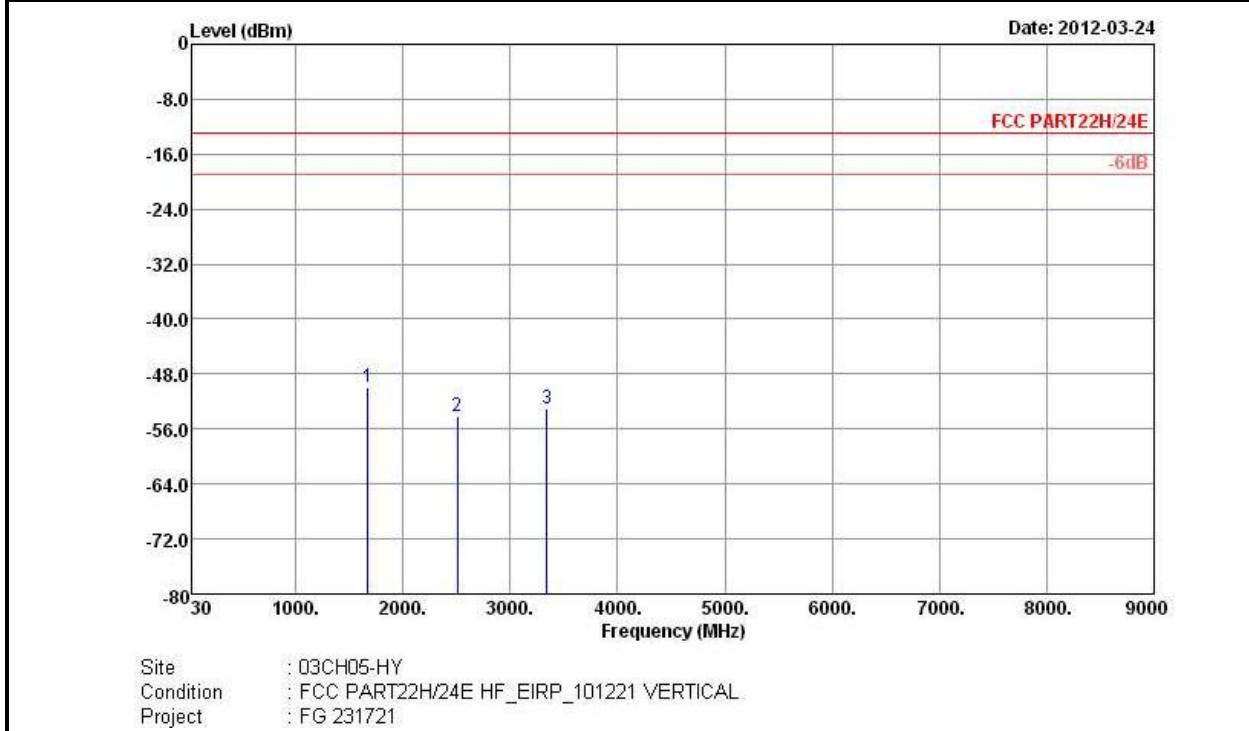

Frequency (MHz)	ERP (dBm)	Limit (dBm)	Over Limit (dB)	SPA Reading (dBm)	S.G. Power (dBm)	TX Cable loss (dB)	TX Antenna Gain (dBi)	Polarization (H/V)	Result
1672	-50.00	-13	-37.00	-55.93	-51.19	2.15	5.49	V	Pass
2509	-54.11	-13	-41.11	-63.5	-56	2.38	6.41	V	Pass
3345	-53.11	-13	-40.11	-64.76	-56.44	2.86	8.34	V	Pass



Band :	GSM850	Temperature :	20~22°C
Test Mode :	EDGE 8 Link	Relative Humidity :	40~42%
Test Engineer :	David Ke	Polarization :	Horizontal
Remark :	Spurious emissions within 30-1000MHz were found more than 20dB below limit line.		

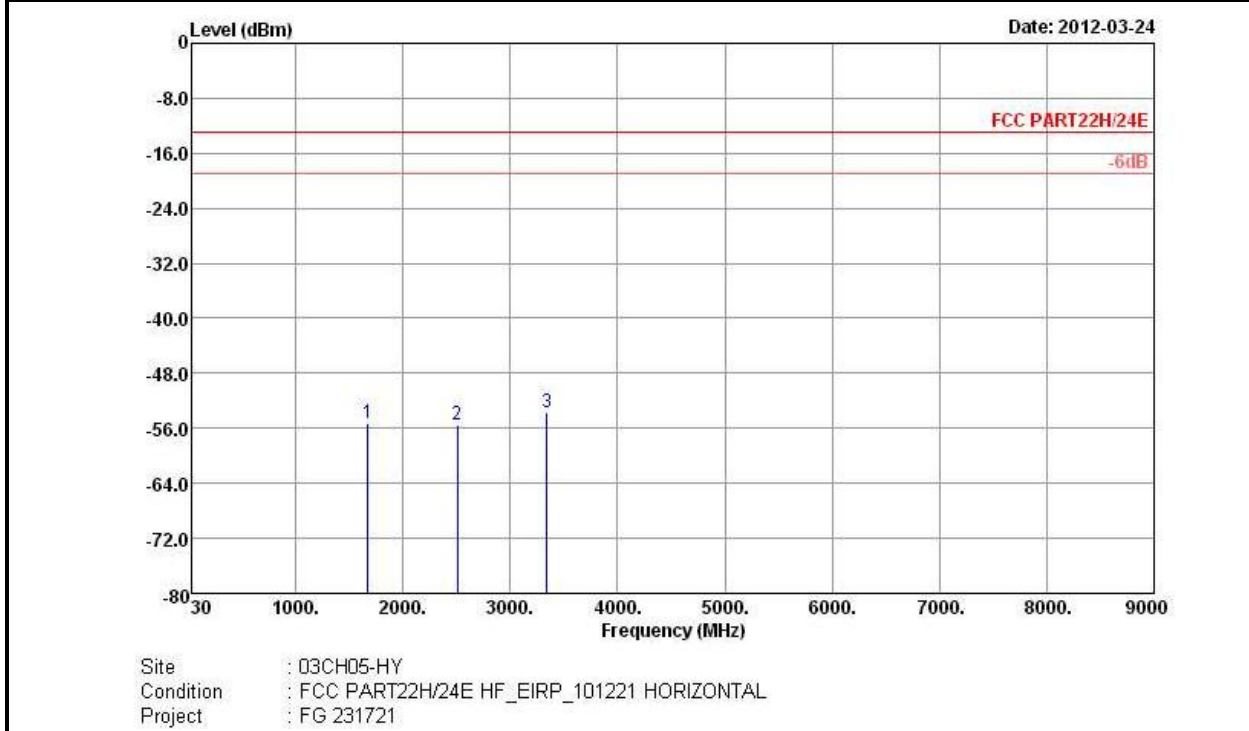

Frequency (MHz)	ERP (dBm)	Limit (dBm)	Over Limit (dB)	SPA Reading (dBm)	S.G. Power (dBm)	TX Cable loss (dB)	TX Antenna Gain (dBi)	Polarization (H/V)	Result
1672	-55.35	-13	-42.35	-61.49	-56.54	2.15	5.49	H	Pass
2509	-55.52	-13	-42.52	-64.97	-57.41	2.38	6.41	H	Pass
3345	-53.67	-13	-40.67	-65.34	-57	2.86	8.34	H	Pass



Band :	GSM850	Temperature :	20~22°C
Test Mode :	EDGE 8 Link	Relative Humidity :	40~42%
Test Engineer :	David Ke	Polarization :	Vertical
Remark :	Spurious emissions within 30-1000MHz were found more than 20dB below limit line.		

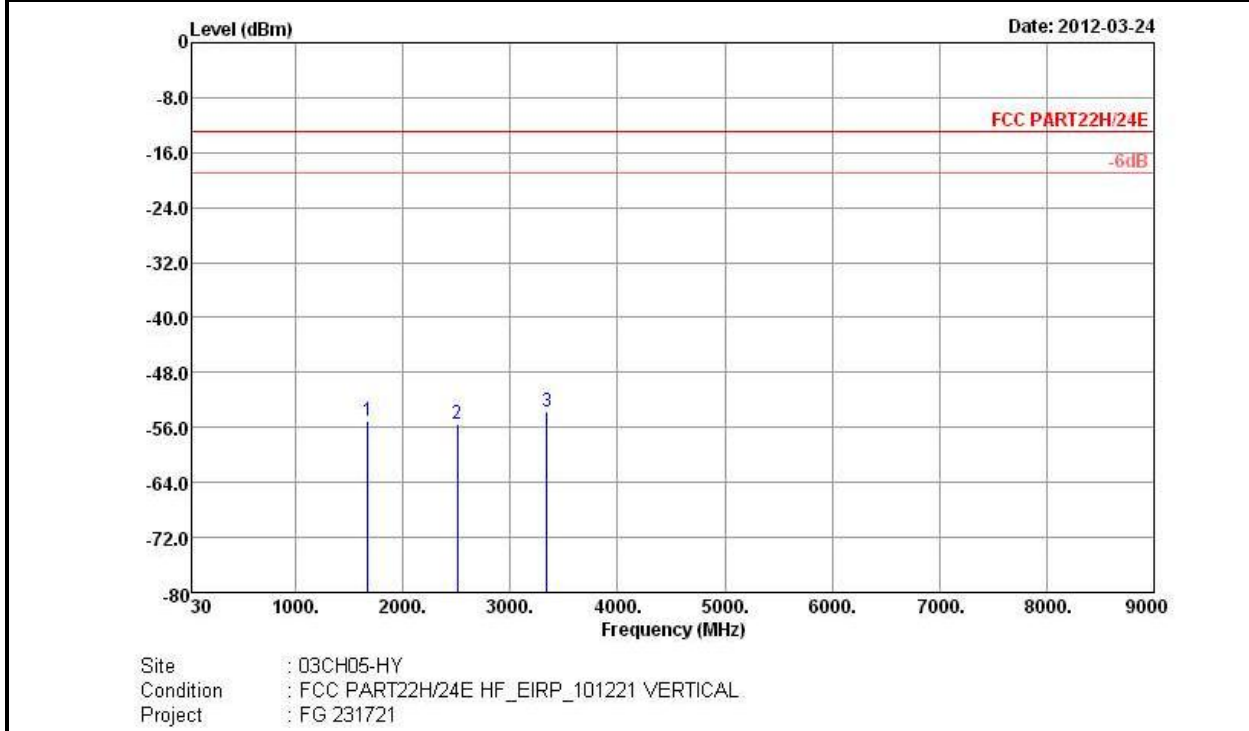

Frequency (MHz)	ERP (dBm)	Limit (dBm)	Over Limit (dB)	SPA Reading (dBm)	S.G. Power (dBm)	TX Cable loss (dB)	TX Antenna Gain (dBi)	Polarization (H/V)	Result
1672	-55.05	-13	-42.05	-61.08	-56.24	2.15	5.49	V	Pass
2509	-55.42	-13	-42.42	-64.75	-57.31	2.38	6.41	V	Pass
3345	-53.67	-13	-40.67	-65.16	-57	2.86	8.34	V	Pass



Band :	GSM1900	Temperature :	20~22°C
Test Mode :	GSM Link	Relative Humidity :	40~42%
Test Engineer :	David Ke	Polarization :	Horizontal
Remark :	Spurious emissions within 30-1000MHz were found more than 20dB below limit line.		

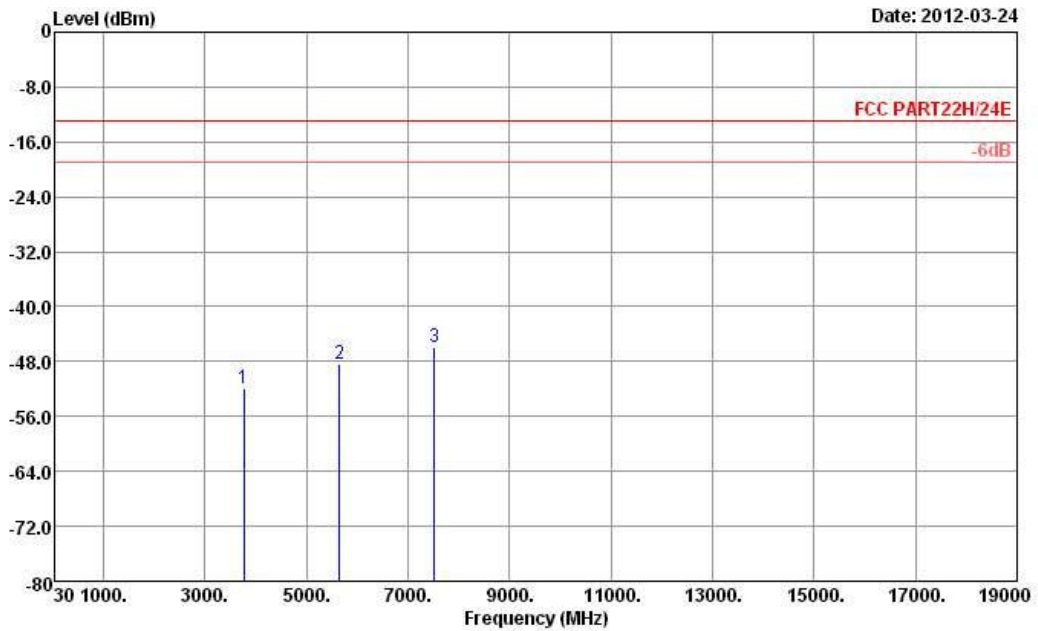

Site : 03CH05-HY
 Condition : FCC PART22H/24E HF_EIRP_101221 HORIZONTAL
 Project : FG 231721

Frequency (MHz)	EIRP (dBm)	Limit (dBm)	Over Limit (dB)	SPA Reading (dBm)	S.G. Power (dBm)	TX Cable loss (dB)	TX Antenna Gain (dBi)	Polarization (H/V)	Result
3760	-51.87	-13	-38.87	-65.32	-58	2.9292	9.06	H	Pass
5640	-48.30	-13	-35.30	-67.32	-55.22	3.9072	10.83	H	Pass
7520	-45.85	-13	-32.85	-67.77	-53.87	4.5988	12.62	H	Pass



Band :	GSM1900	Temperature :	20~22°C
Test Mode :	GSM Link	Relative Humidity :	40~42%
Test Engineer :	David Ke	Polarization :	Vertical
Remark :	Spurious emissions within 30-1000MHz were found more than 20dB below limit line.		

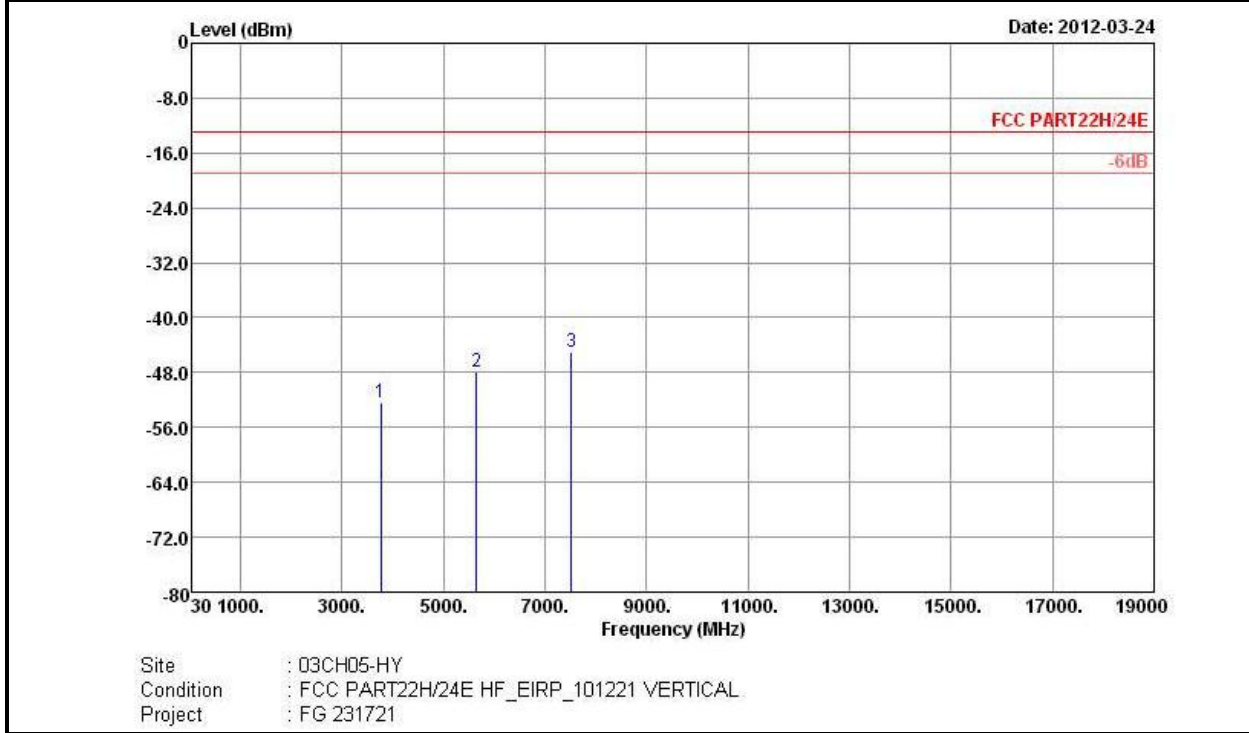

Frequency (MHz)	EIRP (dBm)	Limit (dBm)	Over Limit (dB)	SPA Reading (dBm)	S.G. Power (dBm)	TX Cable loss (dB)	TX Antenna Gain (dBi)	Polarization (H/V)	Result
3760	-52.34	-13	-39.34	-66	-58.47	2.9292	9.06	V	Pass
5640	-48.01	-13	-35.01	-66.82	-54.93	3.9072	10.83	V	Pass
7520	-45.08	-13	-32.08	-67	-53.1	4.5988	12.62	V	Pass



Band :	GSM1900	Temperature :	20~22°C
Test Mode :	EDGE 8 Link	Relative Humidity :	40~42%
Test Engineer :	David Ke	Polarization :	Horizontal
Remark :	Spurious emissions within 30-1000MHz were found more than 20dB below limit line.		

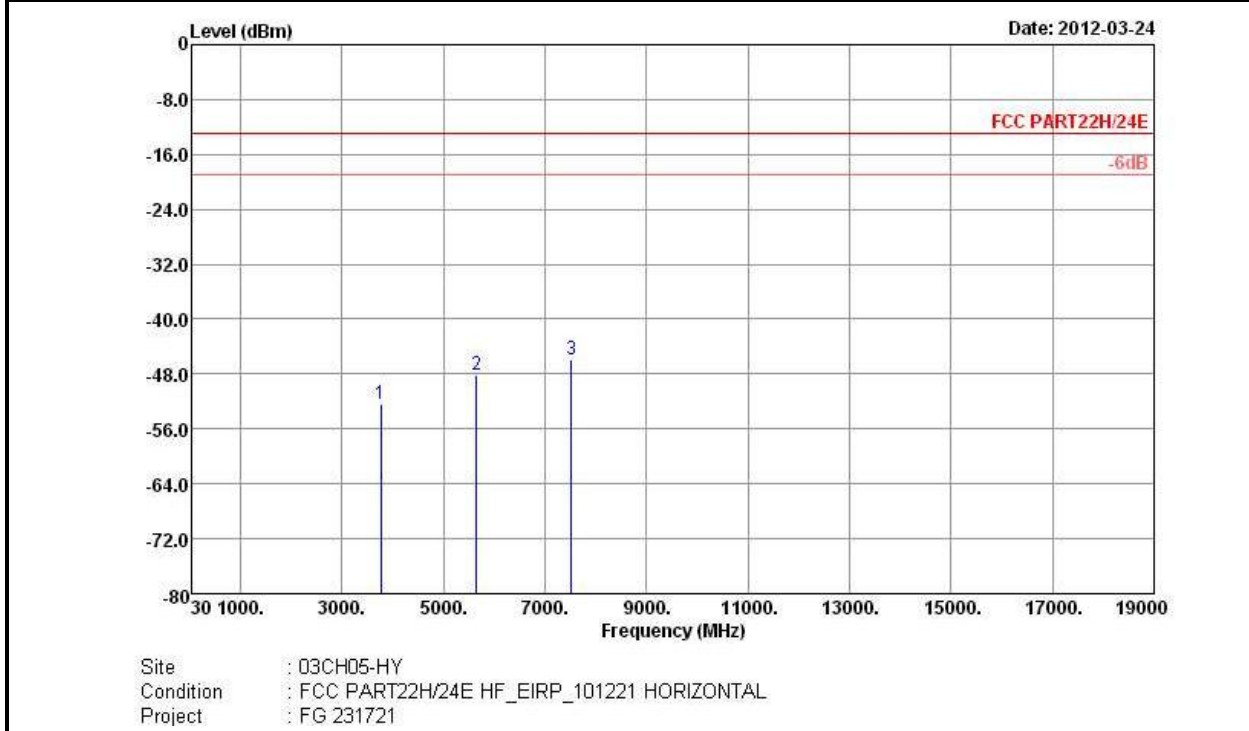

Frequency (MHz)	EIRP (dBm)	Limit (dBm)	Over Limit (dB)	SPA Reading (dBm)	S.G. Power (dBm)	TX Cable loss (dB)	TX Antenna Gain (dBi)	Polarization (H/V)	Result
3760	-52.28	-13	-39.28	-65.68	-58.41	2.9292	9.06	H	Pass
5640	-48.08	-13	-35.08	-67.12	-55	3.9072	10.83	H	Pass
7520	-45.85	-13	-32.85	-67.77	-53.87	4.5988	12.62	H	Pass



Band :	GSM1900	Temperature :	20~22°C
Test Mode :	EDGE 8 Link	Relative Humidity :	40~42%
Test Engineer :	David Ke	Polarization :	Vertical
Remark :	Spurious emissions within 30-1000MHz were found more than 20dB below limit line.		

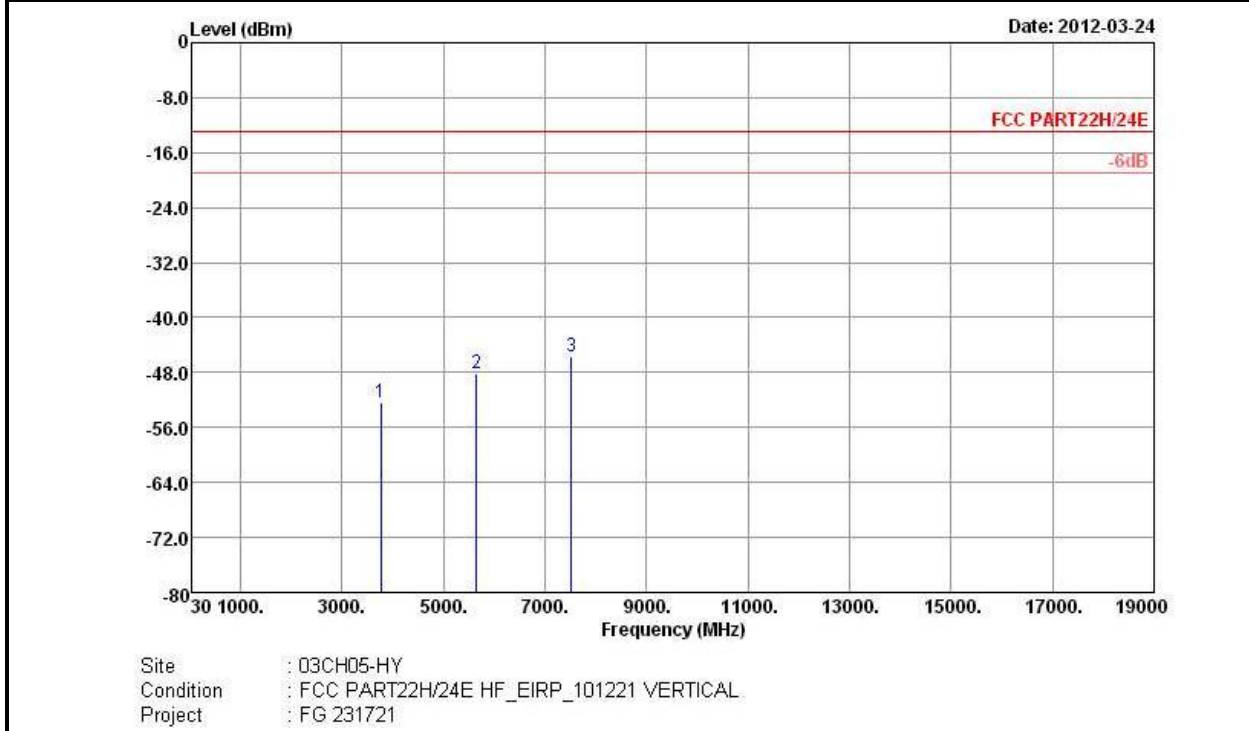

Frequency (MHz)	EIRP (dBm)	Limit (dBm)	Over Limit (dB)	SPA Reading (dBm)	S.G. Power (dBm)	TX Cable loss (dB)	TX Antenna Gain (dBi)	Polarization (H/V)	Result
3760	-52.32	-13	-39.32	-65.8	-58.45	2.9292	9.06	V	Pass
5640	-48.08	-13	-35.08	-67.18	-55	3.9072	10.83	V	Pass
7520	-45.72	-13	-32.72	-67.71	-53.74	4.5988	12.62	V	Pass

3.7 Frequency Stability Measurement

3.7.1 Description of Frequency Stability Measurement

The frequency stability shall be measured by variation of ambient temperature and variation of primary supply voltage to ensure that the fundamental emission stays within the authorized frequency block. The frequency stability of the transmitter shall be maintained within $\pm 0.00025\%$ ($\pm 2.5\text{ppm}$) of the center frequency.

3.7.2 Measuring Instruments

See list of measuring instruments of this test report.

3.7.3 Test Procedures for Temperature Variation

1. The EUT was set up in the thermal chamber and connected with the base station.
2. With power OFF, the temperature was decreased to -30°C and the EUT was stabilized for three hours. Power was applied and the maximum change in frequency was recorded within one minute.
3. With power OFF, the temperature was raised in 10°C step up to 50°C . The EUT was stabilized at each step for at least half an hour. Power was applied and the maximum frequency change was recorded within one minute.
4. If the EUT cannot be turned on at -30°C , the testing lowest temperature will be raised in 10°C step until the EUT can be turned on.

3.7.4 Test Procedures for Voltage Variation

1. The EUT was placed in a temperature chamber at $25\pm 5^{\circ}\text{C}$ and connected with the base station.
2. The power supply voltage to the EUT was varied from BEP to 115% of the nominal value measured at the input to the EUT.
3. The variation in frequency was measured for the worst case.

3.7.5 Test Setup

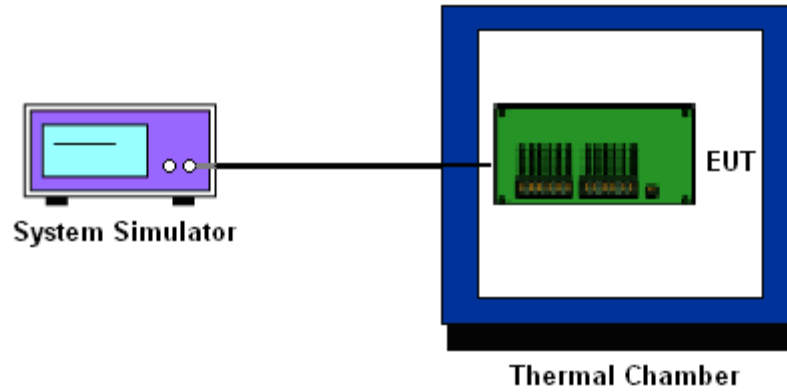

3.7.6 Test Result of Temperature Variation

Band :	GSM 850		Channel :	189	
Limit (ppm) :	2.5				
Temperature (°C)	GSM		EDGE 8		Result
	Freq. Dev. (Hz)	Deviation (ppm)	Freq. Dev. (Hz)	Deviation (ppm)	
-30	N/A	N/A	N/A	N/A	PASS
-20	26	0.03	16	0.02	
-10	29	0.03	15	0.02	
0	31	0.04	18	0.02	
10	39	0.05	20	0.02	
20	31	0.04	13	0.02	
30	51	0.06	18	0.02	
40	44	0.05	19	0.02	
50	33	0.04	14	0.02	



Band :	GSM 1900	Channel :	661
Limit (ppm) :	2.5		

Temperature (°C)	GSM		EDGE 8		Result
	Freq. Dev. (Hz)	Deviation (ppm)	Freq. Dev. (Hz)	Deviation (ppm)	
-30	N/A	N/A	N/A	N/A	PASS
-20	67	0.04	43	0.02	
-10	52	0.03	26	0.01	
0	48	0.03	15	0.01	
10	43	0.02	20	0.01	
20	29	0.02	11	0.01	
30	46	0.02	22	0.01	
40	44	0.02	23	0.01	
50	40	0.02	18	0.01	

3.7.7 Test Result of Voltage Variation

Band & Channel	Mode	Voltage (Volt)	Freq. Dev. (Hz)	Deviation (ppm)	Limit (ppm)	Result
GSM 850 CH189	GSM	3.8	37	0.04	2.5	PASS
		BEP	34	0.04		
		4.2	39	0.05		
	EDGE 8	3.8	26	0.03		
		BEP	22	0.03		
		4.2	30	0.04		
GSM 1900 CH661	GSM	3.8	34	0.02		
		BEP	29	0.02		
		4.2	26	0.01		
	EDGE 8	3.8	21	0.01		
		BEP	18	0.01		
		4.2	14	0.01		

Note:

1. Normal Voltage = 3.8V.
2. Battery End Point (BEP) = 3.5 V.





4 List of Measuring Equipment

Instrument	Manufacturer	Model No.	Serial No.	Characteristics	Calibration Date	Test Date	Due Date	Remark
System Simulator	R&S	CMU200	117995	N/A	Jul. 28, 2011	Mar. 22, 2012~ Mar. 23, 2012~	Jul. 27, 2012	Conducted (TH02-HY)
Spectrum Analyzer	R&S	FSP40	100055	9kHz~40GHz	Jun. 13, 2011	Mar. 22, 2012~ Mar. 23, 2012~	Jun. 12, 2012	Conducted (TH02-HY)
Thermal Chamber	Ten Billion	TTH-D35P	TBN-930701	N/A	Jul. 27, 2011	Mar. 22, 2012~ Mar. 23, 2012~	Jul. 26, 2012	Conducted (TH02-HY)
Spectrum Analyzer	R&S	ESU26	100390	20Hz ~ 26.5GHz	Dec. 22, 2011	Mar. 24, 2012	Dec. 21, 2012	Radiation (03CH05-HY)
COM-POWER	Double Ridge Horn	AH-118	701030	1GHz ~ 18GHz	N/A	Mar. 24, 2012	N/A	Radiation (03CH05-HY)
Bilog Antenna	SCHAFFNER	CBL6111C	2725	30MHz ~ 2GHz	Oct. 22, 2011	Mar. 24, 2012	Oct. 21, 2012	Radiation (03CH05-HY)
Turn Table	HD	Deis HD 2000	420/611	0 ~ 360 degree	N/A	Mar. 24, 2012	N/A	Radiation (03CH05-HY)
Antenna Mast	HD	MA 240	240/666	1 m ~ 4 m	N/A	Mar. 24, 2012	N/A	Radiation (03CH05-HY)
Horn Antenna	ESCO	3117	66584	1GHz ~ 18GHz	Aug. 04, 2011	Mar. 24, 2012	Aug. 03, 2012	Radiation (03CH05-HY)
COM-POWER	COM-POWER	PA-103	161075	10Hz ~ 1000MHz Gain:32dB	Mar. 29, 2011	Mar. 24, 2012	Mar. 28, 2012	Radiation (03CH05-HY)
Pre Amplifier	EMCI	EMC051845	SN980048	1GHz~18GHz	Jul. 18, 2011	Mar. 24, 2012	Jul. 17, 2012	Radiation (03CH05-HY)
Pre Amplifier	Agilent	8449B	3008A01917	1GHz~26.5GHz	Aug. 30, 2011	Mar. 24, 2012	Aug. 29, 2012	Radiation (03CH05-HY)
Loop Antenna	R&S	HFH2-Z2	860004/001	9 kHz~30 MHz	Jul. 29, 2010	Mar. 24, 2012	Jul. 28, 2012	Radiation (03CH05-HY)
System Simulator	R&S	CMU200	117591	N/A	Oct. 21, 2011	Mar. 24, 2012	Oct. 20, 2012	Radiation (03CH05-HY)



5 Uncertainty of Evaluation

Uncertainty of Radiated Emission Measurement (30 MHz ~ 1000 MHz)

Contribution	Uncertainty of X_i		$u(X_i)$
	dB	Probability Distribution	
Receiver Reading	0.41	Normal (k=2)	0.21
Antenna Factor Calibration	0.83	Normal (k=2)	0.42
Cable Loss Calibration	0.25	Normal (k=2)	0.13
Pre-Amplifier Gain Calibration	0.27	Normal (k=2)	0.14
RCV/SPA Specification	2.50	Rectangular	0.72
Antenna Factor Interpolation for Frequency	1.00	Rectangular	0.29
Site Imperfection	1.43	Rectangular	0.83
Mismatch	+0.39 / -0.41	U-Shape	0.28
Combined Standard Uncertainty $U_c(y)$	1.27		
Measuring Uncertainty for a Level of Confidence of 95% ($U = 2U_c(y)$)	2.54		

Uncertainty of Radiated Emission Measurement (1 GHz ~ 40 GHz)

Contribution	Uncertainty of X_i		$u(X_i)$	C_i	$C_i * u(X_i)$
	dB	Probability Distribution			
Receiver Reading	± 0.10	Normal (k=2)	0.10	1	0.10
Antenna Factor Calibration	± 1.70	Normal (k=2)	0.85	1	0.85
Cable Loss Calibration	± 0.50	Normal (k=2)	0.25	1	0.25
Receiver Correction	± 2.00	Rectangular	1.15	1	1.15
Antenna Factor Directional	± 1.50	Rectangular	0.87	1	0.87
Site Imperfection	± 2.80	Triangular	1.14	1	1.14
Mismatch Receiver VSWR $\Gamma_1 = 0.197$ Antenna VSWR $\Gamma_2 = 0.194$ Uncertainty = $20\text{Log}(1-\Gamma_1*\Gamma_2)$	+0.34 / -0.35	U-Shape	0.244	1	0.244
Combined Standard Uncertainty $U_c(y)$	2.36				
Measuring Uncertainty for a Level of Confidence of 95% ($U = 2U_c(y)$)	4.72				



Appendix A. Photographs of EUT

Please refer to Sporton report number EP231721 as below.



1. External Photograph of EUT

Brand Name: Universal Global Scientific Industrial Co., Ltd.

Model Name / Marketing Name: UNA_900

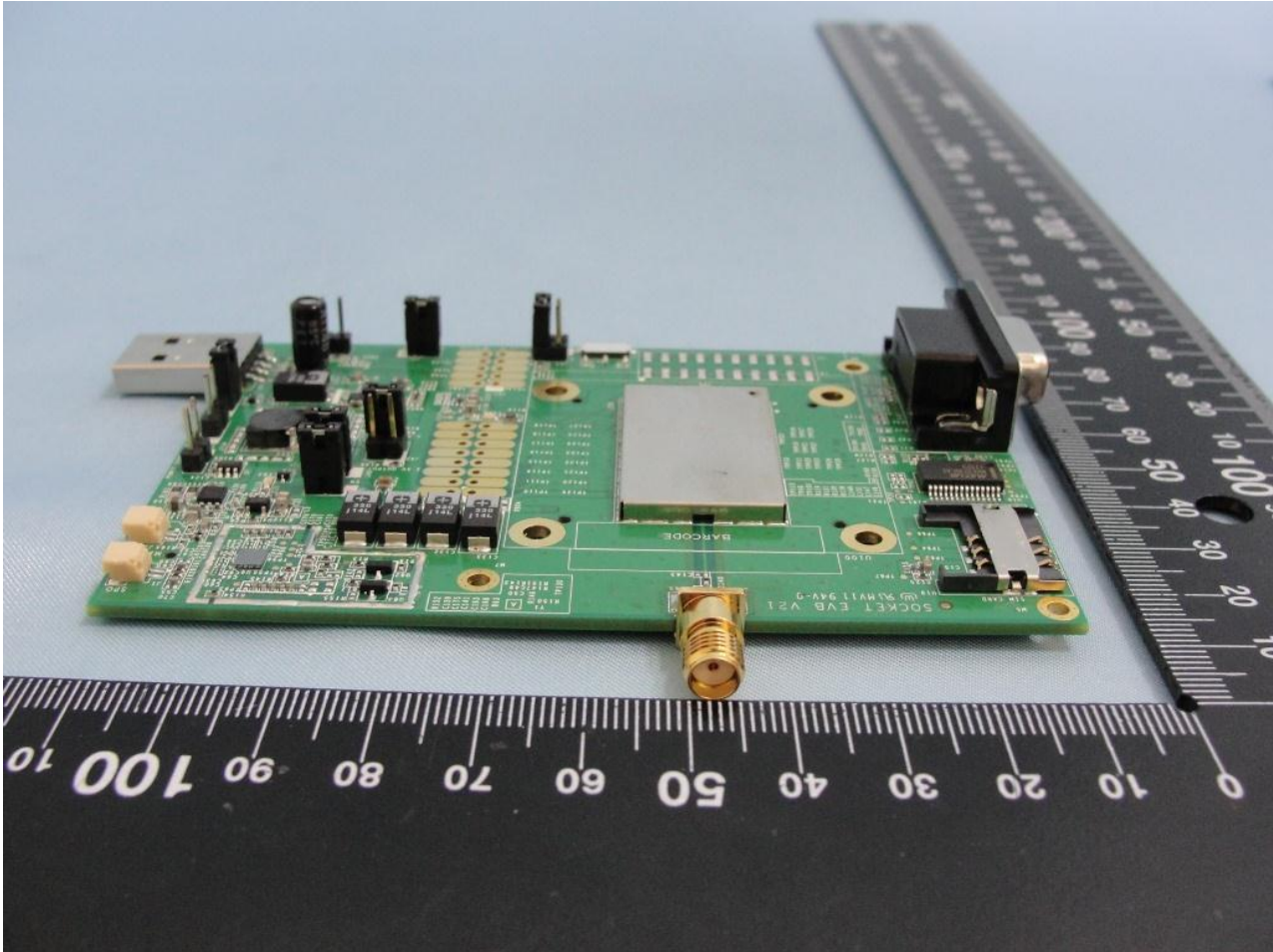

Brand Name: Universal Global Scientific Industrial Co., Ltd.

Model Name / Marketing Name: UNA_900

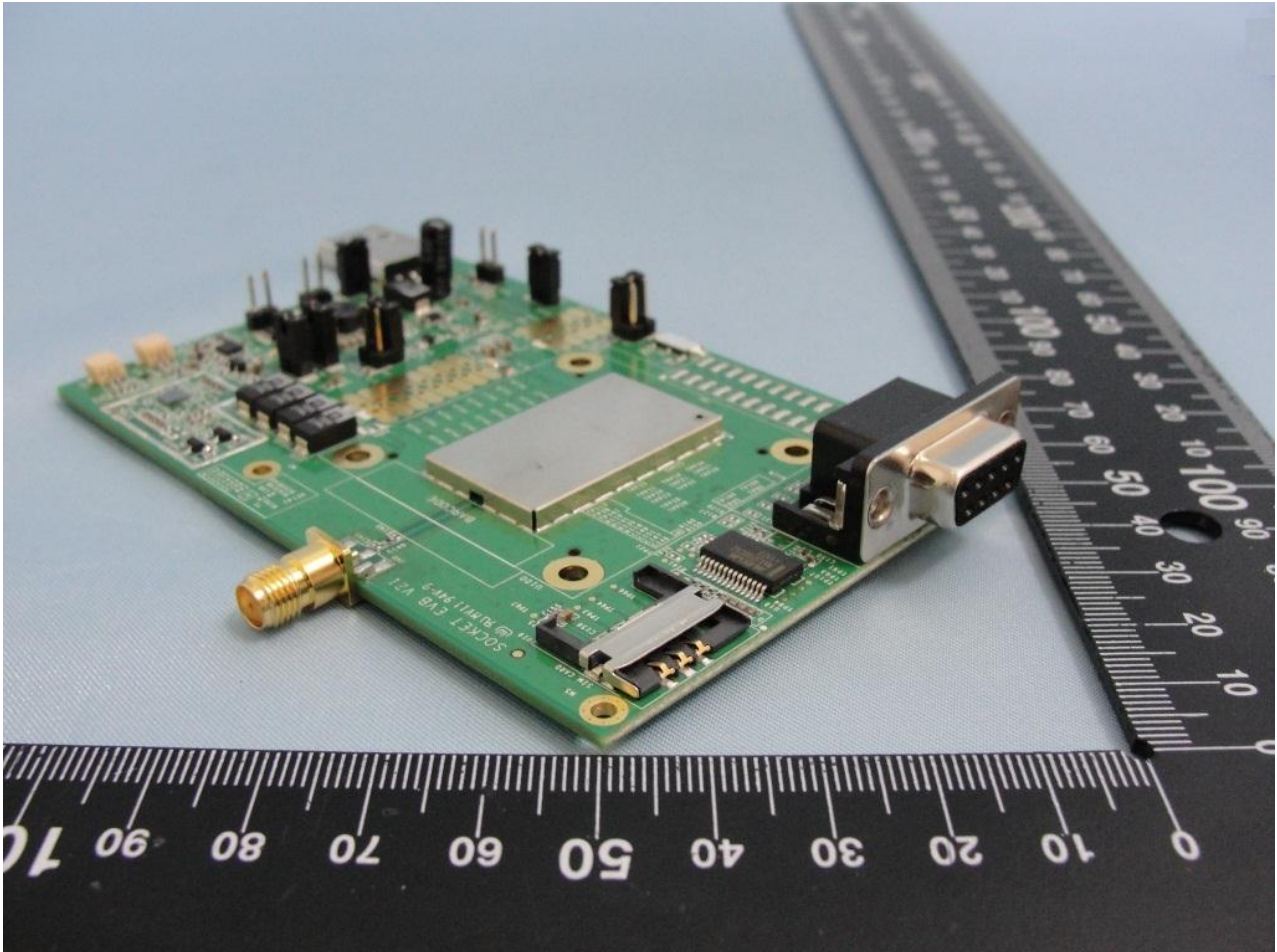

Brand Name: Universal Global Scientific Industrial Co., Ltd.

Model Name / Marketing Name: UNA_900

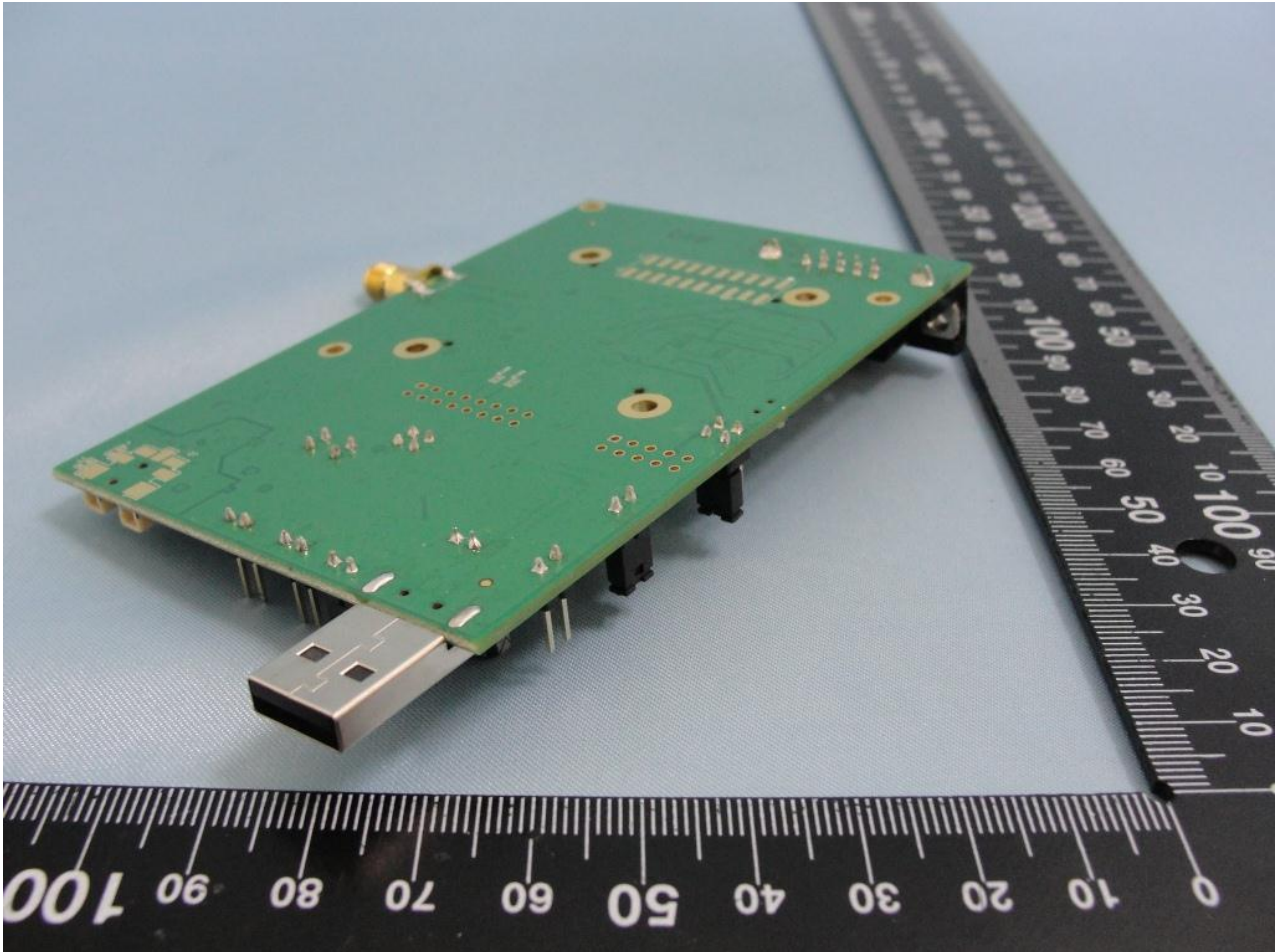



2. Photograph of Accessory

Brand Name: Universal Global Scientific Industrial Co., Ltd.

Model Name / Marketing Name: UNA_900

List of Accessory:

Specification of Accessory		
USB Cable	Brand Name	Universal Global Scientific Industrial Co., Ltd.
	Model Name	UNA

Remark: For accessories equipped with this EUT, please refer to the following photos.

Brand Name: Universal Global Scientific Industrial Co., Ltd.

Model Name / Marketing Name: UNA_900



3. Internal Photograph of EUT

Brand Name: Universal Global Scientific Industrial Co., Ltd.

Model Name / Marketing Name: UNA_900

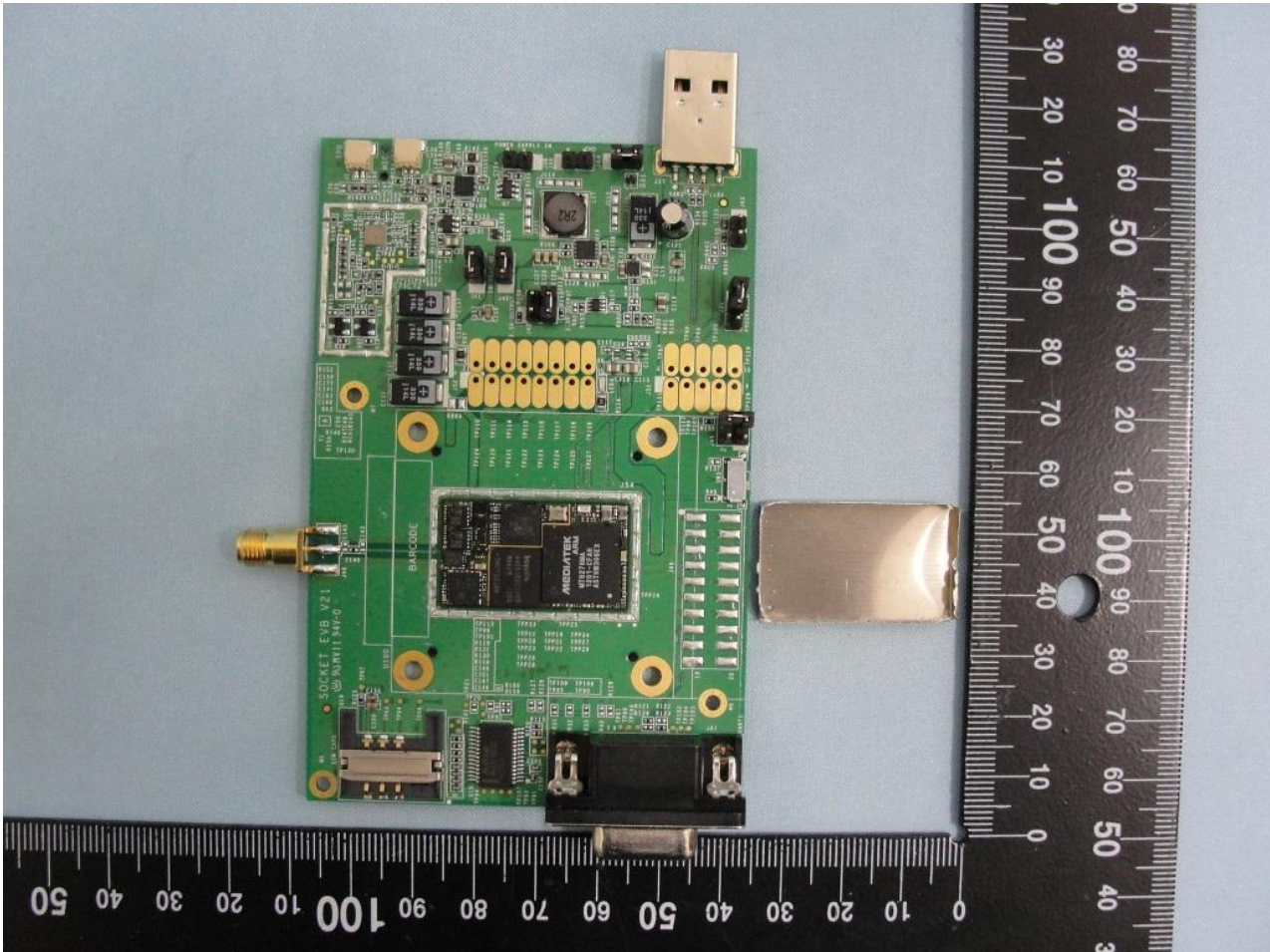

Brand Name: Universal Global Scientific Industrial Co., Ltd.

Model Name / Marketing Name: UNA_900





Brand Name: Universal Global Scientific Industrial Co., Ltd.

Model Name / Marketing Name: UNA_900





Brand Name: Universal Global Scientific Industrial Co., Ltd.

Model Name / Marketing Name: UNA_900

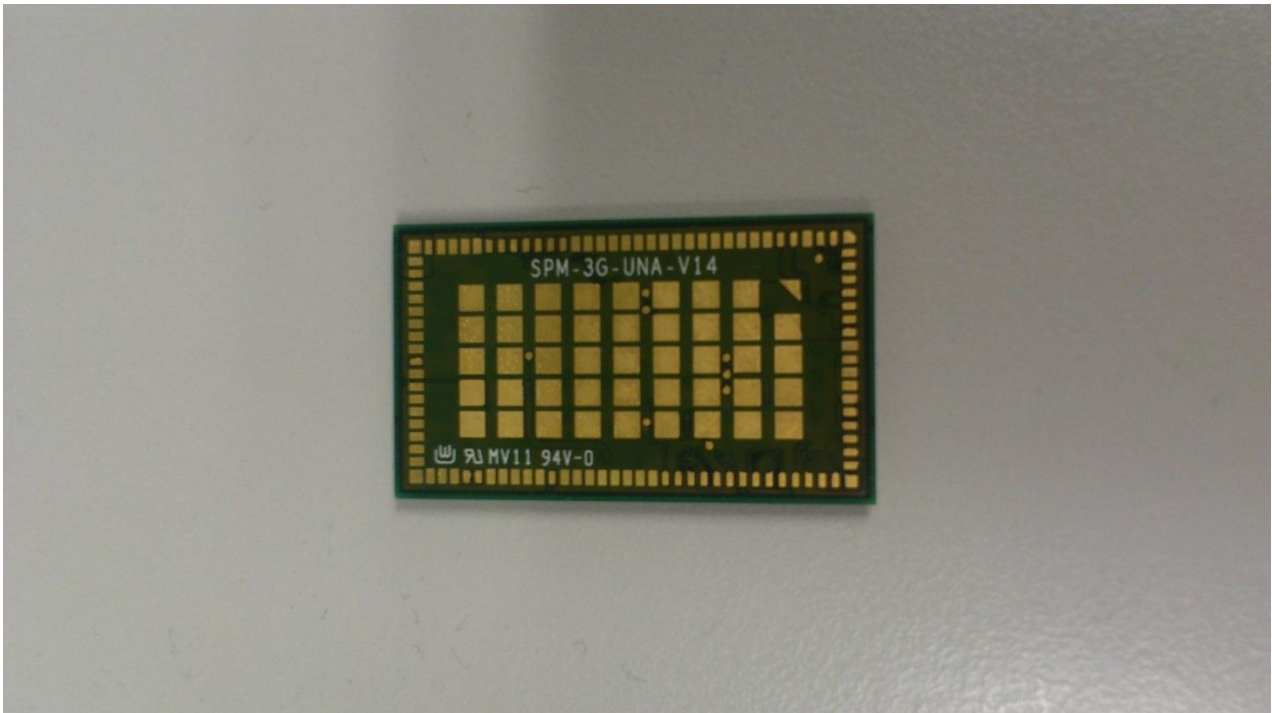



Brand Name: Universal Global Scientific Industrial Co., Ltd.

Model Name / Marketing Name: UNA_900

WWAN Antenna <TX / RX>





Brand Name: Universal Global Scientific Industrial Co., Ltd.

Model Name / Marketing Name: UNA_900

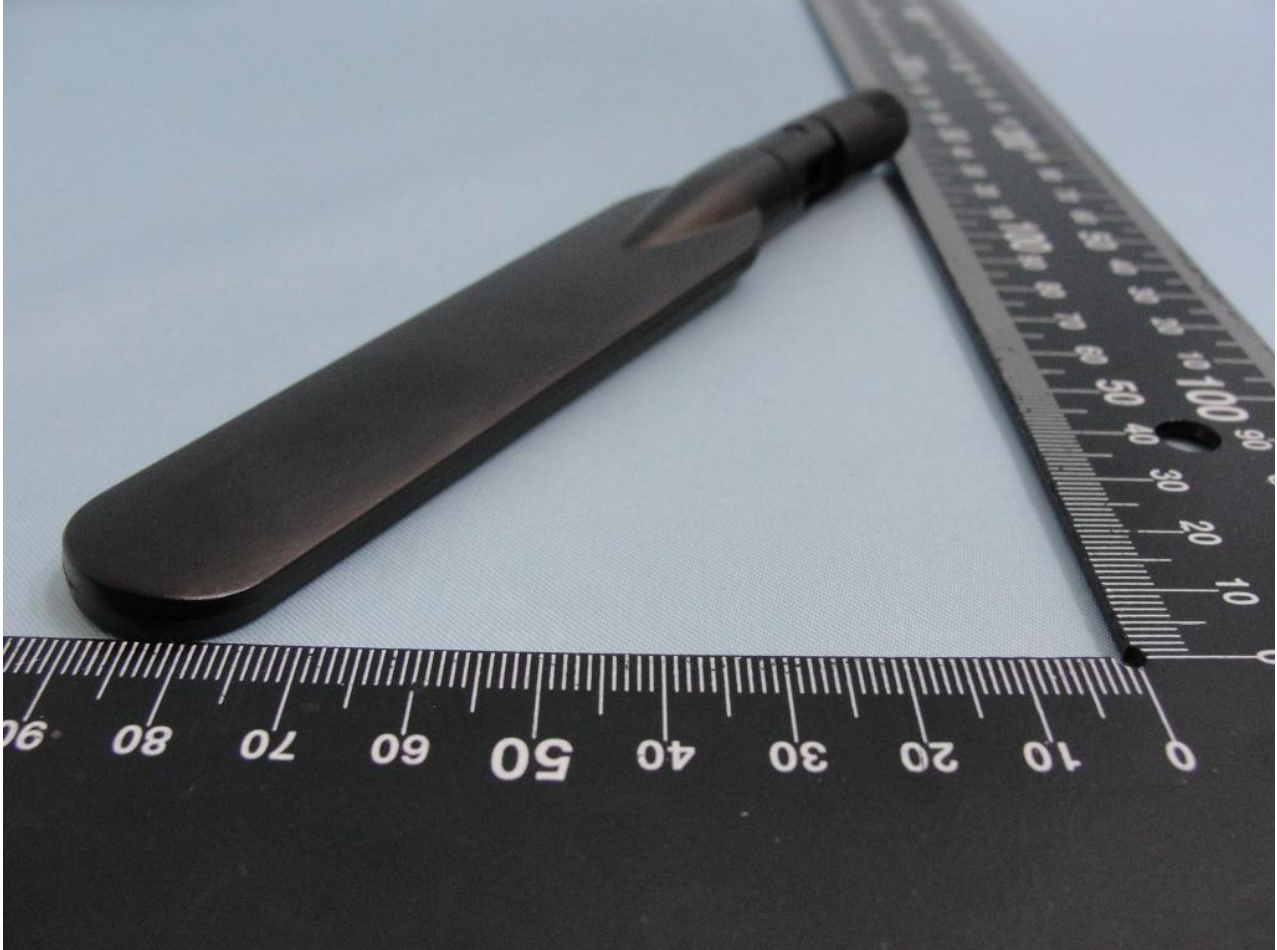

Appendix B. Setup Photographs

<Radiated Emission>

LF

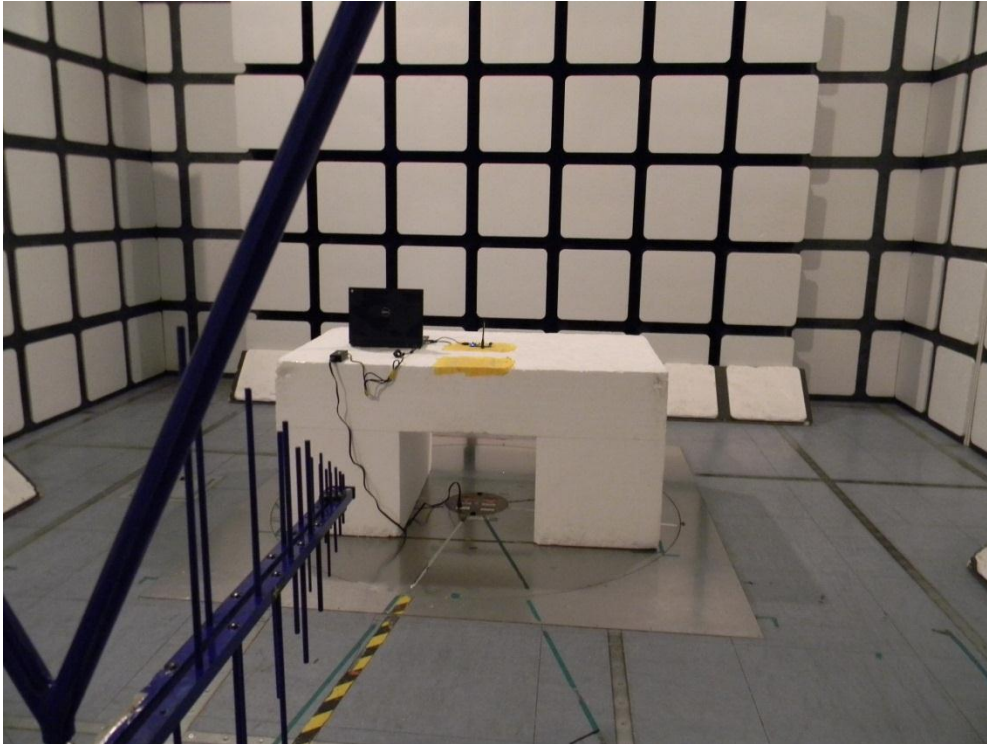

HF

