

# Test Report

Report Number: F122887E3

Applicant:

**deister electronic GmbH**

Manufacturer:

**deister electronic GmbH**

Equipment under Test (EUT):

**TSU200**

Laboratory (CAB) accredited by  
Deutsche Gesellschaft für Akkreditierung mbH  
in compliance with DIN EN ISO/IEC 17025  
under the Reg. No. DGA-PL-105/99-22,  
FCC Test site registration number 90877 and  
Industry Canada Test site registration IC3469A-1

## REFERENCES

- [1] **ANSI C63.4-2009** American National Standard for Methods of Measuring of Radio-Noise Emissions from Low-Voltage Electrical and Electronic Equipment in the Range of 9 kHz to 40 GHz.
- [2] **FCC CFR 47 Part 15 (January 2013)** Radio Frequency Devices
- [3] **FCC Public Notice DA 00-705 (March 2000)**
- [4] **RSS-210 Issue 8 (December 2010)** Licence-exempt Radio Apparatus (All Frequency Bands): Category I Equipment
- [5] **RSS-Gen Issue 3 (December 2010)** General Requirements and Information for the Certification of Radio Apparatus

## TEST RESULT

The requirements of the tests performed as shown in the overview (clause 3) were fulfilled by the equipment under test.  
The complete test results are presented in the following.

Test engineer:	Thomas KÜHN		25 February 2013
	<hr style="border: 0; border-top: 1px solid black;"/>	<hr style="border: 0; border-top: 1px solid black;"/>	<hr style="border: 0; border-top: 1px solid black;"/>
	Name	Signature	Date
Authorized reviewer:	Bernd STEINER		25 February 2013
	<hr style="border: 0; border-top: 1px solid black;"/>	<hr style="border: 0; border-top: 1px solid black;"/>	<hr style="border: 0; border-top: 1px solid black;"/>
	Name	Signature	Date

## RESERVATION

This test report is only valid in its original form.

Any reproduction of its contents in extracts without written permission of the accredited test laboratory PHOENIX TESTLAB GmbH is prohibited.

The test results herein refer only to the tested sample. PHOENIX TESTLAB GmbH is not responsible for any generalisations or conclusions drawn from these test results concerning further samples. Any modification of the tested samples is prohibited and leads to the invalidity of this test report. Each page necessarily contains the PHOENIX TESTLAB Logo and the TEST REPORT NUMBER.

<b>Contents:</b>	<b>Page</b>
1 IDENTIFICATION.....	4
1.1 Applicant .....	4
1.2 Manufacturer .....	4
1.3 Test laboratory .....	4
2 EUT (Equipment Under Test).....	5
2.1 Technical data of equipment.....	5
2.2 Operational states .....	6
3 OVERVIEW .....	7
4 TEST RESULTS.....	8
4.1 20 dB bandwidth .....	8
4.1.1 Method of measurement (20 dB bandwidth) .....	8
4.1.2 Test results (20 dB bandwidth) .....	9
4.2 Carrier frequency separation .....	11
4.2.1 Method of measurement (carrier frequency separation) .....	11
4.2.2 Test results (carrier frequency separation) .....	12
4.3 Number of hopping frequencies.....	14
4.3.1 Method of measurement (number of hopping frequencies) .....	14
4.3.2 Test results (number of hopping frequencies) .....	15
4.4 Dwell time.....	16
4.4.1 Method of measurement (dwell time) .....	16
4.4.2 Test results (dwell time).....	17
4.5 Maximum peak output power.....	18
4.5.1 Method of measurement (maximum peak output power) .....	18
4.5.2 Test results (maximum peak output power) .....	19
4.6 Radiated emissions.....	21
4.6.1 Method of measurement (radiated emissions) .....	21
4.6.2 Test results (radiated emissions).....	26
4.6.2.1 Preliminary radiated emission measurement .....	26
4.6.2.2 Final radiated emission measurement (30 MHz to 1 GHz) with internal antenna .....	38
4.6.2.3 Final radiated emission measurement (1 GHz to 40 GHz) with internal antenna .....	42
4.7 Conducted emissions on power supply lines (150 kHz to 30 MHz).....	45
4.7.1 Method of measurement.....	45
4.7.2 Test results (conducted emissions on power supply lines) .....	46
5 TEST EQUIPMENT AND ANCILLARIES USED FOR TESTS .....	48
6 REPORT HISTORY .....	49
7 LIST OF ANNEXES.....	49

# 1 IDENTIFICATION

## 1.1 Applicant

Name:	deister electronic GmbH
Address:	Hermann-Balsen-Straße 11 – 13 30890 Barsinghausen
Country:	Germany
Name for contact purposes:	Mr. Thimo Eichstädt
Phone:	+49 51 05 516 - 272
Fax:	+49 51 05 516 - 217
eMail Address:	thimo.eichstaedt@deister.com
Applicant represented during the test by the following person:	-

## 1.2 Manufacturer

Name:	deister electronic GmbH
Address:	Hermann-Balsen-Straße 11 – 13 30890 Barsinghausen
Country:	Germany
Name for contact purposes:	Mr. Thimo Eichstädt
Phone:	+49 51 05 516 - 272
Fax:	+49 51 05 516 - 217
eMail Address:	thimo.eichstaedt@deister.com
Manufacturer represented during the test by the following person:	-

## 1.3 Test laboratory

The tests were carried out at: **PHOENIX TESTLAB GmbH**  
**Königswinkel 10**  
**32825 Blomberg**  
**Germany**

accredited by DGA Deutsche Gesellschaft für Akkreditierung mbH in compliance with DIN EN ISO/IEC 17025 under Reg. No. DGA-PL-105/99-22, FCC Test site registration number 90877 and Industry Canada Test site registration IC3469A-1.

## 2 EUT (Equipment Under Test)

Test object: *	UHF RFID read/write device
Model name: *	TSU200
FCC ID: *	IXLTSU200
IC: *	1893B-TSU200
PCB identifier: *	121104 Rev. 265 (main PCB), 3639/0 (coupler), 3638/0 (antenna)
Serial number: *	7189400402
Hardware version: *	1.02
Software version: *	1.40
Lowest / highest internal frequency: *	16 MHz / 4 times the channel frequency

### 2.1 Technical data of equipment

Channel 0	RX:	902.75 MHz	TX:	902.75 MHz
Channel 24	RX:	914.75 MHz	TX:	914.75 MHz
Channel 49	RX:	927.25 MHz	TX:	927.25 MHz

Rated RF output power: *	30 dBm (conducted)				
Antenna type: *	Internal				
Antenna gain: *	3.15 dBi				
Adaptive frequency agility: *	Yes				
Modulation: *	FHSS (PR-ASK / DSB-ASK)				
Supply Voltage: *	U <sub>nom</sub> =	12.0 V DC	U <sub>min</sub> =	10.0 V DC	U <sub>max</sub> = 28.0 V DC
Temperature range: *	-20 °C to +50 °C				
Ancillary used for test:	An USB/RS485 converter type SNG 3 was used to connect the EUT to the power supply and the laptop computer. During the conducted emission measurement on the AC-supply line a AC / DC adaptor type FW3288 was used.				

\* declared by the applicant.

The following external I/O cables were used:

Identification	Connector		Length
	EUT	Ancillary	
Power / RS485	5 pin M12-connector	4 pole Combicon-connector	2.5 m
-	-	-	-

\*: Length during the test if no other specified.

## 2.2 Operational states

All tests were carried out with an unmodified sample with integral antenna.

During all tests the TSU200 was powered by an external power supply with 12.0 V DC.

The operation mode could be chosen with the help of a laptop computer with a test-software, which communicates with the EUT via the RS485 line. The RS485 connection between the laptop PC and the EUT (via the USB/RS485 converter) was maintained during all tests.

The conducted measurements were carried out at the internal antenna connector of the EUT.

For all measurements the output power of the EUT was set to 30 dBm (maximum value).

The tested sample was not labelled with a label, which fulfils the FCC /IC requirements.

The following operation modes were used during the tests:

Operation mode	Description of the operation mode
1	Transmit on 902.750 MHz (channel 0)
2	Transmit on 914.750 MHz (channel 24)
3	Transmit on 927.250 MHz (channel 49)
4	Transmit on all channels (hopping enabled)

Physical boundary of the EUT

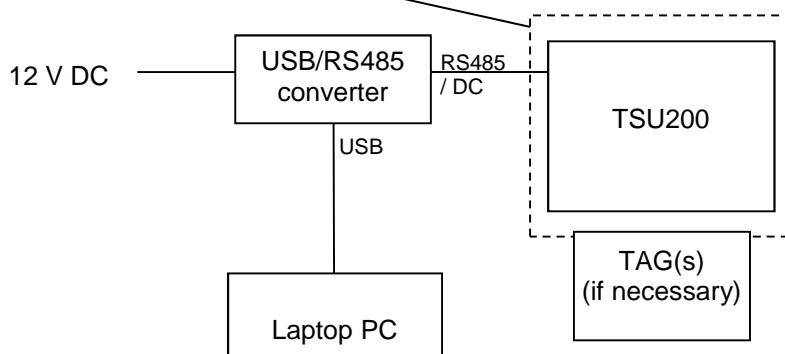

### 3 OVERVIEW

Application	Frequency range [MHz]	FCC 47 CFR Part 15 section [2]	RSS 210, Issue 8 [4] or RSS-Gen, Issue 3 [5]	Status	Refer page
20 dB bandwidth	General	15.247 (a) (1) (i)	A8.1 (c) [4]	Passed	8 et seq.
Carrier frequency separation	General	15.247 (a) (1) (i)	-	Passed	11 et seq.
Number of hopping channels	902.0 – 928.0	15.247 (a) (1) (i)	A8.1 (c) [4]	Passed	14 et seq.
Dwell time	902.0 – 928.0	15.247 (a) (1) (i)	A8.1 (c) [4]	Passed	16 et seq.
Maximum peak output power	902.0 – 928.0	15.247 (b) (2)	A8.4 (1) [4]	Passed	18 et seq.
Radiated emissions (transmitter)	0.009 - 10,000	15.247 (d) 15.205 (a) 15.209 (a)	A8.5 [4] 2.5 [4] 7.2.2 [5]	Passed	21 et seq.
Conducted emissions on supply line	0.15 - 30	15.207 (a)	7.2.4 [5]	Passed	45 et seq.

## 4 TEST RESULTS

### 4.1 20 dB bandwidth

#### 4.1.1 Method of measurement (20 dB bandwidth)

The calibration of the spectrum analyser has to be checked with the help of a known signal from a signal generator. The EUT has to be connected to the spectrum analyser via a low loss cable. If the EUT is not equipped with an antenna connector, a temporary antenna connector has to be installed. The EUT has to be switched on and the hopping function has to be disabled, the transmitter shall work with its maximum data rate.

The following spectrum analyser settings shall be used:

- Span: App. 2 to 3 times the 20 dB bandwidth, centred on the actual hopping channel.
- Resolution bandwidth:  $\geq 1\%$  of the 20 dB bandwidth.
- Video bandwidth:  $\geq$  the resolution bandwidth.
- Sweep: Auto.
- Detector function: peak.
- Trace mode: Max hold.

After trace stabilisation the marker shall be set on the signal peak. The first display line has to be set on this value. The second display line has to be set 20 dB below the first line (or the peak marker). The frequency lines shall be set on the intersection points between the second display line and the measured curve.

The measurement will be performed at the upper, the lower end and the middle of the assigned frequency band.

Test set-up:

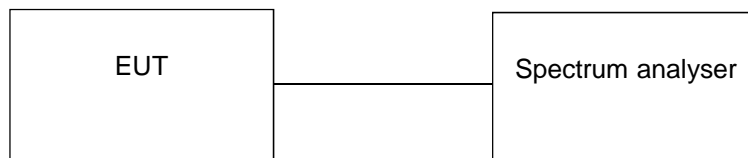



#### 4.1.2 Test results (20 dB bandwidth)

Ambient temperature	21 °C	Relative humidity	20 %
---------------------	-------	-------------------	------

122887\_64.wmf: 20 dB bandwidth at the lower end of the assigned frequency band:

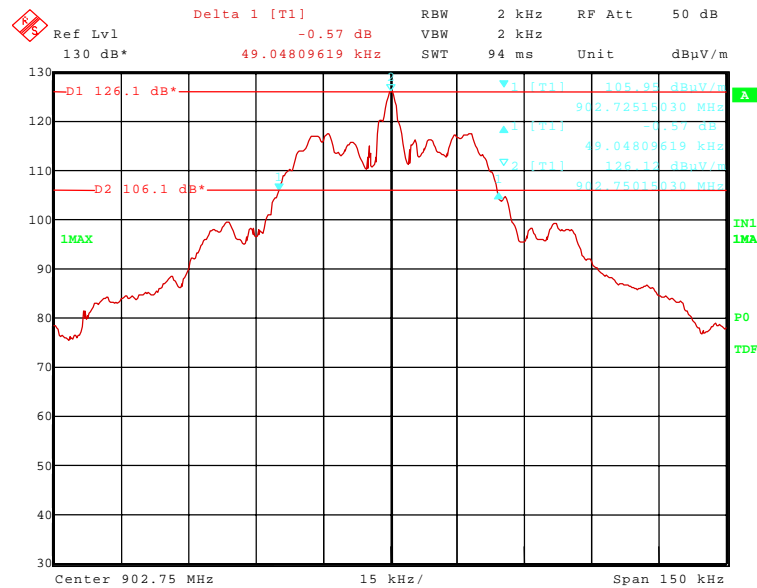

122887\_65.wmf: 20 dB bandwidth at the middle of the assigned frequency band:

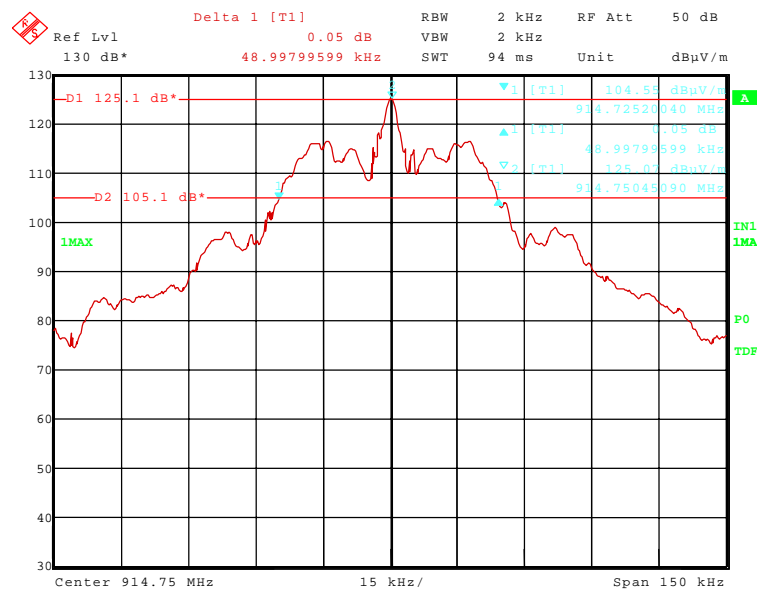

122887\_66.wmf: 20 dB bandwidth at the upper end of the assigned frequency band:

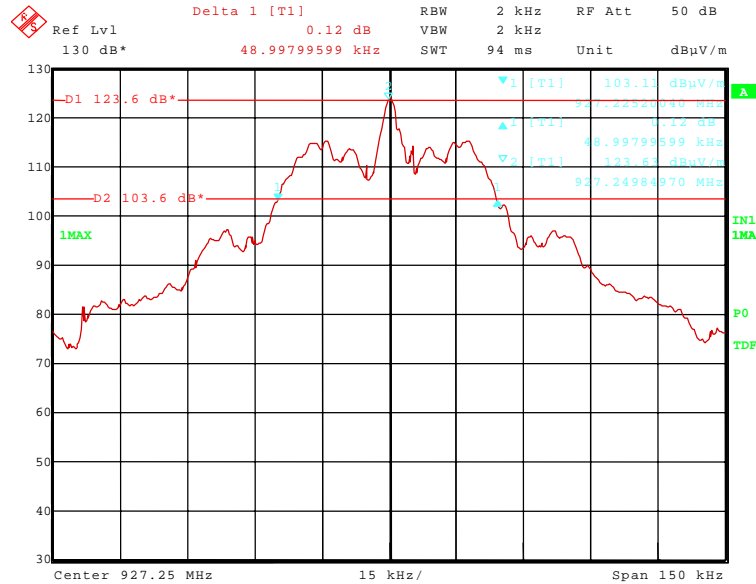

Channel number	Channel frequency [MHz]	20 dB bandwidth [kHz]
0	902.750	49.048096 kHz
24	914.750	48.997996 kHz
49	927.250	48.997996 kHz
Measurement uncertainty		+0.66 dB / -0.72 dB

TEST EQUIPMENT USED FOR THE TEST:

31

## 4.2 Carrier frequency separation

### 4.2.1 Method of measurement (carrier frequency separation)

The calibration of the spectrum analyser has to be checked with the help of a known signal from a signal generator. The EUT has to be connected to the spectrum analyser via a low loss cable. If the EUT is not equipped with an antenna connector, a temporary antenna connector has to be installed. The EUT has to be switched on and the hopping function has to be enabled.

The following spectrum analyser settings shall be used:

- Span: Wide enough to capture the peaks of two adjacent channels.
- Resolution bandwidth:  $\geq 1\%$  of the span.
- Video bandwidth:  $\geq$  the resolution bandwidth.
- Sweep: Auto.
- Detector function: peak.
- Trace mode: Max hold.

After trace stabilisation the marker and the delta marker function will be used to determine the separation between the peaks of two adjacent channel signals.

The measurement will be performed at the upper, the lower end and the middle of the assigned frequency band.

Test set-up:

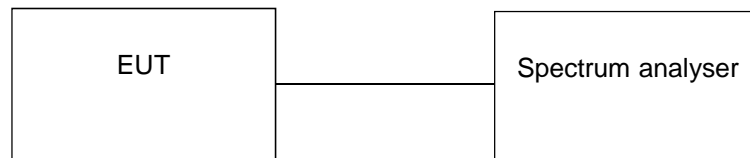

#### 4.2.2 Test results (carrier frequency separation)

Ambient temperature	21 °C	Relative humidity	20 %
---------------------	-------	-------------------	------

122887\_63.wmf: Channel separation at the lower end of the assigned frequency band:

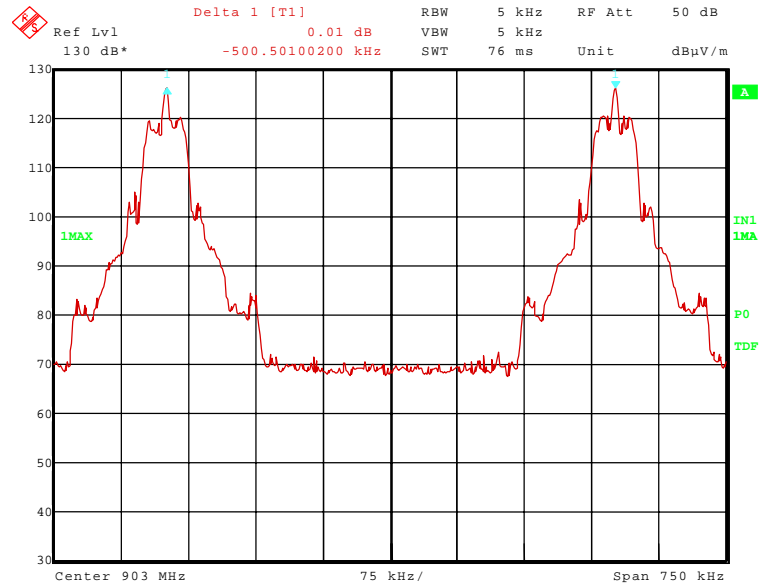

122887\_62.wmf: Channel separation at the middle of the assigned frequency band:

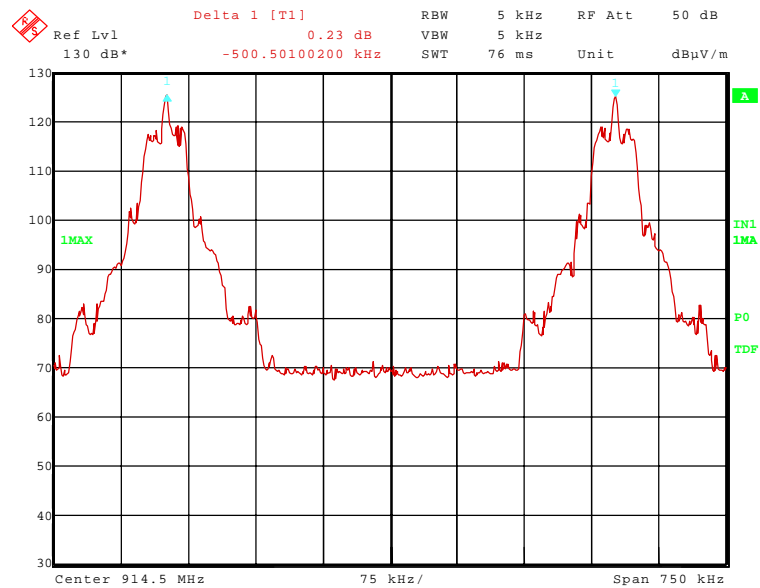

122887\_61.wmf: Channel separation at the upper end of the assigned frequency band:

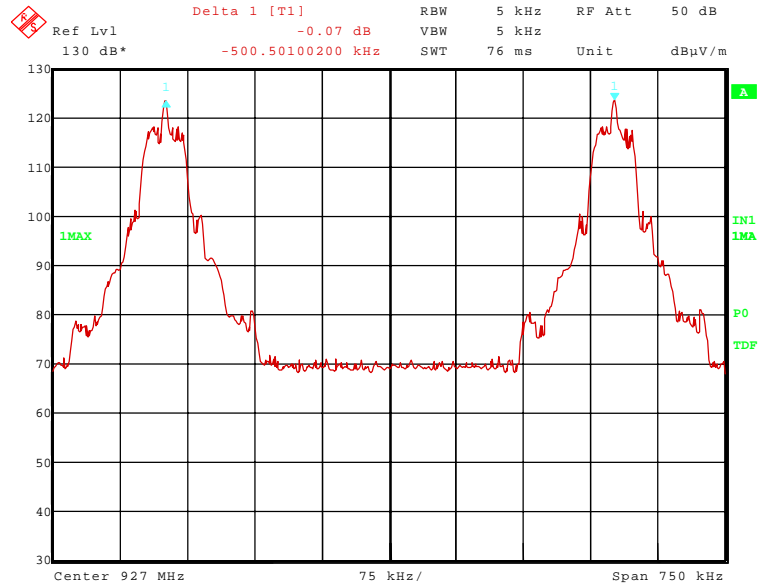

Remark: A smaller Resolution bandwidth was used in order to receive a better optical separation of the signal peaks.

Channel number	Channel frequency [MHz]	Channel separation [kHz]	Minimum limit [kHz]
0	902.750	500.501 kHz	49.048 kHz (the 20 dB bandwidth)
24	914.750	500.501 kHz	48.998 kHz (the 20 dB bandwidth)
49	927.250	500.501 kHz	48.998 kHz (the 20 dB bandwidth)
Measurement uncertainty			$<10^{-7}$

Test: Passed

TEST EQUIPMENT USED FOR THE TEST:
31

## 4.3 Number of hopping frequencies

### 4.3.1 Method of measurement (number of hopping frequencies)

The calibration of the spectrum analyser has to be checked with the help of a known signal from a signal generator. The EUT has to be connected to the spectrum analyser via a low loss cable. If the EUT is not equipped with an antenna connector, a temporary antenna connector has to be installed. The EUT has to be switched on and the hopping function has to be enabled.

The following spectrum analyser settings shall be used:

- Span: Equal to the assigned frequency band.
- Resolution bandwidth:  $\geq 1\%$  of the span.
- Video bandwidth:  $\geq$  the resolution bandwidth.
- Sweep: Auto.
- Detector function: Peak.
- Trace mode: Max hold.

After trace stabilisation the number of hopping channels could be counted. It might be possible to divide the span into some sub ranges in order to clearly show all hopping frequencies.

Test set-up:

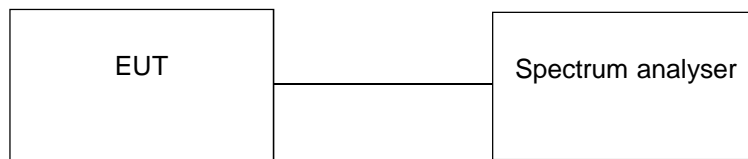

#### 4.3.2 Test results (number of hopping frequencies)

Ambient temperature	21 °C	Relative humidity	20 %
---------------------	-------	-------------------	------

122887\_60.wmf: Number of hopping channels:

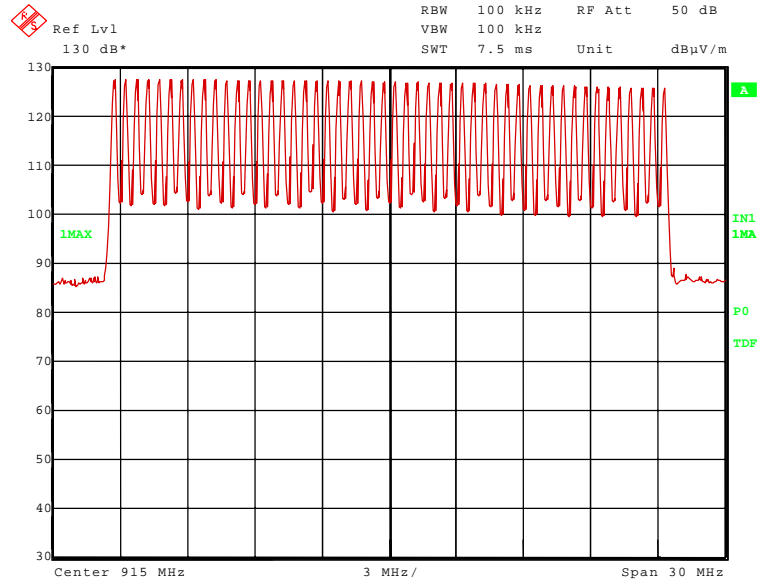

Remark: A smaller Resolution bandwidth was used in order to receive a better optical separation of the signal peaks.

Number of hopping channels	Limit
Operation mode 4	
50	At least 50

Test: Passed

TEST EQUIPMENT USED FOR THE TEST:
31

## 4.4 Dwell time

### 4.4.1 Method of measurement (dwell time)

The calibration of the spectrum analyser has to be checked with the help of a known signal from a signal generator. The EUT has to be connected to the spectrum analyser via a low loss cable. If the EUT is not equipped with an antenna connector, a temporary antenna connector has to be installed. The EUT has to be switched on and the hopping function has to be enabled.

The following spectrum analyser settings shall be used:

- Span: Zero, centred on a hopping channel.
- Resolution bandwidth: 1 MHz.
- Video bandwidth:  $\geq$  the resolution bandwidth.
- Sweep: As necessary to capture the entire dwell time per hopping channel.
- Detector function: peak.
- Trace mode: Max hold.

The marker and delta marker function of the spectrum analyser will be used to determine the dwell time.

The measurement will be performed at the middle of the assigned frequency band.

If the EUT is possible to operate with different mode of operation (data rates, modulation formats etc.) the test will be repeated with every different operation mode of the EUT.

Test set-up:

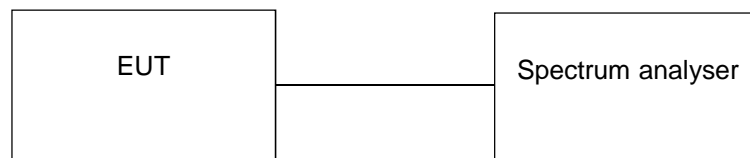



#### 4.4.2 Test results (dwell time)

Ambient temperature	21 °C
---------------------	-------

Relative humidity	24 %
-------------------	------

122887\_67.wmf: Dwell time at the middle of the assigned frequency band:

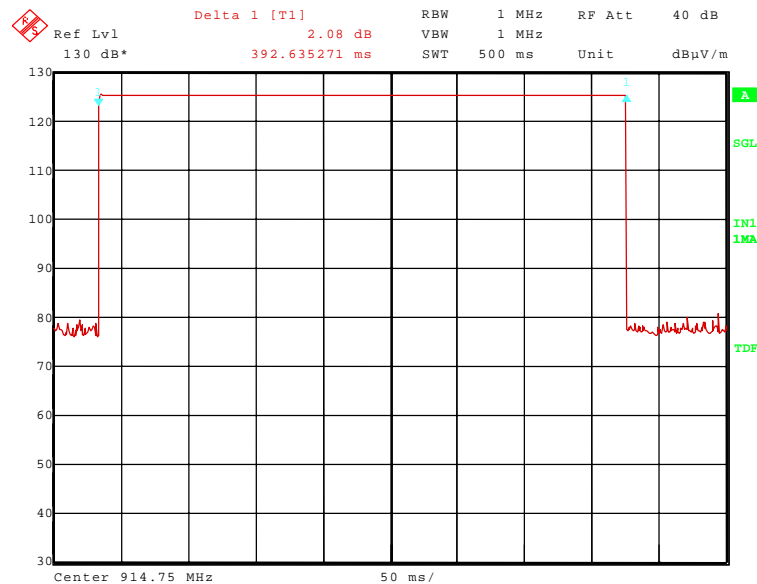

The dwell time is calculated with the following formula:

$$\text{Dwell time} = t_{\text{pulse}} \times n_{\text{hops}} / \text{number of hopping channels} \times 20 \text{ s}$$

Where:

$t_{\text{pulse}}$  is the measured pulse time (pls. refer the plots of the spectrum analyser above) [s],  
 $n_{\text{hops}}$  is the number of hops per second in the actual operating mode of the transmitter [1/s].

The hopping rate of the system is 2.5 hops per second and the system uses 50 channels.

Channel number	Channel frequency [MHz]	$t_{\text{pulse}}$ [ms]	Dwell time [ms]	Limit [ms]
24	914.750	392.625	392.625	400
Measurement uncertainty			<10 <sup>-7</sup>	

Test: Passed

TEST EQUIPMENT USED FOR THE TEST:
31

## 4.5 Maximum peak output power

### 4.5.1 Method of measurement (maximum peak output power)

The calibration of the spectrum analyser has to be checked with the help of a known signal from a signal generator. The EUT has to be connected to the spectrum analyser via a low loss cable. If the EUT is not equipped with an antenna connector, a temporary antenna connector has to be installed. The EUT has to be switched on and the hopping function has to be disenabled.

The following spectrum analyser settings shall be used:

- Span: Approx. 5 times the 20 dB bandwidth, centred on a hopping channel.
- Resolution bandwidth: > the 20 dB bandwidth of the emission being measured.
- Video bandwidth:  $\geq$  the resolution bandwidth.
- Sweep: Auto.
- Detector function: peak.
- Trace mode: Max hold.

After trace stabilisation the marker shall be set on the signal peak. The indicated level is the peak output power, which has to be corrected with the value of the cable loss and an external attenuation (if necessary).

The measurement will be performed at the upper and lower end and the middle of the assigned frequency band.

Test set-up:

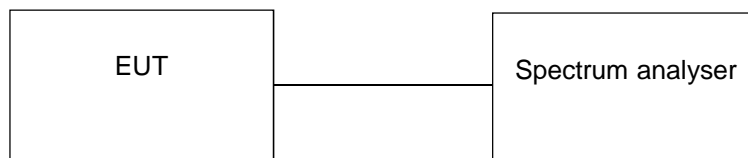

#### 4.5.2 Test results (maximum peak output power)

Ambient temperature	21 °C	Relative humidity	24 %
---------------------	-------	-------------------	------

122887\_89.wmf: Maximum peak output power at the lower end of the assigned frequency band:

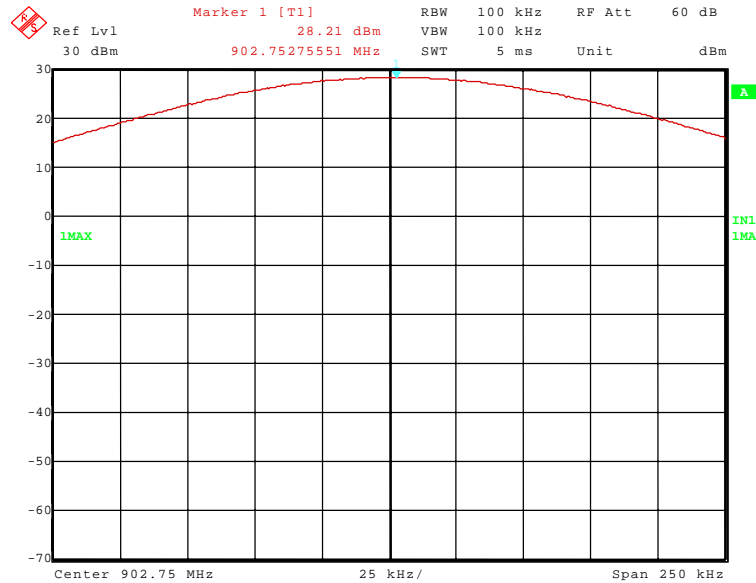

122887\_90.wmf: Maximum peak output power at the middle of the assigned frequency band:

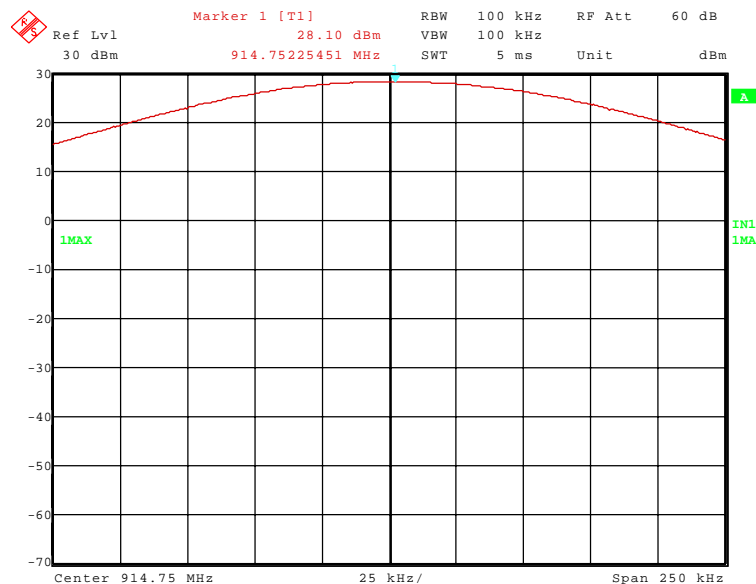

122887\_91.wmf: Maximum peak output power at the upper end of the assigned frequency band:

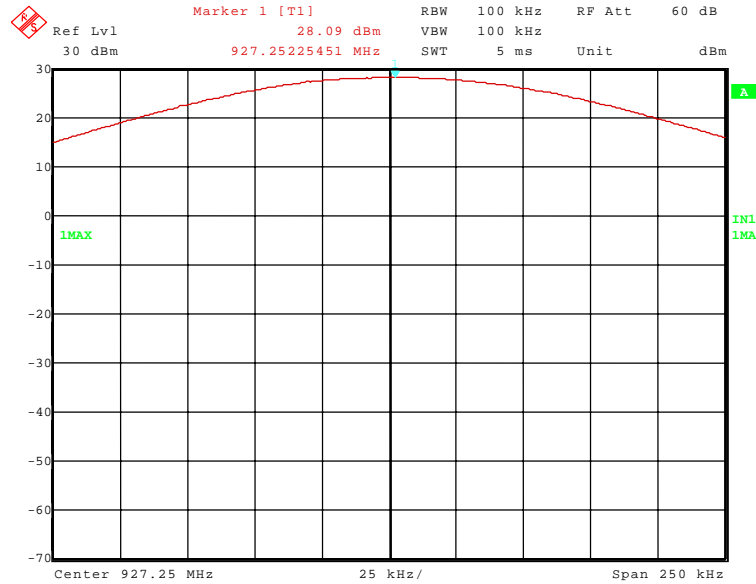

Operation mode	Channel number	Channel frequency [MHz]	Maximum peak output power [dBm]	Antenna gain [dBi]	Peak power limit [dBm]
1	0	902.750	28.2	3.15	30.0
2	24	914.750	28.1	3.15	30.0
3	49	927.250	28.1	3.15	30.0
Measurement uncertainty				+0.66 dB / -0.72 dB	

Test:      Passed

TEST EQUIPMENT USED FOR THE TEST:
31

## 4.6 Radiated emissions

### 4.6.1 Method of measurement (radiated emissions)

The radiated emission measurement is subdivided into four stages.

- A preliminary measurement carried out in a fully anechoic chamber with a fixed antenna height in the frequency range 30 MHz to 1 GHz.
- A final measurement carried out on an open area test site with reflecting ground plane and various antenna height in the frequency range 30 MHz to 1 GHz.
- A preliminary measurement carried out in a fully anechoic chamber with a variable antenna distance and height in the frequency range 1 GHz to 110 GHz.
- A final measurement carried out in a fully anechoic chamber with a fixed antenna height in the frequency range 1 GHz to 110 GHz.

All measurements will be carried out with the EUT working on the middle of the assigned frequency band.

#### Preliminary measurement (30 MHz to 1 GHz)

In the first stage a preliminary measurement will be performed in a fully anechoic chamber with a measuring distance of 3 meter. Tabletop devices will set up on a non-conducting support with a size of 1 m by 1.5 m and a height of 80 cm. Floor-standing devices will be placed directly on the turntable/ground plane. The setup of the Equipment under test will be in accordance to ANSI C63.4-2009 [1].

The frequency range 30 MHz to 1 GHz will be measured with an EMI Receiver set to MAX Hold mode and a resolution bandwidth of 100 kHz. The measurement will be performed in horizontal and vertical polarisation of the measuring antenna and while rotating the EUT in its vertical axis in the range of 0 ° to 360 °.

The resolution bandwidth of the EMI Receiver will be set to the following values:

Frequency range	Resolution bandwidth
30 MHz to 200 MHz	100 kHz
200 MHz to 1 GHz	100 kHz

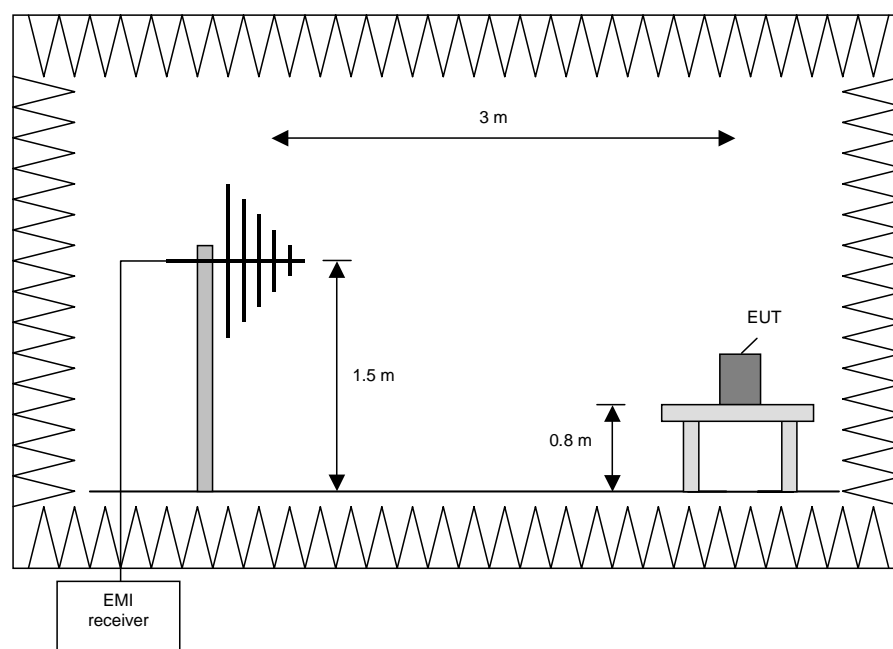

### Procedure preliminary measurement:

Prescans were performed in the frequency range 30 MHz to 200 MHz and 200 MHz to 1 GHz.

The following procedure will be used:

1. Monitor the frequency range at horizontal polarisation and a EUT azimuth of 0 °.
2. Manipulate the system cables within the range to produce the maximum level of emission.
3. Rotate the EUT by 360 ° to maximize the detected signals.
4. Make a hardcopy of the spectrum.
5. Measure the frequency of the detected emissions with a lower span and resolution bandwidth to increase the accuracy and note the frequency value.
6. Repeat 1) to 4) with the other orthogonal axes of the EUT (because of EUT is a module and might be used in a handheld equipment application).
7. Repeat 1) to 5) with the vertical polarisation of the measuring antenna.

### Final measurement (30 MHz to 1 GHz)

A final measurement on an open area test site will be performed on selected frequencies found in the preliminary measurement. During this test the EUT will be rotated in the range of 0 ° to 360 °, the measuring antenna will be set to horizontal and vertical polarisation and raised and lowered in the range from 1 m to 4 m to find the maximum level of emissions.

The resolution bandwidth of the EMI Receiver will be set to the following values:

Frequency range	Resolution bandwidth
30 MHz to 1 GHz	120 kHz

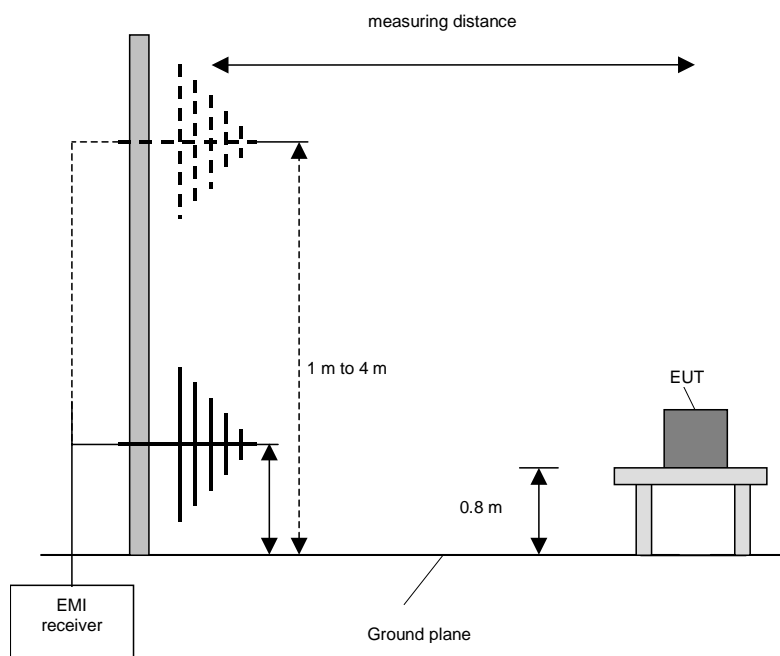

Procedure final measurement:

The following procedure will be used:

- 1) Measure on the selected frequencies at an antenna height of 1 m and a EUT azimuth of 23 °.
- 2) Move the antenna from 1 m to 4 m and note the maximum value at each frequency.
- 3) Rotate the EUT by 45 ° and repeat 2) until an azimuth of 337 ° is reached.
- 4) Repeat 1) to 3) for the other orthogonal antenna polarization.
- 5) Move the antenna and the turntable to the position where the maximum value is detected.
- 6) Measure while moving the antenna slowly +/- 1 m.
- 7) Set the antenna to the position where the maximum value is found.
- 8) Measure while moving the turntable +/- 45 °.
- 9) Set the turntable to the azimuth where the maximum value is found.
- 10) Measure with Final detector (QP and AV) and note the value.
- 11) Repeat 5) to 10) for each frequency.
- 12) Repeat 1) to 11) for each orthogonal axes of the EUT (because of EUT is a module and might be used in a handheld equipment application).

**Preliminary and final measurement (1 GHz to 110 GHz)**

This measurement will be performed in a fully anechoic chamber. Tabletop devices will set up on a non-conducting support with a size of 1 m by 1.5 m and a height of 80 cm. Floor-standing devices will be placed directly on the turntable/ground plane. The setup of the Equipment under test will be in accordance to ANSI C63.4-2009 [1].

**Preliminary measurement (1 GHz to 110 GHz)**

The frequency range will be divided into different sub ranges depending of the frequency range of the used horn antenna. The spectrum analyser set to MAX Hold mode and a resolution bandwidth of 100 kHz. The measurement will be performed in horizontal and vertical polarisation of the measuring antenna, the antenna close to the EUT and while moving the antenna over all sides of the EUT. With the spectrum analyser in CLEAR / WRITE mode the cone of the emission should be found and than the measuring distance will be set to 3 m with the receiving antenna moving in this cone of emission. At this position the final measurement will be carried out.

The resolution bandwidth of the EMI Receiver will be set to the following values:

Frequency range	Resolution bandwidth
1 GHz to 4 GHz	100 kHz
4 GHz to 12 GHz	100 kHz
12 GHz to 18 GHz	100 kHz
18 GHz to 26.5 GHz	100 kHz
26.5 GHz to 40 GHz	100 kHz
40 GHz to 60 GHz	100 kHz
50 GHz to 75 GHz	100 kHz
75 GHz to 110 GHz	100 kHz

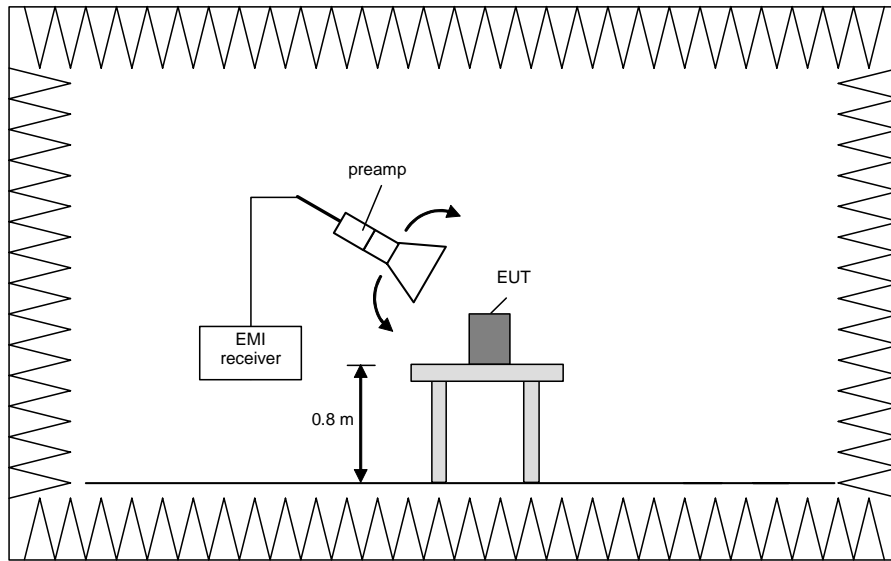

### **Final measurement (1 GHz to 110 GHz)**

The frequency range will be divided into different sub ranges depending of the frequency range of the used horn antenna. The EMI Receiver set to peak and average mode and a resolution bandwidth of 1 MHz. The measurement will be performed in horizontal and vertical polarisation of the measuring antenna and while rotating the EUT in its vertical axis in the range of 0 ° to 360 ° in order to have the antenna inside the cone of radiation.

The resolution bandwidth of the EMI Receiver will be set to the following values:

Frequency range	Resolution bandwidth
1 GHz to 4 GHz	1 MHz
4 GHz to 12 GHz	1 MHz
12 GHz to 18 GHz	1 MHz
18 GHz to 26.5 GHz	1 MHz
26.5 GHz to 40 GHz	1 MHz
40 GHz to 60 GHz	1 MHz
50 GHz to 75 GHz	1 MHz
75 GHz to 110 GHz	1 MHz



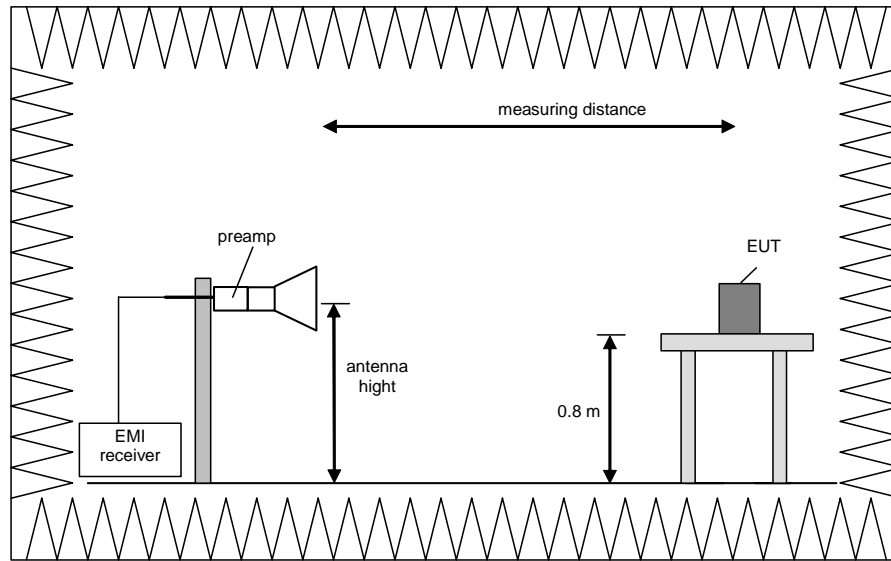

#### Procedure of measurement:

The measurements were performed in the frequency range 1 GHz to 4 GHz, 4 GHz to 12 GHz, 12 GHz to 18 GHz, 18 GHz to 26.5 GHz, 26.5 GHz to 40 GHz, 40 GHz to 60 GHz, 60 GHz to 75 GHz and 75 GHz to 110 GHz.

The following procedure will be used:

- 1) Monitor the frequency range at horizontal polarisation and move the antenna over all sides of the EUT (if necessary move the EUT to another orthogonal axis).
- 2) Change the antenna polarisation and repeat 1) with vertical polarisation.
- 3) Make a hardcopy of the spectrum.
- 4) Measure the frequency of the detected emissions with a lower span and resolution bandwidth to increase the accuracy and note the frequency value.
- 5) Change the analyser mode to Clear / Write and found the cone of emission.
- 6) Rotate and move the EUT, so that the measuring distance can be enlarged to 3 m and the antenna will be still inside the cone of emission.
- 7) Measure the level of the detected frequency with the correct resolution bandwidth, with the antenna polarisation and azimuth and the peak and average detector, which causes the maximum emission.
- 8) Repeat steps 1) to 7) for the next antenna spot if the EUT is larger than the antenna beamwidth.

Step 1) to 6) are defined as preliminary measurement.

## 4.6.2 Test results (radiated emissions)

### 4.6.2.1 Preliminary radiated emission measurement

Ambient temperature	21 °C	Relative humidity	26 %
---------------------	-------	-------------------	------

Position of EUT: The EUT was set-up on a non-conducting table of a height of 0.8 m. The distance between EUT and antenna was 3 m.

Test record: All results are shown in the following.

Supply voltage: During all measurements the EUT was supplied with 12 V DC by an external power supply.

Remark: As pre-tests have shown, the emissions in the frequency range 10 MHz to 30 MHz are not depending on the transmitter operation mode. Therefore the emissions in this frequency range were measured only with the transmitter operates in operation mode 2.

#### Transmitter operates at the lower end of the assigned frequency band (operation mode 1)

122887\_71.wmf: Spurious emissions from 30 MHz to 200 MHz (operation mode 1):

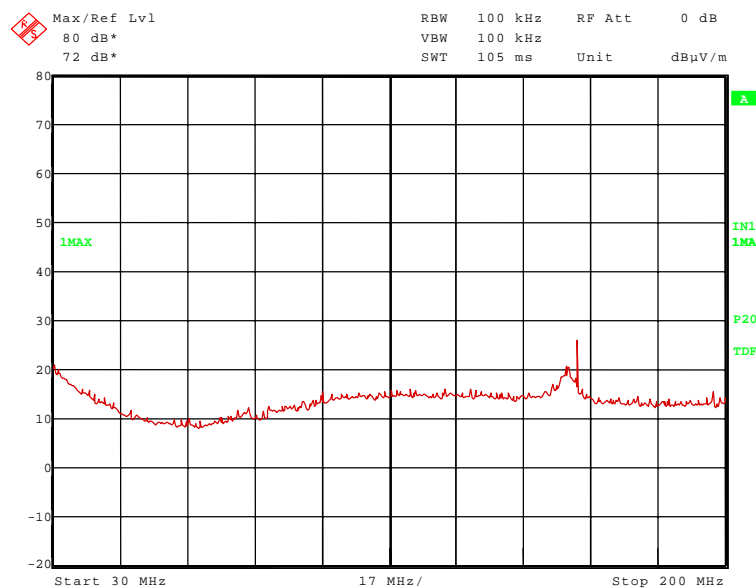

122887\_70.wmf: Spurious emissions from 200 MHz to 1 GHz (operation mode 1, carrier notched):

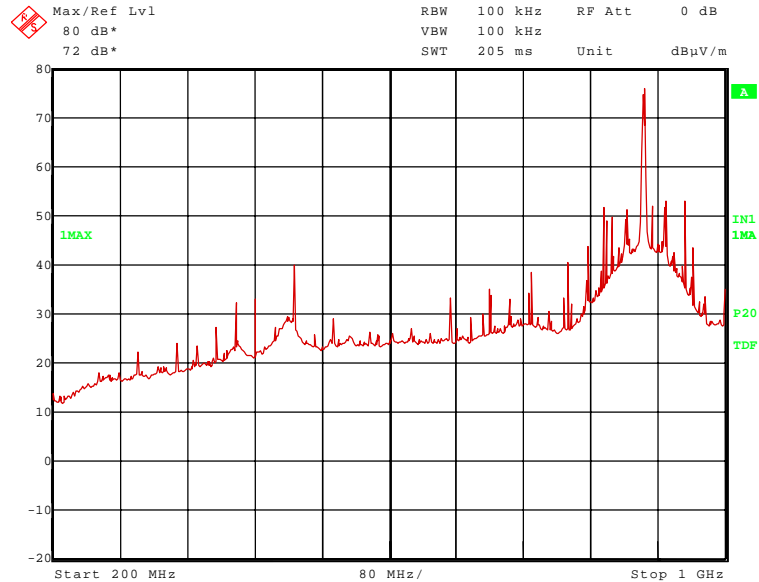

The following frequencies were found outside the restricted bands during the preliminary radiated emission test:

- 440.800 MHz, 487.200 MHz, 768.000 MHz, 812.000 MHz, 854.700 MHz, 881.600 MHz, 902.750 MHz, 903.040 MHz, 928.00 MHz and 950.750 MHz.

The following frequencies were found inside the restricted bands during the preliminary radiated emission test:

- 162.400 MHz and 960.000 MHz.

These frequencies have to be measured on the open area test site. The result is presented in the following.

122887\_73.wmf: Spurious emissions from 1 GHz to 4 GHz (operation mode 1):

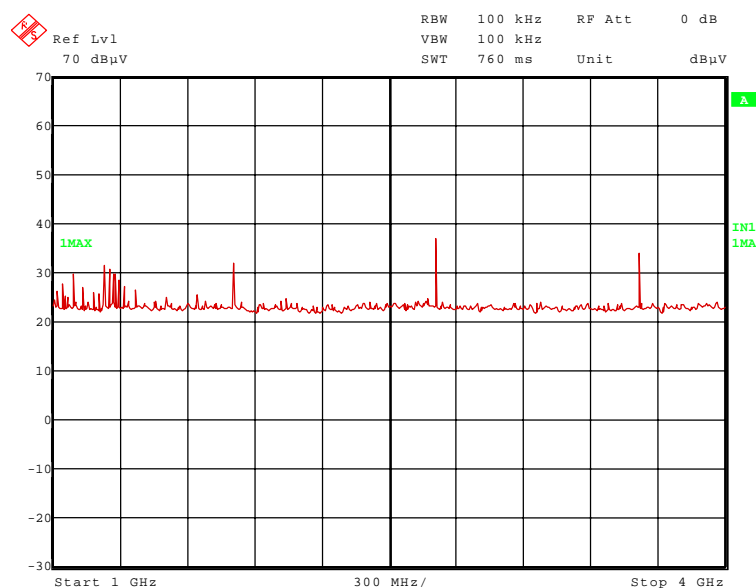

122887\_78.wmf: Spurious emissions from 4 GHz to 12 GHz (operation mode 1):

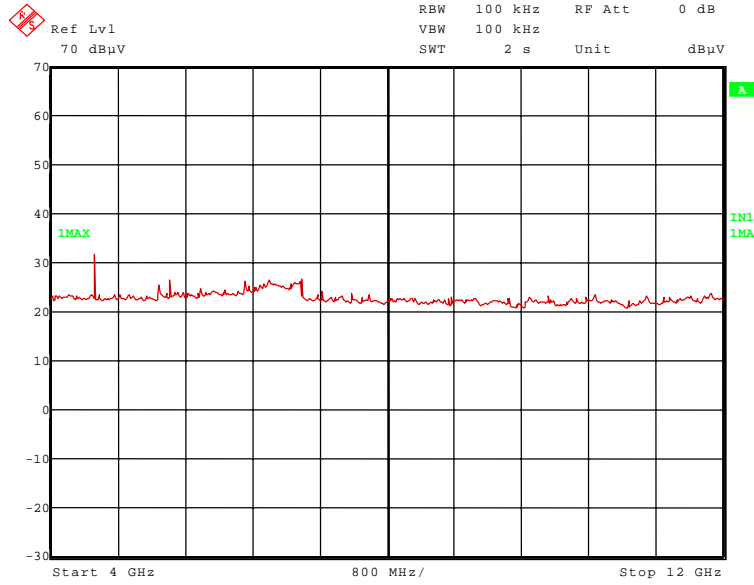

122887\_79.wmf: Spurious emissions from 12 GHz to 18 GHz (operation mode 1):

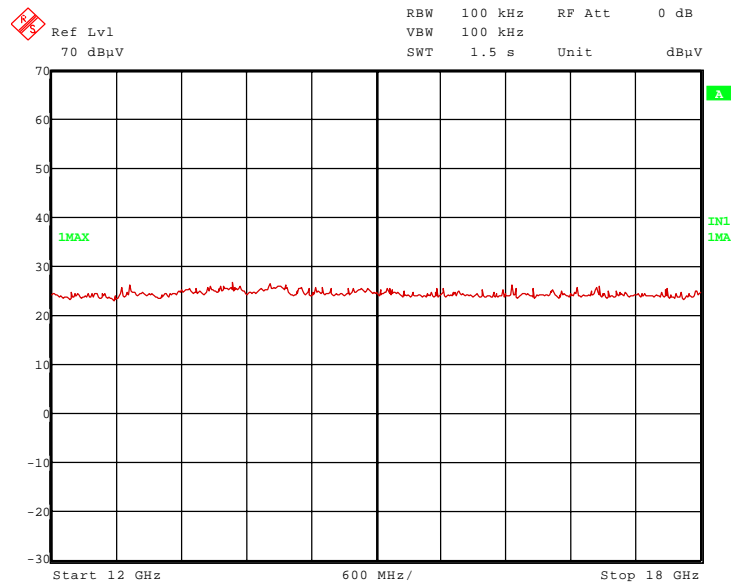

122887\_84.wmf: Spurious emissions from 18 GHz to 26.5 GHz (operation mode 1):

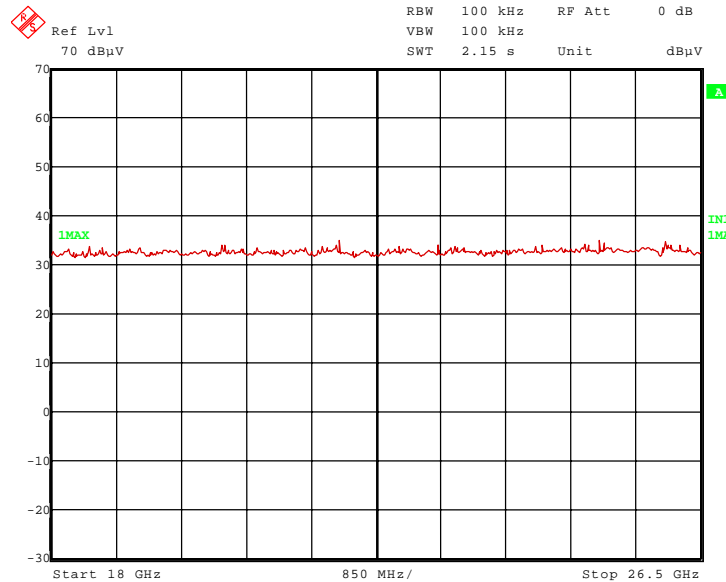

122887\_85.wmf: Spurious emissions from 26.5 GHz to 40 GHz (operation mode 1):

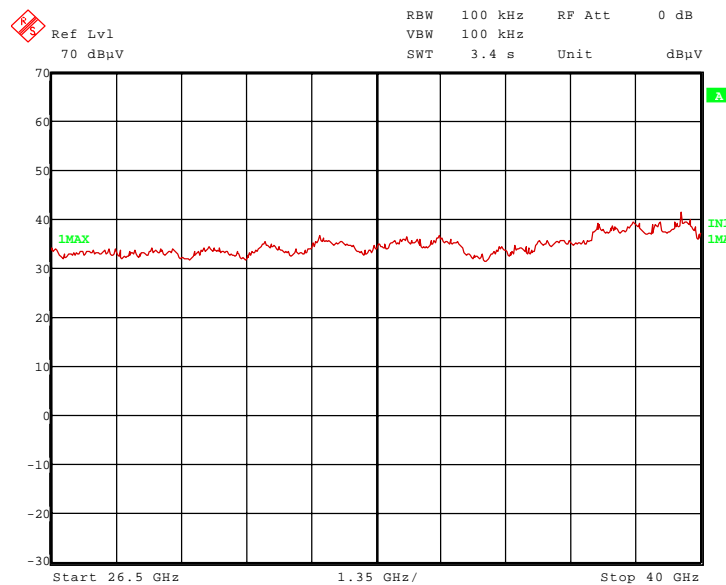

The following frequencies were found inside the restricted bands during the preliminary radiated emission test:

- 1.22958 GHz, 2.70825GHz, 3.611 GHz, 4.51375 GHz and 5.4165 GHz.

The following frequency was found outside the restricted bands during the preliminary radiated emission test:

- 1.8055 GHz.

These frequencies have to be measured in a final measurement. The results were presented in the following.

**Transmitter operates on the middle of the assigned frequency band (operation mode 2)**

122887\_88.wmf: Spurious emissions from 10 MHz to 30 MHz (operation mode 2):

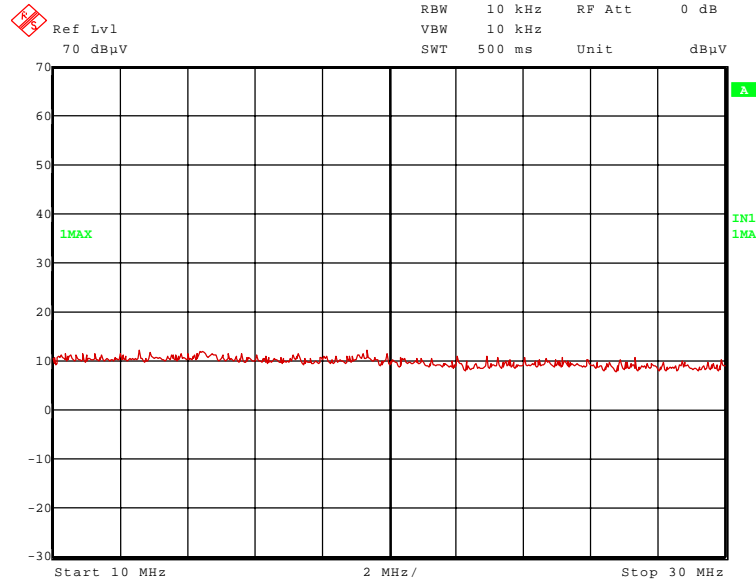

No significant frequencies above the noise floor of the system were found during the preliminary radiated emission test, so no measurements were carried out on the outdoor test site.

122887\_69.wmf: Spurious emissions from 30 MHz to 200 MHz (operation mode 2):

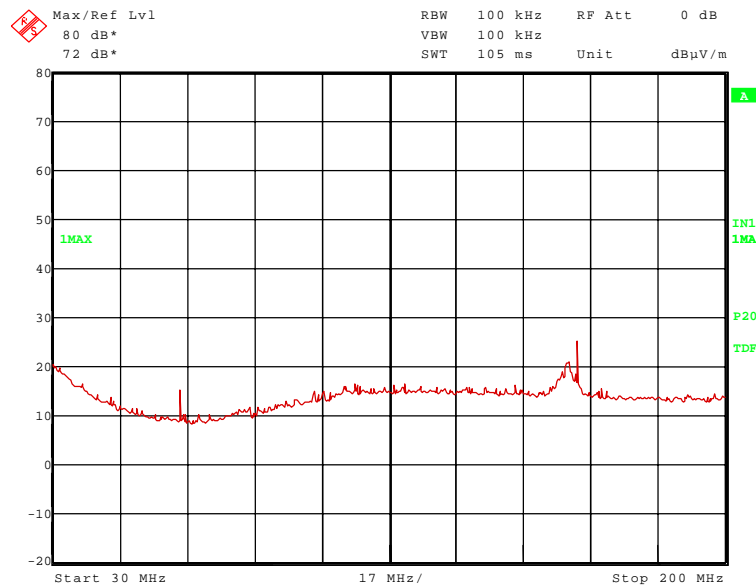

122887\_68.wmf: Spurious emissions from 200 MHz to 1 GHz (operation mode 2, carrier notched):

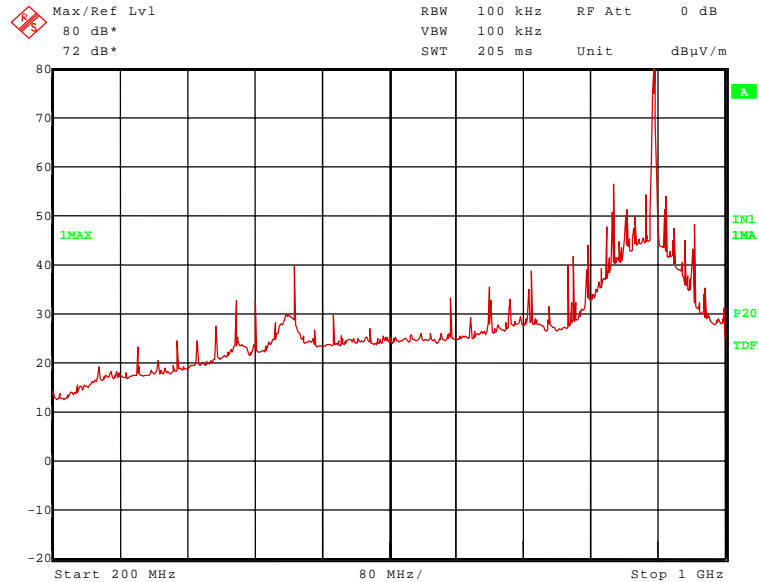

The following frequencies were found outside the restricted bands during the preliminary radiated emission test:

- 417.600 MHz, 487.200 MHz, 768.000 MHz, 812.000 MHz, 818.750 MHz, 835.200 MHz, 858.400 MHz, 904.800 MHz, 914.750 MHz, 928.000 MHz and 951.200 MHz.

The following frequencies were found inside the restricted bands during the preliminary radiated emission test:

- 162.400 MHz and 962.750 MHz.

These frequencies have to be measured on the open area test site. The result is presented in the following.

122887\_74.wmf: Spurious emissions from 1 GHz to 4 GHz (operation mode 2):

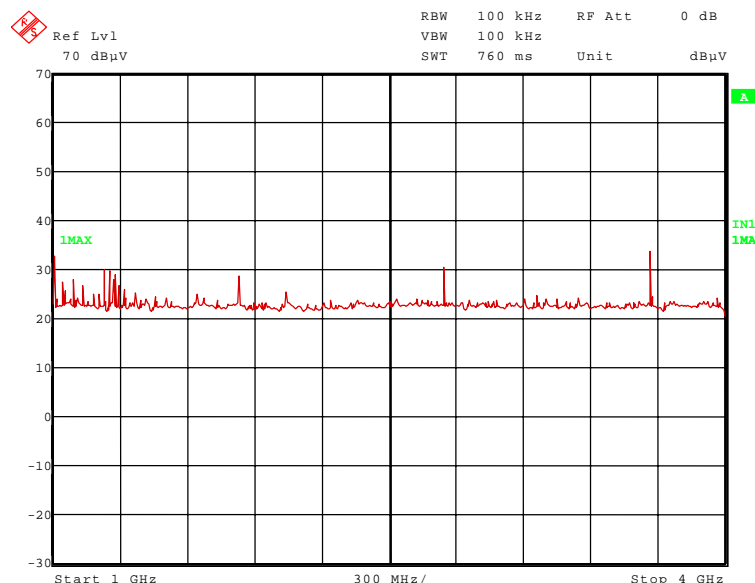

122887\_77.wmf: Spurious emissions from 4 GHz to 12 GHz (operation mode 2):

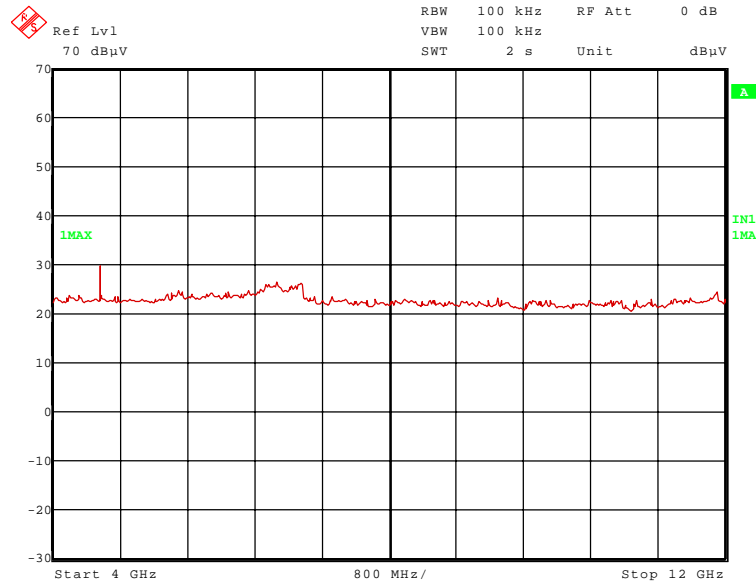

122887\_80.wmf: Spurious emissions from 12 GHz to 18 GHz (operation mode 2):

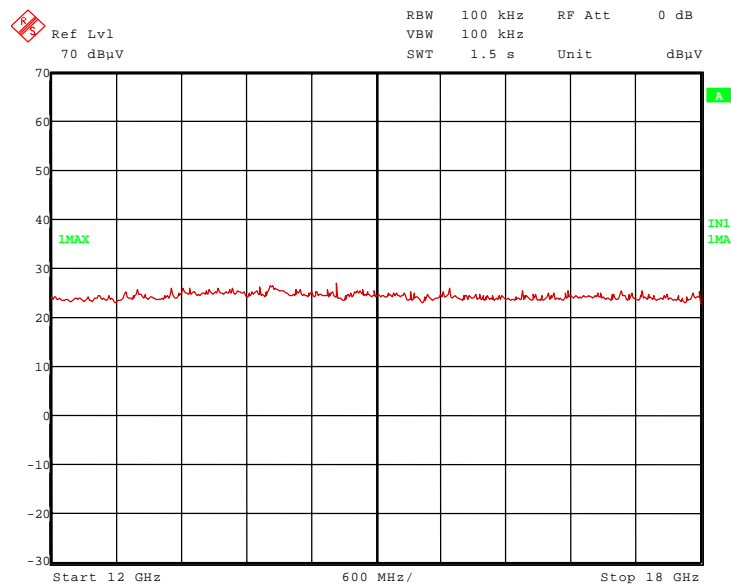









122887\_81.wmf: Spurious emissions from 12 GHz to 18 GHz (operation mode 3):

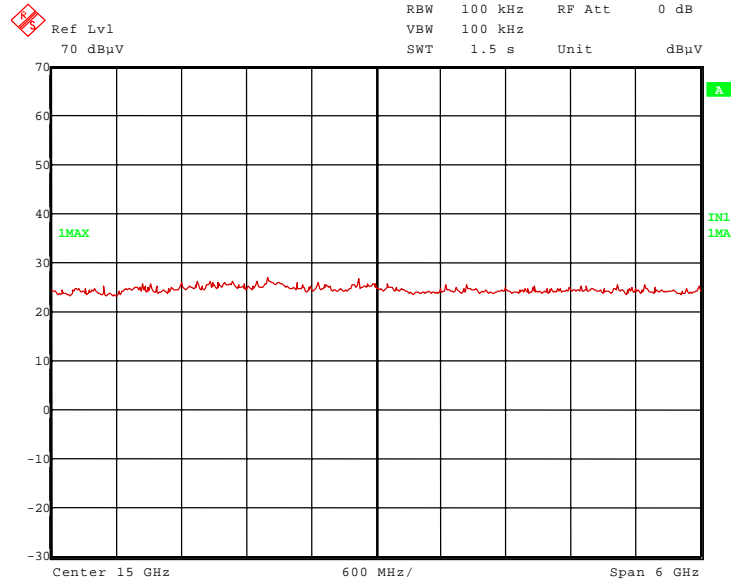

122887\_82.wmf: Spurious emissions from 18 GHz to 26.5 GHz (operation mode 3):

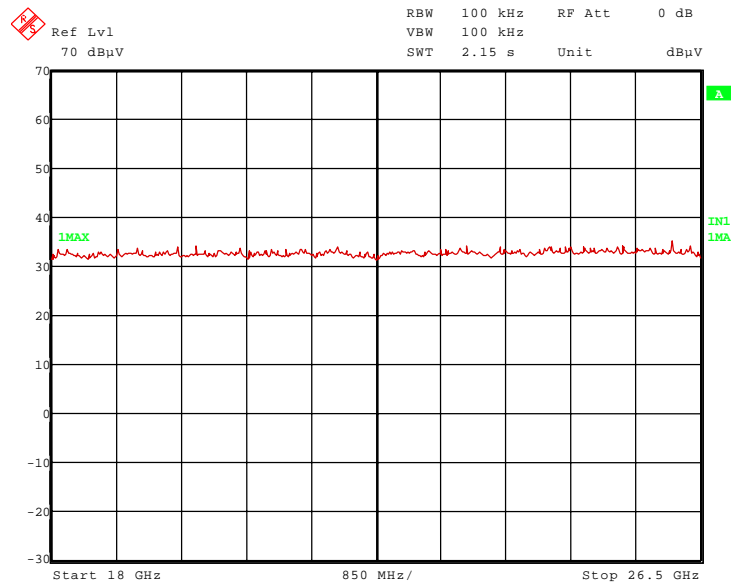

122887\_87.wmf: Spurious emissions from 26.5 GHz to 40 GHz (operation mode 3):

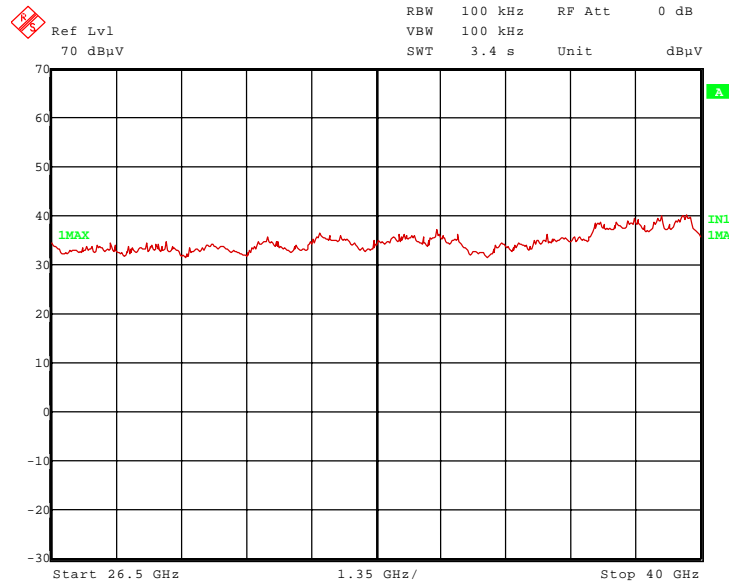

The following frequencies were found inside the restricted bands during the preliminary radiated emission test:

- 1.0233 GHz, 2.78175 GHz, 3.709 GHz, 4.63625 GHz and 7.418 GHz.

The following frequencies were found outside the restricted bands during the preliminary radiated emission test:

- 1.2528 GHz and 1.8545 GHz.

These frequencies have to be measured in a final measurement. The results were presented in the following.

**TEST EQUIPMENT USED FOR THE TEST:**

29, 31 - 36, 43, 44, 45, 49, 55, 73, 75, 83. 146, 149, 150, 159 – 161, 165

#### 4.6.2.2 Final radiated emission measurement (30 MHz to 1 GHz) with internal antenna

Ambient temperature	21 °C	Relative humidity	33 %
---------------------	-------	-------------------	------

Position of EUT: The EUT was set-up on a non-conducting table of a height of 0.8 m. The distance between EUT and antenna was 3 m.

Test record: All results are shown in the following.

Supply voltage: During all measurements the EUT was supplied with 12 V DC by an external power supply.

Test results: The test results were calculated with the following formula:

$$\text{Result [dB}\mu\text{V/m]} = \text{reading [dB}\mu\text{V]} + \text{cable loss [dB]} + \text{antenna factor [dB/m]}$$

The measured points and the limit line in the following diagrams refer to the standard measurement of the emitted interference in compliance with the above-mentioned standard. The measured points marked with an x are the measured results of the standard final measurement on the open area test site.

The results of the standard subsequent measurement on the open area test site are indicated in the table below. The limits as well as the measured results (levels) refer to the above mentioned standard while taking account of the specified requirements for a 3 m measuring distance.

The measurement time with the quasi-peak measuring detector is 1 second.

#### Transmitter operates on the lower end of the assigned frequency (operation mode 1)

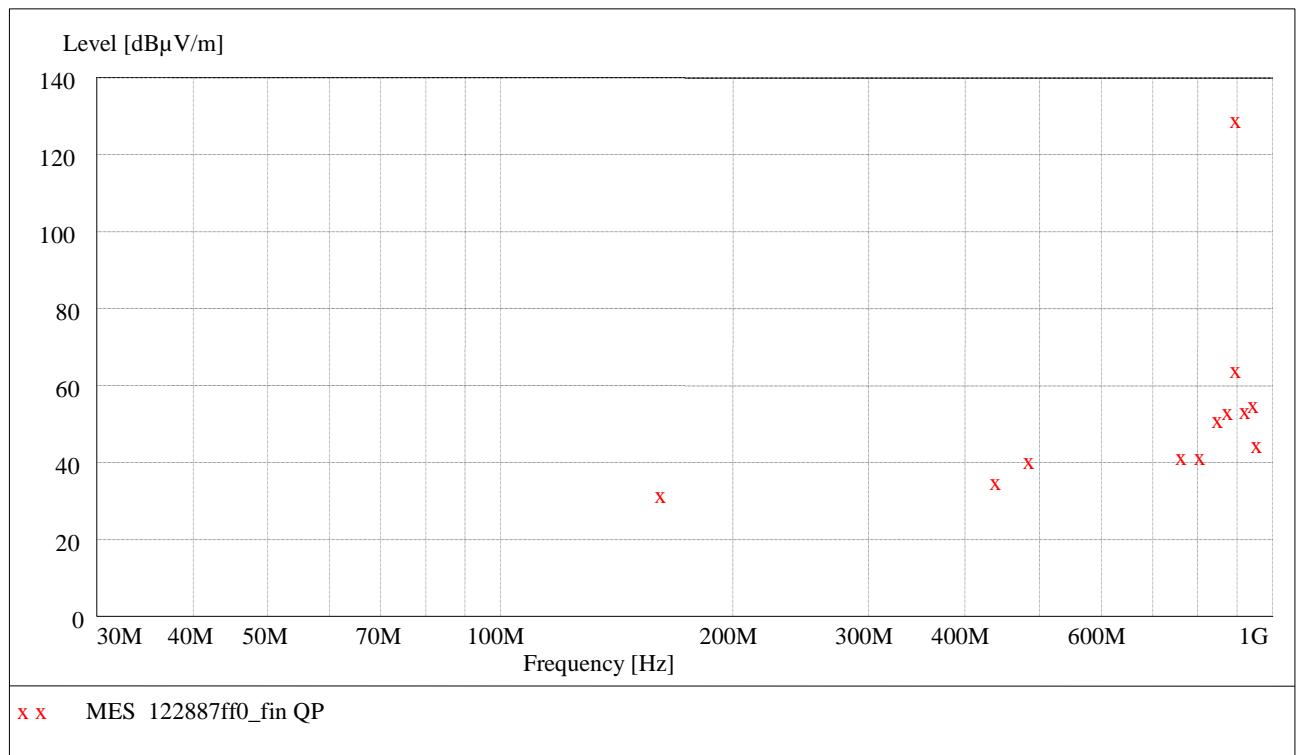

Data record name: 122887ff0

**Result measured with the quasi-peak detector:**  
(These values were marked in the diagrams by an x)

Transmitter operates on the lower end of the assigned frequency band (operation mode 1)									
Spurious emissions outside restricted bands									
Frequency MHz	Result dB $\mu$ V/m	Limit dB $\mu$ V/m	Margin dB	Readings dB $\mu$ V	Antenna factor dB/m	Cable loss dB	Height cm	Azimuth deg	Pol.
440.800	35.9	109.9	74.0	17.1	16.4	2.4	156.0	353.0	Hor.
487.200	41.3	109.9	68.6	21.6	17.2	2.5	100.0	0.0	Vert.
768.000	42.4	109.9	67.5	17.7	21.5	3.2	145.0	0.0	Hor.
812.000	42.3	109.9	67.6	17.5	21.6	3.2	178.0	59.0	Hor.
854.700	52.0	109.9	57.9	26.3	22.4	3.3	186.0	26.0	Hor.
881.600	54.0	109.9	55.9	28.5	22.0	3.5	188.0	28.0	Hor.
902.750	129.9	-	-	104.0	22.5	3.4	175.0	0.0	Hor.
903.040	65.0	109.9	44.9	39.1	22.5	3.4	175.0	0.0	Hor.
928.000	54.2	109.9	55.7	27.4	23.4	3.4	100.0	0.0	Vert.
950.750	55.9	109.9	54.0	28.5	23.9	3.5	103.0	15.0	Hor.
Spurious emissions inside restricted bands									
Frequency MHz	Result dB $\mu$ V/m	Limit dB $\mu$ V/m	Margin dB	Readings dB $\mu$ V	Antenna factor dB/m	Cable loss dB	Height cm	Azimuth deg	Pol.
162.400	32.3	43.5	11.2	19.9	11.0	1.4	138.0	135.0	Hor.
960.000	45.5	54.0	8.5	18.2	23.8	3.5	115.0	17.0	Hor.
Measurement uncertainty				+2.2 dB / -3.6 dB					

**Transmitter operates on the middle of the assigned frequency (operation mode 2)**

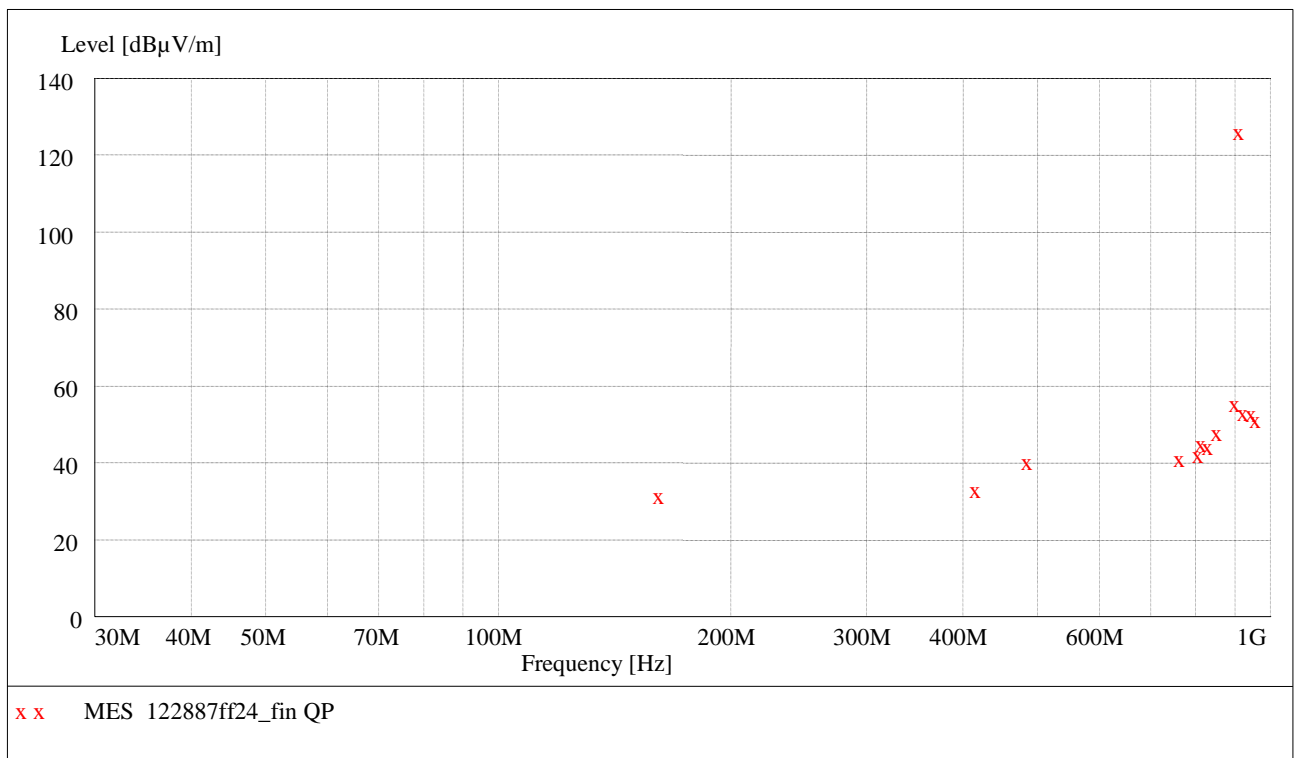

Data record name: 122887ff24

Transmitter operates on the middle of the assigned frequency band (operation mode 2)									
Spurious emissions outside restricted bands									
Frequency MHz	Result dB $\mu$ V/m	Limit dB $\mu$ V/m	Margin dB	Readings dB $\mu$ V	Antenna factor dB/m	Cable loss dB	Height cm	Azimuth deg	Pol.
417.600	33.9	106.7	72.8	15.6	16.0	2.3	183.0	2.0	Hor.
487.200	41.2	106.7	65.5	21.5	17.2	2.5	100.0	0.0	Vert.
768.000	42.0	106.7	64.7	17.3	21.5	3.2	140.0	2.0	Hor.
812.000	43.0	106.7	63.7	18.2	21.6	3.2	100.0	32.0	Vert.
818.750	45.8	106.7	60.8	20.7	21.9	3.2	213.0	21.0	Hor.
835.200	45.1	106.7	61.6	19.3	22.6	3.2	249.0	315.0	Hor.
858.400	48.6	106.7	58.1	23.0	22.3	3.3	146.0	19.0	Vert.
904.800	56.3	106.7	50.4	30.4	22.5	3.4	175.0	331.0	Hor.
914.750	126.7	-	-	100.5	22.8	3.4	149.0	22.0	Vert.
928.000	53.7	106.7	53.0	26.9	23.4	3.4	100.0	3.0	Vert.
951.200	53.5	106.7	53.2	26.1	23.9	3.5	305.0	309.0	Vert.
Spurious emissions inside restricted bands									
Frequency MHz	Result dB $\mu$ V/m	Limit dB $\mu$ V/m	Margin dB	Readings dB $\mu$ V	Antenna factor dB/m	Cable loss dB	Height cm	Azimuth deg	Pol.
162.400	32.1	43.5	11.4	19.7	11.0	1.4	136.0	135.0	Hor.
962.750	52.0	54.0	2.0	24.7	23.8	3.5	106.0	3.0	Hor.
Measurement uncertainty				+2.2 dB / -3.6 dB					

**Transmitter operates on the upper end of the assigned frequency (operation mode 3)**

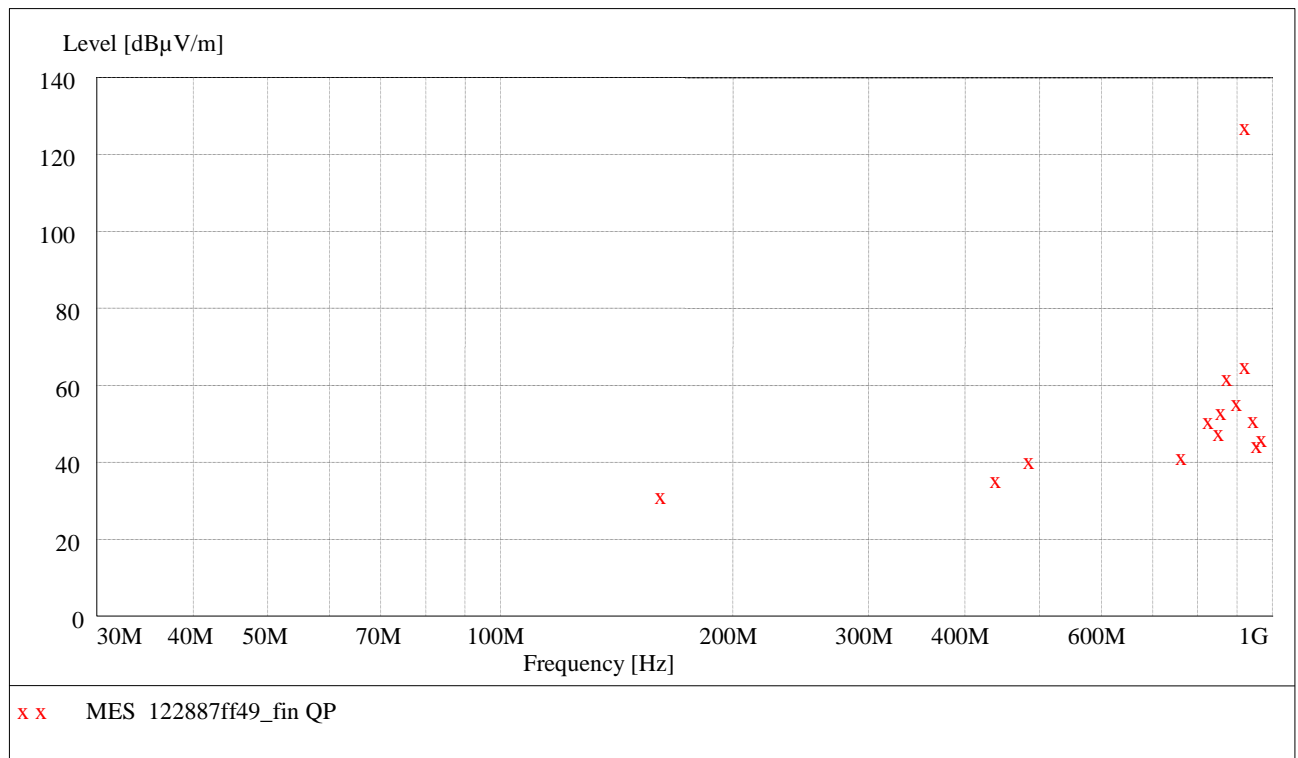

Data record name: 122887ff49



Transmitter operates on the upper end of the assigned frequency band (operation mode 3)									
Spurious emissions outside restricted bands									
Frequency MHz	Result dB $\mu$ V/m	Limit dB $\mu$ V/m	Margin dB	Readings dB $\mu$ V	Antenna factor dB/m	Cable loss dB	Height cm	Azimuth deg	Pol.
440.800	36.1	108.0	71.9	17.3	16.4	2.4	155.0	354.0	Hor.
487.200	41.2	108.0	66.8	21.5	17.2	2.5	100.0	0.0	Vert.
768.000	42.2	108.0	65.8	17.5	21.5	3.2	143.0	11.0	Hor.
831.250	51.6	108.0	56.4	25.9	22.5	3.2	199.0	29.0	Hor.
858.400	48.5	108.0	59.5	22.9	22.3	3.3	144.0	27.0	Vert.
864.000	54.0	108.0	54.0	28.4	22.2	3.4	189.0	26.0	Hor.
879.250	62.8	108.0	45.2	37.4	22.0	3.4	197.0	0.0	Hor.
904.800	56.3	108.0	51.7	30.4	22.5	3.4	175.0	329.0	Hor.
927.250	128.0	-	-	101.2	23.4	3.4	100.0	0.0	Vert.
927.570	66.0	108.0	42.0	39.2	23.4	3.4	100.0	7.0	Vert.
951.200	51.8	108.0	56.2	24.4	23.9	3.5	260.0	1.0	Vert.
Spurious emissions inside restricted bands									
Frequency MHz	Result dB $\mu$ V/m	Limit dB $\mu$ V/m	Margin dB	Readings dB $\mu$ V	Antenna factor dB/m	Cable loss dB	Height cm	Azimuth deg	Pol.
162.400	32.1	43.5	11.4	19.7	11.0	1.4	141.0	135.0	Hor.
960.000	45.4	54.0	8.6	18.1	23.8	3.5	115.0	15.0	Hor.
975.250	46.8	54.0	7.2	19.5	23.8	3.5	150.0	9.0	Hor.
Measurement uncertainty				+2.2 dB / -3.6 dB					

Test: Passed

TEST EQUIPMENT USED FOR THE TEST:

14 - 20

#### 4.6.2.3 Final radiated emission measurement (1 GHz to 40 GHz) with internal antenna

Ambient temperature	21 °C	Relative humidity	26 %
---------------------	-------	-------------------	------

Position of EUT: The EUT was set-up on a non-conducting table of a height of 0.8 m. The distance between EUT and antenna was 3 m.

Test record: All results are shown in the following.

Supply voltage: During all measurements the EUT was supplied with 12 V DC by an external power supply.

Resolution bandwidth: For all measurements a resolution bandwidth of 1 MHz was used.

#### Transmitter operates at the lower end of the assigned frequency band (operation mode 1)

##### Result measured with the peak detector:

Frequency GHz	Corr. Value dBµV/m	Limit dBµV/m	Margin dB	Readings dBµV	Antenna factor 1/m	Preamp dB	Cable loss dB	Height cm	Pol.	Restr. Band
1.22958	38.9	74.0	35.1	37.8	24.9	26.5	2.7	150	Hor.	Yes
1.80550	40.3	109.9	69.6	37.3	26.5	26.5	3.0	150	Vert.	No
2.70825	50.5	74.0	23.5	44.2	28.7	26.4	4.0	150	Hor.	Yes
3.61100	47.7	74.0	26.3	38.0	31.3	26.2	4.6	150	Vert.	Yes
4.51375	49.6	74.0	24.4	38.0	32.3	25.8	5.1	150	Vert.	Yes
5.41650	48.7	74.0	25.3	34.5	33.8	25.4	5.8	150	Hor.	Yes
Measurement uncertainty							+2.2 dB / -3.6 dB			

##### Result measured with the average detector:

Frequency GHz	Corr. Value dBµV/m	Limit dBµV/m	Margin dB	Readings dBµV	Antenna factor 1/m	Preamp dB	Cable loss dB	Height cm	Pol.	Restr. Band
1.22958	30.4	54.0	23.6	29.3	24.9	26.5	2.7	150	Hor.	Yes
1.80550	33.5	109.9	76.4	30.5	26.5	26.5	3.0	150	Vert.	No
2.70825	43.9	54.0	10.1	37.6	28.7	26.4	4.0	150	Hor.	Yes
3.61100	42.6	54.0	11.4	32.9	31.3	26.2	4.6	150	Vert.	Yes
4.51375	40.9	54.0	13.1	29.3	32.3	25.8	5.1	150	Vert.	Yes
5.41650	36.2	54.0	17.8	22.0	33.8	25.4	5.8	150	Hor.	Yes
Measurement uncertainty							+2.2 dB / -3.6 dB			

**Transmitter operates at the middle of the assigned frequency band (operation mode 2)**

**Result measured with the peak detector:**

Frequency GHz	Corr. Value dB $\mu$ V/m	Limit dB $\mu$ V/m	Margin dB	Readings dB $\mu$ V	Antenna factor 1/m	Preamp dB	Cable loss dB	Height cm	Pol.	Restr. Band
1.01000	33.7	74.0	40.3	33.7	24.1	26.5	2.4	150	Vert.	Yes
1.22958	38.9	74.0	35.1	37.8	24.9	26.5	2.7	150	Vert.	Yes
1.82950	39.1	106.7	67.6	35.6	26.7	26.5	3.3	150	Vert.	No
2.74425	43.3	74.0	30.7	36.7	28.9	26.4	4.1	150	Hor.	Yes
3.65900	48.3	74.0	25.7	38.5	31.5	26.2	4.5	150	Hor.	Yes
4.57375	47.9	74.0	26.1	36.2	32.4	25.8	5.1	150	Vert.	Yes
14.63600	46.9	106.7	59.8	37.3	33.7	26.6	2.5	100	Hor.	No
Measurement uncertainty							+2.2 dB / -3.6 dB			

**Result measured with the average detector:**

Frequency GHz	Corr. Value dB $\mu$ V/m	Limit dB $\mu$ V/m	Margin dB	Readings dB $\mu$ V	Antenna factor 1/m	Preamp dB	Cable loss dB	Height cm	Pol.	Restr. Band
1.01000	20.9	54.0	33.1	20.9	24.1	26.5	2.4	150	Vert.	Yes
1.22958	30.4	54.0	23.6	29.3	24.9	26.5	2.7	150	Vert.	Yes
1.82950	30.3	106.7	76.4	26.8	26.7	26.5	3.3	150	Vert.	No
2.74425	35.0	54.0	19.0	28.4	28.9	26.4	4.1	150	Hor.	Yes
3.65900	42.2	54.0	11.8	32.4	31.5	26.2	4.5	150	Hor.	Yes
4.57375	38.2	54.0	15.8	26.5	32.4	25.8	5.1	150	Vert.	Yes
14.63600	37.1	106.7	69.6	27.5	33.7	26.6	2.5	150	Hor.	No
Measurement uncertainty							+2.2 dB / -3.6 dB			

**Transmitter operates at the upper end of the assigned frequency band (operation mode 3)**

**Result measured with the peak detector:**

Frequency GHz	Corr. Value dB $\mu$ V/m	Limit dB $\mu$ V/m	Margin dB	Readings dB $\mu$ V	Antenna factor 1/m	Preamp dB	Cable loss dB	Height cm	Pol.	Restr. Band
1.02330	39.7	74.0	34.3	39.7	24.1	26.5	2.4	150	Hor.	Yes
1.25280	37.9	108.0	70.1	36.8	24.9	26.5	2.7	150	Hor.	No
1.85450	43.2	108.0	64.8	39.1	27.0	26.5	3.6	150	Vert.	No
2.78175	43.9	74.0	30.1	37.2	29.0	26.4	4.1	150	Hor.	Yes
3.70900	49.4	74.0	24.6	39.2	31.8	26.2	4.6	150	Vert.	Yes
4.63625	46.2	74.0	27.8	34.4	32.4	25.8	5.2	150	Vert.	Yes
7.41800	53.5	74.0	20.5	34.9	36.3	24.5	6.8	150	Vert.	Yes
Measurement uncertainty							+2.2 dB / -3.6 dB			

**Result measured with the average detector:**

Frequency GHz	Corr. Value dB $\mu$ V/m	Limit dB $\mu$ V/m	Margin dB	Readings dB $\mu$ V	Antenna factor 1/m	Preamp dB	Cable loss dB	Height cm	Pol.	Restr. Band
1.02330	33.4	54.0	20.6	33.4	24.1	26.5	2.4	150	Hor.	Yes
1.25280	30.9	108.0	77.1	29.8	24.9	26.5	2.7	150	Hor.	No
1.85450	37.0	108.0	71.0	32.9	27.0	26.5	3.6	150	Vert.	No
2.78175	36.4	54.0	17.6	29.7	29.0	26.4	4.1	150	Hor.	Yes
3.70900	44.3	54.0	9.7	34.1	31.8	26.2	4.6	150	Vert.	Yes
4.63625	36.5	54.0	17.5	24.7	32.4	25.8	5.2	150	Vert.	Yes
7.41800	43.8	54.0	10.2	25.2	36.3	24.5	6.8	150	Vert.	Yes
Measurement uncertainty							+2.2 dB / -3.6 dB			

Test: Passed

**TEST EQUIPMENT USED FOR THE TEST:**

29, 31 - 34, 36, 44, 45, 49, 73, 75, 146, 159, 165

## 4.7 Conducted emissions on power supply lines (150 kHz to 30 MHz)

### 4.7.1 Method of measurement

This test will be carried out in a shielded chamber. Tabletop devices will set up on a non-conducting support with a size of 1 m by 1.5 m and a height of 80 cm above the ground plane. Floor-standing devices will be placed directly on the ground plane. The set up of the Equipment under test will be in accordance to ANSI C63.4-2009 [1].

The frequency range 150 kHz to 30 MHz will be measured with an EMI Receiver set to MAX Hold mode with peak and average detector and a resolution bandwidth of 9 kHz. A scan will be carried out on the phase (or plus pole in case of DC powered devices) of the AC mains network. If levels detected 10 dB below the appropriate limit, this emission will be measured with the average and quasi-peak detector on all lines.

Frequency range	Resolution bandwidth
150 kHz to 30 MHz	9 kHz

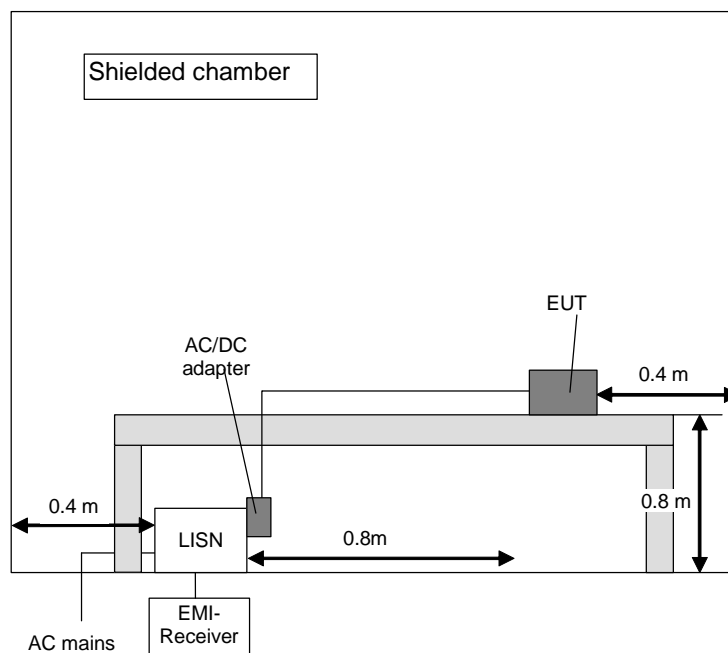

#### 4.7.2 Test results (conducted emissions on power supply lines)

Ambient temperature	21 °C	Relative humidity	25 %
---------------------	-------	-------------------	------

Position of EUT: The EUT was set-up on a non-conducting table of a height of 0.8 m.

Cable guide: The cables of the EUT were fixed on the non-conducting table. For further information of the cable guide refer to the pictures in annex A of this test report.

Test record: All results are shown in the following. This test was carried out in

Supply voltage: During all measurements the EUT was supplied with 12.0 V DC by an AC / DC adaptor type FW3288, which was supplied by 120 V AC / 60 Hz.

The curves in the diagram only represent for each frequency point the maximum measured value of all preliminary measurements, which were made for each power supply line. The top measured curve represents the peak measurement and the bottom measured curve the average measurement.

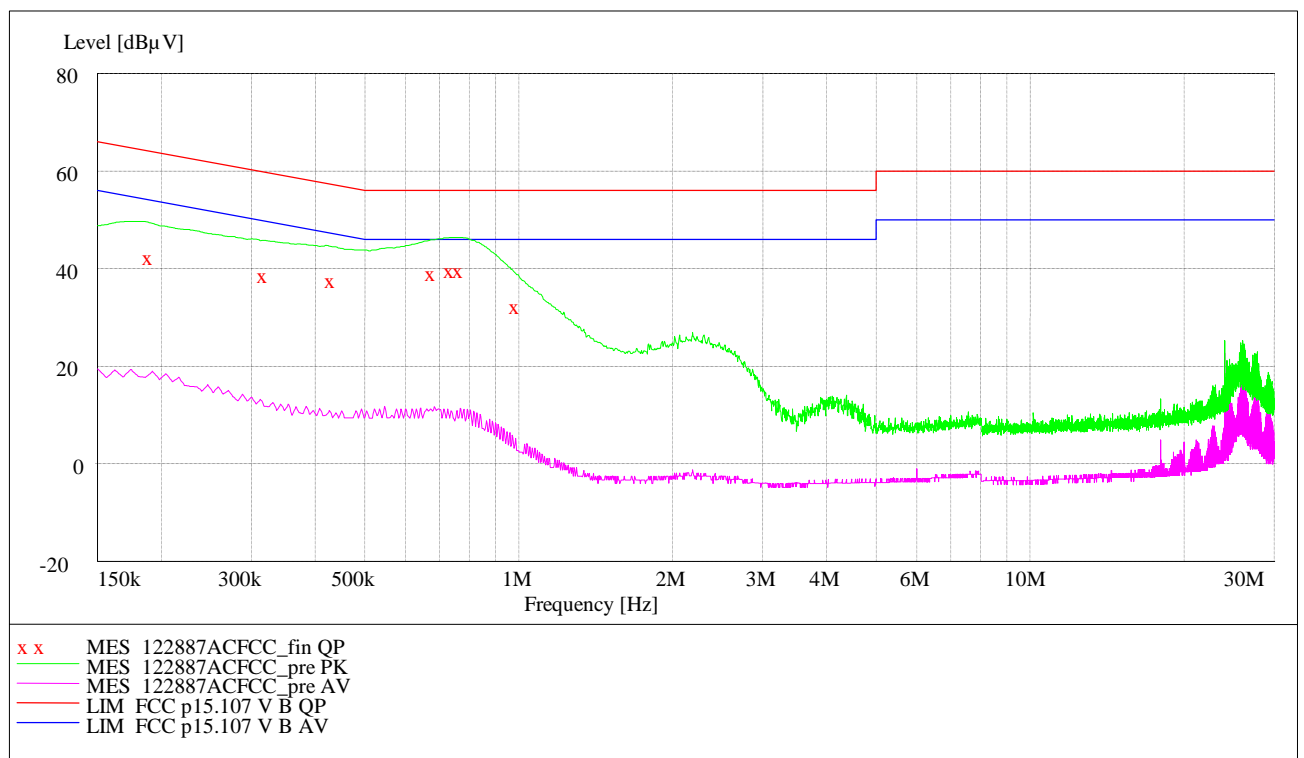

Data record name: 122887ACFCC

Result measured with the quasipeak detector (marked in the diagram by an x):

Frequency MHz	Level dB $\mu$ V	Transducer dB	Limit dB $\mu$ V	Margin dB	Line	PE
0.190500	42.8	1.1	64.0	21.2	L1	GND
0.319200	39.2	0.9	59.7	20.5	L1	FLO
0.431700	38.1	0.9	57.2	19.2	L1	FLO
0.679200	39.5	0.8	56.0	16.5	L1	FLO
0.738600	40.1	0.8	56.0	15.9	L1	FLO
0.769200	40.3	0.8	56.0	15.7	L1	GND
0.989700	32.7	0.7	56.0	23.3	L1	FLO

Test: Passed

TEST EQUIPMENT USED FOR THE TEST:
-----------------------------------

1 - 4, 20
-----------

## 5 TEST EQUIPMENT AND ANCILLARIES USED FOR TESTS

No.	Test equipment	Type	Manufacturer	Serial No.	PM. No.	Cal. Date	Cal. due
1	Shielded chamber M47	-	Albatross Projects	B83117-C6439-T262 -	480662	Weekly verification (system cal.)	
2	EMI Receiver	ESIB 26	Rohde & Schwarz	1088.7490	481182	03/09/2012	03/2014
3	LISN	NSLK8128	Schwarzbeck	8128161	480138	12/20/2012	12/2013
4	High pass filter	HR 0.13- 5ENN	FSY Microwave Inc.	DC 0109 SN 002	480340	Weekly verification (system cal.)	
14	Open area test site	-	Phoenix Test-Lab	-	480085	Weekly verification (system cal.)	
15	EMI Receiver	ESIB 26	Rohde & Schwarz	1088.7490	481182	03/09/2012	03/2014
16	Controller	HD100	Deisel	100/670	480139	-	-
17	Turntable	DS420HE	Deisel	420/620/80	480087	-	-
18	Antenna support	AS615P	Deisel	615/310	480086	-	-
19	Antenna	CBL6111 D	Chase	25761	480894		
20	EMI Software	ES-K1	Rohde & Schwarz	-	480111	-	-
29	Fully anechoic chamber M20	-	Albatross Projects	B83107-E2439-T232	480303	Weekly verification (system cal.)	
31	Measuring receiver	ESI 40	Rohde & Schwarz	100064	480355	02/13/2012	02/2014
32	Controller	MCU	Maturo	MCU/043/971107	480832	-	-
33	Turntable	DS420HE	Deisel	420/620/80	480315	-	-
34	Antenna support	AS615P	Deisel	615/310	480187	-	-
35	Antenna	CBL6112 B	Chase	2688	480328	04/21/2011	04/2014
36	Antenna	3115 B	EMCO	9609-4922	480184	09/28/2011	09/2014
146	Standard Gain Horn 11.9 GHz – 18 GHz	18240-20	Flann Microwave	483	480294	Six month verification (system cal.)	
149	Standard Gain Horn 17.9 GHz – 26.7 GHz	20240-20	Flann Microwave	410	480296	Six month verification (system cal.)	
150	Standard Gain Horn 26.4 GHz – 40.1 GHz	22240-20	Flann Microwave	469	480299	Six month verification (system cal.)	
43	RF-cable No. 36	Sucoflex 106B	Suhner	0522/6B	480571	Weekly verification (system cal.)	
44	RF-cable No. 3	Sucoflex 106B	Suhner	0563/6B	480670	Weekly verification (system cal.)	
45	RF-cable No. 40	Sucoflex 106B	Suhner	0708/6B	481330	Weekly verification (system cal.)	
165	RF-cable 1m	KPS-1533- 400-KPS	Insulated Wire	-	480300	Six month verification (system cal.)	
49	Preamplifier	JS3- 00101200- 23-5A	Miteq	681851	480337	Six month verification (system cal.)	
159	Preamplifier	JS3- 12001800- 16-5A	Miteq	571667	480343	06/28/2012	06/2013
160	Preamplifier	JS3- 18002600- 20-5A	Miteq	658697	480342	06/28/2012	06/2013



No.	Test equipment	Type	Manufacturer	Serial No.	PM. No.	Cal. Date	Cal. due
161	Preamplifier	JS3-26004000-25-5A	Miteq	563593	480344	06/28/2012	06/2013
55	Loop antenna	HFH2-Z2	Rohde & Schwarz	832609/014	480059	02/16/2012	02/2014
73	High Pass Filter	WHJS1000C 11/60EF	Wainwright Instruments GmbH	1	480413	Weekly verification (system cal.)	
75	High Pass Filter	WHKX4.0/18 G-8SS	Wainwright Instruments GmbH	1	480587	Weekly verification (system cal.)	
83	Tuneable Notch Filter	WRCA800/90 0-0.2/40-6EEK	Wainwright Instruments GmbH	15	480414	Weekly verification (system cal.)	

## 6 REPORT HISTORY

Report Number	Date	Comment
F122887E3	25 February 2013	Document created

## 7 LIST OF ANNEXES

ANNEX A TEST SETUP PHOTOGRAPHS 8 pages

122887\_16.JPG: TSU200, test set-up fully anechoic chamber  
 122887\_17.JPG: TSU200, test set-up fully anechoic chamber  
 122887\_15.JPG: TSU200, test set-up fully anechoic chamber  
 122887\_21.JPG: TSU200, test set-up fully anechoic chamber  
 122887\_19.JPG: TSU200, test set-up fully anechoic chamber  
 122887\_20.JPG: TSU200, test set-up fully anechoic chamber  
 122887\_18.JPG: TSU200, test set-up open area test site  
 122887\_22.JPG: TSU200, test set-up shielded chamber

ANNEX B EXTERNAL PHOTOGRAPHS 3 pages

122887\_l.JPG: TSU200, 3-D-view 1  
 122887\_m.JPG: TSU200, 3-D.view 2  
 122887\_n.JPG: TSU200, type plate

ANNEX C INTERNAL PHOTOGRAPHS 8 pages

122887\_o.JPG: TSU200, internal view 1 (cover removed)  
 122887\_p.JPG: TSU200, internal view 2 (antenna removed)  
 122887\_q.JPG: TSU200, main PCB, top view  
 122887\_r.JPG: TSU200, main PCB, bottom view  
 122887\_s.JPG: TSU200, coupler PCB, top view  
 122887\_t.JPG: TSU200, coupler PCB, bottom view  
 122887\_v.JPG: TSU200, antenna PCB, top view  
 122887\_u.JPG: TSU200, antenna PCB, top view