

SOFTWARE HOUSE®

*Multi-Technology
Reader with Indala® Support
(SWH-4130)*

**Version A6
Part Number UM-234
August 2009**



CONTENTS

Introduction	3
Features	5
Mounting	6
Installation Considerations.....	7
Wiring	9
Installation Notes	10
Configuration Notes.....	11
Flash Upgrade Notes	12
Troubleshooting	13
Model SWH-4130 Technical Specifications	15
FCC Digital Device Limitations	17
Canadian Radio Emissions Requirements	18
CE Marking	19

INTRODUCTION

The SWH-4130 is a unique, single reader solution for simultaneously reading HID® proximity cards, Indala® proximity cards, and multiple types of 13.56 MHz smart cards. The triple receiver design allows the reader to cycle between three frequencies to read HID proximity, Indala proximity, and smart cards without perceptible delay.

The reading capability of smart cards includes MIFARE® serial numbers and encrypted MIFARE programmed sectors.

For a complete list of compatible cards and formats for SWH-4130, refer to Table 1, Table , and Table 3.

TABLE 1. HID Proximity Formats

HID Proximity Formats	As shipped Default Mode ON ✓
Standard 26 Bit Wiegand	✓
HID Corporate 1000 (35 bit)	✓
36 Bit Wiegand	✓
SWH 37 Bit Wiegand	✓
Other HID pass through formats	✓

TABLE 2. Indala Proximity Formats

Indala Proximity Formats	As shipped Default Mode ON ✓
Standard 26 Bit Wiegand	
SWH 37 Bit Wiegand	
ACC 37 Bit Wiegand	✓
NOTE: Only one Indala format may be activated in the reader at one time.	

TABLE 3. 13.56 MHz Technologies and Formats

13.56 Technologies and Formats	As shipped Default Mode ON ✓
MiFARE Sector with Read Key	
MiFARE / ISO 14443A Serial Number (32 bit)	✓
ISO 14443B Serial Number (32 bit)	✓
ISO 15693 Serial Number (64 bit)	✓
DESFire Serial Number (56 bit)	✓
iCLASS Serial Number (64 bit)	✓

FEATURES

- Universal compatibility with 125 KHz HID and Indala Proximity cards, ISO 14443A/B and ISO 15693 credentials, and MIFARE encrypted sectors.
- Electrical protection (reverse polarity diode protection on power lines).
- Data lines: high-speed transient voltage suppressor diodes.
- IP65-rated sealed electronics for deployment in both interior and exterior environments.
- Integrated reader tamper protection.
- Ability to flash new firmware into the reader via local RS-485 connection.

MOUNTING

1. Mount the single-gang backplate (with tamper magnet installed) onto the wall.
2. Mount the reader module directly to the backplate and then snap the front cover in place.

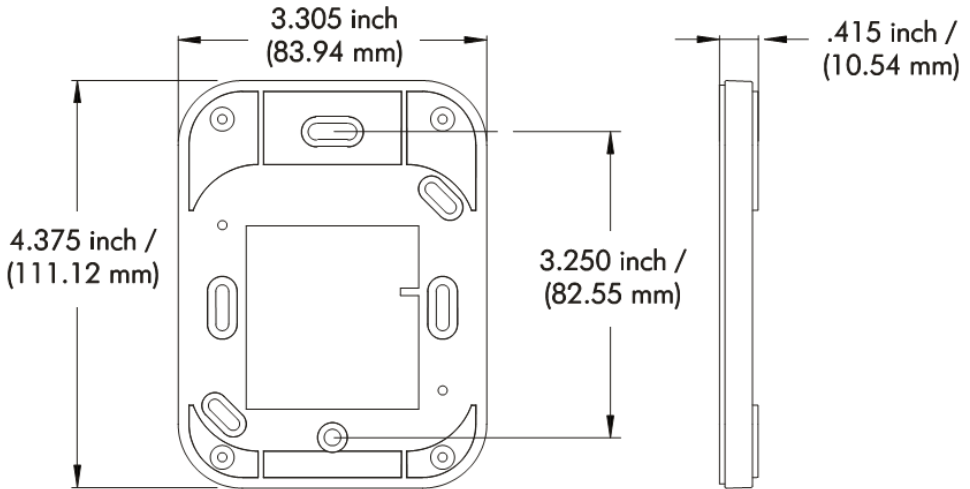
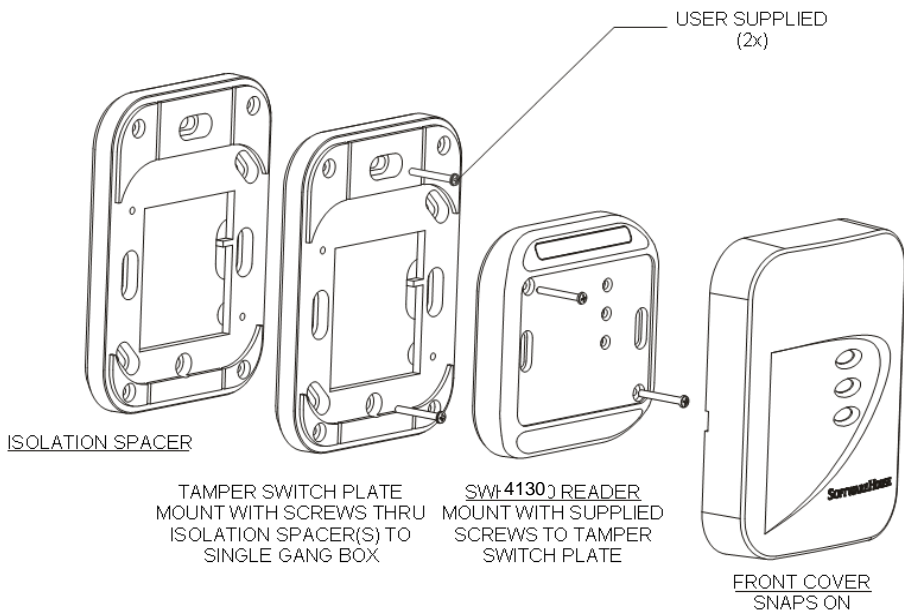

FIGURE 1. Model SWH-4130 Reader Backplate
(includes tamper switch magnet)

NOTE

Mounting holes fit standard U.S. single-width electrical box and standard European (EMEA) electrical box hole patterns.



**FIGURE 2. Mounting Assembly
(including one optional isolation spacer)**

INSTALLATION CONSIDERATIONS

An isolation spacer may be used to improve the read range distance when mounting the reader to a metal surface. The isolation spacer is available from Software House in black (Part number: SWH-SPACER-BLK) or light grey (Part number: SWH-SPACER-LGR).

To optimize reader range, use the number of backplates as indicated in Figure 2. Use of Isolation Spacers is optional and not required for non-metal mounting surfaces.

TABLE 4. Isolation spacer recommendation for mounting the SWH-4130 reader on metal

Distance to Metal	Reading Distance
No metal plate	100%
4.5 cm	100%
2.7 cm (3 tamper plates)	85%
1.8 cm (2 tamper plates)	70%
0.9 cm (1 tamper plate)	50%
0 cm	10%

Installing two SWH-4130 readers side-by-side and back-to-back

Read range is not affected if the center-to-center distance between two readers is greater than or equal to four (4) inches (101.6 mm). Two readers can simultaneously read the same badge or tag if the distance between the two readers is less than 4 inches, center-to-center. If the distance between the two readers is less than four inches, field interference between the two readers may result in a double-badge read.

NOTE

If two readers are being placed back-to-back on a wall less than 4 inches thick, maximum performance can be achieved by using a metal separation plate and then using isolation spacers as necessary.

WIRING

SWH-4130 models have twelve terminals, as noted in Table 5. The terminal strip is removable for easy installation and wiring. When attaching wires to the connector, strip off only the minimum insulation required (approx. 1/8") and push the wire into the connector until the insulation is flush or inside the connector body. This is particularly critical for outdoor readers. While the reader itself is designed and protected to IP65 standards, the cable wires can potentially corrode and short together if not carefully mounted and tightly fastened in the connector body.

TABLE 5. Connector Pins for Model SWH-4130

Pin	Description	Pin	Description
1	External Beeper Control	7	External Green LED Control
2	Ground	8	External Red LED Control
3	Power (9.4 to 16 VDC)	9	A - RS485 - used for Flash upgrade
4	D1 Wiegand	10	B - RS485 - used for Flash upgrade
5	D0 Wiegand	11	Tamper (Normally Closed)
6	Reserved for Future Use	12	Tamper (Normally Closed)

Table 6 indicates maximum wiring distances per Wiegand standard with the three most common gauges of cable.

TABLE 6. Maximum cable distance for 18, 20, or 22 AWG wire

Wire Gauge	18 AWG	20AWG	22 AWG
Cable Distance	500 feet (152 meters)	300 feet (91 meters)	200 feet (61 meters)

INSTALLATION NOTES

Unless otherwise specified in this manual, please follow these guidelines:

1. Shielded cable is recommended in electrically noisy environments.
2. You can use a local power supply for the reader. If so, do not connect the power supply from the controller to the reader. The ground line of the local power supply must be connected to the power supply of the controller.
3. The unit needs to be operated with a power source with limited power consumption according to EN 60950-1 (2003) paragraph 2.5.

Das Gerät ist mit einer Stromquelle mit begrenzter Leistung nach EN 60950-1 (2003) Absatz 2.5 zu betreiben.

4. Use of a pull-up resistor may be required by some controllers. Consult your controller manual.
5. For tamper wiring, connect Pins 11 and 12 to a normally closed supervised input, as shown in Figure 3 for a standard SWH supervised input.

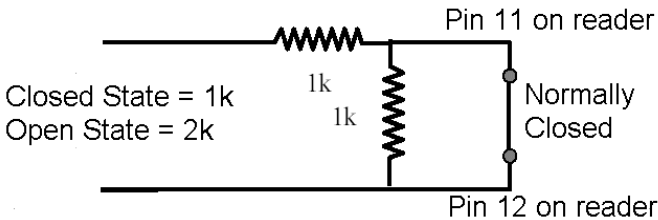

FIGURE 3. Normally Closed Wiring for Reader Tamper

CONFIGURATION NOTES

The default reader settings are shown in Table 1. To change these settings requires the use of special program cards that are available from the Software House Applications Department. Program cards are used to set a specific MIFARE read key, or to change the Indala card format and other settings.

To program a card reader, follow these steps:

1. Power cycle the reader. You will hear a single short beep.
2. Present the *.INI* card. The reader's amber LED turns off to indicate the reader is ready for the first program card.
3. Present the first program card. The reader will respond with 5 beeps and the red and green LEDs alternately flash, and then the amber LED turns on solid.
4. If there are more program cards, repeat steps 2 and 3 until you have presented the necessary number of program cards.
5. The reader is now configured for the specified option(s) and is ready for use.

For more information about programming a card reader, refer to the PDF document entitled *SWH Readers Program Card Use* posted on the Software House Member Center.

FLASH UPGRADE NOTES

In some cases the reader may require a new firmware revision to enable new features or card formats that are not included in a previous revision.

To upgrade the reader, you need to obtain the new firmware file from Software House, and then connect to the reader through a local RS485 connection, using terminals 9 and 10.

In most cases you can use a RS485-to-USB device, or a RS232-to-RS485 converter to connect the PC to the reader. Once a physical connection is established, double-click on the firmware update utility, which is a self-running executable. A typical flash upgrade takes about 2 minutes per reader.

For more information about upgrading the firmware revision, refer to the PDF document entitled *SWH Readers Download Firmware to Reader* posted on the Software House Member Center.

TROUBLESHOOTING

If the operation of a component is in doubt, substitute a known good component and retry the system. Always verify wiring against the provided wiring information before powering up the reader.

TABLE 7. Error Conditions and Possible Solutions

Condition	Possible Solutions
None of the LEDs are on.	Check the following: <ul style="list-style-type: none">■ Power connections to the reader.■ Reader supply voltage at connector pin 3 and that the ground connection pin 2 is secure and well connected.
The door does not open and the green LED does not light when a qualified credential is presented.	Verify that the door strike and the green LED are wired correctly. Verify that the access credential has been entered and that the reader has been properly configured in the host system.
The green LED does not light but the door strike unlocks the door when a valid credential is presented.	Verify that the door strike is wired correctly. Refer to the appropriate wiring diagram in your controller manual. Disconnect the wire from pin 7 (green LED) and connect pin 7 to pin 2 (ground). If the green LED is now on, the reader is good and the connection to the reader is defective. If the green LED does not light, replace the reader.

TABLE 7. Error Conditions and Possible Solutions

Condition	Possible Solutions
The reader does not read a desired card technology, for example, Mifare Sector.	The reader may not be properly configured. If a card technology is desired that is not turned on by default, program cards must be used to configure the reader.

MODEL SWH-4130 TECHNICAL SPECIFICATIONS

Cable Recommendations:	4 core (minimum), shielded, 22 AWG (minimum) cable.
Connectors:	12 position, 3.5 mm Screw Terminals - Plug-In
Certifications:	FCC Part 15, CE.
Open Standards Compliance:	ISO 14443A ISO 14443B (Depending on specific implementation) ISO 15693 (including some partially compliant credentials)
Standard Colors:	Black and Grey.
Dimensions with backplate (height/width/depth):	4.37" × 3.31" × 1.10" (110.99 × 84.07 × 27.94 mm)
Power Supply	Rated Voltage: 9.4 to 16 VDC 150 mA maximum current
Humidity:	5 to 90% (non-condensing)
Operating Temperature:	-31° F to 151° F (-35° C to 67° C)
Index of Protection:	IP 65 (IEC 529)

Software House
70 Westview Street
Lexington, MA 02421
<http://www.swhouse.com>
Fax: 781-466-9550 Phone: 781-466-6660

<p>Read Range:</p>	<p>1 to 4 inches depending on credential technology and environment.</p> <p>Note: Read range for credentials of identical technologies may vary greatly depending on the tuning and antenna structure of each individual credential.</p>
<p>Standard Wiegand Output including:</p>	<p>ID Pass-Through Option</p> <p>Serial Number Read</p> <p>Fixed Wiegand bit stream option</p> <p>SmartFrame[®] encrypted MIFARE Sector read and conversion to Wiegand. Consult your Software House representative for available reconfiguration cards for your reader.</p>
<p>Upgrade</p>	<p>Complete upgrade capability using RS485 port for reflashing of internal ROM.</p>

FCC DIGITAL DEVICE LIMITATIONS

Radio and Television Interference

This equipment has been tested and found to comply with the limits for a Class A digital device, pursuant to Part 15 of the FCC Rules. These limits are designed to provide reasonable protection against harmful interference when the equipment is operated in a commercial environment. This equipment generates, uses, and can radiate radio frequency energy and, if not installed and used in accordance with the instruction manual, may cause harmful interference to radio communications. Operation of this equipment in a residential area is likely to cause harmful interference, in which case the user will be required to correct the interference at his own expense.

This device complies with Part 15 of the FCC rules. Operation is subject to the following two conditions: (1) This device may not cause harmful interference, and (2) this device must accept any interference received, including interference that may cause undesired operation.

In order to maintain compliance with FCC regulations, shielded cables must be used with this equipment. Operation with non-approved equipment or unshielded cables is likely to result in interference to radio and television reception.

CAUTION: Changes or modifications not expressly approved by Software House for compliance could void the user's authority to operate this equipment.

CANADIAN RADIO EMISSIONS REQUIREMENTS

This Class A digital apparatus complies with Canadian ICES-003.

Cet appareil numérique de la classe A est conforme à la norme NMB-003 du Canada.

CE MARKING

Hereby, Software House declares that this equipment, if used according to the instructions, is in compliance with the essential requirements and other relevant provisions of the RTTE Directive 1999/5/EC. For use in all countries of the EU.

A Declaration of Conformity exists for the SWH-4130 Software House Multi-technology readers. To obtain a copy, contact Software House and request the *Declaration of Conformity* document for Multi-technology readers.

Software House
70 Westview Street
Lexington, MA 02421 U.S.A.

In case of alteration of the product, not agreed to by us, this declaration will lose its validity.

This symbol indicates proof of conformity to applicable European Economic Community Council directives and harmonized standards published in the official journal of the European Communities.



Copyrights and Trademarks

This document contains proprietary information of Tyco International Ltd. and is furnished to its customers solely to assist in the installation, testing, operation and maintenance of the equipment described. This document may not be reproduced in whole or in part without the written approval of Tyco International Ltd.

Multi-Technology Reader with Indala[®] Support (SWH-4130)

Version: A6

Part Number: UM-234

August 2009

Copyright ©2009 by Tyco International Ltd. and its respective companies.

All rights reserved.

Product specifications and availability subject to change without notice. Certain product names mentioned herein may be trade names and/or registered trademarks of other companies.