

SOFTWARE HOUSE *Model SWH-5100*

*Proximity 125 KHz Credential
Reader Installation Guide*

**Version A2
Part Number UM-091
February 2005**



CONTENTS

Introduction	3
Features	4
Mounting	5
Installation Considerations.....	6
Wiring	8
Installation Notes	9
Troubleshooting	10
Model SWH-5100 Technical Specifications	11
FCC Digital Device Limitations	13
UL Standards Compliance	14
CE Marking	15

INTRODUCTION

The SWH-5100 Proximity single-gang reader will read a variety of prox cards at a frequency of 125 kHz. Compatible standards include HID and Diester Prox SmartFrame®. Refer to Table 1 for a complete list of compatible standards and data.

TABLE 1. Compatible Credential Formats - Model SWH-5100

HID® 26 Bit
HID® Corporate 1000
HID® 36 Bit Wiegand
HID® 37 Bit Wiegand
Other HID pass through formats
Diester Prox SmartFrame®
CASI-RUSCO® Prox Lite
Others - Future Expansion

FEATURES

- Universal compatibility with most 125 kHz Prox (including all HID® Prox formats)
- Electrical protection (reverse polarity diode protection on power lines)
- Data lines: high-speed transient voltage suppressor diodes
- IP65-rated sealed electronics for deployment in both interior and exterior environments
- Integrated reader tamper protection

MOUNTING

Mount the single-gang backplate (with tamper magnet installed) onto the wall.

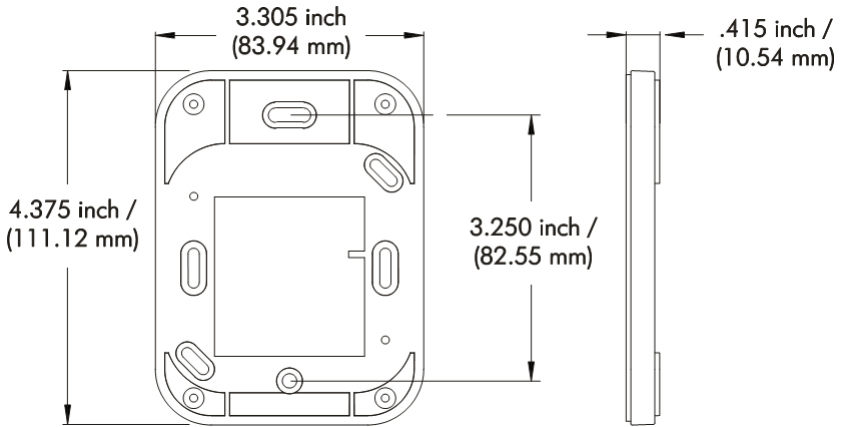

FIGURE 1. Model SWH-5100 Reader Backplate
(includes tamper switch magnet)

NOTE

Mounting holes fit standard U.S. single-width electrical box and standard European (EMEA) electrical box hole patterns.

Mount the reader module directly to the backplate and then snap the front cover in place as indicated in Figure 2.

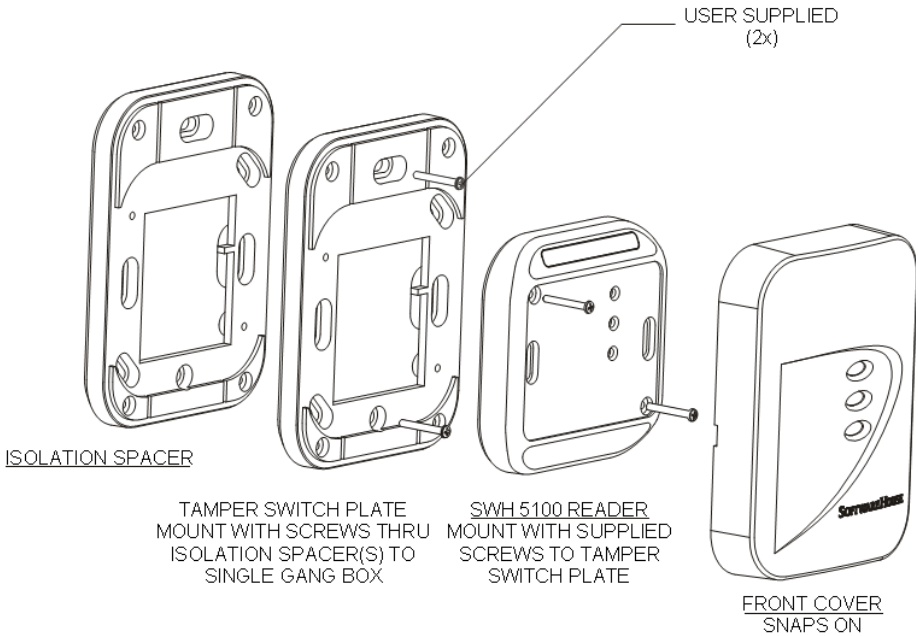

FIGURE 2. Mounting Assembly
(including 1 optional isolation spacer)

INSTALLATION CONSIDERATIONS

An isolation spacer (available from Software House, part number SWH-ISOSPC) may be used to improve the read range distance when mounting the reader to a metal surface. To optimize reader range, use the number of backplates as indicated in Table 2. Use of Isolation Spacers is optional and not required for non-metal mounting surfaces.

TABLE 2. Isolation spacer recommendation for mounting the SWH-5100 reader on metal.

Distance	Reading Distance
No metal plate	100%
4.5 cm	100%
2.7 cm (3 tamper plates)	85%
1.8 cm (2 tamper plates)	70%
0.9 cm (1 tamper plate)	50%
0 cm	10%

Installation of two SWH-5100 readers side-by-side and back-to-back

Read range is not affected if the center-to-center distance between two readers is greater than or equal to four (4) inches (101.6 mm). If the distance between the two readers is less than four inches, field interference between the two readers may result in a double-badge read. Two readers can simultaneously read the same badge or tag if the distance between the two readers is less than 4 inches, center-to-center.

NOTE

If two readers are being placed back-to-back on a wall less than 4 inches thick, maximum performance can be achieved by using a metal separation plate and then using isolation spacers as necessary.

WIRING

The Model SWH-5100 has twelve terminals as noted in Table 3. The terminal strip is removable for easy installation and wiring. When attaching wires to the connector, strip off only the minimum insulation required (approx. 1/8") and push the wire into the connector until the insulation is flush or inside the connector body. This is particularly critical for outdoor readers. While the reader itself is designed and protected to IP65 standards, the cable wires can potentially corrode and short together if not carefully mounted and tightly fastened in the connector body.

TABLE 3. Connector Pins for Model SWH-5100

Pin	Description	Pin	Description
1	External Beeper Control	7	External Green LED Control
2	Ground	8	External Red LED Control
3	Power (8 to 16 VDC)	9	Reserved for Future Use
4	D1 Wiegand	10	Reserved for Future Use
5	D0 Wiegand	11	Tamper (Normally Closed)
6	Reserved for Future Use	12	Tamper (Normally Closed)

Table 4 indicates maximum wiring distances per Wiegand standard with the three most common gauges of cable.

TABLE 4. Maximum cable distance for 18, 20, or 22 AWG wire

Wire Gauge	18 AWG	20AWG	22 AWG
Cable Distance	500 feet (152 meters)	300 feet (91 meters)	200 feet (61 meters)

INSTALLATION NOTES

Unless otherwise specified in this manual, please follow these guidelines:

1. Shielded cable is recommended in electrically noisy environments.
2. You can use a local power supply for the reader. If so, don't connect the power supply from the controller to the reader. The ground line of the local power supply must be connected to the power supply of the controller.
3. The unit needs to be operated with a power source with limited power consumption according to EN 60950-1 (2003) paragraph 2.5.

Das Gerät ist mit einer Stromquelle mit begrenzter Leistung nach EN 60950-1 (2003) Absatz 2.5 zu betreiben.

4. Use of a pull-up resistor may be required by some controllers. Consult your controller manual.
5. For tamper wiring, connect Pins 11 and 12 to a normally closed supervised input, as shown in Figure 3.

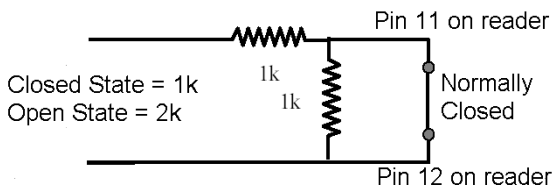

FIGURE 3. Normally Closed Wiring for Reader Tamper

TROUBLESHOOTING

If the operation of a component is in doubt, substitute a known good component and retry the system. Always verify wiring against the provided wiring information before powering up the reader.

TABLE 5. Error Conditions and Possible Solutions

Condition	Possible Solutions
None of the LEDs are on.	Check the following: <ul style="list-style-type: none">■ Power connections to the reader.■ Reader supply voltage at connector pin 3 and that the ground connection pin 2 is secure and well connected.
The door does not open and the green LED does not light when a qualified credential is presented.	Verify that the door strike and the green LED are wired correctly. Verify that the access credential has been entered and that the reader has been properly configured in the host system.
The green LED does not light but the door strike unlocks the door when a valid credential is presented.	Verify that the door strike is wired correctly. Refer to the appropriate wiring diagram in your controller manual. Disconnect the wire from pin 7 (green LED) and connect pin 7 to pin 2 (ground). If the green LED is now on, the reader is good and the connection to the reader is defective. If the green LED does not light, replace the reader.

MODEL SWH-5100 TECHNICAL SPECIFICATIONS

Cable Recommendations:	4 core (minimum), shielded, 22 AWG (minimum) cable.
Connectors:	12 position, 3.5 mm Screw Terminals - Plug-In
Certifications:	FCC Part 15, CE and UL 294 (pending)
Other Standards Compliance:	Deister SmartFrame® in 125 kHz implementations HID® Prox at 125 kHz (All Formats)
Standard Color:	Black (other colors available; contact your Software House representative)
Dimensions with backplate (height/width/depth):	4.37" × 3.31" × 1.10" (110.99 × 84.07 × 27.94 mm)
Power Supply	8-16 VDC 125 mA maximum current @ 12 VDC
Environments:	Meets UL 294 standards for Outdoor Use
Humidity:	5 to 100% (non-condensing)
Operating Temperature:	-31° F to 151° F (-35° to 67° C)

Index of Protection:	IP 65 (IEC 529)
Read Range:	<p>1 to 5 inches depending on credential technology and environment.</p> <p>Note: Read range for credentials of identical technologies may vary greatly depending on the tuning and antenna structure of each individual credential.</p>
Standard Wiegand Output including:	<p>ID Pass-Through Option</p> <p>Fixed Wiegand bit stream option</p> <p>Consult your Software House representative for available reconfiguration cards for your reader.</p>

FCC DIGITAL DEVICE LIMITATIONS

Radio and Television Interference

This equipment has been tested and found to comply with the limits for a digital device, pursuant to Part 15 of the FCC rules. These limits are designed to provide reasonable protection against harmful interference when the equipment is operated in a commercial environment. This equipment generates, uses, and can radiate radio frequency energy and, if not installed and used in accordance with the instruction manual, may cause harmful interference to radio communications. Operation of this equipment in a residential area is likely to cause harmful interference, in which case the user will be required to correct the interference at his own expense.

This device complies with Part 15 of the FCC rules. Operation is subject to the following two conditions: (1) This device may not cause harmful interference, and (2) this device must accept any interference received, including interference that may cause undesired operation.

In order to maintain compliance with FCC regulations, shielded cables must be used with this equipment. Operation with non-approved equipment or unshielded cables is likely to result in interference to radio and television reception.

Caution: Changes or modifications not expressly approved by the manufacturer could void the user's authority to operate this equipment.

CANADIAN RADIO EMISSIONS REQUIREMENTS

This digital apparatus does not exceed the Class A limits for radio noise emissions from digital apparatus set out in the Radio Interference Regulations of the Canadian Department of Communications.

Le present appareil numerique n'emet pas de bruits radioelectriques depassant les limites applicables aux appareils numeriques de la class A prescrites dans le Reglement sur le brouillage radioelectrique edicte par le ministere des Communications du Canada.

UL STANDARDS COMPLIANCE

This reader has been tested by Underwriters Laboratories, Inc. for standard UL 294, Access Control System Units, but has not been tested for compliance with any particular model of controller.

CE MARKING

Hereby, Software House declares that this equipment, if used according to the instructions, is in compliance with the essential requirements and other relevant provisions of the RTTE Directive 1999/5/EC. For use in all countries of the EU.

A Declaration of Conformity exists for the following Software House Multi-technology readers:

SWH-4100	SWH-2100	SWH-1100	SWH-2000
SWH-5100	SWH-4200	SWH-3100	
SWH-1000	SWH-3000	SWH-5000	

To obtain a copy, contact Software House and request the “Declaration of Conformity” document for Multi-technology readers.

Software House
70 Westview Street
Lexington, MA 02421 U.S.A.

In case of alteration of the product, not agreed to by us, this declaration will lose its validity.

This symbol indicates proof of conformity to applicable European Economic Community Council directives and harmonized standards published in the official journal of the European Communities.



Copyrights and Trademarks

This document contains proprietary information of Tyco International, Inc. and is furnished to its customer solely to assist in the installation, testing, operation and maintenance of the equipment described. This document may not be reproduced in whole or in part without the written approval of Tyco International.

Copyright 2005 Tyco International

All rights reserved.

Printed in Germany.

Software House is a trademark of Sensormatic Electronics Corporation.

HID, SmartFrame, and CASI-RUSCO are registered trademarks of other companies not affiliated with Sensormatic.

Software House
70 Westview Street
Lexington, MA 02421
<http://www.swhouse.com>
Fax: 781-466-9550 Phone: 781-466-6660