



Königswinkel 10
32825 Blomberg
Germany
Phone +49 5235 9500-0
Fax +49 5235 9500-10

TEST REPORT

Test Report Reference: R30013 Edition 3

Equipment under Test: Model 245 (PRA5)

Serial Number: -

FCC ID: IXLMODEL245

Applicant: deister electronic GmbH

Manufacturer: deister electronic GmbH

**Test Laboratory
(CAB)
accredited by
DATech e.V.
in compliance with DIN EN ISO/IEC 17025
under the
Reg. No. TTI-P-G071/94-11
and listed by
FCC 31040/SIT1300F2**

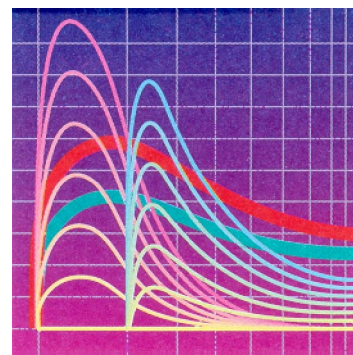

TEST REPORT REFERENCE: R30013 Edition 3

Contents:	Page
1 IDENTIFICATION	3
1.1 APPLICANT.....	3
1.2 MANUFACTURER.....	3
1.3 DATES.....	3
1.4 TEST LABORATORY.....	4
1.5 RESERVATION.....	4
1.6 NORMATIVE REFERENCES.....	4
1.7 TEST RESULTS.....	4
2 TECHNICAL DATA OF EQUIPMENT	5
2.1 DEVICE UNDER TEST	5
2.2 PEREPHERY DEVICES.....	5
3 OPERATIONAL STATES AND PHYSICAL BOUNDARIES	6
4 LIST OF TEST MODULES	7
4.1 EMISSION	7
METHOD OF MEASUREMENT	8
4.2 RADIATED EMISSIONS 9 kHz to 30 MHz.....	8
4.3 RADIATED EMISSIONS 30 MHz to 1 GHz.....	10
4.4 FREQUENCY STABILITY WITH RESPECT TO AMBIENT TEMPERATURE AND SUPPLY VOLTAGE.....	12
5 TEST RESULTS EMISSION TEST	14
5.1 PRELIMINARY RADIATED EMISSION TEST (9 kHz to 30 MHz)	14
5.2 PRELIMINARY RADIATED EMISSION TEST (30 MHz to 1 GHz)	17
5.3 FINAL RADIATED EMISSION TEST (9 kHz to 30 MHz)	20
5.4 FINAL RADIATED EMISSION TEST (30 MHz to 1 GHz).....	21
5.5 OCCUPIED BANDWIDTH.....	23
5.6 FREQUENCY TOLLERANCE	24
6 TEST EQUIPMENT AND ANCILLARIES USED FOR TESTS.....	25
7 LIST OF ANNEXES	29

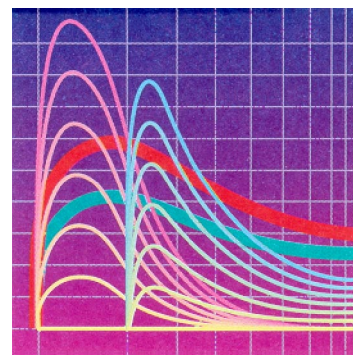

TEST REPORT REFERENCE: R30013 Edition 3

1 IDENTIFICATION

1.1 APPLICANT

Name:	deister electronic GmbH
Address:	Hermann-Bahlsen-Straße 11 – 13 30890 Barsinghausen
Country:	Germany
Name for contact purposes:	Mr. Stefan Eichler
Phone:	+49 51 05 516-129
Fax:	+49 51 05 516-266
Mail address:	eichler@deister-gmbh.de
Applicant represented during the test by the following person:	-

1.2 MANUFACTURER

Name:	deister electronic GmbH
Address:	Hermann-Bahlsen-Straße 11 – 13 30890 Barsinghausen
Country:	Germany
Name for contact purposes:	Mr. Stefan Eichler
Phone:	+49 51 05 516-129
Fax:	+49 51 05 516-266
Mail address:	eichler@deister-gmbh.de
Manufacturer represented during the test by the following person:	-

1.3 DATES

Date of receipt of test sample:	17. January 2003
Start of test:	18. January 2003
End of test:	21. January 2003

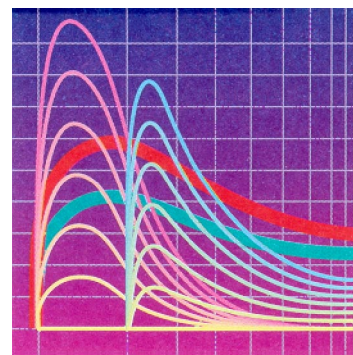



TEST REPORT REFERENCE: R30013 Edition 3

1.4 TEST LABORATORY

The tests were carried out at: **PHOENIX TEST-LAB GmbH**
Königswinkel 10
D-32825 Blomberg Phone: **+49 (0) 52 35 / 95 00-0**
Germany Fax: **+49 (0) 52 35 / 95 00-10**

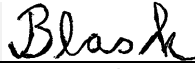
accredited by DATech e.V. in compliance with DIN EN ISO/IEC 17025 under Reg. No. TTI-P-G071/94-11.

Test engineer:	Raimund Blask		07.February. 2003
	name	signature	date
Test report checked:	Bernd Steiner		10.February. 2003
	name	signature	date

Phoenix TEST-LAB GmbH
Königswinkel 10
32825 Blomberg
Tel. 0 52 35 / 95 00-0
Fax 0 52 35 / 95 00-10

stamp

1.5 RESERVATION

This test report is only valid in its original form.

Any reproduction of its contents without written permission of the accredited test laboratory PHOENIX TEST-LAB GmbH is prohibited.

The test results herein refer only to the tested sample. PHOENIX TEST-LAB GmbH is not responsible for any generalisations or conclusions drawn from these test results concerning further samples. Any modification of the tested samples is prohibited and leads to the invalidity of this test report. Each page necessarily contains the PHOENIX TEST-LAB Logo and the TEST REPORT REFERENCE.

1.6 NORMATIVE REFERENCES

[1] **ANSI C63.4-1992** American National Standard for Methods of Measuring of Radio-Noise Emissions from Low-Voltage Electrical and Electronic Equipment in the Range of 9 kHz to 40 GHz.

[2] **FCC 47 CFR Part 15 (July 2002)** Radio Frequency Devices

1.7 TEST RESULTS

The requirements of this test document are fulfilled by the equipment under test. The complete test results are presented in the following.

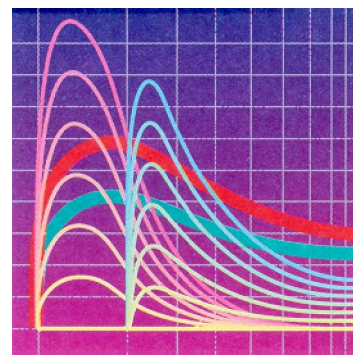

TEST REPORT REFERENCE: R30013 Edition 3

2 TECHNICAL DATA OF EQUIPMENT

2.1 DEVICE UNDER TEST

Type of equipment:	Short range inductive control card reader
Type designation:	Model 245 (PRA59)
Serial No.:	-
FCC ID:	IXLMOEL245
Antenna type:	Integral

The following external I/O cables were used:

Cable	Length	Shielding	Connector
Connection cable to 12 pin wiring plug	2.5 m	Yes	12 pin connector
-	-	-	-
-	-	-	-
-	-	-	-
-	-	-	-

2.2 PEREPHERY DEVICES

The following equipment was used as control unit and ancillary equipment:

- The EUT was connected to an external power supply.

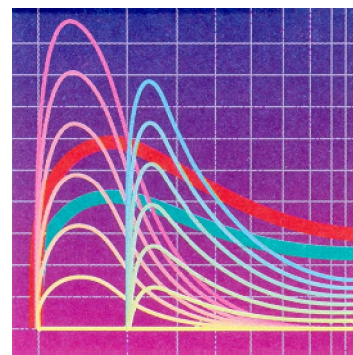

3 OPERATIONAL STATES AND PHYSICAL BOUNDARIES

For all measurements the Model 245 (PRA5) was tested in normal operation mode (transmit-mode without presence of TAG). The tested sample was unsealed and not labeled. The production model will be sealed and the FCC label will be placed on the sealing.

The Model 245 (PRA5) can be supplied with DC voltages in the range 8 V to 30 V. During the preliminary tests it could be shown, that the 8 V DC supply voltage produces the worst case emissions, so the final measurements were carried out with a supply voltage of 8 V DC.

At the start and the end of each test the function of the EUT was checked with the help of a TAG (Mifare card), which was submitted by the applicant. Pretests has shown that the emissions of the reader where higher in case of not reading a TAG. This was the reason for carrying out the tests in unmodulated state (transmit mode).

The PIN 9 and 10 of the 12-pin-connector were not connected during the test, because the applicant declared them for service use only. Additionally the Pin 11 and 12 of the 12-pin-connector were not connected, because they are only connected to a not used reed-contact on the PCB.

During all tests a shielded 4-pair cable was used. Because there is no possibility to connect the shielding to the EUT, the shielding was connected to the system ground of the test site.

For the whole frequency range a preliminary measurement in a fully anechoic chamber with a measuring distance of 3 m was carried out to determine the frequencies, which were radiated by the EUT. The final measurements on the detected frequencies were carried out on an outdoor test site without ground plane (for the frequency range 9 kHz to 30 MHz) and on an open area test site with ground plane (for the frequency range 30 MHz to 1 GHz).

The physical boundaries of the Equipment Under Test are shown below.

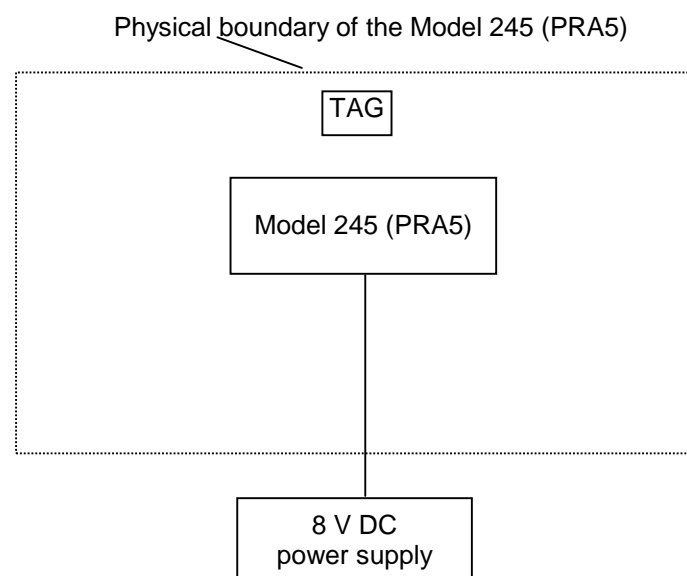

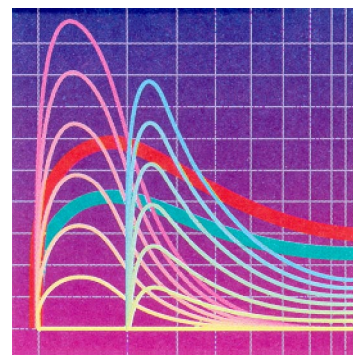

TEST REPORT REFERENCE: R30013 Edition 3

4 LIST OF TEST MODULES

4.1 EMISSION

Radiated emissions FCC 47 CFR Part 15 section 15.209 [2]						
No.	Application	Frequency range	Limits (microvolts/meter)	Reference standard	Remark	Status
1	Intentional radiator	0.009 to 0.49 MHz 0.490 to 1.705 MHz 1.705 to 30.0 MHz 30 to 88 MHz 88 to 216 MHz 216 to 960 MHz 960 to 1000 MHz	2400/f(kHz) at 300 m 24000/f(kHz) at 30 m 30 dB μ V/m at 30 m 40.0 dB μ V/m at 3 m 43.5 dB μ V/m at 3 m 46.0 dB μ V/m at 3 m 54.0 dB μ V/m at 3 m	ANSI C63.4 (1992);	-	Passed
Radiated emissions FCC 47 CFR Part 15 section 15.225 (a)[2]						
No.	Application	Frequency range	Limits (microvolts/meter)	Reference standard	Remark	Status
2	Operation with in the band 13.553 – 13.567 MHz	13.553 to 13.567 MHz	10,000	ANSI C63.4 (1992);	-	Passed
Radiated emissions FCC 47 CFR Part 15 section 15.225 (b)[2]						
No.	Application	Frequency range	Limits (microvolts/meter)	Reference standard	Remark	Status
2	Operation with in the band 13.553 – 13.567 MHz	13.553 to 13.567 MHz	10,000	ANSI C63.4 (1992);	-	Passed
Frequency tolerance over temperature and supply voltage FCC 47 CFR Part 15 section 15.225 (c)[2]						
No.	Application	Limits	Reference standard	Remark	Status	
4	Temperature range -20°C to +50°C and supply voltage 85 to 115 % or new battery	0.01 %	ANSI C63.4 (1992);	-	Passed	

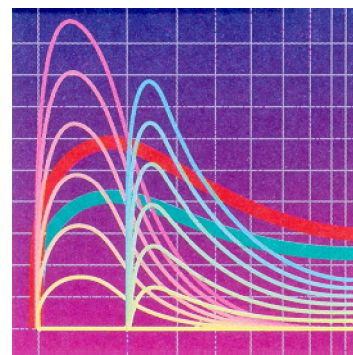

METHOD OF MEASUREMENT

4.2 RADIATED EMISSIONS 9 kHz to 30 MHz

The radiated emission measurement is divided into two stages.

Preliminary measurement:

In the first stage a preliminary measurement will be performed in a shielded room with a measuring distance of 3 meters. Tabletop devices will set up on a non-conducting support with a size of 1 m by 1.5 m and a height of 80 cm. Floor-standing devices will be placed directly on the turntable/ground plane. The set up of the Equipment under test will be in accordance to ANSI C63.4-1992 [1].

The frequency range 9 kHz to 30 MHz will be monitored with a spectrum analyser while the system and its cables will be manipulated to find out the configuration with the maximum emission levels if applicable. The EMI Receiver will be set to MAX Hold mode. The EUT and the measuring antenna will be rotated around their vertical axis to found the maximum emissions.

The resolution bandwidth of the spectrum analyser will be set to the following values:

Frequency range	Resolution bandwidth
9 kHz to 150 kHz	200 Hz
150 kHz to 30 MHz	10 kHz

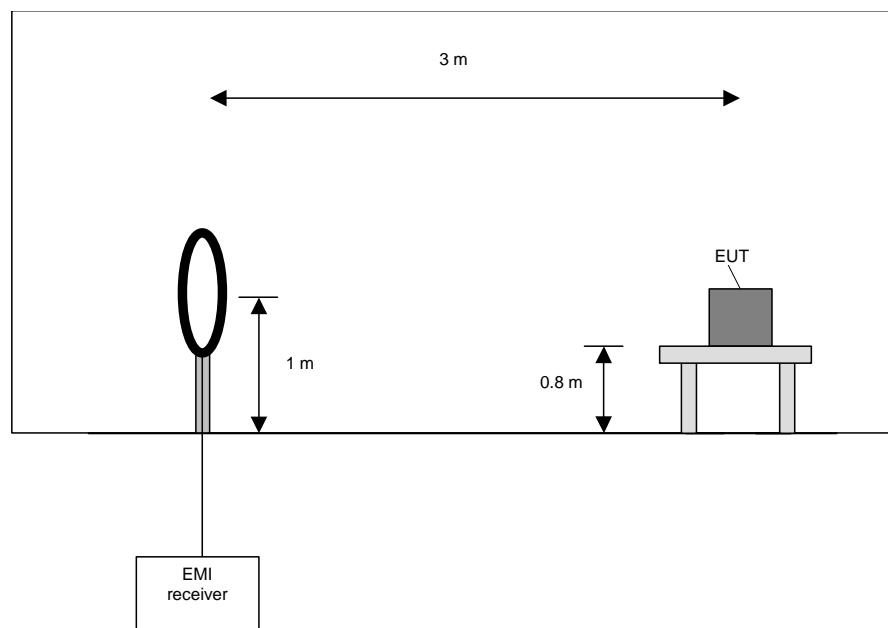

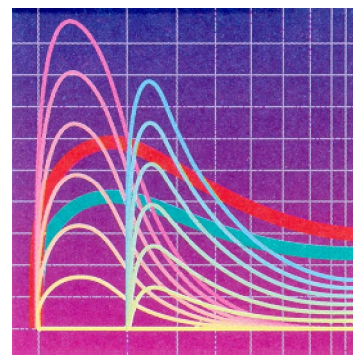

Preliminary measurement procedure:

Prescans were performed in the frequency range 9 kHz to 150 kHz and 150 kHz to 30 MHz.

The following procedure will be used:

- 1) Monitor the frequency range at horizontal polarisation and a EUT azimuth of 0 °.
- 2) Manipulate the system cables within the range to produce the maximum level of emission.
- 3) Rotate the EUT by 360 ° to maximize the detected signals.
- 4) Make a hardcopy of the spectrum.
- 5) Measure the frequencies of highest detected emission with a lower span and resolution bandwidth to increase the accuracy and note the frequency value.
- 6) Repeat steps 1) to 4) with the other orthogonal axes of the EUT if applicable (handheld equipment).
- 7) Rotate the measuring antenna and repeat steps 1) to 5).

Final measurement:

In the second stage a final measurement will be performed on an open area test site with no conducting ground plane in a measuring distances of 3 m, 10 m and 30 m. In the case where larger measuring distances are required the results will be extrapolated based on the values measured on the closer distances according to Section 15.31 (f) (2) [2]. The final measurement will be performed with a EMI Receiver set to Quasi Peak detector except for the frequency bands 9 kHz to 90 kHz and 110 kHz to 490 kHz where an average detector will be used according Section 15.209 (d) [2].

On the during the preliminary measurement detected frequencies the final measurement will be performed while rotating the EUT and the measuring antenna in the range of 0 ° to 360 ° around their vertical axis until the maximum value is found.

The resolution bandwidth of the EMI Receiver will be set to the following values:

Frequency range	Resolution bandwidth
9 kHz to 150 kHz	200 Hz
150 kHz to 30 MHz	9 kHz

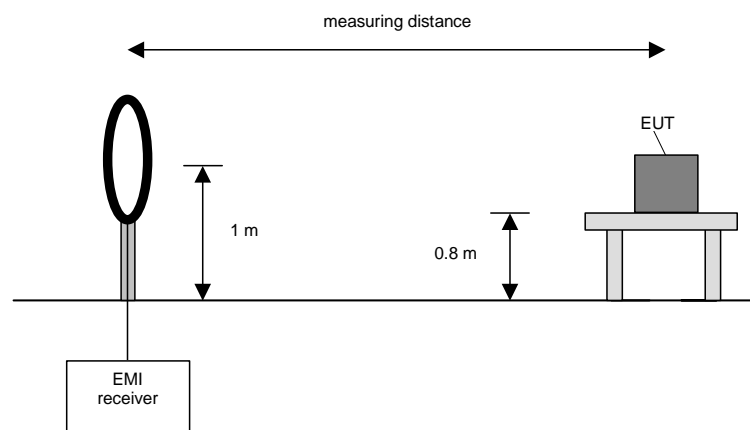

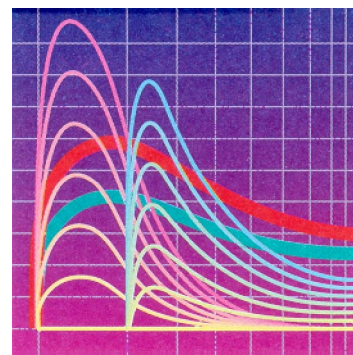

Final measurement procedure:

The following procedure will be used:

- 1) Monitor the frequency range with the measuring antenna at vertical orientation parallel to the EUT at an azimuth of 0 °.
- 2) Rotate the EUT by 360 ° to maximize the detected signals and note the azimuth and orientation.
- 3) Rotate the measuring antenna to find the maximum and note the value.
- 4) Rotate the measuring antenna and repeat steps 1) to 3) until the maximum value is found.
- 5) Repeat steps 1) to 4) with the other orthogonal axes of the EUT if applicable (handheld equipment).

4.3 RADIATED EMISSIONS 30 MHz TO 1 GHz

The radiated emission measurement is divided into two stages.

Preliminary measurement:

In the first stage a preliminary measurement will be performed in a fully anechoic chamber with a measuring distance of 3 meter. Tabletop devices will set up on a non-conducting support with a size of 1 m by 1.5 m and a height of 80 cm. Floor-standing devices will be placed directly on the turntable/ground plane. The set up of the Equipment under test will be in accordance to ANSI C63.4-1992 [1].

The frequency range 30 MHz to 1 GHz will be measured with an EMI Receiver set to MAX Hold mode and a resolution bandwidth of 100 kHz. The measurement will be performed in horizontal and vertical polarisation of the measuring antenna and while rotating the EUT in its vertical axis in the range of 0 ° to 360 °.

The resolution bandwidth of the EMI Receiver will be set to the following values:

Frequency range	Resolution bandwidth
30 MHz to 1 GHz	100 kHz

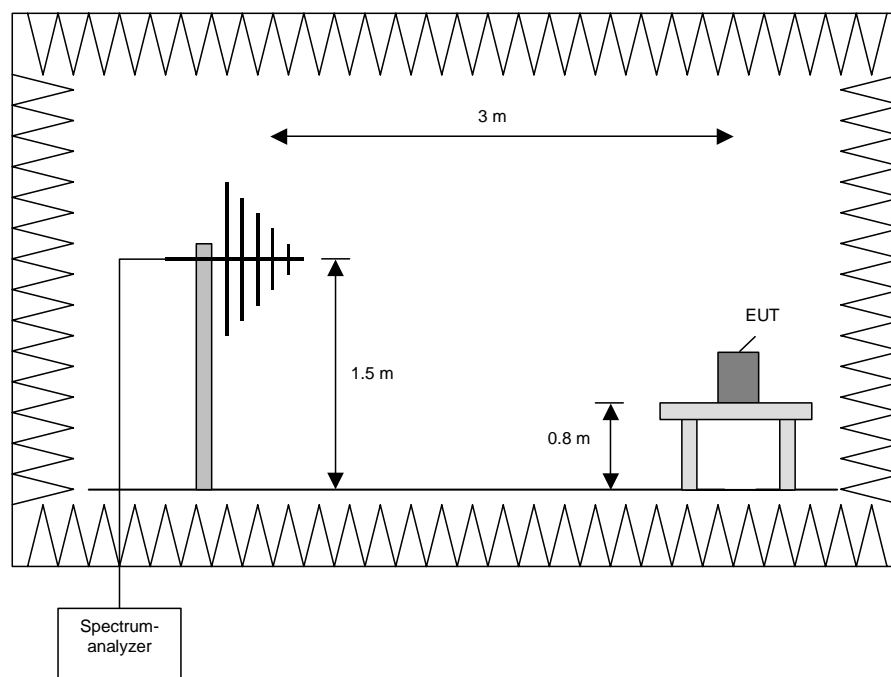

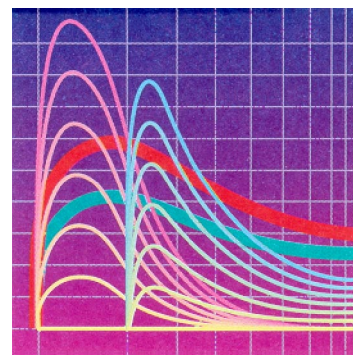

Procedure preliminary measurement:

Prescans were performed in the frequency range 30 MHz to 230 MHz and 230 MHz to 1 GHz. The following procedure will be used:

1. Monitor the frequency range at horizontal polarisation and a EUT azimuth of 0 °
2. Manipulate the system cables within the range to produce the maximum level of emission
3. Rotate the EUT by 360 ° to maximize the detected signals.
4. Make a hardcopy of the spectrum
5. Measure the frequency of 3 highest detected emissions with a lower span and resolution bandwidth to increase the accuracy and note the frequency value.
6. Repeat steps 1) to 4) with the other orthogonal axes of the EUT if handheld equipment
7. Repeat steps 1) to 5) with the vertical polarisation of the measuring antenna.

Final Measurement:

In the second stage a final measurement on an open area test site will be performed on selected frequencies found in the preliminary measurement. During this test the EUT will be rotated in the range of 0 ° to 360 °, the measuring antenna will be set to horizontal and vertical polarisation and raised and lowered in the range from 1 m to 4 m to find the maximum level of emissions.

The resolution bandwidth of the EMI Receiver will be set to the following values:

Frequency range	Resolution bandwidth
30 MHz to 1 GHz	120 kHz

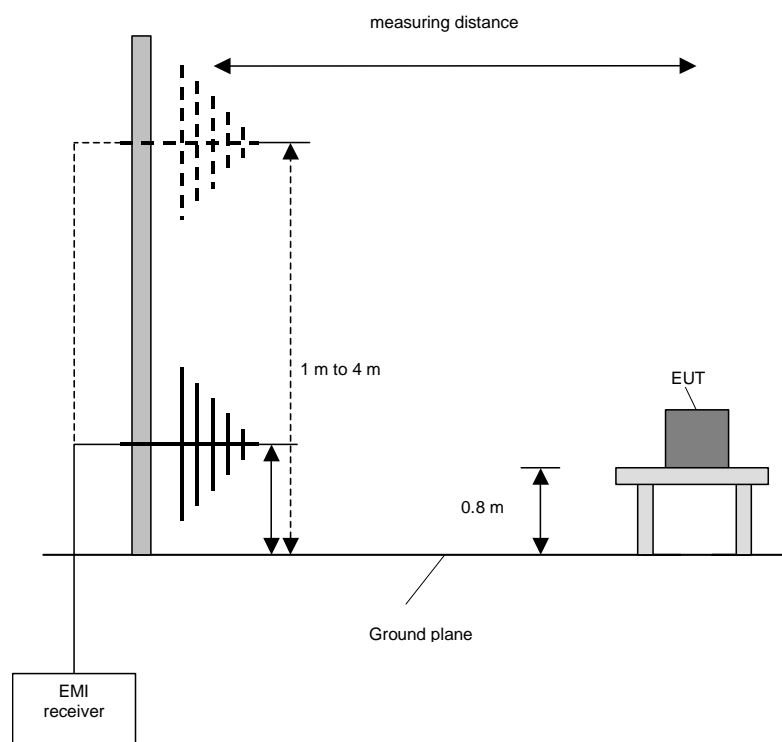

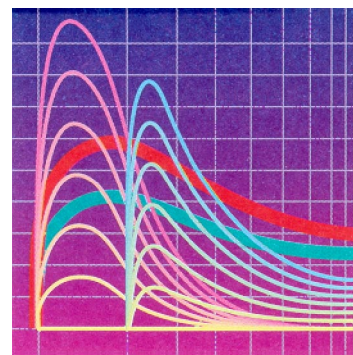

Procedure final measurement:

The following procedure will be used:

- 1) Measure on the selected frequencies at an antenna height of 1 m and a EUT azimuth of 23 °
- 2) Move the antenna from 1 m to 4 m and note the maximum value at each frequency.
- 3) Rotate the EUT by 45 ° and repeat 2) until an azimuth of 337 ° is reached.
- 4) Repeat 1) to 3) for the other orthogonal antenna polarization.
- 5) Move the antenna and the turntable to the position where the maximum value is detected.
- 6) Measure while moving the antenna slowly +/- 1 m
- 7) Set the antenna to the position where the maximum value is found
- 8) Measure while moving the turntable +/- 45 °
- 9) Set the turntable to the azimuth where the maximum value is found
- 10) Measure with Final detector (QP or AV) and note the value
- 11) Repeat 5) to 10) for each frequency
- 12) Repeat 1) to 11) for each orthogonal axes of the EUT if handheld equipment

4.4 FREQUENCY STABILITY WITH RESPECT TO AMBIENT TEMPERATURE AND SUPPLY VOLTAGE

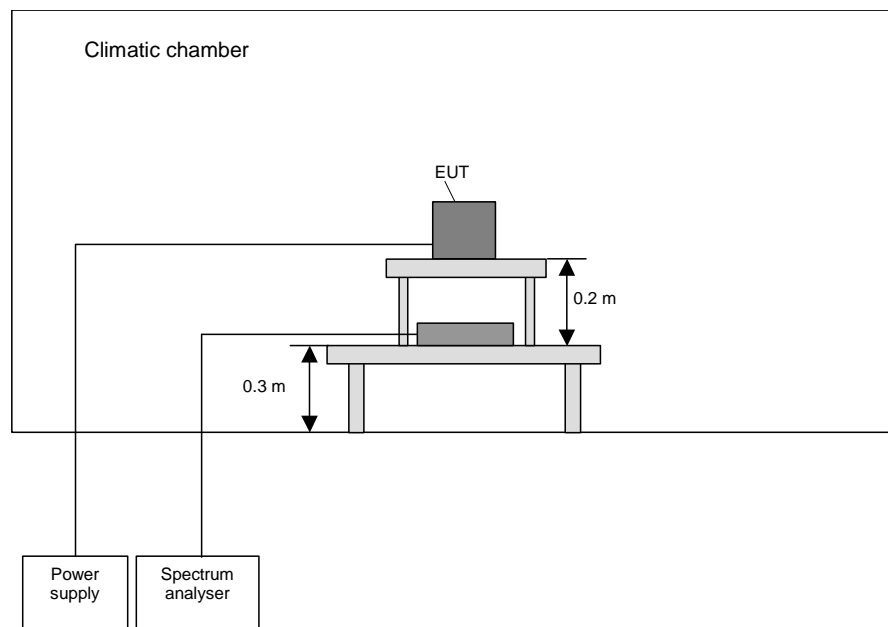

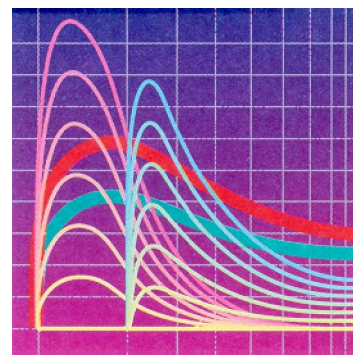

TEST REPORT REFERENCE: R30013 Edition 3

The following procedure will be used:

- 1) Place the EUT in the climatic chamber
- 2) Switch on the EUT and check the correct function and the settings of the spectrum analyser
- 3) Switch off the EUT and tune the climatic chamber to a temperature of 20 °C. Wait until the thermal balance is obtained
- 4) Switch the EUT on and record the frequency at start-up and 2, 5 and 10 minutes after powering on.
- 5) Repeat 4) with 85 % and 115 % of the nominal supply voltage (AC only)
- 6) Switch off the EUT and tune the climatic chamber to a temperature of 50 °C. Wait until the thermal balance is obtained
- 7) Switch the EUT on and record the frequencies at start-up and 2, 5 and 10 minutes after powering on.
- 8) Repeat 7) with 85 % and 115 % of the nominal supply voltage (AC only)
- 9) Switch off the EUT and tune the climatic chamber to a temperature of -20 °C. Wait until the thermal balance is obtained
- 10) Switch the EUT on and record the frequencies at start-up and 2, 5 and 10 minutes after powering on.
- 11) Repeat 10) with 85 % and 115 % of the nominal supply voltage (AC only)

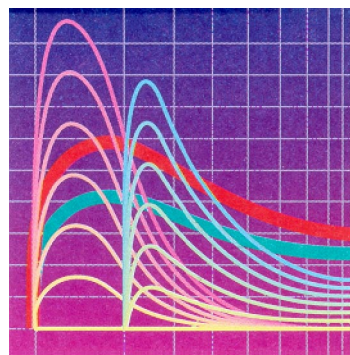

TEST REPORT REFERENCE: R30013 Edition 3

5 TEST RESULTS EMISSION TEST

5.1 PRELIMINARY RADIATED EMISSION TEST (9 kHz TO 30 MHz)

Ambient temperature	20 °C	Relative humidity	65 %
---------------------	-------	-------------------	------

Position of EUT: The EUT was set-up on a wooden table of a height of 0.8 m. The distance between EUT and antenna was 3 m.

Cable guide: The cable of the EUT was fixed on the wooden table. For further information of the cable guide refer to the pictures in annex A of this test report.

Test record: The test was carried out in normal operation mode of the EUT (transmit mode). All results are shown in the following.

30013_1.wmf (9 kHz to 150 kHz):

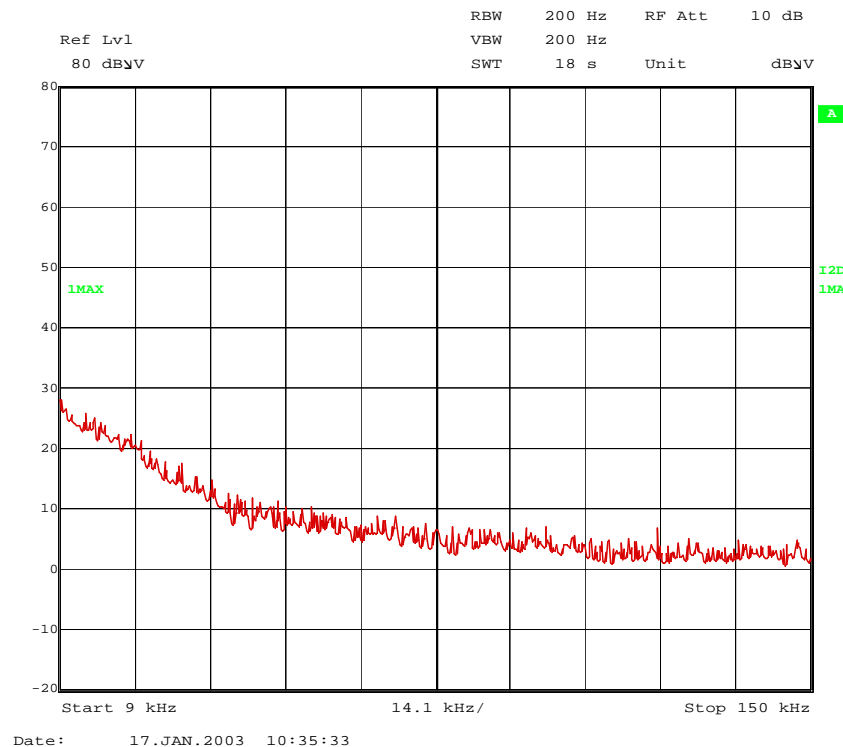

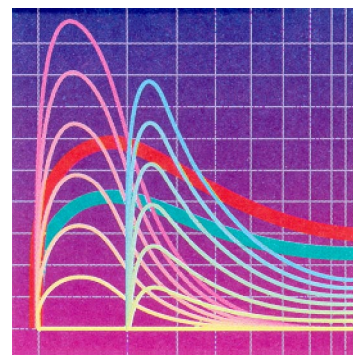

TEST REPORT REFERENCE: R30013 Edition 3

30013_2.wmf (150 kHz to 1 MHz):

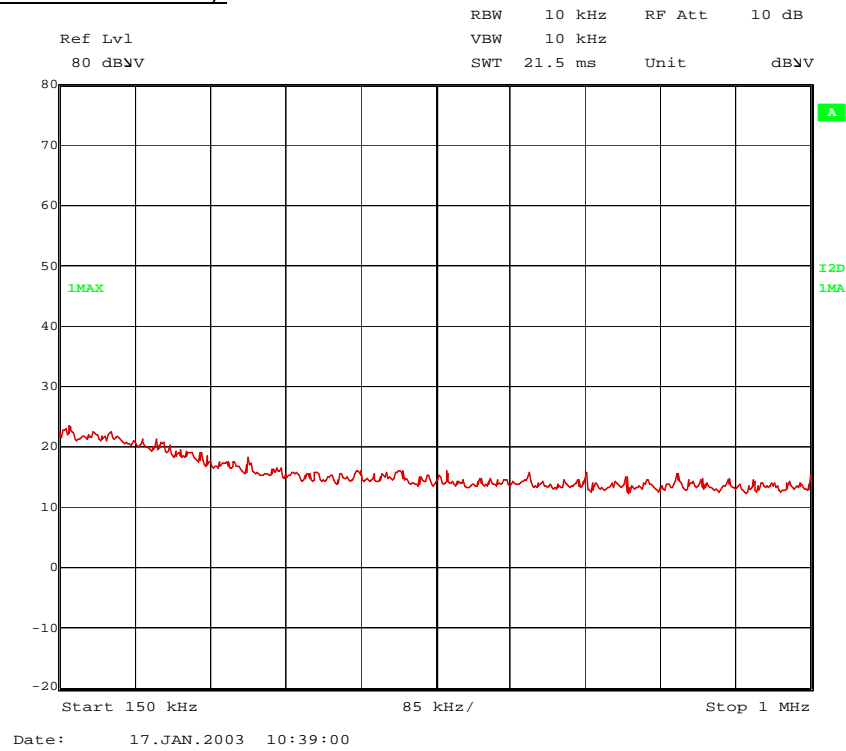

30013_3.wmf (1 MHz to 30 MHz):

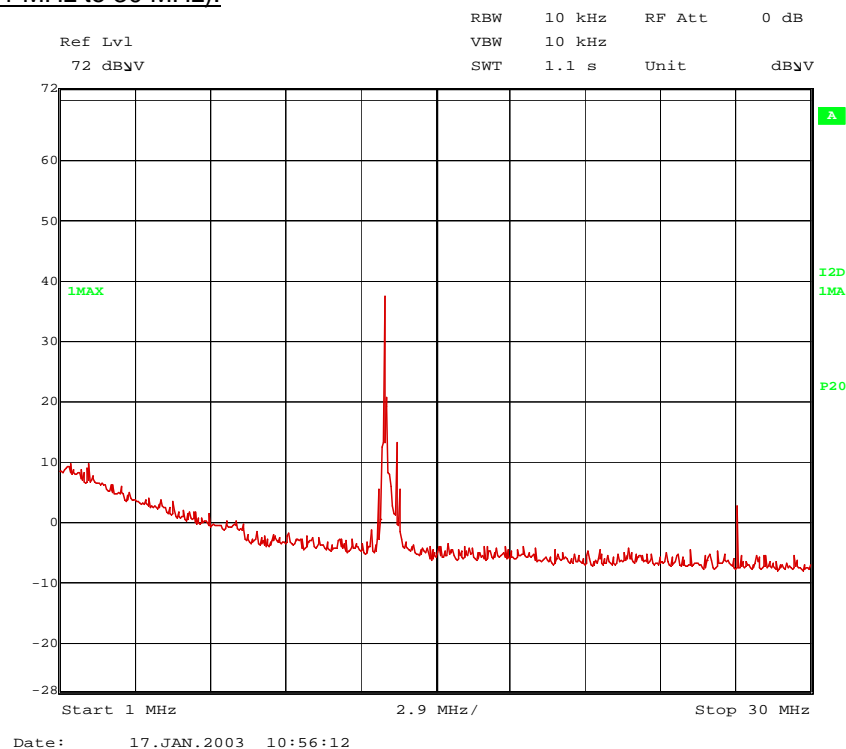

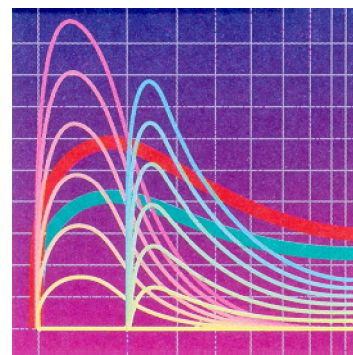

TEST REPORT REFERENCE: R30013 Edition 3

The following significant frequency was found during the preliminary radiated emission test:

- 27.120 MHz

No frequency was found inside the restricted bands according to FFC 47 CFR Part 15 section 15.205 [2].

The following frequency was found inside the 13.533 to 13.567 MHz band according to FFC 47 CFR Part 15 section 15.225 [2].

- 13.560 MHz

These frequencies have to be measured on the outdoor test site. The results of this final measurement are shown in subclause 6.3 of this test report.

TEST EQUIPMENT USED THE TEST:

29, 31 - 33, 41, 42

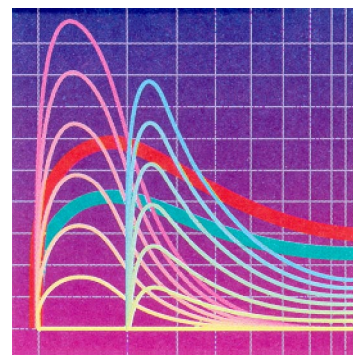

5.2 PRELIMINARY RADIATED EMISSION TEST (30 MHz to 1 GHz)

Ambient temperature	20 °C	Relative humidity	60 %
---------------------	-------	-------------------	------

Position of EUT: The EUT was set-up on a wooden table of a height of 0.8 m. The distance between EUT and antenna was 3 m.

Cable guide: The cable of the EUT was fixed on the wooden table. For further information of the cable guide refer to the pictures in annex A of this test report.

Test record: The test was carried out in normal operation mode of the EUT (transmit mode). All results are shown in the following.

30013_4.wmf (30 MHz to 230 MHz):

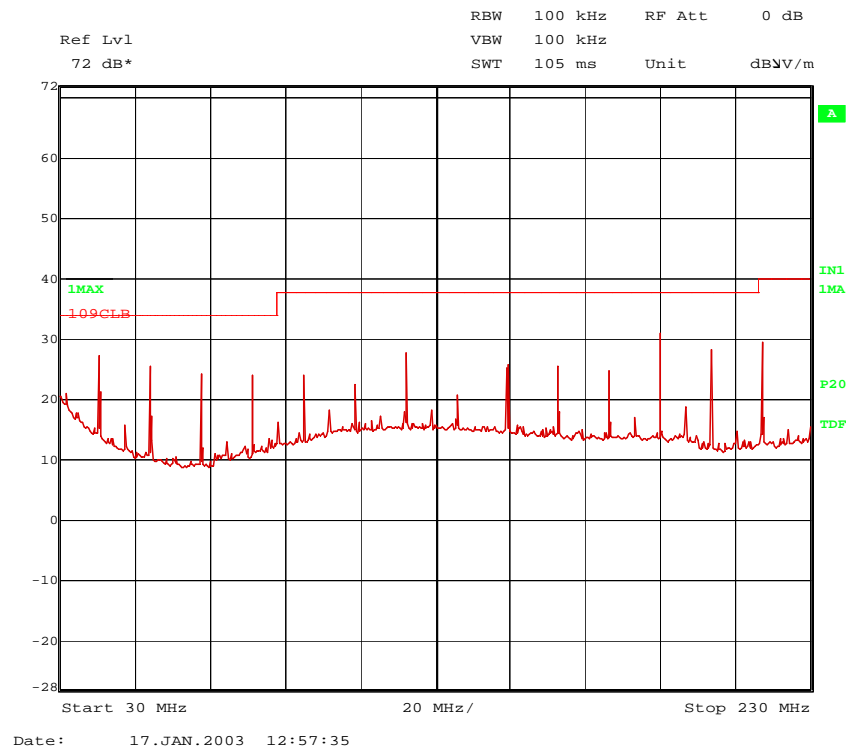

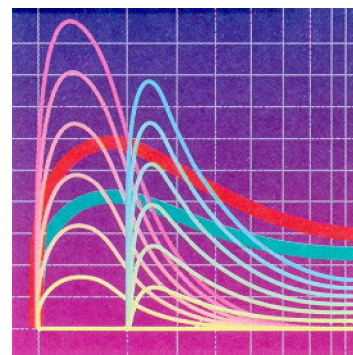

TEST REPORT REFERENCE: R30013 Edition 3

30013_5.wmf (230 MHz to 1 GHz):

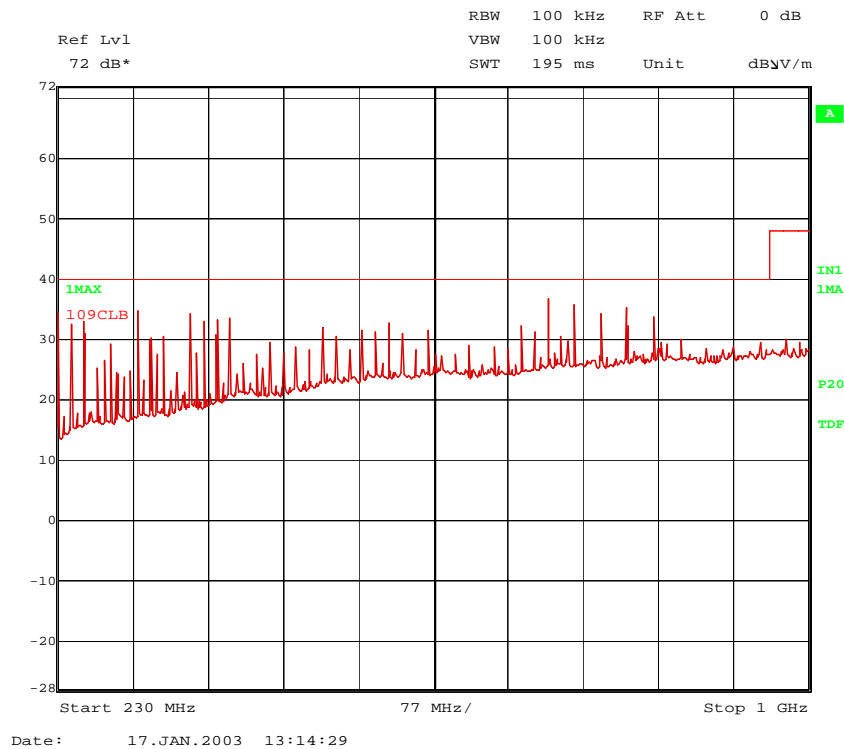

The following significant frequencies were found during the preliminary radiated emission test:

- 40.680 MHz;
- 54.240 MHz;
- 67.800 MHz;
- 81.360 MHz;
- 108.480 MHz;
- 122.040 MHz;
- 149.160 MHz;
- 176.280 MHz;
- 189.840 MHz
- 203.400 MHz
- 298.320 MHz
- 311.880 MHz
- 339.000 MHz
- 366.120 MHz
- 813.600 MHz

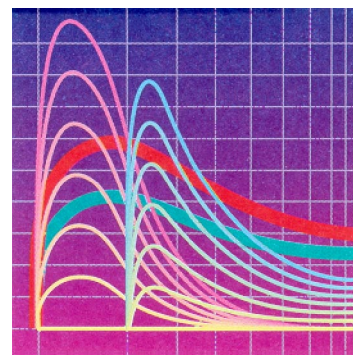

TEST REPORT REFERENCE: R30013 Edition 3

The following frequencies were found inside the restricted bands according to FCC 47 CFR Part 15 section 15.205 [2].

- 135.600 MHz;
- 162.720 MHz;
- 244.078 MHz;
- 257.638 MHz;
- 271.200 MHz;
- 284.760 MHz.

These frequencies have to be measured on the open area test site. The results of this final measurement are shown in subclause 6.4 of this test report.

TEST EQUIPMENT USED FOR THE TEST:

29, 31 – 35, 37, 42

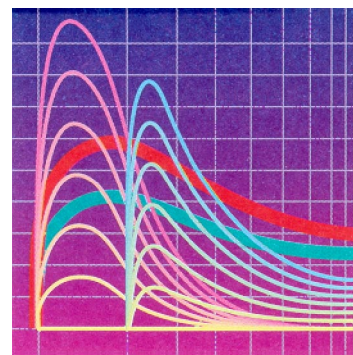

TEST REPORT REFERENCE: R30013 Edition 3

5.3 FINAL RADIATED EMISSION TEST (9 kHz TO 30 MHz)

Ambient temperature	20 °C	Relative humidity	60 %
---------------------	-------	-------------------	------

- Position of EUT:** The EUT was set-up on a wooden table of a height of 0.8 m. The distance between EUT and antenna was 10 m and 30 m.
- Cable guide:** The cable of the EUT was fixed on the wooden table. For further information of the cable guide refer to the pictures in annex A of this test report.
- Test record:** The test was carried out in normal operation mode of the EUT (transmit mode). All results are shown in the following.
- Limits:** To calculate the limits according to the used measuring distance, the 40 dB/decade extrapolation method was used.
- Supply voltage:** For measuring the amplitude of the fundamental frequency (13.560 MHz) the supply voltage was varied from 8 V DC to 30 V DC. There was no changing of the amplitude for these supply voltages measurable. So the EUT was supplied with 8 V DC.

Test results: The test results were calculated with the following formula:

$$\text{Result [dB}\mu\text{V/m]} = \text{reading [dB}\mu\text{V]} + \text{antenna factor [dB/m]}$$

Measuring results (distance 30 m):

Fundamental frequency						
Frequency MHz	Result dB μ V/m	Limit dB μ V/m	Margin dB	Detector	Readings dB μ V	Antenna factor * dB/m
13.560	48.4	80	31.6	QP	28.4	20

*: Cable loss included

Measuring results (distance 10 m):

Highest spurious emissions						
Frequency MHz	Result dB μ V/m	Limit dB μ V/m	Margin dB	Detector	Readings dB μ V	Antenna factor * dB/m
27.120	32.2	50	17.8	QP	12.2	20
Three highest spurious emissions in restricted bands						
Frequency kHz	Result dB μ V/m	Limit dB μ V/m	Margin dB	Detector	Readings dB μ V	Antenna factor * dB/m
No emissions in restricted bands found						

*: Cable loss included

Test: Passed

TEST EQUIPMENT USED FOR THE TEST:

40 - 43

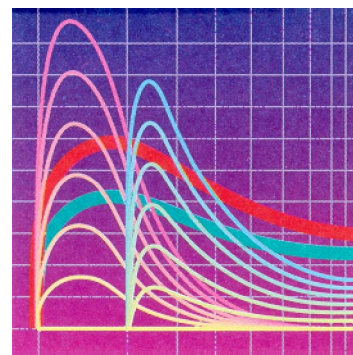

TEST REPORT REFERENCE: R30013 Edition 3

5.4 FINAL RADIATED EMISSION TEST (30 MHz TO 1 GHz)

Ambient temperature	20 °C	Relative humidity	50 %
---------------------	-------	-------------------	------

- Position of EUT:** The EUT was set-up on a wooden table of a height of 0.8 m. The distance between EUT and antenna was 3 m.
- Cable guide:** The cable of the EUT was fixed on the wooden table. For further information of the cable guide refer to the pictures in annex A of this test report.
- Test record:** The test was carried out in normal operation mode of the EUT (transmit mode). All results are shown in the following.
- Supply voltage:** During all measurements the EUT was supplied with 8 V DC.
- Test results:** The test results were calculated with the following formula:

$$\text{Result [dB}\mu\text{V/m]} = \text{reading [dB}\mu\text{V]} + \text{cable loss [dB]} + \text{antenna factor [dB/m]}$$

The measured points and the limit line in the following diagram refer to the standard measurement of the emitted interference in compliance with the above-mentioned standard. The measured points marked with x are the measured results of the standard final measurement on the open area test site.

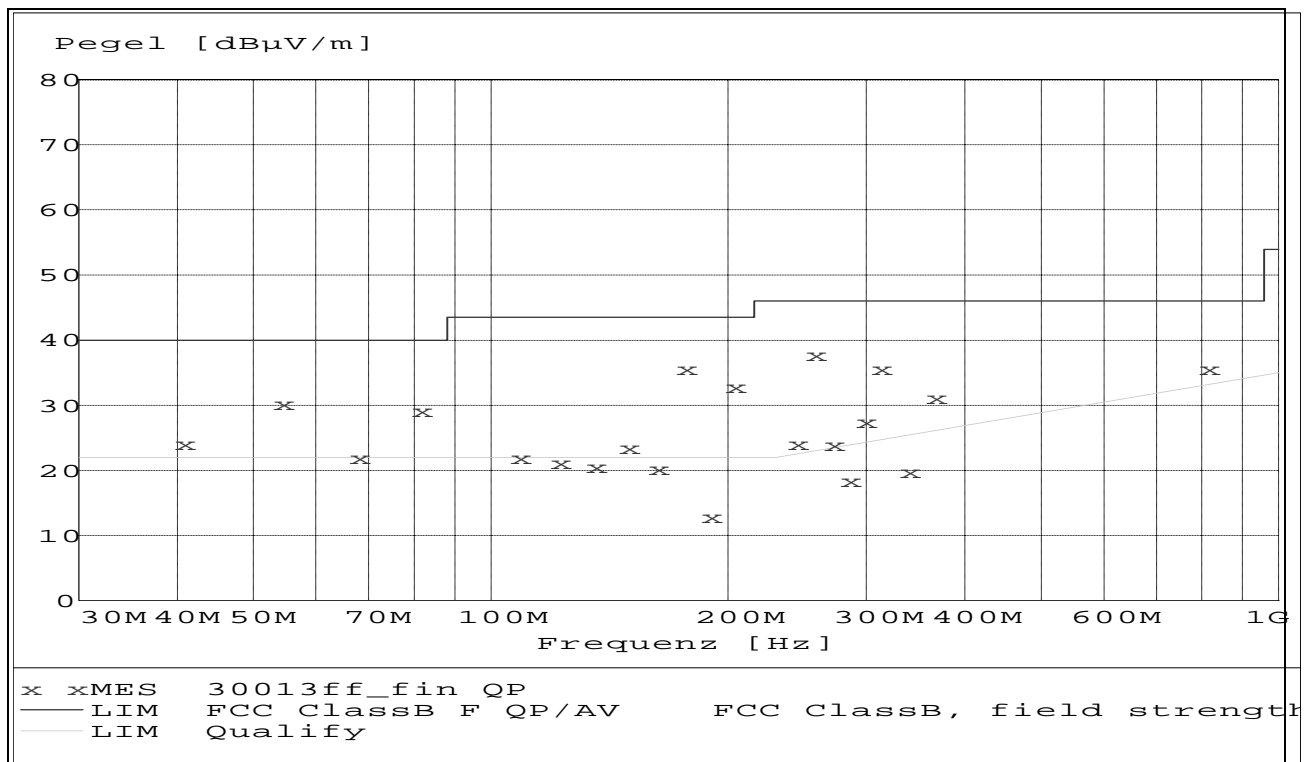

Data record name: 30013ff

of 20.01.03

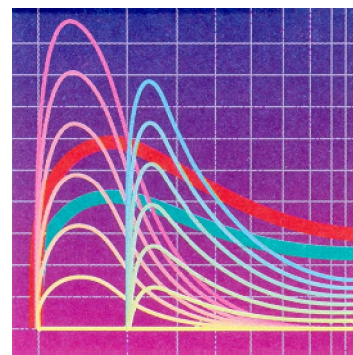

TEST REPORT REFERENCE: R30013 Edition 3

The results of the standard final measurement on the open area test site are indicated in the table below. The limits as well as the measured results (levels) refer to the above-mentioned standard while taking account of the specified requirements for a 3 m measuring distance.

The measurement time with the quasi-peak measuring detector is 1 second.

Result measured with the quasi-peak detector:

Three highest spurious emissions outside restricted bands									
Frequency MHz	Result dBµV/m	Limit dBµV/m	Margin dB	Readings dBµV	Antenna factor 1/m	Cable loss dB	Height cm	Azimuth deg	Pol.
54.240000	30.2	40.0	9.8	22.2	7.0	1.0	258	158	Vert.
67.800000	21.9	40.0	18.1	14.7	6.1	1.1	381	150	Vert.
108.480000	21.9	43.5	21.6	9.2	11.3	1.4	375	319	Hor.
Three highest spurious emissions in restricted bands									
Frequency MHz	Result dBµV/m	Limit dBµV/m	Margin dB	Readings dBµV	Antenna factor 1/m	Cable loss dB	Height cm	Azimuth deg	Pol.
135.600000	20.5	43.5	23.0	7.3	11.7	1.5	171	158	Hor.
162.720000	20.2	43.5	23.3	7.8	10.7	1.7	234	112	Hor.
244.078000	24.1	46.0	21.9	10.7	11.4	2.0	98	247	Vert.
Other spurious emissions outside restricted bands									
Frequency MHz	Result dBµV/m	Limit dBµV/m	Margin dB	Readings dBµV	Antenna factor 1/m	Cable loss dB	Height cm	Azimuth deg	Pol.
40.680000	24.1	40.0	15.9	9.1	14.1	0.9	278	248	Hor.
81.360000	29.2	40.0	10.8	19.9	8.1	1.2	400	247	Vert.
298.320000	27.4	46.0	18.6	12.5	12.7	2.2	100	292	Hor.
311.877000	35.6	46.0	10.4	20.8	12.5	2.3	101	157	Hor.
813.600000	35.6	46.0	10.4	10.7	21.2	3.7	109	0	Vert.
Other spurious emissions inside restricted bands									
Frequency MHz	Result dBµV/m	Limit dBµV/m	Margin dB	Readings dBµV	Antenna factor 1/m	Cable loss dB	Height cm	Azimuth deg	Pol.
257.638000	37.8	46.0	8.2	23.4	12.3	2.1	106	158	Hor.
271.200000	23.9	46.0	22.1	9.7	12.1	2.1	284	100	Vert.
284.760000	18.4	46.0	27.6	3.7	12.5	2.2	325	88	Vert.

The test results were calculated with the following formula:

$$\text{Result [dBµV/m]} = \text{reading [dBµV]} + \text{cable loss [dB]} + \text{antenna factor [dB/m]}$$

Test: Passed

TEST EQUIPMENT USED FOR THE TEST:

14 – 20, 42

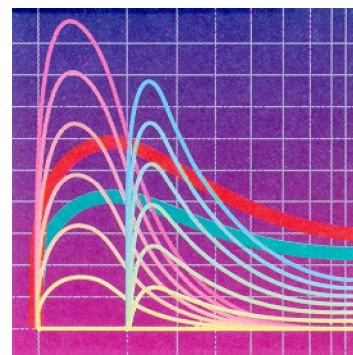

TEST REPORT REFERENCE: R30013 Edition 3

5.5 OCCUPIED BANDWIDTH

Ambient temperature:	20 °C	Relative humidity:	62 %
----------------------	-------	--------------------	------

Test set-up: For this test the test set-up from the preliminary emission measurement test set-up was used.

Cable guide: The cable of the EUT was fixed on the wooden table. For further information of the cable guide refer to the pictures in annex A of this test report.

Supply voltage: For measuring the amplitude of the fundamental frequency (13.560 MHz) the supply voltage was varied from 8 V DC to 30 V DC. There was no changing of the amplitude for these supply voltages measurable. So the EUT was supplied with 8 V DC.

Test record: The test was carried out in continuous transmission mode in the presence of a TAG in front of the EUT.

Calibration: The display of the spectrum analyser was calibrated with a signal generator before.

30013_neu.wmf

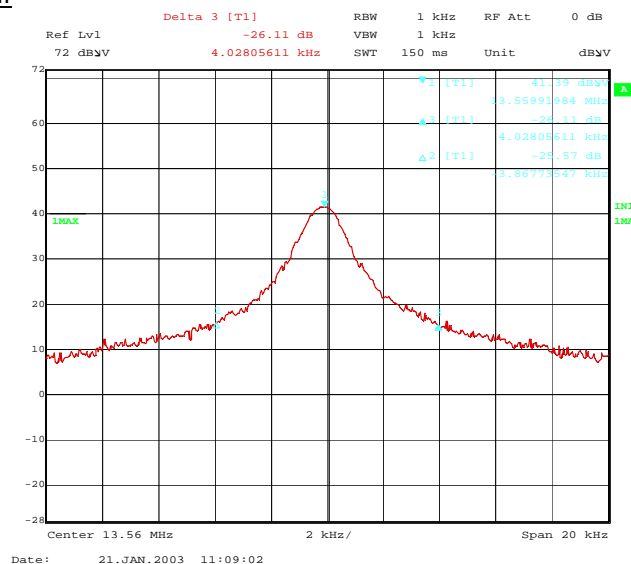

F_L	F_U	BW ($F_U - F_L$)
13.56394 MHz	13.56005 MHz	7.9 kHz

TEST EQUIPMENT USED THE TEST:

29, 31 - 33, 41, 42, 44, 47

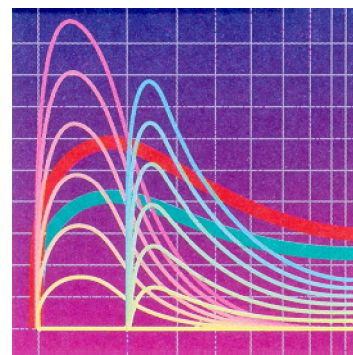

TEST REPORT REFERENCE: R30013 Edition 3

5.6 FREQUENCY TOLLERANCE

Ambient temperature	20 °C	Relative humidity	65 %
---------------------	-------	-------------------	------

Supply voltage: 8 V DC

Temperature:	Minutes after switch on	Frequency:	Allowed tolerance:	Measured tolerance:	Result:
20 ° C	10	13.55981 MHz	-	-	Reference
50 ° C	0	13.55973 MHz	± 1.35 kHz	- 80 Hz	Passed
	2	13.55971 MHz	± 1.35 kHz	- 100 Hz	Passed
	5	13.55970 MHz	± 1.35 kHz	- 110 Hz	Passed
	10	13.55970 MHz	± 1.35 kHz	- 110 Hz	Passed
- 20 ° C	0	13.55991 MHz	± 1.35 kHz	+ 100 Hz	Passed
	2	13.55991 MHz	± 1.35 kHz	+ 100 Hz	Passed
	5	13.55992 MHz	± 1.35 kHz	+ 110 Hz	Passed
	10	13.55992 MHz	± 1.35 kHz	+ 110 Hz	Passed

Supply voltage: 30 V DC

Temperature:	Minutes after switch on	Frequency:	Allowed tolerance:	Measured tolerance:	Result:
20 ° C	10	13.55970 MHz	-	-	Reference
50 ° C	0	13.55974 MHz	± 1.35 kHz	+ 40 Hz	Passed
	2	13.55971 MHz	± 1.35 kHz	+ 10 Hz	Passed
	5	13.55971 MHz	± 1.35 kHz	+ 10 Hz	Passed
	10	13.55970 MHz	± 1.35 kHz	+ 0 Hz	Passed
- 20 ° C	0	13.55991 MHz	± 1.35 kHz	+ 210 Hz	Passed
	2	13.55991 MHz	± 1.35 kHz	+ 210 Hz	Passed
	5	13.55992 MHz	± 1.35 kHz	+ 220 Hz	Passed
	10	13.55992 MHz	± 1.35 kHz	+ 220 Hz	Passed

Test result: Passed

TEST EQUIPMENT USED FOR THE TEST:

31, 42, 45 – 47

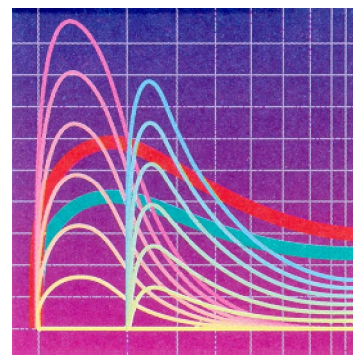

TEST REPORT REFERENCE: R30013 Edition 3

6 TEST EQUIPMENT AND ANCILLARIES USED FOR TESTS

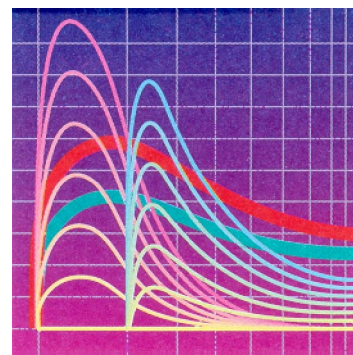

TEST REPORT REFERENCE: R30013 Edition 3

Emission measurement at AC mains and DC in / out ports at M4					
No.	Test equipment	Type	Manufacturer	Serial No.	PM-No
1	Shielded chamber M4	-	Siemens	B83117S1-X158	480088
2	Measuring receiver	ESAI	Rohde & Schwarz	831953/001 833181/018	480025 480026
3	LISN	NSLK8128	Schwarzbeck	8128155	480058
4	DC-filter	B84266-A21-E13	Siemens	940164525	480099
5	AC-filter	B84299-D87-E3	Siemens	930262292	480097
6	EMI-Software	ES-K1	Rohde & Schwarz	-	480111

Radiated emission measurement at M5					
No.	Test equipment	Type	Manufacturer	Serial No.	PM-No
7	Fully anechoic chamber M5	-	Siemens	B83177-S1-X156	480073
8	Measuring receiver	ESVS30	Rohde & Schwarz	829673/012	480024
9	Controller	HD100	Deisel	100/324	480067
10	Antenna support	MA240	Deisel	228/314	480069
11	Turntable	DS412	Deisel	412/317	480070
12	Antenna	CBL6112C	Chase	2689	480327
13	EMI Software	ES-K1	Rohde & Schwarz	-	480111

Radiated emission measurement at M6					
No.	Test equipment	Type	Manufacturer	Serial No.	PM-No
14	Open area test site	-	Phoenix Test-Lab	-	480085
15	Measuring receiver	ESVS30	Rohde & Schwarz	829673/012	480024
16	Controller	HD100	Deisel	100/670	480139
17	Turntable	DS420HE	Deisel	420/620/80	480087
18	Antenna support	AS615P	Deisel	615/310	480086
19	Antenna	CBL6111 A	Chase	1643	480147
20	EMI Software	ES-K1	Rohde & Schwarz	-	480111

Radiated emission measurement at M8					
-------------------------------------	--	--	--	--	--

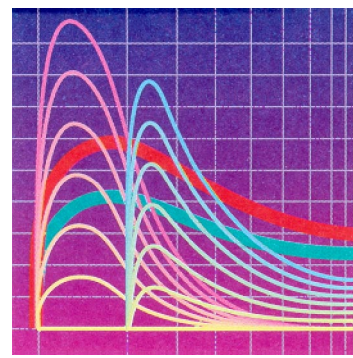

TEST REPORT REFERENCE: R30013 Edition 3

No.	Test equipment	Type	Manufacturer	Serial No.	PM-No
21	Fully anechoic chamber M8	-	Siemens	B83117-E7019-T231	480190
22	Measuring receiver	ESMI	Rohde & Schwarz	843977/001 843530/018	480179 480180
23	Measuring receiver	ESCS 30	Rohde & Schwarz	828985/014	480270
24	Controller	HD100	Deisel	100/427	480181
25	Turntable	DS420	Deisel	420/435/97	480186
26	Antenna support	AS615P	Deisel	615/310	480187
27	Antenna	CBL6112 A	Chase	2034	480185
28	EMI Software	ES-K1	Rohde & Schwarz	-	480111

Radiated emission measurement at M20					
No.	Test equipment	Type	Manufacturer	Serial No.	PM-No
29	Fully anechoic chamber M20	-	Albatross Projects	B83107-E2439-T232	480303
30	Measuring receiver	ESMI	Rohde & Schwarz	843977/001 843530/018	480179 480180
31	Measuring receiver	ESI 40	Rohde & Schwarz	100064	480355
32	Controller	HD100	Deisel	100/670	480326
33	Turntable	DS420HE	Deisel	420/620/80	480315
34	Antenna support	AS615P	Deisel	615/310	480187
35	Antenna	CBL6112 B	Chase	2688	480328
36	Antenna	3115 A	EMCO	9609-4918	480183
37	RF-cable No. 30	RTK 081	Rosenberger	-	410141
38	EMI Software	ES-K1	Rohde & Schwarz	-	480111
39	RF-cable No. 5	RTK 081	Rosenberger		410097

Ancillary equipment used for testing					
No.	Test equipment	Type	Manufacturer	Serial No.	PM-No
40	Outdoor test site	-	Phoenix Test-Lab	-	480293
41	Loop antenna	HFH2-Z2	Rohde & Schwarz	832609/014	480059
No.	Test equipment	Type	Manufacturer	Serial No.	PM-No
42	Power supply	TOE 8852	Toellner	51712	480233

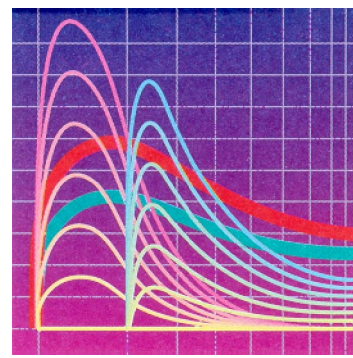

TEST REPORT REFERENCE: R30013 Edition 3

43	EMI test receiver	ESPC	Rohde & Schwarz	843756/006	480150
44	Signal generator	SMHU	Rohde & Schwarz	844170/017	480266
45	Climatic chamber	GTS500.40	GTS	1660	490073
46	Loop Antenna $\varnothing = 225$ mm	-	Phoenix Test-Lab	-	410085
47	RF-cable No. 11	RG223	Phoenix-Test-Lab	-	410103
-	-	-	-	-	-
-	-	-	-	-	-
-	-	-	-	-	-

All used measurement equipment was calibrated (if necessary). The calibration intervals and the calibration history will be given out on request.

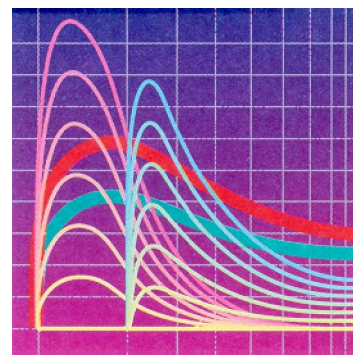

7 LIST OF ANNEXES

ANNEX A	PHOTOGRAPHS OF THE TEST SET-UPS:	5 pages
	Test set-up preliminary emission measurement (9 kHz to 30 MHz)	30013_6.jpg
	Test set-up preliminary emission measurement (30 MHz to 1 GHz)	30013_c.jpg
	Test set-up final emission measurement (9 kHz to 30 MHz)	30013_11.jpg
	Test set-up final emission measurement (30 MHz to 1 GHz)	30013_15.jpg
	Test set-up climatic chamber	30013_18.jpg
ANNEX B	EXTERNAL PHOTOGRAPHS OF THE TEST SAMPLE:	2 pages
	EUT, front view	30013eut1.jpg
	EUT, rear view	30013eut3.jpg
ANNEX C	EXTERNAL PHOTOGRAPHS OF THE TEST SAMPLE:	2 pages
	EUT, inside view	30013eut3.jpg
	PCB, front view	30013eut2.jpg