

POWERTouch™ P1000 Series

Radio Frequency (RF) Remote Control System

SERVICE MANUAL

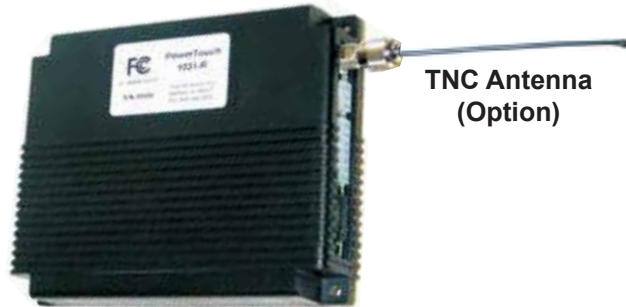

TNC Antenna
(Option)

Not Sealed

SYSTEM SPECIFICATIONS

Model # P1010-R6, P1030-R

RANGE	300 feet typical Up to 600 feet
OUTPUT OPTIONAL	6 Relays 7 Relays
INPUT	2 (+12v) A1 & A2 6 (+12v or Ground) B1-B6
FREQUENCY	433 MHz
CODES	Rolling Codes Secure Encryption
VOLTAGE	12 VDC 24 VDC (Special Order)
CURRENT	5 Amps Max per Output 10 Amp Input - Standard 30 Amp Input - Optional
ANTENNA OPTIONAL	Fixed - Standard TNC Whip (shown) Flex Whip / Roof Mount Flex Whip / Glass Mount
HARNESS	9" Standard, 14 Pin Connector Standard 6 Pin Connector Optional 2 Pin Connector Optional
BATTERY	All transmitter styles (except TX style)* • Coin Style, Lithium, CR2032 • 100,000 1-second pulses • 10 year shelf life *TX Style - 9V

Receiver can be paired to any transmitter below

TK Sealed Transmitters



P1000-TK1



P1000-TK2



P1000-TK4

TF Sealed Transmitters



P1000-TF2



P1000-TF2-LK



P1000-TF4



P1000-TF6

TM Transmitters



P1000-TM1



P1000-TM2



P1000-TM4

TX Transmitters



P1000-TX2S



P1000-TX4S



P1000-TX6S

← With ON/OFF Switch

57315 Nagy Dr
Elkhart, IN 46517

TouchTronics, Inc.

www.touchtronics.com

800-294-2570
574-294-2570

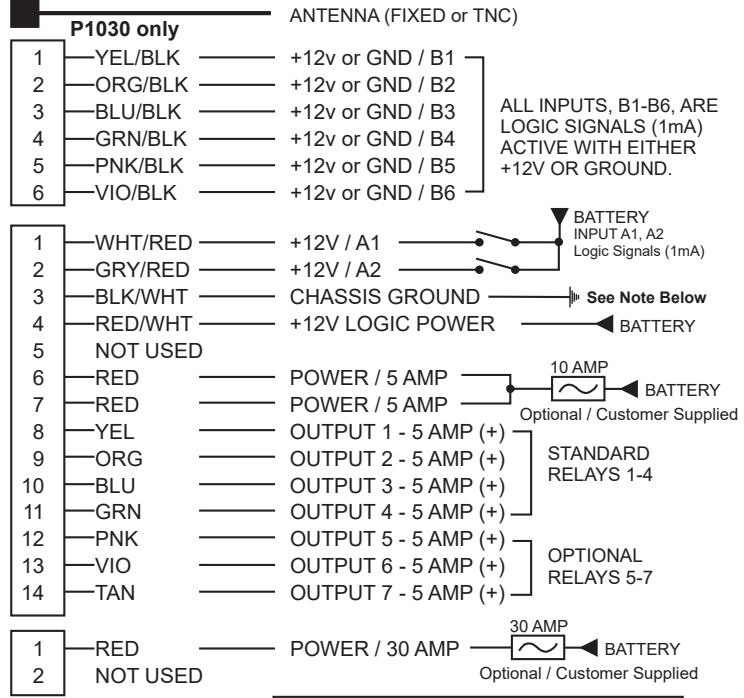
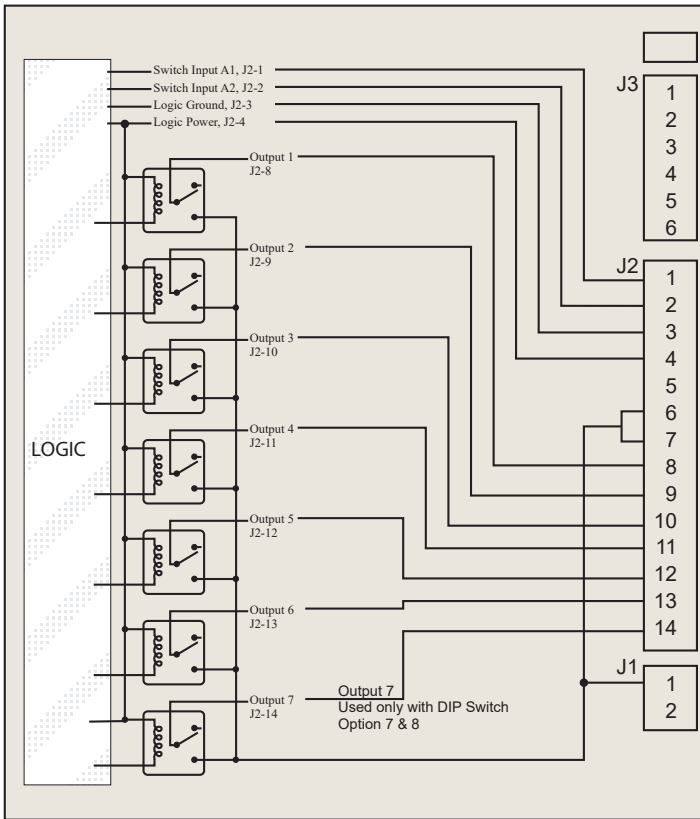

All output signals can be either +12VDC or Ground.
 For +12VDC output signals, supply +12vdc to:
 J1-1, J2-6 and J2-7
 For Ground output signals, supply +12vdc to:
 J1-1 and J2-7

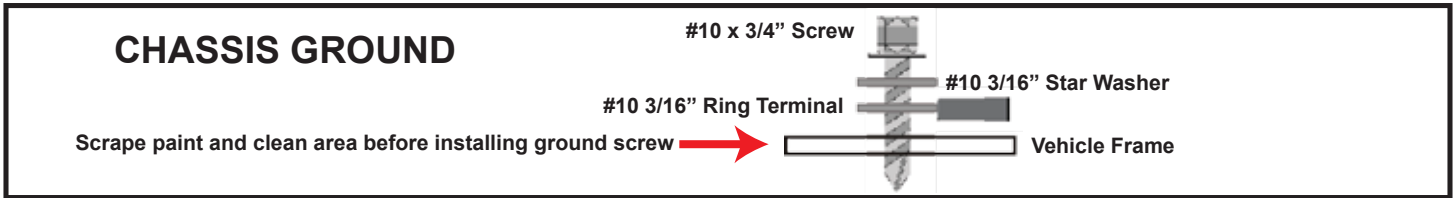
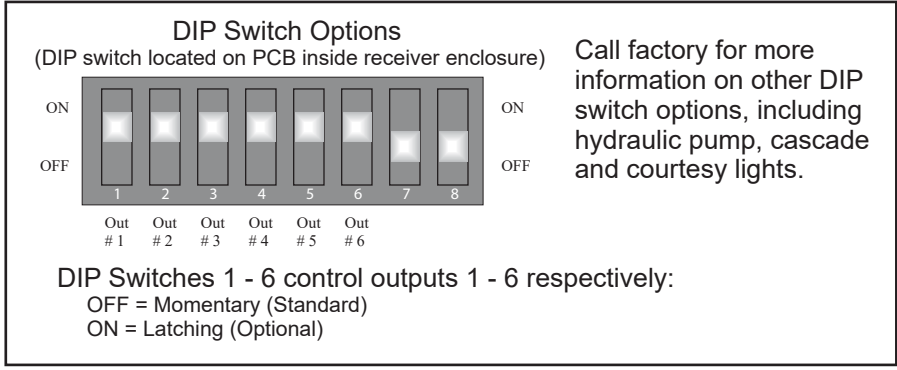

Call Factory for Custom Applications
TouchTronics, Inc. 1-800-294-2570

TouchTronics, Inc. Warranty Policies and Procedures

- 1) Each individual product is warranted under the TouchTronics Limited Warranty program for one (1) full year from the date of purchase or a maximum of two (2) years from the date of manufacture.
- 2) No product will be covered under the TouchTronics Limited Warranty Program that has a manufacture date older than two (2) years.
- 3) To receive technical support or warranty service, call our technical support center at 1-800-294-2570 during regular business hours.
- 4) To enable our technical support staff to better serve you, please have the following information available when you call:

Date Of:		Product Information:		Vehicle Information:	
Purchase		Model Number		Dealer Name	
Installation		Serial Number		Dealer Phone	
				Make / Model	

Please fill in all pertinent information at the time of purchase or installation.

TECHNICAL SUPPORT VIA WEB SITE / EMAIL www.touchtronics.com Techsupport@touchtronics.com or 'Contact Request' link on the web page	TECHNICAL SUPPORT NUMBERS Indiana Local 1-574-294-2570 Toll Free 1-800-294-2570 Fax 1-574-293-1611	SALES SUPPORT Phone 1-800-294-2570 Fax 1-574-293-1611 1Email sales@touchtronics.com
--	--	---

ACCESSORIES	
Part #	Description
ANT11405-1	TNC, Wire Whip Antenna (see page 1)
ANT10430-2	Glass Mount Antenna Kit, 14 foot cable
ANT11514-1	Flex Whip Antenna Kit, 10 foot cable, roof mount
<ul style="list-style-type: none"> • Minimum Order is \$25.00 • Call Factory for Current Pricing and Availability 	

<p>Section One Limited One (1) Year Warranty Seller will warrant any product originally manufactured or assembled and sold by seller for a period of up to TWO YEARS (24 months) from the original date of manufacture or ONE YEAR (12 months) from the original retail sale or O.E.M. in-service date.</p> <p>Section Two The following are in lieu of all warranties; expressed; implied; or statutory, including but not limited to, any implied warranty of merchantability of fitness for a particular purpose and of any other warranty obligation on the part of seller. Seller, except as otherwise hereinafter provided, warrants the goods against faulty workmanship or defective materials for a period of up to TWO YEARS (24 months) from the original date of manufacture or ONE YEAR (12 months) from the original retail or O.E.M. in-service date. Seller's sole and exclusive liability shall be (at seller's option) to repair; replace; or credit buyer for such goods which are returned by buyer during the applicable warranty period set forth above, provided that (I) seller is promptly notified in writing or by phone upon discovery by buyer that such goods failed to conform and an explanation of any alleged deficiencies, (II) such goods are returned to seller, (III) seller's examination of such goods shall disclose that such alleged deficiencies actually exist and were not caused by accident, misuse, neglect, alteration, improper installation, unauthorized repair or improper testing. If seller elects to repair or replace such goods, seller shall have a reasonable time to make such repairs or replace such goods. Seller's warranties as herein above set forth shall not be enlarged, diminished, or affected by, and no obligation or liability shall arise or grow out of, sellers rendering of technical advice or service. Damage to products caused by the customer or during installation cannot be claimed under this warranty. All devices returned that are not covered under the seller's warranty policy, will be charged a minimum of \$25.00 for evaluation plus additional charges for components and labor to repair the device not to exceed the original selling price. Seller considers the following to be typical examples of customer or installation damage: burned or broken traces on the printed circuit board, burned or damaged components, dirt or water residue on the printed circuit board or inside the case, modifications by the customer, broken cases or housings and dead batteries</p> <p>Section Three A return material authorization number (RMA) must be issued by seller before any product is returned for evaluation or repair. Warranty repairs must be completed at authorized repair facilities.</p> <p>© 2005 TouchTronics, Inc. All Rights Reserved. TouchTronics, the TouchTronics logo, and other TouchTronics marks are owned by TouchTronics and may be registered. TouchTronics assumes no responsibility for any errors that may appear in this manual. Information contained herein is subject to change without notice.</p> <p>FCC Compliance and Advisory Statement. This hardware device complies with Part 15 of the FCC Rules. Operation is subject to the following two conditions: 1) this device may not cause harmful interference, and 2) this device must accept any interference received, including interference that may cause undesired operation. This equipment has been tested and found to comply with the limits for a Class B digital device, pursuant to Part 15 of the FCC Rules. These limits are designed to provide reasonable protection against harmful interference in a residential installation. This equipment generates, uses, and can radiate radio frequency energy and, if not installed or used in accordance with the instructions, may cause harmful interference to radio communications. However, there is no guarantee that interference will not occur in a particular installation. If this equipment does cause harmful interference to radio or television reception, which can be determined by turning the equipment off and on, the user is encouraged to try to correct the interference by one or more of the following measures: 1) reorient or relocate the receiving antenna; 2) increase the separation between the equipment and the receiver 3) connect the equipment to an outlet on a circuit different from that to which the receiver is connected; 4) consult the dealer or an experienced radio/TV technician for help. Any changes or modifications not expressly approved by the party responsible for compliance could void the user's authority to operate the equipment. Where shielded interface cables have been provided with the product or specified additional components or accessories elsewhere defined to be used with the installation of the product, they must be used in order to ensure compliance with FCC regulations.</p> <p>Canadian DOC Statement. This digital device does not exceed the Class B limits for radio noise emissions from digital apparatus specified in the interference-causing equipment standard entitled "Digital Apparatus," ICES-003 of the Department of Communications.</p> <p>This device complies with RSS-210 of Industry Canada. Operation is subject to the following two conditions: 1) this device may not cause interference, and 2) this device must accept any interference, including interference that may cause undesired operation of the device.</p> <p>© 2005 TouchTronics, Inc. Tous droits réservés. TouchTronics, le logo TouchTronics et les autres marques TouchTronics sont la propriété exclusive de TouchTronics et sont susceptibles d'être des marques déposées. Toutes les autres marques sont la propriété exclusive de leurs détenteurs respectifs. TouchTronics décline toute responsabilité en cas d'erreurs dans ce manuel. Les informations énoncées dans le présent document peuvent faire l'objet de modifications sans avis préalable.</p> <p>Déclaration FCC. Cet équipement a été testé et déclaré conforme à la section 15 du règlement de la FCC. Son fonctionnement est soumis aux conditions suivantes: 1) l'équipement concerné ne doit pas causer d'interférences dangereuses, et 2) il doit accepter toute interférence reçue, y compris les interférences risquant d'engendrer un fonctionnement indésirable. Cet équipement a été testé et déclaré conforme aux limitations prévues dans le cadre de la catégorie B des appareils numériques défini par la section 15 du règlement de la FCC. Ces limitations sont stipulées aux fins de garantir une protection raisonnable contre les interférences gênantes en installation résidentielle. Cet équipement génère, utilise et diffuse des ondes radio, et s'il n'est pas installé ni utilisé en conformité avec les instructions dont il fait l'objet, peut causer des interférences gênantes avec les communications radio. Cependant, nous ne pouvons vous garantir qu'une interférence ne se produira pas dans une installation particulière. Si cet équipement produit des interférences graves lors de réceptions radio ou télévisées qui peuvent être détectées en allumant et en éteignant l'équipement, vous êtes invités à les supprimer de plusieurs manières: 1) Réorienter ou déplacer l'antenne de réception; 2) Augmenter la distance séparant l'équipement et le récepteur 3) Connecter l'équipement à un circuit différent de celui auquel le récepteur est connecté; 4) Contacter votre revendeur ou un technicien radio/TV qualifié. Toutes modifications ou tous changements effectués sans l'accord exprès de la partie responsable de la conformité aux normes pourraient contraindre l'utilisateur à ne plus utiliser son équipement. Afin d'assurer la conformité avec les règlements FCC, les câbles d'interface blindés fournis avec le produit doivent être utilisés, ainsi que tout autres composants ou accessoires également spécifiés, lors de l'installation du produit.</p> <p>Déclaration du Ministère des Communications Canadien. Cet appareil numérique est conforme aux limitations concernant l'émission d'interférences radio par des appareils numériques de catégorie B, telles que stipulées dans le cadre de la norme Appareils numériques ICES-003 édictée par le Ministère canadien de l'Industrie.</p> <p>Cet équipement a été déclaré conforme à la norme RSS-210 édictée par le Ministère canadien de l'Industrie. Son fonctionnement est soumis aux conditions suivantes: 1) l'équipement concerné ne doit pas causer d'interférences, et 2) il doit accepter toute interférence reçue, y compris les interférences risquant d'engendrer un fonctionnement indésirable.</p>
--