

**Matsushita Kotobuki
Electronics Industries Ltd.**

Storage Products Business Unit
Address: 2131-1 Minamigata, Kawauchi-cho, Onsen, Ehime 791 – 0395 Japan

Page 1 of 17 pages

TEST REPORT

REPORT NUMBER : MKM03F-003

APPLICANT : Matsushita Kotobuki
Electronics Industries, Ltd.

MODEL NUMBER : LKM-A121-BC

FCC ID : IUO9TB098DSS

Regulation : FCC Part15B Class B

Conducted Emission Test
Radiated Emission Test

Matsushita Kotobuki Electronics Ind., Ltd.
Storage Products Business Unit

2131-1 Minamigata, Kawauchi-cho, Onsen-gun,
Ehime-ken, 791-0395 Japan
Tel.: +81 89 966 2111 Fax.: +81 89 966 5733

TABLE OF CONTENTS

	Page
SECTION 1. <u>TEST CERTIFICATION</u>	3
SECTION 2. <u>EQUIPMENT UNDER TEST</u>	5
SECTION 3. <u>SUPPORT EQUIPMENT USED</u>	6
SECTION 4. <u>CABLE(S) USED</u>	7
SECTION 5. <u>CONSTRUCTION OF EQUIPMENT</u>	8
SECTION 6. <u>OPERATING CONDITIONS</u>	9
SECTION 7. <u>TEST PROCEDURE(S)</u>	10
SECTION 8. <u>EVALUATION OF TEST RESULTS</u>	11
SECTION 9. <u>PHOTOGRAPHS OF TEST SET-UP</u>	15
SECTION 10. <u>INSTRUMENTS USED FOR TEST</u>	16
SECTION 11. <u>PRECISION</u>	17
SECTION 12. <u>VALIDITY OF TEST REPORT</u>	17

SECTION 1. TEST CERTIFICATION**APPLICANT INFORMATION**

Company : Matsushita Kotobuki Electronics Industries, Ltd.
Address : 2131-1 Minamigata, Kawauchi-cho, Onsen-gun,
Ehime-ken, 791-0395 Japan

GRANTEE INFORMATION

Company : Matsushita Kotobuki Electronics Industries, Ltd.
Division / Section : Storage Products Business Unit Legal Affairs Team.
Address : 2131-1 Minamigata, Kawauchi-cho, Onsen-gun,
Ehime-ken, 791-0395 Japan
Telephone number : +81 89 966 2111
Fax number : +81 89 966 5733
Contact person : Shinji Yamauchi

DESCRIPTION OF TEST ITEM

Kind of equipment : S-AIT Tape Drive Unit
Trademark : Matsushita Kotobuki
FCC ID : IUO9TB098DSS
Model number : LKM-A121-BC
Serial number : HA3625X3M00001

TEST PERFORMED

FCC Registration No.	: 90793
Test started	: July 1, 2003
Test completed	: July 2, 2003
Purpose of test	: FCC Docket 87-389
Regulation	: FCC Part 15B Class B Unintentional Radiators
Test setup	: ANSI C63.4 -1992

Report file number : MKM03F-003

Report issue date : July 22, 2003

Test engineer : Shinji Yamauchi *S. Yamauchi*

Report approved by : Hisayuki Honda *H. Honda*
[Manager]

This equipment complies with above standard or regulation under the test condition or test configuration shown on this test report.

SECTION 2. EQUIPMENT UNDER TEST

The equipment under test (EUT) consists of the following equipment.

Indication in the following left side column corresponds to section 5.

Symbol	Item	Model No.	Serial No.	FCC ID	Manufacturer
A)	S-AIT Tape Drive Unit	LKM-A121-BC	HA3625X3M00001	IUO9TB098DSS	Matsushita Kotobuki Electronics Ind., Ltd.

Power ratings of EUT : AC 100V-240V, 50Hz/60Hz, 0.4A-0.7A

2.1 Port(s) / Connector(s) :

Fibre Channel Connector (2 pin TX/RX)

2.2 Oscillator(s) / Crystal(s) :

Oscillator	Operating Frequency	Board name	Remarks
20 MHz	20 MHz	Main PCB	
	80 MHz	Main PCB	
120MHz	120 MHz	Main PCB	High Frequency Module
	24 MHz	Main PCB	
13.56 MHz	13.56 MHz	Main PCB	
112 MHz	22.4 MHz	Main PCB	
113 MHz	22.6 MHz	Main PCB	
66 MHz	66 MHz	Interface PCB	
106.25MHz	106.25 MHz	Interface PCB	

SECTION 3. SUPPORT EQUIPMENT USED

The EUT has been supported by the following equipment during these tests. Indication in the following left side column corresponds to section 5.

Symbol	Item	Model No.	Serial No.	FCC ID	Manufacturer
B)	Interface Card	LSI409190	P2737964201	Declaration of Conformity	LSI Logic
C)	Host Computer	DHM	6NMW81X	Declaration of Conformity	DELL
D)	Keyboard	SK-8110	None	Declaration of Conformity	DELL
E)	Color Display	E151FPb	None	Declaration of Conformity	DELL
F)	Printer	3630A	3040A00351	BSD8533630A	HEWLETT PACKARD
G)	Mouse	X06-08477	5833432-6	Declaration of Conformity	DELL

SECTION 4. CABLE(S) USED

The following cable(s) was used for testing. Indication number in the following left side column corresponds to section 5.

Number	Name	Length	Shield	From	To
1)	Fibre Cannel cable	1.0 m	None	Interface Card Metal connector	EUT
2)	Keyboard I/F cable	2.0 m	Yes	Host Computer Metal connector	Keyboard
3)	Video Signal cable	1.7 m	Yes	Host Computer Metal connector	Color Display
4)	Mouse cable	1.8m	Yes	Host Computer Metal connector	Mouse
5)	Parallel I/F cable	1.5 m	Yes	Host Computer Metal connector	Printer
6)	Power cord for Host Computer	1.9 m	None	Host Computer	Power Source
7)	Power cord for Color Display	1.7 m	None	Color Display	Power Source
8)	Power cord for Printer	2.0 m	None	Printer	AC Adapter
9)	Power cord for Printer	2.0 m	None	AC Adapter	Power Source
10)	Power cord for EUT	1.8m	None	EUT	Power Source

None :

All cables are not attached ferrite core.

SECTION 5. CONSTRUCTION OF EQUIPMENT

The construction of EUT during testing is as follows.

System configuration

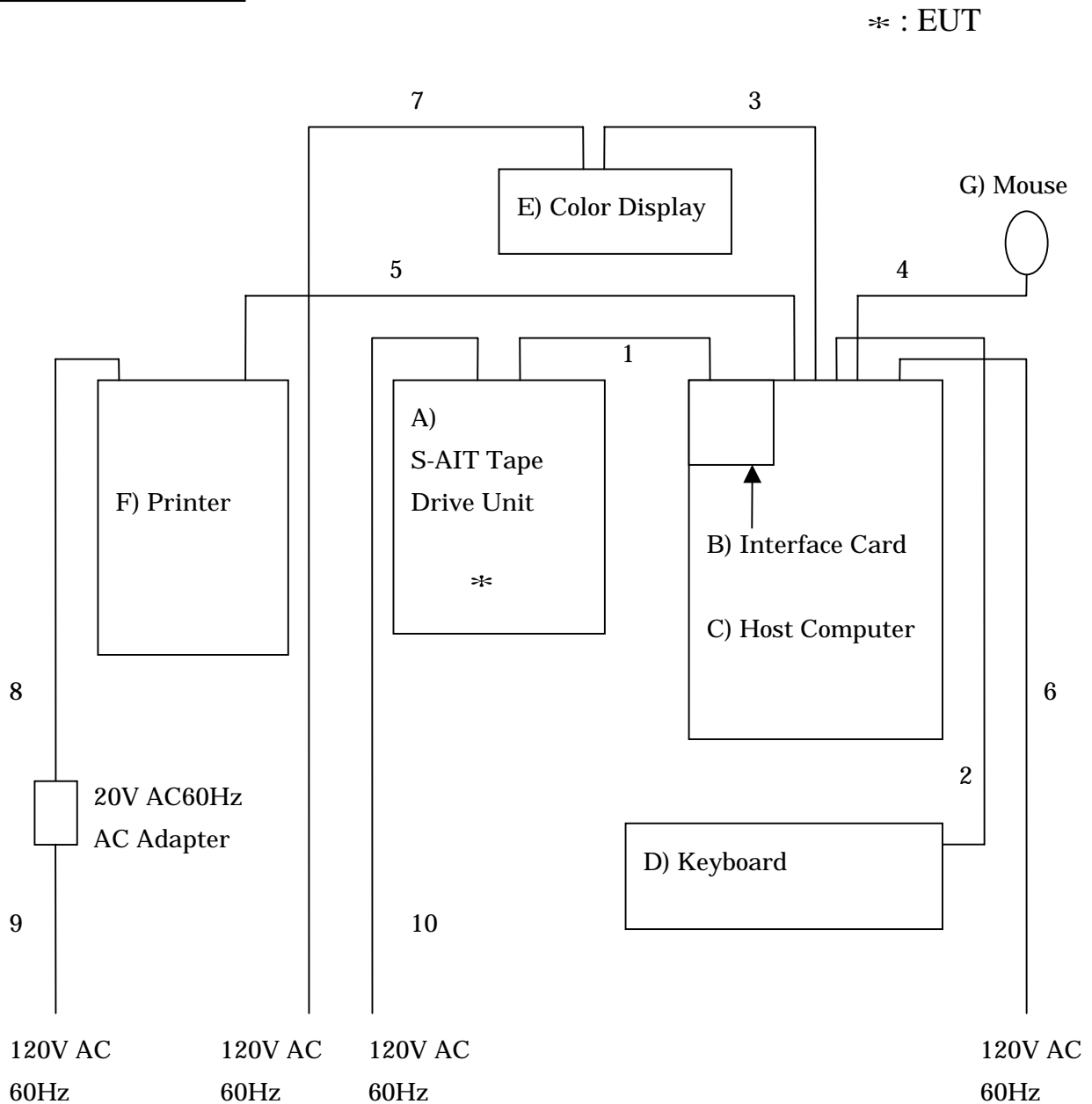

Symbol or numbers assigned to equipment or cables on this diagram are corresponded to the symbols or numbers assigned to equipment or cables on tables in Sections 2 to 4.

SECTION 6. OPERATING CONDITIONS

The EUT has been operated under the following conditions during the tests.

6.1 Operating condition

The tests have been carried out under Write mode.

6.2 Operation flow

Performed following operations continuously.

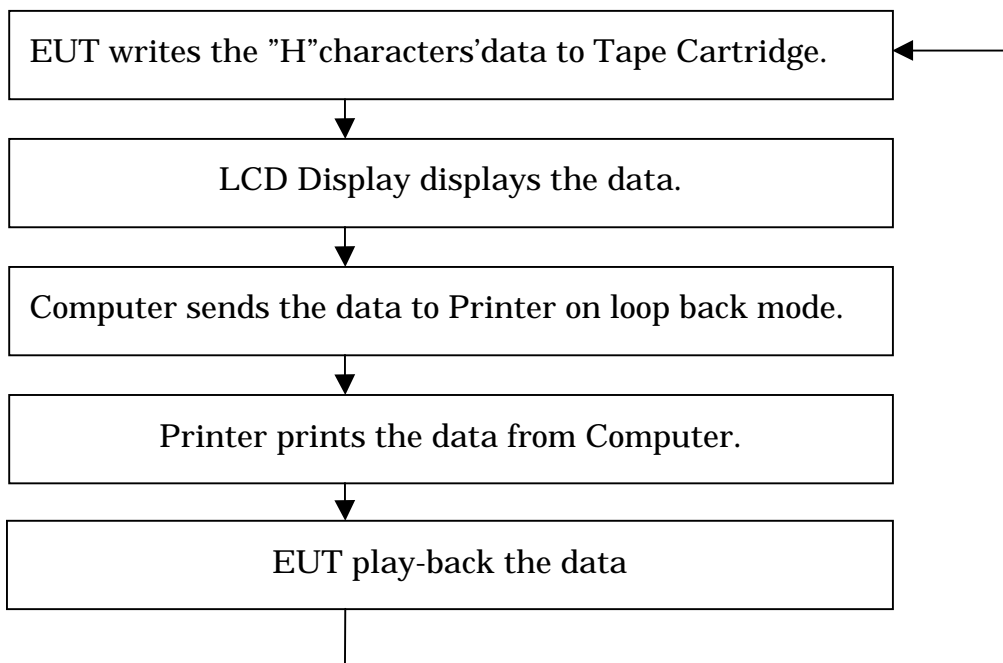

SECTION 7. TEST PROCEDURE(S)

Tests have been carried out with the test procedure(s) drawn up by our laboratory which is in accordance with the following test procedure(s).

Test item	Test procedure used	Scanned Frequency Range
Conducted Emission	ANSI C63.4-1992	0.15 - 30 MHz
Radiated Emission	ANSI C63.4-1992	30 - 2000 MHz

SECTION 8. EVALUATION OF TEST RESULTS

8.1 Conducted Emission Test

Product Name	: S-AIT Tape Drive Unit
Model No.	: LKM-A121-BC
Serial No.	: HA3625X3M00001
Power Supply	: 120V / 60Hz
Test Mode	: Write mode
Temp / Humi / Pres	: 26°C / 51% / 999hPa
Operator	: S. Yamauchi

No	Freq. [MHz]	Reading Level		Factor [dB]	Emission Level		Limit [dBuV]	Margin [dB]
		Va [dBuV]	Vb [dBuV]		Va [dBuV]	Vb [dBuV]		
1	0.184	55.0	----	0.1	55.1	----	64.3	9.2
2	0.181	----	54.2	0.1	----	54.3	64.4	10.1
3	0.387	33.6	----	0.1	33.7	----	58.1	24.4
4	0.434	----	37.2	0.1	----	37.3	57.2	19.9
5	0.432	40.2	----	0.1	40.3	----	57.2	16.9
6	5.679	----	17.8	0.3	----	18.1	60.0	41.9
7	5.907	16.3	----	0.3	16.6	----	60.0	43.4
8	24.886	30.8	----	1.2	32.0	----	60.0	28.0
9	24.894	----	33.0	1.2	----	34.2	60.0	25.8

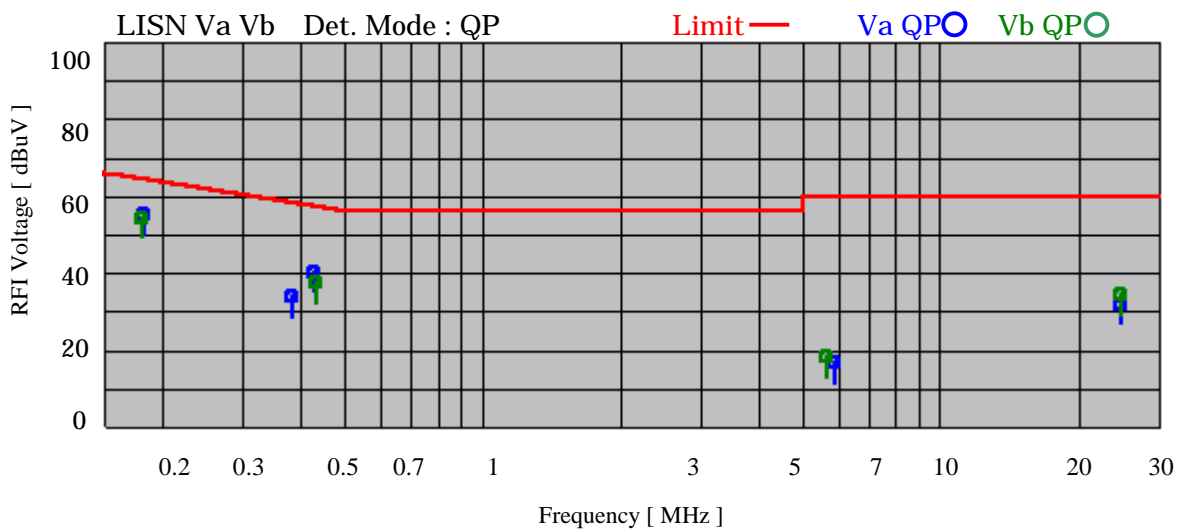

8.2 Radiated Emission Test

Product Name	: S-AIT Tape Drive Unit
Model No.	: LKM-A121-BC
Serial No.	: HA3625X3M00001
Power Supply	: 120V / 60Hz
Test Mode	: Write mode
Temp / Humi / Pres	: 26°C / 51% / 999hPa
Operator	: S. Yamauchi

[Quasi Peak mode]

No	Freq. [MHz]	Reading Level [dBuV]		Factor [dB]	Emission Level [dBuV/m]		Limit [dBuV/m]	Margin [dB]
		Hor.	Ver.		Hor.	Ver.		
1	44.744	----	14.5	13.5	----	28.0	40.0	12.0
2	59.971	----	14.8	9.2	----	24.0	40.0	16.0
3	151.668	10.2	----	16.5	26.7	----	43.5	16.8
4	189.068	----	11.1	17.8	----	28.9	43.5	14.6
5	261.128	16.2	----	19.3	35.5	----	46.0	10.5
6	733.030	----	11.2	25.9	----	37.1	46.0	8.9
7	733.060	13.1	----	25.9	39.0	----	46.0	7.0

[Peak mode]

No	Freq. [MHz]	Reading Level [dBuV]		Factor [dB]	Emission Level [dBuV/m]		Limit [dBuV/m]	Margin [dB]
		Hor.	Ver.		Hor.	Ver.		
1	1062	----	56.0	-11.3	----	44.7	74.0	29.3
2	1487	----	55.7	-8.8	----	46.9	74.0	27.1

[Average mode]

No	Freq. [MHz]	Reading Level [dBuV]		Factor [dB]	Emission Level [dBuV/m]		Limit [dBuV/m]	Margin [dB]
		Hor.	Ver.		Hor.	Ver.		
1	1062	----	53.1	-11.3	----	41.8	54.0	12.2
2	1487	----	52.8	-8.8	----	44.0	54.0	10.0

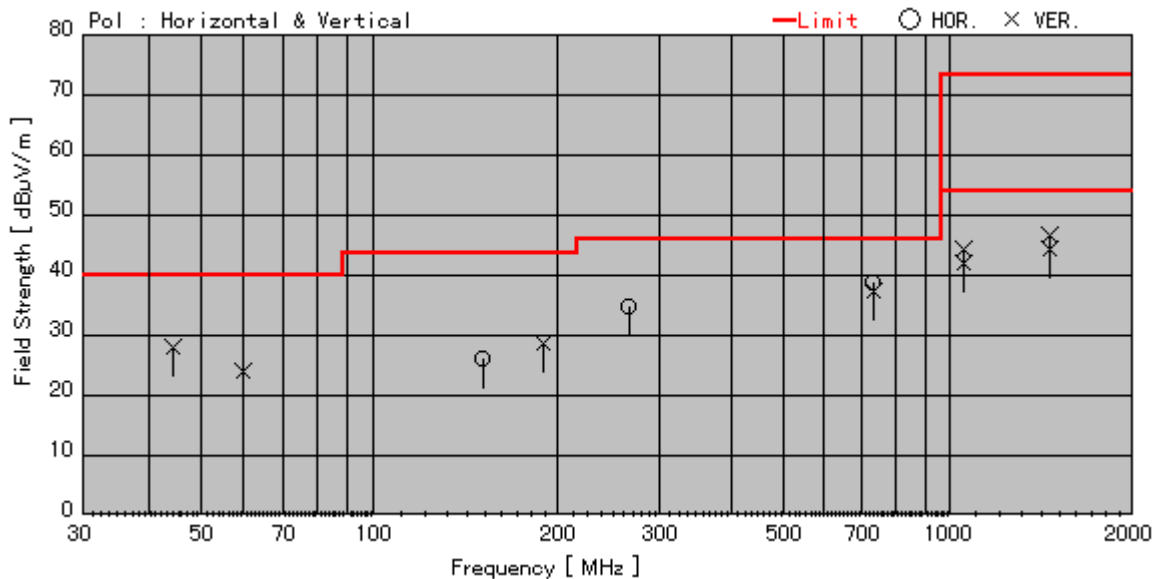

8.3 Conclusion

This test report clearly shows that the EUT is in compliance with the FCC Part 15B, Class B specification.

The minimum margins to the limits are as follows:

Conduction measurement	9.2 dB	at	0.184 MHz
Radiation measurement	7.0 dB	at	733.060 MHz

8.4 Sample Calculations

8.4.1 Conducted Emission

Example @ 0.184 MHz

$$\begin{array}{rcl}
 \text{Emission Level} & = & \text{Meter Reading} & 55.0 \text{ dBuV} \\
 & & + \text{ A.M.N. Factor} & + 0.1 \text{ dB} \\
 & & & \hline
 & & = & 55.1 \text{ dBuV}
 \end{array}$$

$$\begin{array}{rcl}
 \text{Margin} & = & \text{Limit} & 64.3 \text{ dBuV} \\
 & & - \text{ Emission Level} & - 55.1 \text{ dBuV} \\
 & & & \hline
 & & = & 9.2 \text{ dB}
 \end{array}$$

A.M.N. : Artificial Mains Network = Line Impedance Stabilization Network (LISN)

8.4.2 Radiated Emission

Example @ 733.060 MHz

$$\begin{array}{rcl}
 \text{Emission Level} & = & \text{Meter Reading} & 13.1 \text{ dBuV} \\
 & & + \text{ Factor} & + 25.9 \text{ dB} \\
 \text{(Factor = Antenna Factor + Cable Loss)} & & & \hline
 & & = & 39.0 \text{ dBuV/m}
 \end{array}$$

$$\begin{array}{rcl}
 \text{Margin} & = & \text{Limit} & 46.0 \text{ dBuV/m} \\
 & & - \text{ Emission Level} & - 39.0 \text{ dBuV/m} \\
 & & & \hline
 & & = & 7.0 \text{ dB}
 \end{array}$$

SECTION 9. PHOTOGRAPHS OF TEST SET-UP

Test setup in accordance with ANSI C63.4-1992

9.1 Conducted Emission Test



Front View



Rear view

9.2 Radiated Emission Test



Front View



Rear view

Note : Maintaining 10cm spacing between all the equipment cabinets.

SECTION 10. INSTRUMENTS USED FOR TEST

Instrument	Model No.	Serial No.	Manufacturer	Last cal.	Period
EMI Test Receiver	85462A	3520A00241	Hewlett Packard	8/2002	1 Year
RF Filter Section	85460A	3448A00210	Hewlett Packard	8/2002	1 Year
PREAMPLIFIER	8449B	3008A01744	Agilent technologies	8/2002	1 Year
Biconical Antenna	BBA9106	None	Schwarzbeck	10/2002	1 Year
Logperiodic Antenna	UHALP9107	1622	Schwarzbeck	10/2002	1 Year
Double Ridged Antenna	3115	9702-5139	EMCO	9/2002	1 Year
Artificial Mains Network(AMN)					
= Line Impedance Stabilization Network(LISN)					
	ESH3-Z5	840062/024	Schwarzbeck	7/2002	1 Year
Artificial Mains Network(AMN)					
= Line Impedance Stabilization Network(LISN)					
	ESH3-Z5	840062/028	Schwarzbeck	8/2002	1 Year

SECTION 11. PRECISION

Tolerances of the measuring instruments are shown on below.

- | | |
|--|----------------------|
| 1. Antenna factor | ± 2.0 dB |
| 2. Cable loss | ± 1.0 dB |
| 3. EMI test receiver | ± 2.0 dB |
| 4. Artificial Mains Network(AMN)
= Line Impedance Stabilization Network(LISN) | impedance $\pm 20\%$ |
| 5. Site Attenuation | ± 4.0 dB |

Repeatability and reproducibility about maximum emission setup are not specified herein.

SECTION 12. VALIDITY TEST REPORT

- 12.1 The test result of this report is effective for equipment under test itself and under the test configuration described on the report.
- 12.2 This test report does not assure that whether the test result taken in other testing laboratory is compatible or reproducible to the test result on this report or not.
- 12.3 Copying of this report without permission is prohibited.