

Block Diagram

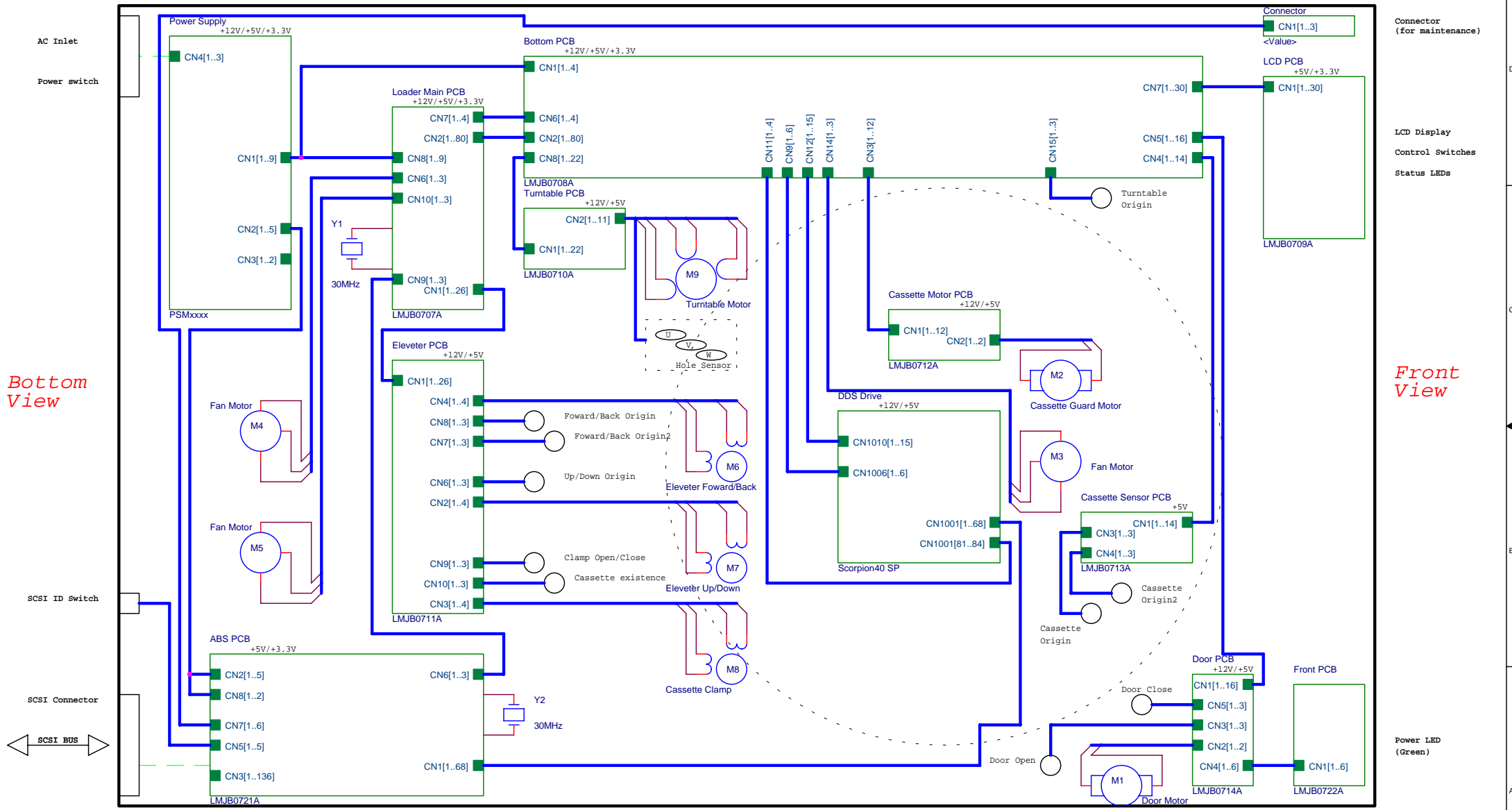

Caution

AC inlet, power switch, SCSI connector and SCSI ID switch take out direct outside.

Title		
LKM-SD21-S		
Size	Document Number	Rev
B	MKE	1.0
Date:	Friday, May 31, 2002	Sheet 1 of 1