

CD-ROM DRIVE UNIT

CR-594-J / CR-594-K

INSTRUCTION MANUAL

Please read through these instructions before operating this unit.

Interface : ATAPI

CD-ROM DRIVE UNIT CR-594-J / CR-594-K INSTRUCTION MANUAL

Please read through these instructions before operating this unit.
Interface : ATAPI

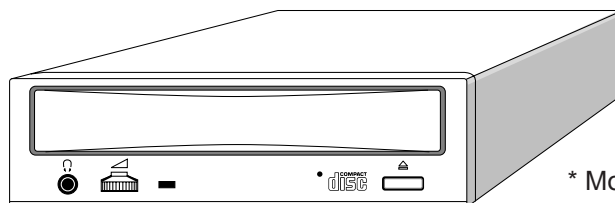

* Model CR-594-J

TABLE OF CONTENTS

IMPORTANT SAFETY NOTICE	iv
LASER SAFETY INFORMATION	A-1
INTRODUCTION	A-2
1. PRECAUTIONS WHEN OPERATING	A-3
1.1 PRECAUTIONS WHEN TRANSPORTING	A-3
1.2 INSTALLATION LOCATION	A-3
1.3 PRECAUTIONS FOR USE	A-3
1.4 PRECAUTIONS FOR OPERATION	A-3
1.5 PRECAUTIONS WHEN HANDLING DISCS	A-3
2. PARTS AND FUNCTIONS	A-5
2.1 FRONT VIEW	A-5
2.2 REAR VIEW	A-5
3. CONNECTIONS	A-6
3.1 CONNECTING VIEW	A-6
4. GUIDE TO OPERATION	A-6
4.1 INSTALLATIONS	A-6
5. GENERAL DESCRIPTION	A-7
5.1 FEATURE SUMMARY	A-7
5.2 SYSTEM SET UP	A-7
5.3 POWER SAVING	A-7
6. SPECIFICATION SUMMARY	A-7
6.1 PERFORMANCE	A-7
6.2 ERROR RATES	A-8
6.3 AUDIO PERFORMANCE	A-8
6.4 GENERAL PERFORMANCE	A-9
6.5 ENVIRONMENTAL CONDITIONS	A-9
6.6 PICK UP LASER	A-9
7. BEFORE REQUESTING SERVICE	A-9
7.1 TROUBLESHOOTING	A-9
APPENDIX	A-10

IMPORTANT SAFETY NOTICE

NOTICE

- (1) You may not reproduce or transcribe any part of this publication without permission.
- (2) We reserve the right to revise this document at any time without notice.
- (3) If you have any questions about this document, contact your sales representative.

SAFETY NOTICE

- (1) To prevent fire or electric shock, do not expose this appliance to rain or moisture.
- (2) To avoid electric shock or damage to the eyes due to laser beam, do not attempt to disassemble the cabinet.

For USA (Model CR-594-J only)

FEDERAL COMMUNICATIONS COMMISSION (FCC) RADIO FREQUENCY INTERFERENCE STATEMENT

Class B Computing Device

NOTE : This equipment has been tested and found to comply with the limits for a Class **B** digital device, pursuant to part 15 of the FCC Rules. These limits are designed to provide reasonable protection against harmful interference in a residential installation. This equipment generates, uses and can radiate radio frequency energy and , if not installed and used in accordance with the instructions, may cause harmful interference to radio communications. However, there is no guarantee that interference will not occur in a particular installation. If this equipment does cause harmful interference to radio or television reception, which can be determined by turning the equipment off and on, the user is encouraged to try to correct the interference by one or more of the following measures :

- - Reorient or relocate the receiving antenna.
- - Increase the separation between the equipment and receiver.
- - Connect the equipment into an outlet on a circuit different from that to which the receiver is connected.
- - Consult the dealer or an experienced radio/TV technician for help.

FCC WARNING : Changes or modifications not expressly approved by the party responsible for compliance could void the user's authority to operate the equipment.

LASER SAFETY INFORMATION

Class 1 LASER Product

This equipment is certified to comply with DHHS Rule 21 CFR Chapter 1, Subchapter J in effect as of date of manufacture.

Elsewhere, the drive is certified to conform to the requirements of the International Electrotechnical Commission (IEC) 825 and CENELEC EN60825 for Class 1 laser products.

Class 1 laser products are not considered to be hazardous. To ensure continued product safety, the following precautions should be heeded.

Caution :

- (1) The use of controls or adjustments or performance of procedures other than those specified herein may result in hazardous radiation exposure.
- (2) The drive is designed to be incorporated into a computer-based system or unit which has an enclosing cover. The drive may not be used as a stand-alone unit.
- (3) Do not open the drive unit; no user adjustments or serviceable parts are inside.

CLASS 1 LASER PRODUCT	LASER KLASSE 1
LUOKAN 1 LASERLAITE	KLASS 1 LASER APPARAT
APPAREIL A LASER DE CLASSE 1	EN60825

- This label is attached to the upper shield at the top of the drive unit.
- Dieses Etikett ist auf der oberen Abschirmung oben auf der Laufwerkseinheit angebracht. (For German)
- Märkningen återfinns på den översta kåpan överst på drivenheten. (For Swedish)
- Denne merkelappen er festet til det øverste dekselet på toppen av spilleren. (For Norwegian)
- Denne etiket er sat fast på den øverste skærm på drev-enhedens top. (For Danish)
- Tämä etiketti on liimattu voimayksikön yläosan suojalevyyn. (For Finnish)

LASER Specification

Type: Semiconductor laser AlGaAs
 Wave Length: 760 ~ 815 nm (Typical 785 nm)
 Divergence: $\theta = 53,5^\circ$
 Output Power: 0.15 mW

Laser-Daten: (For German)

Typ: Halbleiter-Laser AlGaAs
 Wellenlänge: 760 ~ 815 nm (Typical 785 nm)
 Divergenz: $\theta = 53,5^\circ$
 Ausgangsleistung: 0,15 mW

Laser- specifikationer: (For Swedish)

Typ: Laserhalvedare AlGaAs
 Våglängd: 760 ~ 815 nm (Typiskt 785 nm)
 Divergens: $\theta = 53,5^\circ$
 Uteffekt: 0,15 mW

LASER Spesifikasjon: (For Norwegian)

Type: Halvleder laser AlGaAs
 Bølgelengde: 760 ~ 815 nm (Typisk 785 nm)
 Divergens: $\theta = 53,5^\circ$
 Utgangseffekt: 0,15 mW

Laser Specifikationer: (For Danish)

Type: Semiconductor AlGaAs
 Bølge-længde: 760 ~ 815 nm (Typisk 785 nm)
 Divergens: $\theta = 53,5^\circ$
 Udgang-effekt: 0,15 mW

LASERin tekniset tiedot: (For Finnish)

Tyyppi: Laserpuolijohdin AlGaAs
 Aallon pituus: 760 ~ 815 nm (Tyypillinen 785 nm)
 Hajaantumisen: $\theta = 53,5^\circ$
 Teho: 0,15 mW

INTRODUCTION

CD-ROM drive is read-only memory using an audio compact disc system as a media package which handles digital data. To enjoy audio CD, please insert the Headphone plug into the Headphone jack. (Model CR-594-J only)

This drive unit uses CD-ROM discs which bear the following mark.



Only compact discs having this mark can be used with this unit.

**System Requirements**

- Computer
 - IBM PC-AT or Compatible
- Operating System
 - PC-DOS Ver. 5.0 or later
 - MS-DOS Ver. 5.0 or later
 - MS Windows 3.1/NT3.5/NT3.51/NT4.0
 - MS Windows 95 / 98
 - OS/2 2.1X or later

CHAPTER 1 PRECAUTIONS WHEN OPERATING

1.1 PRECAUTIONS WHEN TRANSPORTING

To avoid damage

- * Keep the original packing materials for the drive unit.
- * Before you transport the drive unit, remove the disc from the drive unit and repack the drive unit in its original packing.

1.2 INSTALLATION LOCATION

Do not place unit in the following environments.

- * High-temperature, high-humidity, extreme temperature changes.
- * Dusty
- * Excessive vibration/ sudden shock.
- * Inclined place.
- * Direct sunlight.

1.3 PRECAUTIONS FOR USE

- * Never push objects of any kind through the Cabinet slots, never spill liquid of any kind on the unit.
- * Do not place objects on the product.
- * Do not attempt to service this product yourself.
- * Do not open or remove covers.
- * Do not place foreign objects in the disc insertion slot and attempt to operate.
- * Do not use CD-ROM drive when vertically installed. (Horizontal installation type only)

1.4 PRECAUTIONS FOR OPERATION

To avoid error

- * Do not move the drive unit during operation.
- * Do not operate the unit directly after a sudden increase in temperature.

NOTE :

A great proportion of problems are usually caused by the following.

- ① Dust or Finger-prints on the surface of the CD-disc.
- ② Random Electrical Noise.
- ③ Scratches and Defects on the surface of the CD-disc.

1.5 PRECAUTIONS WHEN HANDLING DISCS

- ① Hold the disc by the edges, do not touch the surface of the disc.

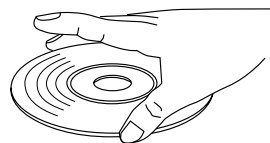

- ② To remove dust or fingerprint, use a clean, soft, dry cloth.

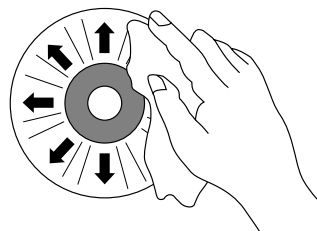

- ③ Do not write on, or paste paper to the surface of the disc.
Should not paste any label to the outer back surface (the label side) of the disc, or it generates drive vibration due to imbalance of the disc.

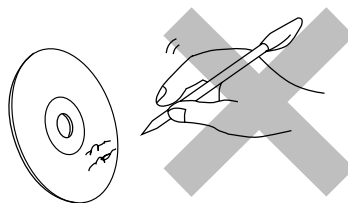

- ④ Do not store the disc in a place where the temperature is high.

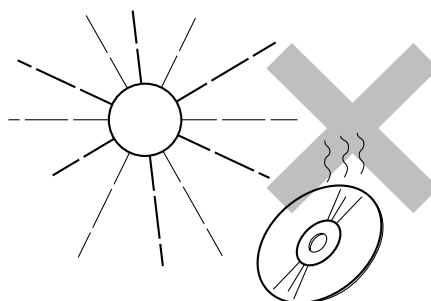

- ⑤ Do not use benzine, thinners and cleaners, etc.



- ⑥ Do not make the center hole larger.



- ⑦ Do not bend the disc.

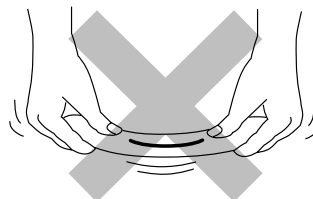

- ⑧ Do not drop the disc, or subject it to shock.

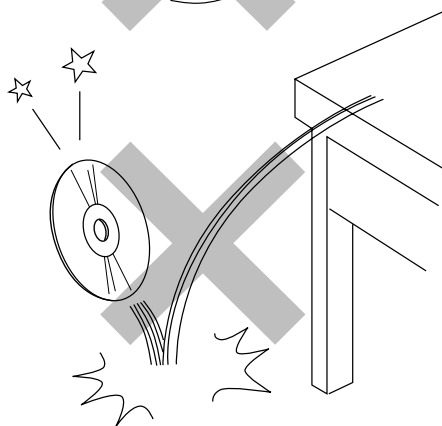

CHAPTER 2 PARTS AND FUNCTIONS

2.1 FRONT VIEW

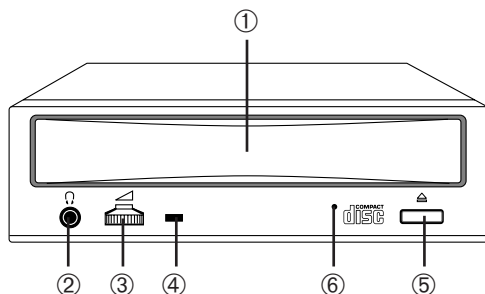

- ① **DISC TRAY**
Accepts a disc.
- ② **HEAD PHONE JACK** (Model CR-594-J only)
Headphone can be connected using a 3.5mm stereo mini plug.
- ③ **VOLUME** (Model CR-594-J only)
Adjusts audio output level of Headphone.
- ④ **BUSY INDICATOR**
Lights when data is being accessed from the disc, or the drive is playing an audio CD.
- ⑤ **EJECT / LOAD BUTTON**
Ejects and loads the disc tray.
- ⑥ **EMERGENCY EJECT HOLE**
Insert an instrument such as straightened paper clip into this hole to manually eject the tray. (See 4.1)

2.2 REAR VIEW

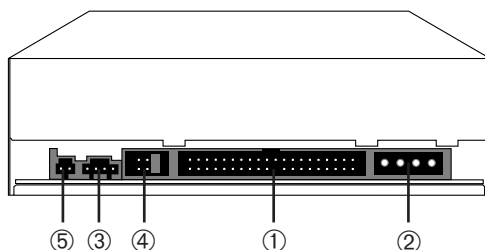

- ① **INTERFACE CONNECTOR**
Connects to host computer's interface connector.
- ② **DC (IN) CONNECTOR**
- ③ **AUDIO OUT CONNECTOR** (Analog)
- ④ **JUMPER PIN**
Insert the jumper according to the Master / Slave / CSEL drive.
(See the figure in the next page.)
- ⑤ **DIGITAL AUDIO OUT CONNECTOR**

CHAPTER 3 CONNECTIONS

3.1 CONNECTING VIEW

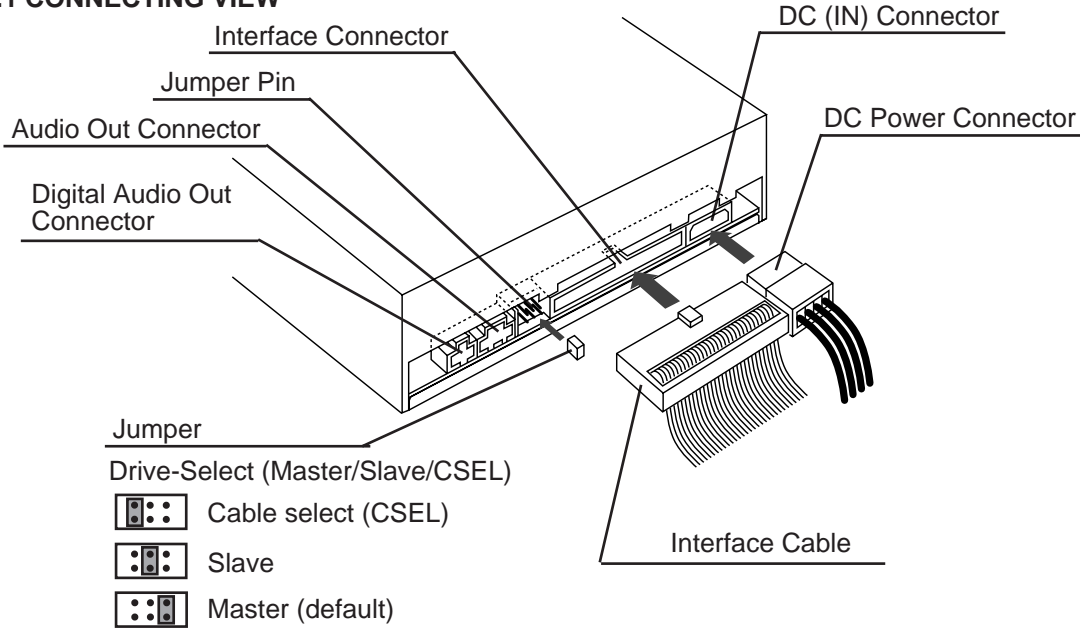

CHAPTER 4 GUIDE TO OPERATION

4.1 INSTALLATIONS

• Starting the drive.

- ① Turn on the power supply.
- ② Press the eject button. The tray is ejected from the drive.
- ③ Place the disc in the tray with the disc's label facing up.
- ④ Press the eject button or press the tray lightly as in the following figure. The tray is retracted automatically.
- ⑤ Loading start.

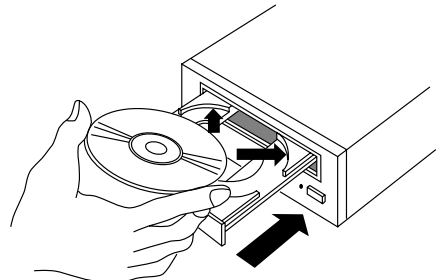

* This figure shows in case of Horizontal Installation.

CAUTION:

- Do not insert any foreign objects into the disc tray. This could result in a malfunction.
- Do not manually force the tray to open.
- When the drive is not in use, keep the tray closed to protect against dust and dirt.
- Do not press down hard on the tray when loading a disc, since this may result in damage to or malfunction of the tray.

- In case of emergency, eject the tray manually
If for some reason the tray will not eject automatically, press the eject-bar (for example, insert a straightened paper clip minimum straight length = 45mm, Diameter = 1~ 1.5mm) into the emergency eject hole to manually eject the tray. (Before proceeding with this emergency step, make sure that the power is switched OFF.)

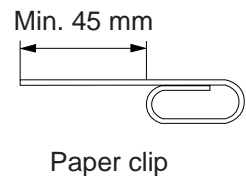

CHAPTER 5 GENERAL DESCRIPTION

5.1 FEATURE SUMMARY

- ① Embedded ATAPI Interface.
- ② Automatic Loading with tray.
- ③ Horizontal and Vertical Installation.
(Vertical : Vertical installation type only, 12 cm Disc only)
- ④ Audio Playback Capability.
- ⑤ MS-DOS CD-ROM Extensions Available.
- ⑥ 5 1/4" Half Height Design.

5.2 SYSTEM SET UP

The ATAPI Devices are selected by the Address field in the Drive Select Register. When a single Device is attached to the interface, it shall be set as Device 0. When the ATAPI Device is attached along with an ATA Mass Storage Device, the ATAPI Device will be set as Device 1 and respond as a Slave.

5.3 POWER SAVING

- ① When the drive waits for a command from the Host for more than five minutes, then the drive enters Power Save Mode. Laser and Spindle motor stop.
- ② Re-start is automatic when the Host Command is received.

NOTE :

- **ATAPI** : AT Attachment Packet Interface.
- **MS-DOS** and **MS Windows** are trademarks or registered trademarks of Microsoft Corporation.
- **IBM PC-AT** and **OS/2** are registered trademarks of International Business Machines Corporation.

CHAPTER 6 SPECIFICATION SUMMARY

6.1 PERFORMANCE

- | | |
|---|--|
| ① Disc diameter | 12 cm, 8 cm |
| ② Disc speed
(48x mode) *1 | 9480 ~ 10000 r/min (CAV) *2 |
| ③ Data capacity | 656 MBytes (Mode 1)
748 MBytes (Mode 2) |
| ④ Data transfer Rate
Sequential (48x mode) | 3103 ~ 7200 KBytes/s (Mode 1)
(mean value; 5152 KBytes/s) |
| From buffer | 16.7 MBytes/s (PIO Mode 4)
16.7 MBytes/s (Multi-word DMA Mode 2)
8.3 MBytes/s (Single word DMA Mode 2)
33.3 MBytes/s (Ultra DMA Mode 2) |

⑤ Access time

Random access time *3	(48x mode)	90 ms [typical]
Fullstroke access time *4	(48x mode)	180 ms [typical]

⑥ Buffer Size

128 KBytes

MTBF

125,000 POH (DUTY 20%)

NOTE:

*1 48x mode: 48x speed mode

*2 CAV : Constant Angular Velocity

*3 Random access time : Average Data read over the complete area from 00 min. 02 sec. 00 block to 59 min. 58 sec. 74 blocks, more than 2000 times including latency and layered error correction time.

*4 Fullstroke access time : From 00 min. 02 sec. 00 block to 59 min. 58 sec. 74 blocks including latency and layered error correction time.

6.2 ERROR RATES

- Soft read errors Less than 10^{-9}
- Hard read errors Less than 10^{-12}

6.3 AUDIO PERFORMANCE

(1) Analog audio (Headphone functions with Model CR-594-J only)

- | | |
|----------------------|--|
| ① Number of channels | 2 |
| ② Frequency response | 20 Hz ~ 20 kHz (Line-out)
100 Hz ~ 20 kHz (Headphone) |
| ③ SN Ratio | More than 80 dB (Line-out / Headphone) |
| ④ Distortion | |
| • Line-out | Less than 0.1% (1 kHz) |
| • Headphone | Less than 0.2% (1 kHz) |
| ⑤ Output level | |
| • Line-out | 0.60 Vrms [typical] |
| • Headphone | 0.60 Vrms [typical] |

(2) Digital audio

- | | |
|----------------|----------------------------|
| ① Output level | TTL level |
| ② Data format | Base a decision on IEC-958 |

6.4 GENERAL PERFORMANCE

① Power rating	+5 V ≐ 1.5 A
	+12 V ≐ 1.8 A
② Dimensions (W x H x D)	146 x 41.3 x 190 mm (exclude Front Bezel)
③ Weight	865 g [typical]

6.5 ENVIRONMENTAL CONDITIONS

	Operating	Non-operating
• Temperature	5 ~ 50 °C	- 30 ~ 65 °C
• Humidity	5 ~ 90 %Rh (Non-condensation)	5 ~ 95 %Rh (Non-condensation)

6.6 PICK UP LASER

• Type	Semiconductor laser AlGaAs
• Wave Length	760 ~ 815 nm (Typical 785 nm)
• Divergence	$\theta = 53.5^\circ$
• Output power	0.15 mW

CHAPTER 7 BEFORE REQUESTING SERVICE

7.1 TROUBLESHOOTING

- (1) There are many kinds of problems caused by misuse. When a problem occurs, check the table below which describes possible problems occurring with your CD-ROM drive.
- (2) If the CD-ROM drive is not operating correctly and you cannot restore operation by following the detailed procedures in the table below, do not remove the cover of the units or adjust further.
- (3) In the case of (2) above, unplug the unit and consult with your dealer or the nearest service station.

TROUBLE	CORRECTION
<ul style="list-style-type: none"> • CD-ROM drive does not operate and Busy Indicator does not light. 	<ol style="list-style-type: none"> ① Confirm that the connection between the CD-ROM drive and the host computer is correct. ② Confirm that the program is correct. ③ Confirm that the setting drive select switch is correct. ④ Confirm that the disc has been inserted label side up. ⑤ Confirm that foreign objects have not been inserted.

APPENDIX

Easy Installation of the Software for DOS / Windows 3.1

The CR-594-J/K CD-ROM drive must be installed into your host computer, before installing this software.

1. Turn the power of your personal computer on. If your system automatically loads Windows, you must exit Windows and reach the DOS prompt C:\.
This explanation assumes that your floppy drive is designed "A" and your hard disk drive "C". If, however, you have used other letters to designate your drives, please substitute the appropriate letters.
2. Insert the floppy disk "M.K.E ATAPI Device Driver" into your floppy disk drive.
3. Type **A:** and press <Enter>.
The current drive changes to "A".
4. Type **INSTALL** and press <Enter>.
The software will then ask the destination drive as well as other parameters. The software will then be transferred, and the CONFIG.SYS, and AUTOEXEC.BAT, etc. will be changed.
5. Follow the procedures displayed on your screen until the completion message appears.
6. Eject the floppy disk from the floppy disk drive.
After the installation, keep this floppy disk for future use.
7. To restart the system, press the reset button on your personal computer, or the following keys:



Check that the device driver of this equipment has been installed during the start-up procedure.

Every time DOS is started, the device driver of this equipment will be automatically installed. If you have installed only the device driver for Windows, you do not need to restart the system.

Weight and dimensions shown are approximate.
Specifications are subject to change without notice.

LMQT00541

Created in Japan

Rev. A