

**MATSUSHITA-KOTOBUKI  
ELECTRONICS INDUSTRIES LTD.**

MATSUYAMA DIVISION

2131-1 Minamikata, Kawauchi-cho, Onsen-gun, Ehime-ken, 791-0395 Japan

PHONE +81 89 966 2111 FAX +81 89 966 2123

Page 1 of 18 pages

# **TEST REPORT**

---

REPORT NUMBER : MKM01F-009

APPLICANT : Matsushita-Kotobuki  
Electronics Industries, Ltd.

MODEL NUMBER : CW-8571-B

FCC ID : IUO9TB091CRB

Regulation : FCC Part15B Class B

Conducted Emission Test  
Radiated Emission Test

Matsushita-Kotobuki Electronics Ind., Ltd.  
Matsuyama Division

2131-1 Minamikata, Kawauchi-cho, Onsen-gun,  
Ehime-ken, 791-0395 Japan  
Tel.: +81 89 966 2111 Fax.: +81 89 966 5733

TABLE OF CONTENTS

---

	Page
SECTION 1. <u>TEST CERTIFICATION</u> .....	3
SECTION 2. <u>EQUIPMENT UNDER TEST</u> .....	5
SECTION 3. <u>SUPPORT EQUIPMENT USED</u> .....	6
SECTION 4. <u>CABLE(S) USED</u> .....	7
SECTION 5. <u>CONSTRUCTION OF EQUIPMENT</u> .....	9
SECTION 6. <u>OPERATING CONDITIONS</u> .....	10
SECTION 7. <u>TEST PROCEDURE(S)</u> .....	11
SECTION 8. <u>EVALUATION OF TEST RESULTS</u> .....	12
SECTION 9. <u>PHOTOGRAPHS OF TEST SET-UP</u> .....	16
SECTION 10. <u>INSTRUMENTS USED FOR TEST</u> .....	17
SECTION 11. <u>PRECISION</u> .....	18
SECTION 12. <u>VALIDITY OF TEST REPORT</u> .....	18

---

SECTION 1. TEST CERTIFICATION

## APPLICANT INFORMATION

Company : Matsushita-Kotobuki Electronics Industries, Ltd.  
Address : 8-1, Furujin-machi, Takamatsu-city, Kagawa-ken,  
760-0025 Japan

## GRANTEE INFORMATION

Company : Matsushita-Kotobuki Electronics Industries, Ltd.  
Division / Section : Matsuyama Division Legal Affairs Sec.  
Address : 2131-1 Minamikata, Kawauchi-cho, Onsen-gun,  
Ehime-ken, 791-0395 Japan  
Telephone number : +81 89 966 2111  
Fax number : +81 89 966 5733  
Contact person : Kenji Matsugi

## DESCRIPTION OF TEST ITEM

Kind of equipment : DVD-ROM & CD-R/RW Drive  
Trademark : Matsushita-Kotobuki  
FCC ID : IUO9TB091CRB  
Model number : CW-8571-B  
Serial number : 1116XXA00010

**TEST PERFORMED**

FCC Registration No.	: 90793
Test started	: February 15, 2001
Test completed	: February 15, 2001
Purpose of test	: FCC Docket 87-389
Regulation	: FCC Part 15B Class B Unintentional Radiators
Test setup	: ANSI C63.4 -1992

Report file number : MKM01F-009

Report issue date : February 15, 2001

Test engineer : Shinji Yamauchi

S. Yamauchi

Report approved by : Hisayuki Honda

H. Honda

[ Manager ]

This equipment complies with above standard or regulation under the test condition or test configuration shown on this test report.

## SECTION 2. EQUIPMENT UNDER TEST

The equipment under test (EUT) consists of the following equipment.

Indication in the following left side column corresponds to section 5.

Symbol	Item	Model No.	Serial No.	FCC ID	Manufacturer
A)	DVD-ROM & CD-R/RW Drive	CW-8571-B	1116XXA00010	IUO9TB091CRB	Matsushita-Kotobuki Electronics Ind., Ltd.

Power ratings of EUT : +5V DC, 1.0A / +12V DC, 2.0A

### 2.1 Port(s) / Connector(s) :

IDE Bus Connector(40pin), Head Phone Jack(Stereo Mini Plug),  
Audio Out Connector(4pin), Digital Audio Out Connector(2pin), DC IN Connector(4pin)

### 2.2 Oscillator(s) / Crystal(s) :

Oscillator	Operating Frequency	Board name	Remarks
33.86 MHz	45.16 MHz	Main PCB	Optical Disc Controller
33.86 MHz	45.16 MHz	Main PCB	CPU
300 MHz / typ.	300 MHz / typ.	Pick Up	High Frequency Module (CD)
400 MHz / typ.	400 MHz / typ.	Pick Up	High Frequency Module (DVD)

### SECTION 3. SUPPORT EQUIPMENT USED

The EUT has been supported by the following equipment during these tests. Indication in the following left side column corresponds to section 5.

Symbol	Item	Model No.	Serial No.	FCC ID	Manufacturer
B)	Interface Card	LMEP0345A	None	IUO9TB035CRI	Matsushita-Kotobuki
C)	Host Computer	OptiPlex GXa DCS	SPHWX	Declaration of Conformity	DELL
D)	Head Phone	RP-HT28	None	N.A.	Panasonic
E)	Stereo Radio Cassette Recorder	RX-F5	None	ACJ9TBRX-F5	Panasonic
F)	Keyboard	SK-1000REW	M970911905	GYUR36SK	DELL
G)	Color Display	14MVX	5103	ABL9679001CD	HITACHI
H)	Printer	3630A	3219A17397	BSD8533630A	HEWLETT PACKARD
I)	Modem	C202A	010489	BKM552C202A	EPSON
J)	Mouse	M-S34-6MD	ID75BCIF1MON	DZL211029	COMPAQ

SECTION 4. CABLE(S) USED

The following cable(s) was used for testing. Indication number in the following left side column corresponds to section 5.

Number	Name	Length	Shield	From	To
1)	40Pin Flat cable	0.4 m	None	DVD-ROM Drive Plastic connector	Host Computer
2)	Audio cable	0.4 m	None	DVD-ROM Drive Plastic connector	Interface Card
3)	Digital Audio cable	0.4 m	None	DVD-ROM Drive Plastic connector	Interface Card
4)	DC Power cable	0.4 m	None	DVD-ROM Drive	Host Computer
5)	Head Phone cable	1.5 m	None	DVD-ROM Drive Plastic connector	Head Phone
6)	Audio cable	1.0 m	None	Interface Card	Stereo Radio Cassette Recorder
7)	Audio cable	1.0 m	None	Interface Card	Stereo Radio Cassette Recorder
8)	Keyboard I/F cable	1.9 m	Yes	Host Computer Metal connector	Keyboard
9)	Video Signal I/F cable	1.4 m	Yes	Host Computer Metal connector	Color Display

None :

All cables are not attached ferrite core.

The following cable(s) was used for testing. Indication number in the following left side column corresponds to section 5.

Number	Name	Length	Shield	From	To
10)	Mouse cable	1.8 m	None	Host Computer Metal connector	Mouse
11)	Parallel I/F cable	1.5 m	Yes	Host Computer Metal connector	Printer
12)	RS-232C I/F cable	1.1 m	Yes	Host Computer Metal connector	Modem
13)	Power cord for Host Computer	1.9 m	Yes	Host Computer	Power Source
14)	Power cord for Stereo Radio Cassette Recorder	1.9 m	None	Stereo Radio Cassette Recorder	Power Source
15)	Power cord for Color Display	1.9 m	None	Color Display	Power Source
16)	Power cord for Printer	2.0 m	None	Printer	AC Adapter
17)	Power cord for Printer	2.0 m	None	AC Adapter	Power Source
18)	Power cord for Modem	1.9 m	None	Modem	Power Source

None :

All cables are not attached ferrite core.



**SECTION 5. CONSTRUCTION OF EQUIPMENT**

The construction of EUT during testing is as follows.

System configuration

\*: EUT

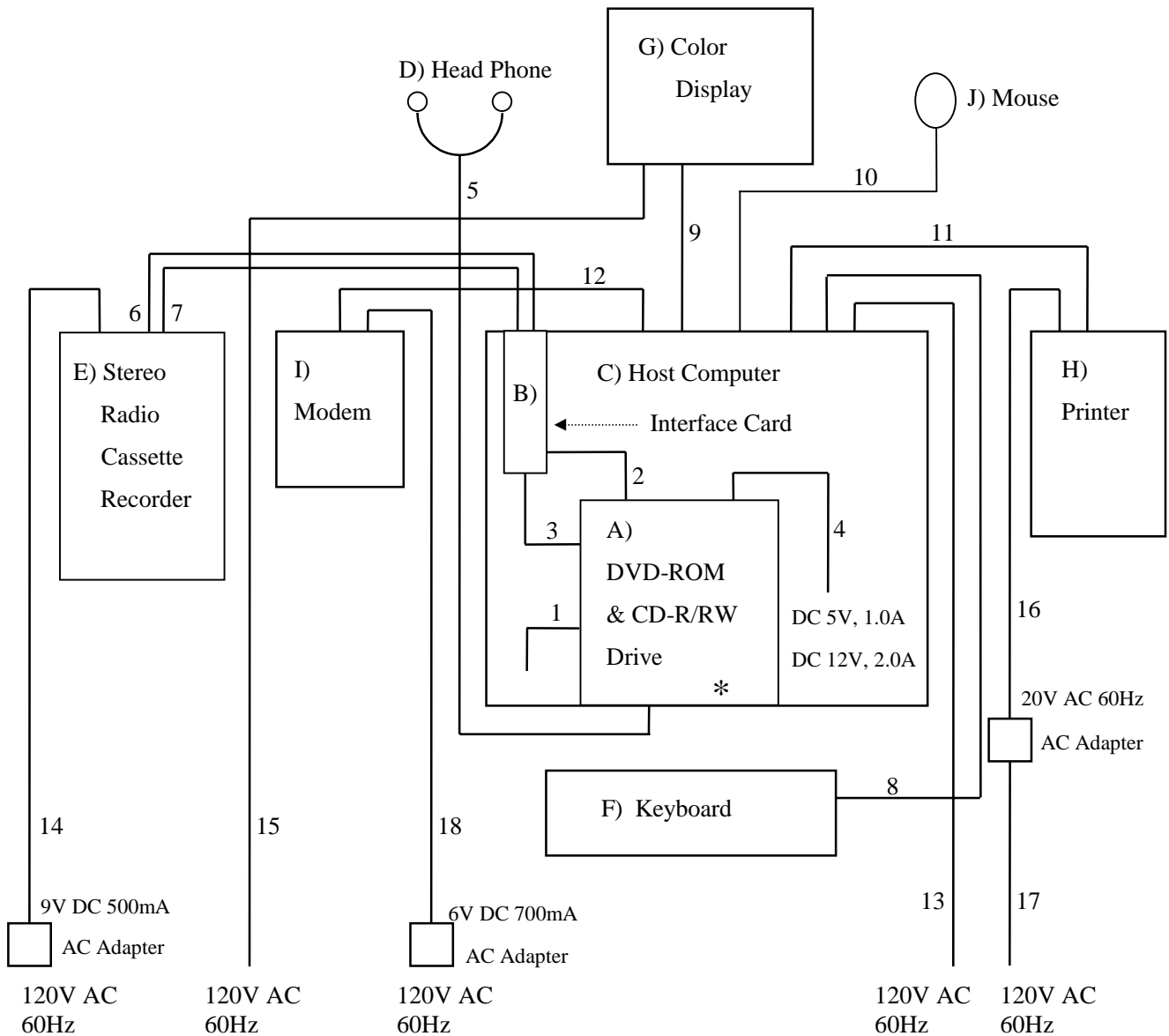

Symbol or numbers assigned to equipment or cables on this diagram are corresponded to the symbols or numbers assigned to equipment or cables on tables in Sections 2 to 4.

## SECTION 6. OPERATING CONDITIONS

The EUT has been operated under the following conditions during the tests.

### 6.1 Operating condition

The tests have been carried out under Read mode.

### 6.2 Operation flow

Performed following operations continuously.

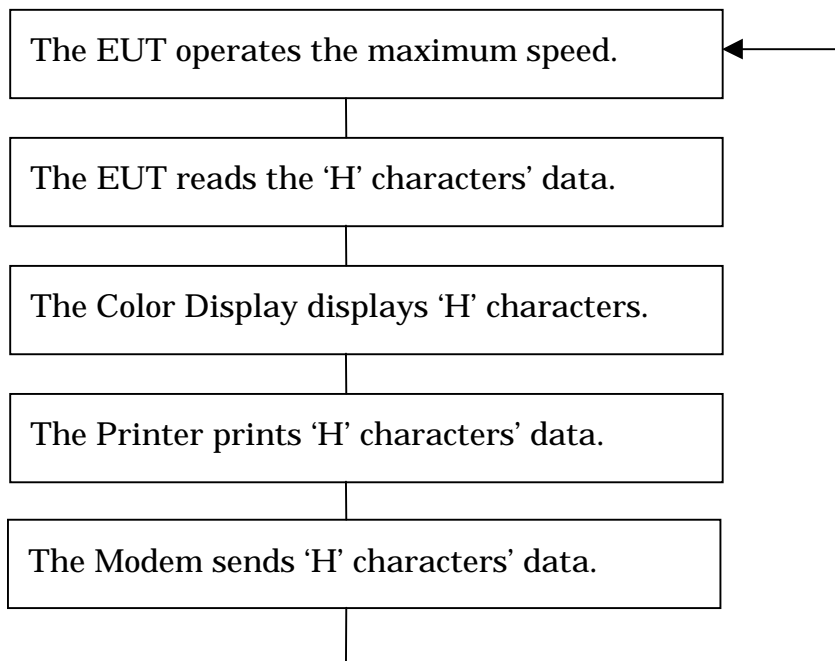

**SECTION 7. TEST PROCEDURE(S)**

Tests have been carried out with the test procedure(s) drawn up by our laboratory which is in accordance with the following test procedure(s).

Test item	Test procedure used	Scanned frequency range
Conducted Emission	ANSI C63.4-1992	0.45 - 30 MHz
Radiated Emission	ANSI C63.4-1992	30 - 2000 MHz

## SECTION 8. EVALUATION OF TEST RESULTS

### 8.1 Conducted Emission Test

Product Name	: DVD-ROM & CD-R/RW Drive
Model No.	: CW-8571-B
Serial No.	: 1116XXA00010
Power Supply	: 120V / 60Hz
Test Mode	: DVD-ROM Read mode
Temp / Humi / Pres	: 15 °C / 33% / 1015hPa
Operator	: S. Yamauchi

No	Freq. [ MHz ]	Reading Level		Factor [ dB ]	Emission Level		Limit [ dBuV ]	Margin [ dB ]
		Va [ dBuV ]	Vb		Va [ MHz ]	Vb		
1	0.853	----	39.1	0.1	----	39.2	48.0	8.8
2	1.136	40.0	----	0.1	40.1	----	48.0	7.9
3	1.234	----	40.0	0.2	----	40.2	48.0	7.8
4	2.561	----	34.1	0.2	----	34.3	48.0	13.7
5	2.648	34.9	----	0.2	35.1	----	48.0	12.9
6	6.287	----	32.5	0.3	----	32.8	48.0	15.2
7	6.287	32.5	----	0.3	32.8	----	48.0	15.2
8	18.810	25.7	----	0.9	26.6	----	48.0	21.4

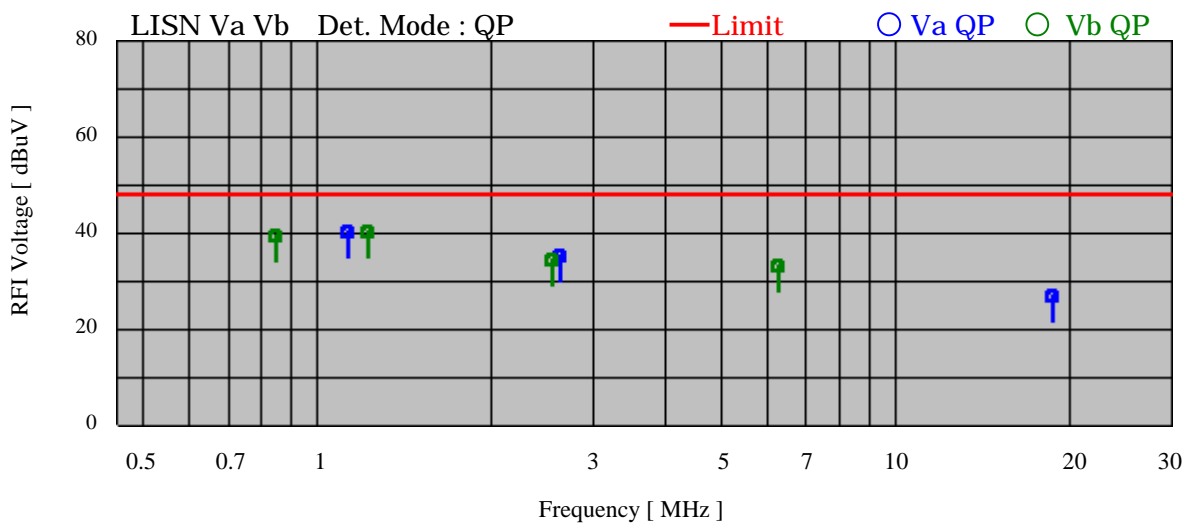

### 8.2 Radiated Emission Test

Product Name	: DVD-ROM & CD-R/RW Drive
Model No.	: CW-8571-B
Serial No.	: 1116XXA00010
Power Supply	: 120V / 60Hz
Test Mode	: DVD-ROM Read mode
Temp / Humi / Pres	: 15 °C / 33% / 1015hPa
Operator	: S. Yamauchi

[ Quasi Peak mode ]

No	Freq. [ MHz ]	Reading Level [ dBuV ]		Factor [ dB ]	Emission Level [ dBuV/m ]		Limit [ dBuV/m ]	Margin [ dB ]
		Hor.	Ver.		Hor.	Ver.		
1	36.003	----	10.4	18.4	----	28.8	40.0	11.2
2	140.030	7.4	----	16.2	23.6	----	43.5	19.9
3	144.032	13.4	----	16.3	29.7	----	43.5	13.8
4	313.128	21.3	----	20.0	41.3	----	46.0	4.7
5	313.215	----	14.6	20.0	----	34.6	46.0	11.4
6	403.398	----	14.7	20.4	----	35.1	46.0	10.9
7	403.456	13.6	----	20.4	34.0	----	46.0	12.0
8	576.517	----	7.2	24.0	----	31.2	46.0	14.8
9	576.518	7.3	----	24.0	31.3	----	46.0	14.7
10	626.477	----	8.8	25.0	----	33.8	46.0	12.2
11	627.367	2.8	----	25.7	27.8	----	46.0	18.2
12	644.354	----	10.5	25.3	----	35.8	46.0	10.2
13	806.692	----	8.3	27.1	----	35.4	46.0	10.6
14	939.400	----	5.6	28.8	----	35.4	46.0	11.6
15	949.545	4.1	----	29.1	33.2	----	46.0	12.8

[ Peak mode ]

No	Freq. [ MHz ]	Reading Level [ dBuV ]		Factor [ dB ]	Emission Level [ dBuV/m ]		Limit [ dBuV/m ]	Margin [ dB ]
		Hor.	Ver.		Hor.	Ver.		
1	1213	----	15.6	29.4	----	45.0	54.0	9.0
2	1390	----	13.8	30.2	----	44.0	54.0	10.0

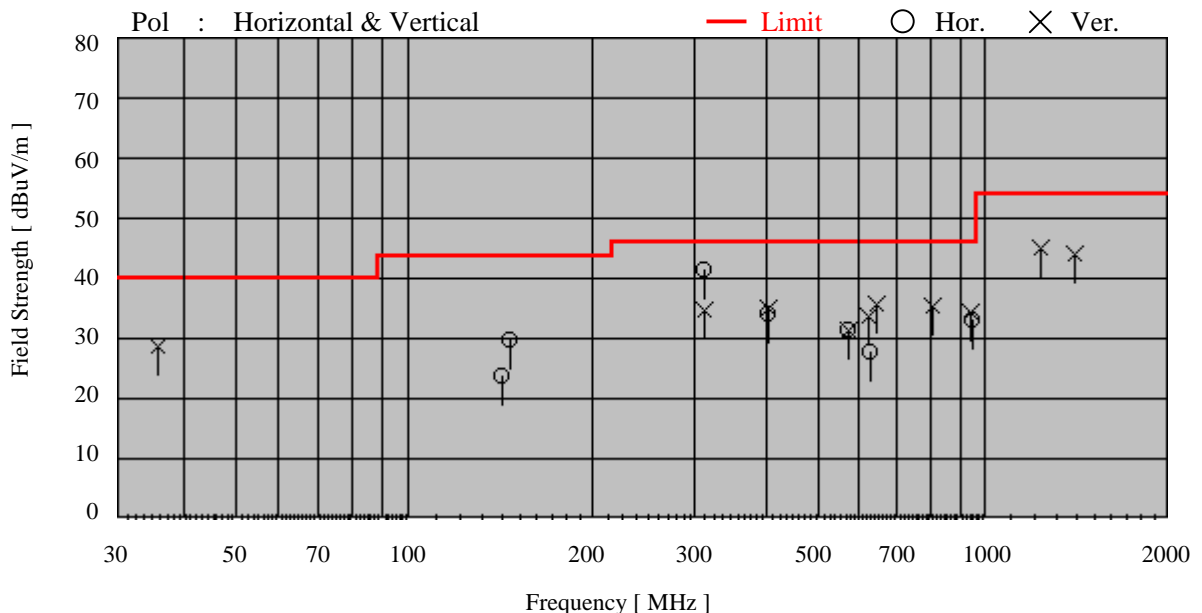

### 8.3 Conclusion

This test report clearly shows that the EUT is in compliance with the FCC Part 15B, Class B specification.

The minimum margins to the limits are as follows:

Conduction measurement	7.8 dB	at	1.234 MHz
Radiation measurement	4.7 dB	at	313.128 MHz

## 8.4 Sample Calculations

### 8.4.1 Conducted Emission

Example @ 1.234 MHz

$$\begin{array}{rcl}
 \text{Emission Level} & = & \text{Meter Reading} & 40.0 \text{ dBuV} \\
 & & + \text{ A.M.N. Factor} & + 0.2 \text{ dB} \\
 & & & \hline
 & & = & 40.2 \text{ dBuV}
 \end{array}$$

$$\begin{array}{rcl}
 \text{Margin} & = & \text{Limit} & 48.0 \text{ dBuV} \\
 & & - \text{ Emission Level} & - 40.2 \text{ dBuV} \\
 & & & \hline
 & & = & 7.8 \text{ dB}
 \end{array}$$

A.M.N. : Artificial Mains Network = Line Impedance Stabilization Network (LISN)

### 8.4.2 Radiated Emission

Example @ 313.128 MHz

$$\begin{array}{rcl}
 \text{Emission Level} & = & \text{Meter Reading} & 21.3 \text{ dBuV} \\
 & & + \text{ Factor} & + 20.0 \text{ dB} \\
 & & & \hline
 \text{( Factor = Antenna Factor + Cable Loss )} & & & = 41.3 \text{ dBuV/m}
 \end{array}$$

$$\begin{array}{rcl}
 \text{Margin} & = & \text{Limit} & 46.0 \text{ dBuV/m} \\
 & & - \text{ Emission Level} & - 41.3 \text{ dBuV/m} \\
 & & & \hline
 & & = & 4.7 \text{ dB}
 \end{array}$$

## SECTION 9. PHOTOGRAPHS OF TEST SET-UP

### Test setup in accordance with ANSI C63.4-1992

#### 9.1 Conducted Emission Test



Front View



Rear view

#### 9.2 Radiated Emission Test



Front View



Rear view

Note : Maintaining 10cm spacing between all the equipment cabinets.



SECTION 10. INSTRUMENTS USED FOR TEST

Instrument	Model No.	Serial No.	Manufacturer	Last cal.	Period
EMI Test Receiver	85462A	3520A00241	Hewlett Packard	8/2000	1 Year
RF Filter Section	85460A	3448A00210	Hewlett Packard	8/2000	1 Year
Biconical Antenna	BBA9106	None	Schwarzbeck	3/2000	1 Year
Logperiodic Antenna	UHALP9107	1623	Schwarzbeck	3/2000	1 Year
Double Ridged Antenna	3115	9702-5139	EMCO	7/2000	1 Year
Artificial Mains Network(AMN) = Line Impedance Stabilization Network(LISN)					
	ESH3-Z5	840062/024	Schwarzbeck	7/2000	1 Year
Artificial Mains Network(AMN) = Line Impedance Stabilization Network(LISN)					
	ESH3-Z5	840062/028	Schwarzbeck	8/2000	1 Year

## SECTION 11. PRECISION

Tolerances of the measuring instruments are shown on below.

1. Antenna factor  $\pm 2.0$  dB
2. Cable loss  $\pm 1.0$  dB
3. EMI test receiver  $\pm 2.0$  dB
4. Artificial Mains Network(AMN) impedance  $\pm 20\%$   
= Line Impedance Stabilization Network(LISN)
5. Site Attenuation  $\pm 4.0$  dB

Repeatability and reproducibility about maximum emission setup are not specified herein.

## SECTION 12. VALIDITY TEST REPORT

- 12.1 The test result of this report is effective for equipment under test itself and under the test configuration described on the report.
- 12.2 This test report does not assure that whether the test result taken in other testing laboratory is compatible or reproducible to the test result on this report or not.
- 12.3 Copying of this report without permission is prohibited.