

## FCC 47 CFR PART 15 SUBPART C

Product Type : Notebook computer  
Applicant : MilDef Crete Inc.  
Address : 7F, No. 250, Sec.3, Peishen Rd., Shenkeng District, New Taipei City, Taiwan  
Trade Name : MilDef Crete Inc.  
Model Number : DT10  
Test Specification : FCC 47 CFR PART 15 SUBPART C: Oct., 2013  
ANSI C63.4:2009  
Receive Date : Aug. 07, 2014  
Test Period : Aug. 11 ~ Aug. 22, 2014  
Issue Date : Sep. 03, 2014

### Issue by

A Test Lab Techno Corp.  
No. 140-1, Changan Street, Bade City,  
Taoyuan County 334, Taiwan R.O.C.  
Tel : +886-3-2710188 / Fax : +886-3-2710190



Taiwan Accreditation Foundation accreditation number: 1330

**Note:** This report shall not be reproduced except in full, without the written approval of A Test Lab Techno Corp. This document may be altered or revised by A Test Lab Techno Corp. personnel only, and shall be noted in the revision section of the document. The client should not use it to claim product endorsement by TAF, or any government agencies. The test results in the report only apply to the tested sample.

**Revision History**

Rev.	Issue Date	Revisions	Revised By
00	Sep. 03, 2014	Initial Issue	

## Verification of Compliance

Issued Date: 09/03/2014

Product Type : Notebook computer  
Applicant : MilDef Crete Inc.  
Address : 7F, No. 250, Sec.3, Peishen Rd., Shenkeng District, New Taipei City, Taiwan  
Trade Name : MilDef Crete Inc.  
Model Number : DT10  
FCC ID : IR5DT10  
EUT Rated Voltage : DC 12~32V, 7A  
Test Voltage : 120 Vac / 60 Hz  
Applicable Standard : FCC 47 CFR PART 15 SUBPART C: Oct., 2013  
ANSI C63.4:2009  
Test Result : Complied  
Performing Lab. : A Test Lab Techno Corp.

No. 140-1, Changan Street, Bade City,  
Taoyuan County 334, Taiwan R.O.C.

Tel : +886-3-2710188 / Fax : +886-3-2710190

Taiwan Accreditation Foundation accreditation number: 1330

<http://www.atl-lab.com.tw/e-index.htm>



The above equipment was tested by A Test Lab Techno Corp. The test data, data evaluation, test procedures, and equipment configurations shown in this report were made in accordance with the procedures given in ANSI C63.4: 2009 and the energy emitted by the sample tested as described in this report is in compliance with the requirements of FCC Rules Part 15.207, 15.209, 15.247 .

The test results of this report relate only to the tested sample identified in this report.

Approved By

Fly Lu

(Manager)

(Fly Lu)

Reviewed By

Eric Ou Yang

(Testing Engineer)

(Eric Ou Yang)

## TABLE OF CONTENTS

<b>1</b>	<b>General Information.....</b>	<b>6</b>
	1.1. Summary of Test Result .....	6
	1.2. Measurement Uncertainty .....	6
<b>2</b>	<b>EUT Description .....</b>	<b>7</b>
<b>3</b>	<b>Test Methodology .....</b>	<b>8</b>
	3.1. Mode of Operation .....	8
	3.2. EUT Exercise Software .....	8
	3.3. Configuration of Test System Details .....	9
	3.4. Test Site Environment .....	9
<b>4</b>	<b>Maximum Conducted Output Power Measurement .....</b>	<b>10</b>
	4.1. Limit.....	10
	4.2. Test Setup .....	10
	4.3. Test Instruments .....	10
	4.4. Test Procedure .....	10
	4.5. Test Result .....	11
<b>5</b>	<b>Conducted Emission Measurement.....</b>	<b>13</b>
	5.1. Limit.....	13
	5.2. Test Instruments.....	13
	5.3. Test Setup .....	13
	5.4. Test Procedure .....	14
	5.5. Test Result .....	15
<b>6</b>	<b>Radiated Interference Measurement.....</b>	<b>17</b>
	6.1. Limit.....	17
	6.2. Test Instruments.....	17
	6.3. Setup.....	18
	6.4. Test Procedure .....	19
	6.5. Test Result .....	20
<b>7</b>	<b>20dB RF Bandwidth and 99 % Occupied Bandwidth Measurement.....</b>	<b>24</b>
	7.1. Limit.....	24
	7.2. Test Setup .....	24
	7.3. Test Instruments.....	24
	7.4. Test Procedure .....	24
	7.5. Test Result .....	26
	7.6. Test Graphs.....	27

<b>8</b>	<b>Carrier Frequency Separation Measurement</b> .....	<b>29</b>
	8.1. Limit.....	29
	8.2. Test Setup .....	29
	8.3. Test Instruments.....	29
	8.4. Test Procedure .....	29
	8.5. Test Result .....	30
	8.6. Test Graphs.....	31
<b>9</b>	<b>Number of Hopping Measurement</b> .....	<b>33</b>
	9.1. Limit.....	33
	9.2. Test Setup .....	33
	9.3. Test Instruments.....	33
	9.4. Test Procedure .....	33
	9.5. Test Result .....	34
	9.6. Test Graphs.....	35
<b>10</b>	<b>Time of Occupancy (Dwell Time) Measurement</b> .....	<b>37</b>
	10.1. Limit.....	37
	10.2. Test Setup .....	37
	10.3. Test Instruments.....	37
	10.4. Test Procedure .....	37
	10.5. Test Result .....	38
	10.6. Test Graphs.....	40
<b>11</b>	<b>Out of Band Conducted Emissions Measurement</b> .....	<b>42</b>
	11.1. Limit.....	42
	11.2. Test Setup .....	42
	11.3. Test Instruments.....	42
	11.4. Test Procedure .....	42
	11.5. Test Graphs.....	43
<b>12</b>	<b>Band Edges Measurement</b> .....	<b>47</b>
	12.1. Limit.....	47
	12.2. Test Setup .....	47
	12.3. Test Instruments.....	47
	12.4. Test Procedure .....	48
	12.5. Test Result .....	49
<b>13</b>	<b>Antenna Measurement</b> .....	<b>52</b>
	13.1. Limit.....	52
	13.2. Antenna Connector Construction.....	52

## 1 General Information

### 1.1. Summary of Test Result

Standard	Item	Result	Remark
15.247			
15.207	AC Power Conducted Emission	PASS	-----
Standard	Item	Result	Remark
15.247			
15.247(b)(1)	Max. Output Power	PASS	-----
15.247(d)	Transmitter Radiated Emissions	PASS	-----
15.247(a)(1)	20dB RF Bandwidth	PASS	-----
15.247(a)(1)	Carrier Frequency Separation	PASS	-----
15.247(a)(1)(iii)	Number of Hopping	PASS	-----
15.247(a)(1)(iii)	Time of Occupancy (Dwell Time)	PASS	-----
15.247(d)	Out of Band Conducted Spurious Emission	PASS	-----
15.247(d)	Band Edge Measurement	PASS	-----
-	Occupied Bandwidth Measurement	PASS	-----
15.203	Antenna Requirement	PASS	-----

The test results of this report relate only to the tested sample(s) identified in this report. Manufacturer or whom it may concern should recognize the pass or fail of the test result.

### 1.2. Measurement Uncertainty

Test Item	Frequency Range	Uncertainty (dB)	
Conducted Emission	9kHz ~ 30MHz	± 2.02	
Radiated Emission	30MHz ~ 1000MHz	Horizontal	± 3.98
		Vertical	± 3.62
	1000MHz ~ 18000MHz	Horizontal	± 3.11
		Vertical	± 3.07
	18000MHz ~ 40000MHz	Horizontal	± 3.66
		Vertical	± 3.54

## 2 EUT Description

Product	Notebook computer		
Trade Name	MilDef Crete Inc.		
Model Number	DT10		
Applicant	MilDef Crete Inc. 7F, No. 250, Sec.3, Peishen Rd., Shengkeng District, New Taipei City, Taiwan		
Manufacturer	MilDef Crete Inc. 7F, No. 250, Sec.3, Peishen Rd., Shengkeng District, New Taipei City, Taiwan		
FCC ID	IR5DT10		
Frequency Range	2402 ~ 2480 MHz		
Modulation Type	GFSK for 1Mbps		
	$\pi/4$ -DQPSK for 2Mbps		
	8DPSK for 3Mbps		
Antenna Type	PIFA Antenna		
Antenna Gain	1.81 dBi		
RF Output Power (Conducted)	GFSK for 1Mbps	7.18 dBm /	0.005 W
	$\pi/4$ -DQPSK for 2Mbps	5.95 dBm /	0.004 W
	8DPSK for 3Mbps	6.23 dBm /	0.004 W
99 % Occupied Bandwidth	GFSK: 0.89MHz		
	8DPSK: 1.18MHz		

### 3 Test Methodology

#### 3.1. Mode of Operation

Decision of Test ATL has verified the construction and function in typical operation. All the test modes were carried out with the EUT in normal operation, which was shown in this test report and defined as:

Test Mode
Mode 1: Normal Operation Mode
Mode 2: GFSK Link Mode
Mode 3: $\pi/4$ -DQPSK Link Mode
Mode 4: 8DPSK Link Mode

By preliminary testing and verifying three axis (X, Y and Z) position of EUT transmitted status, it was found that "X axis" position was the worst, then the final test was executed the worst condition and test data were recorded in this report.

##### Description of Test Modes

Preliminary tests were performed in different modulation to find the worst case. The modulation has shown the worst-case in section 6.5. Investigation has been done on all the possible configurations for searching the worst cases.

##### Tested System Details

The types for all equipments, plus descriptions of all cables used in the tested system (including inserted cards) are:

	Product	Manufacturer	Model Number	Serial Number	Power Cord
1.	Bluetooth Tester	R & S	CBT	100350	NA

#### 3.2. EUT Exercise Software

1	Setup the EUT and Bluetooth Tester (CBT) as shown on 3.3.
2	Turn on the power of all equipment.
3	EUT run test program.
4	Open Bluetooth function link to CBT.



### 3.3. Configuration of Test System Details

#### Conducted Emissions

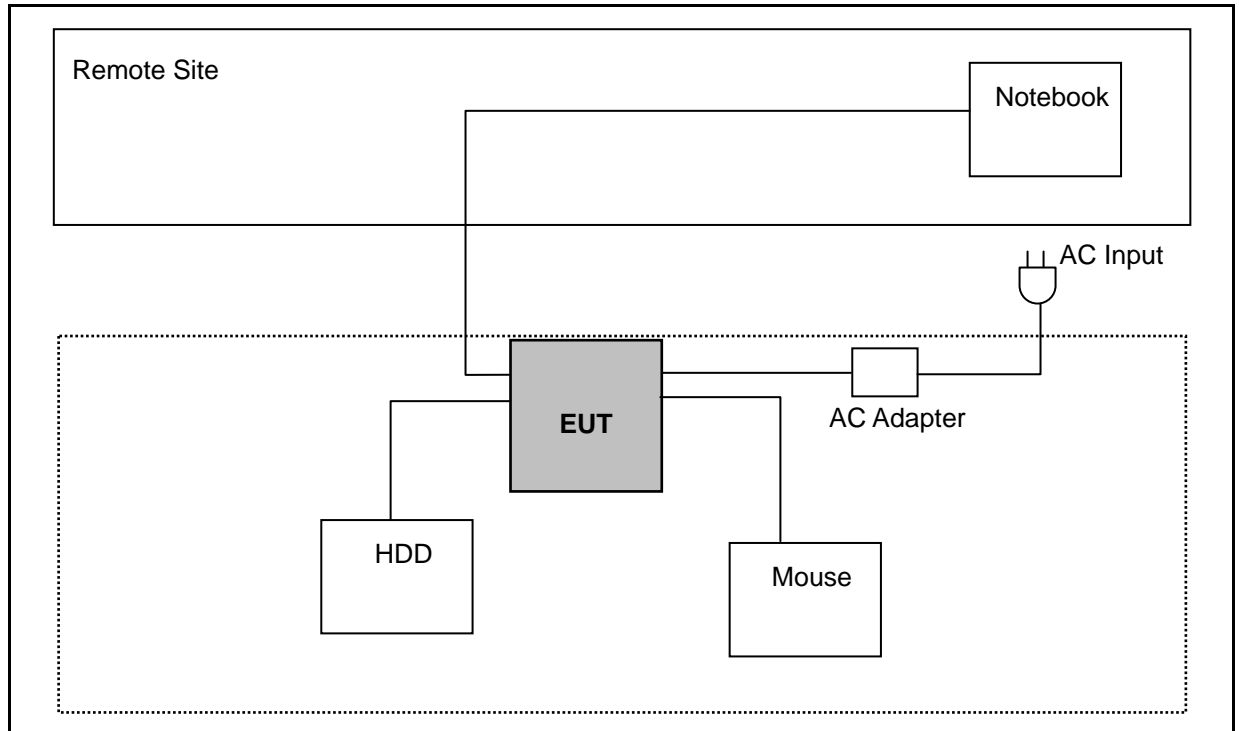

#### Radiated Emissions

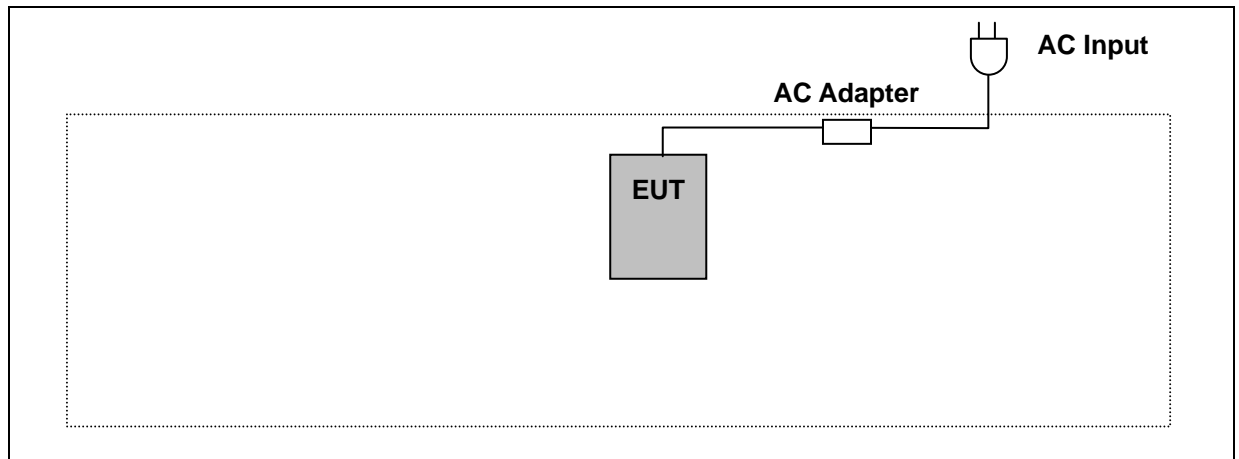

### 3.4. Test Site Environment

Items	Required (IEC 60068-1)	Actual
Temperature (°C)	15-35	26
Humidity (%RH)	25-75	60
Barometric pressure (mbar)	860-1060	950

## 4 Maximum Conducted Output Power Measurement

### 4.1. Limit

For frequency hopping systems operating in the 2400–2483.5 MHz band employing at least 75 non-overlapping hopping channels < 0.125 watt.

### 4.2. Test Setup

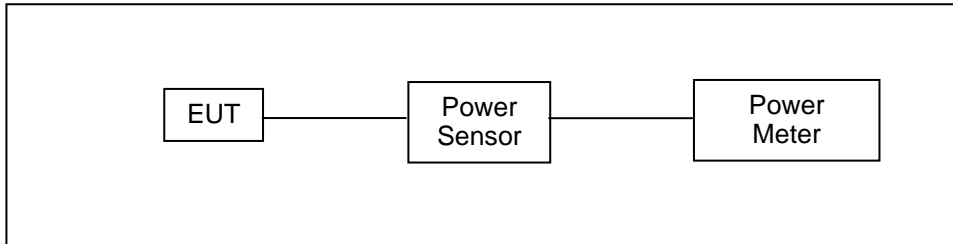

### 4.3. Test Instruments

Equipment	Manufacturer	Model Number	Serial Number	Cal. Date	Remark
Single Channel PK Power Sensor	Agilent	N1911A	MY45101619	12/21/2013	(1)
Wideband Power Meter	Agilent	N1921A	MY45241957	12/21/2013	(1)
Test Site	ATL	TE02	TE02	N.C.R.	-----

Remark: (1) Calibration period 1 year. (2) Calibration period 2 years.

NOTE: N.C.R. = No Calibration Request.

### 4.4. Test Procedure

Testing must be done according to this procedure, FCC Public Notice DA 00-705 - Filing and Measurement Guidelines for Frequency Hopping Spread Spectrum Systems. This is the only method recognized by the FCC. The tests below are run with the EUT's transmitter set at high power in TX mode. The EUT is needed to force selection of output power level and channel number. While testing, EUT was set to transmit continuously. Remove the Subjective device's antenna and connect the RF output port to power sensor. The maximum peak output power shall not exceed 1 watt.

Use a direct connection between the antenna port of transmitter and the power sensor, for prevent the power sensor input attenuation 40-50 dB. Set the RBW Bandwidth of the emission or use a channel power meter mode. For antennas with gains of 6 dBi or less, maximum allowed transmitter output is 1 watt (+30 dBm). For antennas with gains greater than 6 dBi, transmitter output level must be decreased by an amount equal to (GAIN - 6)/3 dBm. The antenna port of the EUT was connected to the input of a power sensor. Power was read directly and cable loss correction was added to the reading to obtain power at the EUT antenna terminals.

**4.5. Test Result**

Model Number	DT10					
Test Item	Maximum Conducted Output Power					
Test Mode	Mode 3: GFSK Link Mode					
Date of Test	08/11/2014			Test Site	TE02	
Frequency (MHz)	Packet Type	Average Power		Peak Power		Limit (mW)
		(dBm)	(W)	(dBm)	(W)	
2402	DH1	4.04	0.00254	6.45	0.00442	< 125
	DH3	5.49	0.00354	6.40	0.00437	< 125
	DH5	5.72	0.00373	6.43	0.00440	< 125
2441	DH1	3.23	0.00210	5.58	0.00361	< 125
	DH3	4.71	0.00296	5.58	0.00361	< 125
	DH5	4.93	0.00311	5.57	0.00361	< 125
2480	DH1	4.88	0.00308	7.14	0.00518	< 125
	DH3	6.33	0.00430	7.16	0.00520	< 125
	DH5	6.56	0.00453	<b>7.18</b>	<b>0.00522</b>	< 125

Model Number	DT10					
Test Item	Maximum Conducted Output Power					
Test Mode	Mode 4: $\pi/4$ -DQPSK Mode					
Date of Test	08/11/2014			Test Site	TE02	
Frequency (MHz)	Packet Type	Average Power		Peak Power		Limit (mW)
		(dBm)	(W)	(dBm)	(W)	
2402	DH1	-0.10	0.00098	4.14	0.00259	< 125
	DH3	1.00	0.00126	4.28	0.00268	< 125
	DH5	1.18	0.00131	4.23	0.00265	< 125
2441	DH1	-0.22	0.00095	3.95	0.00248	< 125
	DH3	0.87	0.00122	4.05	0.00254	< 125
	DH5	1.04	0.00127	4.03	0.00253	< 125
2480	DH1	2.05	0.00160	5.92	0.00391	< 125
	DH3	3.15	0.00207	5.93	0.00392	< 125
	DH5	3.31	0.00214	<b>5.95</b>	<b>0.00394</b>	< 125

Model Number	DT10					
Test Item	Maximum Conducted Output Power					
Test Mode	Mode 5: 8DPSK Link Mode					
Date of Test	08/11/2014			Test Site	TE02	
Frequency (MHz)	Packet Type	Average Power		Peak Power		Limit (mW)
		(dBm)	(W)	(dBm)	(W)	
2402	DH1	-0.12	0.00097	4.74	0.00298	< 125
	DH3	0.93	0.00124	4.49	0.00281	< 125
	DH5	1.11	0.00129	4.62	0.00290	< 125
2441	DH1	-0.22	0.00095	4.45	0.00279	< 125
	DH3	0.86	0.00122	4.34	0.00272	< 125
	DH5	1.03	0.00127	4.36	0.00273	< 125
2480	DH1	2.06	0.00161	6.20	0.00417	< 125
	DH3	3.13	0.00206	6.21	0.00418	< 125
	DH5	3.32	0.00215	<b>6.23</b>	<b>0.00420</b>	< 125

## 5 Conducted Emission Measurement

### 5.1. Limit

Frequency (MHz)	Quasi-peak	Average
0.15 - 0.5	66 to 56	56 to 46
0.50 - 5.0	56	46
5.0 - 30.0	60	50

### 5.2. Test Instruments

Describe	Manufacturer	Model Number	Serial Number	Cal. Date	Remark
Test Receiver	R&S	ESCI	100367	06/12/2014	(1)
LISN	R&S	ENV216	101040	03/07/2014	(1)
LISN	R&S	ENV216	101041	03/07/2014	(1)
Test Site	ATL	TE05	TE05	N.C.R.	-----

Remark: (1) Calibration period 1 year. (2) Calibration period 2 years.

NOTE: N.C.R. = No Calibration Request.

### 5.3. Test Setup

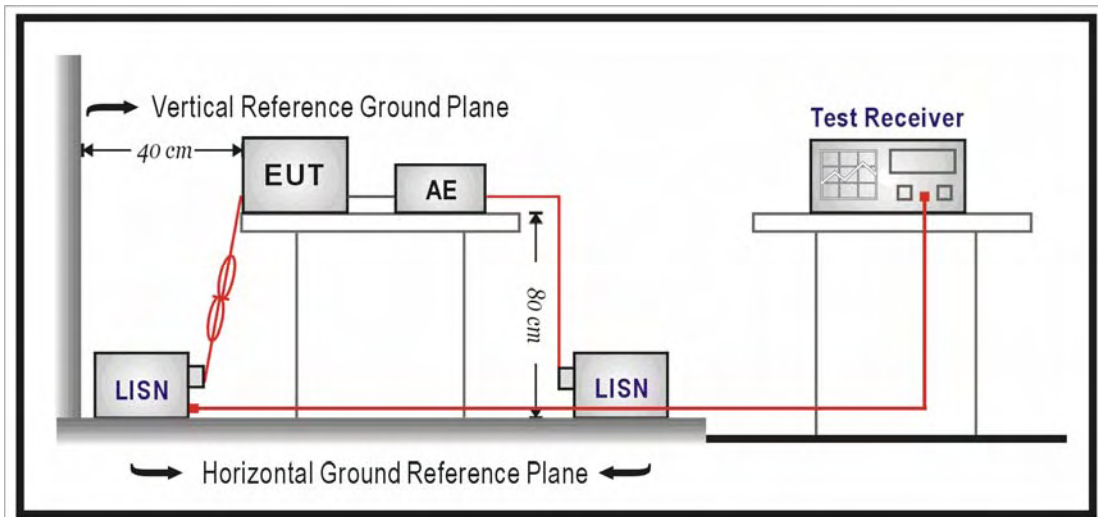

#### **5.4. Test Procedure**

The power line conducted emission measurements were performed in a shielded enclosure. The EUT was assembled on a wooden table which is 80 centimeters high, was placed 40 centimeters from the back wall and at least 1 meter from the sidewall.

Power was fed to the EUT from the public utility power grid through a line filter and EMCO Model 3162/2 SH Line Impedance Stabilization Networks (LISN). The LISN housing, measuring instrumentation case, ground plane, etc., were electrically bonded together at the same RF potential. The Spectrum analyzer was connected to the AC line through an isolation transformer. The 50-ohm output of the LISN was connected to the spectrum analyzer directly. Conducted emission levels were in the CISPR quasi-peak detection mode. The analyzer's 6 dB bandwidth was set to 9 KHz. No post-detector video filter was used.

The spectrum was scanned from 150 KHz to 30 MHz. The physical arrangement of the test system and associated cabling was varied (within the scope of arrangements likely to be encountered in actual use) to determine the effect on the unit's emanations in amplitude and frequency. All spurious emission frequencies were observed. The highest emission amplitudes relative to the appropriate limit were measured and have been recorded in paragraph 4.1.

**5.5. Test Result**

Standard:	FCC Part 15C	Line:	L1
Test item:	Conducted Emission	Power:	AC 120V/60Hz
Model Number:	DT10	Temp.(°C)/Hum.(%RH):	26(°C)/60%RH
Mode:	Mode 1	Date:	08/22/2014
		Test By:	Eric Ou Yang
Description:			

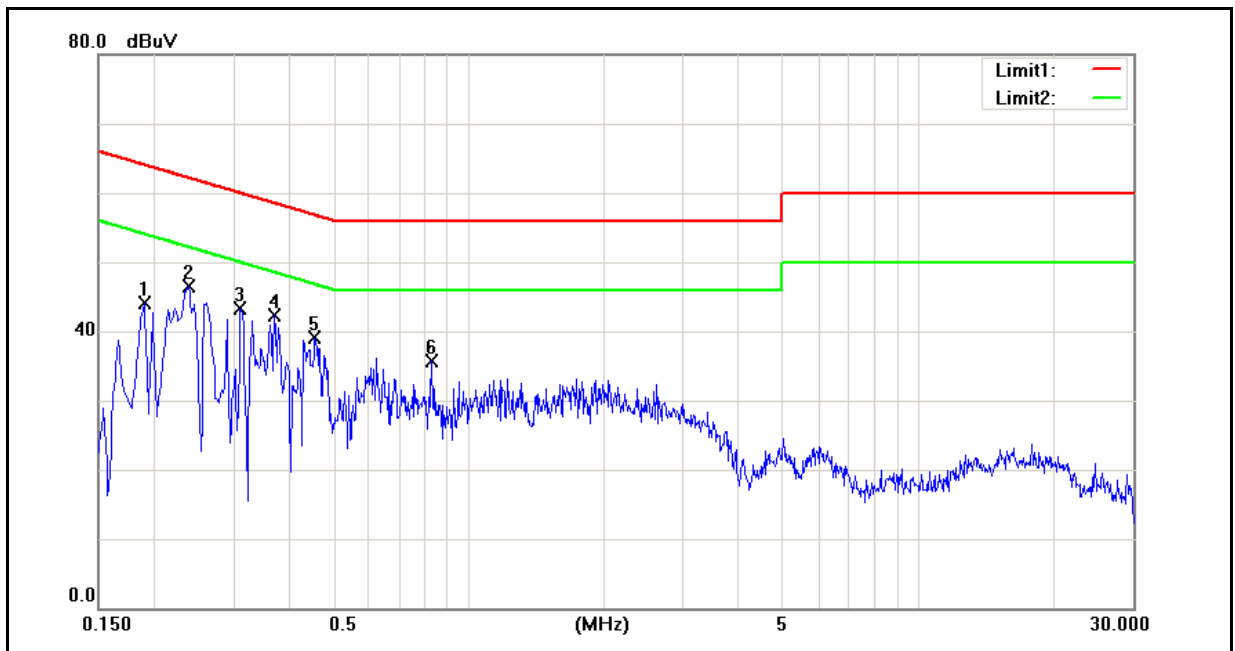

No.	Frequency (MHz)	QP reading (dBuV)	AVG reading (dBuV)	Correction factor (dB)	QP result (dBuV)	AVG result (dBuV)	QP limit (dBuV)	AVG limit (dBuV)	QP margin (dB)	AVG margin (dB)	Remark
1	0.1900	30.70	11.86	9.60	40.30	21.46	64.04	54.04	-23.74	-32.58	Pass
2	0.2380	33.98	19.54	9.60	43.58	29.14	62.17	52.17	-18.59	-23.03	Pass
3	0.3100	25.55	5.67	9.61	35.16	15.28	59.97	49.97	-24.81	-34.69	Pass
4	0.3700	29.26	14.22	9.61	38.87	23.83	58.50	48.50	-19.63	-24.67	Pass
5	0.4540	27.82	14.17	9.62	37.44	23.79	56.80	46.80	-19.36	-23.01	Pass
6	0.8300	21.44	11.60	9.64	31.08	21.24	56.00	46.00	-24.92	-24.76	Pass

Note: 1. Result (dBuV) = Correction factor (dB) + Reading(dBuV).

2. Correction factor (dB) = Cable loss (dB) + L.I.S.N. factor (dB).

Standard:	FCC Part 15C	Line:	N
Test item:	Conducted Emission	Power:	AC 120V/60Hz
Model Number:	DT10	Temp.(°C)/Hum.(%RH):	26(°C)/60%RH
Mode:	Mode 1	Date:	08/22/2014
		Test By:	Eric Ou Yang
Description:			

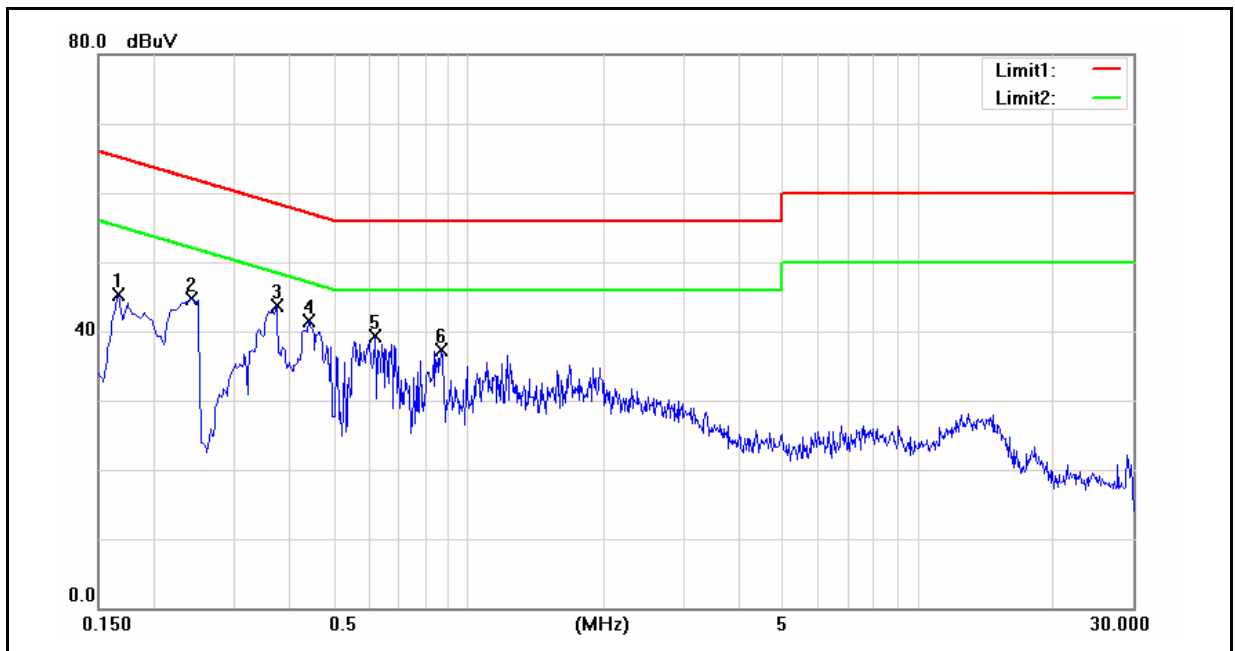

No.	Frequency (MHz)	QP reading (dBuV)	AVG reading (dBuV)	Correction factor (dB)	QP result (dBuV)	AVG result (dBuV)	QP limit (dBuV)	AVG limit (dBuV)	QP margin (dB)	AVG margin (dB)	Remark
1	0.1660	34.47	16.71	9.60	44.07	26.31	65.16	55.16	-21.09	-28.85	Pass
2	0.2420	34.29	18.81	9.60	43.89	28.41	62.03	52.03	-18.14	-23.62	Pass
3	0.3740	27.44	10.99	9.61	37.05	20.60	58.41	48.41	-21.36	-27.81	Pass
4	0.4420	28.15	14.09	9.61	37.76	23.70	57.02	47.02	-19.26	-23.32	Pass
5	0.6180	24.36	10.58	9.62	33.98	20.20	56.00	46.00	-22.02	-25.80	Pass
6	0.8700	22.89	11.30	9.64	32.53	20.94	56.00	46.00	-23.47	-25.06	Pass

Note: 1. Result (dBuV) = Correction factor (dB) + Reading(dBuV).

2. Correction factor (dB) = Cable loss (dB) + L.I.S.N. factor (dB).



## 6 Radiated Interference Measurement

### 6.1. Limit

According to §15.209(a), except as provided elsewhere in this subpart, the emissions from an intentional radiator shall not exceed the field strength levels specified in the following table:

Frequency (MHz)	Field Strength ( $\mu\text{V}/\text{m}$ at meter)	Measurement Distance (meters)
0.009 – 0.490	2400 / F (kHz)	300
0.490 – 1.705	24000 / F (kHz)	30
1.705 – 30.0	30	30
30 - 88	100**	3
88-216	150**	3
216-960	200**	3
Above 960	500	3

\*\* Except as provided in paragraph (g), fundamental emissions from intentional radiators operating under this Section shall not be located in the frequency bands 54-72 MHz, 76-88 MHz, 174-216 MHz or 470-806 MHz. However, operation within these frequency bands is permitted under other sections of this Part, e.g., Sections 15.231 and 15.241.

### 6.2. Test Instruments

3 Meter Chamber					
Equipment	Manufacturer	Model Number	Serial Number	Cal. Date	Remark
RF Pre-selector	Agilent	N9039A	MY46520256	01/10/2014	(1)
Spectrum Analyzer	Agilent	E4446A	MY46180578	01/10/2014	(1)
Pre Amplifier	Agilent	8449B	3008A02237	02/21/2014	(1)
Pre Amplifier	Agilent	8447D	2944A10961	02/21/2014	(1)
Broadband Antenna (30MHz~1GHz)	SCHWARZBECK MESS-ELEKTRONIK	VULB9163	9163-270	07/22/2014	(1)
Horn Antenna (1~18GHz)	SCHWARZBECK MESS-ELEKTRONIK	BBHA9120D	9120D-550	06/11/2014	(1)
Horn Antenna (18~40GHz)	SCHWARZBECK MESS-ELEKTRONIK	BBHA9170	9170-320	06/13/2014	(1)
Loop Antenna	COM-POWER CORPORATION	AL-130	121014	08/14/2012	(3)
Test Site	ATL	TE01	888001	08/28/2013	(1)

Remark: (1) Calibration period 1 year. (2) Calibration period 2 years. (3) Calibration period 3 years.

NOTE: N.C.R. = No Calibration Request.

### 6.3. Setup

Below 1GHz

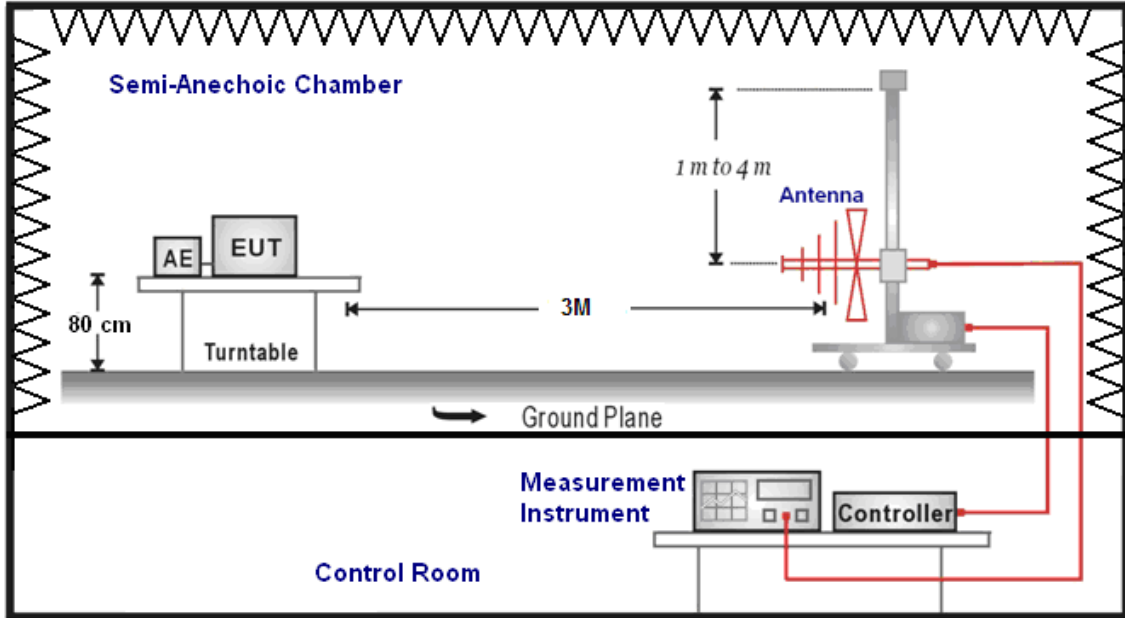

Above 1GHz

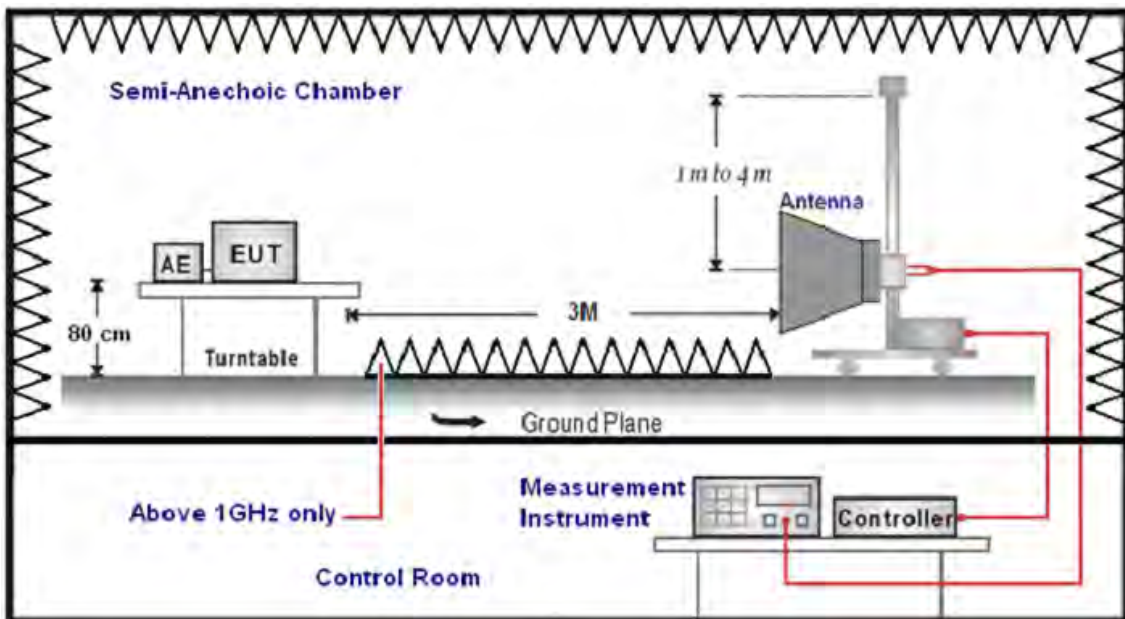

## 6.4. Test Procedure

Final radiation measurements were made on a three-meter, Semi Anechoic Chamber. The EUT system was placed on a nonconductive turntable which is 0.8 meters height, top surface 1.0 x 1.5 meter. The spectrum was examined from 250 MHz to 2.5 GHz in order to cover the whole spectrum below 10th harmonic which could generate from the EUT. During the test, EUT was set to transmit continuously & Measurements spectrum range from 9 kHz to 26.5 GHz is investigated.

For measurements below 1 GHz the resolution bandwidth is set to 100 kHz for peak detection measurements or 120 kHz for quasi-peak detection measurements. Peak detection is used unless otherwise noted as quasi-peak.

For measurements above 1 GHz the resolution bandwidth is set to 1 MHz, and then the video bandwidth is set to 1 MHz for peak measurements and 10 Hz for average measurements.

A nonconductive material surrounded the EUT to supporting the EUT for standing on three orthogonal planes. At each condition, the EUT was rotated 360 degrees, and the antenna was raised and lowered from one to four meters to find the maximum emission levels. Measurements were taken using both horizontal and vertical antenna polarization.

SCHWARZBECK MESS-ELEKTRONIK Biconilog Antenna (model VULB9163) at 3 Meter and the SCHWARZBECK Double Ridged Guide Antenna (model BBHA9120D&9170) was used in frequencies 1 – 26.5 GHz at a distance of 1 meter. All test results were extrapolated to equivalent signal at 3 meters utilizing an inverse linear distance extrapolation Factor (20dB/decade).

For testing above 1GHz, the emission level of the EUT in peak mode was 20dB lower than average limit (that means the emission level in peak mode also complies with the limit in average mode), then testing will be stopped and peak values of EUT will be reported, otherwise, the emissions will be measured in average mode again and reported.

Appropriate preamplifiers were used for improving sensitivity and precautions were taken to avoid overloading or desensitizing the spectrum analyzer. No post – detector video filters were used in the test.

The spectrum analyzer's 6 dB bandwidth was set to 1 MHz, and the analyzer was operated in the peak detection mode, for frequencies both below and up 1 GHz. The average levels were obtained by subtracting the duty cycle correction factor from the peak readings.

The following procedures were used to convert the emission levels measured in decibels referenced to 1 microvolt (dBuV) into field intensity in micro volts per meter (uV/m).

The actual field intensity in decibels referenced to 1 microvolt in to field intensity in micro volts per meter (dBuV/m).

The actual field intensity in decibels referenced to 1 microvolt per meter (dBuV/m) is determined by algebraically adding the measured reading in dBuV, the antenna factor (dB), and cable loss (dB) and Subtracting the gain of preamplifier (dB) is auto calculate in spectrum analyzer.

$$(1) \text{ Amplitude (dBuV/m) = FI (dBuV) +AF (dBuV) +CL (dBuV)-Gain (dB)}$$

FI= Reading of the field intensity.

AF= Antenna factor.

CL= Cable loss.

P.S Amplitude is auto calculate in spectrum analyzer.

$$(2) \text{ Actual Amplitude (dBuV/m) = Amplitude (dBuV)-Dis(dB)}$$

The FCC specified emission limits were calculated according the EUT operating frequency and by following linear interpolation equations:

(a) For fundamental frequency : Transmitter Output < +30dBm

(b) For spurious frequency : Spurious emission limits = fundamental emission limit /10

Data of measurement within this frequency range without mark in the table above means the reading of emissions are attenuated more than 20dB below the permissible limits or the field strength is too small to be measured.

## 6.5. Test Result

### Below 1GHz

Standard:	FCC Part 15C	Test Distance:	3m
Test item:	Radiated Emission	Power:	AC 120V/60Hz
Model Number:	DT10	Temp.(°C)/Hum.(%RH):	26(°C)/60%RH
Mode:	Mode 1	Date:	08/11/2014
		Test By:	Eric Ou Yang

Frequency (MHz)	Reading (dBUV)	Correct Factor (dB/m)	Result (dBUV/m)	Limit (dBUV/m)	Margin (dB)	Remark	Ant.Polar. H / V
131.5000	36.12	-13.18	22.94	43.50	-20.56	QP	H
220.0000	36.59	-13.56	23.03	46.00	-22.97	QP	H
332.5000	38.07	-9.69	28.38	46.00	-17.62	QP	H
520.0000	31.96	-5.95	26.01	46.00	-19.99	QP	H
666.0000	33.17	-3.00	30.17	46.00	-15.83	QP	H
820.5000	27.45	0.12	27.57	46.00	-18.43	QP	H
132.0000	43.14	-13.13	30.01	43.50	-13.49	QP	V
288.0000	48.27	-10.59	37.68	46.00	-8.32	QP	V
396.0000	40.15	-8.29	31.86	46.00	-14.14	QP	V
484.5000	37.91	-6.55	31.36	46.00	-14.64	QP	V
665.0000	36.89	-3.01	33.88	46.00	-12.12	QP	V
940.0000	33.46	2.62	36.08	46.00	-9.92	QP	V

Note: No emission found between lowest internal used/generated frequencies to 30MHz (9 kHz~30MHz).

**Above 1GHz**

Standard:	FCC Part 15C	Test Distance:	3m
Test item:	Radiated Emission	Power:	AC 120V/60Hz
Model Number:	DT10	Temp.(°C)/Hum.(%RH):	26(°C)/60%RH
Mode:	Mode 2	Date:	08/16/2014
Frequency:	2402 MHz	Test By:	Eric Ou Yang

Frequency (MHz)	Reading (dBuV)	Correct Factor (dB/m)	Result (dBuV/m)	Limit (dBuV/m)	Margin (dB)	Remark	Ant.Polar. H / V
3030.000	37.30	-0.11	37.19	74.00	-36.81	peak	H
4563.000	34.27	4.36	38.63	74.00	-35.37	peak	H
6691.000	33.24	10.01	43.25	74.00	-30.75	peak	H
3002.000	37.19	-0.20	36.99	74.00	-37.01	peak	V
4598.000	35.81	4.45	40.26	74.00	-33.74	peak	V
6698.000	33.04	10.03	43.07	74.00	-30.93	peak	V

Standard:	FCC Part 15C	Test Distance:	3m
Test item:	Radiated Emission	Power:	AC 120V/60Hz
Model Number:	DT10	Temp.(°C)/Hum.(%RH):	26(°C)/60%RH
Mode:	Mode 2	Date:	08/16/2014
Frequency:	2441 MHz	Test By:	Eric Ou Yang

Frequency (MHz)	Reading (dBuV)	Correct Factor (dB/m)	Result (dBuV/m)	Limit (dBuV/m)	Margin (dB)	Remark	Ant.Polar. H / V
3037.000	36.41	-0.10	36.31	74.00	-37.69	peak	H
4577.000	34.73	4.39	39.12	74.00	-34.88	peak	H
6691.000	33.46	10.01	43.47	74.00	-30.53	peak	H
3023.000	36.91	-0.14	36.77	74.00	-37.23	peak	V
4577.000	34.39	4.39	38.78	74.00	-35.22	peak	V
6663.000	33.87	9.94	43.81	74.00	-30.19	peak	V

Standard:	FCC Part 15C	Test Distance:	3m
Test item:	Radiated Emission	Power:	AC 120V/60Hz
Model Number:	DT10	Temp.(°C)/Hum.(%RH):	26(°C)/60%RH
Mode:	Mode 2	Date:	08/16/2014
Frequency:	2480 MHz	Test By:	Eric Ou Yang

Frequency (MHz)	Reading (dBuV)	Correct Factor (dB/m)	Result (dBuV/m)	Limit (dBuV/m)	Margin (dB)	Remark	Ant.Polar. H / V
3009.000	35.79	-0.17	35.62	74.00	-38.38	peak	H
4626.000	34.01	4.52	38.53	74.00	-35.47	peak	H
6677.000	33.15	9.97	43.12	74.00	-30.88	peak	H
3009.000	37.38	-0.17	37.21	74.00	-36.79	peak	V
4598.000	35.28	4.45	39.73	74.00	-34.27	peak	V
6642.000	33.70	9.87	43.57	74.00	-30.43	peak	V

Standard:	FCC Part 15C	Test Distance:	3m
Test item:	Radiated Emission	Power:	AC 120V/60Hz
Model Number:	DT10	Temp.(°C)/Hum.(%RH):	26(°C)/60%RH
Mode:	Mode 4	Date:	08/16/2014
Frequency:	2402 MHz	Test By:	Eric Ou Yang

Frequency (MHz)	Reading (dBuV)	Correct Factor (dB/m)	Result (dBuV/m)	Limit (dBuV/m)	Margin (dB)	Remark	Ant.Polar. H / V
3023.000	37.53	-0.14	37.39	74.00	-36.61	peak	H
4563.000	33.65	4.36	38.01	74.00	-35.99	peak	H
6726.000	33.16	10.10	43.26	74.00	-30.74	peak	H
2981.000	36.48	-0.25	36.23	74.00	-37.77	peak	V
4633.000	34.48	4.54	39.02	74.00	-34.98	peak	V
6691.000	33.82	10.01	43.83	74.00	-30.17	peak	V

Standard:	FCC Part 15C	Test Distance:	3m
Test item:	Radiated Emission	Power:	AC 120V/60Hz
Model Number:	DT10	Temp.(°C)/Hum.(%RH):	26(°C)/60%RH
Mode:	Mode 4	Date:	08/16/2014
Frequency:	2441 MHz	Test By:	Eric Ou Yang

Frequency (MHz)	Reading (dBuV)	Correct Factor (dB/m)	Result (dBuV/m)	Limit (dBuV/m)	Margin (dB)	Remark	Ant.Polar. H / V
3030.000	36.81	-0.11	36.70	74.00	-37.30	peak	H
4542.000	33.55	4.31	37.86	74.00	-36.14	peak	H
6719.000	33.92	10.09	44.01	74.00	-29.99	peak	H
3023.000	36.58	-0.14	36.44	74.00	-37.56	peak	V
4598.000	34.25	4.45	38.70	74.00	-35.30	peak	V
6691.000	32.87	10.01	42.88	74.00	-31.12	peak	V

Standard:	FCC Part 15C	Test Distance:	3m
Test item:	Radiated Emission	Power:	AC 120V/60Hz
Model Number:	DT10	Temp.(°C)/Hum.(%RH):	26(°C)/60%RH
Mode:	Mode 4	Date:	08/16/2014
Frequency:	2480 MHz	Test By:	Eric Ou Yang

Frequency (MHz)	Reading (dBuV)	Correct Factor (dB/m)	Result (dBuV/m)	Limit (dBuV/m)	Margin (dB)	Remark	Ant.Polar. H / V
3030.000	36.31	-0.11	36.20	74.00	-37.80	peak	H
4598.000	34.11	4.45	38.56	74.00	-35.44	peak	H
6677.000	33.52	9.97	43.49	74.00	-30.51	peak	H
3023.000	36.62	-0.14	36.48	74.00	-37.52	peak	V
4626.000	34.68	4.52	39.20	74.00	-34.80	peak	V
6663.000	33.33	9.94	43.27	74.00	-30.73	peak	V

## 7 20dB RF Bandwidth and 99 % Occupied Bandwidth Measurement

### 7.1. Limit

N/A

### 7.2. Test Setup

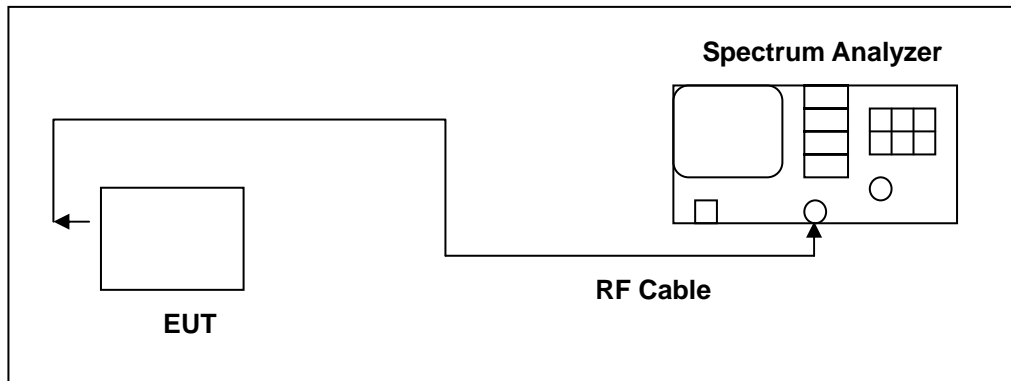

### 7.3. Test Instruments

Equipment	Manufacturer	Model Number	Serial Number	Cal. Date	Remark
Spectrum Analyzer	Agilent	E4445A	MY45300744	12/18/2013	(1)
Test Site	ATL	TE02	TE02	N.C.R.	-----

Remark: (1) Calibration period 1 year. (2) Calibration period 2 years.

NOTE: N.C.R. = No Calibration Request.

### 7.4. Test Procedure

#### 20dB RF Bandwidth

Testing must be done according to this procedure, FCC Public Notice DA 00-705 - Filing and Measurement Guidelines for Frequency Hopping Spread Spectrum Systems. This is the only method recognized by the FCC. The RF output port of the Equipment-Under-Test is directly coupled to the input of the EMC analyzer through a specialized RF connector and a 10dB passive attenuator. A fully charged battery was used for the supply voltage. The Bluetooth frequency hopping function of the EUT was enabled. The spectrum analyzer used the following settings:

1. Span = approx. 2 to 3 times the 20dB bandwidth, centered on a hopping frequency
2. RBW  $\geq$  1% of the 20dB span
3. VBW  $\geq$  RBW
4. Sweep = auto
5. Detector function = peak
6. Trace = max hold

The trace was allowed to stabilize. The EUT was transmitting at its maximum data rate. The marker-to-peak function was used to set the marker to the peak of the emission. The marker-delta function was used to measure 20dB down one side of the emission. The marker-delta function and marker was moved to the other side of the emission until it was even with the reference marker. The marker-delta reading at this point was the 20dB bandwidth of the emission.



#### 99 % Occupied Bandwidth

The transmitter shall be operated at its maximum carrier power measured under normal test conditions.

The span of the analyzer shall be set to capture all products of the modulation process, including the emission skirts.

The resolution bandwidth shall be set to as close to 1% of the selected span as is possible without being below 1%.

The video bandwidth shall be set to 3 times the resolution bandwidth. Video averaging is not permitted. Where practical, a sampling detector shall be used since a peak or, peak hold, may produce a wider bandwidth than actual.

The trace data points are recovered and are directly summed in linear terms. The recovered amplitude data points, beginning at the lowest frequency, are placed in a running sum until 0.5% of the total is reached and that frequency recorded. The process is repeated for the highest frequency data points. This frequency is recorded.

**7.5. Test Result**

Model Number	DT10		
Test Item	20dB RF Bandwidth and 99 % Occupied Bandwidth		
Test Mode	Mode 2: GFSK Link Mode		
Date of Test	08/11/2014	Test Site	TE02
Frequency (MHz)	20dB RF Bandwidth (MHz)	99 % Occupied Bandwidth (MHz)	Limit (MHz)
2402	0.959	0.890	-----
2441	0.948	0.861	-----
2480	0.946	0.855	-----

Model Number	DT10		
Test Item	20dB RF Bandwidth and 99 % Occupied Bandwidth		
Test Mode	Mode 4: 8DPSK Link Mode		
Date of Test	08/11/2014	Test Site	TE02
Frequency (MHz)	20dB RF Bandwidth (MHz)	99 % Occupied Bandwidth (MHz)	Limit (MHz)
2402	1.305	1.177	-----
2441	1.299	1.178	-----
2480	1.300	1.185	-----

**7.6. Test Graphs**

Mode 2: GFSK Link Mode	
2402	
2441	
2480	

Mode 4: 8DPSK Link Mode	
2402	<p>Agilent R T</p> <p>Ch Freq 2.402 GHz Trig Free</p> <p>Occupied Bandwidth</p> <p>Ref 20 dBm #Atten 30 dB</p> <p>#Peak Log 10 dB/Offst 1.8 dB</p> <p>Center 2.402 GHz Span 3 MHz #Res BW 30 kHz #VBW 100 kHz Sweep 5 ms (401 pts)</p> <p><b>Occupied Bandwidth</b> Occ BW % Pwr 99.00 % <b>1.1765 MHz</b> x dB -20.00 dB</p> <p>Transmit Freq Error -19.198 kHz x dB Bandwidth 1.305 MHz</p> <p>Freq/Channel Center Freq 2.40200000 GHz Start Freq 2.40050000 GHz Stop Freq 2.40350000 GHz CF Step 300.000000 kHz Auto Man Freq Offset 0.00000000 Hz Signal Track On Off</p>
2441	<p>Agilent R T</p> <p>Ch Freq 2.441 GHz Trig Free</p> <p>Occupied Bandwidth</p> <p>Ref 20 dBm #Atten 30 dB</p> <p>#Peak Log 10 dB/Offst 1.8 dB</p> <p>Center 2.441 GHz Span 3 MHz #Res BW 30 kHz #VBW 100 kHz Sweep 5 ms (401 pts)</p> <p><b>Occupied Bandwidth</b> Occ BW % Pwr 99.00 % <b>1.1782 MHz</b> x dB -20.00 dB</p> <p>Transmit Freq Error -23.428 kHz x dB Bandwidth 1.299 MHz</p> <p>Freq/Channel Center Freq 2.44100000 GHz Start Freq 2.43950000 GHz Stop Freq 2.44250000 GHz CF Step 300.000000 kHz Auto Man Freq Offset 0.00000000 Hz Signal Track On Off</p>
2480	<p>Agilent R T</p> <p>Ch Freq 2.48 GHz Trig Free</p> <p>Occupied Bandwidth</p> <p>Ref 20 dBm #Atten 30 dB</p> <p>#Peak Log 10 dB/Offst 1.8 dB</p> <p>Center 2.48 GHz Span 3 MHz #Res BW 30 kHz #VBW 100 kHz Sweep 5 ms (401 pts)</p> <p><b>Occupied Bandwidth</b> Occ BW % Pwr 99.00 % <b>1.1847 MHz</b> x dB -20.00 dB</p> <p>Transmit Freq Error -20.776 kHz x dB Bandwidth 1.300 MHz</p> <p>Freq/Channel Center Freq 2.48000000 GHz Start Freq 2.47850000 GHz Stop Freq 2.48150000 GHz CF Step 300.000000 kHz Auto Man Freq Offset 0.00000000 Hz Signal Track On Off</p>

## 8 Carrier Frequency Separation Measurement

### 8.1. Limit

Title 47 of the CFR, Part 15 Subpart (c) 15.247(a)(1) requires the measurement of the bandwidth of the transmission between the -20 dB points on the transmitted spectrum. The results of this test determine the limits for channel spacing. The channel spacing shall be a minimum of 25 kHz or the 20 dB bandwidth, whichever is greater. Alternatively, frequency hopping systems operating in the 2400-2483.5 MHz band may have hopping channel carrier frequencies that are separated by 25 kHz or two-thirds of the 20 dB bandwidth of the hopping channel.

### 8.2. Test Setup

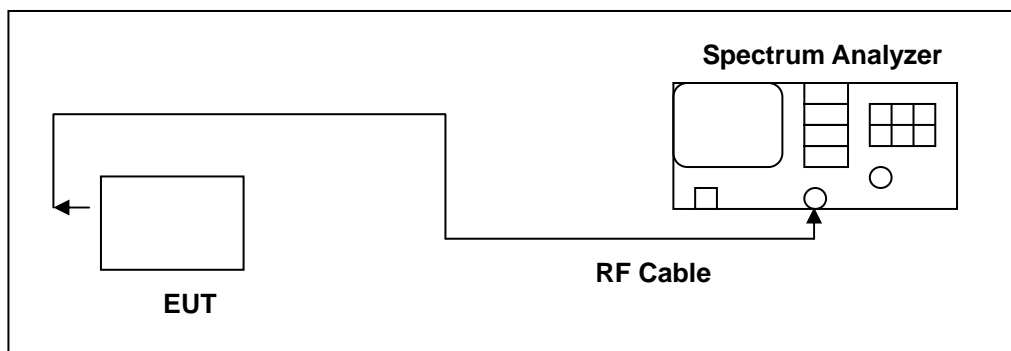

### 8.3. Test Instruments

Equipment	Manufacturer	Model Number	Serial Number	Cal. Date	Remark
Spectrum Analyzer	Agilent	E4445A	MY45300744	12/18/2013	(1)
Test Site	ATL	TE02	TE02	N.C.R.	-----

Remark: (1) Calibration period 1 year. (2) Calibration period 2 years.

NOTE: N.C.R. = No Calibration Request.

### 8.4. Test Procedure

Testing must be done according to this procedure, FCC Public Notice DA 00-705 - Filing and Measurement Guidelines for Frequency Hopping Spread Spectrum Systems. This is the only method recognized by the FCC. The RF output port of the Equipment-Under-Test is directly coupled to the input of the EMC analyzer through a specialized RF connector and a 10dB passive attenuator. A fully charged battery was used for the supply voltage. The Bluetooth transmitter of the V6 had its hopping function enabled. The following spectrum analyzer settings were used:

1. Span = wide enough to capture the peaks of two adjacent channels
2. Resolution (or IF) Bandwidth (RBW)  $\geq$  1% of the span
3. Video (or Average) Bandwidth (VBW)  $\geq$  RBW
4. Sweep = auto
5. Detector function = peak
6. Trace = max hold

The trace was allowed to stabilize. The marker-delta function was used to determine the separation between the peaks of the adjacent channels.

**8.5. Test Result**

Model Number	DT10		
Test Item	Carrier Frequency Separation		
Test Mode	Mode 2: GFSK Link Mode		
Date of Test	08/11/2014	Test Site	TE02
	Frequency (MHz)	Measurement (MHz)	Limit (MHz)
	2402	1	> 0.640
	2441	1	> 0.632
	2480	1	> 0.631

Model Number	DT10		
Test Item	Carrier Frequency Separation		
Test Mode	Mode 4: 8DPSK Link Mode		
Date of Test	08/11/2014	Test Site	TE02
	Frequency (MHz)	Measurement (MHz)	Limit (MHz)
	2402	1	> 0.870
	2441	1	> 0.866
	2480	1	> 0.867

### 8.6. Test Graphs

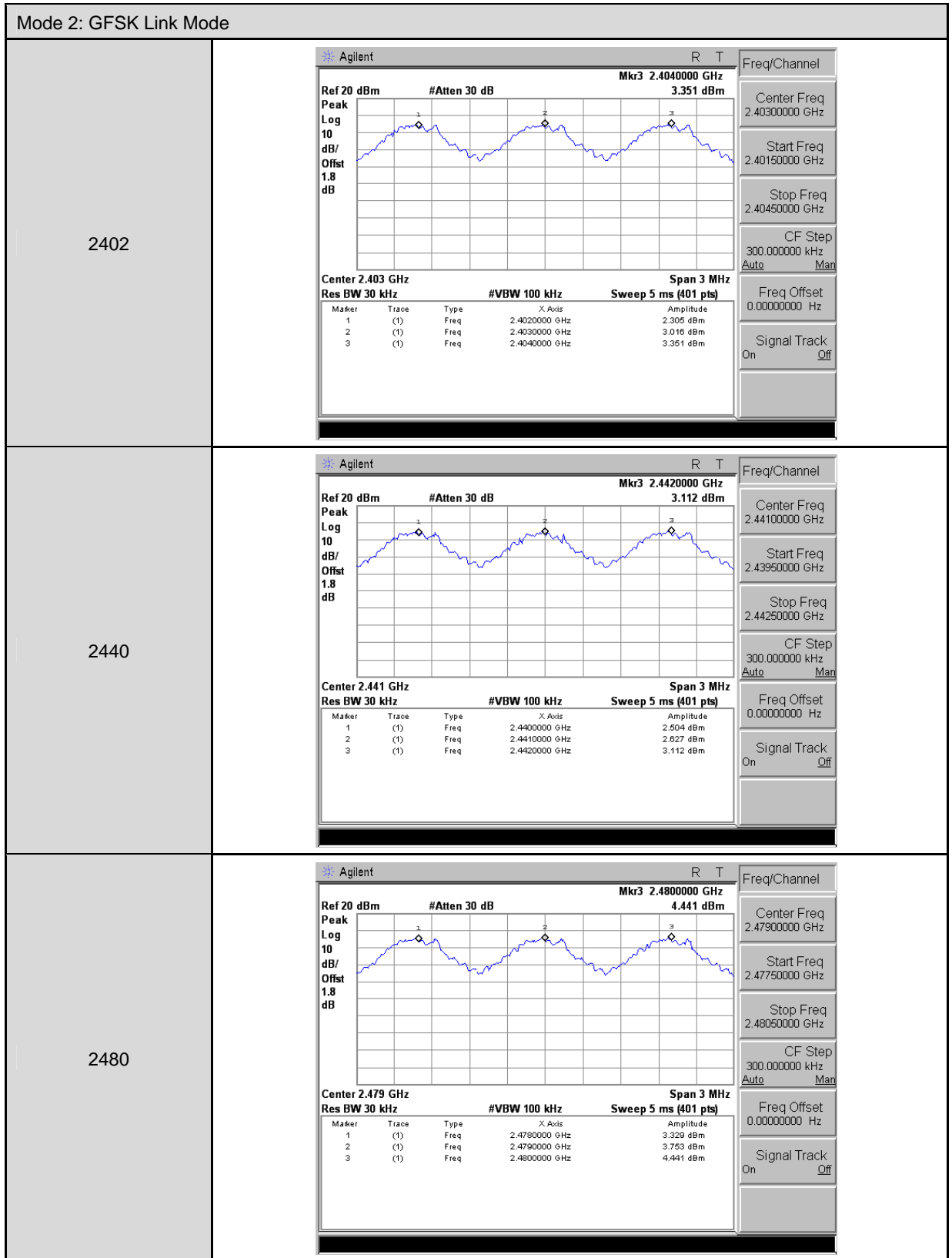

Mode 4: 8DPSK Link Mode																					
2402	<p>Agilent R T</p> <p>Ref 20 dBm #Atten 30 dB Mkr3 2.4040000 GHz -0.37 dBm</p> <p>Peak Log 10 dB/Offst 1.8 dB</p> <p>Center 2.403 GHz Res BW 30 kHz #VBW 100 kHz Span 3 MHz Sweep 5 ms (401 pts)</p> <table border="1"> <thead> <tr> <th>Marker</th> <th>Trace</th> <th>Type</th> <th>X Axis</th> <th>Amplitude</th> </tr> </thead> <tbody> <tr> <td>1</td> <td>(1)</td> <td>Freq</td> <td>2.4020000 GHz</td> <td>-1.748 dBm</td> </tr> <tr> <td>2</td> <td>(1)</td> <td>Freq</td> <td>2.4030000 GHz</td> <td>-0.69 dBm</td> </tr> <tr> <td>3</td> <td>(1)</td> <td>Freq</td> <td>2.4040000 GHz</td> <td>-0.37 dBm</td> </tr> </tbody> </table> <p>Freq/Channel: Center Freq 2.40300000 GHz, Start Freq 2.40150000 GHz, Stop Freq 2.40450000 GHz, CF Step 300.000000 kHz, Freq Offset 0.00000000 Hz, Signal Track On</p>	Marker	Trace	Type	X Axis	Amplitude	1	(1)	Freq	2.4020000 GHz	-1.748 dBm	2	(1)	Freq	2.4030000 GHz	-0.69 dBm	3	(1)	Freq	2.4040000 GHz	-0.37 dBm
Marker	Trace	Type	X Axis	Amplitude																	
1	(1)	Freq	2.4020000 GHz	-1.748 dBm																	
2	(1)	Freq	2.4030000 GHz	-0.69 dBm																	
3	(1)	Freq	2.4040000 GHz	-0.37 dBm																	
2441	<p>Agilent R T</p> <p>Ref 20 dBm #Atten 30 dB Mkr3 2.4420000 GHz 0.339 dBm</p> <p>Peak Log 10 dB/Offst 1.8 dB</p> <p>Center 2.441 GHz Res BW 30 kHz #VBW 100 kHz Span 3 MHz Sweep 5 ms (401 pts)</p> <table border="1"> <thead> <tr> <th>Marker</th> <th>Trace</th> <th>Type</th> <th>X Axis</th> <th>Amplitude</th> </tr> </thead> <tbody> <tr> <td>1</td> <td>(1)</td> <td>Freq</td> <td>2.4400000 GHz</td> <td>-1.049 dBm</td> </tr> <tr> <td>2</td> <td>(1)</td> <td>Freq</td> <td>2.4410000 GHz</td> <td>0.008 dBm</td> </tr> <tr> <td>3</td> <td>(1)</td> <td>Freq</td> <td>2.4420000 GHz</td> <td>0.339 dBm</td> </tr> </tbody> </table> <p>Freq/Channel: Center Freq 2.44100000 GHz, Start Freq 2.43950000 GHz, Stop Freq 2.44250000 GHz, CF Step 300.000000 kHz, Freq Offset 0.00000000 Hz, Signal Track On</p>	Marker	Trace	Type	X Axis	Amplitude	1	(1)	Freq	2.4400000 GHz	-1.049 dBm	2	(1)	Freq	2.4410000 GHz	0.008 dBm	3	(1)	Freq	2.4420000 GHz	0.339 dBm
Marker	Trace	Type	X Axis	Amplitude																	
1	(1)	Freq	2.4400000 GHz	-1.049 dBm																	
2	(1)	Freq	2.4410000 GHz	0.008 dBm																	
3	(1)	Freq	2.4420000 GHz	0.339 dBm																	
2480	<p>Agilent R T</p> <p>Ref 20 dBm #Atten 30 dB Mkr3 2.4800000 GHz 1.851 dBm</p> <p>Peak Log 10 dB/Offst 1.8 dB</p> <p>Center 2.479 GHz Res BW 30 kHz #VBW 100 kHz Span 3 MHz Sweep 5 ms (401 pts)</p> <table border="1"> <thead> <tr> <th>Marker</th> <th>Trace</th> <th>Type</th> <th>X Axis</th> <th>Amplitude</th> </tr> </thead> <tbody> <tr> <td>1</td> <td>(1)</td> <td>Freq</td> <td>2.4780000 GHz</td> <td>-0.231 dBm</td> </tr> <tr> <td>2</td> <td>(1)</td> <td>Freq</td> <td>2.4790000 GHz</td> <td>0.796 dBm</td> </tr> <tr> <td>3</td> <td>(1)</td> <td>Freq</td> <td>2.4800000 GHz</td> <td>1.851 dBm</td> </tr> </tbody> </table> <p>Freq/Channel: Center Freq 2.47900000 GHz, Start Freq 2.47750000 GHz, Stop Freq 2.48050000 GHz, CF Step 300.000000 kHz, Freq Offset 0.00000000 Hz, Signal Track On</p>	Marker	Trace	Type	X Axis	Amplitude	1	(1)	Freq	2.4780000 GHz	-0.231 dBm	2	(1)	Freq	2.4790000 GHz	0.796 dBm	3	(1)	Freq	2.4800000 GHz	1.851 dBm
Marker	Trace	Type	X Axis	Amplitude																	
1	(1)	Freq	2.4780000 GHz	-0.231 dBm																	
2	(1)	Freq	2.4790000 GHz	0.796 dBm																	
3	(1)	Freq	2.4800000 GHz	1.851 dBm																	



## 9 Number of Hopping Measurement

### 9.1. Limit

Frequency hopping systems in the 2400–2483.5 MHz band shall use at least 15 channels.

### 9.2. Test Setup

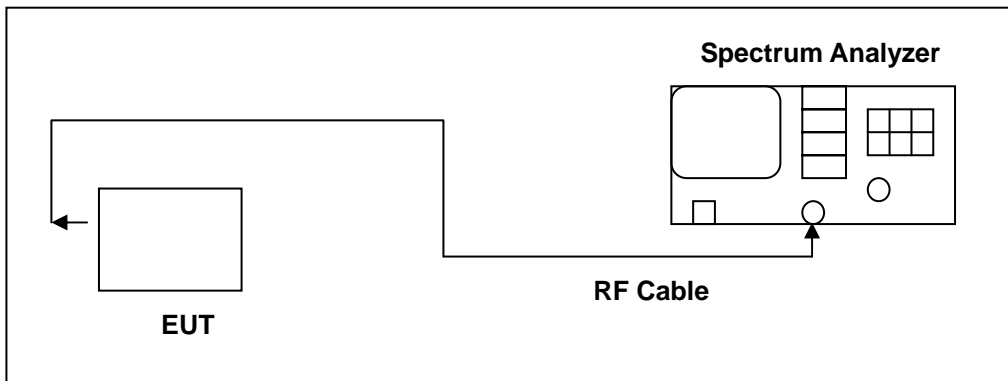

### 9.3. Test Instruments

Equipment	Manufacturer	Model Number	Serial Number	Cal. Date	Remark
Spectrum Analyzer	Agilent	E4445A	MY45300744	12/18/2013	(1)
Test Site	ATL	TE02	TE02	N.C.R.	-----

Remark: (1) Calibration period 1 year. (2) Calibration period 2 years.

NOTE: N.C.R. = No Calibration Request.

### 9.4. Test Procedure

Testing must be done according to this procedure, FCC Public Notice DA 00-705 - Filing and Measurement Guidelines for Frequency Hopping Spread Spectrum Systems. This is the only method recognized by the FCC. The RF output port of the Equipment-Under-Test is directly coupled to the input of the EMC analyzer through a specialized RF connector and a 10dB passive attenuator. A fully charged battery was used for the supply voltage. The Bluetooth frequency hopping function of the EUT was enabled. The spectrum analyzer used the following settings:

1. Span = the frequency band of operation
2. RBW  $\geq$  1% of the span
3. VBW  $\geq$  RBW
4. Sweep = auto
5. Detector function = peak
6. Trace = max hold

The trace was allowed to stabilize.

**9.5. Test Result**

Model Number	DT10		
Test Item	Number of Hopping		
Test Mode	Mode 2: GFSK Link Mode		
Date of Test	08/11/2014	Test Site	TE02
Frequency Range (MHz)	Measurement (ch)		Limit (ch)
2402 - 2480	79		> 15

Model Number	DT10		
Test Item	Number of Hopping		
Test Mode	Mode 4: 8DPSK Link Mode		
Date of Test	08/11/2014	Test Site	TE02
Frequency Range (MHz)	Measurement (ch)		Limit (ch)
2402 - 2480	79		> 15

**9.6. Test Graphs**

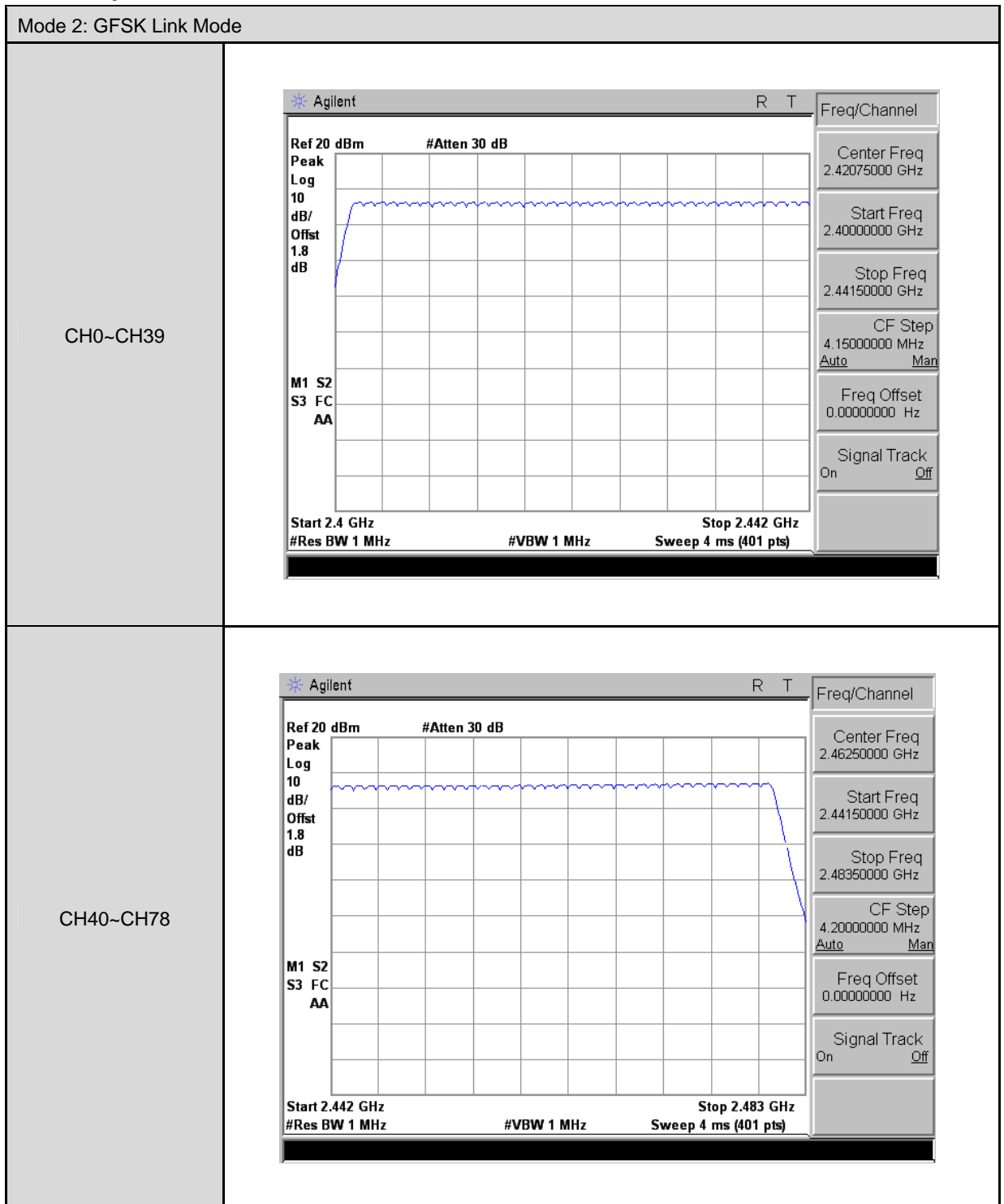

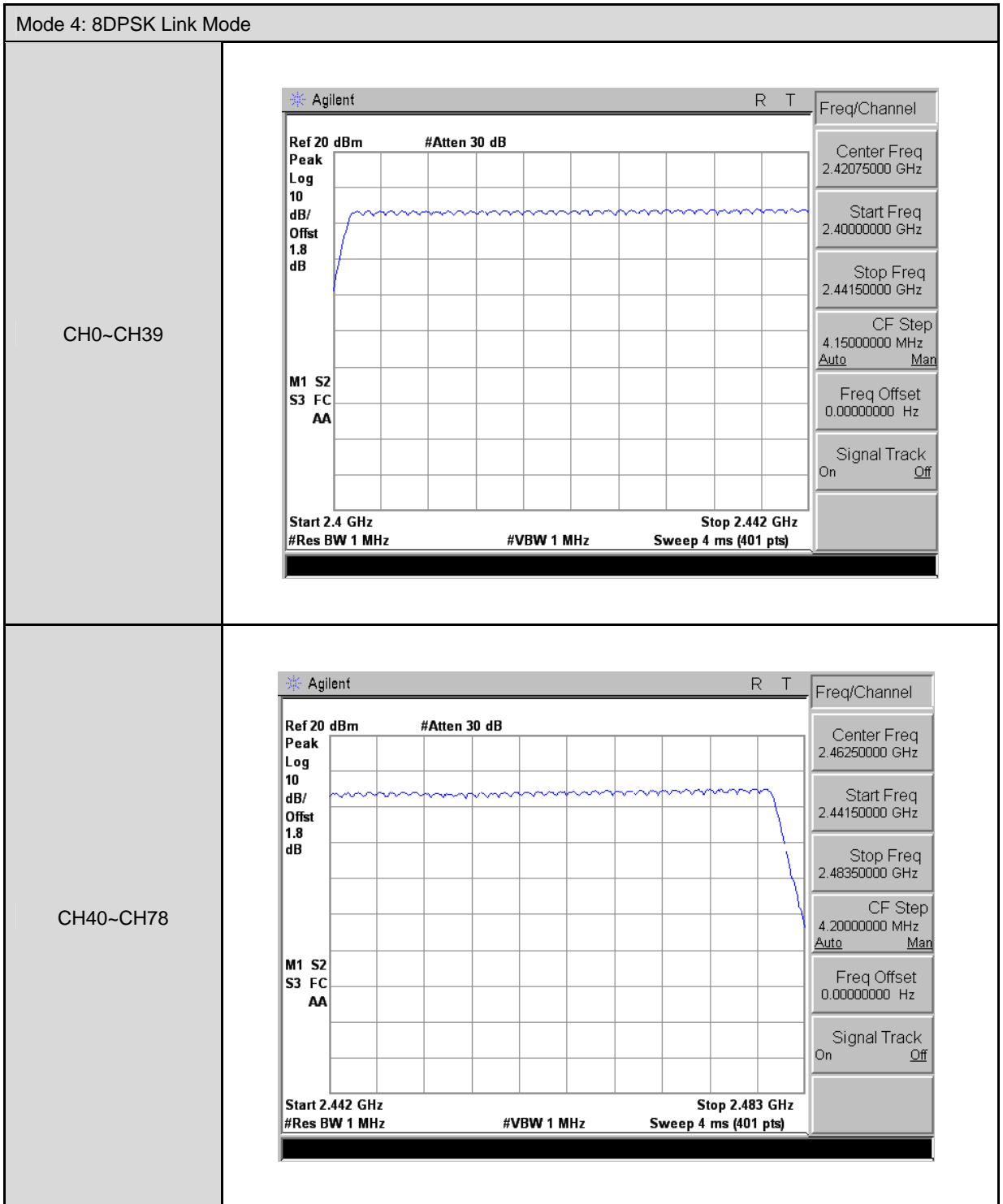

## 10 Time of Occupancy (Dwell Time) Measurement

### 10.1. Limit

The average time of occupancy on any channel shall not be greater than 0.4 seconds within a period of 0.4 seconds multiplied by the number of hopping channels employed.

### 10.2. Test Setup

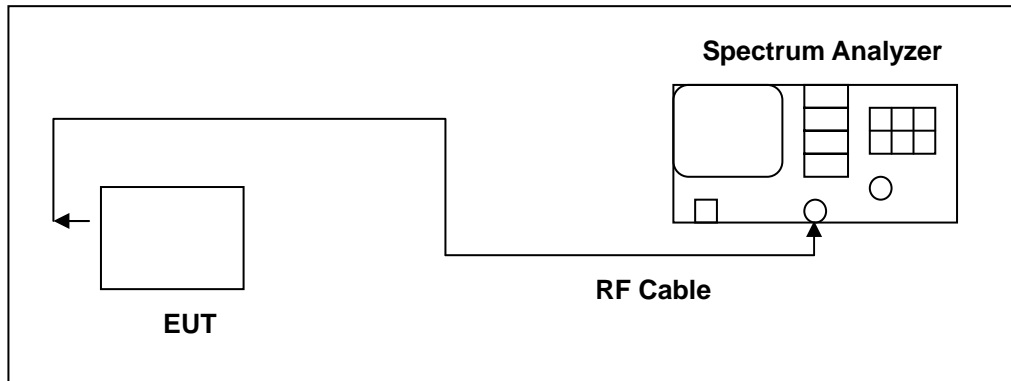

### 10.3. Test Instruments

Equipment	Manufacturer	Model Number	Serial Number	Cal. Date	Remark
Spectrum Analyzer	Agilent	E4445A	MY45300744	12/18/2013	(1)
Test Site	ATL	TE02	TE02	N.C.R.	-----

Remark: (1) Calibration period 1 year. (2) Calibration period 2 years.

NOTE: N.C.R. = No Calibration Request.

### 10.4. Test Procedure

Testing must be done according to this procedure, FCC Public Notice DA 00-705 - Filing and Measurement Guidelines for Frequency Hopping Spread Spectrum Systems. This is the only method recognized by the FCC. The RF output port of the Equipment-Under-Test is directly coupled to the input of the EMC analyzer through a specialized RF connector and a 10dB passive attenuator. A fully charged battery was used for the supply voltage. The Bluetooth hopping function of the EUT was enabled. The following spectrum analyzer settings were used:

1. Span = zero span, centered on a hopping channel
2. RBW = 1 MHz
3. VBW  $\geq$  RBW
4. Sweep = as necessary to capture the entire dwell time per hopping channel
5. Detector function = peak
6. Trace = max hold

The marker-delta function was used to determine the dwell time.

**10.5. Test Result**

Model Number	DT10		
Test Item	Time of Occupancy (Dwell Time)		
Test Mode	Mode 2: GFSK Link Mode		
Date of Test	08/11/2014	Test Site	TE02
DH1			
Cycle Calculate	79CH * 0.4 = 31.6 (sec)		
The EUT Hopping Number per Sec	1600 times/sec		
Each Channel Dwell Times per Sec	800/79CH = 10.13(times/sec)		
Each Channel Dwell Times (1)	0.450	ms (sec)	
Each Channel Dwell Times on Cycle(2)	31.6 * 10.13 = 320.108(times)		
Dwell Times on Cycle (1) * (2)	144.0486	ms (sec)	
LIMIT(msec)	< = 400		
DH3			
Cycle Calculate	79CH * 0.4 = 31.6 (sec)		
The EUT Hopping Number per Sec	1600 times/sec		
Each Channel Dwell Times per Sec	400/79CH = 5.1(times/sec)		
Each Channel Dwell Times (1)	1.700	ms (sec)	
Each Channel Dwell Times on Cycle(2)	31.6 * 5.1 = 161.16(times)		
Dwell Times on Cycle (1) * (2)	273.9720	ms (sec)	
LIMIT(msec)	< = 400		
DH5			
Cycle Calculate	79CH * 0.4 = 31.6 (sec)		
The EUT Hopping Number per Sec	1600 times/sec		
Each Channel Dwell Times per Sec	266.7/79CH = 3.37(times/sec)		
Each Channel Dwell Times (1)	2.975	ms (sec)	
Each Channel Dwell Times on Cycle(2)	31.6 * 3.37 = 106.492(times)		
Dwell Times on Cycle (1) * (2)	316.8137	ms (sec)	
LIMIT(msec)	< = 400		

Model Number	DT10		
Test Item	Time of Occupancy (Dwell Time)		
Test Mode	Mode 4: 8DPSK Link Mode		
Date of Test	08/11/2014	Test Site	TE02
3DH1			
Cycle Calculate	$79CH * 0.4 = 31.6 \text{ (sec)}$		
The EUT Hopping Number per Sec	1600 times/sec		
Each Channel Dwell Times per Sec	$800/79CH = 10.13(\text{times/sec})$		
Each Channel Dwell Times (1)	0.475	ms (sec)	
Each Channel Dwell Times on Cycle(2)	$31.6 * 10.13 = 320.108(\text{times})$		
Dwell Times on Cycle (1) * (2)	152.0513	ms (sec)	
LIMIT(msec)	< = 400		
3DH3			
Cycle Calculate	$79CH * 0.4 = 31.6 \text{ (sec)}$		
The EUT Hopping Number per Sec	1600 times/sec		
Each Channel Dwell Times per Sec	$400/79CH = 5.1(\text{times/sec})$		
Each Channel Dwell Times (1)	1.700	ms (sec)	
Each Channel Dwell Times on Cycle(2)	$31.6 * 5.1 = 161.16(\text{times})$		
Dwell Times on Cycle (1) * (2)	273.9720	ms (sec)	
LIMIT(msec)	< = 400		
3DH5			
Cycle Calculate	$79CH * 0.4 = 31.6 \text{ (sec)}$		
The EUT Hopping Number per Sec	1600 times/sec		
Each Channel Dwell Times per Sec	$266.7/79CH = 3.37(\text{times/sec})$		
Each Channel Dwell Times (1)	2.950	ms (sec)	
Each Channel Dwell Times on Cycle(2)	$31.6 * 3.37 = 106.492(\text{times})$		
Dwell Times on Cycle (1) * (2)	314.1514	ms (sec)	
LIMIT(msec)	< = 400		

**10.6. Test Graphs**

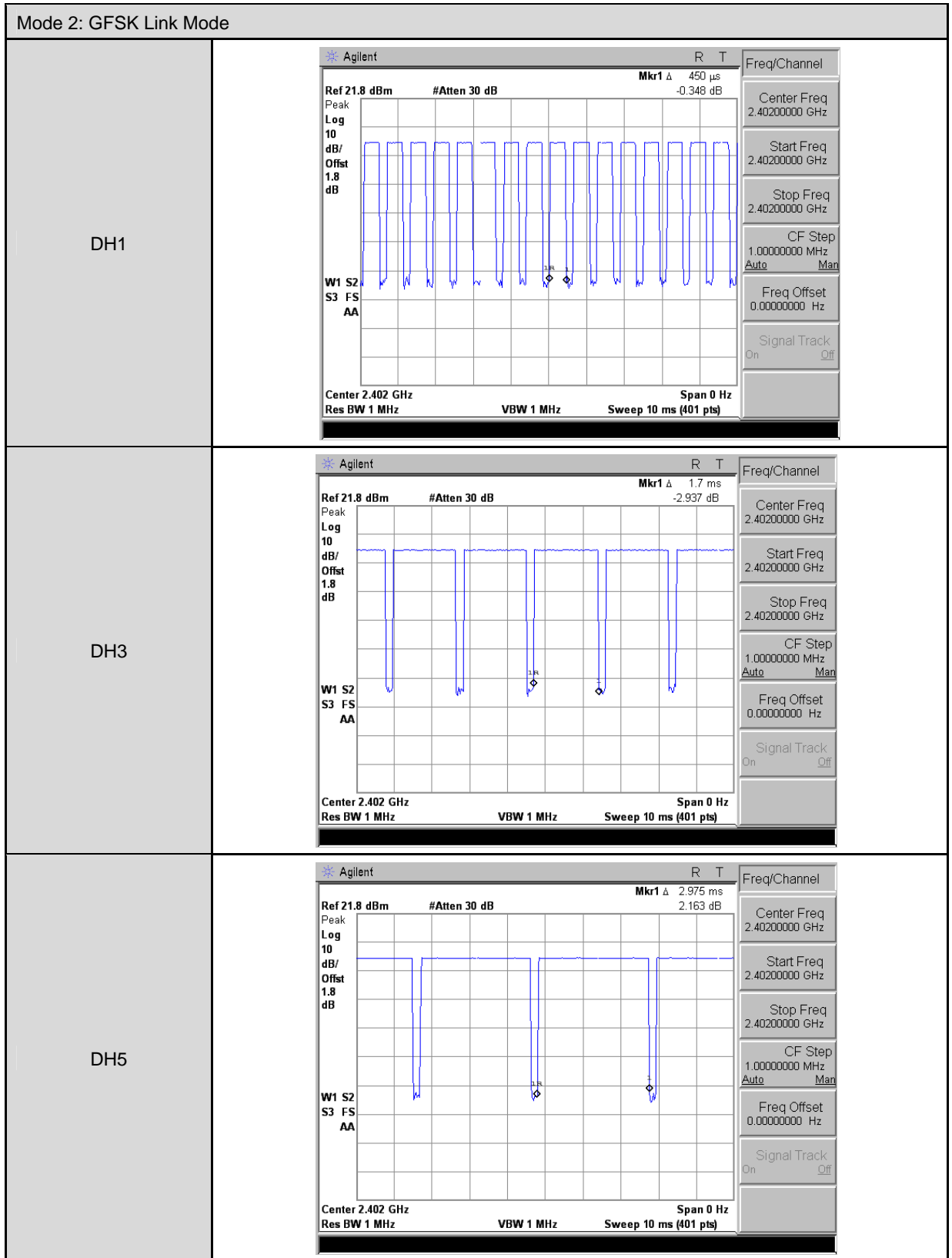



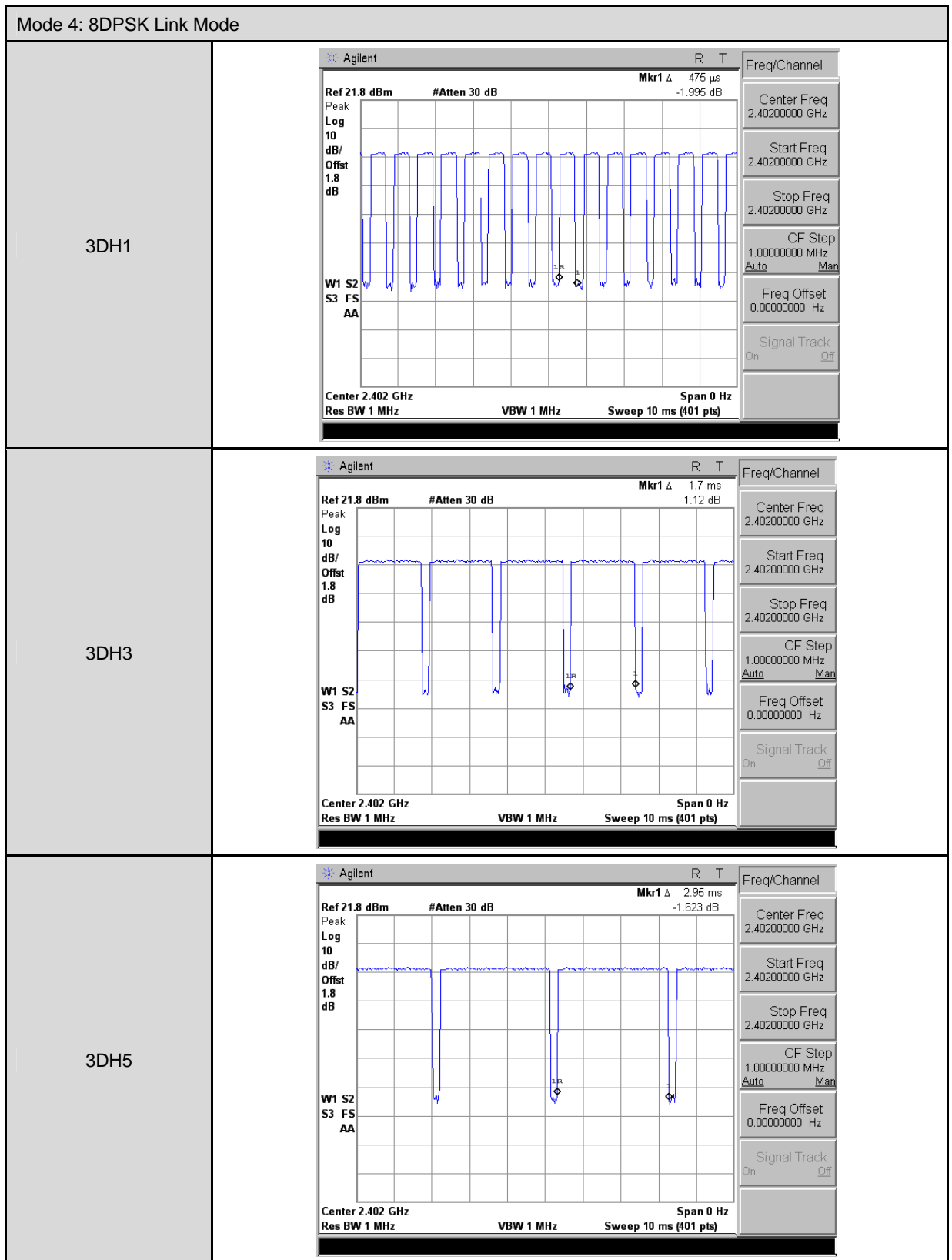

## 11 Out of Band Conducted Emissions Measurement

### 11.1. Limit

In any 100 kHz bandwidth outside the frequency band in which the spread spectrum or digitally modulated intentional radiator is operating, the radio frequency power that is produced by the intentional radiator shall be at least 20 dB below that in the 100 kHz bandwidth within the band that contains the highest level of the desired power

### 11.2. Test Setup

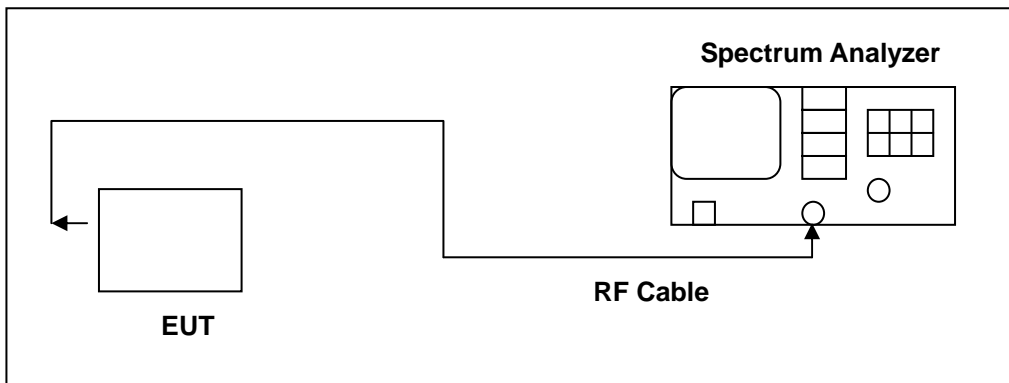

### 11.3. Test Instruments

Equipment	Manufacturer	Model Number	Serial Number	Cal. Date	Remark
Spectrum Analyzer	Agilent	E4445A	MY45300744	12/18/2013	(1)
Spectrum Analyzer	Agilent	E4408B	MY45107753	07/24/2014	(1)
Test Site	ATL	TE02	TE02	N.C.R.	-----

Remark: (1) Calibration period 1 year. (2) Calibration period 2 years.

NOTE: N.C.R. = No Calibration Request.

### 11.4. Test Procedure

Testing must be done according to this procedure, FCC Public Notice DA 00-705 - Filing and Measurement Guidelines for Frequency Hopping Spread Spectrum Systems. This is the only method recognized by the FCC. In any 100 kHz bandwidth outside the EUT pass band, the RF power produced by the modulation products of the spreading sequence, the information sequence, and the carrier frequency shall be at least 20 dB below that of the maximum in-band 100 kHz emission, antenna output of the EUT was coupled directly to spectrum analyzer; if an external attenuator and/or cable was used, these losses are compensated for with the analyzer OFFSET function. All other types of emissions from the EUT shall meet the general limits for radiated frequencies outside the pass band. The test was performed at 3 channels (Channel 0, 39, 78)

**11.5. Test Graphs**

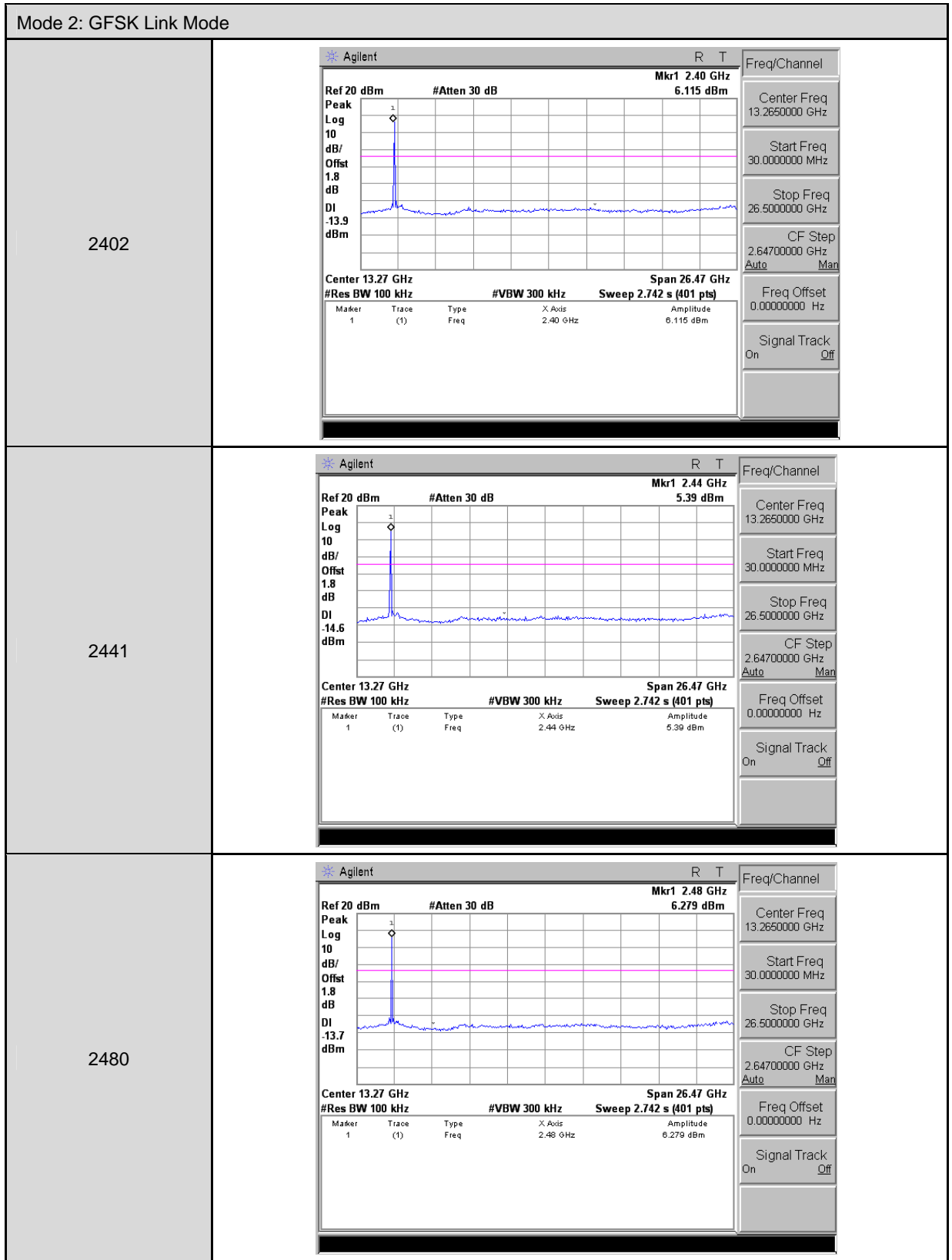

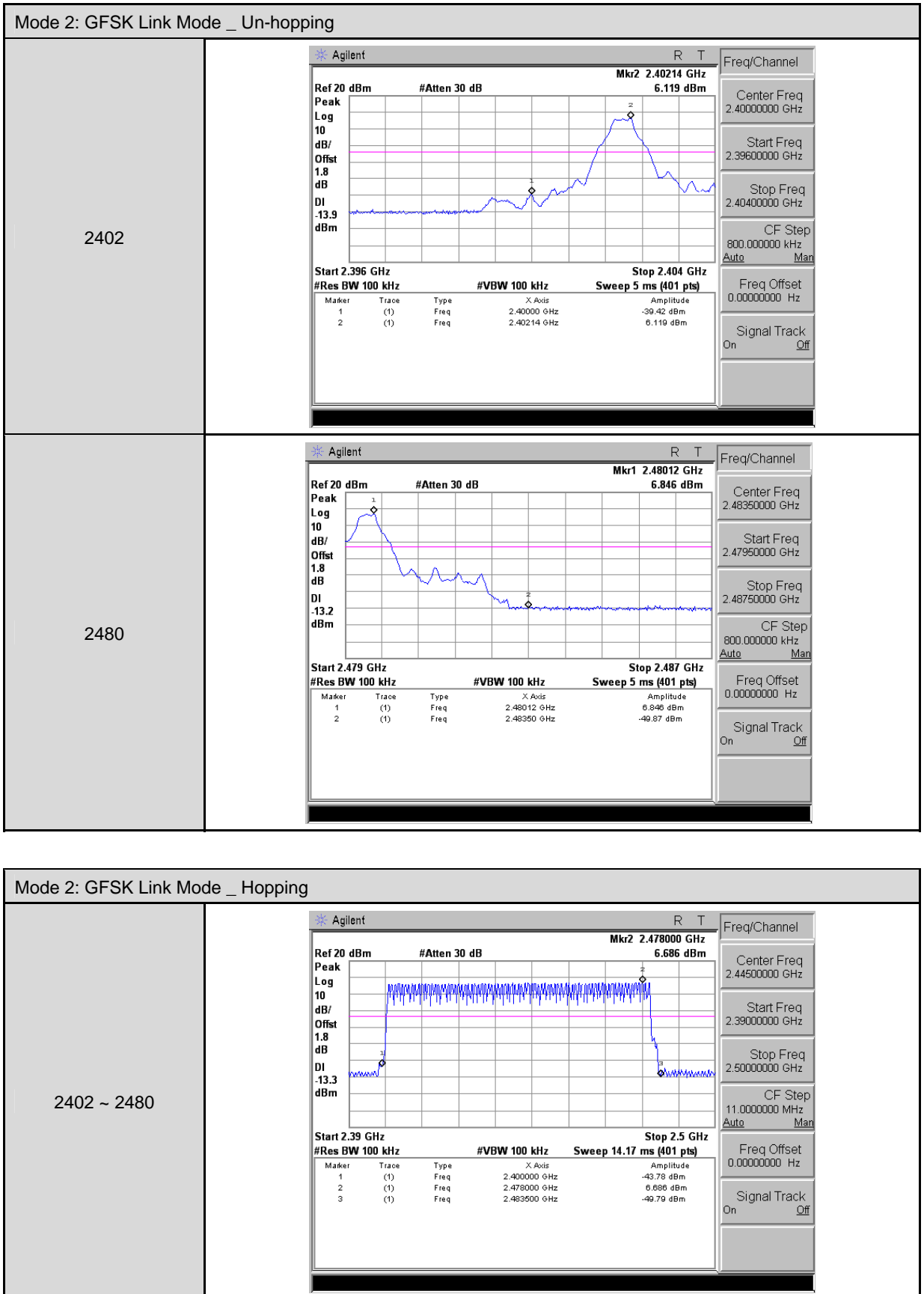

Mode 4: 8DPSK Link Mode	
2402	<p>Agilent R T            Ref 20 dBm #Atten 30 dB Mkr1 2.40 GHz -0.453 dBm            Peak Log 10 dB/Offst 1.8 dB DI -20.5 dBm            Center 13.27 GHz Span 26.47 GHz            #Res BW 100 kHz #VBW 300 kHz Sweep 2.742 s (401 pts)            Marker Trace Type X Axis Amplitude            1 (1) Freq 2.40 GHz -0.453 dBm</p> <p>Freq/Channel            Center Freq 13.2650000 GHz            Start Freq 30.0000000 MHz            Stop Freq 26.5000000 GHz            CF Step 2.64700000 GHz Auto Man            Freq Offset 0.0000000 Hz            Signal Track On Off</p>
2441	<p>Agilent R T            Ref 20 dBm #Atten 30 dB Mkr1 2.44 GHz 0.678 dBm            Peak Log 10 dB/Offst 1.8 dB DI -19.3 dBm            Center 13.27 GHz Span 26.47 GHz            #Res BW 100 kHz #VBW 300 kHz Sweep 2.742 s (401 pts)            Marker Trace Type X Axis Amplitude            1 (1) Freq 2.44 GHz 0.678 dBm</p> <p>Freq/Channel            Center Freq 13.2650000 GHz            Start Freq 30.0000000 MHz            Stop Freq 26.5000000 GHz            CF Step 2.64700000 GHz Auto Man            Freq Offset 0.0000000 Hz            Signal Track On Off</p>
2480	<p>Agilent R T            Ref 20 dBm #Atten 30 dB Mkr1 2.48 GHz 0.581 dBm            Peak Log 10 dB/Offst 1.8 dB DI -19.4 dBm            Center 13.27 GHz Span 26.47 GHz            #Res BW 100 kHz #VBW 300 kHz Sweep 2.742 s (401 pts)            Marker Trace Type X Axis Amplitude            1 (1) Freq 2.48 GHz 0.581 dBm</p> <p>Freq/Channel            Center Freq 13.2650000 GHz            Start Freq 30.0000000 MHz            Stop Freq 26.5000000 GHz            CF Step 2.64700000 GHz Auto Man            Freq Offset 0.0000000 Hz            Signal Track On Off</p>

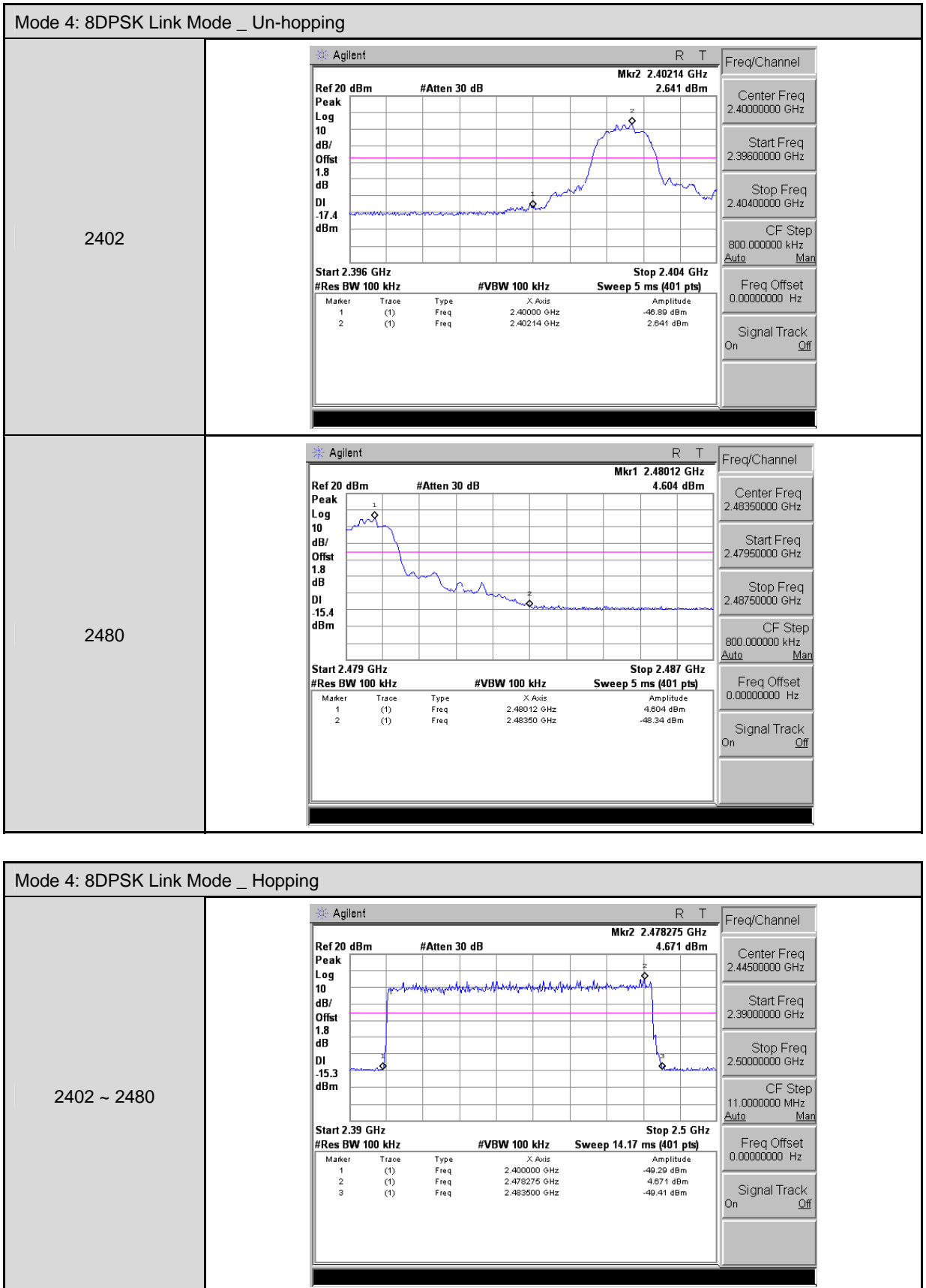

## 12 Band Edges Measurement

### 12.1. Limit

In any 100 kHz bandwidth outside the frequency band in which the spread spectrum or digitally modulated intentional radiator is operating, the radio frequency power that is produced by the intentional radiator shall be at least 20 dB below that in the 100 kHz bandwidth within the band that contains the highest level of the desired power

### 12.2. Test Setup

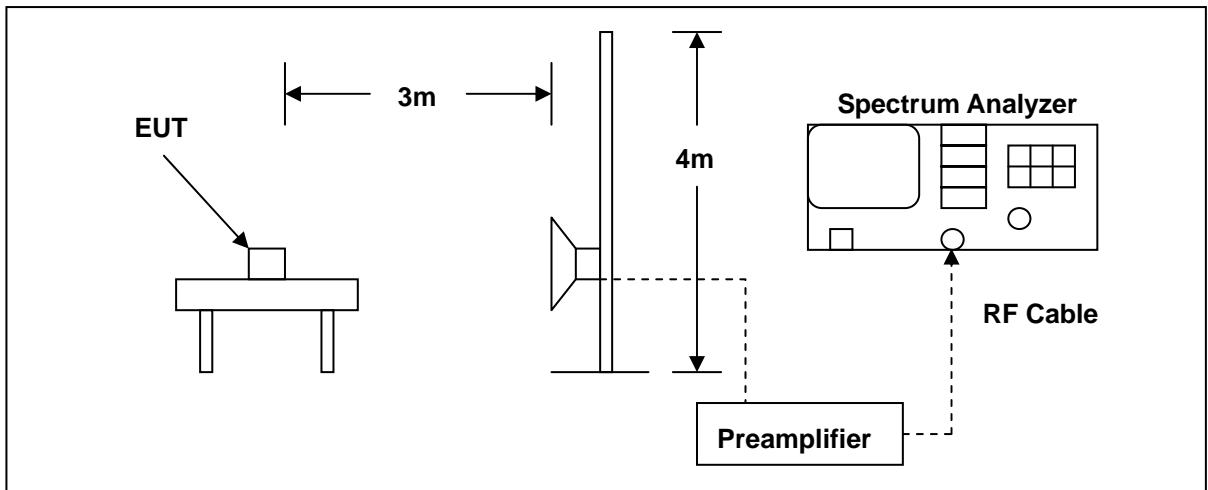

### 12.3. Test Instruments

Equipment	Manufacturer	Model Number	Serial Number	Cal. Date	Remark
Spectrum Analyzer	Agilent	E4408B	MY45107753	07/24/2014	(1)
Pre Amplifier	Agilent	8449B	3008A02237	02/21/2014	(1)
Horn Antenna	SCHWARZBECK MESS-ELEKTRONIK	9120D	9120D-550	06/11/2014	(1)
Test Site	ATL	TE01	888001	08/28/2013	(1)

Remark: (1) Calibration period 1 year. (2) Calibration period 2 years.

NOTE: N.C.R. = No Calibration Request.

## 12.4. Test Procedure

Testing must be done according to this procedure, FCC Public Notice DA 00-705 - Filing and Measurement Guidelines for Frequency Hopping Spread Spectrum Systems. This is the only method recognized by the FCC. The emissions on the harmonics frequencies, the limits, and the margin of compliance are presented. These tests were made when the transmitter was in full radiated power. The additional test was performed to show compliance with the requirement at the band-edge frequency 2483.5 MHz and up to 2500 MHz and at 2390.0 MHz.

The transmitter was configured with the worst case antenna and setup to transmit at the highest channel. Then the field strength was measured at 2483.5 MHz.

The transmitter was then configured with the worst case antenna and setup to transmit at the lowest channel. Then the field strength was measured at 2390.0 MHz. These tests were performed at 4 different bit rates.

For measurements the resolution bandwidth is set to 1 MHz, and then the video bandwidth is set to 1 MHz for peak measurements and 10 Hz for average measurements.



**12.5. Test Result**

Standard:	FCC Part 15C	Test Distance:	3m
Test item:	Radiated Emission	Power:	AC 120V/60Hz
Model Number:	DT10	Temp.(°C)/Hum.(%RH):	26(°C)/60%RH
Mode:	Mode 2	Date:	08/16/2014
Frequency:	2402 MHz	Test By:	Eric Ou Yang

Frequency (MHz)	Reading (dBuV)	Correct Factor (dB/m)	Result (dBuV/m)	Limit (dBuV/m)	Margin (dB)	Remark	Ant.Polar. H / V
2322.100	46.02	-2.25	43.77	74.00	-30.23	peak	H
2390.000	38.13	-1.94	36.19	74.00	-37.81	peak	H
2321.990	43.35	-2.26	41.09	74.00	-32.91	peak	V
2390.000	37.34	-1.94	35.40	74.00	-38.60	peak	V

Standard:	FCC Part 15C	Test Distance:	3m
Test item:	Radiated Emission	Power:	AC 120V/60Hz
Model Number:	DT10	Temp.(°C)/Hum.(%RH):	26(°C)/60%RH
Mode:	Mode 2	Date:	08/16/2014
Frequency:	2480 MHz	Test By:	Eric Ou Yang

Frequency (MHz)	Reading (dBuV)	Correct Factor (dB/m)	Result (dBuV/m)	Limit (dBuV/m)	Margin (dB)	Remark	Ant.Polar. H / V
2483.530	47.68	-1.52	46.16	74.00	-27.84	peak	H
2486.540	43.51	-1.51	42.00	74.00	-32.00	peak	H
2483.500	48.14	-1.52	46.62	74.00	-27.38	peak	V
2492.040	46.97	-1.48	45.49	74.00	-28.51	peak	V

Standard:	FCC Part 15C	Test Distance:	3m
Test item:	Radiated Emission	Power:	AC 120V/60Hz
Model Number:	DT10	Temp.(°C)/Hum.(%RH):	26(°C)/60%RH
Mode:	Mode 4	Date:	08/16/2014
Frequency:	2402 MHz	Test By:	Eric Ou Yang

Frequency (MHz)	Reading (dBuV)	Correct Factor (dB/m)	Result (dBuV/m)	Limit (dBuV/m)	Margin (dB)	Remark	Ant.Polar. H / V
2321.990	43.69	-2.26	41.43	74.00	-32.57	peak	H
2390.000	37.65	-1.94	35.71	74.00	-38.29	peak	H
2322.100	41.12	-2.25	38.87	74.00	-35.13	peak	V
2390.000	38.10	-1.94	36.16	74.00	-37.84	peak	V

Standard:	FCC Part 15C	Test Distance:	3m
Test item:	Radiated Emission	Power:	AC 120V/60Hz
Model Number:	DT10	Temp.(°C)/Hum.(%RH):	26(°C)/60%RH
Mode:	Mode 4	Date:	08/16/2014
Frequency:	2480 MHz	Test By:	Eric Ou Yang

Frequency (MHz)	Reading (dBuV)	Correct Factor (dB/m)	Result (dBuV/m)	Limit (dBuV/m)	Margin (dB)	Remark	Ant.Polar. H / V
2483.500	49.73	-1.52	48.21	74.00	-25.79	peak	H
2483.620	49.26	-1.52	47.74	74.00	-26.26	peak	H
2483.500	49.10	-1.52	47.58	74.00	-26.42	peak	V
2483.600	48.66	-1.52	47.14	74.00	-26.86	peak	V

Standard:	FCC Part 15C	Test Distance:	3m
Test item:	Radiated Emission	Power:	AC 120V/60Hz
Model Number:	DT10	Temp.(°C)/Hum.(%RH):	26(°C)/60%RH
Mode:	Hopping	Date:	08/16/2014
		Test By:	Eric Ou Yang

Frequency (MHz)	Reading (dBuV)	Correct Factor (dB/m)	Result (dBuV/m)	Limit (dBuV/m)	Margin (dB)	Remark	Ant.Polar. H / V
2346.100	51.54	-2.14	49.40	74.00	-24.60	peak	H
2390.000	44.67	-1.94	42.73	74.00	-31.27	peak	H
2483.500	43.42	-1.52	41.90	74.00	-32.10	peak	H
2487.840	44.94	-1.49	43.45	74.00	-30.55	peak	H
2323.680	48.42	-2.25	46.17	74.00	-27.83	peak	V
2390.000	41.80	-1.94	39.86	74.00	-34.14	peak	V
2483.500	42.08	-1.52	40.56	74.00	-33.44	peak	V
2499.050	45.37	-1.44	43.93	74.00	-30.07	peak	V

## **13 Antenna Measurement**

### **13.1. Limit**

For intentional device, according to 15.203, an intentional radiator shall be designed to ensure that no antenna other than that furnished by the responsible party shall be used with the device.

And According to 15.247 (b)(4), if transmitting antennas of directional gain greater than 6 dBi are used, the power shall be reduced by the amount in dB that the directional gain of the antenna exceeds 6dBi.

### **13.2. Antenna Connector Construction**

The antenna used in this product is PIFA Antenna. And the maximum Gain of this antenna is only 1.81 dBi.