



FCC 47 CFR PART 15 SUBPART C

TEST REPORT

For

TABLET COMPUTER

Model: DK886EX

Trade Name: CReTE

Issued to

CReTE SYSTEMS INC

**7F, No. 250, Sec. 3, Pei Shen Rd., Shen Keng Hsiang,
Taipei County, Taiwan.**

Issued by

Compliance Certification Services Inc.

**No. 11, Wu-Gong 6th Rd., Wugu Industrial Park,
Taipei Hsien 248, Taiwan (R.O.C.)**

<http://www.ccsemc.com.tw>

service@ccsrf.com



Testing Laboratory
1309

Note: This report shall not be reproduced except in full, without the written approval of Compliance Certification Services Inc. This document may be altered or revised by Compliance Certification Services Inc. personnel only, and shall be noted in the revision section of the document.



TABLE OF CONTENTS

- 1. TEST RESULT CERTIFICATION.....3**
- 2. EUT DESCRIPTION4**
- 3. TEST METHODOLOGY5**
 - 3.1 EUT CONFIGURATION5
 - 3.2 EUT EXERCISE.....5
 - 3.3 GENERAL TEST PROCEDURES.....5
 - 3.4 FCC PART 15.205 RESTRICTED BANDS OF OPERATIONS6
 - 3.5 DESCRIPTION OF TEST MODES7
- 4. INSTRUMENT CALIBRATION.....8**
 - 4.1 MEASURING INSTRUMENT CALIBRATION8
 - 4.2 MEASUREMENT EQUIPMENT USED8
 - 4.3 MEASUREMENT UNCERTAINTY9
- 5. FACILITIES AND ACCREDITATIONS10**
 - 5.1 FACILITIES10
 - 5.2 EQUIPMENT.....10
 - 5.3 TABLE OF ACCREDITATIONS AND LISTINGS.....11
- 6. SETUP OF EQUIPMENT UNDER TEST12**
 - 6.1 SETUP CONFIGURATION OF EUT.....12
 - 6.2 SUPPORT EQUIPMENT12
- 7. FCC PART 15.247 REQUIREMENTS.....13**
 - 7.1 6DB BANDWIDTH13
 - 7.2 PEAK POWER.....20
 - 7.3 AVERAGE POWER27
 - 7.4 BAND EDGES MEASUREMENT34
 - 7.5 PEAK POWER SPECTRAL DENSITY43
 - 7.6 SPURIOUS EMISSIONS.....50
 - 7.7 POWERLINE CONDUCTED EMISSIONS.....69
- APPENDIX I RADIO FREQUENCY EXPOSURE.....72**
- APPENDIX II PHOTOGRAPHS OF TEST SETUP74**



1. TEST RESULT CERTIFICATION

Applicant: CReTE SYSTEMS INC
 7F, No.250, Sec.3, Pei Shen Rd., Shen Keng Hsiang,,
 Taipei County, Taiwan.

Equipment Under Test: TABLET COMPUTER

Trade Name: CReTE

Model: DK886EX

Date of Test: September 22 ~ October 4, 2009

APPLICABLE STANDARDS	
STANDARD	TEST RESULT
FCC 47 CFR Part 15 Subpart C	No non-compliance noted

We hereby certify that:

The above equipment was tested by Compliance Certification Services Inc. The test data, data evaluation, test procedures, and equipment configurations shown in this report were made in accordance with the procedures given in ANSI C63.4: 2003 and the energy emitted by the sample EUT tested as described in this report is in compliance with the requirements of FCC Rules Part 15.207, 15.209, 15.247.

The test results of this report relate only to the tested sample EUT identified in this report.

Approved by:

Reviewed by:

Rex Lai
 Section Manager
 Compliance Certification Services Inc.

Gina Lo
 Section Manager
 Compliance Certification Services Inc.



2. EUT DESCRIPTION

Product	TABLET COMPUTER
Trade Name	CReTE
Model Number	DK886EX
Model Discrepancy	N/A
Power Supply	1. VDC from Power Adapter FranMar / F10903-A I/P: 100-240VAC, 50-60Hz, 1.2A O/P: 19VDC, 4.75A 2. VDC from Battery Model: BD73B Rating: 11.1V, 7200mAh
Frequency Range	IEEE 802.11a: 5.745~5.825 GHz IEEE 802.11b/g: 2.412~2.462 GHz
Transmit Power	IEEE 802.11a: 19.28 dBm IEEE 802.11b: 19.04 dBm IEEE 802.11g: 22.28 dBm
Modulation Technique	IEEE 802.11a: OFDM (QPSK, BPSK, 16-QAM, 64-QAM) IEEE 802.11b: DSSS (CCK, DQPSK, DBPSK) IEEE 802.11g: DSSS (CCK, DQPSK, DBPSK) + OFDM (QPSK, BPSK, 16-QAM, 64-QAM)
Number of Channels	IEEE 802.11a: 5 Channels IEEE 802.11b/g: 11 Channels
Antenna Specification	IEEE 802.11a: 3.55dBi IEEE 802.11b/g: 1.92dBi
Antenna Designation	IEEE 802.11a/b/g: PIFA Antenna

Remark:

1. The sample selected for test was engineering sample that approximated to production product and was provided by manufacturer.
2. This submittal(s) (test report) is intended for FCC ID: **IR5DK886EX** filing to comply with Section 15.207, 15.209 and 15.247 of the FCC Part 15, Subpart C Rules.



3. TEST METHODOLOGY

The tests documented in this report were performed in accordance with ANSI C63.4 and FCC CFR 47 2.1046, 2.1047, 2.1049, 2.1051, 2.1053, 2.1055, 2.1057, 15.207, 15.209 and 15.247.

3.1 EUT CONFIGURATION

The EUT configuration for testing is installed on RF field strength measurement to meet the Commissions requirement and operating in a manner that intends to maximize its emission characteristics in a continuous normal application.

3.2 EUT EXERCISE

The EUT was operated in the engineering mode to fix the TX frequency that was for the purpose of the measurements.

According to its specifications, the EUT must comply with the requirements of the Section 15.207, 15.209 and 15.247 under the FCC Rules Part 15 Subpart C.

3.3 GENERAL TEST PROCEDURES

Conducted Emissions

The EUT is placed on the turntable, which is 0.8 m above ground plane. According to the requirements in Section 13.1.4.1 of ANSI C63.4: 2003 Conducted emissions from the EUT measured in the frequency range between 0.15 MHz and 30MHz using CISPR Quasi-peak and average detector modes.

Radiated Emissions

The EUT is placed on a turn table, which is 0.8 m above ground plane. The turntable shall rotate 360 degrees to determine the position of maximum emission level. EUT is set 3m away from the receiving antenna, which varied from 1m to 4m to find out the highest emission. And also, each emission was to be maximized by changing the polarization of receiving antenna both horizontal and vertical. In order to find out the maximum emissions, exploratory radiated emission measurements were made according to the requirements in Section 13.1.4.1 of ANSI C63.4: 2003.



3.4 FCC PART 15.205 RESTRICTED BANDS OF OPERATIONS

(a) Except as shown in paragraph (d) of this section, only spurious emissions are permitted in any of the frequency bands listed below:

MHz	MHz	MHz	GHz
0.090 - 0.110	16.42 - 16.423	399.9 - 410	4.5 - 5.15
¹ 0.495 - 0.505	16.69475 - 16.69525	608 - 614	5.35 - 5.46
2.1735 - 2.1905	16.80425 - 16.80475	960 - 1240	7.25 - 7.75
4.125 - 4.128	25.5 - 25.67	1300 - 1427	8.025 - 8.5
4.17725 - 4.17775	37.5 - 38.25	1435 - 1626.5	9.0 - 9.2
4.20725 - 4.20775	73 - 74.6	1645.5 - 1646.5	9.3 - 9.5
6.215 - 6.218	74.8 - 75.2	1660 - 1710	10.6 - 12.7
6.26775 - 6.26825	108 - 121.94	1718.8 - 1722.2	13.25 - 13.4
6.31175 - 6.31225	123 - 138	2200 - 2300	14.47 - 14.5
8.291 - 8.294	149.9 - 150.05	2310 - 2390	15.35 - 16.2
8.362 - 8.366	156.52475 - 156.52525	2483.5 - 2500	17.7 - 21.4
8.37625 - 8.38675	156.7 - 156.9	2655 - 2900	22.01 - 23.12
8.41425 - 8.41475	162.0125 - 167.17	3260 - 3267	23.6 - 24.0
12.29 - 12.293	167.72 - 173.2	3332 - 3339	31.2 - 31.8
12.51975 - 12.52025	240 - 285	3345.8 - 3358	36.43 - 36.5
12.57675 - 12.57725	322 - 335.4	3600 - 4400	(²)
13.36 - 13.41			

¹ Until February 1, 1999, this restricted band shall be 0.490-0.510 MHz.

² Above 38.6

(b) Except as provided in paragraphs (d) and (e), the field strength of emissions appearing within these frequency bands shall not exceed the limits shown in Section 15.209. At frequencies equal to or less than 1000 MHz, compliance with the limits in Section 15.209 shall be demonstrated using measurement instrumentation employing a CISPR quasi-peak detector. Above 1000 MHz, compliance with the emission limits in Section 15.209 shall be demonstrated based on the average value of the measured emissions. The provisions in Section 15.35 apply to these measurements.



3.5 DESCRIPTION OF TEST MODES

The EUT (model: DK886EX) had been tested under operating condition.

Software used to control the EUT for staying in continuous transmitting mode was programmed. The worst case data rate is determined as the data rate with highest output power.

After verification, all tests were carried out with the worst case test modes as shown below except radiated spurious emission below 1GHz and power line conducted emissions below 30MHz, which worst case was in normal link mode only.

IEEE 802.11a mode:

Channel Low(5745MHz), Channel Mid(5785MHz) and Channel High(5825MHz) with 6Mbps data rate were chosen for full testing.

IEEE 802.11b mode:

Channel Low(2412MHz), Channel Mid(2437MHz) and Channel High(2462MHz) with 1Mbps data rate were chosen for full testing.

IEEE 802.11g mode:

Channel Low(2412MHz), Channel Mid(2437MHz) and Channel High(2462MHz) with 6Mbps data rate were chosen for full testing.



4. INSTRUMENT CALIBRATION

4.1 MEASURING INSTRUMENT CALIBRATION

The measuring equipment, which was utilized in performing the tests documented herein, has been calibrated in accordance with the manufacturer's recommendations for utilizing calibration equipment, which is traceable to recognized national standards.

4.2 MEASUREMENT EQUIPMENT USED

Equipment Used for Emissions Measurement

Remark: Each piece of equipment is scheduled for calibration once a year.

Conducted Emissions Test Site				
Name of Equipment	Manufacturer	Model	Serial Number	Calibration Due
Spectrum Analyzer	Agilent	E4446A	MY43360131	02/23/2010

3M Semi Anechoic Chamber				
Name of Equipment	Manufacturer	Model	Serial Number	Calibration Due
Spectrum Analyzer	Agilent	E4446A	US42510252	09/09/2010
Test Receiver	Rohde&Schwarz	ESCI	100064	11/30/2009
Switch Controller	TRC	Switch Controller	SC94050010	05/02/2010
4 Port Switch	TRC	4 Port Switch	SC94050020	05/02/2010
Loop Antenna	EMCO	6502	8905/2356	05/29/2010
Horn-Antenna	TRC	HA-0502	06	06/03/2010
Horn-Antenna	TRC	HA-0801	04	06/17/2010
Horn-Antenna	TRC	HA-1201A	01	08/09/2010
Horn-Antenna	TRC	HA-1301A	01	08/10/2010
Bilog- Antenna	Sunol Sciences	JB3	A030205	03/28/2010
Turn Table	Max-Full	MFT-120S	T120S940302	N.C.R.
Antenna Tower	Max-Full	MFA-430	A440940302	N.C.R.
Controller	Max-Full	MF-CM886	CC-C-1F-13	N.C.R.
Site NSA	CCS	N/A	FCC MRA: TW1039 IC: 2324G-1 / -2	10/17/2010 11/04/2010
Test S/W	LABVIEW (V 6.1)			

Powerline Conducted Emissions Test Site				
Name of Equipment	Manufacturer	Model	Serial Number	Calibration Due
EMI Test Receiver 9kHz-30MHz	Rohde & Schwarz	ESHS30	828144/003	11/19/2009
TWO-Line V-Network 9kHz-30MHz	Schaffner	NNB41	03/10013	06/10/2010
LISN 10kHz-100MHz	EMCO	3825/2	9106-1809	04/08/2010
Test S/W	LABVIEW (V 6.1)			



4.3 MEASUREMENT UNCERTAINTY

PARAMETER	UNCERTAINTY
Powerline Conducted Emission	+/- 2.81
3M Semi Anechoic Chamber / 30MHz ~ 1GHz	+/-3.7046
3M Semi Anechoic Chamber / Above 1GHz	+/-3.0958

Remark: This uncertainty represents an expanded uncertainty expressed at approximately the 95% confidence level using a coverage factor of $k=2$.



5. FACILITIES AND ACCREDITATIONS

5.1 FACILITIES

All measurement facilities used to collect the measurement data are located at

No.199, Chunghsen Road, Hsintien City, Taipei Hsien, Taiwan, R.O.C.

Tel: 886-2-2217-0894 / Fax: 886-2-2217-1029

No.11, Wugong 6th Rd., Wugu Industrial Park, Taipei Hsien 248, Taiwan

Tel: 886-2-2299-9720 / Fax: 886-2-2298-4045

No.81-1, Lane 210, Bade 2nd Rd., Luchu Hsiang, Taoyuan Hsien 338, Taiwan

Tel: 886-3-324-0332 / Fax: 886-3-324-5235

The sites are constructed in conformance with the requirements of ANSI C63.7, ANSI C63.4 and CISPR Publication 22.

5.2 EQUIPMENT

Radiated emissions are measured with one or more of the following types of linearly polarized antennas: tuned dipole, biconical, log periodic, bi-log, and/or ridged waveguide, horn. Spectrum analyzers with pre-selectors and quasi-peak detectors are used to perform radiated measurements.



Conducted emissions are measured with Line Impedance Stabilization Networks and EMI Test Receivers.

Calibrated wideband preamplifiers, coaxial cables, and coaxial attenuators are also used for making measurements.

All receiving equipment conforms to CISPR Publication 16-1, "Radio Interference Measuring Apparatus and Measurement Methods."



5.3 TABLE OF ACCREDITATIONS AND LISTINGS

Country	Agency	Scope of Accreditation	Logo
USA	FCC	3M Semi Anechoic Chamber (FCC MRA: TW1039) to perform FCC Part 15 measurements	 FCC MRA: TW1039
Taiwan	TAF	LP0002, RTTE01, FCC Method-47 CFR Part 15 Subpart C, D, E, RSS-210, RSS-310 IDA TS SRD, AS/NZS 4268, AS/NZS 4771, TS 12.1 & 12.2, ETSI EN 300 440-1, ETSI EN 300 440-2, ETSI EN 300 328, ETSI EN 300 220-1, ETSI EN 300 220-2, ETSI EN 301 893, ETSI EN 301 489-1/3/7/17 FCC OET Bulletin 65 + Supplement C, EN 50360, EN 50361, EN 50371, RSS 102, EN 50383, EN 50385, EN 50392, IEC 62209, CNS 14958-1, CNS 14959 FCC Method -47 CFR Part 15 Subpart B IEC / EN 61000-3-2, IEC / EN 61000-3-3, IEC / EN 61000-4-2/3/4/5/6/8/11	 Testing Laboratory 1309
Canada	Industry Canada	3M Semi Anechoic Chamber (IC 2324G-1 / IC 2324G-2) to perform	 IC 2324G-1 IC 2324G-2

* No part of this report may be used to claim or imply product endorsement by A2LA or any agency of the US Government.



6. SETUP OF EQUIPMENT UNDER TEST

6.1 SETUP CONFIGURATION OF EUT

See test photographs attached in Appendix II for the actual connections between EUT and support equipment.

6.2 SUPPORT EQUIPMENT

No.	Device Type	Brand	Model	Series No.	FCC ID	Data Cable	Power Cord
1.	USB Keyboard	DELL	Sk-8115	N/A	FCC DoC	Shielded, 1.8m	N/A
2.	USB Mouse	Logitech	M-UAG96B	HC8500L	FCC DoC	Shielded, 1.8m	N/A
3.	Modem	ACEEX	DM-1414	304012269	IFAXDM1414	Shielded, 1.8m	Unshielded, 1.8m
4.	SD Card	SANDISK	N/A	AA0312MX	N/A	N/A	N/A
5.	PCI-E Card	N/A	N/A	N/A	N/A	N/A	N/A
6.	Notebook PC (Remote)	DELL	PP05L	7T390 A03	E2K5HCKT	LAN Cable: Unshielded, 10m	AC I/P: Unshielded, 1.8m DC O/P: Unshielded, 1.8m with a core
7.	Super a/g 108Mbps Wireless Lan Router (Remote)	PLANEX	BLW-04SAG	40DDA0421	SJ9-BLW54SAG	N/A	Unshielded, 1.8m

Remark:

1. All the equipment/cables were placed in the worst-case configuration to maximize the emission during the test.
2. Grounding was established in accordance with the manufacturer's requirements and conditions for the intended use.



7. FCC PART 15.247 REQUIREMENTS

7.1 6dB BANDWIDTH

LIMIT

According to §15.247(a)(2), systems using digital modulation techniques may operate in the 902 - 928 MHz, 2400 - 2483.5 MHz, and 5725 - 5850 MHz bands. The minimum 6dB bandwidth shall be at least 500 kHz.

Test Configuration

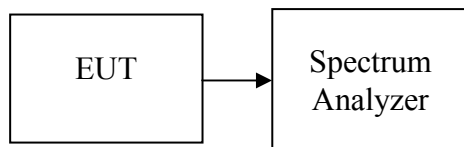

TEST PROCEDURE

1. Place the EUT on the table and set it in the transmitting mode.
2. Remove the antenna from the EUT and then connect a low loss RF cable from the antenna port to the spectrum analyzer.
3. Set the spectrum analyzer as RBW = 100kHz, VBW = RBW, Span = 50MHz, Sweep = auto.
4. Mark the peak frequency and -6dB (upper and lower) frequency.
5. Repeat until all the rest channels are investigated.

TEST RESULTS

No non-compliance noted



Test Data

IEEE 802.11b

Channel	Frequency (MHz)	Bandwidth (kHz)	Limit (kHz)	Test Result
Low	2412	7580	>500	PASS
Mid	2437	8170		PASS
High	2462	7920		PASS

IEEE 802.11g

Channel	Frequency (MHz)	Bandwidth (kHz)	Limit (kHz)	Test Result
Low	2412	16500	>500	PASS
Mid	2437	16500		PASS
High	2462	16500		PASS

IEEE 802.11a

Channel	Frequency (MHz)	Bandwidth (kHz)	Limit (kHz)	Test Result
Low	5745	16500	>500	PASS
Mid	5785	16580		PASS
High	5825	16580		PASS



Test Plot

IEEE 802.11b mode

CH Low

Agilent 10:58:59 Sep 29, 2009

R T

Δ Mkr1 7.58 MHz
-0.35 dB

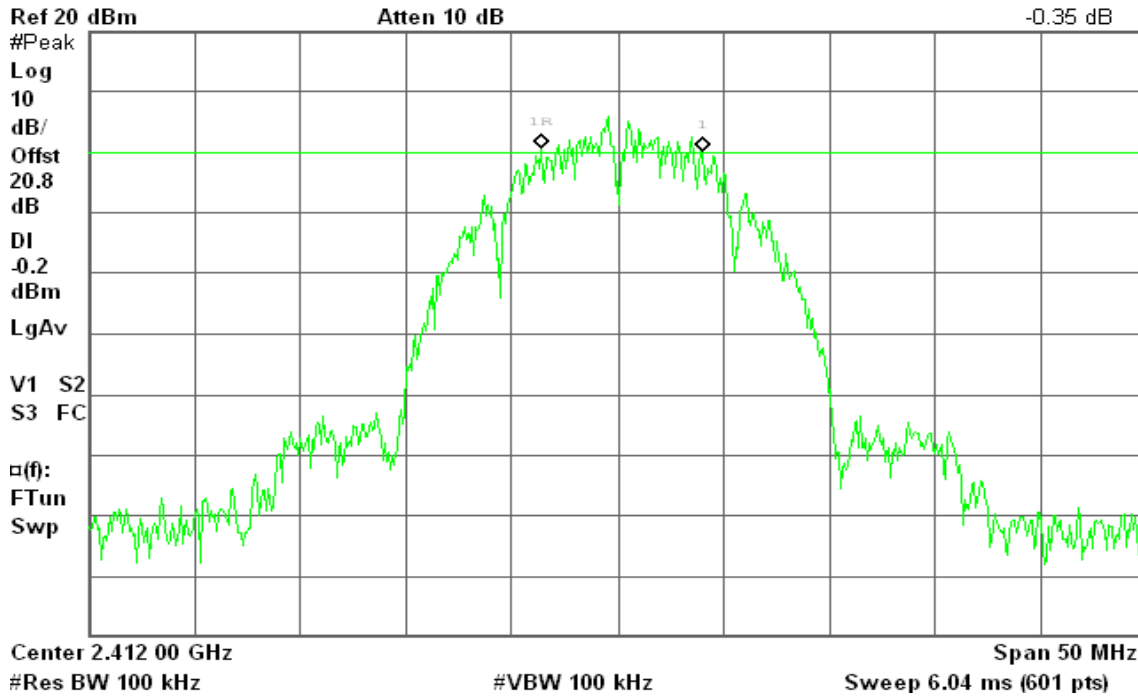

CH Mid

Agilent 11:04:20 Sep 29, 2009

R T

Δ Mkr1 8.17 MHz
-0.18 dB

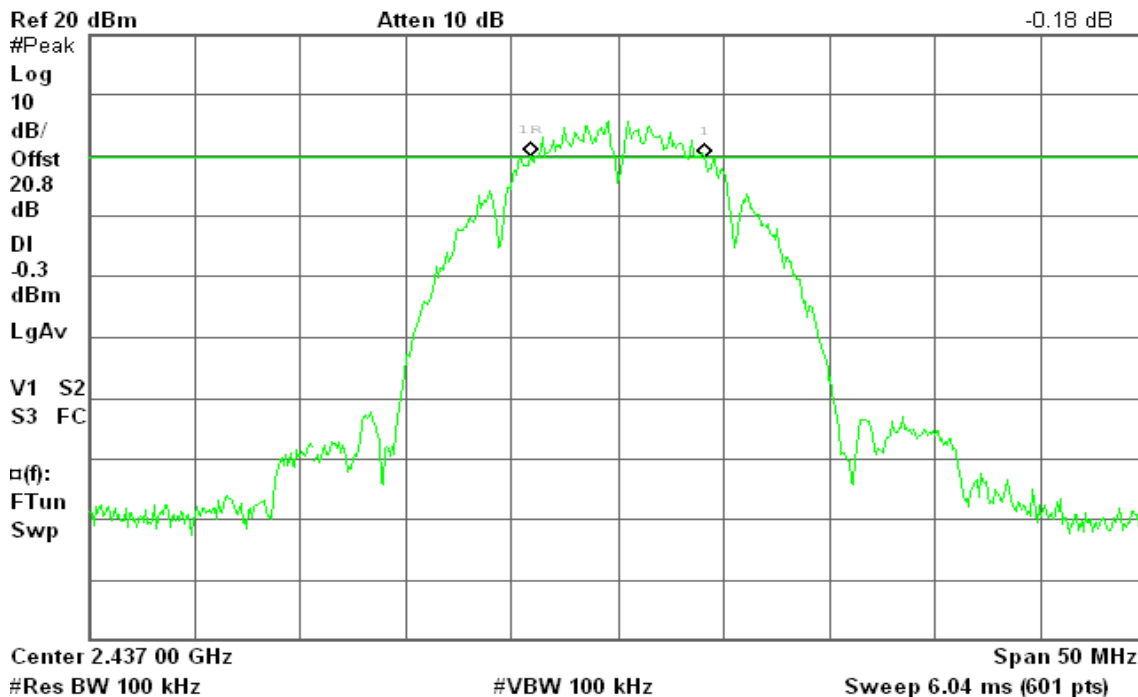



CH High

Agilent 11:09:55 Sep 29, 2009

R T

Δ Mkr1 7.92 MHz
-0.81 dB

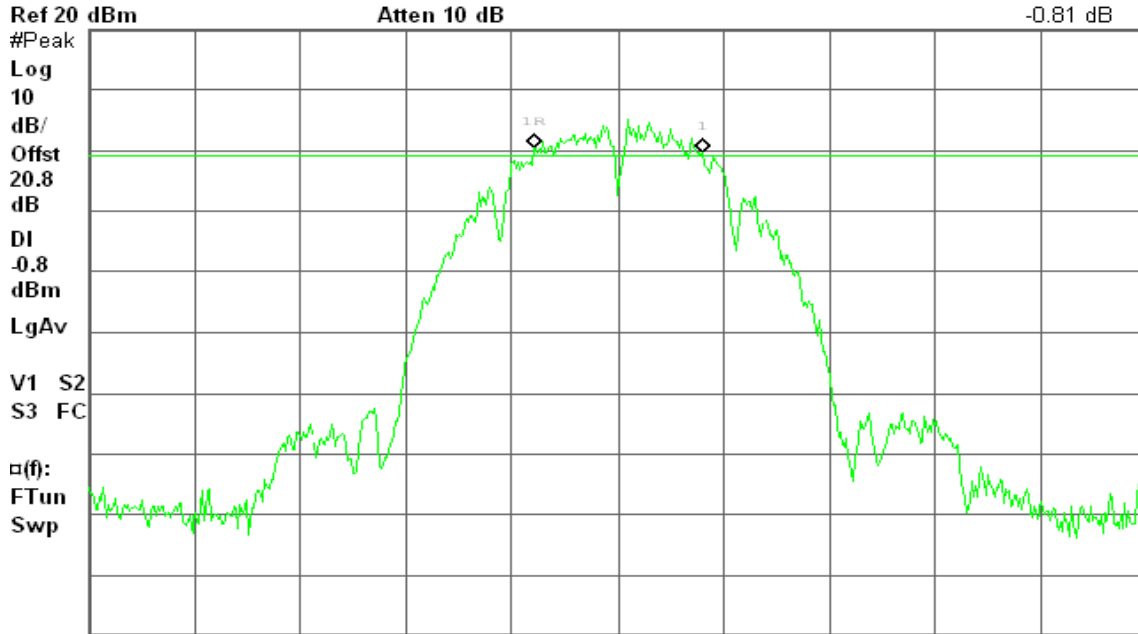

Center 2.462 00 GHz Span 50 MHz
#Res BW 100 kHz #VBW 100 kHz Sweep 6.04 ms (601 pts)

IEEE 802.11g mode

CH Low

Agilent 11:19:35 Sep 29, 2009

R T

Δ Mkr1 16.50 MHz
0.35 dB

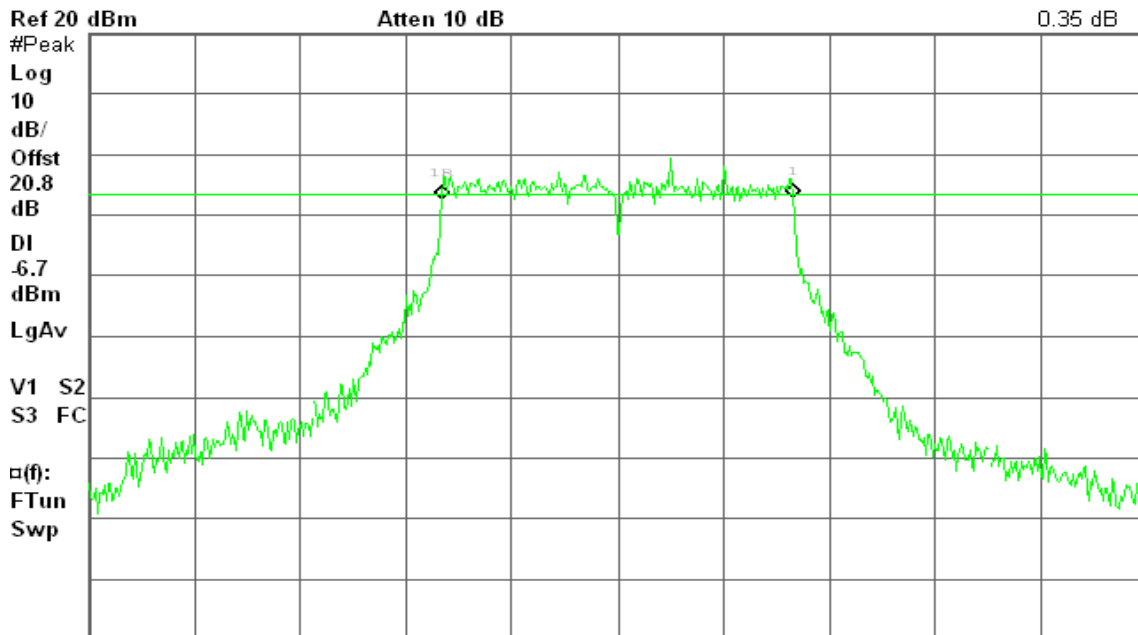

Center 2.412 00 GHz Span 50 MHz
#Res BW 100 kHz #VBW 100 kHz Sweep 6.04 ms (601 pts)



CH Mid

Agilent 11:25:04 Sep 29, 2009

R T

Δ Mkr1 16.50 MHz
-0.43 dB

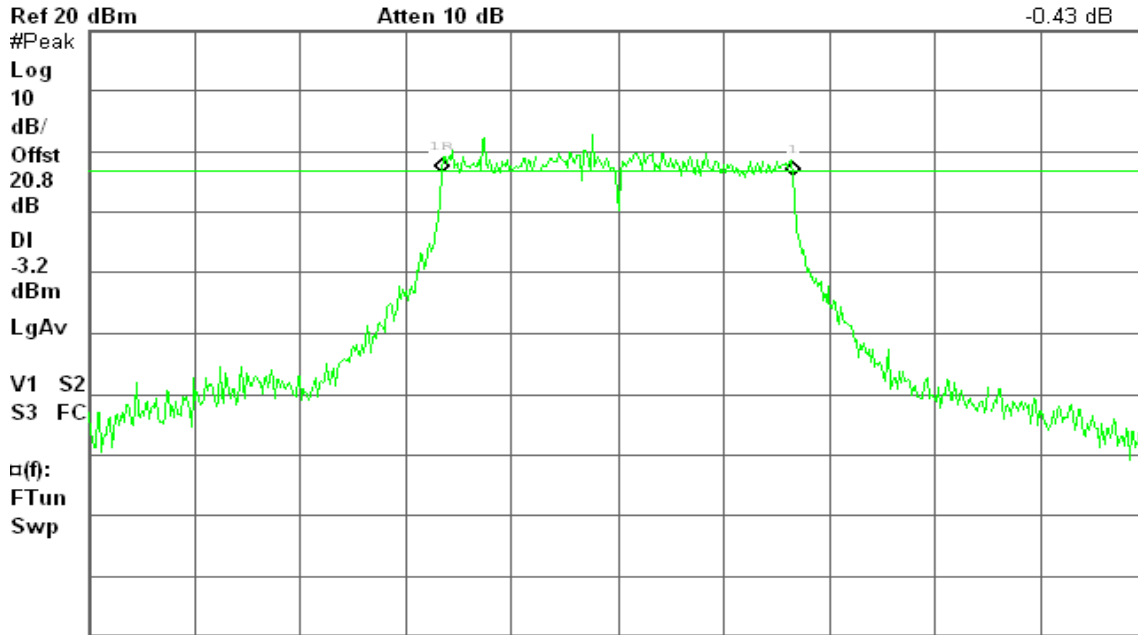

Center 2.437 00 GHz

Span 50 MHz

#Res BW 100 kHz

#VBW 100 kHz

Sweep 6.04 ms (601 pts)

CH High

Agilent 11:30:03 Sep 29, 2009

R T

Δ Mkr1 16.50 MHz
-1.35 dB

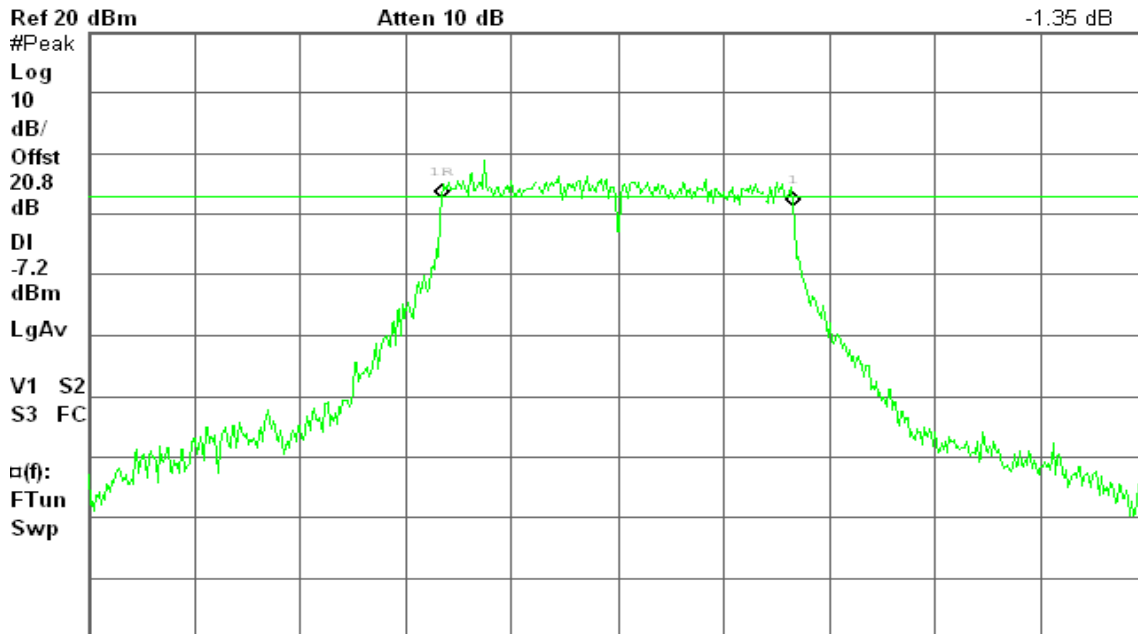

Center 2.462 00 GHz

Span 50 MHz

#Res BW 100 kHz

#VBW 100 kHz

Sweep 6.04 ms (601 pts)



IEEE 802.11a mode

CH Low

Agilent 11:54:51 Sep 29, 2009

R T

Δ Mkr1 16.50 MHz

-1.31 dB

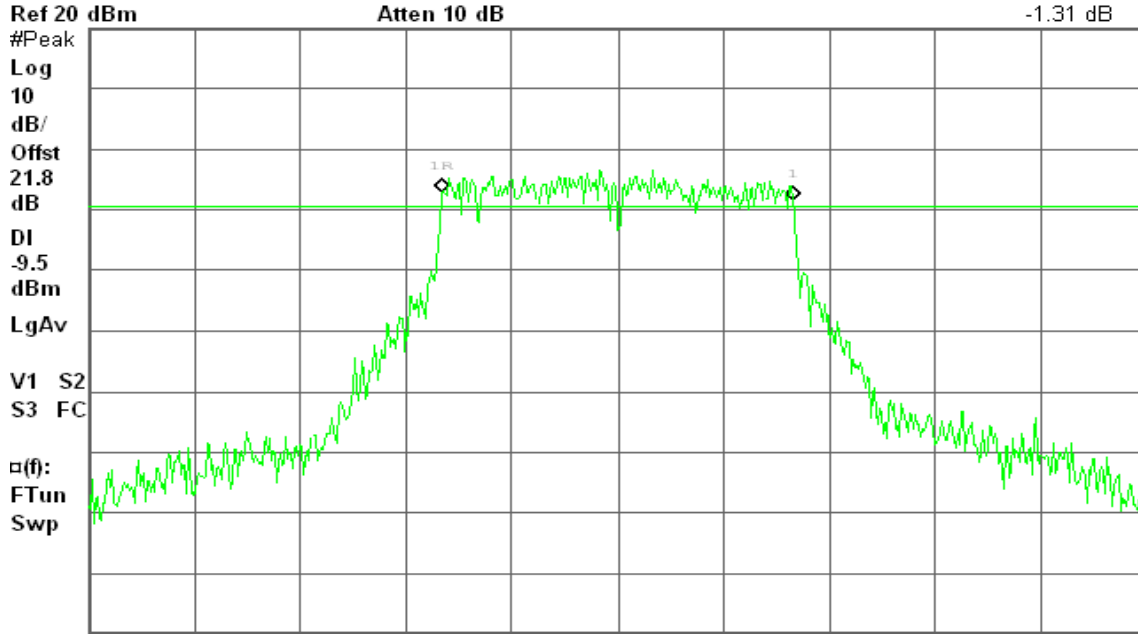

Center 5.745 00 GHz

Span 50 MHz

#Res BW 100 kHz

#VBW 100 kHz

Sweep 6.04 ms (601 pts)

CH Mid

Agilent 13:08:07 Sep 29, 2009

R T

Δ Mkr1 16.58 MHz

-3.29 dB

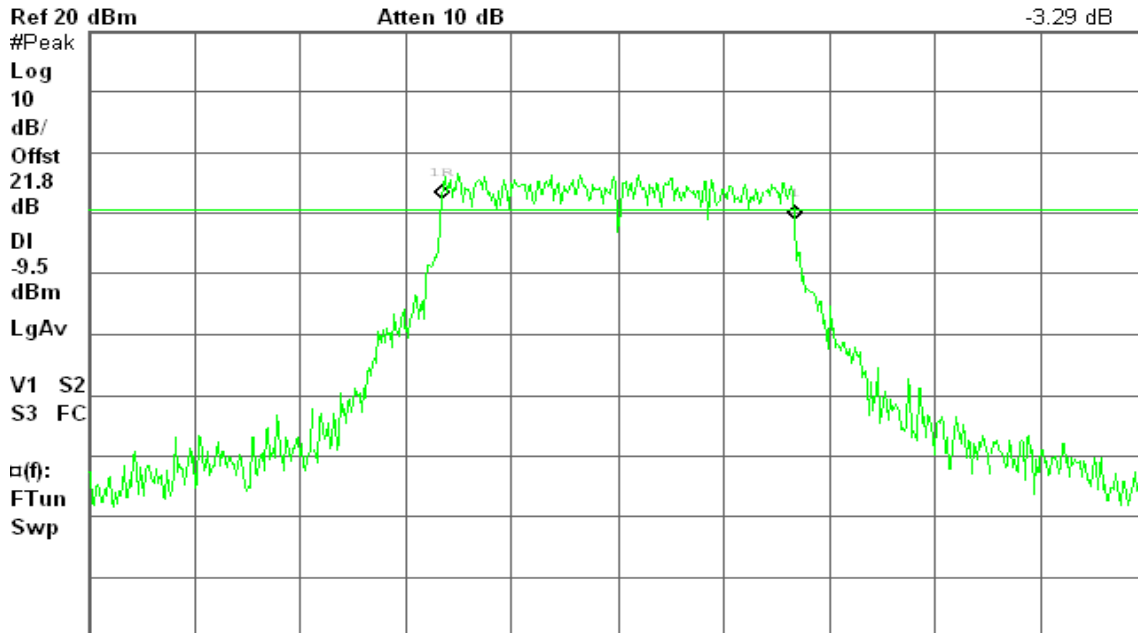

Center 5.785 00 GHz

Span 50 MHz

#Res BW 100 kHz

#VBW 100 kHz

Sweep 6.04 ms (601 pts)



CH High

Agilent 13:13:19 Sep 29, 2009

R T

Δ Mkr1 16.58 MHz

0.11 dB

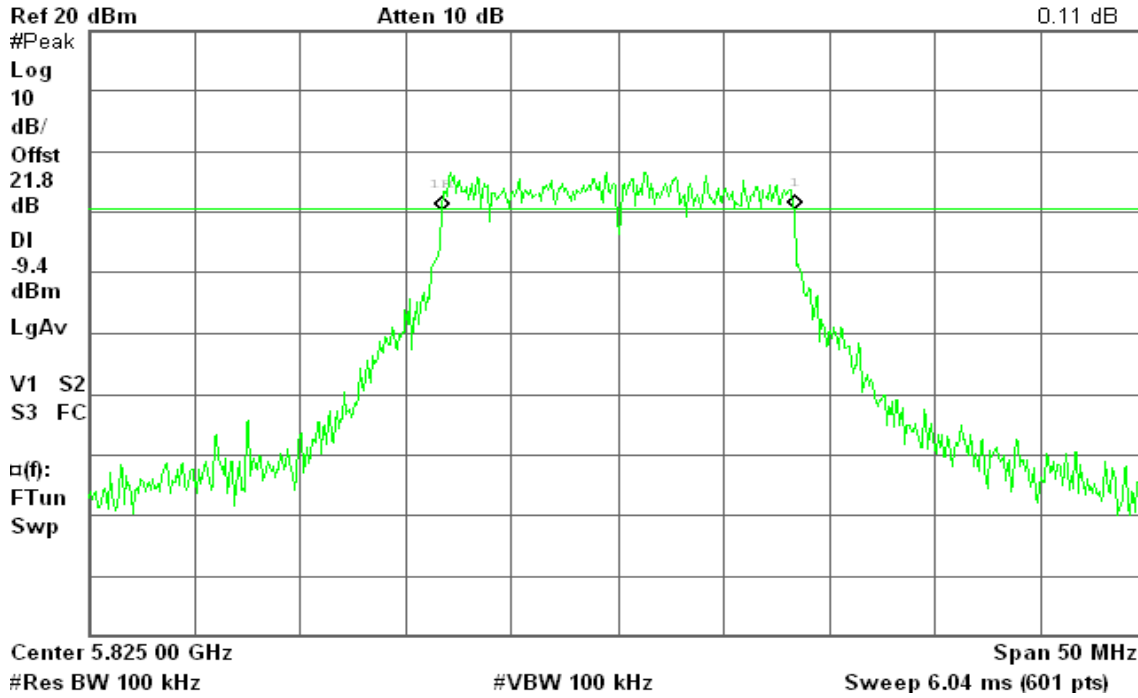



7.2 PEAK POWER

LIMIT

The maximum peak output power of the intentional radiator shall not exceed the following:

1. According to §15.247(b)(3), for systems using digital modulation in the bands of 902-928 MHz, 2400-2483.5 MHz, and 5725-5850 MHz: 1 Watt.
2. According to §15.247(b)(4), the conducted output power limit specified in paragraph (b) of this section is based on the use of antennas with directional gains that do not exceed 6 dBi. Except as shown in paragraph (c) of this section, if transmitting antennas of directional gain greater than 6 dBi are used, the conducted output power from the intentional radiator shall be reduced below the stated values in paragraphs (b)(1), (b)(2), and (b)(3) of this section, as appropriate, by the amount in dB that the directional gain of the antenna exceeds 6 dBi.

Test Configuration

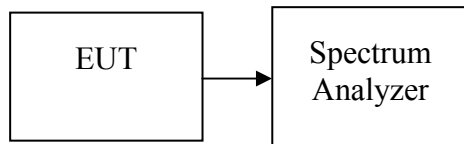

TEST PROCEDURE

1. Peak power is measured using the spectrum analyzer's internal channel power integration function.
2. Power is integrated over a bandwidth greater than or equal to the 99% bandwidth.

TEST RESULTS

No non-compliance noted.



Test Data

IEEE 802.11b

Channel	Frequency (MHz)	Output Power (dBm)	Output Power (W)	Limit (W)	Test Result
Low	2412	18.37	0.0687	1	PASS
Mid	2437	19.04	0.0802		PASS
High	2462	18.33	0.0681		PASS

IEEE 802.11g

Channel	Frequency (MHz)	Output Power (dBm)	Output Power (W)	Limit (W)	Test Result
Low	2412	19.00	0.0794	1	PASS
Mid	2437	22.28	0.1690		PASS
High	2462	18.57	0.0719		PASS

IEEE 802.11a

Channel	Frequency (MHz)	Output Power (dBm)	Output Power (W)	Limit (W)	Test Result
Low	5745	19.28	0.0847	1	PASS
Mid	5785	18.66	0.0735		PASS
High	5825	18.88	0.0773		PASS



Test Plot

IEEE 802.11b mode

CH Low

Agilent 10:22:05 Sep 29, 2009

R T

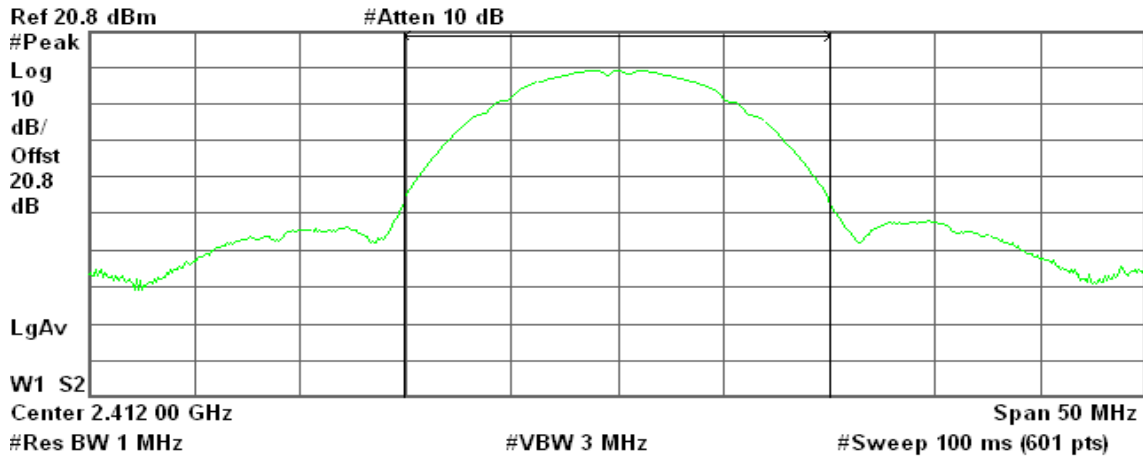

Channel Power

18.37 dBm / 20.0000 MHz

Power Spectral Density

-54.64 dBm/Hz

CH Mid

Agilent 10:26:36 Sep 29, 2009

R T

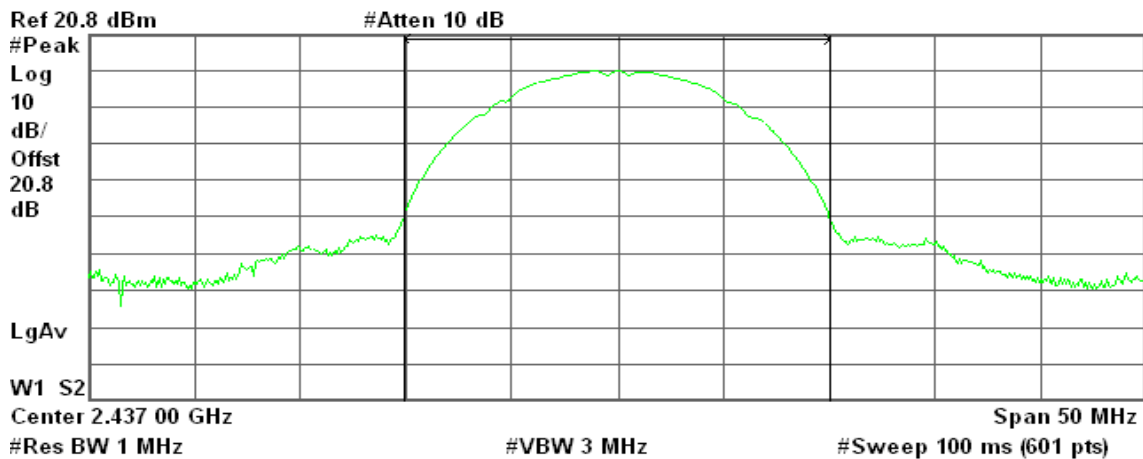

Channel Power

19.04 dBm / 20.0000 MHz

Power Spectral Density

-53.97 dBm/Hz



CH High

Agilent 10:28:17 Sep 29, 2009

R T

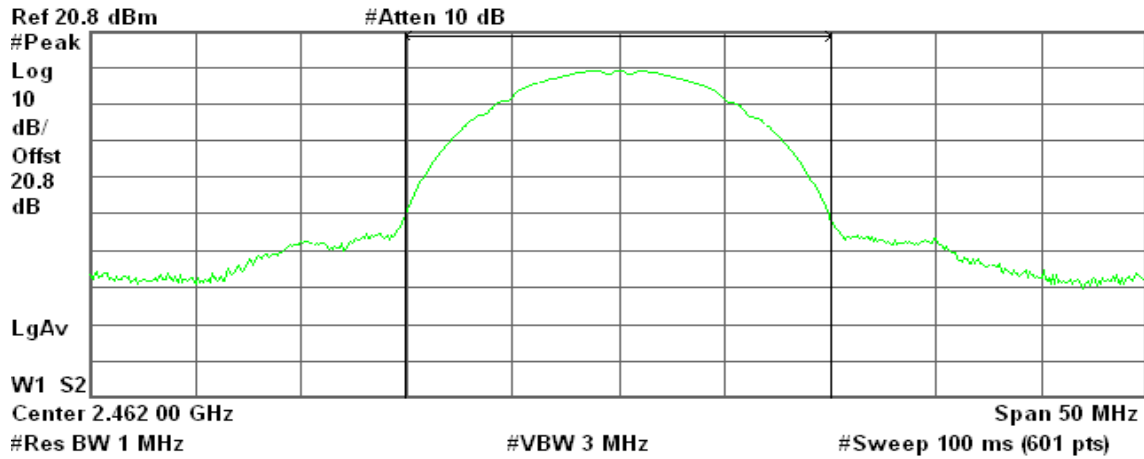

Channel Power

18.33 dBm / 20.0000 MHz

Power Spectral Density

-54.68 dBm/Hz

IEEE 802.11g mode

CH Low

Agilent 10:40:50 Sep 29, 2009

R T

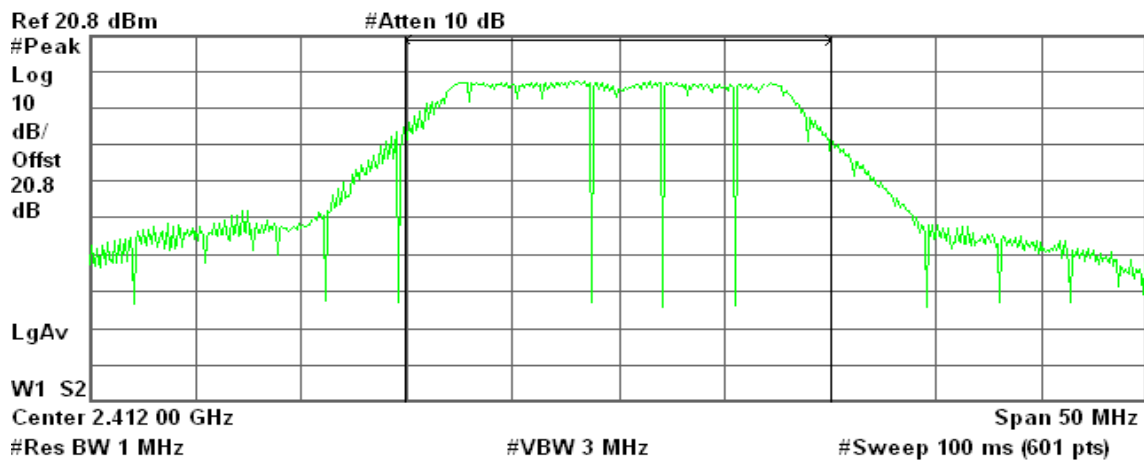

Channel Power

19.00 dBm / 20.0000 MHz

Power Spectral Density

-54.02 dBm/Hz



CH Mid

Agilent 10:53:43 Sep 29, 2009

R T

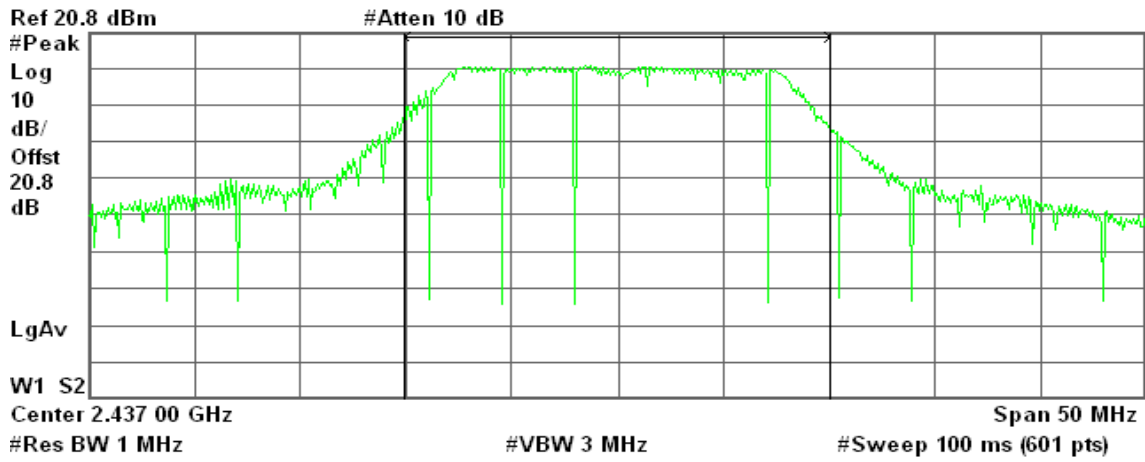

Channel Power

22.28 dBm / 20.0000 MHz

Power Spectral Density

-50.73 dBm/Hz

CH High

Agilent 10:55:37 Sep 29, 2009

R T

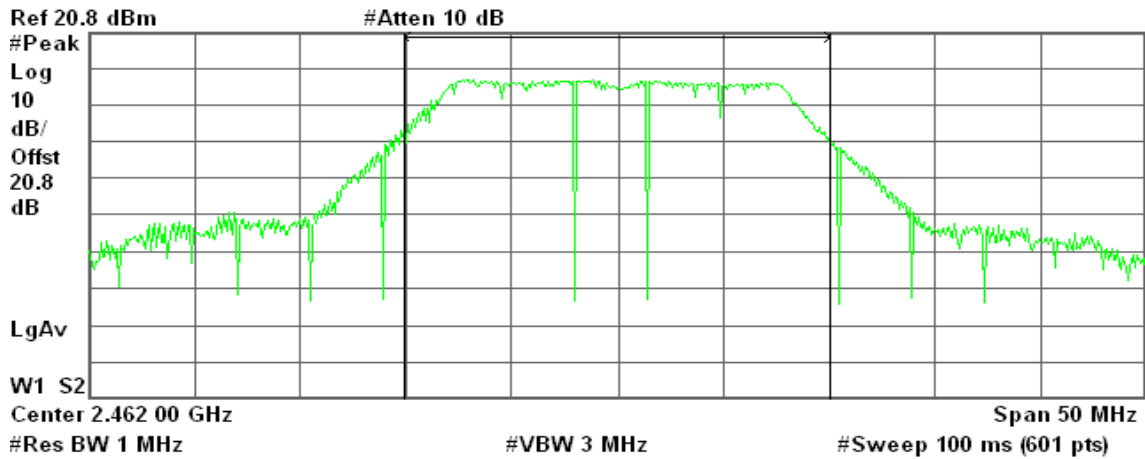

Channel Power

18.57 dBm / 20.0000 MHz

Power Spectral Density

-54.44 dBm/Hz



IEEE 802.11a mode

CH Low

Agilent 11:43:56 Sep 29, 2009

R T

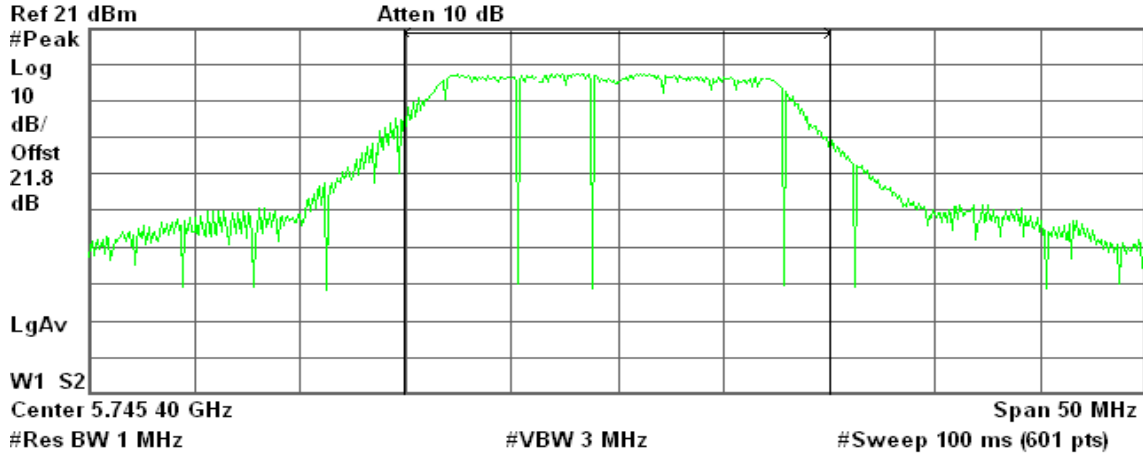

Channel Power

19.28 dBm / 20.0000 MHz

Power Spectral Density

-53.73 dBm/Hz

CH Mid

Agilent 11:46:50 Sep 29, 2009

R T

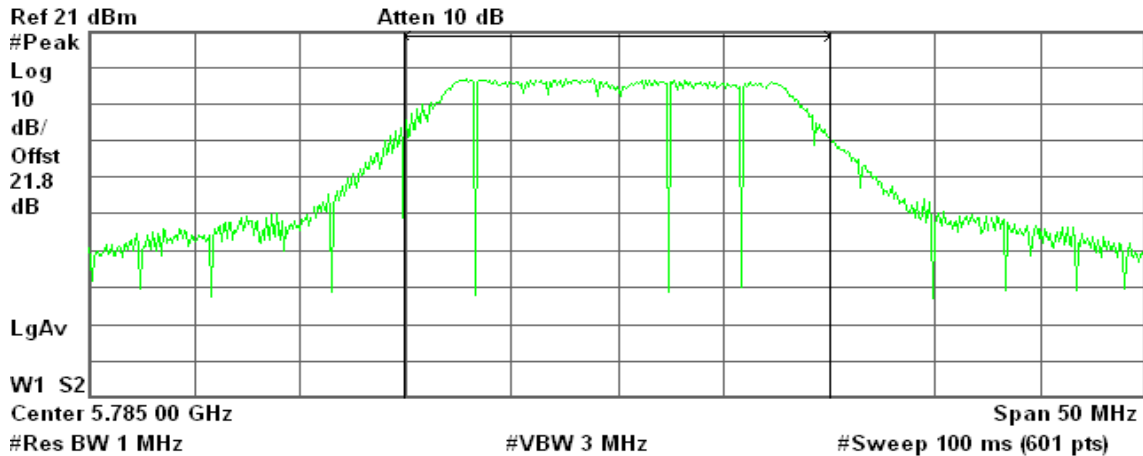

Channel Power

18.66 dBm / 20.0000 MHz

Power Spectral Density

-54.35 dBm/Hz



CH High

Agilent 11:47:58 Sep 29, 2009

R T

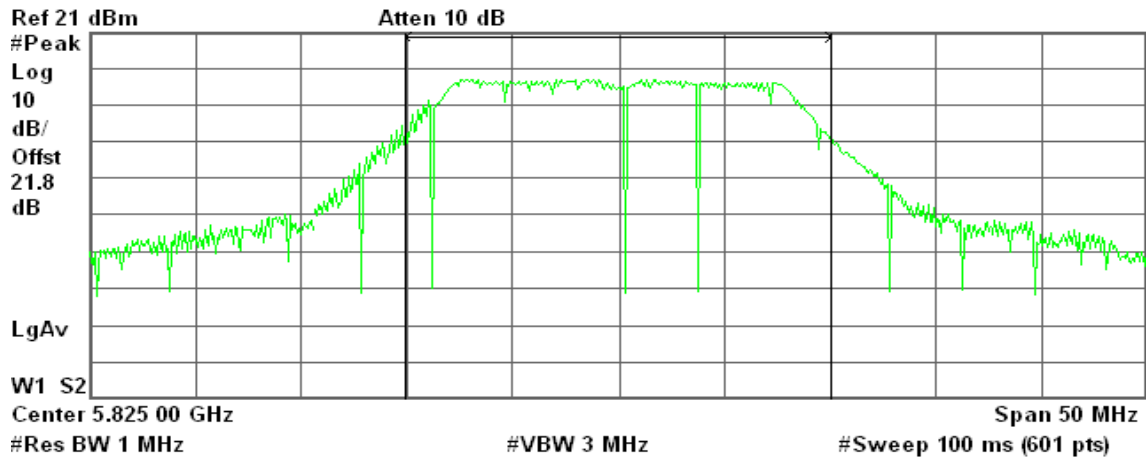

Channel Power

18.88 dBm / 20.0000 MHz

Power Spectral Density

-54.13 dBm/Hz



7.3 AVERAGE POWER

LIMIT

None; for reporting purposes only.

Test Configuration

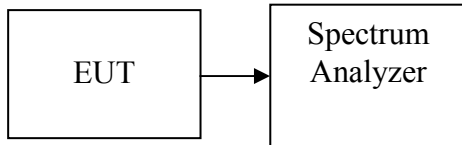

TEST PROCEDURE

The transmitter output is connected to the Spectrum analyzer. The Spectrum analyzer is set to the average power detection.

TEST RESULTS

No non-compliance noted.



Test Data

Test mode: IEEE 802.11b

Channel	Frequency (MHz)	Output Power (dBm)	Output Power (W)
Low	2412	16.36	0.0433
Mid	2437	16.50	0.0447
High	2462	15.69	0.0371

Test mode: IEEE 802.11g

Channel	Frequency (MHz)	Output Power (dBm)	Output Power (W)
Low	2412	11.23	0.0133
Mid	2437	15.14	0.0327
High	2462	11.00	0.0126

Test mode: IEEE 802.11a

Channel	Frequency (MHz)	Output Power (dBm)	Output Power (W)
Low	5745	11.21	0.0132
Mid	5785	11.57	0.0144
High	5825	11.55	0.0143



Test Plot

IEEE 802.11b mode

CH Low

Agilent 10:23:37 Sep 29, 2009

R T

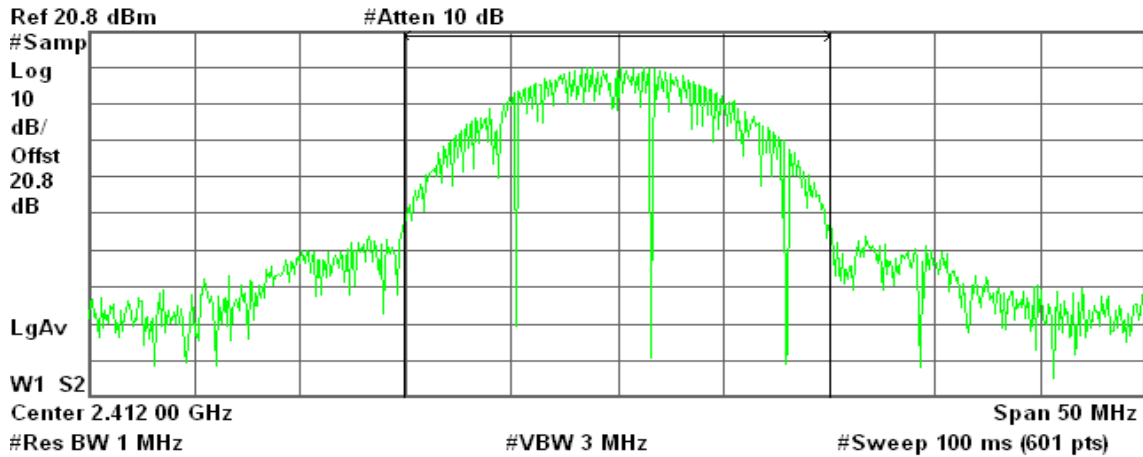

Channel Power

16.36 dBm / 20.0000 MHz

Power Spectral Density

-56.65 dBm/Hz

CH Mid

Agilent 10:25:24 Sep 29, 2009

R T

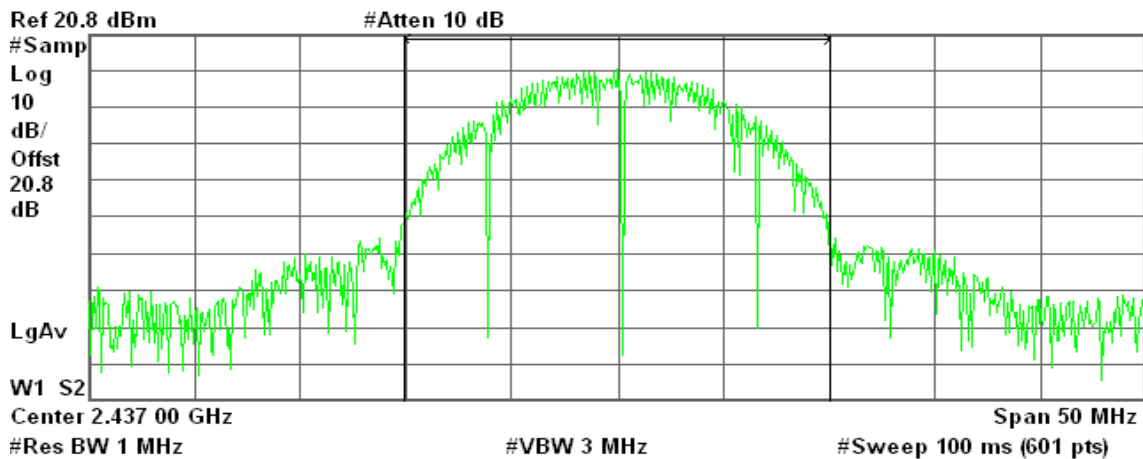

Channel Power

16.50 dBm / 20.0000 MHz

Power Spectral Density

-56.51 dBm/Hz



CH High

Agilent 10:36:00 Sep 29, 2009

R T

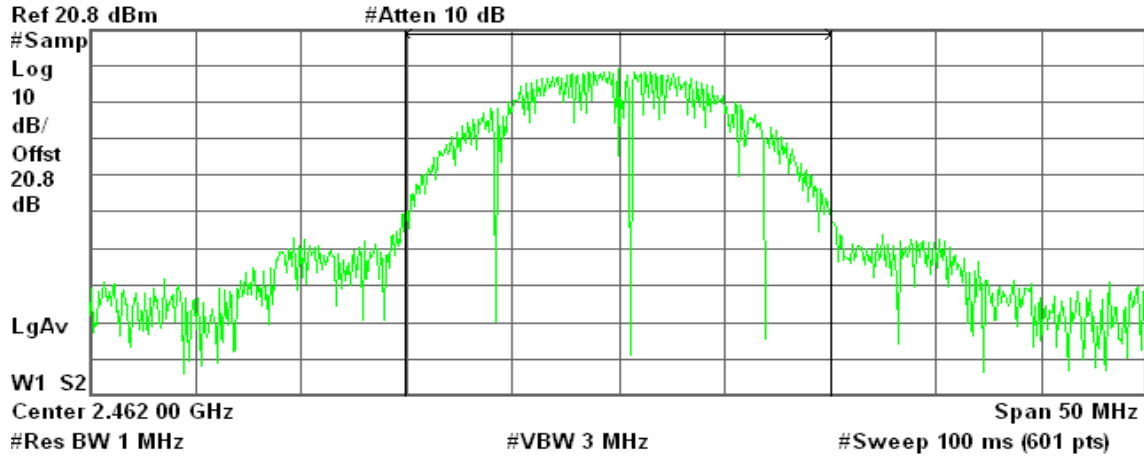

Channel Power

15.69 dBm / 20.0000 MHz

Power Spectral Density

-57.32 dBm/Hz

IEEE 802.11g mode

CH Low

Agilent 10:41:19 Sep 29, 2009

R T

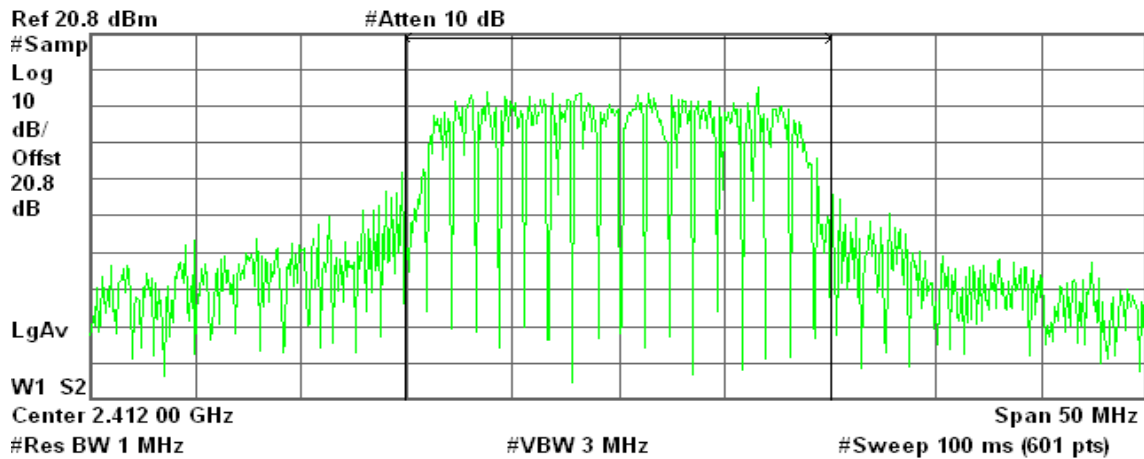

Channel Power

11.23 dBm / 20.0000 MHz

Power Spectral Density

-61.78 dBm/Hz



CH Mid

Agilent 10:52:57 Sep 29, 2009

R T

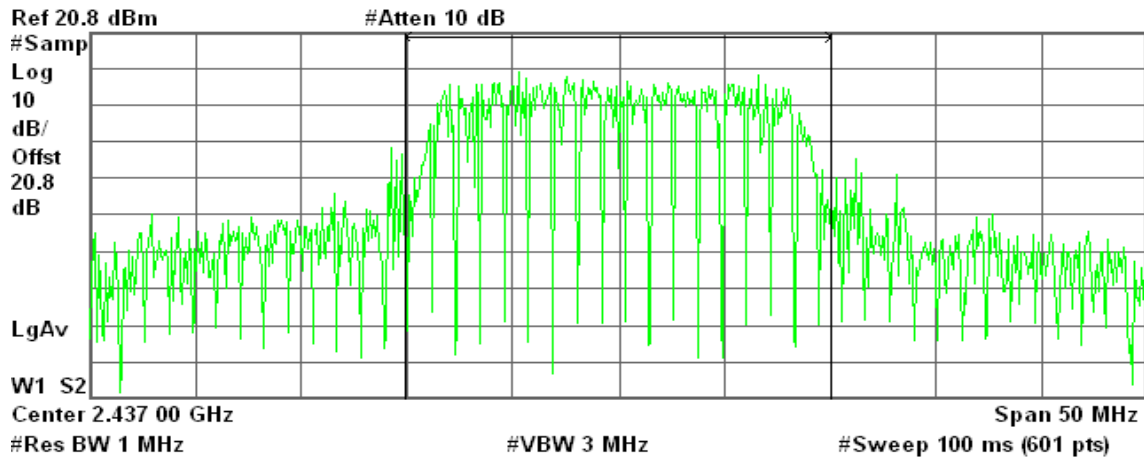

Channel Power

15.14 dBm / 20.0000 MHz

Power Spectral Density

-57.87 dBm/Hz

CH High

Agilent 10:56:48 Sep 29, 2009

R T

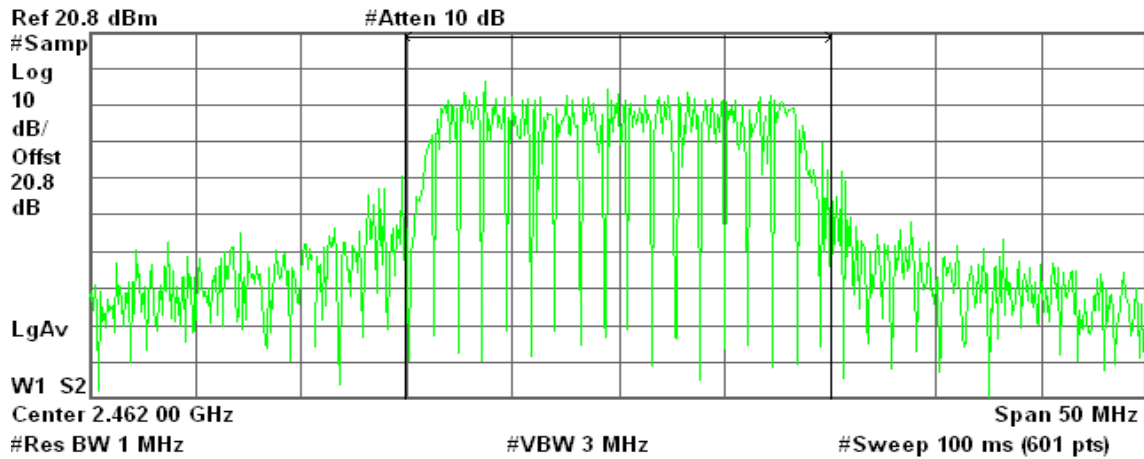

Channel Power

11.00 dBm / 20.0000 MHz

Power Spectral Density

-62.01 dBm/Hz



IEEE 802.11a mode

CH Low

Agilent 11:44:43 Sep 29, 2009

R T

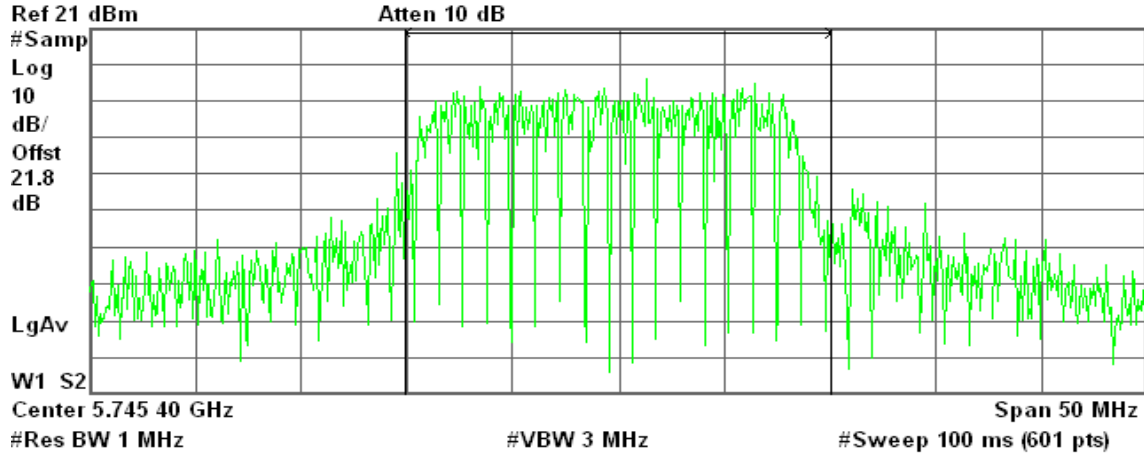

Channel Power

11.21 dBm / 20.0000 MHz

Power Spectral Density

-61.80 dBm/Hz

CH Mid

Agilent 11:46:05 Sep 29, 2009

R T

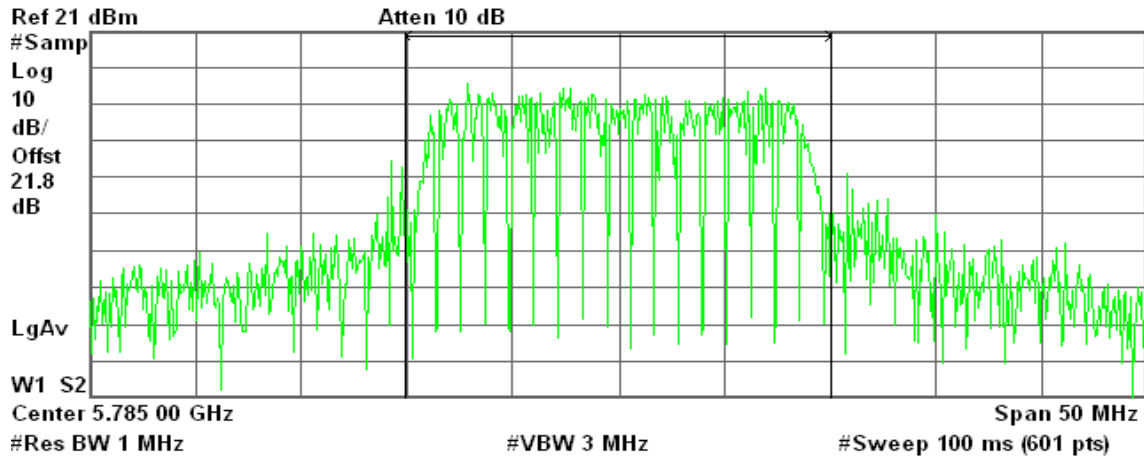

Channel Power

11.57 dBm / 20.0000 MHz

Power Spectral Density

-61.44 dBm/Hz



CH High

Agilent 11:48:38 Sep 29, 2009

R T

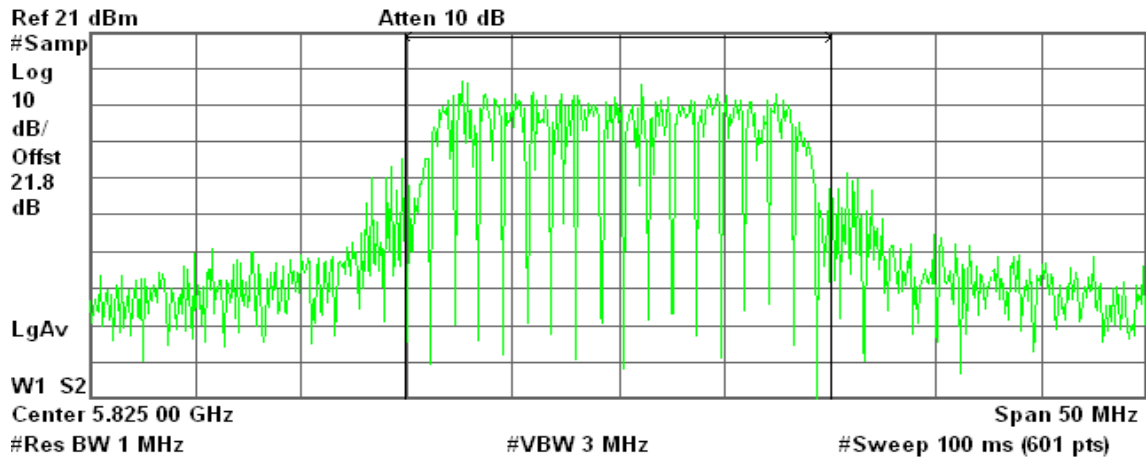

Channel Power

11.55 dBm / 20.0000 MHz

Power Spectral Density

-61.46 dBm/Hz

7.4 BAND EDGES MEASUREMENT

LIMIT

According to §15.247(d), in any 100 kHz bandwidth outside the frequency bands in which the spread spectrum intentional radiator is operating, the radio frequency power that is produced by the intentional radiator shall be at least 20 dB below that in the 100 kHz bandwidth within the band that contains the highest level of the desired power, based on either an RF conducted or a radiated measurement, provided the transmitter demonstrates compliance with the peak conducted power limits. In addition, radiated emissions which fall in the restricted bands, as defined in §15.205(a), must also comply with the radiated emission limits specified in 15.209(a) (see Section 15.205(c)).

Test Configuration

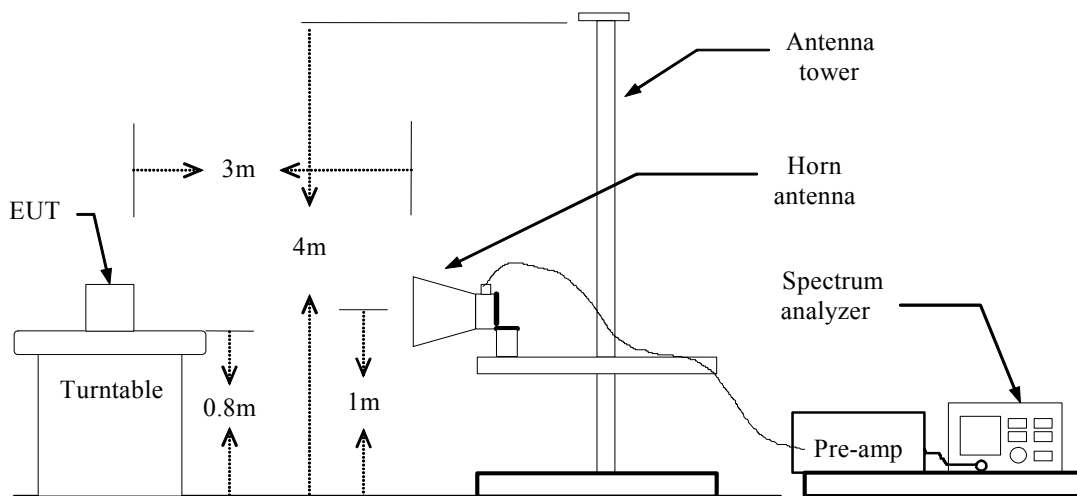

TEST PROCEDURE

1. The EUT is placed on a turntable, which is 0.8m above the ground plane.
2. The turntable shall be rotated for 360 degrees to determine the position of maximum emission level.
3. EUT is set 3m away from the receiving antenna, which is varied from 1m to 4m to find out the highest emission.
4. Set the spectrum analyzer in the following setting in order to capture the lower and upper band-edges of the emission:
 - (a) PEAK: RBW=VBW=1MHz / Sweep=AUTO
 - (b) AVERAGE: RBW=1MHz / VBW=10Hz / Sweep=AUTO
5. Repeat the procedures until all the PEAK and AVERAGE versus POLARIZATION are measured.

TEST RESULTS

Refer to attach spectrum analyzer data chart.



Band Edges (IEEE 802.11b mode / CH Low)

Detector mode: Peak

Polarity: Vertical

Agilent

R T

Mkr1 2.390 0 GHz
57.26 dB μ V

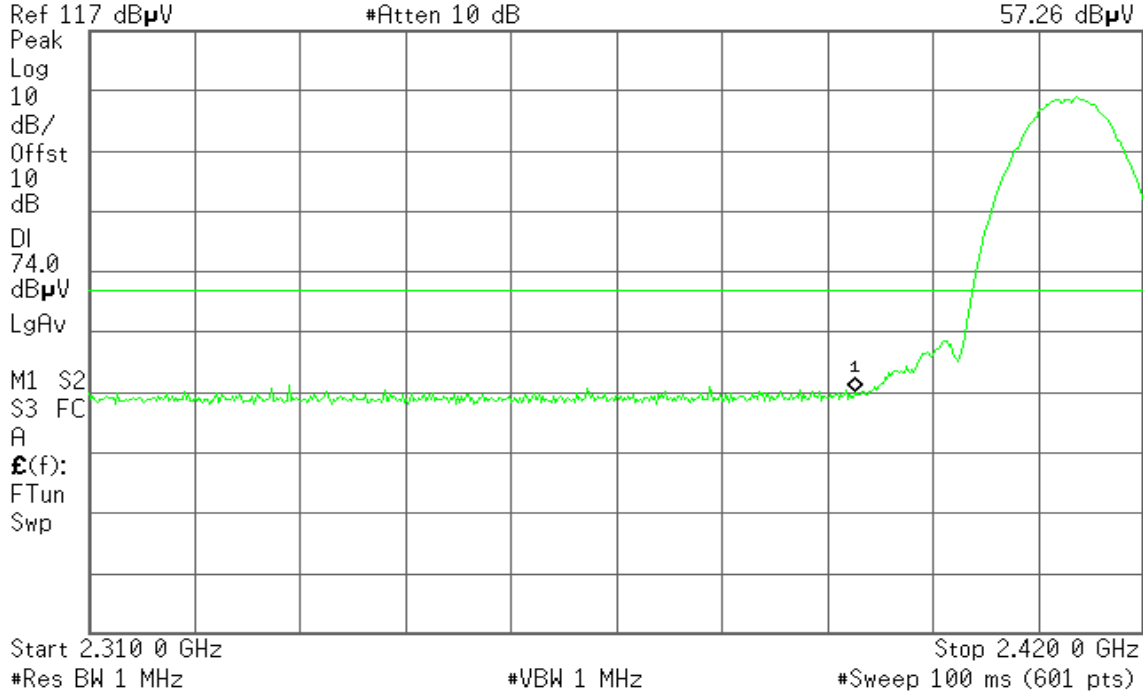

Detector mode: Average

Polarity: Vertical

Agilent

R T

Mkr1 2.390 0 GHz
44.57 dB μ V

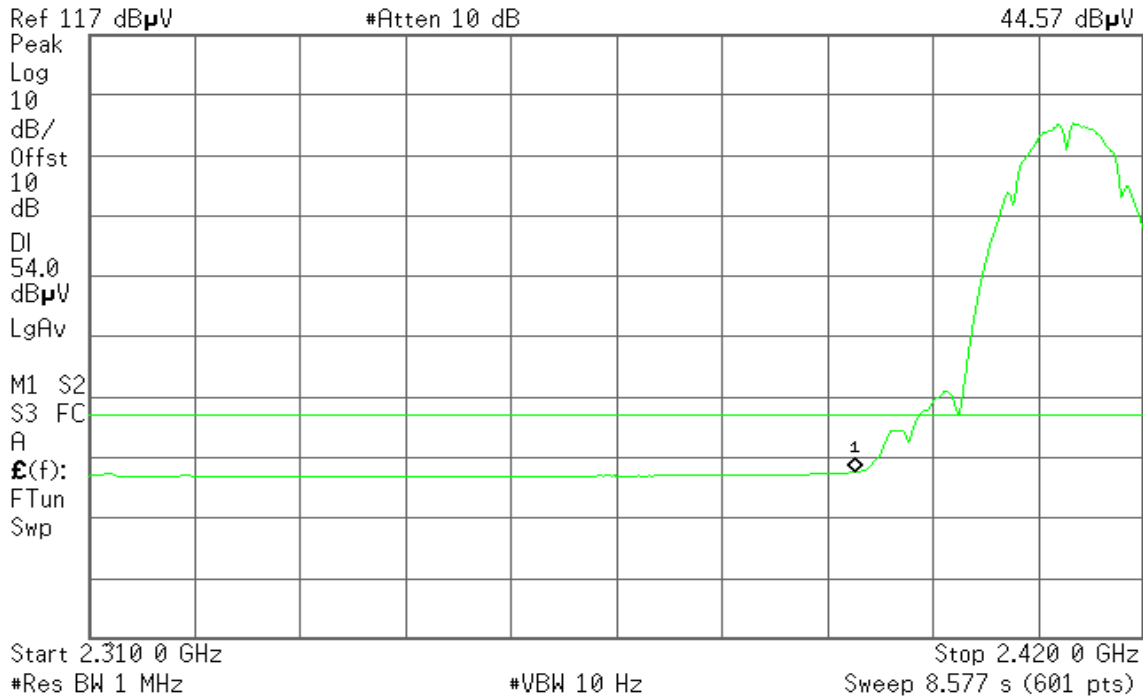



Detector mode: Peak

Polarity: Horizontal

Agilent

R T

Mkr1 2.390 0 GHz
58.26 dBμV

Ref 117 dBμV

#Atten 10 dB

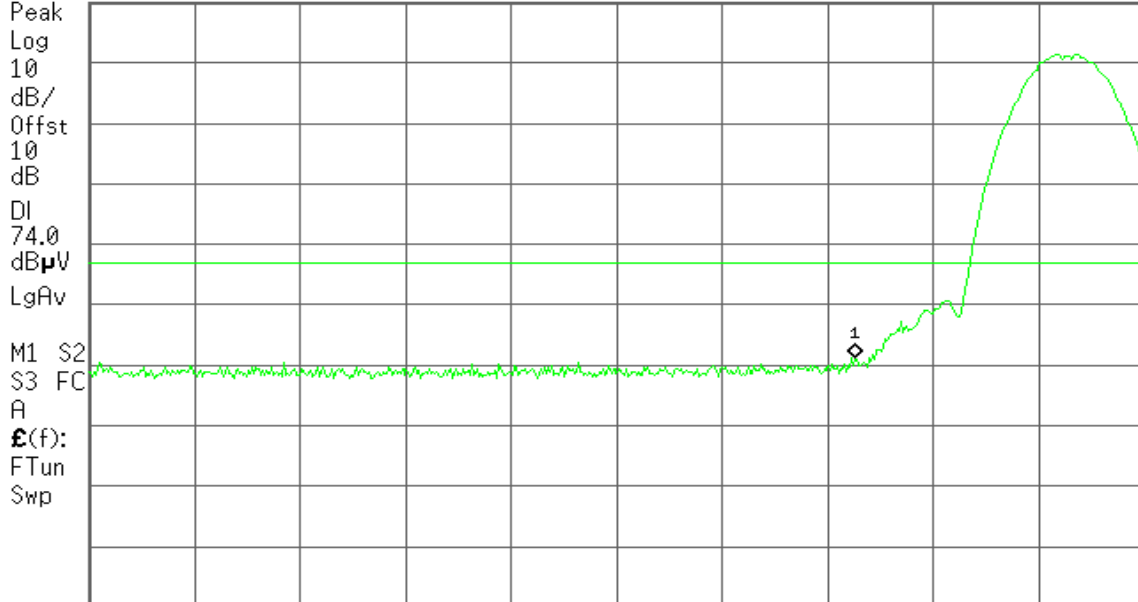

Start 2.310 0 GHz

Stop 2.420 0 GHz

#Res BW 1 MHz

#VBW 1 MHz

#Sweep 100 ms (601 pts)

Detector mode: Average

Polarity: Horizontal

Agilent

R T

Mkr1 2.390 0 GHz
45.31 dBμV

Ref 117 dBμV

#Atten 10 dB

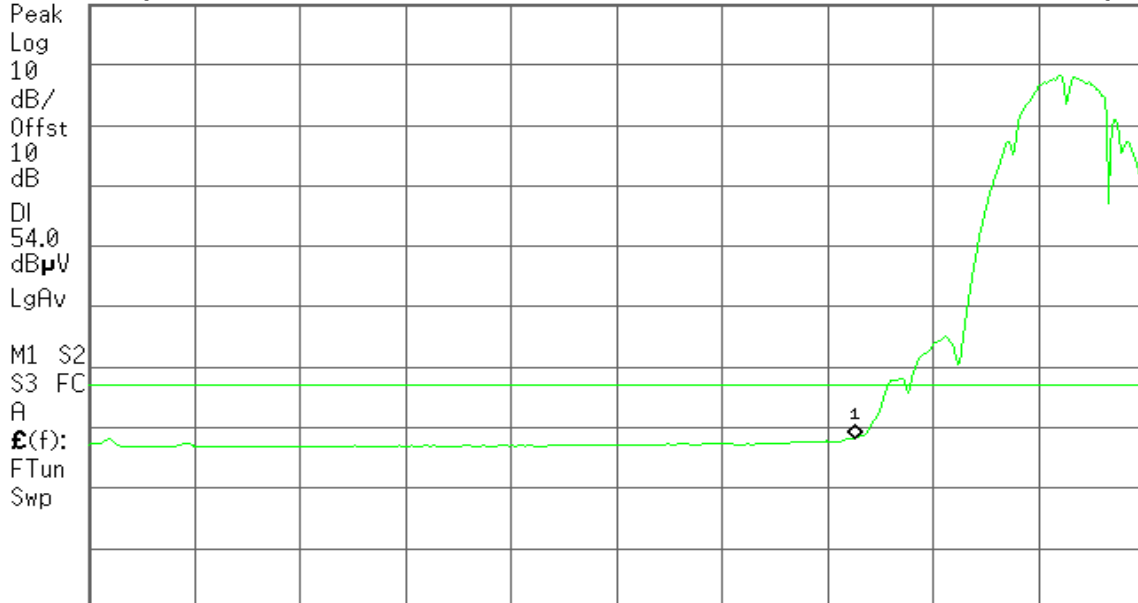

Start 2.310 0 GHz

Stop 2.420 0 GHz

#Res BW 1 MHz

#VBW 10 Hz

Sweep 8.577 s (601 pts)



Band Edges (IEEE 802.11b mode / CH High)

Detector mode: Peak

Polarity: Vertical

Agilent

R T

Mkr1 2.483 50 GHz
55.96 dBμV

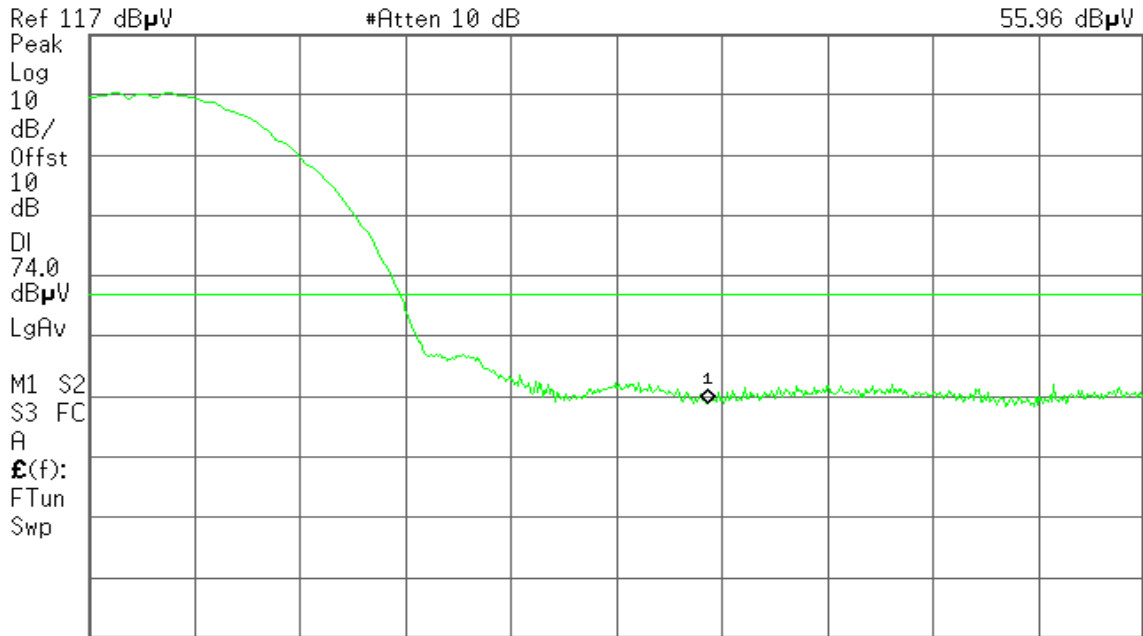

Start 2.460 00 GHz #Res BW 1 MHz #VBW 1 MHz Stop 2.500 00 GHz #Sweep 100 ms (601 pts)

Detector mode: Average

Polarity: Vertical

Agilent

R T

Mkr1 2.483 50 GHz
44.69 dBμV

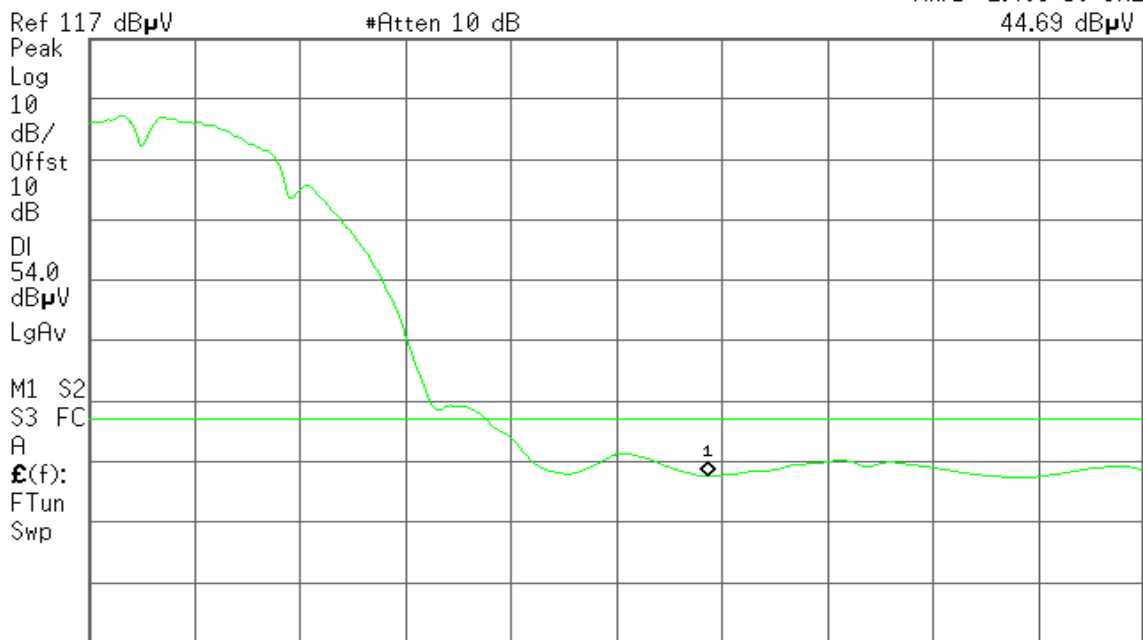

Start 2.460 00 GHz #Res BW 1 MHz #VBW 10 Hz Stop 2.500 00 GHz Sweep 3.119 s (601 pts)



Detector mode: Peak

Polarity: Horizontal

Agilent

R T

Mkr1 2.483 50 GHz
55.91 dBμV

Ref 117 dBμV

#Atten 10 dB

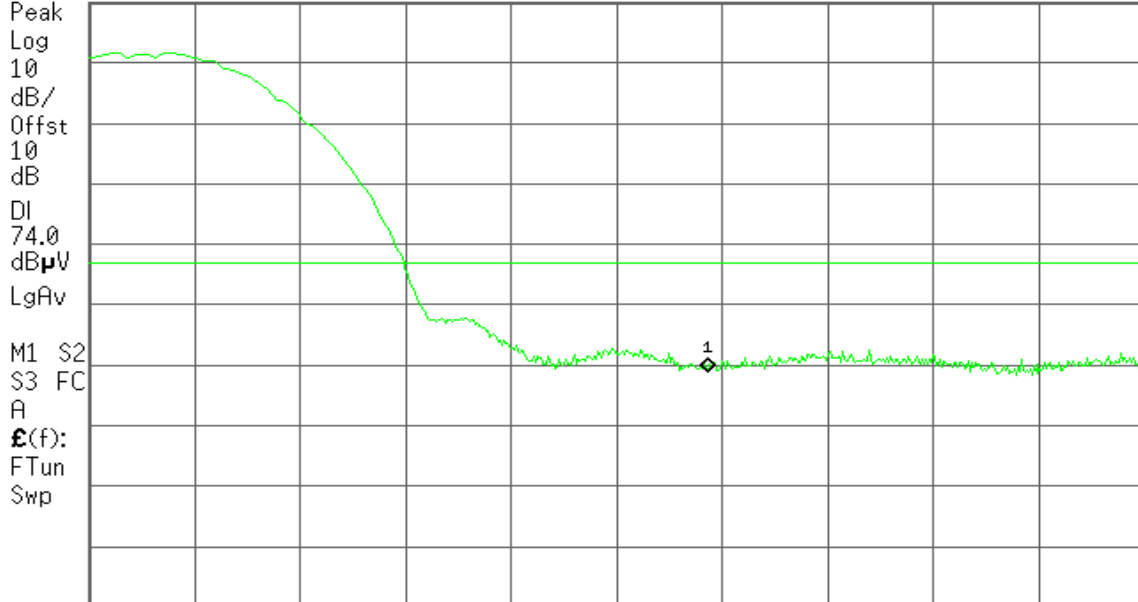

Start 2.460 00 GHz

Stop 2.500 00 GHz

#Res BW 1 MHz

#VBW 1 MHz

#Sweep 100 ms (601 pts)

Detector mode: Average

Polarity: Horizontal

Agilent

R T

Mkr1 2.483 50 GHz
44.89 dBμV

Ref 117 dBμV

#Atten 10 dB

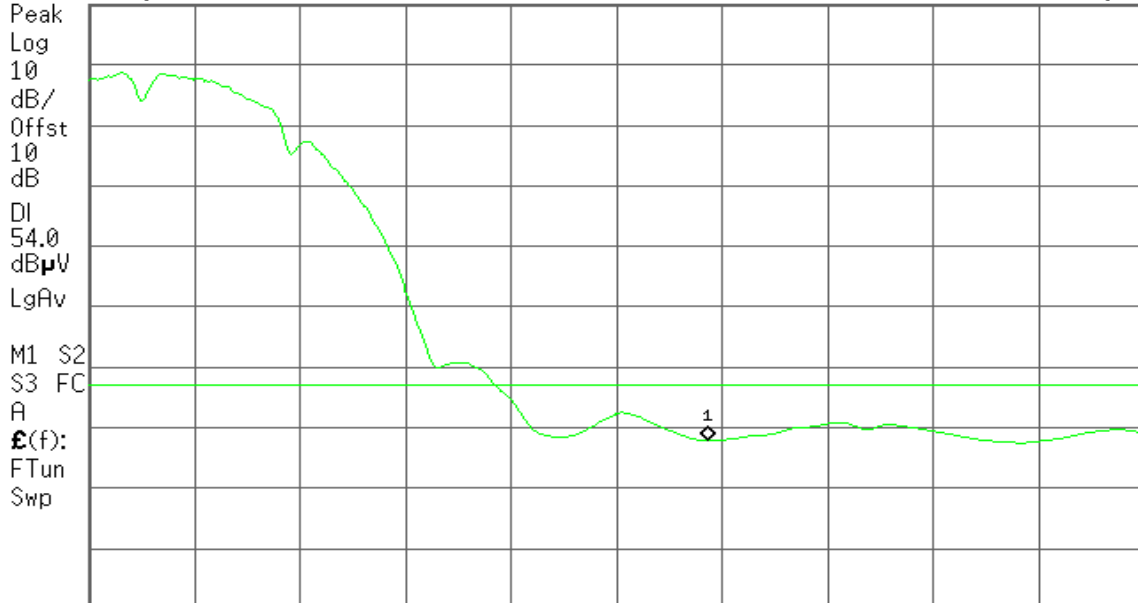

Start 2.460 00 GHz

Stop 2.500 00 GHz

#Res BW 1 MHz

#VBW 10 Hz

Sweep 3.119 s (601 pts)



Band Edges (IEEE 802.11g mode / CH Low)

Detector mode: Peak

Polarity: Vertical

Agilent

R T

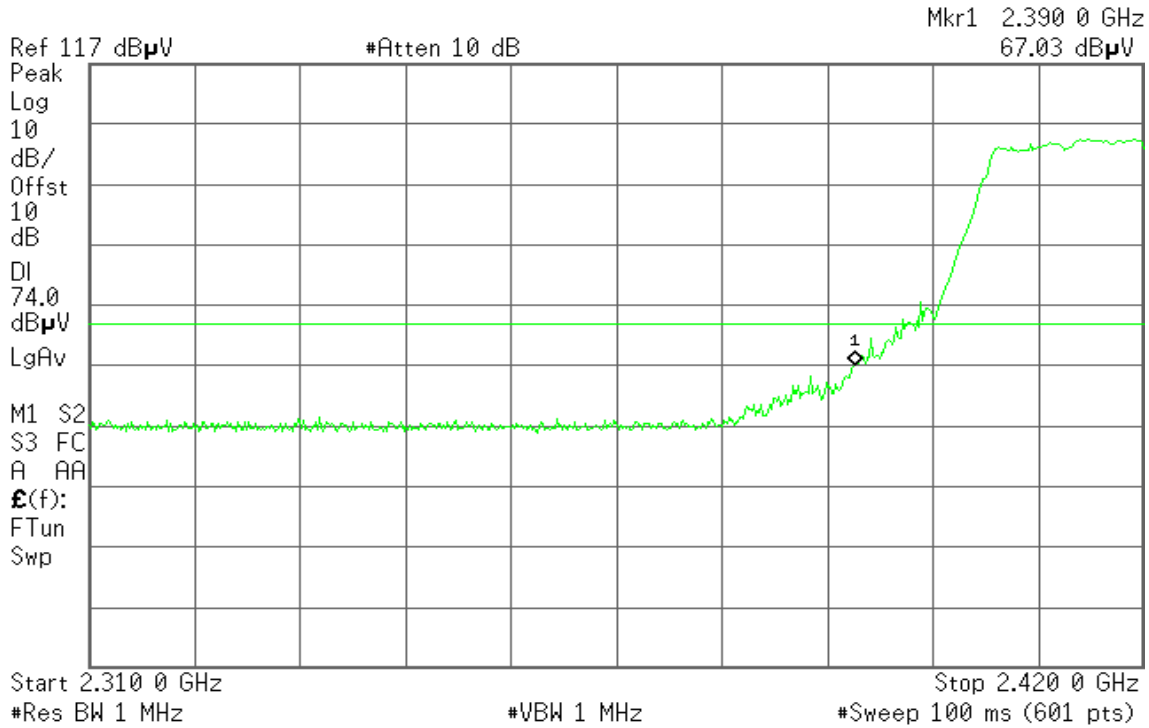

Detector mode: Average

Polarity: Vertical

Agilent

R T

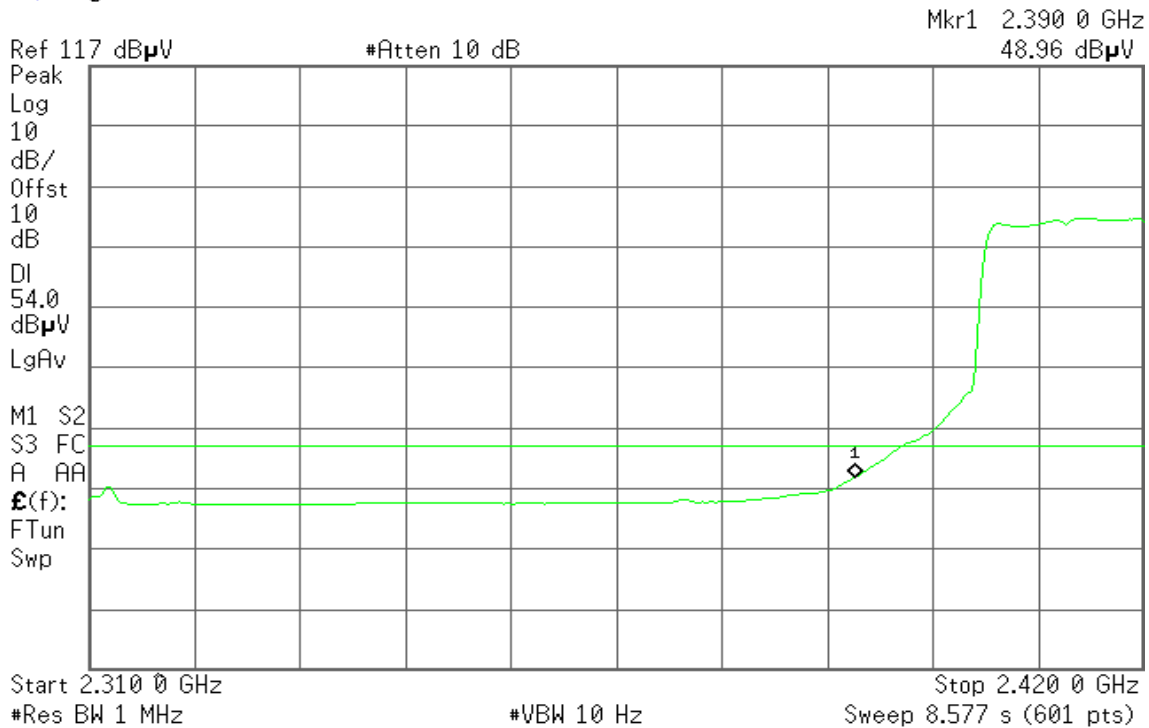



Detector mode: Peak

Polarity: Horizontal

Agilent

R T

Mkr1 2.390 0 GHz
69.53 dBμV

Ref 117 dBμV

#Atten 10 dB

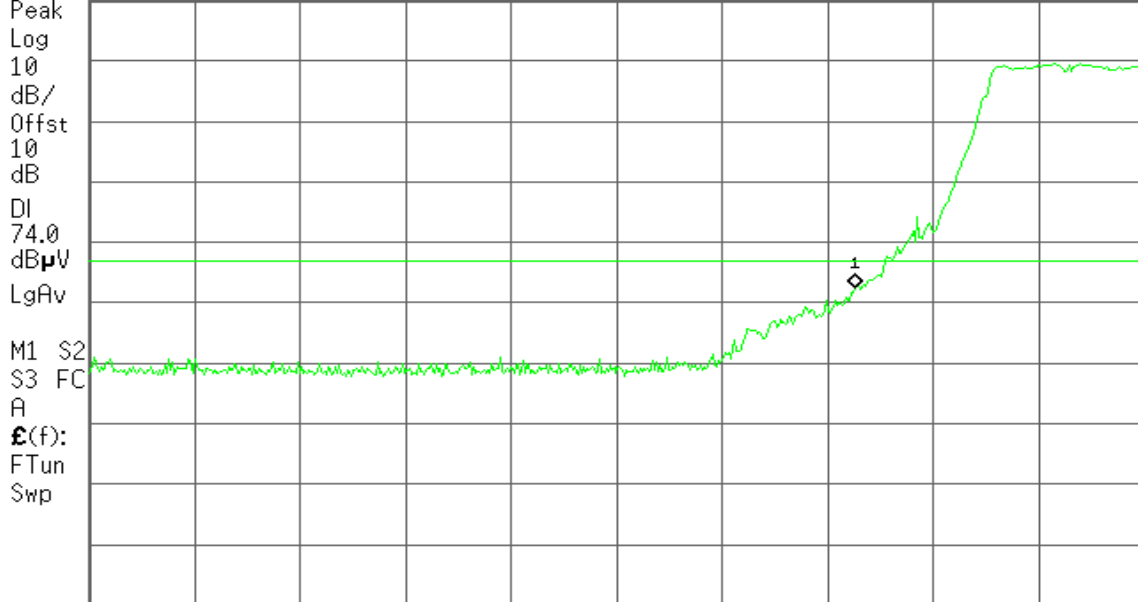

Start 2.310 0 GHz

#Res BW 1 MHz

#VBW 1 MHz

Stop 2.420 0 GHz

#Sweep 100 ms (601 pts)

Detector mode: Average

Polarity: Horizontal

Agilent

R T

Mkr1 2.390 0 GHz
52.19 dBμV

Ref 117 dBμV

#Atten 10 dB

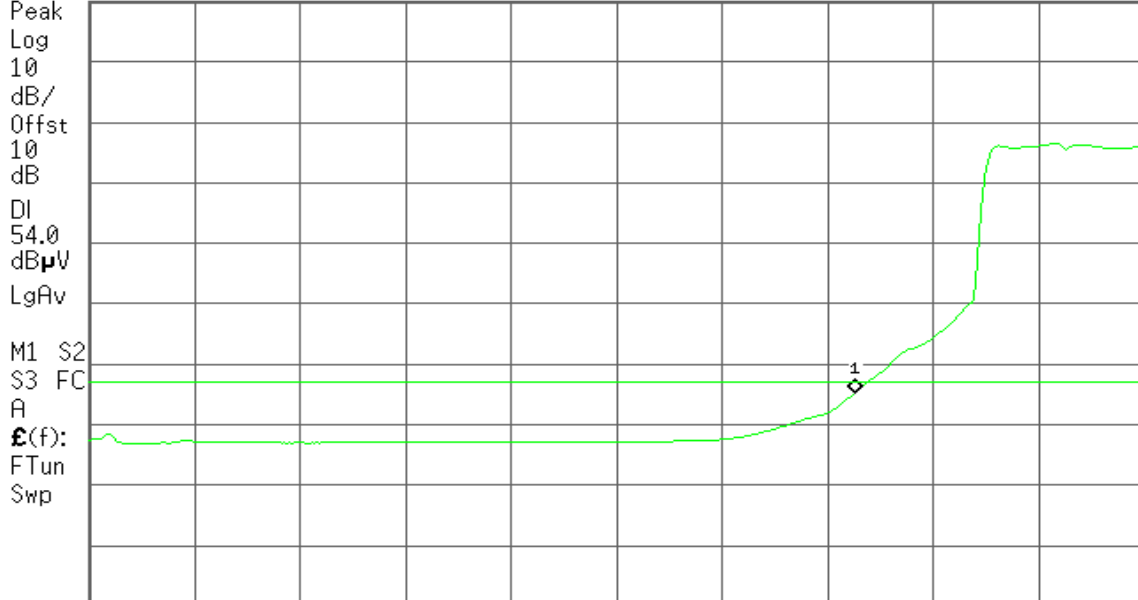

Start 2.310 0 GHz

#Res BW 1 MHz

#VBW 10 Hz

Stop 2.420 0 GHz

Sweep 8.577 s (601 pts)



Band Edges (IEEE 802.11g mode / CH High)

Detector mode: Peak

Polarity: Vertical

Agilent

R T

Mkr1 2.483 50 GHz
69.18 dBμV

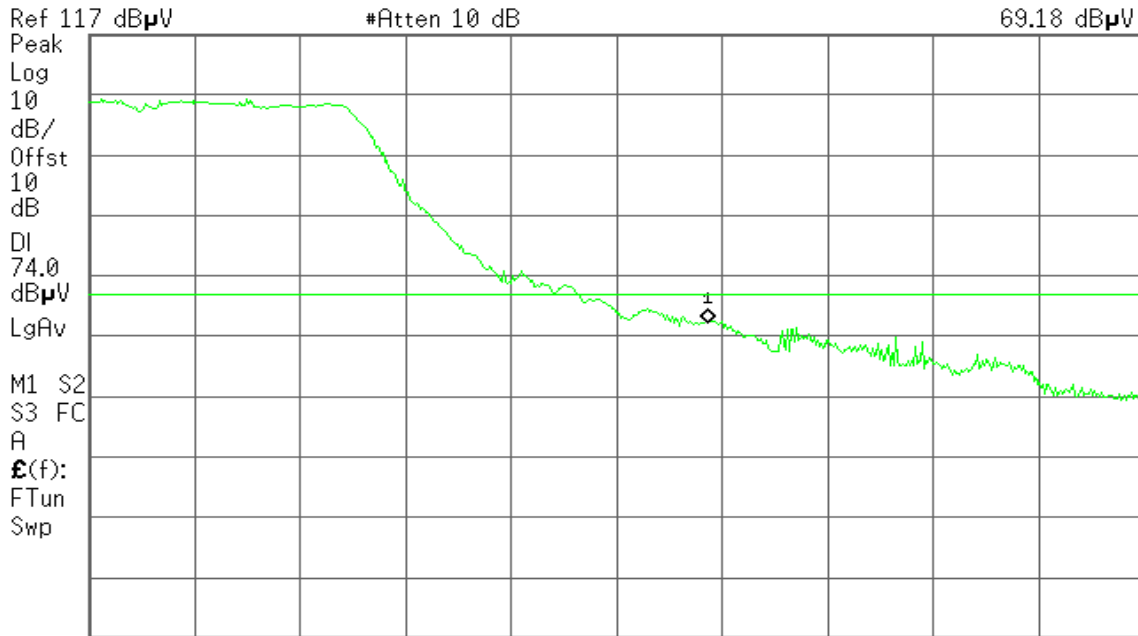

Start 2.460 00 GHz #Res BW 1 MHz #VBW 1 MHz Stop 2.500 00 GHz #Sweep 100 ms (601 pts)

Detector mode: Average

Polarity: Vertical

Agilent

R T

Mkr1 2.483 50 GHz
51.32 dBμV

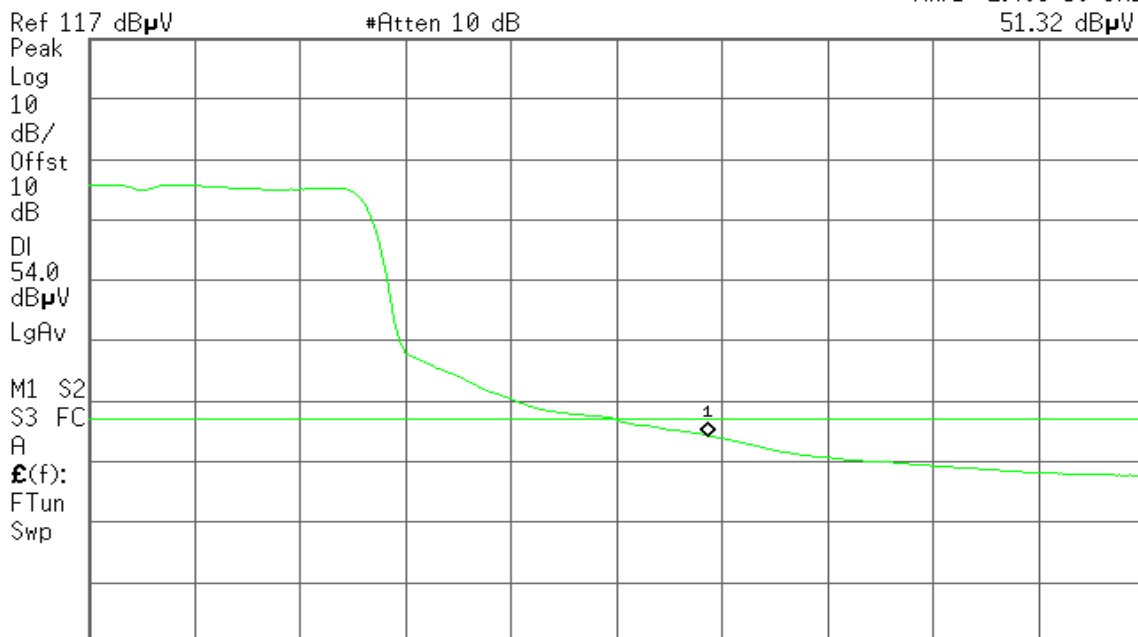

Start 2.460 00 GHz #Res BW 1 MHz #VBW 10 Hz Stop 2.500 00 GHz Sweep 3.119 s (601 pts)



Detector mode: Peak

Polarity: Horizontal

Agilent

R T

Mkr1 2.483 50 GHz
69.32 dBμV

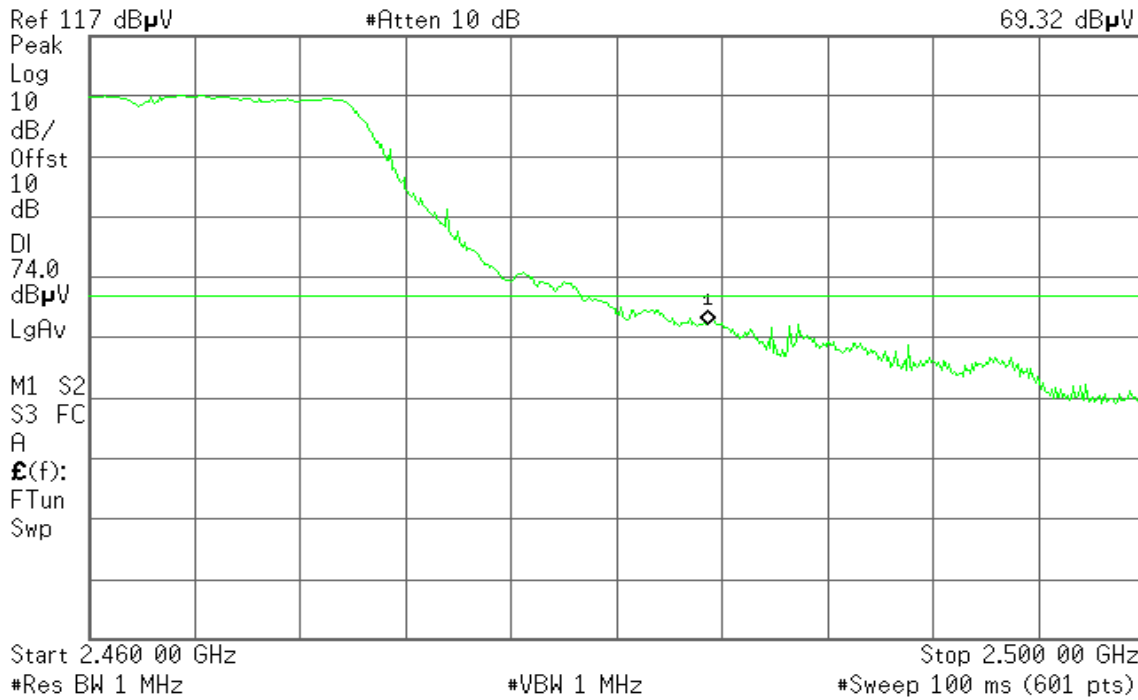

Detector mode: Average

Polarity: Horizontal

Agilent

R T

Mkr1 2.483 50 GHz
51.53 dBμV

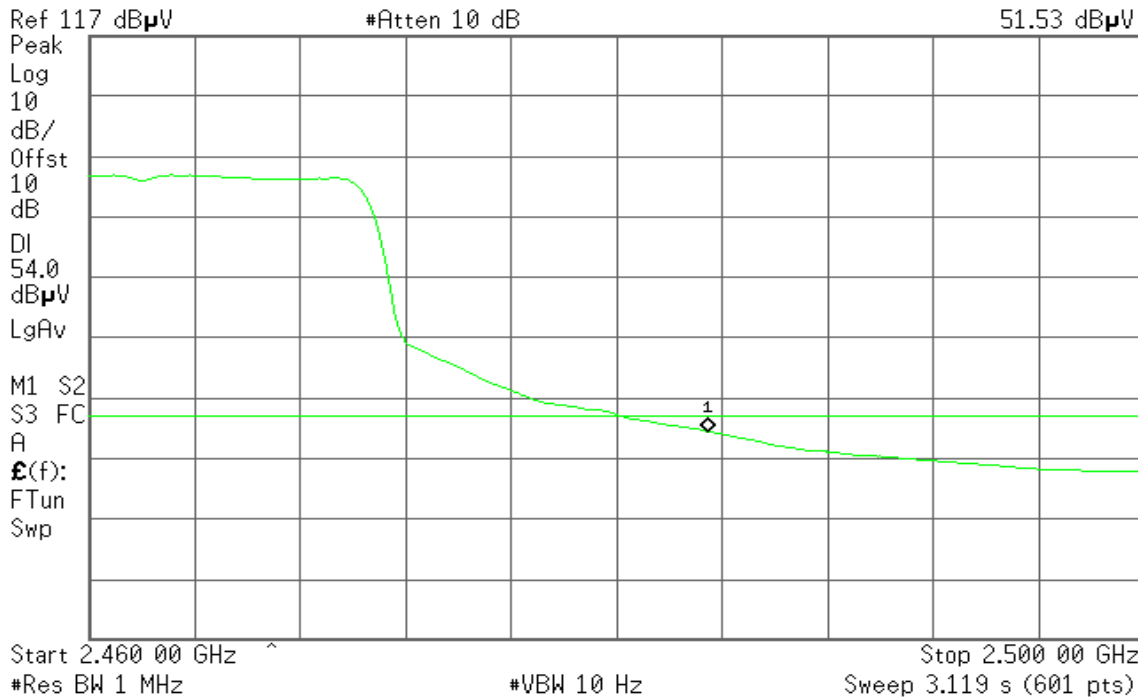

7.5 PEAK POWER SPECTRAL DENSITY

LIMIT

1. According to §15.247(e), for digitally modulated systems, the power spectral density conducted from the intentional radiator to the antenna shall not be greater than 8 dBm in any 3 kHz band during any time interval of continuous transmission.
2. According to §15.247(f), the digital modulation operation of the hybrid system, with the frequency hopping turned off, shall comply with the power density requirements of paragraph (d) of this section.

Test Configuration

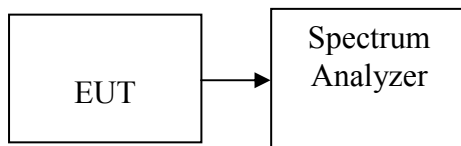

TEST PROCEDURE

1. Place the EUT on the table and set it in transmitting mode.
Remove the antenna from the EUT and then connect a low loss RF cable from the antenna port to the spectrum analyzer.
2. Set the spectrum analyzer as RBW = 3kHz, VBW = 10kHz, Span = 300kHz, Sweep=100s.
3. Record the max. reading.
4. Repeat the above procedure until the measurements for all frequencies are completed.

TEST RESULTS

No non-compliance noted



Test Data

IEEE 802.11b

Channel	Frequency (MHz)	PPSD (dBm)	Limit (dBm)	Test Result
Low	2412	-9.90	8.00	PASS
Mid	2437	-8.04		PASS
High	2462	-8.74		PASS

IEEE 802.11g

Channel	Frequency (MHz)	PPSD (dBm)	Limit (dBm)	Test Result
Low	2412	-17.40	8.00	PASS
Mid	2437	-12.22		PASS
High	2462	-15.02		PASS

IEEE 802.11a

Channel	Frequency (MHz)	PPSD (dBm)	Limit (dBm)	Test Result
Low	5745	-12.23	8.00	PASS
Mid	5785	-13.57		PASS
High	5825	-13.71		PASS



Test Plot

IEEE 802.11b mode

CH Low

Agilent 11:02:03 Sep 29, 2009

R T

Mkr1 2.409 972 6 GHz
-9.90 dBm

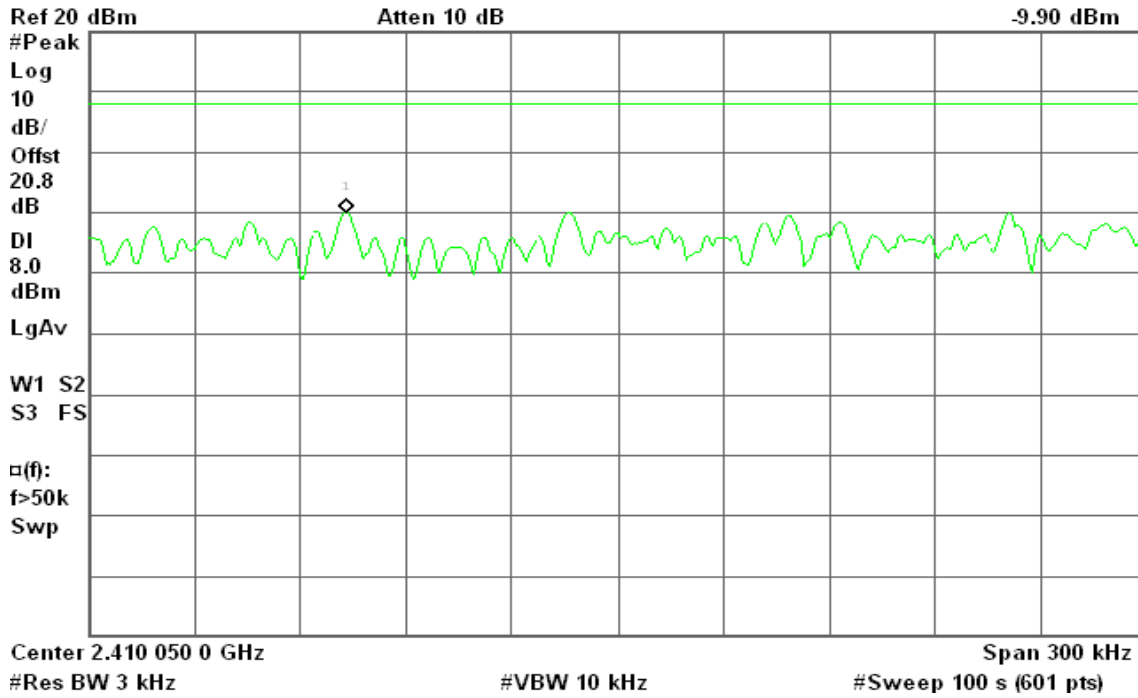

CH Mid

Agilent 11:07:50 Sep 29, 2009

R T

Mkr1 2.436 322 1 GHz
-8.04 dBm

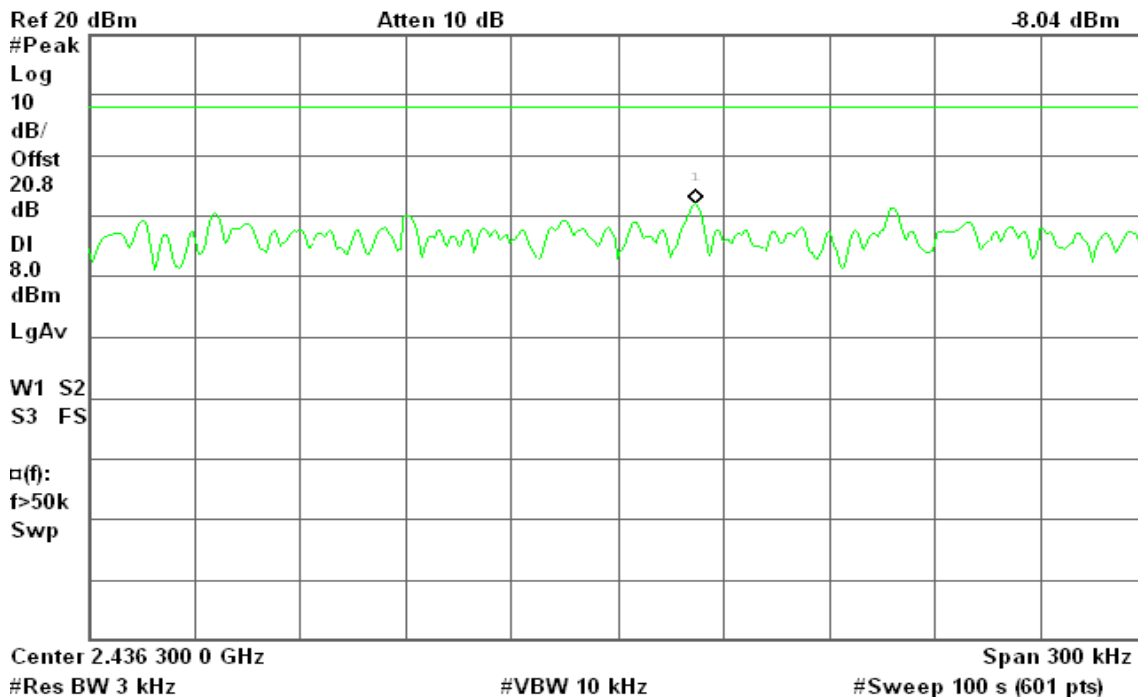



CH High

Agilent 11:17:27 Sep 29, 2009

R T

Mkr1 2.461 323 3 GHz
-8.74 dBm

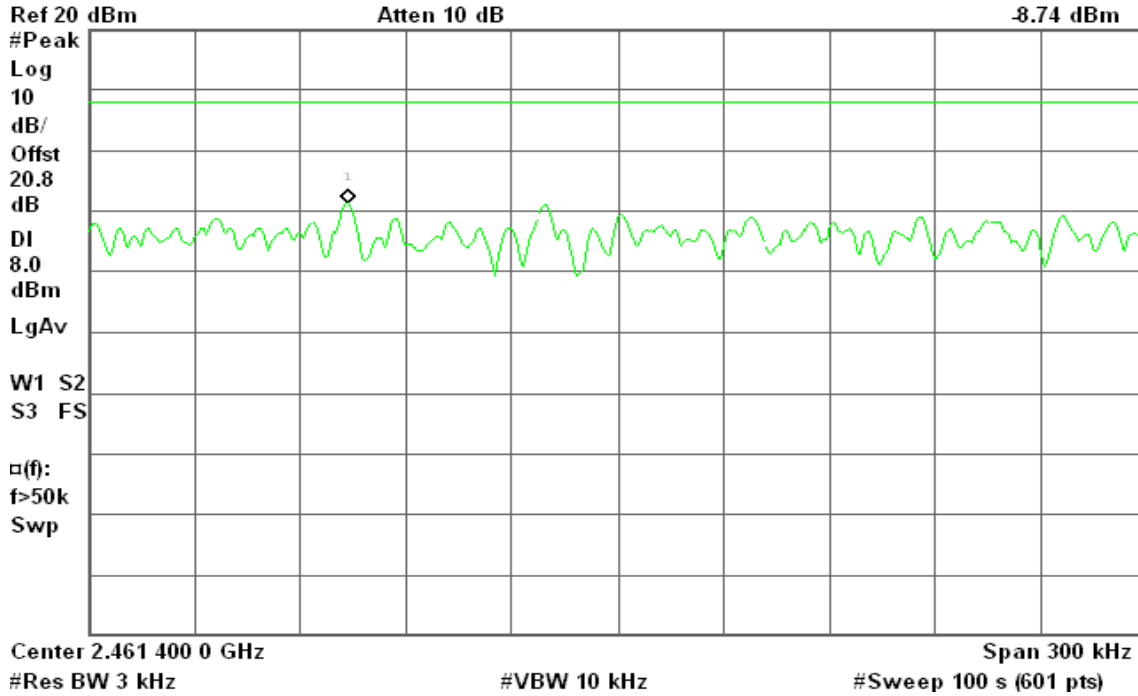

IEEE 802.11g mode

CH Low

Agilent 11:22:40 Sep 29, 2009

R T

Mkr1 2.405 419 1 GHz
-17.40 dBm

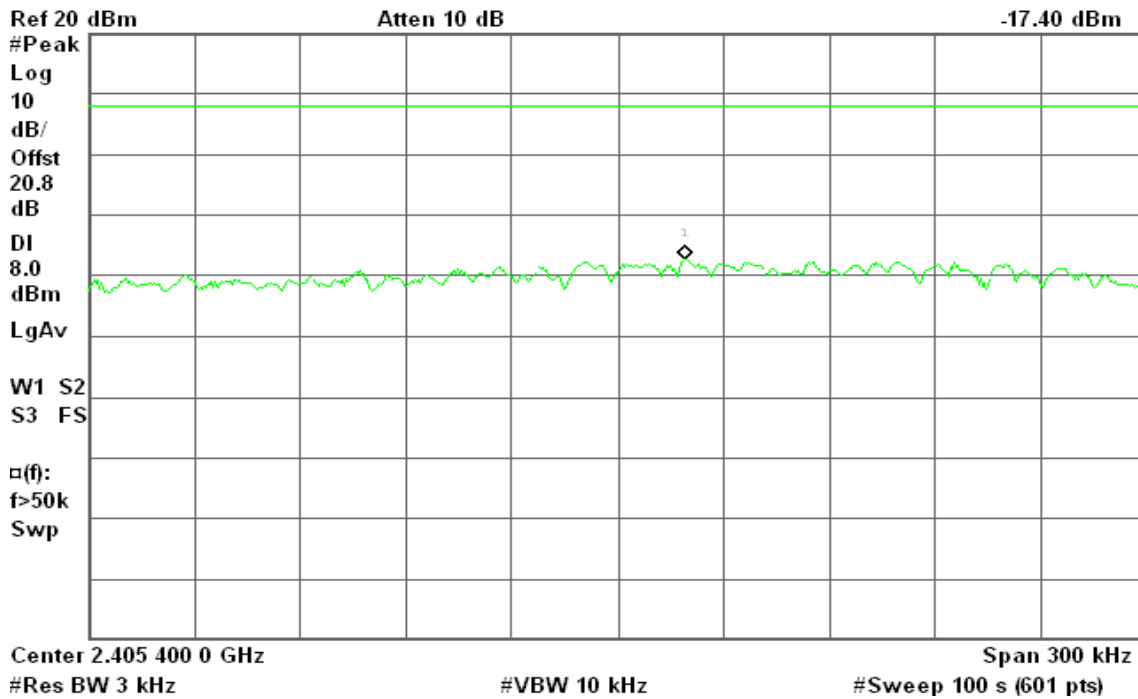



CH Mid

Agilent 11:27:58 Sep 29, 2009

R T

Mkr1 2.438 874 1 GHz
-12.22 dBm

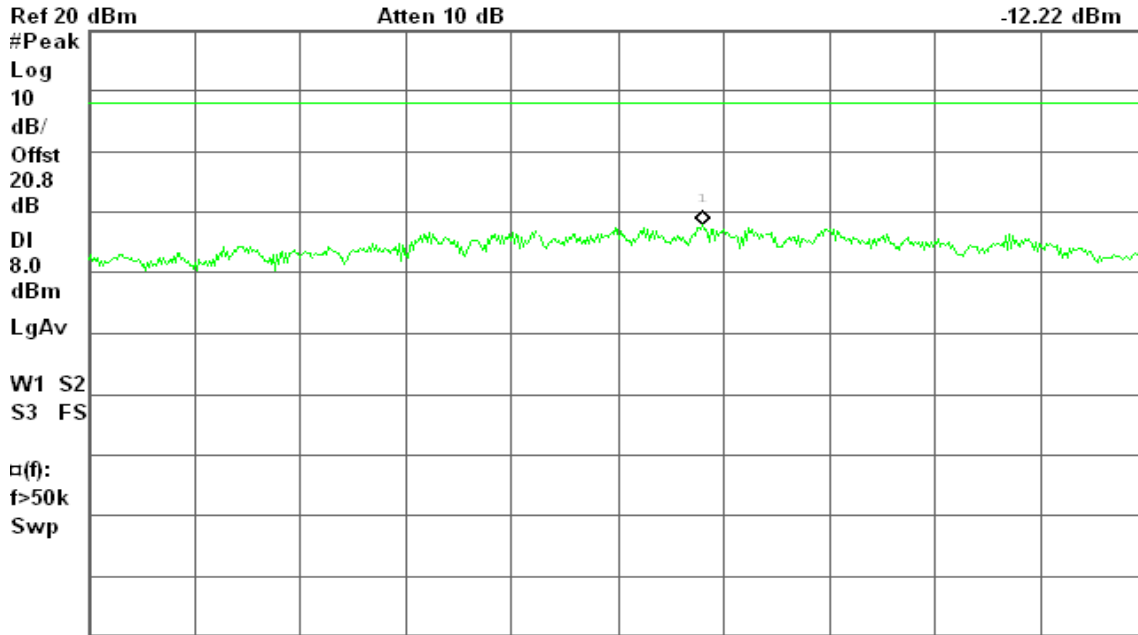

Center 2.438 850 0 GHz

Span 300 kHz

#Res BW 3 kHz

#VBW 10 kHz

#Sweep 100 s (601 pts)

CH High

Agilent 11:32:54 Sep 29, 2009

R T

Mkr1 2.463 295 7 GHz
-15.02 dBm

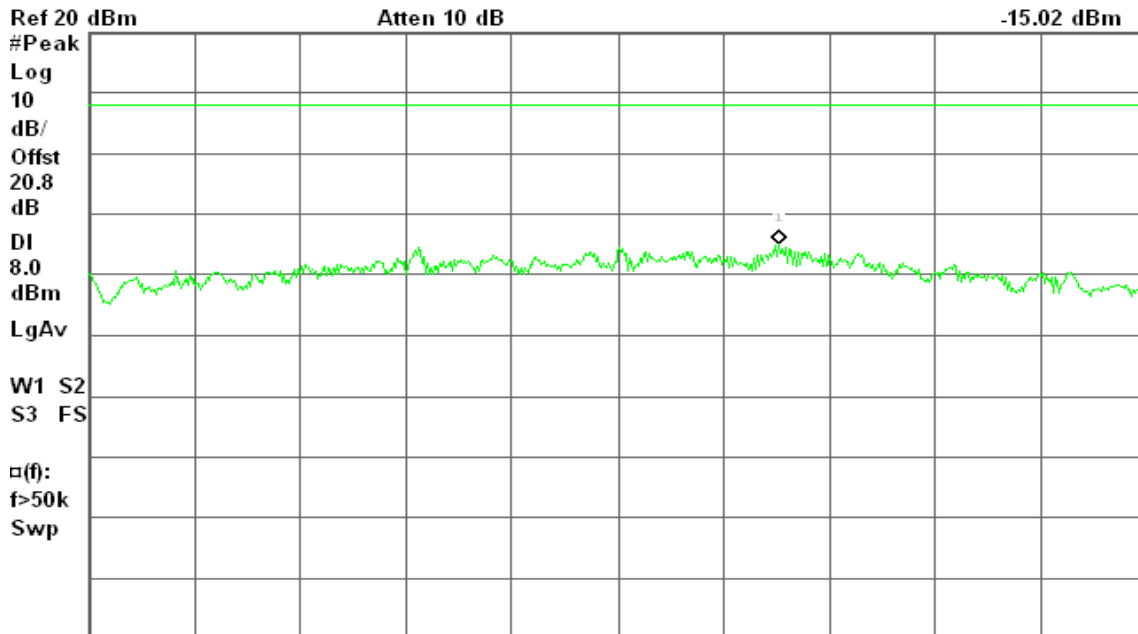

Center 2.463 250 0 GHz

Span 300 kHz

#Res BW 3 kHz

#VBW 10 kHz

#Sweep 100 s (601 pts)



IEEE 802.11a mode

CH Low

Agilent 11:58:19 Sep 29, 2009

R T

Mkr1 5.744 084 9 GHz

-12.23 dBm

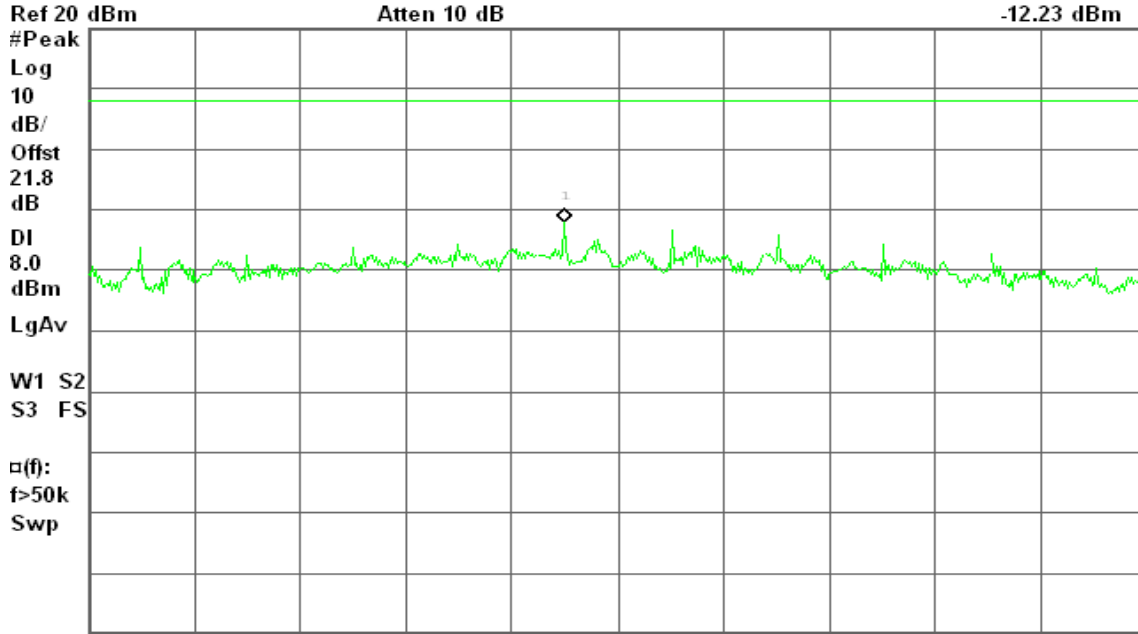

Center 5.744 100 0 GHz

#Res BW 3 kHz

#VBW 10 kHz

Span 300 kHz

#Sweep 100 s (601 pts)

CH Mid

Agilent 13:11:04 Sep 29, 2009

R T

Mkr1 5.783 446 3 GHz

-13.57 dBm

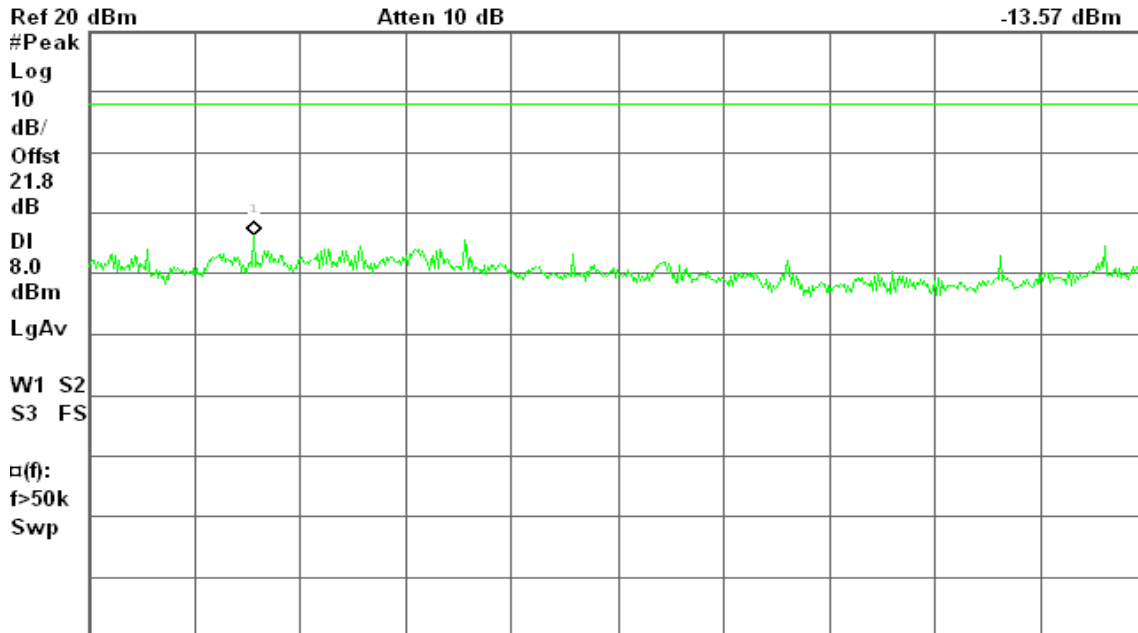

Center 5.783 550 0 GHz

#Res BW 3 kHz

#VBW 10 kHz

Span 300 kHz

#Sweep 100 s (601 pts)



CH High

Agilent 13:16:14 Sep 29, 2009

R T

Mkr1 5.816 952 0 GHz
-13.71 dBm

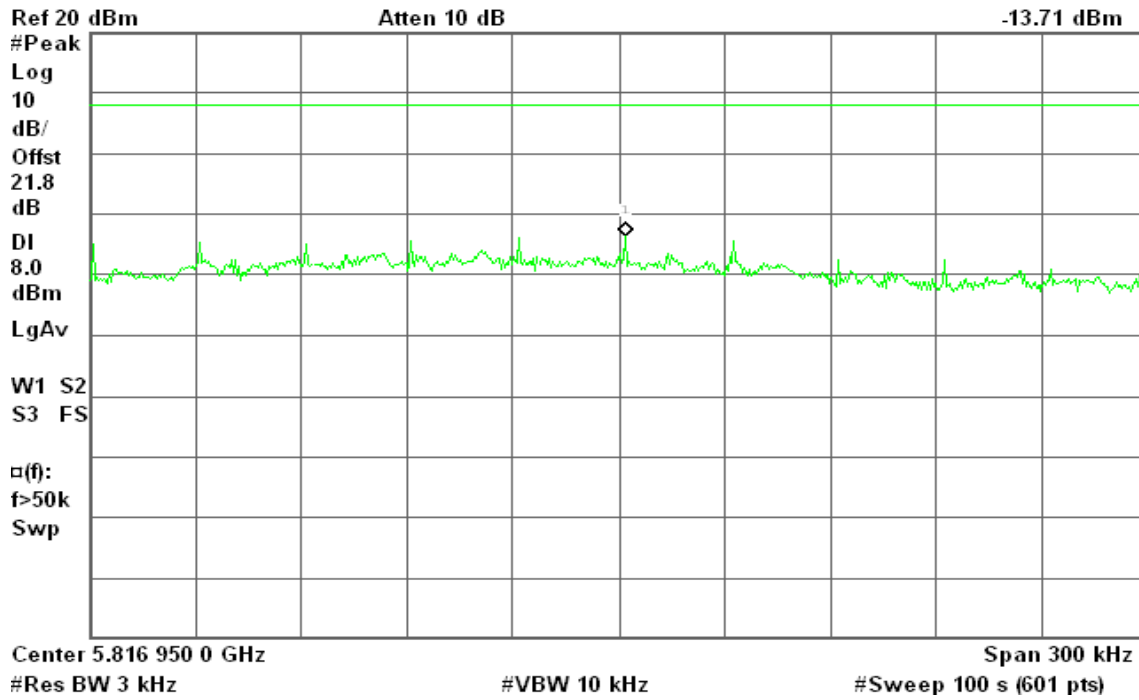



7.6 SPURIOUS EMISSIONS

7.6.1 CONDUCTED MEASUREMENT

LIMIT

According to §15.247(d), in any 100 kHz bandwidth outside the frequency bands in which the spread spectrum intentional radiator is operating, the radio frequency power that is produced by the intentional radiator shall be at least 20 dB below that in the 100 kHz bandwidth within the band that contains the highest level of the desired power, based on either an RF conducted or a radiated measurement, provided the transmitter demonstrates compliance with the peak conducted power limits. In addition, radiated emissions which fall in the restricted bands, as defined in §15.205(a), must also comply with the radiated emission limits specified in 15.209(a) (see Section 15.205(c)).

Test Configuration

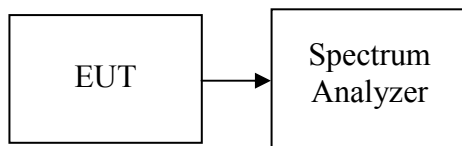

TEST PROCEDURE

Conducted RF measurements of the transmitter output were made to confirm that the EUT antenna port conducted emissions meet the specified limit and to identify any spurious signals that require further investigation or measurements on the radiated emissions site.

The transmitter output is connected to the spectrum analyzer. The resolution bandwidth is set to 100 kHz. The video bandwidth is set to 100 kHz.

Measurements are made over the 30MHz to 26GHz range for IEEE 802.11b/g, 30MHz to 40GHz range for IEEE 802.11a with the transmitter set to the lowest, middle, and highest channels.

TEST RESULTS

No non-compliance noted.



Test Plot

IEEE 802.11b / CH Low

Agilent 11:03:08 Sep 29, 2009

R T

Mkr1 2.42 GHz
4.92 dBm

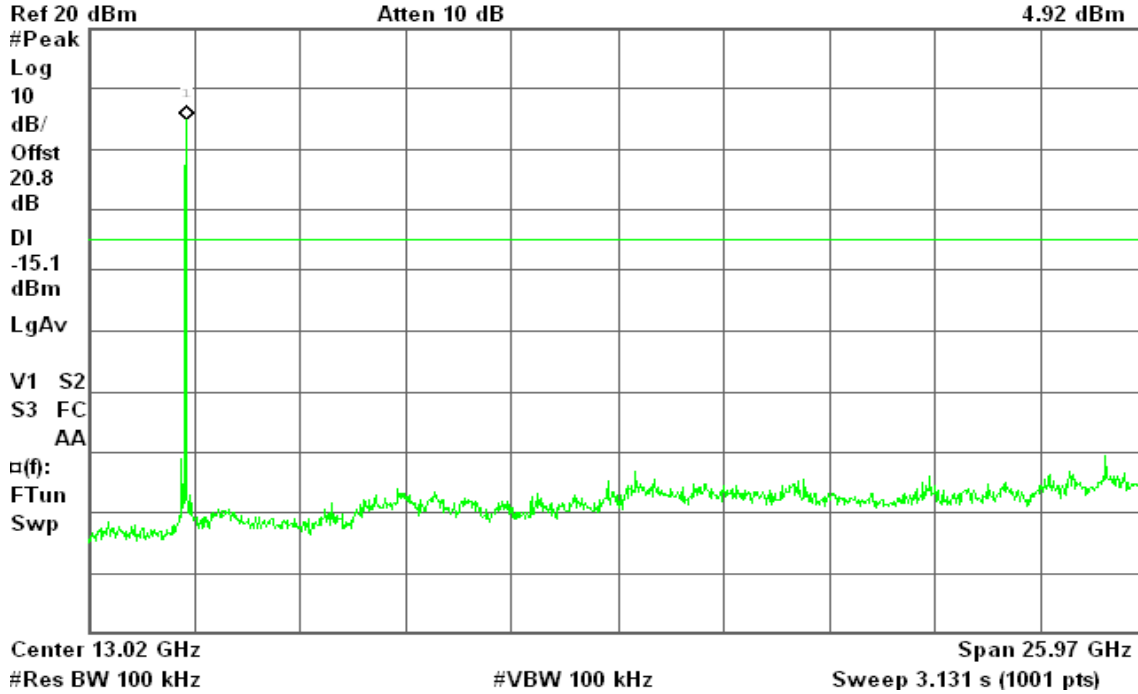

IEEE 802.11b / CH Mid

Agilent 11:09:01 Sep 29, 2009

R T

Mkr1 2.45 GHz
5.07 dBm

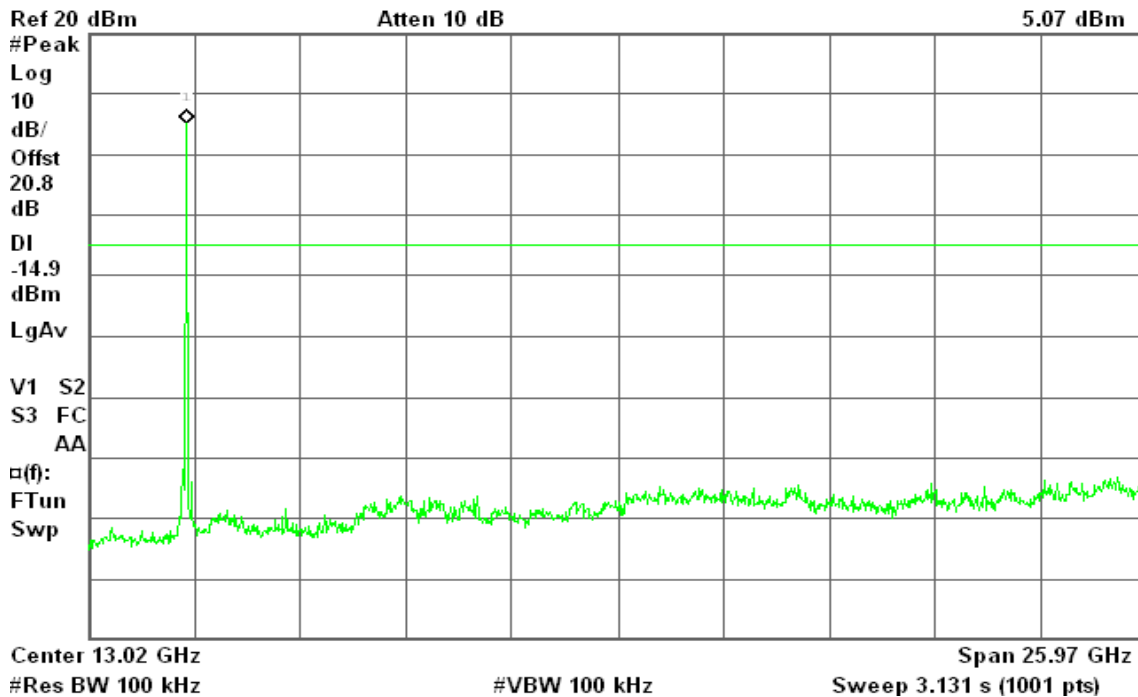



IEEE 802.11b / CH High

Agilent 11:14:00 Sep 29, 2009

R T

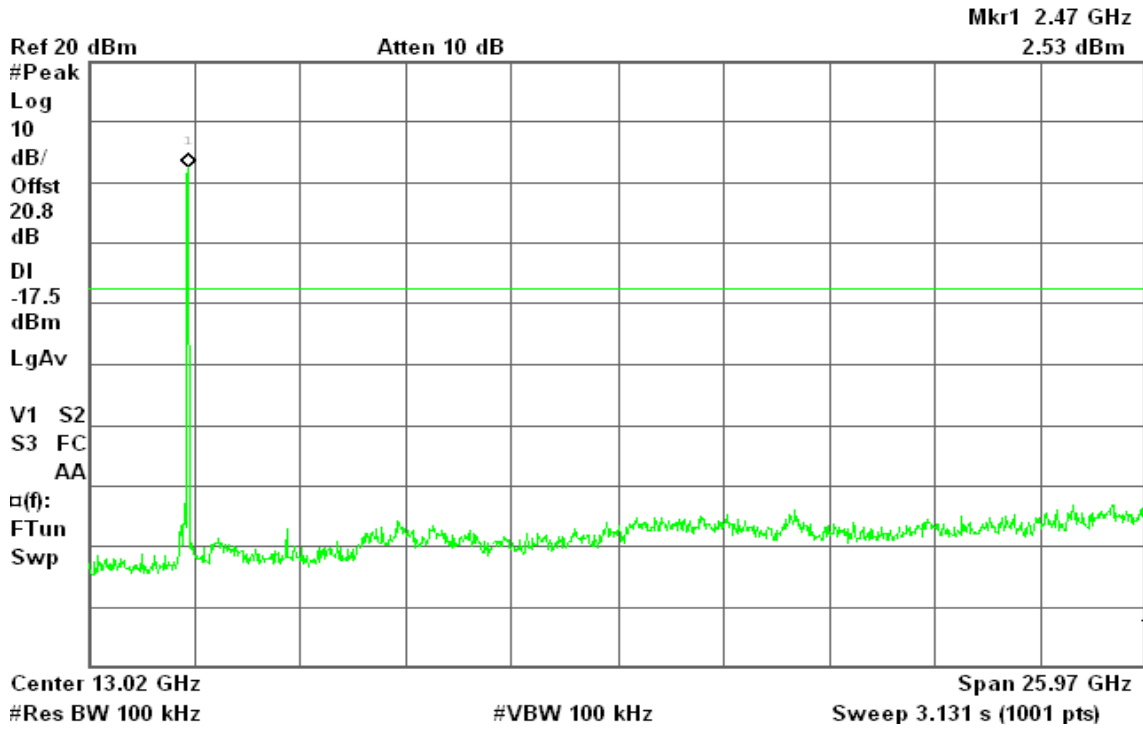

IEEE 802.11g / CH Low

Agilent 11:23:45 Sep 29, 2009

R T

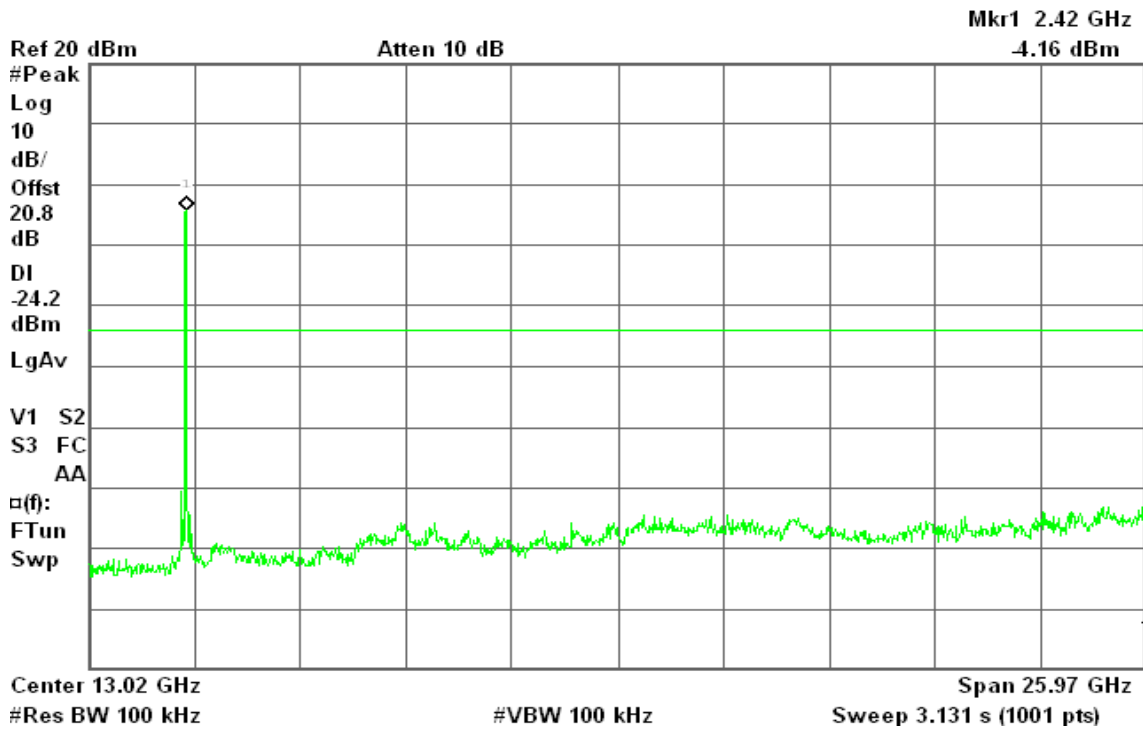



IEEE 802.11g / CH Mid

Agilent 11:28:51 Sep 29, 2009

R T

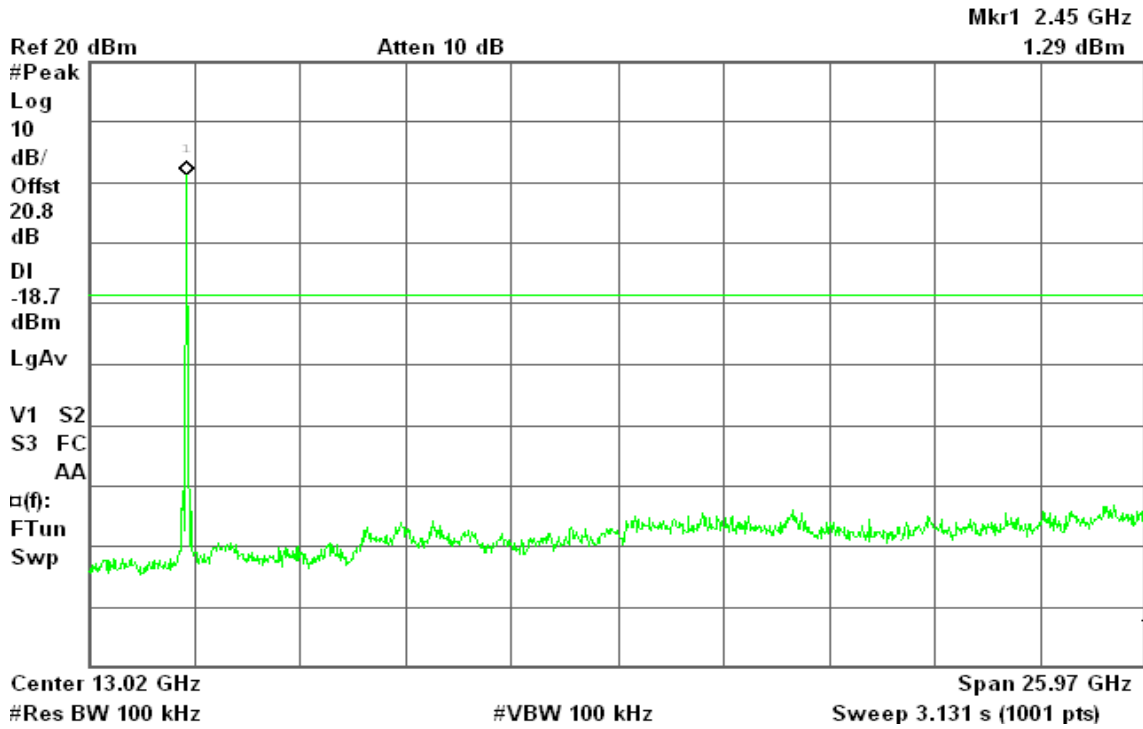

IEEE 802.11g / CH High

Agilent 11:33:51 Sep 29, 2009

R T

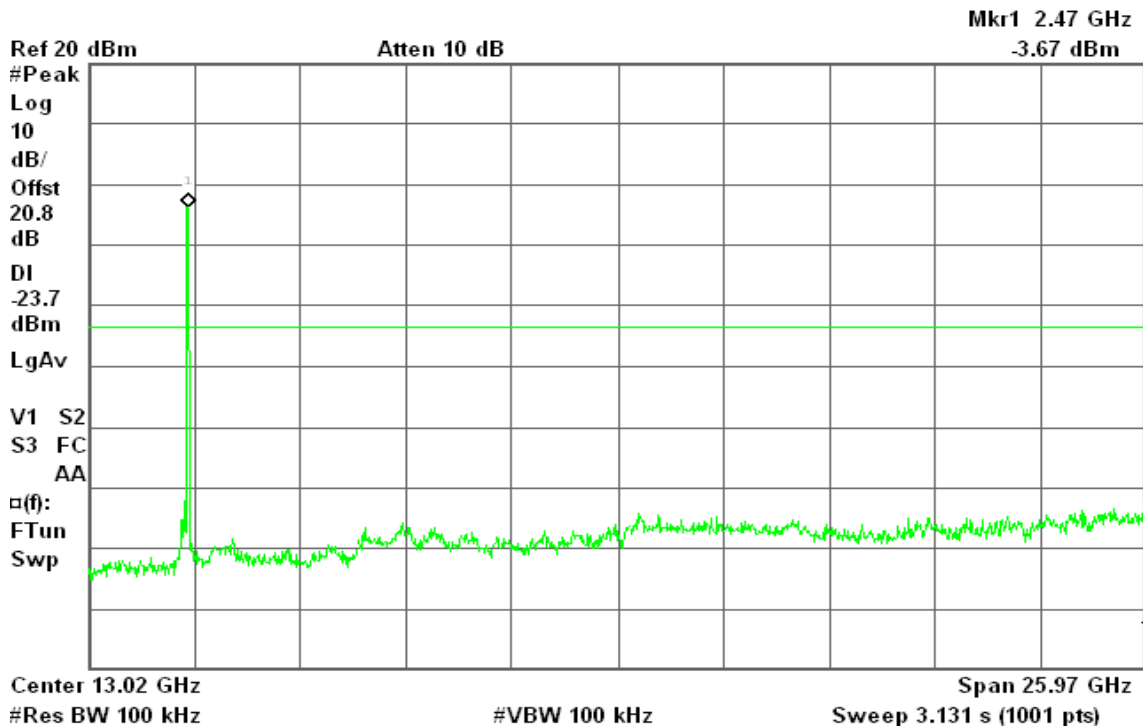



IEEE 802.11a / CH Low

Agilent 13:07:03 Sep 29, 2009

R L

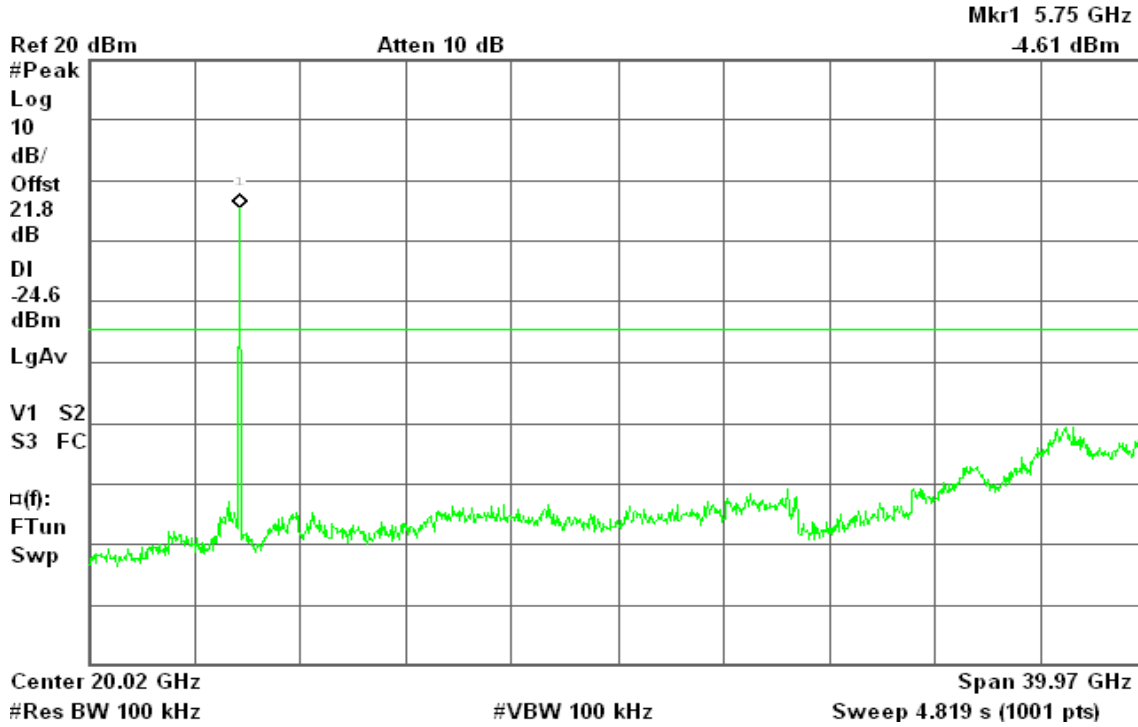

IEEE 802.11a / CH Mid

Agilent 13:12:16 Sep 29, 2009

R T

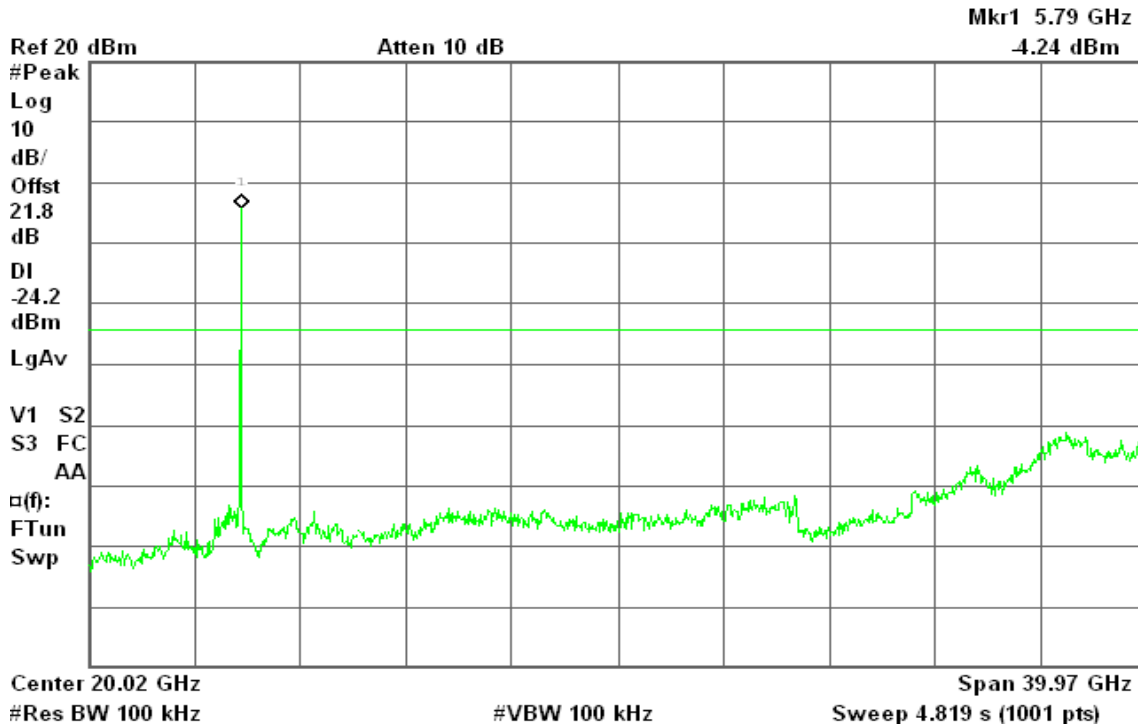



IEEE 802.11a / CH High

Agilent 13:20:31 Sep 29, 2009

R T

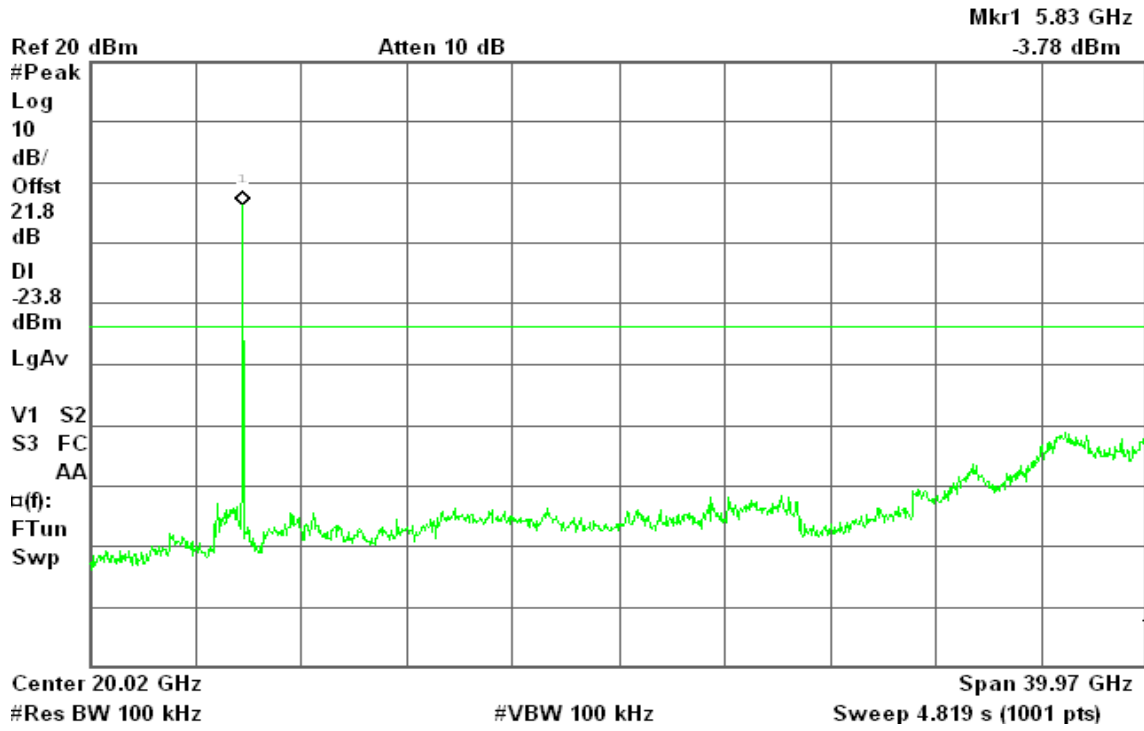



7.6.2 Radiated Emissions

LIMIT

1. Except as provided elsewhere in this Subpart, the emissions from an intentional radiator shall not exceed the field strength levels specified in the following table:

Frequency (MHz)	Field Strength ($\mu\text{V/m}$)	Measurement Distance (m)
30-88	100*	3
88-216	150*	3
216-960	200*	3
Above 960	500	3

Remark: Except as provided in paragraph (g), fundamental emissions from intentional radiators operating under this Section shall not be located in the frequency bands 54-72 MHz, 76-88 MHz, 174-216 MHz or 470-806 MHz. However, operation within these frequency bands is permitted under other sections of this Part, e.g., Sections 15.231 and 15.241.

2. In the above emission table, the tighter limit applies at the band edges.

Frequency (MHz)	Field Strength ($\mu\text{V/m}$ at 3-meter)	Field Strength (dB $\mu\text{V/m}$ at 3-meter)
30-88	100	40
88-216	150	43.5
216-960	200	46
Above 960	500	54

Test Configuration

Below 1 GHz

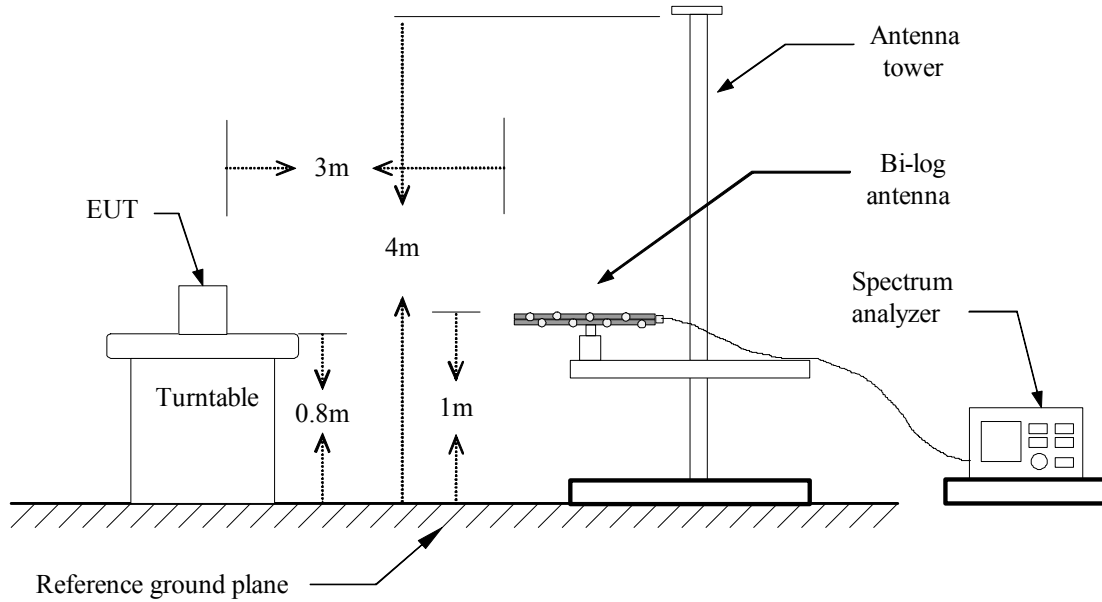

Above 1 GHz

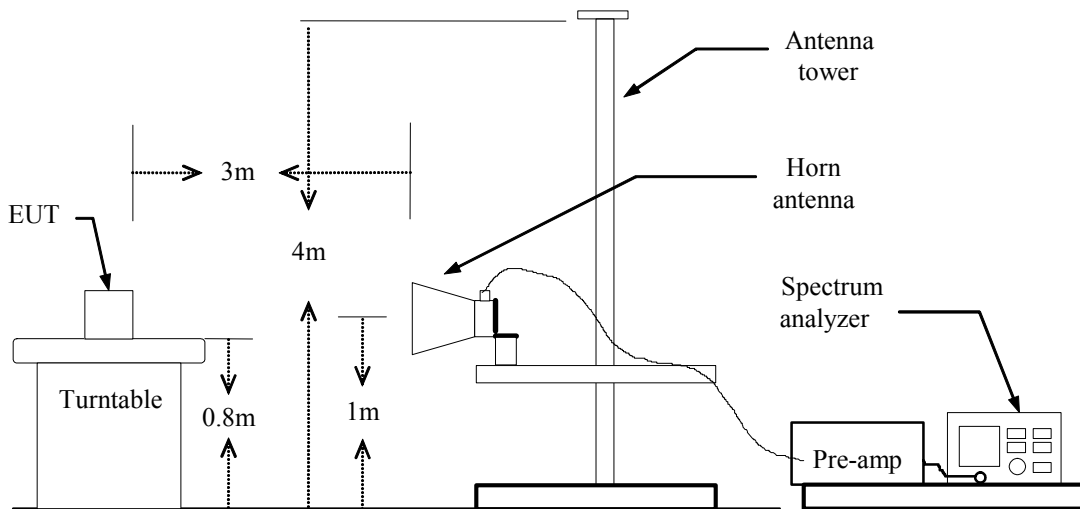



TEST PROCEDURE

1. The EUT is placed on a turntable, which is 0.8m above ground plane.
2. The turntable shall be rotated for 360 degrees to determine the position of maximum emission level.
3. EUT is set 3m away from the receiving antenna, which is varied from 1m to 4m to find out the highest emissions.
4. Maximum procedure was performed on the six highest emissions to ensure EUT compliance.
5. And also, each emission was to be maximized by changing the polarization of receiving antenna both horizontal and vertical.
6. Set the spectrum analyzer in the following setting as:
Below 1GHz:
RBW=100kHz / VBW=300kHz / Sweep=AUTO
Above 1GHz:
(a) PEAK: RBW=VBW=1MHz / Sweep=AUTO
(b) AVERAGE: RBW=1MHz / VBW=10Hz / Sweep=AUTO
7. Repeat above procedures until the measurements for all frequencies are complete.

**Below 1 GHz****Operation Mode:** Normal Link**Test Date:** September 22, 2009**Temperature:** 23°C**Tested by:** Mimic Yang**Humidity:** 53% RH**Polarity:** Ver. / Hor.

Frequency (MHz)	Ant.Pol. (H/V)	Reading (dBuV)	Correction Factor (dB/m)	Result (dBuV/m)	Limit (dBuV/m)	Margin (dB)	Remark
78.50	V	47.57	-14.94	32.63	40.00	-7.37	Peak
157.72	V	47.50	-10.24	37.26	43.50	-6.24	QP
178.73	V	51.26	-11.28	39.97	43.50	-3.53	Peak
390.52	V	38.33	-6.59	31.74	46.00	-14.26	Peak
696.07	V	33.91	-1.34	32.57	46.00	-13.43	Peak
720.32	V	34.38	-0.97	33.41	46.00	-12.59	Peak
81.73	H	39.90	-15.07	24.82	40.00	-15.18	Peak
154.48	H	45.58	-10.13	35.44	43.50	-8.06	Peak
191.67	H	49.02	-10.30	38.72	43.50	-4.78	Peak
325.85	H	41.57	-8.04	33.53	46.00	-12.47	Peak
390.52	H	41.51	-6.59	34.92	46.00	-11.08	Peak
846.42	H	29.07	0.58	29.65	46.00	-16.35	Peak

Remark:

1. No emission found between lowest internal used/generated frequency to 30MHz (9kHz~30MHz).
2. Radiated emissions measured were made with an instrument using peak/quasi-peak detector mode.
3. Quasi-peak test would be performed if the peak result were greater than the quasi-peak limit or as required by the applicant.
4. Measurements above show only up to 6 maximum emissions noted, or would be lesser, with " N/A " remark, if no specific emissions from the EUT are recorded (ie: margin>20dB from the applicable limit) and considered that's already beyond the background noise floor.
5. Margin (dB) = Remark result (dBuV/m) – Quasi-peak limit (dBuV/m).



Above 1 GHz

Operation Mode: Tx / IEEE 802.11b mode / CH Low

Test Date: September 24, 2009

Temperature: 23°C

Tested by: Mimic Yang

Humidity: 53% RH

Polarity: Ver. / Hor.

Frequency (MHz)	Ant.Pol. (H/V)	Reading (Peak) (dBuV)	Reading (Average) (dBuV)	Correction Factor (dB/m)	Result (Peak) (dBuV/m)	Result (Average) (dBuV/m)	Limit (Peak) (dBuV/m)	Limit (Average) (dBuV/m)	Margin (dB)	Remark
1296.67	V	55.66	---	-7.41	48.25	---	74.00	54.00	-5.75	Peak
N/A										
1270.00	H	55.03	---	-7.46	47.58	---	74.00	54.00	-6.42	Peak
N/A										

Remark:

1. Measuring frequencies from 1 GHz to the 10th harmonic of highest fundamental frequency.
2. Radiated emissions measured in frequency above 1000MHz were made with an instrument using peak/average detector mode.
3. Average test would be performed if the peak result were greater than the average limit or as required by the applicant.
4. Data of measurement within this frequency range shown " --- " in the table above means the reading of emissions are attenuated more than 20dB below the permissible limits or the field strength is too small to be measured.
5. Measurements above show only up to 6 maximum emissions noted, or would be lesser, with " N/A " remark, if no specific emissions from the EUT are recorded (ie: margin>20dB from the applicable limit) and considered that's already beyond the background noise floor.
6. Margin (dB) = Remark result (dBuV/m) – Average limit (dBuV/m).



Operation Mode: Tx / IEEE 802.11b mode / CH Mid

Test Date: September 24, 2009

Temperature: 23°C

Tested by: Mimic Yang

Humidity: 53% RH

Polarity: Ver. / Hor.

Frequency (MHz)	Ant.Pol. (H/V)	Reading (Peak) (dBuV)	Reading (Average) (dBuV)	Correction Factor (dB/m)	Result (Peak) (dBuV/m)	Result (Average) (dBuV/m)	Limit (Peak) (dBuV/m)	Limit (Average) (dBuV/m)	Margin (dB)	Remark
1300.00	V	55.38	---	-7.40	47.97	---	74.00	54.00	-6.03	Peak
N/A										
1413.33	H	55.26	---	-7.19	48.07	---	74.00	54.00	-5.93	Peak
N/A										

Remark:

1. Measuring frequencies from 1 GHz to the 10th harmonic of highest fundamental frequency.
2. Radiated emissions measured in frequency above 1000MHz were made with an instrument using peak/average detector mode.
3. Average test would be performed if the peak result were greater than the average limit or as required by the applicant.
4. Data of measurement within this frequency range shown " --- " in the table above means the reading of emissions are attenuated more than 20dB below the permissible limits or the field strength is too small to be measured.
5. Measurements above show only up to 6 maximum emissions noted, or would be lesser; with " N/A " remark, if no specific emissions from the EUT are recorded (ie: margin > 20dB from the applicable limit) and considered that's already beyond the background noise floor.
6. Margin (dB) = Remark result (dBuV/m) – Average limit (dBuV/m).



Operation Mode: Tx / IEEE 802.11b mode / CH High

Test Date: September 24, 2009

Temperature: 23°C

Tested by: Mimic Yang

Humidity: 53% RH

Polarity: Ver. / Hor.

Frequency (MHz)	Ant.Pol. (H/V)	Reading (Peak) (dBuV)	Reading (Average) (dBuV)	Correction Factor (dB/m)	Result (Peak) (dBuV/m)	Result (Average) (dBuV/m)	Limit (Peak) (dBuV/m)	Limit (Average) (dBuV/m)	Margin (dB)	Remark
1573.33	V	55.97	---	-6.33	49.64	---	74.00	54.00	-4.36	Peak
N/A										
1356.67	H	55.97	---	-7.30	48.68	---	74.00	54.00	-5.32	Peak
N/A										

Remark:

1. Measuring frequencies from 1 GHz to the 10th harmonic of highest fundamental frequency.
2. Radiated emissions measured in frequency above 1000MHz were made with an instrument using peak/average detector mode.
3. Average test would be performed if the peak result were greater than the average limit or as required by the applicant.
4. Data of measurement within this frequency range shown " --- " in the table above means the reading of emissions are attenuated more than 20dB below the permissible limits or the field strength is too small to be measured.
5. Measurements above show only up to 6 maximum emissions noted, or would be lesser; with " N/A " remark, if no specific emissions from the EUT are recorded (ie: margin > 20dB from the applicable limit) and considered that's already beyond the background noise floor.
6. Margin (dB) = Remark result (dBuV/m) – Average limit (dBuV/m).



Operation Mode: Tx / IEEE 802.11g mode / CH Low

Test Date: September 24, 2009

Temperature: 23°C

Tested by: Mimic Yang

Humidity: 53% RH

Polarity: Ver. / Hor.

Frequency (MHz)	Ant.Pol. (H/V)	Reading (Peak) (dBuV)	Reading (Average) (dBuV)	Correction Factor (dB/m)	Result (Peak) (dBuV/m)	Result (Average) (dBuV/m)	Limit (Peak) (dBuV/m)	Limit (Average) (dBuV/m)	Margin (dB)	Remark
1390.00	V	56.57	---	-7.23	49.34	---	74.00	54.00	-4.66	Peak
4925.00	V	48.02	---	1.01	49.03	---	74.00	54.00	-4.97	Peak
N/A										
1333.33	H	55.66	---	-7.34	48.32	---	74.00	54.00	-5.68	Peak
4841.67	H	48.66	---	1.03	49.69	---	74.00	54.00	-4.31	Peak
N/A										

Remark:

1. Measuring frequencies from 1 GHz to the 10th harmonic of highest fundamental frequency.
2. Radiated emissions measured in frequency above 1000MHz were made with an instrument using peak/average detector mode.
3. Average test would be performed if the peak result were greater than the average limit or as required by the applicant.
4. Data of measurement within this frequency range shown " --- " in the table above means the reading of emissions are attenuated more than 20dB below the permissible limits or the field strength is too small to be measured.
5. Measurements above show only up to 6 maximum emissions noted, or would be lesser; with " N/A " remark, if no specific emissions from the EUT are recorded (ie: margin > 20dB from the applicable limit) and considered that's already beyond the background noise floor.
6. Margin (dB) = Remark result (dBuV/m) – Average limit (dBuV/m).



Operation Mode: Tx / IEEE 802.11g mode / CH Mid

Test Date: September 24, 2009

Temperature: 23°C

Tested by: Mimic Yang

Humidity: 53% RH

Polarity: Ver. / Hor.

Frequency (MHz)	Ant.Pol. (H/V)	Reading (Peak) (dBuV)	Reading (Average) (dBuV)	Correction Factor (dB/m)	Result (Peak) (dBuV/m)	Result (Average) (dBuV/m)	Limit (Peak) (dBuV/m)	Limit (Average) (dBuV/m)	Margin (dB)	Remark
1400.00	V	55.65	---	-7.22	48.44	---	74.00	54.00	-5.56	Peak
4883.33	V	47.92	---	1.02	48.94	---	74.00	54.00	-5.06	Peak
N/A										
1386.67	H	55.53	---	-7.24	48.29	---	74.00	54.00	-5.71	Peak
4875.00	H	48.55	---	1.02	49.57	---	74.00	54.00	-4.43	Peak
N/A										

Remark:

1. Measuring frequencies from 1 GHz to the 10th harmonic of highest fundamental frequency.
2. Radiated emissions measured in frequency above 1000MHz were made with an instrument using peak/average detector mode.
3. Average test would be performed if the peak result were greater than the average limit or as required by the applicant.
4. Data of measurement within this frequency range shown " --- " in the table above means the reading of emissions are attenuated more than 20dB below the permissible limits or the field strength is too small to be measured.
5. Measurements above show only up to 6 maximum emissions noted, or would be lesser; with " N/A " remark, if no specific emissions from the EUT are recorded (ie: margin>20dB from the applicable limit) and considered that's already beyond the background noise floor.
6. Margin (dB) = Remark result (dBuV/m) – Average limit (dBuV/m).



Operation Mode: Tx / IEEE 802.11g mode / CH High

Test Date: September 24, 2009

Temperature: 23°C

Tested by: Mimic Yang

Humidity: 53% RH

Polarity: Ver. / Hor.

Frequency (MHz)	Ant.Pol. (H/V)	Reading (Peak) (dBuV)	Reading (Average) (dBuV)	Correction Factor (dB/m)	Result (Peak) (dBuV/m)	Result (Average) (dBuV/m)	Limit (Peak) (dBuV/m)	Limit (Average) (dBuV/m)	Margin (dB)	Remark
1330.00	V	55.71	---	-7.35	48.36	---	74.00	54.00	-5.64	Peak
4891.67	V	49.03	---	1.02	50.05	---	74.00	54.00	-3.95	Peak
N/A										
1303.33	H	55.83	---	-7.40	48.44	---	74.00	54.00	-5.56	Peak
4925.00	H	48.81	---	1.01	49.82	---	74.00	54.00	-4.18	Peak
N/A										

Remark:

1. Measuring frequencies from 1 GHz to the 10th harmonic of highest fundamental frequency.
2. Radiated emissions measured in frequency above 1000MHz were made with an instrument using peak/average detector mode.
3. Average test would be performed if the peak result were greater than the average limit or as required by the applicant.
4. Data of measurement within this frequency range shown " --- " in the table above means the reading of emissions are attenuated more than 20dB below the permissible limits or the field strength is too small to be measured.
5. Measurements above show only up to 6 maximum emissions noted, or would be lesser; with " N/A " remark, if no specific emissions from the EUT are recorded (ie: margin>20dB from the applicable limit) and considered that's already beyond the background noise floor.
6. Margin (dB) = Remark result (dBuV/m) – Average limit (dBuV/m).



Operation Mode: Tx / IEEE 802.11a mode / CH Low

Test Date: September 25, 2009

Temperature: 23°C

Tested by: Mimic Yang

Humidity: 53% RH

Polarity: Ver. / Hor.

Frequency (MHz)	Ant.Pol. (H/V)	Reading (Peak) (dBuV)	Reading (Average) (dBuV)	Correction Factor (dB/m)	Result (Peak) (dBuV/m)	Result (Average) (dBuV/m)	Limit (Peak) (dBuV/m)	Limit (Average) (dBuV/m)	Margin (dB)	Remark
1813.33	V	49.17	---	-4.03	45.14	---	74.00	54.00	-8.86	Peak
N/A										
1770.00	H	49.20	---	-4.45	44.75	---	74.00	54.00	-9.25	Peak
N/A										

Remark:

1. Measuring frequencies from 1 GHz to the 10th harmonic of highest fundamental frequency.
2. Radiated emissions measured in frequency above 1000MHz were made with an instrument using peak/average detector mode.
3. Average test would be performed if the peak result were greater than the average limit or as required by the applicant.
4. Data of measurement within this frequency range shown " --- " in the table above means the reading of emissions are attenuated more than 20dB below the permissible limits or the field strength is too small to be measured.
5. Measurements above show only up to 6 maximum emissions noted, or would be lesser; with " N/A " remark, if no specific emissions from the EUT are recorded (ie: margin > 20dB from the applicable limit) and considered that's already beyond the background noise floor.
6. Margin (dB) = Remark result (dBuV/m) – Average limit (dBuV/m).



Operation Mode: Tx / IEEE 802.11a mode / CH Mid

Test Date: September 25, 2009

Temperature: 23°C

Tested by: Mimic Yang

Humidity: 53% RH

Polarity: Ver. / Hor.

Frequency (MHz)	Ant.Pol. (H/V)	Reading (Peak) (dBuV)	Reading (Average) (dBuV)	Correction Factor (dB/m)	Result (Peak) (dBuV/m)	Result (Average) (dBuV/m)	Limit (Peak) (dBuV/m)	Limit (Average) (dBuV/m)	Margin (dB)	Remark
1750.00	V	49.55	---	-4.64	44.91	---	74.00	54.00	-9.09	Peak
N/A										
1760.00	H	48.84	---	-4.54	44.30	---	74.00	54.00	-9.70	Peak
N/A										

Remark:

1. Measuring frequencies from 1 GHz to the 10th harmonic of highest fundamental frequency.
2. Radiated emissions measured in frequency above 1000MHz were made with an instrument using peak/average detector mode.
3. Average test would be performed if the peak result were greater than the average limit or as required by the applicant.
4. Data of measurement within this frequency range shown " --- " in the table above means the reading of emissions are attenuated more than 20dB below the permissible limits or the field strength is too small to be measured.
5. Measurements above show only up to 6 maximum emissions noted, or would be lesser; with " N/A " remark, if no specific emissions from the EUT are recorded (ie: margin > 20dB from the applicable limit) and considered that's already beyond the background noise floor.
6. Margin (dB) = Remark result (dBuV/m) – Average limit (dBuV/m).



Operation Mode: Tx / IEEE 802.11a mode / CH High

Test Date: September 25, 2009

Temperature: 23°C

Tested by: Mimic Yang

Humidity: 53% RH

Polarity: Ver. / Hor.

Frequency (MHz)	Ant.Pol. (H/V)	Reading (Peak) (dBuV)	Reading (Average) (dBuV)	Correction Factor (dB/m)	Result (Peak) (dBuV/m)	Result (Average) (dBuV/m)	Limit (Peak) (dBuV/m)	Limit (Average) (dBuV/m)	Margin (dB)	Remark
1746.67	V	49.14	---	-4.67	44.47	---	74.00	54.00	-9.53	Peak
N/A										
1793.33	H	49.81	---	-4.23	45.59	---	74.00	54.00	-8.41	Peak
N/A										

Remark:

1. Measuring frequencies from 1 GHz to the 10th harmonic of highest fundamental frequency.
2. Radiated emissions measured in frequency above 1000MHz were made with an instrument using peak/average detector mode.
3. Average test would be performed if the peak result were greater than the average limit or as required by the applicant.
4. Data of measurement within this frequency range shown " --- " in the table above means the reading of emissions are attenuated more than 20dB below the permissible limits or the field strength is too small to be measured.
5. Measurements above show only up to 6 maximum emissions noted, or would be lesser; with " N/A " remark, if no specific emissions from the EUT are recorded (ie: margin > 20dB from the applicable limit) and considered that's already beyond the background noise floor.
6. Margin (dB) = Remark result (dBuV/m) – Average limit (dBuV/m).



7.7 POWERLINE CONDUCTED EMISSIONS

LIMIT

According to §15.207(a), except as shown in paragraphs (b) and (c) of this section, for an intentional radiator that is designed to be connected to the public utility (AC) power line, the radio frequency voltage that is conducted back onto the AC power line on any frequency or frequencies within the band 150 kHz to 30 MHz shall not exceed the limits in the following table, as measured using a 50 μ H/50 ohms line impedance stabilization network (LISN). Compliance with the provisions of this paragraph shall be based on the measurement of the radio frequency voltage between each power line and ground at the power terminal. The lower limit applies at the boundary between the frequency ranges.

Frequency Range (MHz)	Limits (dB μ V)	
	Quasi-peak	Average
0.15 to 0.50	66 to 56*	56 to 46*
0.50 to 5	56	46
5 to 30	60	50

* Decreases with the logarithm of the frequency.

Test Configuration

See test photographs attached in Appendix 1 for the actual connections between EUT and support equipment.

TEST PROCEDURE

1. The EUT was placed on a table, which is 0.8m above ground plane.
2. Maximum procedure was performed on the six highest emissions to ensure EUT compliance.
3. Repeat above procedures until all frequency measured were complete.



TEST RESULTS

The initial step in collecting conducted data is a spectrum analyzer peak scan of the measurement range. Significant peaks are then marked as shown on the following data page, and these signals are then quasi-peaked.

Test Data

Operation Mode: Normal Link **Test Date:** October 4, 2009
Temperature: 22°C **Tested by:** Eddy Chung
Humidity: 45% RH

Freq. (MHz)	QP Reading (dBuV)	AV Reading (dBuV)	Corr. factor (dB)	QP Result (dBuV)	AV Result (dBuV)	QP Limit (dBuV)	AV Limit (dBuV)	QP Margin (dB)	AV Margin (dB)	Note
0.1900	42.90	42.10	0.10	43.00	42.20	64.04	54.04	-21.04	-11.84	L1
0.3250	40.42	40.02	0.08	40.50	40.10	59.58	49.58	-19.08	-9.48	L1
0.3900	37.33	30.83	0.07	37.40	30.90	58.06	48.06	-20.66	-17.16	L1
0.4500	43.43	42.93	0.07	43.50	43.00	56.88	46.88	-13.38	-3.88	L1
0.5150	40.44	40.14	0.06	40.50	40.20	56.00	46.00	-15.50	-5.80	L1
1.6800	36.94	29.34	0.06	37.00	29.40	56.00	46.00	-19.00	-16.60	L1
0.1900	43.19	43.09	0.11	43.30	43.20	64.04	54.04	-20.74	-10.84	L2
0.3250	40.71	40.21	0.09	40.80	40.30	59.58	49.58	-18.78	-9.28	L2
0.3900	38.91	33.81	0.09	39.00	33.90	58.06	48.06	-19.06	-14.16	L2
0.4500	44.02	43.12	0.08	44.10	43.20	56.88	46.88	-12.78	-3.68	L2
0.5150	40.32	39.92	0.08	40.40	40.00	56.00	46.00	-15.60	-6.00	L2
1.6850	35.72	27.92	0.08	35.80	28.00	56.00	46.00	-20.20	-18.00	L2

Remark:

1. Measuring frequencies from 0.15 MHz to 30MHz.
2. The emissions measured in frequency range from 0.15 MHz to 30MHz were made with an instrument using Quasi-peak detector and average detector.
3. The IF bandwidth of SPA between 0.15MHz to 30MHz was 10kHz; the IF bandwidth of Test Receiver between 0.15MHz to 30MHz was 9kHz.
4. L1 = Line One (Live Line) / L2 = Line Two (Neutral Line)



Test Plots

Conducted emissions (Line 1)

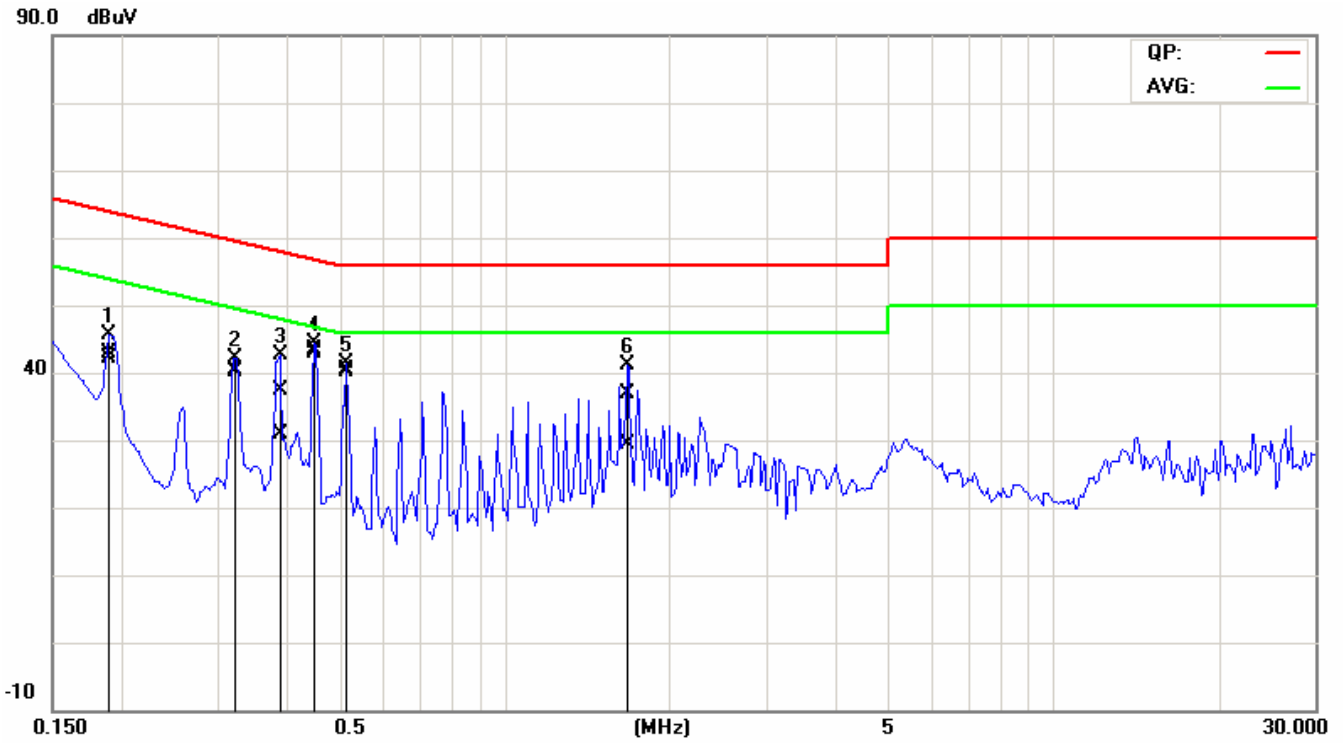

Conducted emissions (Line 2)

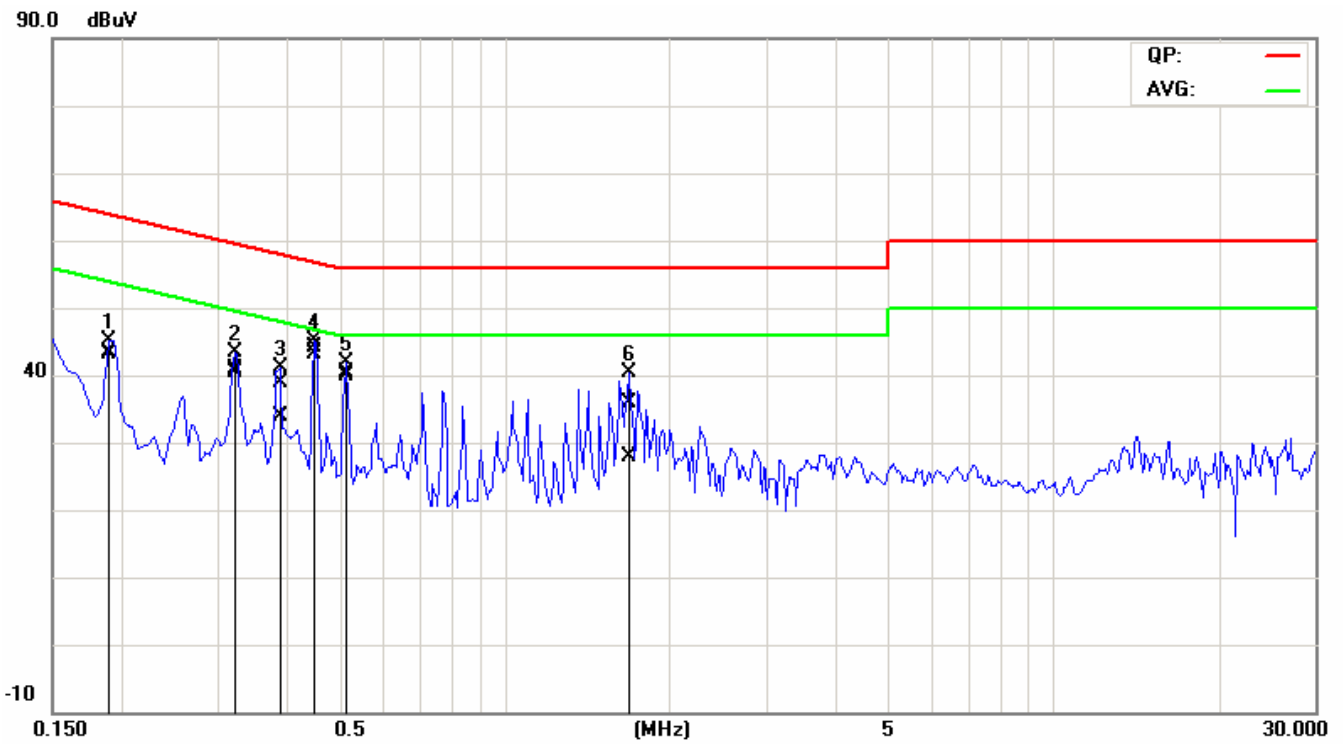



APPENDIX I RADIO FREQUENCY EXPOSURE

LIMIT

According to §15.247(i), systems operating under the provisions of this section shall be operated in a manner that ensures that the public is not exposed to radio frequency energy levels in excess of the Commission's guidelines. See § 1.1307(b)(1) of this chapter.

EUT Specification

EUT	TABLET COMPUTER
Frequency band (Operating)	<input checked="" type="checkbox"/> WLAN: 2.412GHz ~ 2.462GHz <input type="checkbox"/> WLAN: 5.745GHz ~ 5.825GHz <input type="checkbox"/> Others: Bluetooth: 2.402GHz ~ 2.480GHz
Device category	<input checked="" type="checkbox"/> Portable (<20cm separation) <input type="checkbox"/> Mobile (>20cm separation) <input type="checkbox"/> Others
Exposure classification	<input type="checkbox"/> Occupational/Controlled exposure (S = 5mW/cm2) <input checked="" type="checkbox"/> General Population/Uncontrolled exposure (S=1mW/cm2)
Antenna diversity	<input checked="" type="checkbox"/> Single antenna <input type="checkbox"/> Multiple antennas <input type="checkbox"/> Tx diversity <input type="checkbox"/> Rx diversity <input type="checkbox"/> Tx/Rx diversity
Max. output power	IEEE 802.11b mode: 19.04 dBm (80.17mW) IEEE 802.11g mode: 22.28 dBm (169.04mW)
Antenna gain (Max)	1.92 dBi (Numeric gain: 1.56)
Evaluation applied	<input type="checkbox"/> MPE Evaluation <input checked="" type="checkbox"/> SAR Evaluation* <input type="checkbox"/> N/A

Remark:

1. The maximum output power is 22.28 dBm (169.04mW) at 2437MHz (with 1.56 numeric antenna gain.)
2. DTS device is not subject to routine RF evaluation; MPE estimate is used to justify the compliance.
3. For mobile or fixed location transmitters, no SAR consideration applied. The maximum power density is 1.0 mW/cm^2 even if the calculation indicates that the power density would be larger.

TEST RESULTS

No non-compliance noted.

Remark: Please refer to the separated SAR report.



EUT	TABLET COMPUTER
Frequency band (Operating)	<input type="checkbox"/> WLAN: 2.412GHz ~ 2.462GHz <input checked="" type="checkbox"/> WLAN: 5.745GHz ~ 5.825GHz <input type="checkbox"/> Others: <u>Bluetooth: 2.402GHz ~ 2.480GHz</u>
Device category	<input checked="" type="checkbox"/> Portable (<20cm separation) <input type="checkbox"/> Mobile (>20cm separation) <input type="checkbox"/> Others
Exposure classification	<input type="checkbox"/> Occupational/Controlled exposure (S = 5mW/cm2) <input checked="" type="checkbox"/> General Population/Uncontrolled exposure (S=1mW/cm2)
Antenna diversity	<input checked="" type="checkbox"/> Single antenna <input type="checkbox"/> Multiple antennas <input type="checkbox"/> Tx diversity <input type="checkbox"/> Rx diversity <input type="checkbox"/> Tx/Rx diversity
Max. output power	IEEE 802.11a mode: 19.28 dBm (84.72mW)
Antenna gain (Max)	3.55 dBi (Numeric gain: 2.26)
Evaluation applied	<input type="checkbox"/> MPE Evaluation <input checked="" type="checkbox"/> SAR Evaluation* <input type="checkbox"/> N/A

Remark:

- The maximum output power is 19.28dBm (84.72mW) at 5745MHz (with 2.26 numeric antenna gain.)
- DTS device is not subject to routine RF evaluation; MPE estimate is used to justify the compliance.
- For mobile or fixed location transmitters, no SAR consideration applied. The maximum power density is 1.0 mW/cm^2 even if the calculation indicates that the power density would be larger.

TEST RESULTS

No non-compliance noted.

Remark: Please refer to the separated SAR report.