

FCC SAR Test Report

Product Name : Handheld Computer
Model No. : DK10

Applicant : MilDef Crete Inc.
Address : 7F, No.250, Sec.3, Pei Shen Rd., Shen Keng District,
New Taipei City Taiwan R.O.C.

Date of Receipt : 2013/06/13
Issued Date : 2013/08/12
Report No. : 136253R-HPUSP09V01
Report Version : V1.0



The test results relate only to the samples tested.

The test report shall not be reproduced except in full without the written approval of Quietek Corporation.

Test Report Certification

Issued Date: 2013/08/12

Report No.: 136253R-HPUSP09V01



Product Name : Handheld Computer
Applicant : MilDef Crete Inc.
Address : 7F, No.250, Sec.3, Pei Shen Rd., Shen Keng District, New Taipei City Taiwan R.O.C.
Manufacturer : MilDef Crete Inc.
Model No. : DK10
FCC ID : IR5DK10
Applicable Standard : FCC Oet65 Supplement C June 2001
IEEE Std. 1528-2003
47CFR § 2.1093
Measurement : KDB 865664 ,KDB 447498 , KDB 248227, KDB616217
procedures
Test Result : Max. SAR Measurement (1g)
802.11b/g(2.4GHz): **0.892** W/kg
802.11a(5 GHz): **1.323** W/kg
Application Type : Certification

The test results relate only to the samples tested.

The test report shall not be reproduced except in full without the written approval of Quietek Corporation.

Documented By :

(Adm. Specialist / April Chen)

Tested By :

(Engineer / Wen Lee)

Approved By :

(Manager / Vincent Lin)

TABLE OF CONTENTS

Description	Page
1. General Information.....	5
1.1 EUT Description	5
1.2 Antenna List.....	5
1.3 Maximum output power and tolerance allowed for production units.....	6
1.4 Test Environment.....	6
2. SAR Measurement System	7
2.1 DASY5 System Description	7
2.1.1 Applications	8
2.1.2 Area Scans.....	8
2.1.3 Zoom Scan (Cube Scan Averaging).....	8
2.1.4 Uncertainty of Inter-/Extrapolation and Averaging.....	8
2.2 DASY5 E-Field Probe	9
2.2.1 Isotropic E-Field Probe Specification	9
2.3 Boundary Detection Unit and Probe Mounting Device.....	10
2.4 DATA Acquisition Electronics (DAE) and Measurement Server	10
2.5 Robot.....	11
2.6 Light Beam Unit.....	11
2.7 Device Holder	12
2.8 SAM Twin Phantom	12
3. Tissue Simulating Liquid	13
3.1 The composition of the tissue simulating liquid	13
3.2 Tissue Calibration Result.....	13
3.3 Tissue Dielectric Parameters for Head and Body Phantoms	15
4. SAR Measurement Procedure	16
4.1 SAR System Check.....	16
4.1.1 Dipoles	16
4.1.2 System Check Result	16
4.2 SAR Measurement Procedure.....	18
5. SAR Exposure Limits	19
6. Test Equipment List.....	20
7. Measurement Uncertainty	21
8. Conducted Power Measurement	23
9. Test Result.....	24
9.1 SAR Test Results Summary.....	24
10. SAR measurement variability	26

Appendix.....27

Appendix A. SAR System Check Data

Appendix B. SAR measurement Data

Appendix C. Test Setup Photographs & EUT Photographs

Appendix D. Probe Calibration Data

Appendix E. Dipole Calibration Data

1. General Information

1.1 EUT Description

Product Name	Handheld Computer
Model No.	DK10
FCC ID	IR5DK10
TX Frequency	802.11b/g/n: 2412MHz~2462MHz 802.11a/n: 5725MHz~5825MHz
Wlan Modular	MFR: Intel, M/N: 6235ANHMW
Type of Modulation	DSSS/OFDM/BPSK/QPSK/16QAM/64QAM
Antenna Type	PIFA
Device Category	Portable
RF Exposure Environment	Uncontrolled
Max. Output Power (Conducted)	802.11b: 14.45 dBm 802.11g: 16.02 dBm 802.11a: 15.27 dBm

* Note : Per FCC KDB 447498 D01,

(i) The output power of BT is less than 10mW, so SAR not required.

(ii) BT & WLAN can't work simultaneously, thus simultaneous mode is no need.

1.2 Antenna List

No.	Manufacturer	Part No.	Peak Gain
1	MilDef Crete Inc.	DK10 Main Antenna DK10 Aux Antenna	2.15 dBi for 2.4 GHz 4.90 dBi for 5.0 GHz

1.3 Maximum output power and tolerance allowed for production units

Band	Mode	Nominal power (dBm)	Tolerance (dBm)	Upper Tolerance (dBm)
2.4G	802.11b Main	12.5	+/-1.5	14
2.4G	802.11b Aux	14	+/-1.5	15.5
2.4G	802.11g Main	9.5	+/-1.5	11
2.4G	802.11g Aux & 802.11n-20 & n-40	15	+/-1.5	16.5
5G	802.11a Main	13.5	+/-1.5	15
5G	802.11a Aux	15	+/-1.5	15.5
5G	802.11n-20	16.5	+/-1.5	18
5G	802.11n-40	15.5	+/-1.5	17

1.4 Test Environment

Ambient conditions in the laboratory:

Test Date: Jul 27, 2013

Items	Required	Actual
Temperature (°C)	18-25	22.8± 2
Humidity (%RH)	30-70	52

Test Date: Jul 28, 2013

Items	Required	Actual
Temperature (°C)	18-25	23.6± 2
Humidity (%RH)	30-70	50

Site Description:

Accredited by TAF
 Accredited Number: 0914
 Effective through: December 12, 2014

Site Name: Quietek Corporation

Site Address: No. 5-22, Rueishu Keng, Linkou Dist.,
 New Taipei City 24451,
 Taiwan. R.O.C.
 TEL: 886-2-8601-3788 / FAX: 886-2-8601-3789
 E-Mail: service@quietek.com

2. SAR Measurement System

2.1 DASY5 System Description

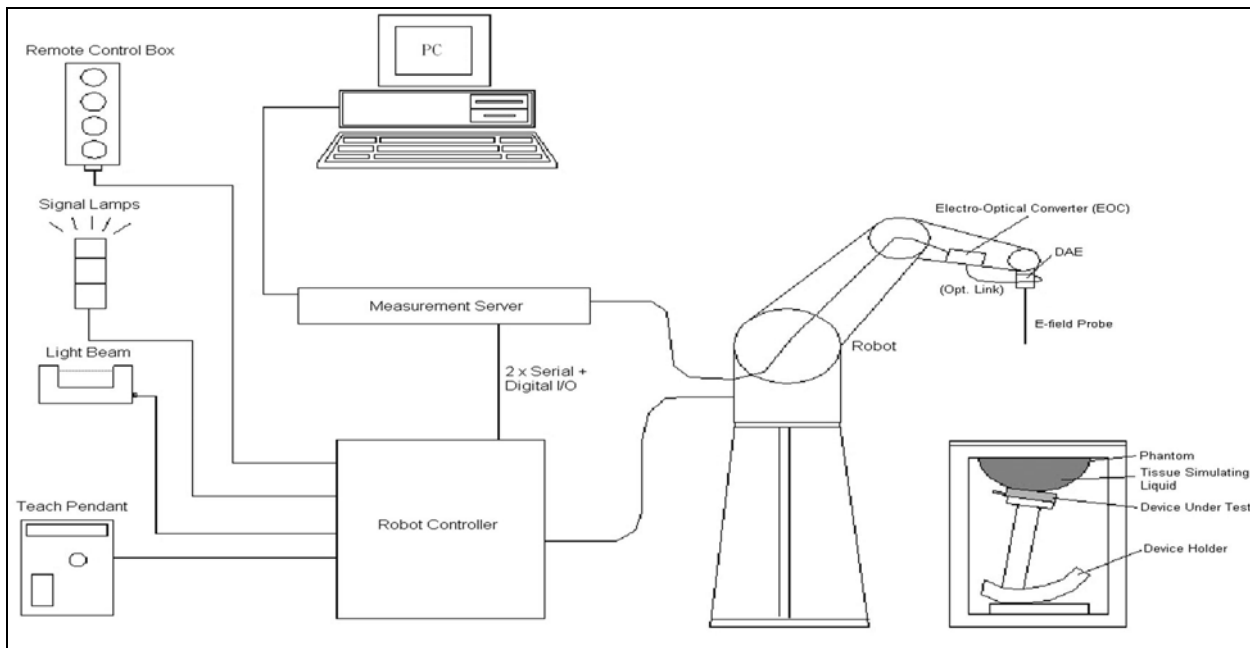

The DASY5 system for performing compliance tests consists of the following items:

- A standard high precision 6-axis robot with controller, teach pendant and software. An arm extension for accommodating the data acquisition electronics (DAE).
- A data acquisition electronics (DAE) which performs the signal amplification, signal multiplexing, AD-conversion, offset measurements, mechanical surface detection, collision detection, etc. The unit is battery powered with standard or rechargeable batteries. The signal is optically transmitted to the EOC.
- The Electro-optical converter (EOC) performs the conversion from optical to electrical signals for the digital communication to the DAE. To use optical surface detection, a special version of the EOC is required. The EOC signal is transmitted to the measurement server.
- The Light Beam used is for probe alignment. This improves the (absolute) accuracy of the probe positioning.
- A computer running WinXP and the DASY5 software.
- Remote control and teach pendant as well as additional circuitry for robot safety such as warning lamps, etc.
- The phantom, the device holder and other accessories according to the targeted measurement.

2.1.1 Applications

Predefined procedures and evaluations for automated compliance testing with all worldwide standards, e.g., IEEE 1528, OET 65, IEC 62209-1, IEC 62209-2, EN 50360, EN 50383 and others.

2.1.2 Area Scans

Area scans are defined prior to the measurement process being executed with a user defined variable spacing between each measurement point (integral) allowing low uncertainty measurements to be conducted. Scans defined for FCC applications utilize a 10mm² step integral, with 1mm interpolation used to locate the peak SAR area used for zoom scan assessments.

When an Area Scan has measured all reachable points, it computes the field maxima found in the scanned area, within a range of the global maximum. The range (in dB) is specified in the standards for compliance testing. For example, a 2 dB range is required in IEEE 1528-2003, EN 50361 and IEC 62209 standards, whereby 3 dB is a requirement when compliance is assessed in accordance with the ARIB standard (Japan).

2.1.3 Zoom Scan (Cube Scan Averaging)

Zoom Scans are used to assess the peak spatial SAR values within a cubic averaging volume containing 1 g and 10 g of simulated tissue. A density of 1000 kg/m³ is used to represent the head and body tissue density and not the phantom liquid density, in order to be consistent with the definition of the liquid dielectric properties, i.e. the side length of the 1 g cube is 10mm, with the side length of the 10 g cube 21,5mm.

The zoom scan integer steps can be user defined so as to reduce uncertainty, but normal practice for typical test applications (including FCC) utilize a physical step of 5x5x7 (8mmx8mmx5mm) providing a volume of 32mm in the X & Y axis, and 30mm in the Z axis.

2.1.4 Uncertainty of Inter-/Extrapolation and Averaging

In order to evaluate the uncertainty of the interpolation, extrapolation and averaged SAR calculation algorithms of the Postprocessor, DASY5 allows the generation of measurement grids which are artificially predefined by analytically based test functions. Therefore, the grids of area scans and zoom scans can be filled with uncertainty test data, according to the SAR benchmark functions of IEEE 1528. The three analytical functions shown in equations as below are used to describe the possible range of the expected SAR distributions for the tested handsets. The field gradients are covered by the spatially flat

distribution f1, the spatially steep distribution f3 and f2 accounts for H-field cancellation on the phantom/tissue surface.

$$f_1(x, y, z) = Ae^{-\frac{z}{2a}} \cos^2 \left(\frac{\pi \sqrt{x'^2 + y'^2}}{2 \cdot 5a} \right)$$

$$f_2(x, y, z) = Ae^{-\frac{z}{a}} \frac{a^2}{a^2 + x'^2} \left(3 - e^{-\frac{2z}{a}} \right) \cos^2 \left(\frac{\pi y'}{2 \cdot 3a} \right)$$

$$f_3(x, y, z) = A \frac{a^2}{\frac{a^2}{4} + x'^2 + y'^2} \left(e^{-\frac{2z}{a}} + \frac{a^2}{2(a + 2z)^2} \right)$$

2.2 DASY5 E-Field Probe

The SAR measurement is conducted with the dosimetric probe manufactured by SPEAG.

The probe is specially designed and calibrated for use in liquid with high permittivity. The dosimetric probe has special calibration in liquid at different frequency.

SPEAG conducts the probe calibration in compliance with international and national standards (e.g. IEEE 1528, EN 62209-1, IEC 62209, etc.) under ISO 17025. The calibration data are in Appendix D.

2.2.1 Isotropic E-Field Probe Specification

Model	Ex3DV4	
Construction	Symmetrical design with triangular core Built-in shielding against static charges PEEK enclosure material (resistant to organic solvents, e.g., DGBE)	
Frequency	10 MHz to 6 GHz Linearity: ± 0.2 dB (30 MHz to 6 GHz)	
Directivity	± 0.3 dB in HSL (rotation around probe axis) ± 0.5 dB in tissue material (rotation normal to probe axis)	
Dynamic Range	10 µW/g to 100 mW/g Linearity: ± 0.2 dB (noise: typically < 1 µW/g)	
Dimensions	Overall length: 330 mm (Tip: 20 mm) Tip diameter: 2.5 mm (Body: 12 mm) Typical distance from probe tip to dipole centers: 1 mm	
Application	High precision dosimetric measurements in any exposure scenario (e.g., very strong gradient fields). Only probe which enables compliance testing for frequencies up to 6 GHz with precision of better 30%.	

2.3 Boundary Detection Unit and Probe Mounting Device

The DASY probes use a precise connector and an additional holder for the probe, consisting of a plastic tube and a flexible silicon ring to center the probe. The connector at the DAE is flexibly mounted and held in the default position with magnets and springs. Two switching systems in the connector mount detect frontal and lateral probe collisions and trigger the necessary software response.



2.4 DATA Acquisition Electronics (DAE) and Measurement Server

The data acquisition electronics (DAE) consists of a highly sensitive electrometer-grade preamplifier with auto-zeroing, a channel and gain-switching multiplexer, a fast 16 bit AD-converter and a command decoder and control logic unit.

Transmission to the measurement server is accomplished through an optical downlink for data and status information as well as an optical uplink for commands and the clock.

The input impedance of the DAE4 is 200M Ohm; the inputs are symmetrical and floating. Common mode rejection is above 80dB.



The DASY5 measurement server is based on a PC/104 CPU board with a 400MHz intel ULV Celeron, 128MB chipdisk and 128MB RAM. The necessary circuits for communication with the DAE electronics box, as well as the 16 bit AD converter system for optical detection and digital I/O interface are contained on the DASY5 I/O board, which is directly connected to the PC/104 bus of the CPU board.



2.5 Robot

The DASY5 system uses the high precision robots TX90 XL type out of the newer series from Stäubli SA (France). For the 6-axis controller DASY5 system, the CS8C robot controller version from Stäubli is used.

The XL robot series have many features that are important for our application:

- High precision (repeatability 0.02 mm)
- High reliability (industrial design)
- Jerk-free straight movements
- Low ELF interference (the closed metallic construction shields against motor control fields)
- 6-axis controller



2.6 Light Beam Unit

The light beam switch allows automatic "tooling" of the probe. During the process, the actual position of the probe tip with respect to the robot arm is measured, as well as the probe length and the horizontal probe offset. The software then corrects all movements, such that the robot coordinates are valid for the probe tip.

The repeatability of this process is better than 0.1 mm. If a position has been taught with an aligned probe, the same position will be reached with another aligned probe within 0.1 mm, even if the other probe has different dimensions. During probe rotations, the probe tip will keep its actual position.



2.7 Device Holder

The DASY5 device holder is designed to cope with different positions given in the standard. It has two scales for the device rotation (with respect to the body axis) and the device inclination (with respect to the line between the ear reference points). The rotation center for both scales is the ear reference point (EPR).

Thus the device needs no repositioning when changing the angles.

The DASY5 device holder has been made out of low-loss POM material having the following dielectric parameters: relative permittivity $\epsilon_r = 3$ and loss tangent $\delta = 0.02$. The amount of dielectric material has been reduced in the closest vicinity of the device, since measurements have suggested that the influence of the clamp on the test results could thus be lowered.



2.8 SAM Twin Phantom

The SAM twin phantom is a fiberglass shell phantom with 2mm shell thickness (except the ear region where shell thickness increases to 6mm). It has three measurement areas:

- Left head
- Right head
- Flat phantom



The bottom plate contains three pair of bolts for locking the device holder. The device holder positions are adjusted to the standard measurement positions in the three sections. A white cover is provided to tap the phantom during off-periods to prevent water evaporation and changes in the liquid parameters. On the phantom top, three reference markers are provided to identify the phantom position with respect to the robot.

3. Tissue Simulating Liquid

3.1 The composition of the tissue simulating liquid

INGREDIENT (% Weight)	2450MHz Head	2450MHz Body	5200MHz Body	5800MHz Body
Water	46.7	73.2	76	75.68
Salt	0.00	0.04	0.00	0.43
Sugar	0.00	0.00	0.00	0.00
HEC	0.00	0.00	0.00	0.00
Preventol	0.00	0.00	0.00	0.00
DGBE	53.3	26.7	4.44	4.42
Triton X-100	0.00	0.00	19.56	19.47

3.2 Tissue Calibration Result

The dielectric parameters of the liquids were verified prior to the SAR evaluation using APREL Dielectric Probe Kit and Anritsu MS4623B Vector Network Analyzer.

Body Tissue Simulate Measurement				
Frequency [MHz]	Description	Dielectric Parameters		Tissue Temp. [°C]
		ϵ_r	σ [s/m]	
2450 MHz	Reference result ± 5% window	52.7 50.065 to 55.335	1.95 1.8525 to 2.0475	N/A
	28-Jul-13	51.42	1.94	22.4
2412 MHz	Low channel	52.03	1.91	22.4
2437 MHz	Mid channel	51.46	1.93	22.4
2462 MHz	High channel	51.33	1.96	22.4

Body Tissue Simulant Measurement				
Frequency [MHz]	Description	Dielectric Parameters		Tissue Temp. [°C]
		ϵ_r	σ [s/m]	
5800MHz	Reference result ± 5% window	48.2 45.79 to 50.61	6 5.7 to 6.3	N/A
	27-Jul-13	46.11	6.26	21.1
5745 MHz	Low channel	46.65	6.21	21.1
5785 MHz	Mid channel	46.24	6.24	21.1
5825 MHz	High channel	46.03	6.28	21.1

3.3 Tissue Dielectric Parameters for Head and Body Phantoms

The head tissue dielectric parameters recommended by the IEEE SCC-34/SC-2 in P1528 have been incorporated in the following table. These head parameters are derived from planar layer models simulating the highest expected SAR for the dielectric properties and tissue thickness variations in a human head. Other head and body tissue parameters that have not been specified in P1528 are derived from the tissue dielectric parameters computed from the 4-Cole-Cole equations described in Reference [12] and extrapolated according to the head parameters specified in P1528.

Target Frequency (MHz)	Head		Body	
	ϵ_r	σ (S/m)	ϵ_r	σ (S/m)
150	52.3	0.76	61.9	0.80
300	45.3	0.87	58.2	0.92
450	43.5	0.87	56.7	0.94
835	41.5	0.90	55.2	0.97
900	41.5	0.97	55.0	1.05
915	41.5	0.98	55.0	1.06
1450	40.5	1.20	54.0	1.30
1610	40.3	1.29	53.8	1.40
1800 – 2000	40.0	1.40	53.3	1.52
2450	39.2	1.80	52.7	1.95
3000	38.5	2.40	52.0	2.73
5800	35.3	5.27	48.2	6.00

(ϵ_r = relative permittivity, σ = conductivity and $\rho = 1000 \text{ kg/m}^3$)

4. SAR Measurement Procedure

4.1 SAR System Check

4.1.1 Dipoles

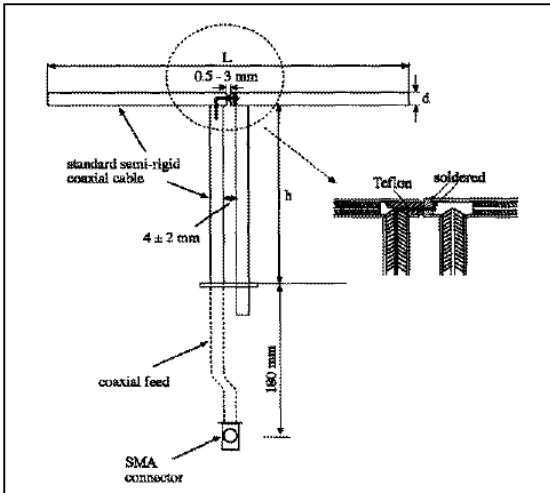

The dipoles used is based on the IEEE-1528 standard, and is complied with mechanical and electrical specifications in line with the requirements of both IEEE and FCC Supplement C. the table below provides details for the mechanical and electrical specifications for the dipoles.

Frequency	L (mm)	h (mm)	d (mm)
2450MHz	53.5	30.4	3.6
5200M~5800MHz	20.6	45.4	3.6

4.1.2 System Check Result

System Performance Check at 2450MHz				
Dipole Kit: ALS-D-2450				
Frequency [MHz]	Description	SAR [w/kg] 1g	SAR [w/kg] 10g	Tissue Temp. [°C]
2450 MHz	Reference result ± 10% window	54 48.6 to 59.40	24.96 22.46 to 27.46	N/A
	28-Jul-13	58.4	26.68	22.4

Note: (1) The power level is used 250mW
 (2) All SAR values are normalized to 1W forward power.
 (3) The reference result is from Appendix E.

System Performance Check at 5800MHz				
Dipole Kit: D5GHzV2				
Frequency [MHz]	Description	SAR [w/kg] 1g	SAR [w/kg] 10g	Tissue Temp. [°C]
5800 MHz	Reference result ± 10% window	76.7 69.03 to 84.37	21.2 19.08 to 23.32	N/A
	27-Jul-13	75.7	20.2	21.1
Note: (1) The power level is used 100mW (2) All SAR values are normalized to 1W forward power. (3) The reference result is from Appendix E.				

4.2 SAR Measurement Procedure

The Dasy5 calculates SAR using the following equation,

$$SAR = \frac{\sigma |E|^2}{\rho}$$

σ : represents the simulated tissue conductivity

ρ : represents the tissue density

The EUT is set to transmit at the required power in line with product specification, at each frequency relating to the LOW, MID, and HIGH channel settings.

Pre-scans are made on the device to establish the location for the transmitting antenna, using a large area scan in either air or tissue simulation fluid.

The EUT is placed against the Universal Phantom where the maximum area scan dimensions are larger than the physical size of the resonating antenna. When the scan size is not large enough to cover the peak SAR distribution, it is modified by either extending the area scan size in both the X and Y directions, or the device is shifted within the predefined area.

The area scan is then run to establish the peak SAR location (interpolated resolution set at 1mm²)which is then used to orient the center of the zoom scan. The zoom scan is then executed and the 1g and 10g averages are derived from the zoom scan volume (interpolated resolution set at 1mm³).

5. SAR Exposure Limits

SAR assessments have been made in line with the requirements of IEEE-1528, FCC Supplement C, and comply with ANSI/IEEE C95.1-1992 “Uncontrolled Environments” limits. These limits apply to a location which is deemed as “Uncontrolled Environment” which can be described as a situation where the general public may be exposed to an RF source with no prior knowledge or control over their exposure.

Limits for General Population/Uncontrolled Exposure (W/kg)

Type Exposure	Uncontrolled Environment Limit
Spatial Peak SAR (1g cube tissue for brain or body)	1.60 W/kg
Spatial Average SAR (whole body)	0.08 W/kg
Spatial Peak SAR (10g for hands, feet, ankles and wrist)	4.00 W/kg

6. Test Equipment List

Instrument	Manufacturer	Model No.	Serial No.	Last Calibration	Next Calibration
Stäubli Robot TX60L	Stäubli	TX60L	F09/5BL1A1/A06	2009/05/18	only once
Controller	Speag	CS8c	N/A	2009/05/18	only once
Aprél Reference Dipole 2450MHz	Aprél	ALS-D-2450	QTK-319	2012/11/20	2013/11/19
Speag Reference Dipole 5GHz	Speag	D5GHzV2	1023	2013/01/23	2015/01/22
SAM Twin Phantom	Speag	QD000 P40 CA	Tp 1515	N/A	N/A
Device Holder	Speag	N/A	N/A	N/A	N/A
Data Acquisition Electronic	Speag	DAE4	1207	2012/05/30	2013/05/29
E-Field Probe	Speag	EX3DV4	3661	2013/01/15	2014/01/14
SAR Software	Speag	DASY52	V52.8 (5)	N/A	N/A
Aprél Dipole Spaccer	Aprél	ALS-DS-U	QTK-295	N/A	N/A
Power Amplifier	Mini-Circuit	ZHL-42	D051404-20	N/A	N/A
Directional Coupler	Agilent	778D-012	50550	N/A	N/A
Universal Radio Communication Tester	R&S	CMU 200	104846	2012/05/14	2013/05/13
Vector Network	Anritsu	MS4623B	992801	2012/07/30	2013/07/29
Signal Generator	Anritsu	MG3694A	041902	2012/08/03	2013/08/02
Power Meter	Anritsu	ML2487A	6K00003357	2012/05/30	2013/05/29
Wide Bandwidth Sensor	Anritsu	MA2411B	0846193	2012/05/30	2013/05/29

7. Measurement Uncertainty

DASY5 Uncertainty								
Measurement uncertainty for 300 MHz to 3 GHz averaged over 1 gram / 10 gram.								
Error Description	Uncert. value	Prob. Dist.	Div.	(ci) 1g	(ci) 10g	Std. Unc. (1g)	Std. Unc. (10g)	(vi) V _{eff}
Measurement System								
Probe Calibration	±6.0%	N	1	1	1	±6.0%	±6.0%	∞
Axial Isotropy	±4.7%	R	$\sqrt{3}$	0.7	0.7	±1.9%	±1.9%	∞
Hemispherical Isotropy	±9.6%	R	$\sqrt{3}$	0.7	0.7	±3.9%	±3.9%	∞
Boundary Effects	±1.0%	R	$\sqrt{3}$	1	1	±0.6%	±0.6%	∞
Linearity	±4.7%	R	$\sqrt{3}$	1	1	±2.7%	±2.7%	∞
System Detection Limits	±1.0%	R	$\sqrt{3}$	1	1	±0.6%	±0.6%	∞
Readout Electronics	±0.3%	N	1	1	1	±0.3%	±0.3%	∞
Response Time	±0.8%	R	$\sqrt{3}$	1	1	±0.5%	±0.5%	∞
Integration Time	±2.6%	R	$\sqrt{3}$	1	1	±1.5%	±1.5%	∞
RF Ambient Noise	±3.0%	R	$\sqrt{3}$	1	1	±1.7%	±1.7%	∞
RF Ambient Reflections	±3.0%	R	$\sqrt{3}$	1	1	±1.7%	±1.7%	∞
Probe Positioner	±0.4%	R	$\sqrt{3}$	1	1	±0.2%	±0.2%	∞
Probe Positioning	±2.9%	R	$\sqrt{3}$	1	1	±1.7%	±1.7%	∞
Max. SAR Eval.	±1.0%	R	$\sqrt{3}$	1	1	±0.6%	±0.6%	∞
Test Sample Related								
Device Positioning	±2.9%	N	1	1	1	±2.9%	±2.9%	145
Device Holder	±3.6%	N	1	1	1	±3.6%	±3.6%	5
Power Drift	±5.0%	R	$\sqrt{3}$	1	1	±2.9%	±2.9%	∞
Phantom and Setup								
Phantom Uncertainty	±4.0%	R	$\sqrt{3}$	1	1	±2.3%	±2.3%	∞
Liquid Conductivity (target)	±5.0%	R	$\sqrt{3}$	0.64	0.43	±1.8%	±1.2%	∞
Liquid Conductivity (meas.)	±2.5%	N	1	0.64	0.43	±1.6%	±1.1%	∞
Liquid Permittivity (target)	±5.0%	R	$\sqrt{3}$	0.6	0.49	±1.7%	±1.4%	∞
Liquid Permittivity (meas.)	±2.5%	N	1	0.6	0.49	±1.5%	±1.2%	∞
Combined Std. Uncertainty						±11%	±10.8%	387
Expanded STD Uncertainty						±22%	±21.5%	

DASY5 Uncertainty								
Measurement uncertainty for 3GHz to 6 GHz averaged over 1 gram / 10 gram.								
Error Description	Uncert. value	Prob. Dist.	Div.	(ci) 1g	(ci) 10g	Std. Unc. (1g)	Std. Unc. (10g)	(vi) V _{eff}
Measurement System								
Probe Calibration	±6.6%	N	1	1	1	±6.6%	±6.6%	∞
Axial Isotropy	±4.7%	R	√3	0.7	0.7	±1.9%	±1.9%	∞
Hemispherical Isotropy	±9.6%	R	√3	0.7	0.7	±3.9%	±3.9%	∞
Boundary Effects	±2.0%	R	√3	1	1	±1.2%	±1.2%	∞
Linearity	±4.7%	R	√3	1	1	±2.7%	±2.7%	∞
System Detection Limits	±1.0%	R	√3	1	1	±0.6%	±0.6%	∞
Readout Electronics	±0.3%	N	1	1	1	±0.3%	±0.3%	∞
Response Time	±0.8%	R	√3	1	1	±0.5%	±0.5%	∞
Integration Time	±2.6%	R	√3	1	1	±1.5%	±1.5%	∞
RF Ambient Noise	±3.0%	R	√3	1	1	±1.7%	±1.7%	∞
RF Ambient Reflections	±3.0%	R	√3	1	1	±1.7%	±1.7%	∞
Probe Positioner	±0.8%	R	√3	1	1	±0.5%	±0.5%	∞
Probe Positioning	±9.9%	R	√3	1	1	±5.7%	±5.7%	∞
Max. SAR Eval.	±4.0%	R	√3	1	1	±2.3%	±2.3%	∞
Test Sample Related								
Device Positioning	±2.9%	N	1	1	1	±2.9%	±2.9%	145
Device Holder	±3.6%	N	1	1	1	±3.6%	±3.6%	5
Power Drift	±5.0%	R	√3	1	1	±2.9%	±2.9%	∞
Phantom and Setup								
Phantom Uncertainty	±4.0%	R	√3	1	1	±2.3%	±2.3%	∞
Liquid Conductivity (target)	±5.0%	R	√3	0.64	0.43	±1.8%	±1.2%	∞
Liquid Conductivity (meas.)	±2.5%	N	1	0.64	0.43	±1.6%	±1.1%	∞
Liquid Permittivity (target)	±5.0%	R	√3	0.6	0.49	±1.7%	±1.4%	∞
Liquid Permittivity (meas.)	±2.5%	N	1	0.6	0.49	±1.5%	±1.2%	∞
Combined Std. Uncertainty						±12.8%	±12.6%	330
Expanded STD Uncertainty						±25.6%	±25.2%	

8. Conducted Power Measurement

Mode	Frequency (MHz)	Channel	Main Peak Power(dBm)	Aux Peak Power(dBm)
802.11b	2412	1	12.72	14.45
802.11b	2437	6	12.63	14.35
802.11b	2462	11	12.53	14.19
802.11g	2412	1	9.66	16.02
802.11g	2437	6	9.65	15.95
802.11g	2462	11	9.55	15.78
802.11a	5745	149	14.61	15.27
802.11a	5785	157	14.53	15.10
802.11a	5825	165	14.60	14.97

Mode	Frequency (MHz)	Channel	Main Peak Power(dBm)	Aux Peak Power(dBm)	Main+Aux Peak Power(dBm)
802.11n-20M	2412	1	9.07	15.53	16.41
802.11n-20M	2437	6	9.21	15.44	16.37
802.11n-20M	2462	11	9.14	15.20	16.16
802.11n-20M	5745	149	14.16	14.81	17.51
802.11n-20M	5785	157	14.03	14.71	17.39
802.11n-20M	5825	165	14.31	14.70	17.52
802.11n-40M	2422	3	9.40	15.55	16.49
802.11n-40M	2437	6	9.44	15.55	16.50
802.11n-40M	2452	9	9.45	15.44	16.42
802.11n-40M	5755	151	13.40	14.12	16.79
802.11n-40M	5795	159	13.37	14.09	16.76

9. Test Result

9.1 SAR Test Results Summary

SAR MEASUREMENT								
Ambient Temperature (°C) : 23.6 ±2				Relative Humidity (%) : 50				
Liquid Temperature (°C) : 22.4 ±2				Depth of Liquid (cm) : >15				
Test Mode: 802.11b - 2450 MHz- MilDef Crete Inc. Main Antenna, P/N: DK10 Main Antenna								
Test Position Body	Antenna Position	Frequency		Conducted Power(dBm)		SAR 1g (W/kg)		Limit (W/kg)
		Channel	MHz	Measurement	Tune-up Limit	Measurement	Tune-up Scaled	
Top	Fixed	6	2437	12.63	14	0.607	0.832	1.6
Back	Fixed	6	2437	12.63	14	0.596	0.817	1.6
R-Side	Fixed	6	2437	12.63	14	0.030	0.041	1.6
Test Mode: 802.11b - 2450 MHz- MilDef Crete Inc. Aux Antenna, P/N: DK10 Aux Antenna								
Top	Fixed	6	2437	14.35	15.5	0.672	0.876	1.6
Back	Fixed	6	2437	14.35	15.5	0.590	0.769	1.6
L-Side	Fixed	6	2437	14.35	15.5	0.035	0.046	1.6
Test Mode: 802.11g - 2450 MHz- MilDef Crete Inc. Main Antenna, P/N: DK10 Main Antenna								
Top	Fixed	6	2437	9.65	11	0.632	0.862	1.6
Test Mode: 802.11g - 2450 MHz- MilDef Crete Inc. Aux Antenna, P/N: DK10 Aux Antenna								
Top	Fixed	1	2412	16.02	16.5	0.793	0.886	1.6
Top	Fixed	6	2437	15.95	16.5	0.786	0.892	1.6
Top	Fixed	11	2462	15.78	16.5	0.696	0.822	1.6
Test Mode: 802.11n (20M)- 2450 MHz- MilDef Crete Inc. Main Antenna DK10 Main Antenna								
Top	Fixed	6	2437	16.37	16.5	0.516	0.532	1.6
Test Mode: 802.11n (20M)- 2450 MHz- MilDef Crete Inc. Aux Antenna, P/N: DK10 Aux Antenna								
Top	Fixed	6	2437	16.37	16.5	0.740	0.762	1.6
Test Mode: 802.11n (40M)- 2450 MHz- MilDef Crete Inc. Main Antenna, P/N: DK10 Main Antenna								
Top	Fixed	6	2437	16.50	16.5	0.485	0.485	1.6
Test Mode: 802.11n (40M)- 2450 MHz- MilDef Crete Inc. Aux Antenna, P/N: DK10 Aux Antenna								
Top	Fixed	6	2437	16.50	16.5	0.746	0.746	1.6
Note : According KDB 447498 D01, for antenna(s) located ≥ 5 cm from other side , the SAR is not required.								

SAR MEASUREMENT								
Ambient Temperature (°C) : 22.8 ±2				Relative Humidity (%): 52				
Liquid Temperature (°C) : 21.1 ±2				Depth of Liquid (cm):>15				
Test Mode: 802.11a - 5 GHz- MilDef Crete Inc. Main Antenna, P/N: DK10 Main Antenna								
Test Position Body	Antenna Position	Frequency		Conducted Power (dBm)		SAR 1g (W/kg)		Limit (W/kg)
		Channel	MHz	Measurement	Tune-up Limit	Measurement	Tune-up Scaled	
Top	Fixed	149	5745	14.61	15	1.190	1.302	1.6
Top	Fixed	157	5785	14.53	15	1.120	1.248	1.6
Top	Fixed	165	5825	14.60	15	0.881	0.966	1.6
Back	Fixed	157	5785	14.53	15	0.672	0.749	1.6
R-Side	Fixed	157	5785	14.53	15	0.017	0.019	1.6
Test Mode: 802.11a - 5 GHz- MilDef Crete Inc. Aux Antenna, P/N: DK10 Aux Antenna								
Top	Fixed	149	5745	15.27	15.5	1.120	1.181	1.6
Top	Fixed	157	5785	15.10	15.5	1.180	1.294	1.6
Top	Fixed	165	5825	14.97	15.5	1.070	1.209	1.6
Back	Fixed	157	5785	15.10	15.5	0.358	0.393	1.6
L-Side	Fixed	157	5785	15.10	15.5	0.012	0.013	1.6
Test Mode: 802.11n (20M)-5GHz - MilDef Crete Inc. Main Antenna, P/N: DK10 Main Antenna								
Top	Fixed	149	5745	17.51	18	1.160	1.299	1.6
Top	Fixed	157	5785	17.39	18	1.150	1.323	1.6
Top	Fixed	165	5825	17.52	18	0.892	0.996	1.6
Test Mode: 802.11n (20M)-5GHz - MilDef Crete Inc. Aux Antenna, P/N: DK10 Aux Antenna								
Top	Fixed	149	5745	17.51	18	0.990	1.108	1.6
Top	Fixed	157	5785	17.39	18	1.090	1.254	1.6
Top	Fixed	165	5825	17.52	18	0.950	1.061	1.6
Test Mode: 802.11n (40M)-5GHz - MilDef Crete Inc. Main Antenna, P/N: DK10 Main Antenna								
Top	Fixed	151	5755	16.79	17	1.070	1.123	1.6
Top	Fixed	159	5795	16.76	17	0.928	0.981	1.6
Test Mode: 802.11n (40M)-5GHz - MilDef Crete Inc. Aux Antenna, P/N: DK10 Aux Antenna								
Top	Fixed	151	5755	16.79	17	0.917	0.962	1.6
Top	Fixed	159	5795	16.76	17	0.948	1.002	1.6
Note : According KDB 447498 D01, for antenna(s) located ≥ 5 cm from other side , the SAR is not required.								

10. SAR measurement variability

- 1) Repeated measurement is not required when the original highest measured SAR is < 0.80 W/kg; steps 2) through 4) do not apply.
- 2) When the original highest measured SAR is ≥ 0.80 W/kg, repeat that measurement once.
- 3) Perform a second repeated measurement only if the ratio of largest to smallest SAR for the original and first repeated measurements is > 1.20 or when the original or repeated measurement is ≥ 1.45 W/kg (~ 10% from the 1-g SAR limit).
- 4) Perform a third repeated measurement only if the original, first or second repeated measurement is ≥ 1.5 W/kg and the ratio of largest to smallest SAR for the original, first and second repeated measurements is > 1.20.

Frequency		SAR 1g (W/kg)						
Channel	MHz	Original	First Repeated		Second Repeated		Third Repeated	
			Value	Ratio	Value	Ratio	Value	Ratio
149	5745	1.19	1.23	1.033	N/A	N/A	N/A	N/A

Appendix**Appendix A. SAR System Check Data****Appendix B. SAR measurement Data****Appendix C. Test Setup Photographs & EUT Photographs****Appendix D. Probe Calibration Data****Appendix E. Dipole Calibration Data**

Appendix A. SAR System Check Data

Test Laboratory: QuieTek

Date/Time: 7/28/2013

System Performance Check_2450MHz-Body

DUT: Dipole 2450 MHz; Type: ALS-D-2450

Communication System: CW; Frequency: 2450 MHz; Communication System PAR: 0 dB

Medium parameters used: $f = 2450 \text{ MHz}$; $\sigma = 1.92 \text{ S/m}$; $\epsilon_r = 52.96$; $\rho = 1000 \text{ kg/m}^3$

Phantom section: Flat Section

Ambient Temperature ($^{\circ}\text{C}$) : 23.6, Liquid Temperature ($^{\circ}\text{C}$) : 22.4

Measurement Standard: DASY5 (IEEE/IEC/ANSI C63.19-2007)

DASY5 Configuration:

- Probe: EX3DV4 - SN3661; ConvF(7.35, 7.35, 7.35); Calibrated: 1/15/2013;
- Sensor-Surface: 3mm (Mechanical Surface Detection)
- Electronics: DAE4 Sn1207; Calibrated: 5/22/2013
- Phantom: SAM with left table; Type: SAM;
- Measurement SW: DASY52, Version 52.8 (5); SEMCAD X Version 14.6.8 (7028)

Configuration/2450MHz_Body/Area Scan (8x9x1): Measurement grid: $dx=12\text{mm}$, $dy=12\text{mm}$

Maximum value of SAR (measured) = 17.6 W/kg

Configuration/2450MHz_Body/Zoom Scan (7x7x7) (7x7x7)/Cube 0:

Measurement grid: $dx=5\text{mm}$, $dy=5\text{mm}$, $dz=5\text{mm}$

Reference Value = 83.018 V/m; Power Drift = 0.07 dB

Peak SAR (extrapolated) = 30.6 W/kg

SAR(1 g) = 14.6 W/kg; SAR(10 g) = 6.67 W/kg

Maximum value of SAR (measured) = 19.2 W/kg

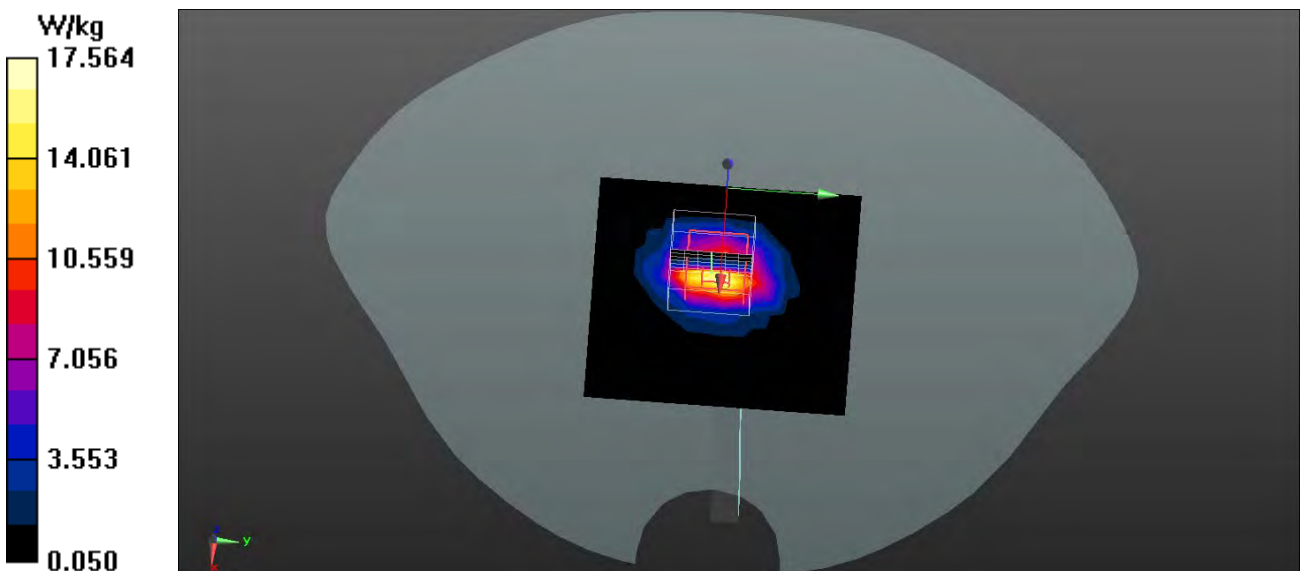

Test Laboratory: QuieTek

Date/Time: 7/27/2013

System Performance Check_5800MHz-Body

DUT: Dipole 5GHz; Type: D5GHzV2

Communication System: CW; Frequency: 5800 MHz; Communication System PAR: 0 dB

Medium parameters used: $f = 5800 \text{ MHz}$; $\sigma = 6.26 \text{ S/m}$; $\epsilon_r = 46.11$; $\rho = 1000 \text{ kg/m}^3$

Phantom section: Flat Section

Ambient Temperature (°C) : 22.8, Liquid Temperature (°C) : 21.1

Measurement Standard: DASYS (IEEE/IEC/ANSI C63.19-2007)

DASY5 Configuration:

- Probe: EX3DV4 - SN3661; ConvF(3.97, 3.97, 3.97); Calibrated: 1/15/2013;
- Sensor-Surface: 1.4mm (Mechanical Surface Detection)
- Electronics: DAE4 Sn1207; Calibrated: 5/22/2013
- Phantom: SAM with right table; Type: SAM;
- Measurement SW: DASY52, Version 52.8 (5); SEMCAD X Version 14.6.8 (7028)

Configuration/5800MHz-Body 100mW/Area Scan (8x8x1): Measurement grid:

$dx=10\text{mm}$, $dy=10\text{mm}$

Maximum value of SAR (measured) = 12.0 W/kg

Configuration/5800MHz-Body 100mW/Zoom Scan (7x7x12), dist=2mm

(7x7x12)/Cube 0: Measurement grid: $dx=4\text{mm}$, $dy=4\text{mm}$, $dz=2\text{mm}$

Reference Value = 67.173 V/m; Power Drift = 0.12 dB

Peak SAR (extrapolated) = 33.7 W/kg

SAR(1 g) = 7.57 W/kg; SAR(10 g) = 2.02 W/kg

Maximum value of SAR (measured) = 20.1 W/kg

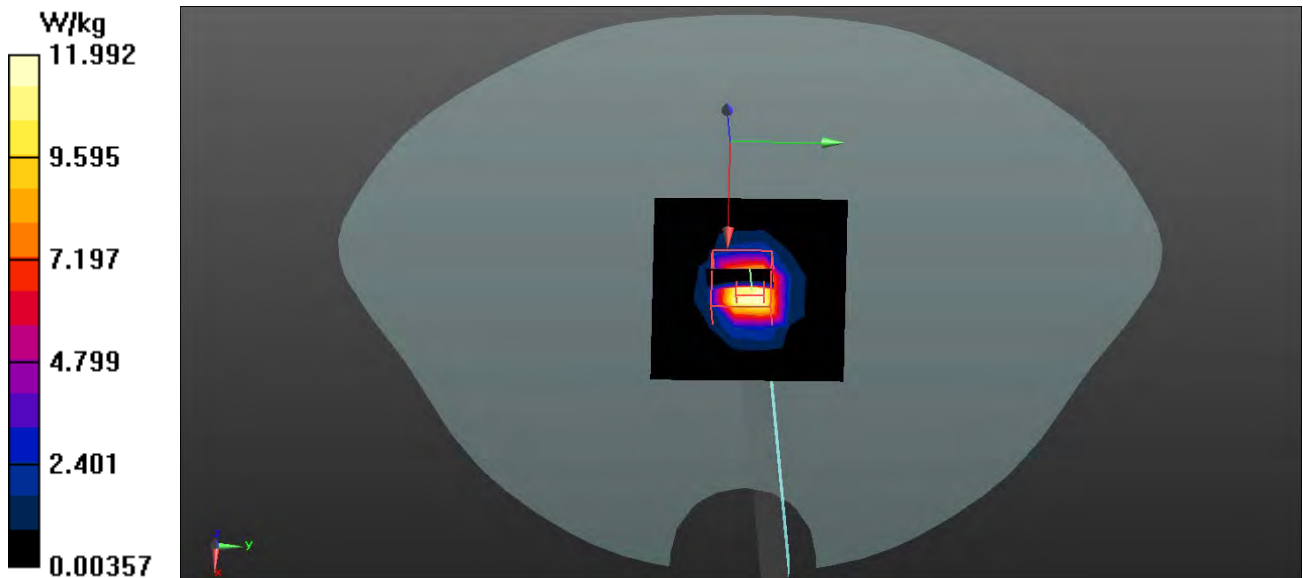

Appendix B. SAR measurement Data

Antenna Kit : MilDef Crete Inc. Main Antenna, P/N: DK10 Main Antenna

Test Laboratory: QuieTek

Date/Time: 7/28/2013

802.11b_6-Top TX1

DUT: Handheld Computer; Type: DK10

Communication System: WLAN 2.4G; Frequency: 2437 MHz;

Communication System PAR: 0 dB

Medium parameters used: $f = 2437$ MHz; $\sigma = 1.93$ S/m; $\epsilon_r = 51.46$; $\rho = 1000$ kg/m³

Phantom section: Flat Section

Ambient Temperature (°C) : 23.6, Liquid Temperature (°C) : 22.4

Measurement Standard: DASYS (IEEE/IEC/ANSI C63.19-2007)

DASY5 Configuration:

- Probe: EX3DV4 - SN3661; ConvF(7.35, 7.35, 7.35); Calibrated: 1/15/2013;
- Sensor-Surface: 3mm (Mechanical Surface Detection)
- Electronics: DAE4 Sn1207; Calibrated: 5/22/2013
- Phantom: SAM with left table; Type: SAM;
- Measurement SW: DASYS2, Version 52.8 (5); SEMCAD X Version 14.6.8 (7028)

Configuration/Body/Area Scan (7x13x1): Measurement grid: dx=12mm, dy=12mm
 Maximum value of SAR (measured) = 0.706 W/kg

Configuration/Body/Zoom Scan (7x7x7) (7x7x7)/Cube 0: Measurement grid:
 dx=5mm, dy=5mm, dz=5mm
 Reference Value = 12.984 V/m; Power Drift = 0.01 dB
 Peak SAR (extrapolated) = 1.20 W/kg
SAR(1 g) = 0.607 W/kg; SAR(10 g) = 0.319 W/kg
 Maximum value of SAR (measured) = 0.759 W/kg

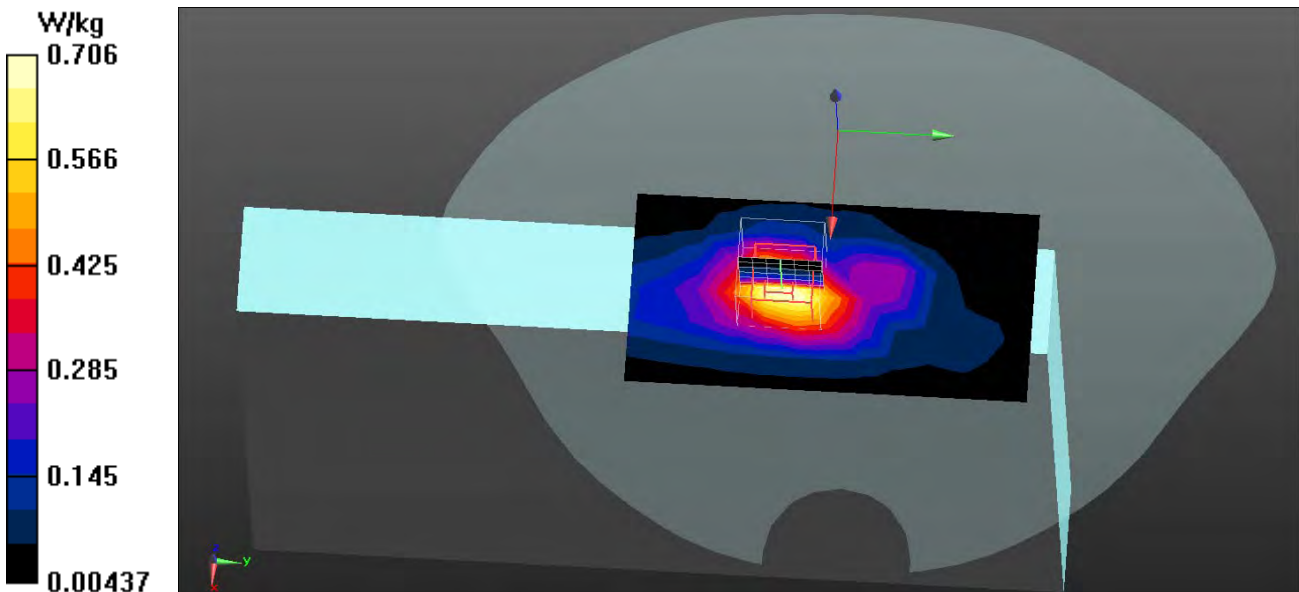

Test Laboratory: QuieTek

Date/Time: 7/28/2013

802.11b_6-Back TX1

DUT: Handheld Computer; Type: DK10

Communication System: WLAN 2.4G; Frequency: 2437 MHz;

Communication System PAR: 0 dB

Medium parameters used: $f = 2437$ MHz; $\sigma = 1.93$ S/m; $\epsilon_r = 51.46$; $\rho = 1000$ kg/m³

Phantom section: Flat Section

Ambient Temperature (°C) : 23.6, Liquid Temperature (°C) : 22.4

Measurement Standard: DASYS (IEEE/IEC/ANSI C63.19-2007)

DASY5 Configuration:

- Probe: EX3DV4 - SN3661; ConvF(7.35, 7.35, 7.35); Calibrated: 1/15/2013;
- Sensor-Surface: 3mm (Mechanical Surface Detection)
- Electronics: DAE4 Sn1207; Calibrated: 5/22/2013
- Phantom: SAM with left table; Type: SAM;
- Measurement SW: DASY52, Version 52.8 (5); SEMCAD X Version 14.6.8 (7028)

Configuration/Body/Area Scan (7x13x1): Measurement grid: dx=12mm, dy=12mm

Maximum value of SAR (measured) = 0.612 W/kg

Configuration/Body/Zoom Scan (7x7x7) (7x7x7)/Cube 0: Measurement grid:

dx=5mm, dy=5mm, dz=5mm

Reference Value = 15.098 V/m; Power Drift = -0.13 dB

Peak SAR (extrapolated) = 1.22 W/kg

SAR(1 g) = 0.596 W/kg; SAR(10 g) = 0.294 W/kg

Maximum value of SAR (measured) = 0.772 W/kg

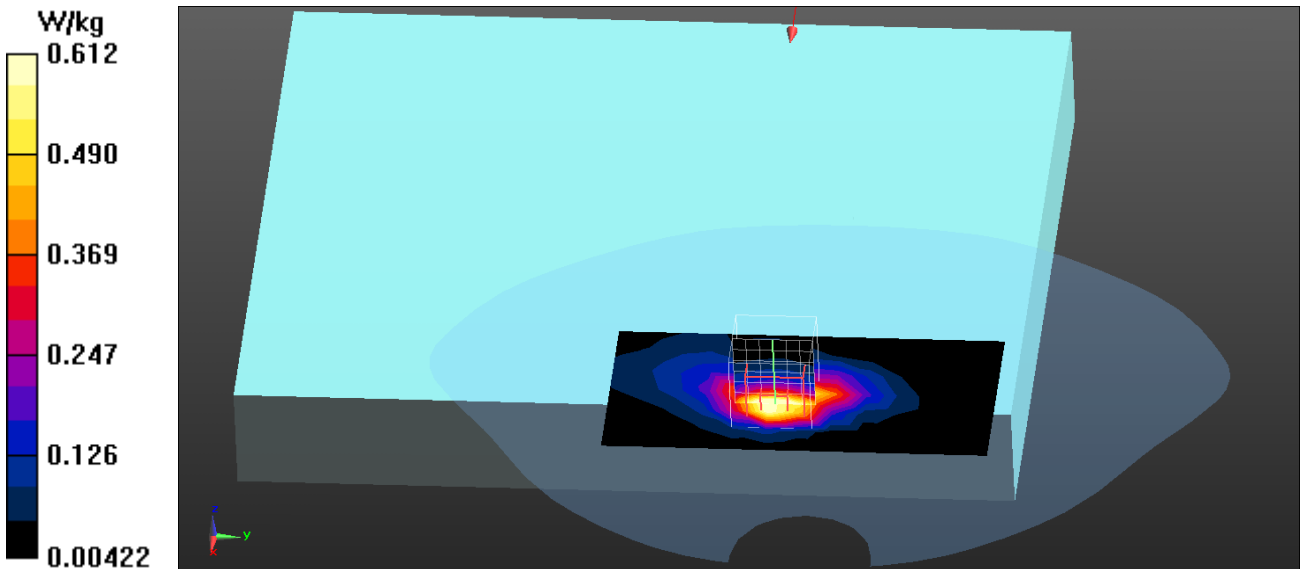

Test Laboratory: QuieTek

Date/Time: 7/28/2013

802.11b_6-Right-Side TX1

DUT: Handheld Computer; Type: DK10

Communication System: WLAN 2.4G; Frequency: 2437 MHz;

Communication System PAR: 0 dB

Medium parameters used: $f = 2437$ MHz; $\sigma = 1.93$ S/m; $\epsilon_r = 51.46$; $\rho = 1000$ kg/m³

Phantom section: Flat Section

Ambient Temperature (°C) : 23.6, Liquid Temperature (°C) : 22.4

Measurement Standard: DASYS (IEEE/IEC/ANSI C63.19-2007)

DASY5 Configuration:

- Probe: EX3DV4 - SN3661; ConvF(7.35, 7.35, 7.35); Calibrated: 1/15/2013;
- Sensor-Surface: 3mm (Mechanical Surface Detection)
- Electronics: DAE4 Sn1207; Calibrated: 5/22/2013
- Phantom: SAM with left table; Type: SAM;
- Measurement SW: DASY52, Version 52.8 (5); SEMCAD X Version 14.6.8 (7028)

Configuration/Body/Area Scan (7x9x1): Measurement grid: dx=12mm, dy=12mm

Maximum value of SAR (measured) = 0.0340 W/kg

Configuration/Body/Zoom Scan (7x7x7) (7x7x7)/Cube 0: Measurement grid:

dx=5mm, dy=5mm, dz=5mm

Reference Value = 3.767 V/m; Power Drift = 0.08 dB

Peak SAR (extrapolated) = 0.0630 W/kg

SAR(1 g) = 0.030 W/kg; SAR(10 g) = 0.016 W/kg

Maximum value of SAR (measured) = 0.0400 W/kg

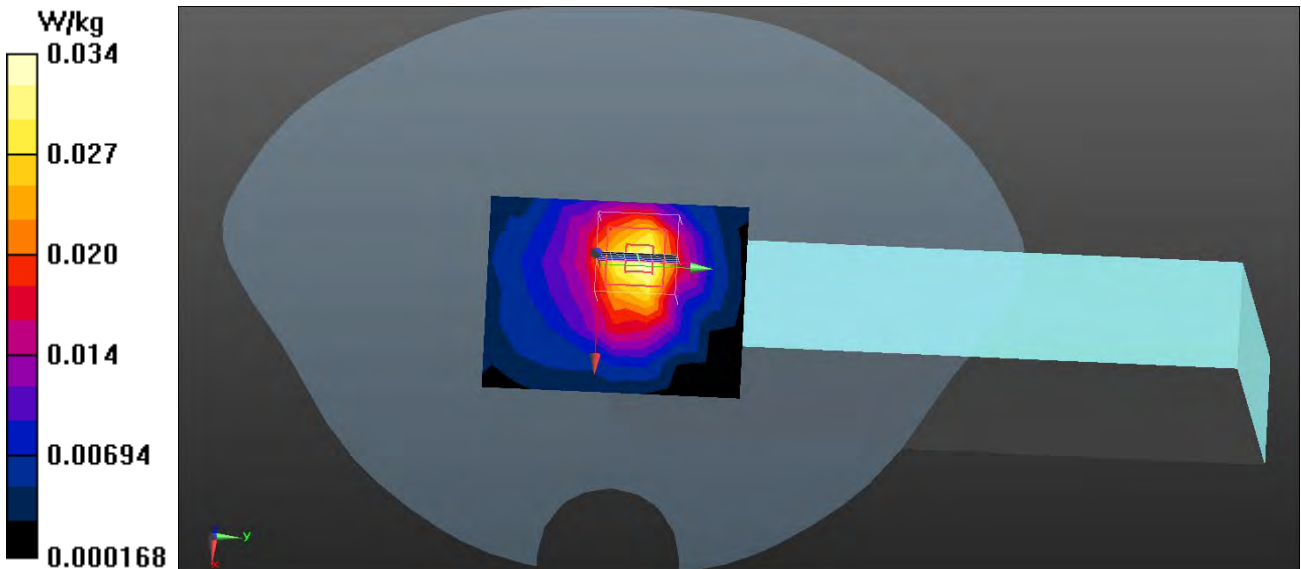

Antenna Kit : MilDef Crete Inc. Aux Antenna, P/N: DK10 Aux Antenna

Test Laboratory: QuieTek

Date/Time: 7/28/2013

802.11b_6-Top TX2

DUT: Handheld Computer; Type: DK10

Communication System: WLAN 2.4G; Frequency: 2437 MHz;

Communication System PAR: 0 dB

Medium parameters used: $f = 2437$ MHz; $\sigma = 1.93$ S/m; $\epsilon_r = 51.46$; $\rho = 1000$ kg/m³

Phantom section: Flat Section

Ambient Temperature (°C) : 23.6, Liquid Temperature (°C) : 22.4

Measurement Standard: DASYS (IEEE/IEC/ANSI C63.19-2007)

DASY5 Configuration:

- Probe: EX3DV4 - SN3661; ConvF(7.35, 7.35, 7.35); Calibrated: 1/15/2013;
- Sensor-Surface: 3mm (Mechanical Surface Detection)
- Electronics: DAE4 Sn1207; Calibrated: 5/22/2013
- Phantom: SAM with left table; Type: SAM;
- Measurement SW: DASY52, Version 52.8 (5); SEMCAD X Version 14.6.8 (7028)

Configuration/Body/Area Scan (7x13x1): Measurement grid: dx=12mm, dy=12mm
 Maximum value of SAR (measured) = 0.923 W/kg

Configuration/Body/Zoom Scan (7x7x7) (7x7x7)/Cube 0: Measurement grid:
 dx=5mm, dy=5mm, dz=5mm
 Reference Value = 12.837 V/m; Power Drift = -0.11 dB
 Peak SAR (extrapolated) = 1.42 W/kg
SAR(1 g) = 0.672 W/kg; SAR(10 g) = 0.291 W/kg
 Maximum value of SAR (measured) = 0.916 W/kg

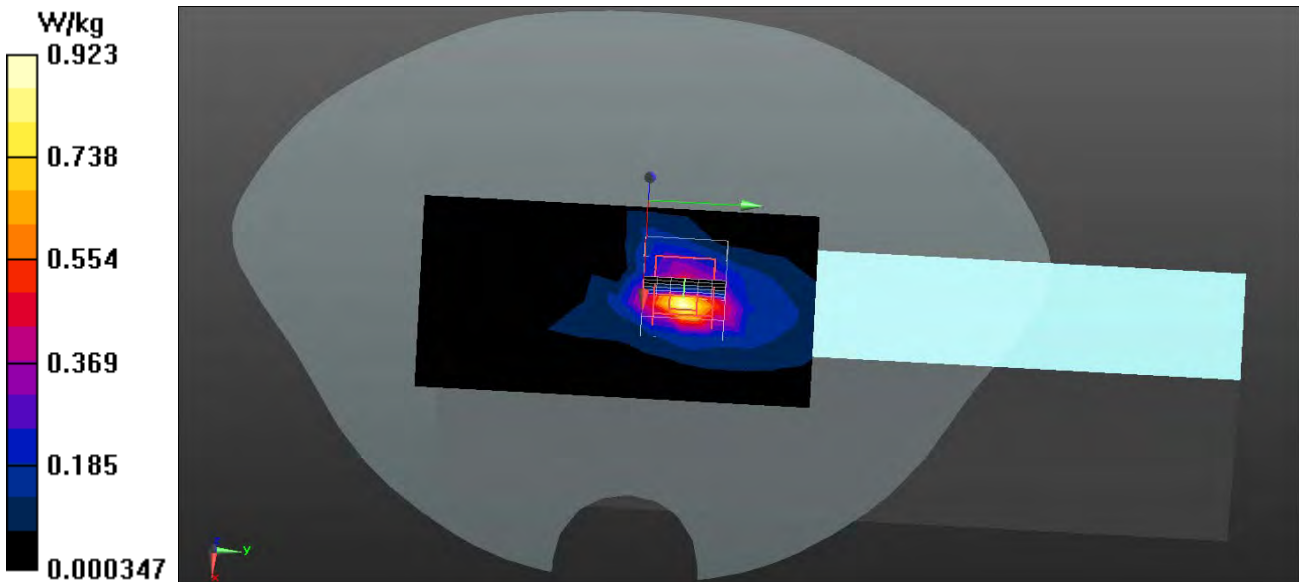

Test Laboratory: QuieTek

Date/Time: 7/28/2013

802.11b_6-Back TX2

DUT: Handheld Computer; Type: DK10

Communication System: WLAN 2.4G; Frequency: 2437 MHz;

Communication System PAR: 0 dB

Medium parameters used: $f = 2437$ MHz; $\sigma = 1.93$ S/m; $\epsilon_r = 51.46$; $\rho = 1000$ kg/m³

Phantom section: Flat Section

Ambient Temperature (°C) : 23.6, Liquid Temperature (°C) : 22.4

Measurement Standard: DASYS (IEEE/IEC/ANSI C63.19-2007)

DASY5 Configuration:

- Probe: EX3DV4 - SN3661; ConvF(7.35, 7.35, 7.35); Calibrated: 1/15/2013;
- Sensor-Surface: 3mm (Mechanical Surface Detection)
- Electronics: DAE4 Sn1207; Calibrated: 5/22/2013
- Phantom: SAM with left table; Type: SAM;
- Measurement SW: DASY52, Version 52.8 (5); SEMCAD X Version 14.6.8 (7028)

Configuration/Body/Area Scan (7x13x1): Measurement grid: dx=12mm, dy=12mm
 Maximum value of SAR (measured) = 0.676 W/kg

Configuration/Body/Zoom Scan (7x7x7) (7x7x7)/Cube 0: Measurement grid:
 dx=5mm, dy=5mm, dz=5mm

Reference Value = 7.588 V/m; Power Drift = -0.10 dB

Peak SAR (extrapolated) = 1.19 W/kg

SAR(1 g) = 0.590 W/kg; SAR(10 g) = 0.287 W/kg

Maximum value of SAR (measured) = 0.762 W/kg

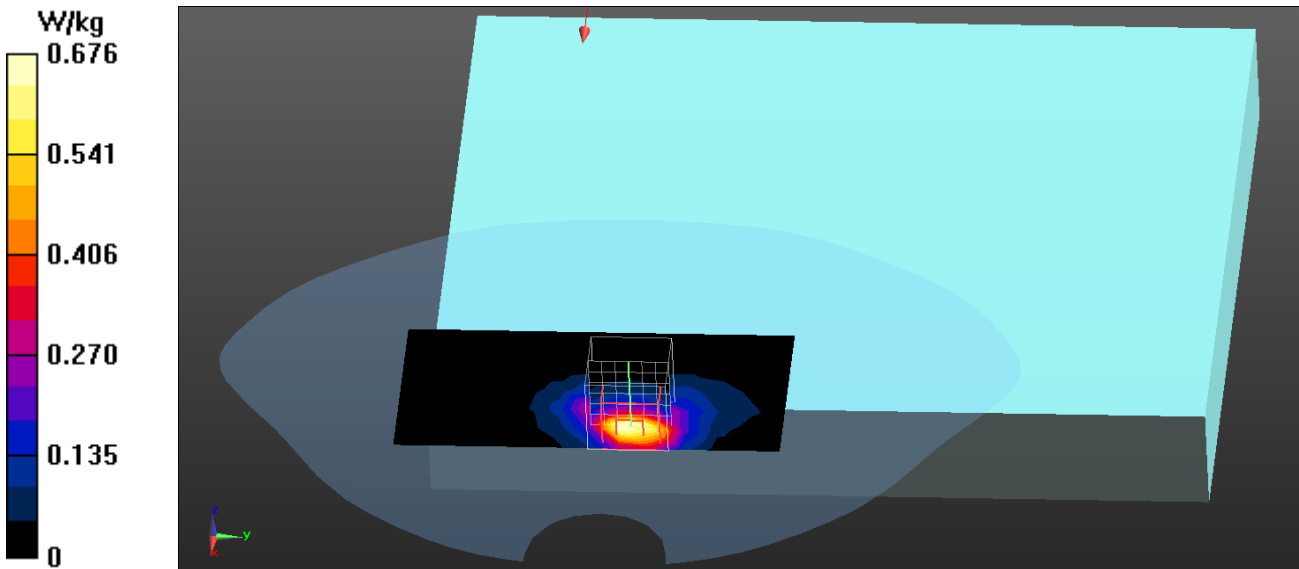

Test Laboratory: Quietek

Date/Time: 7/28/2013

802.11b_6-Left-Side TX2**DUT: Handheld Computer; Type: DK10**

Communication System: WLAN 2.4G; Frequency: 2437 MHz;

Communication System PAR: 0 dB

Medium parameters used: $f = 2437$ MHz; $\sigma = 1.93$ S/m; $\epsilon_r = 51.46$; $\rho = 1000$ kg/m³

Phantom section: Flat Section

Ambient Temperature (°C) : 23.6, Liquid Temperature (°C) : 22.4

Measurement Standard: DASYS (IEEE/IEC/ANSI C63.19-2007)

DASY5 Configuration:

- Probe: EX3DV4 - SN3661; ConvF(7.35, 7.35, 7.35); Calibrated: 1/15/2013;
- Sensor-Surface: 3mm (Mechanical Surface Detection)
- Electronics: DAE4 Sn1207; Calibrated: 5/22/2013
- Phantom: SAM with left table; Type: SAM;
- Measurement SW: DASY52, Version 52.8 (5); SEMCAD X Version 14.6.8 (7028)

Configuration/Body/Area Scan (7x9x1): Measurement grid: dx=12mm, dy=12mm

Maximum value of SAR (measured) = 0.0443 W/kg

Configuration/Body/Zoom Scan (7x7x7) (7x7x7)/Cube 0: Measurement grid:

dx=5mm, dy=5mm, dz=5mm

Reference Value = 4.113 V/m; Power Drift = 0.11 dB

Peak SAR (extrapolated) = 0.0730 W/kg

SAR(1 g) = 0.035 W/kg; SAR(10 g) = 0.016 W/kg

Maximum value of SAR (measured) = 0.0454 W/kg

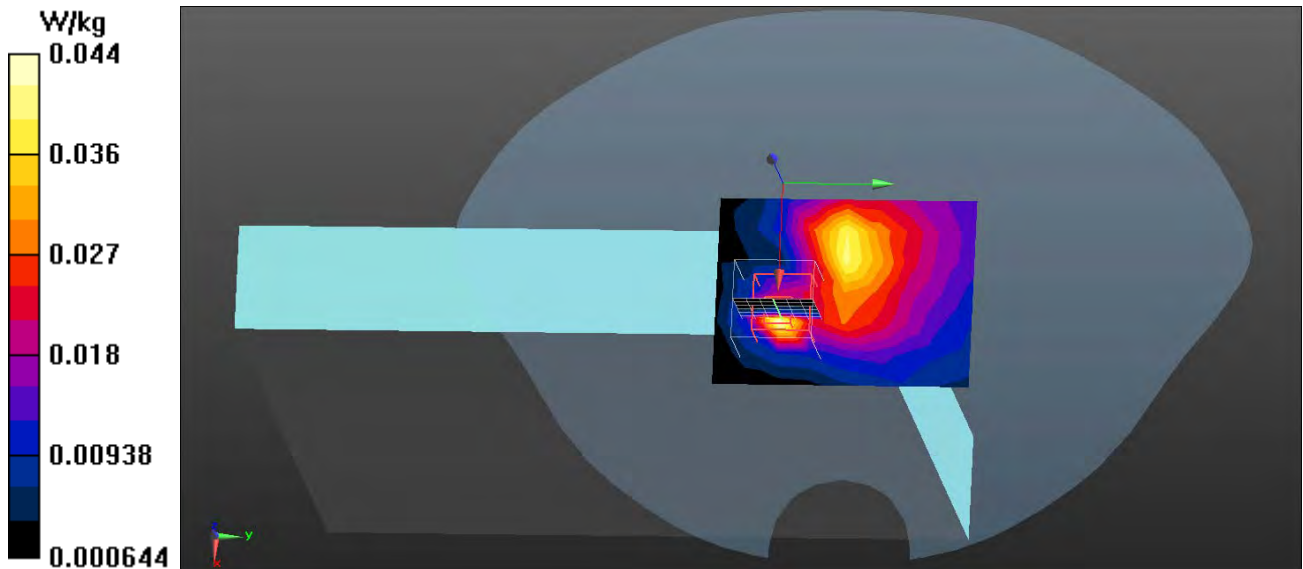

Antenna Kit : MilDef Crete Inc. Main Antenna, P/N: DK10 Main Antenna

Test Laboratory: QuieTek

Date/Time: 7/28/2013

802.11g_6-Top TX1

DUT: Tablet PC; Type: DK10

Communication System: WLAN 2.4G; Frequency: 2437 MHz;

Communication System PAR: 0 dB

Medium parameters used: $f = 2437$ MHz; $\sigma = 1.93$ S/m; $\epsilon_r = 51.46$; $\rho = 1000$ kg/m³

Phantom section: Flat Section

Ambient Temperature (°C) : 23.6, Liquid Temperature (°C) : 22.4

Measurement Standard: DASYS (IEEE/IEC/ANSI C63.19-2007)

DASY5 Configuration:

- Probe: EX3DV4 - SN3661; ConvF(7.35, 7.35, 7.35); Calibrated: 1/15/2013;
- Sensor-Surface: 3mm (Mechanical Surface Detection)
- Electronics: DAE4 Sn1207; Calibrated: 5/22/2013
- Phantom: SAM with left table; Type: SAM;
- Measurement SW: DASY52, Version 52.8 (5); SEMCAD X Version 14.6.8 (7028)

Configuration/Body/Area Scan (7x13x1): Measurement grid: dx=12mm, dy=12mm

Maximum value of SAR (measured) = 0.737 W/kg

Configuration/Body/Zoom Scan (7x7x7) (7x7x7)/Cube 0: Measurement grid:

dx=5mm, dy=5mm, dz=5mm

Reference Value = 13.107 V/m; Power Drift = 0.03 dB

Peak SAR (extrapolated) = 1.26 W/kg

SAR(1 g) = 0.632 W/kg; SAR(10 g) = 0.331 W/kg

Maximum value of SAR (measured) = 0.792 W/kg

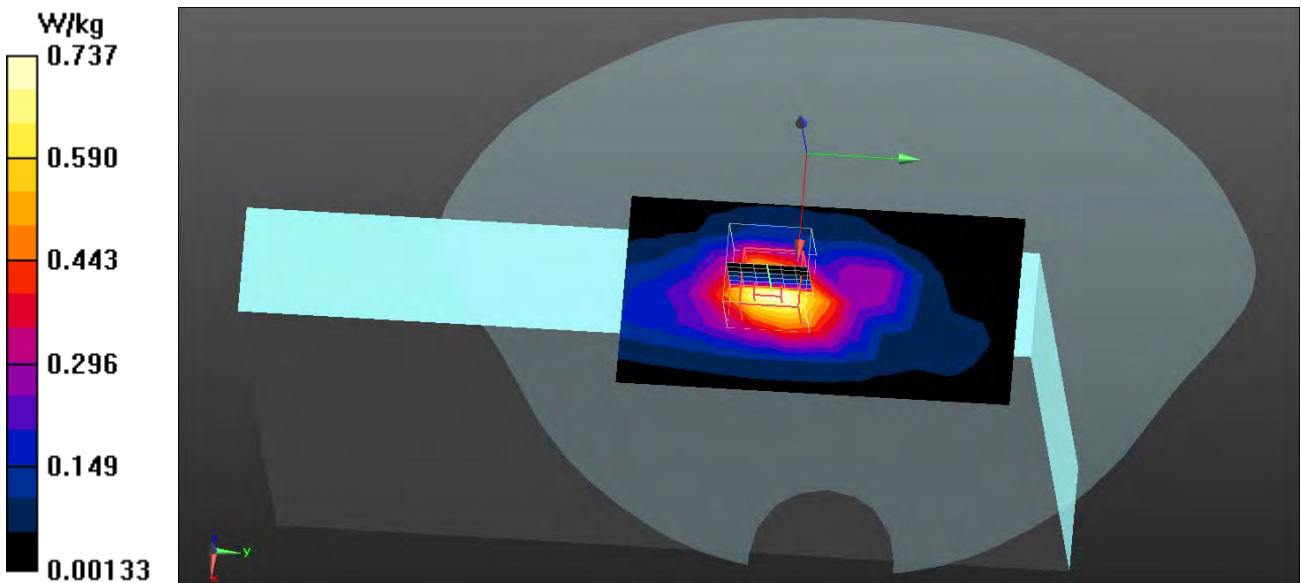

Antenna Kit : MilDef Crete Inc. Aux Antenna, P/N: DK10 Aux Antenna

Test Laboratory: QuieTek

Date/Time: 7/28/2013

802.11g_1-Top TX2

DUT: Handheld Computer; Type: DK10

Communication System: WLAN 2.4G; Frequency: 2412 MHz;

Communication System PAR: 0 dB

Medium parameters used: $f = 2412$ MHz; $\sigma = 1.91$ S/m; $\epsilon_r = 52.03$; $\rho = 1000$ kg/m³

Phantom section: Flat Section

Ambient Temperature (°C) : 23.6, Liquid Temperature (°C) : 22.4

Measurement Standard: DASY5 (IEEE/IEC/ANSI C63.19-2007)

DASY5 Configuration:

- Probe: EX3DV4 - SN3661; ConvF(7.35, 7.35, 7.35); Calibrated: 1/15/2013;
- Sensor-Surface: 3mm (Mechanical Surface Detection)
- Electronics: DAE4 Sn1207; Calibrated: 5/22/2013
- Phantom: SAM with left table; Type: SAM;
- Measurement SW: DASY52, Version 52.8 (5); SEMCAD X Version 14.6.8 (7028)

Configuration/Body/Area Scan (7x13x1): Measurement grid: dx=12mm, dy=12mm

Maximum value of SAR (measured) = 1.15 W/kg

Configuration/Body/Zoom Scan (7x7x7) (7x7x7)/Cube 0: Measurement grid:

dx=5mm, dy=5mm, dz=5mm

Reference Value = 14.203 V/m; Power Drift = -0.10 dB

Peak SAR (extrapolated) = 1.77 W/kg

SAR(1 g) = 0.793 W/kg; SAR(10 g) = 0.345 W/kg

Maximum value of SAR (measured) = 1.16 W/kg

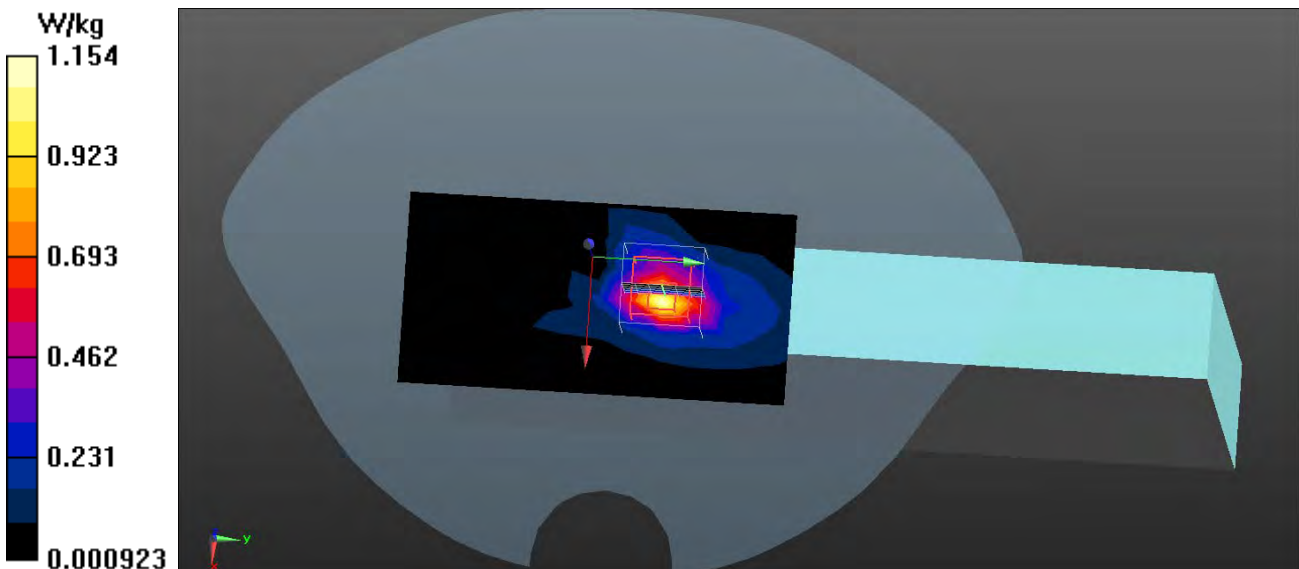

Test Laboratory: QuieTek

Date/Time: 7/28/2013

802.11g_6-Top TX2

DUT: Handheld Computer; Type: DK10

Communication System: WLAN 2.4G; Frequency: 2437 MHz;

Communication System PAR: 0 dB

Medium parameters used: $f = 2437$ MHz; $\sigma = 1.93$ S/m; $\epsilon_r = 51.46$; $\rho = 1000$ kg/m³

Phantom section: Flat Section

Ambient Temperature (°C) : 23.6, Liquid Temperature (°C) : 22.4

Measurement Standard: DASYS (IEEE/IEC/ANSI C63.19-2007)

DASY5 Configuration:

- Probe: EX3DV4 - SN3661; ConvF(7.35, 7.35, 7.35); Calibrated: 1/15/2013;
- Sensor-Surface: 3mm (Mechanical Surface Detection)
- Electronics: DAE4 Sn1207; Calibrated: 5/22/2013
- Phantom: SAM with left table; Type: SAM;
- Measurement SW: DASY52, Version 52.8 (5); SEMCAD X Version 14.6.8 (7028)

Configuration/Body/Area Scan (7x13x1): Measurement grid: dx=12mm, dy=12mm
 Maximum value of SAR (measured) = 1.12 W/kg

Configuration/Body/Zoom Scan (7x7x7) (7x7x7)/Cube 0: Measurement grid:
 dx=5mm, dy=5mm, dz=5mm

Reference Value = 13.733 V/m; Power Drift = 0.17 dB

Peak SAR (extrapolated) = 1.75 W/kg

SAR(1 g) = 0.786 W/kg; SAR(10 g) = 0.347 W/kg

Maximum value of SAR (measured) = 1.18 W/kg

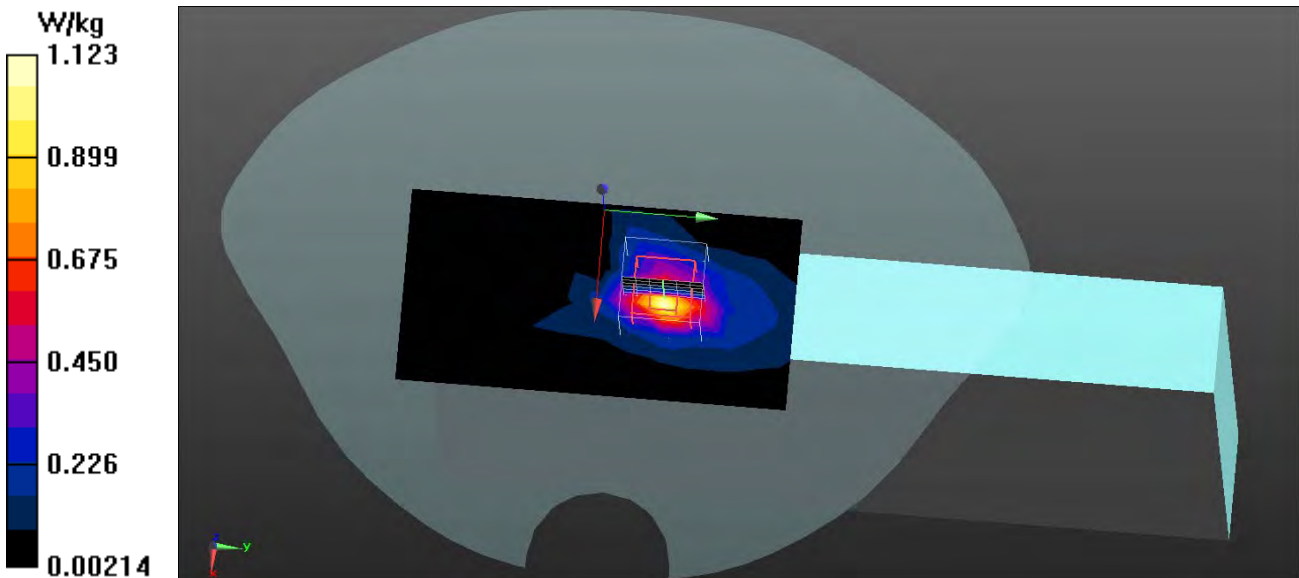

Test Laboratory: QuieTek

Date/Time: 7/28/2013

802.11g_11-Top TX2

DUT: Handheld Computer; Type: DK10

Communication System: WLAN 2.4G; Frequency: 2462 MHz;

Communication System PAR: 0 dB

Medium parameters used: $f = 2462 \text{ MHz}$; $\sigma = 1.96 \text{ S/m}$; $\epsilon_r = 51.33$; $\rho = 1000 \text{ kg/m}^3$

Phantom section: Flat Section

Ambient Temperature (°C) : 23.6, Liquid Temperature (°C) : 22.4

Measurement Standard: DASYS (IEEE/IEC/ANSI C63.19-2007)

DASY5 Configuration:

- Probe: EX3DV4 - SN3661; ConvF(7.35, 7.35, 7.35); Calibrated: 1/15/2013;
- Sensor-Surface: 3mm (Mechanical Surface Detection)
- Electronics: DAE4 Sn1207; Calibrated: 5/22/2013
- Phantom: SAM with left table; Type: SAM;
- Measurement SW: DASY52, Version 52.8 (5); SEMCAD X Version 14.6.8 (7028)

Configuration/Body/Area Scan (7x13x1): Measurement grid: $dx=12\text{mm}$, $dy=12\text{mm}$
 Maximum value of SAR (measured) = 0.976 W/kg

Configuration/Body/Zoom Scan (7x7x7) (7x7x7)/Cube 0: Measurement grid:
 $dx=5\text{mm}$, $dy=5\text{mm}$, $dz=5\text{mm}$

Reference Value = 13.304 V/m; Power Drift = -0.11 dB

Peak SAR (extrapolated) = 1.49 W/kg

SAR(1 g) = 0.696 W/kg; SAR(10 g) = 0.298 W/kg

Maximum value of SAR (measured) = 0.943 W/kg

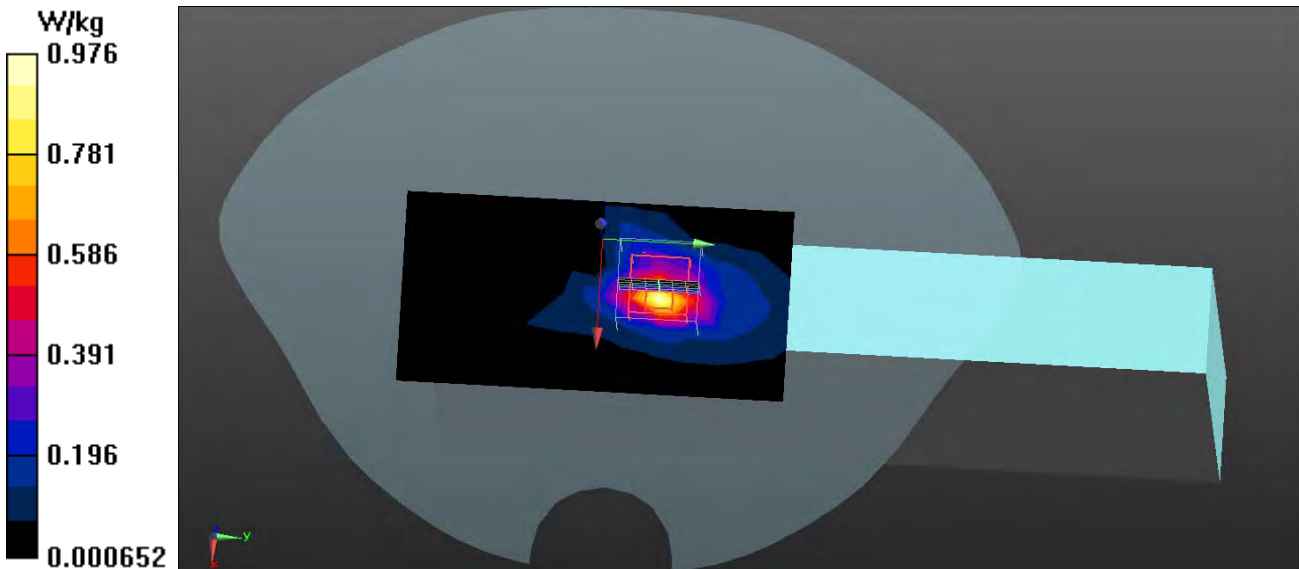

Antenna Kit : MilDef Crete Inc. Main Antenna, P/N: DK10 Main Antenna

Test Laboratory: QuieTek

Date/Time: 7/28/2013

802.11n-20M_6-Top TX1

DUT: Handheld Computer; Type: DK10

Communication System: WLAN 2.4G; Frequency: 2437 MHz;

Communication System PAR: 0 dB

Medium parameters used: $f = 2437$ MHz; $\sigma = 1.93$ S/m; $\epsilon_r = 51.46$; $\rho = 1000$ kg/m³

Phantom section: Flat Section

Ambient Temperature (°C) : 23.6, Liquid Temperature (°C) : 22.4

Measurement Standard: DASYS (IEEE/IEC/ANSI C63.19-2007)

DASY5 Configuration:

- Probe: EX3DV4 - SN3661; ConvF(7.35, 7.35, 7.35); Calibrated: 1/15/2013;
- Sensor-Surface: 3mm (Mechanical Surface Detection)
- Electronics: DAE4 Sn1207; Calibrated: 5/22/2013
- Phantom: SAM with left table; Type: SAM;
- Measurement SW: DASY52, Version 52.8 (5); SEMCAD X Version 14.6.8 (7028)

Configuration/Body/Area Scan (7x13x1): Measurement grid: dx=12mm, dy=12mm

Maximum value of SAR (measured) = 0.611 W/kg

Configuration/Body/Zoom Scan (7x7x7) (7x7x7)/Cube 0: Measurement grid:

dx=5mm, dy=5mm, dz=5mm

Reference Value = 12.727 V/m; Power Drift = -0.16 dB

Peak SAR (extrapolated) = 1.03 W/kg

SAR(1 g) = 0.516 W/kg; SAR(10 g) = 0.269 W/kg

Maximum value of SAR (measured) = 0.649 W/kg

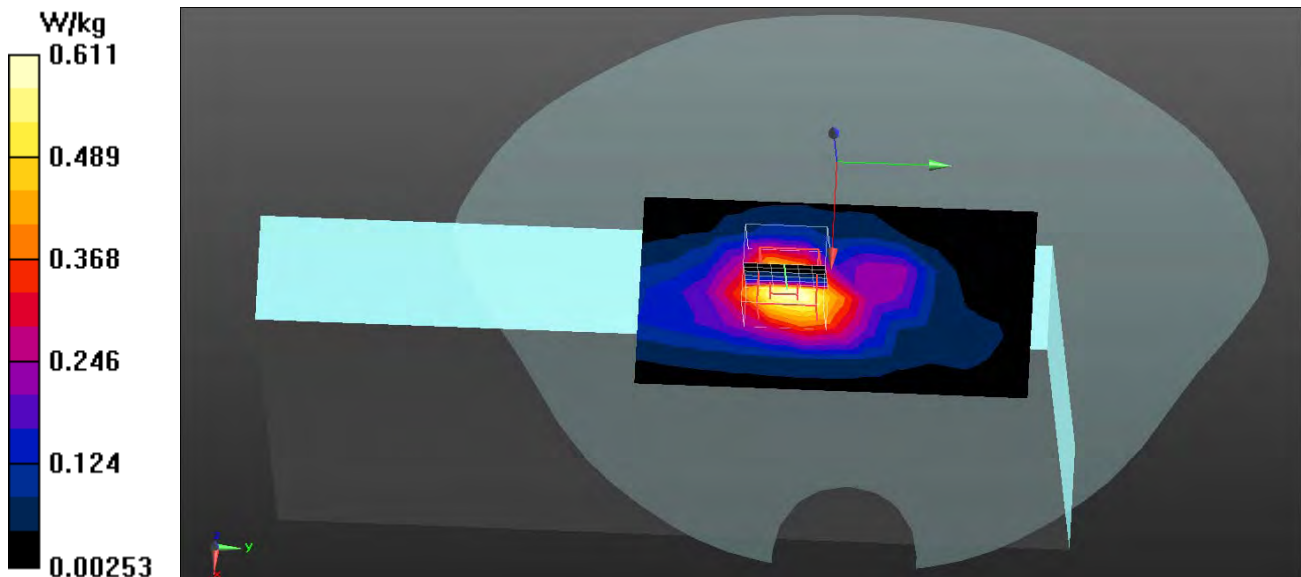

Antenna Kit : MilDef Crete Inc. Aux Antenna, P/N: DK10 Aux Antenna

Test Laboratory: QuieTek

Date/Time: 7/28/2013

802.11n-20M_6-Top TX2

DUT: Handheld Computer; Type: DK10

Communication System: WLAN 2.4G; Frequency: 2437 MHz;

Communication System PAR: 0 dB

Medium parameters used: $f = 2437$ MHz; $\sigma = 1.93$ S/m; $\epsilon_r = 51.46$; $\rho = 1000$ kg/m³

Phantom section: Flat Section

Ambient Temperature (°C) : 23.6, Liquid Temperature (°C) : 22.4

Measurement Standard: DASYS (IEEE/IEC/ANSI C63.19-2007)

DASY5 Configuration:

- Probe: EX3DV4 - SN3661; ConvF(7.35, 7.35, 7.35); Calibrated: 1/15/2013;
- Sensor-Surface: 3mm (Mechanical Surface Detection)
- Electronics: DAE4 Sn1207; Calibrated: 5/22/2013
- Phantom: SAM with left table; Type: SAM;
- Measurement SW: DASY52, Version 52.8 (5); SEMCAD X Version 14.6.8 (7028)

Configuration/Body/Area Scan (7x13x1): Measurement grid: dx=12mm, dy=12mm

Maximum value of SAR (measured) = 1.09 W/kg

Configuration/Body/Zoom Scan (7x7x7) (7x7x7)/Cube 0: Measurement grid:

dx=5mm, dy=5mm, dz=5mm

Reference Value = 13.882 V/m; Power Drift = -0.17 dB

Peak SAR (extrapolated) = 1.65 W/kg

SAR(1 g) = 0.740 W/kg; SAR(10 g) = 0.318 W/kg

Maximum value of SAR (measured) = 1.11 W/kg

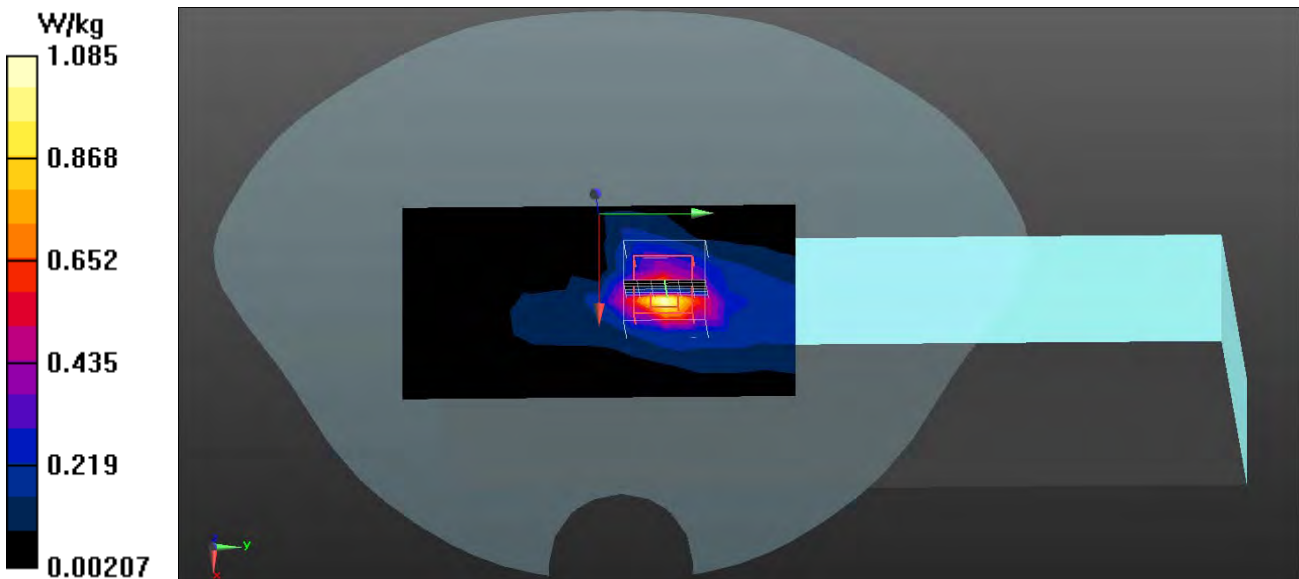

Antenna Kit : MilDef Crete Inc. Main Antenna, P/N: DK10 Main Antenna

Test Laboratory: QuieTek

Date/Time: 7/28/2013

802.11n-40M_6-Top TX1

DUT: Handheld Computer; Type: DK10

Communication System: WLAN 2.4G; Frequency: 2437 MHz;

Communication System PAR: 0 dB

Medium parameters used: $f = 2437$ MHz; $\sigma = 1.93$ S/m; $\epsilon_r = 51.46$; $\rho = 1000$ kg/m³

Phantom section: Flat Section

Ambient Temperature (°C) : 23.6, Liquid Temperature (°C) : 22.4

Measurement Standard: DASY5 (IEEE/IEC/ANSI C63.19-2007)

DASY5 Configuration:

- Probe: EX3DV4 - SN3661; ConvF(7.35, 7.35, 7.35); Calibrated: 1/15/2013;
- Sensor-Surface: 3mm (Mechanical Surface Detection)
- Electronics: DAE4 Sn1207; Calibrated: 5/22/2013
- Phantom: SAM with left table; Type: SAM;
- Measurement SW: DASY52, Version 52.8 (5); SEMCAD X Version 14.6.8 (7028)

Configuration/Body/Area Scan (7x13x1): Measurement grid: dx=12mm, dy=12mm

Maximum value of SAR (measured) = 0.567 W/kg

Configuration/Body/Zoom Scan (7x7x7) (7x7x7)/Cube 0: Measurement grid:

dx=5mm, dy=5mm, dz=5mm

Reference Value = 11.463 V/m; Power Drift = -0.01 dB

Peak SAR (extrapolated) = 0.971 W/kg

SAR(1 g) = 0.485 W/kg; SAR(10 g) = 0.252 W/kg

Maximum value of SAR (measured) = 0.610 W/kg

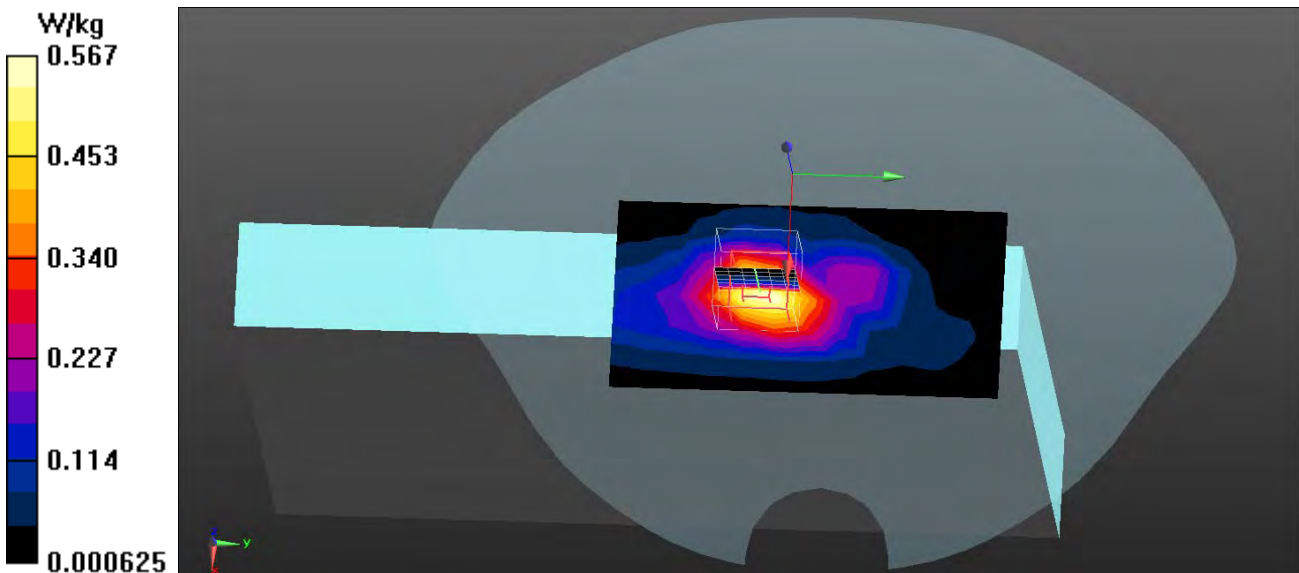

Antenna Kit : MilDef Crete Inc. Aux Antenna, P/N: DK10 Aux Antenna

Test Laboratory: QuieTek

Date/Time: 7/28/2013

802.11n-40M_6-Top TX2

DUT: Handheld Computer; Type: DK10

Communication System: WLAN 2.4G; Frequency: 2437 MHz;

Communication System PAR: 0 dB

Medium parameters used: $f = 2437$ MHz; $\sigma = 1.93$ S/m; $\epsilon_r = 51.46$; $\rho = 1000$ kg/m³

Phantom section: Flat Section

Ambient Temperature (°C) : 23.6, Liquid Temperature (°C) : 22.4

Measurement Standard: DASY5 (IEEE/IEC/ANSI C63.19-2007)

DASY5 Configuration:

- Probe: EX3DV4 - SN3661; ConvF(7.35, 7.35, 7.35); Calibrated: 1/15/2013;
- Sensor-Surface: 3mm (Mechanical Surface Detection)
- Electronics: DAE4 Sn1207; Calibrated: 5/22/2013
- Phantom: SAM with left table; Type: SAM;
- Measurement SW: DASY52, Version 52.8 (5); SEMCAD X Version 14.6.8 (7028)

Configuration/Body/Area Scan (7x13x1): Measurement grid: dx=12mm, dy=12mm

Maximum value of SAR (measured) = 1.10 W/kg

Configuration/Body/Zoom Scan (7x7x7) (7x7x7)/Cube 0: Measurement grid:

dx=5mm, dy=5mm, dz=5mm

Reference Value = 13.891 V/m; Power Drift = -0.04 dB

Peak SAR (extrapolated) = 1.69 W/kg

SAR(1 g) = 0.746 W/kg; SAR(10 g) = 0.325 W/kg

Maximum value of SAR (measured) = 1.11 W/kg

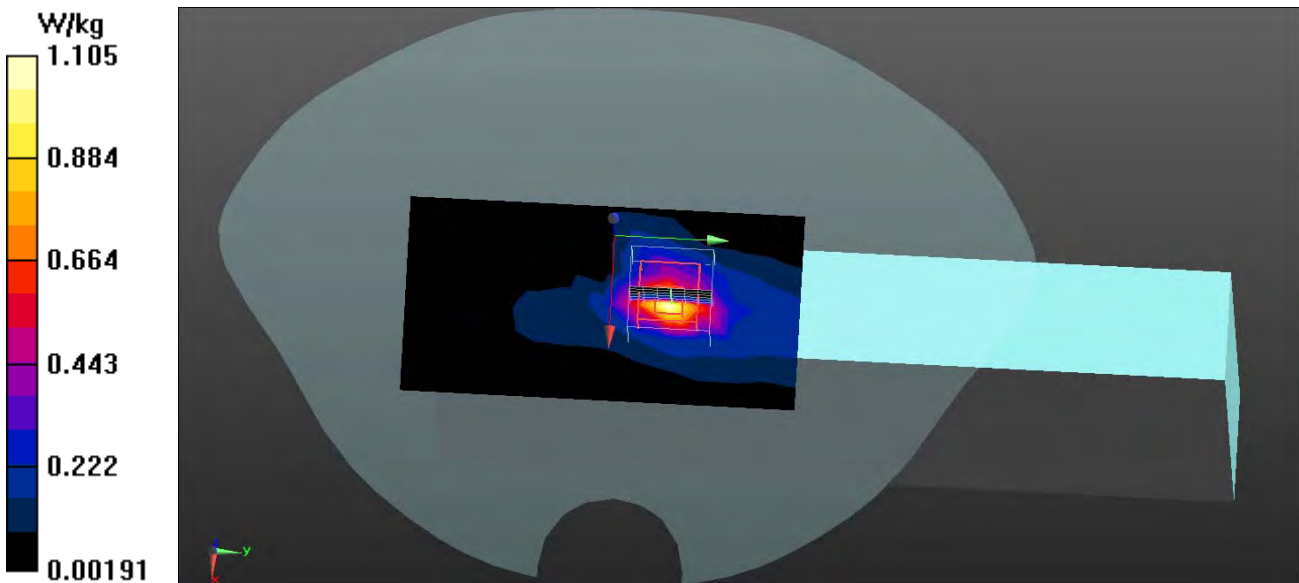

802.11g Aux Antenna EUT Top, Z-Axis plot
Channel: 1

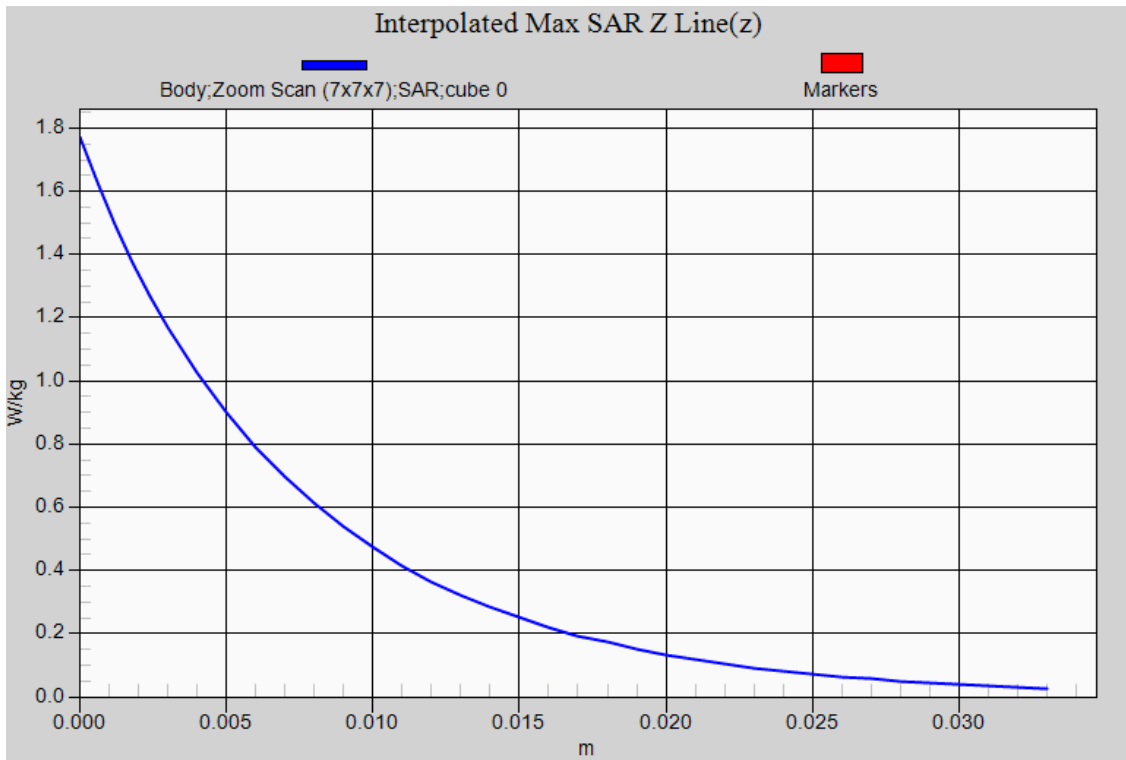

Antenna Kit : MilDef Crete Inc. Main Antenna, P/N: DK10 Main Antenna

Test Laboratory: QuieTek

Date/Time: 7/27/2013

802.11a_5745-Top TX1

DUT: Handheld Computer; Type: DK10

Communication System: WLAN 5G; Frequency: 5745 MHz;

Communication System PAR: 0 dB

Medium parameters used: $f = 5745 \text{ MHz}$; $\sigma = 6.21 \text{ S/m}$; $\epsilon_r = 46.65$; $\rho = 1000 \text{ kg/m}^3$

Phantom section: Flat Section

Ambient Temperature (°C) : 22.8, Liquid Temperature (°C) : 21.1

Measurement Standard: DASYS (IEEE/IEC/ANSI C63.19-2007)

DASY5 Configuration:

- Probe: EX3DV4 - SN3661; ConvF(3.97, 3.97, 3.97); Calibrated: 1/15/2013;
- Sensor-Surface: 1.4mm (Mechanical Surface Detection)
- Electronics: DAE4 Sn1207; Calibrated: 5/22/2013
- Phantom: SAM with right table; Type: SAM;
- Measurement SW: DASY52, Version 52.8 (5); SEMCAD X Version 14.6.8 (7028)

Configuration/Body/Area Scan (8x16x1): Measurement grid: dx=10mm, dy=10mm

Maximum value of SAR (measured) = 2.63 W/kg

Configuration/Body/Zoom Scan (7x7x12) (7x7x12)/Cube 0: Measurement grid:

dx=4mm, dy=4mm, dz=2mm

Reference Value = 10.177 V/m; Power Drift = 0.01 dB

Peak SAR (extrapolated) = 5.68 W/kg

SAR(1 g) = 1.19 W/kg; SAR(10 g) = 0.364 W/kg

Maximum value of SAR (measured) = 3.39 W/kg

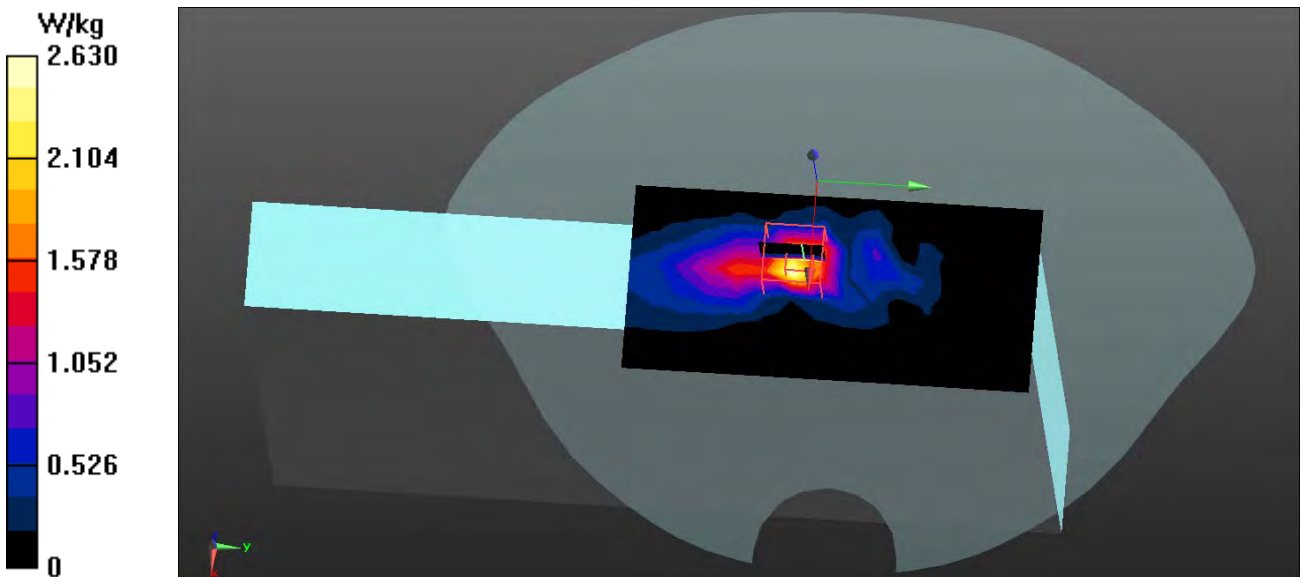

Test Laboratory: QuieTek

Date/Time: 7/27/2013

802.11a_5785-Top TX1

DUT: Handheld Computer; Type: DK10

Communication System: WLAN 5G; Frequency: 5785 MHz;

Communication System PAR: 0 dB

Medium parameters used: $f = 5785$ MHz; $\sigma = 6.24$ S/m; $\epsilon_r = 46.24$; $\rho = 1000$ kg/m³

Phantom section: Flat Section

Ambient Temperature (°C) : 22.8, Liquid Temperature (°C) : 21.1

Measurement Standard: DASYS (IEEE/IEC/ANSI C63.19-2007)

DASY5 Configuration:

- Probe: EX3DV4 - SN3661; ConvF(3.97, 3.97, 3.97); Calibrated: 1/15/2013;
- Sensor-Surface: 1.4mm (Mechanical Surface Detection)
- Electronics: DAE4 Sn1207; Calibrated: 5/22/2013
- Phantom: SAM with right table; Type: SAM;
- Measurement SW: DASY52, Version 52.8 (5); SEMCAD X Version 14.6.8 (7028)

Configuration/Body/Area Scan (8x9x1): Measurement grid: dx=10mm, dy=10mm

Maximum value of SAR (measured) = 2.35 W/kg

Configuration/Body/Zoom Scan (7x7x12) (7x7x12)/Cube 0: Measurement grid:

dx=4mm, dy=4mm, dz=2mm

Reference Value = 9.158 V/m; Power Drift = -0.32 dB

Peak SAR (extrapolated) = 5.16 W/kg

SAR(1 g) = 1.12 W/kg; SAR(10 g) = 0.341 W/kg

Maximum value of SAR (measured) = 3.08 W/kg

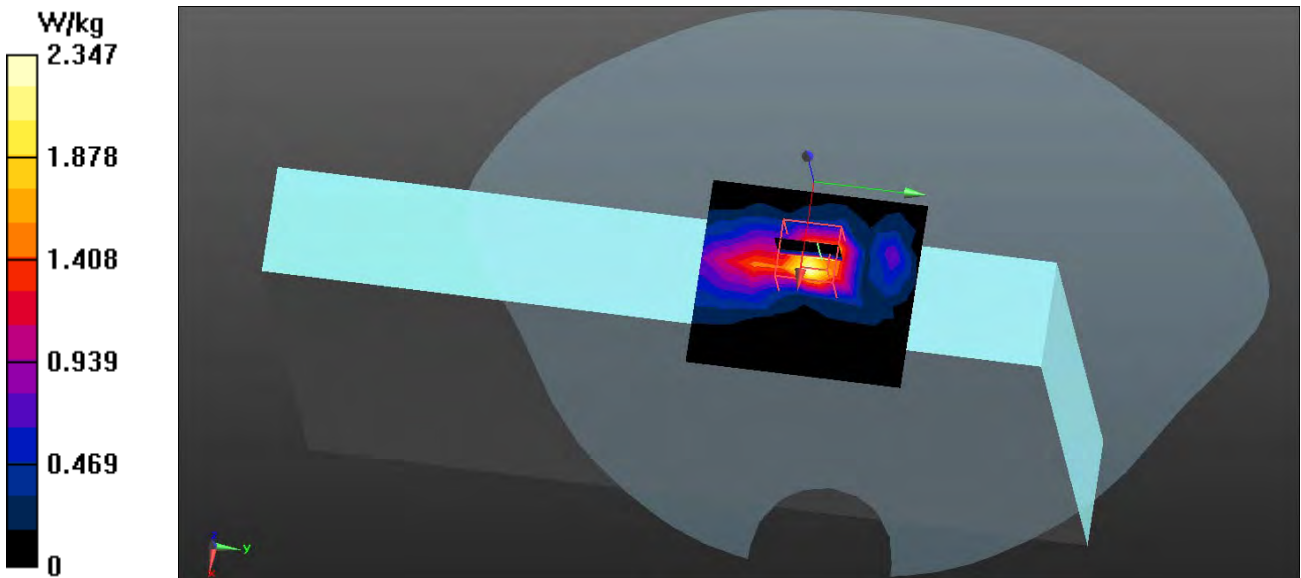

Test Laboratory: QuieTek

Date/Time: 7/27/2013

802.11a_5825-Top TX1

DUT: Handheld Computer; Type: DK10

Communication System: WLAN 5G; Frequency: 5825 MHz;

Communication System PAR: 0 dB

Medium parameters used: $f = 5825 \text{ MHz}$; $\sigma = 6.28 \text{ S/m}$; $\epsilon_r = 46.03$; $\rho = 1000 \text{ kg/m}^3$

Phantom section: Flat Section

Ambient Temperature (°C) : 22.8, Liquid Temperature (°C) : 21.1

Measurement Standard: DASYS (IEEE/IEC/ANSI C63.19-2007)

DASY5 Configuration:

- Probe: EX3DV4 - SN3661; ConvF(3.97, 3.97, 3.97); Calibrated: 1/15/2013;
- Sensor-Surface: 1.4mm (Mechanical Surface Detection)
- Electronics: DAE4 Sn1207; Calibrated: 5/22/2013
- Phantom: SAM with right table; Type: SAM;
- Measurement SW: DASY52, Version 52.8 (5); SEMCAD X Version 14.6.8 (7028)

Configuration/Body/Area Scan (8x9x1): Measurement grid: $dx=10\text{mm}$, $dy=10\text{mm}$

Maximum value of SAR (measured) = 1.74 W/kg

Configuration/Body/Zoom Scan (7x7x12) (7x7x12)/Cube 0: Measurement grid:

$dx=4\text{mm}$, $dy=4\text{mm}$, $dz=2\text{mm}$

Reference Value = 7.689 V/m; Power Drift = -0.18 dB

Peak SAR (extrapolated) = 3.75 W/kg

SAR(1 g) = 0.881 W/kg; SAR(10 g) = 0.249 W/kg

Maximum value of SAR (measured) = 2.19 W/kg

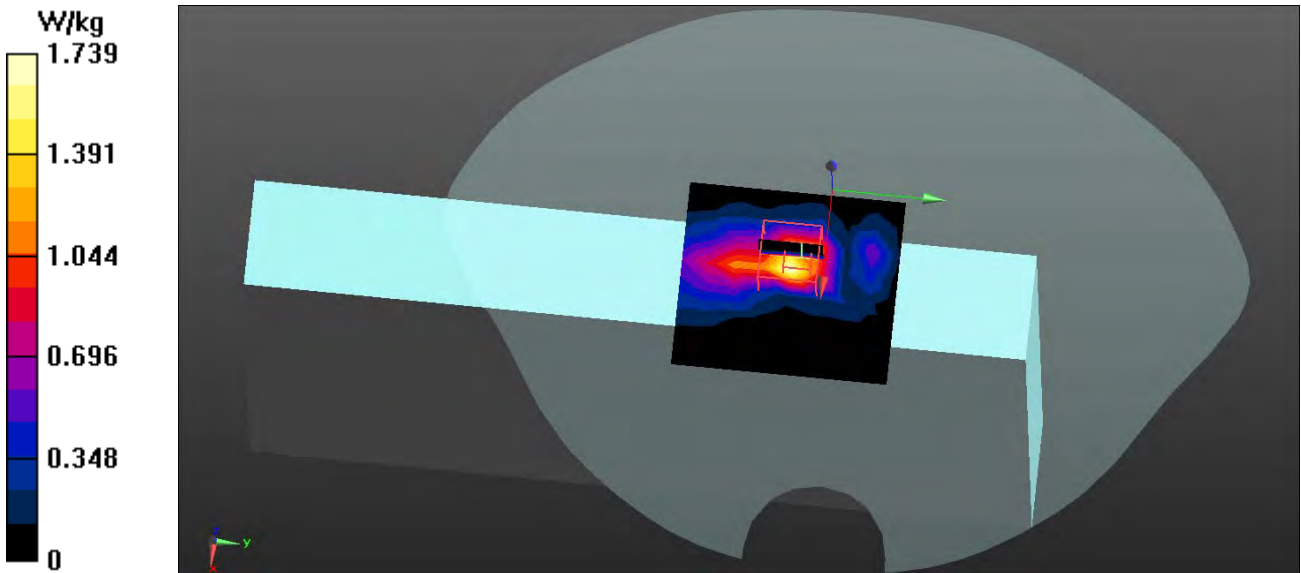

Test Laboratory: QuieTek

Date/Time: 7/27/2013

802.11a_5785-Back TX1

DUT: Handheld Computer; Type: DK10

Communication System: WLAN 5G; Frequency: 5785 MHz;

Communication System PAR: 0 dB

Medium parameters used: $f = 5785$ MHz; $\sigma = 6.24$ S/m; $\epsilon_r = 46.24$; $\rho = 1000$ kg/m³

Phantom section: Flat Section

Ambient Temperature (°C) : 22.8, Liquid Temperature (°C) : 21.1

Measurement Standard: DASYS (IEEE/IEC/ANSI C63.19-2007)

DASY5 Configuration:

- Probe: EX3DV4 - SN3661; ConvF(3.97, 3.97, 3.97); Calibrated: 1/15/2013;
- Sensor-Surface: 1.4mm (Mechanical Surface Detection)
- Electronics: DAE4 Sn1207; Calibrated: 5/22/2013
- Phantom: SAM with right table; Type: SAM;
- Measurement SW: DASY52, Version 52.8 (5); SEMCAD X Version 14.6.8 (7028)

Configuration/Body/Area Scan (7x11x1): Measurement grid: dx=12mm, dy=12mm
 Maximum value of SAR (measured) = 1.27 W/kg

Configuration/Body/Zoom Scan (7x7x12) (7x7x12)/Cube 0: Measurement grid:
 dx=4mm, dy=4mm, dz=2mm

Reference Value = 5.611 V/m; Power Drift = 0.15 dB

Peak SAR (extrapolated) = 2.67 W/kg

SAR(1 g) = 0.672 W/kg; SAR(10 g) = 0.211 W/kg

Maximum value of SAR (measured) = 1.62 W/kg

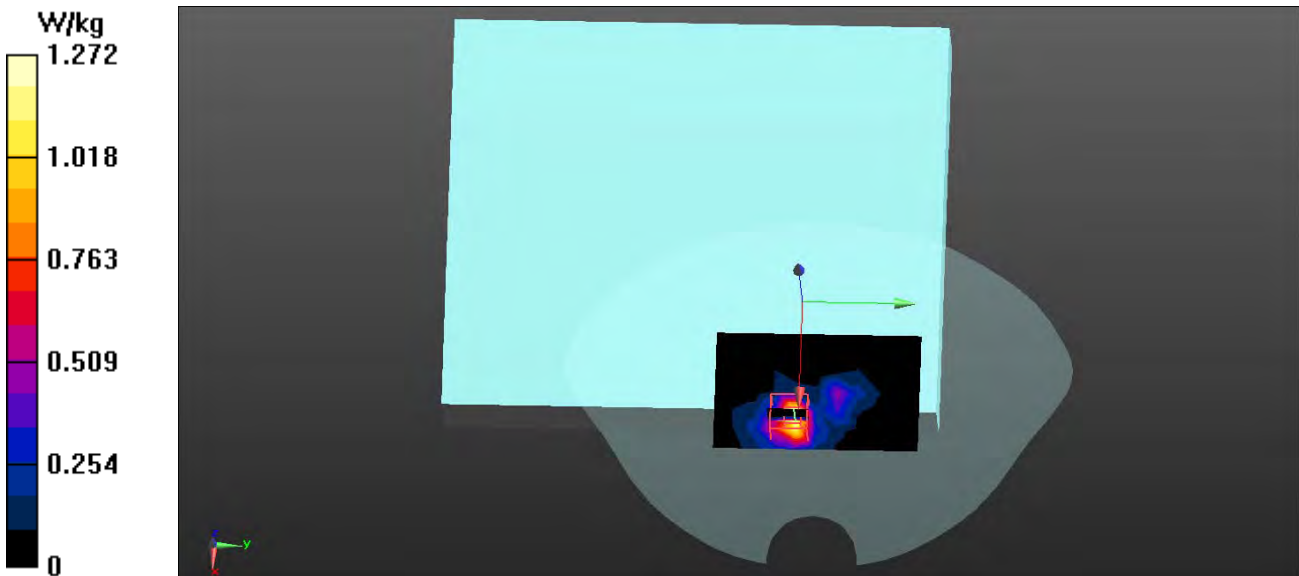

Test Laboratory: Quietek

Date/Time: 7/27/2013

802.11a_5785-Right-Side TX1

DUT: Handheld Computer; Type: DK10

Communication System: WLAN 5G; Frequency: 5785 MHz;

Communication System PAR: 0 dB

Medium parameters used: $f = 5785$ MHz; $\sigma = 6.24$ S/m; $\epsilon_r = 46.24$; $\rho = 1000$ kg/m³

Phantom section: Flat Section

Ambient Temperature (°C) : 22.8, Liquid Temperature (°C) : 21.1

Measurement Standard: DASYS (IEEE/IEC/ANSI C63.19-2007)

DASY5 Configuration:

- Probe: EX3DV4 - SN3661; ConvF(3.97, 3.97, 3.97); Calibrated: 1/15/2013;
- Sensor-Surface: 1.4mm (Mechanical Surface Detection)
- Electronics: DAE4 Sn1207; Calibrated: 5/22/2013
- Phantom: SAM with right table; Type: SAM;
- Measurement SW: DASY52, Version 52.8 (5); SEMCAD X Version 14.6.8 (7028)

Configuration/Body/Area Scan (9x9x1): Measurement grid: dx=12mm, dy=12mm

Maximum value of SAR (measured) = 0.0492 W/kg

Configuration/Body/Zoom Scan (7x7x12) (7x7x12)/Cube 0: Measurement grid:

dx=4mm, dy=4mm, dz=2mm

Reference Value = 0.511 V/m; Power Drift = 0.11 dB

Peak SAR (extrapolated) = 0.0740 W/kg

SAR(1 g) = 0.017 W/kg; SAR(10 g) = 0.00689 W/kg

Maximum value of SAR (measured) = 0.0467 W/kg

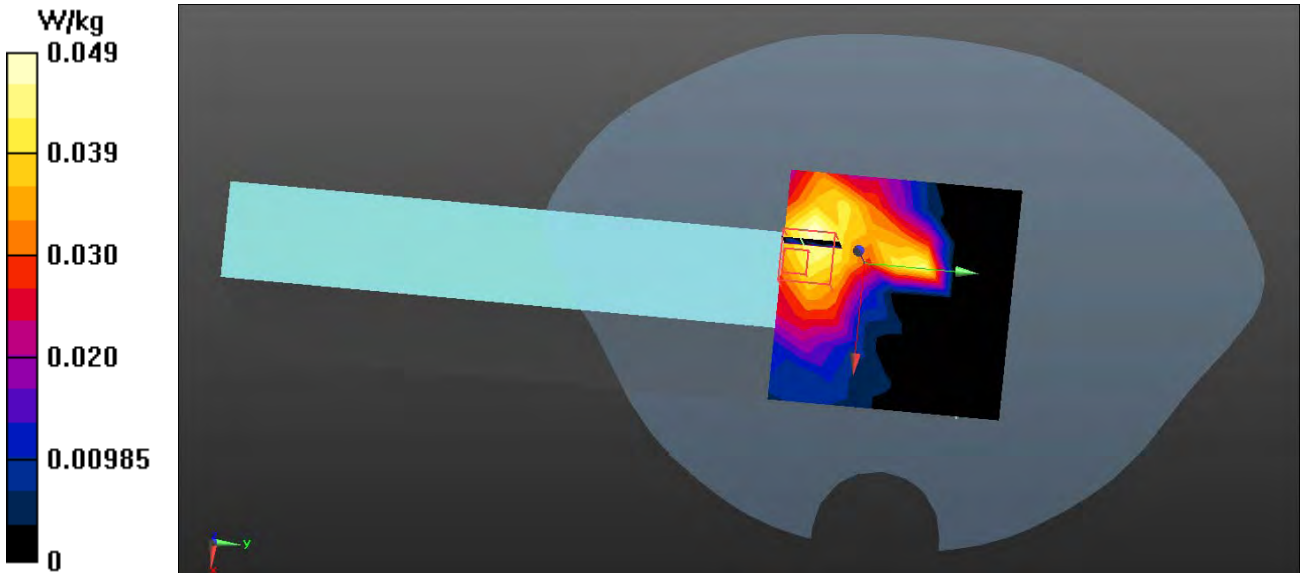

Antenna Kit : MilDef Crete Inc. Aux Antenna, P/N: DK10 Aux Antenna

Test Laboratory: QuieTek

Date/Time: 7/27/2013

802.11a_5745-Top TX2

DUT: Handheld Computer; Type: DK10

Communication System: WLAN 5G; Frequency: 5745 MHz;

Communication System PAR: 0 dB

Medium parameters used: $f = 5745 \text{ MHz}$; $\sigma = 6.21 \text{ S/m}$; $\epsilon_r = 46.65$; $\rho = 1000 \text{ kg/m}^3$

Phantom section: Flat Section

Ambient Temperature (°C) : 22.8, Liquid Temperature (°C) : 21.1

Measurement Standard: DASYS (IEEE/IEC/ANSI C63.19-2007)

DASY5 Configuration:

- Probe: EX3DV4 - SN3661; ConvF(3.97, 3.97, 3.97); Calibrated: 1/15/2013;
- Sensor-Surface: 1.4mm (Mechanical Surface Detection)
- Electronics: DAE4 Sn1207; Calibrated: 5/22/2013
- Phantom: SAM with right table; Type: SAM;
- Measurement SW: DASY52, Version 52.8 (5); SEMCAD X Version 14.6.8 (7028)

Configuration/Body/Area Scan (7x9x1): Measurement grid: dx=12mm, dy=12mm

Maximum value of SAR (measured) = 2.90 W/kg

Configuration/Body/Zoom Scan (7x7x12) (7x7x12)/Cube 0: Measurement grid:

dx=4mm, dy=4mm, dz=2mm

Reference Value = 14.875 V/m; Power Drift = -0.14 dB

Peak SAR (extrapolated) = 4.89 W/kg

SAR(1 g) = 1.12 W/kg; SAR(10 g) = 0.292 W/kg

Maximum value of SAR (measured) = 2.92 W/kg

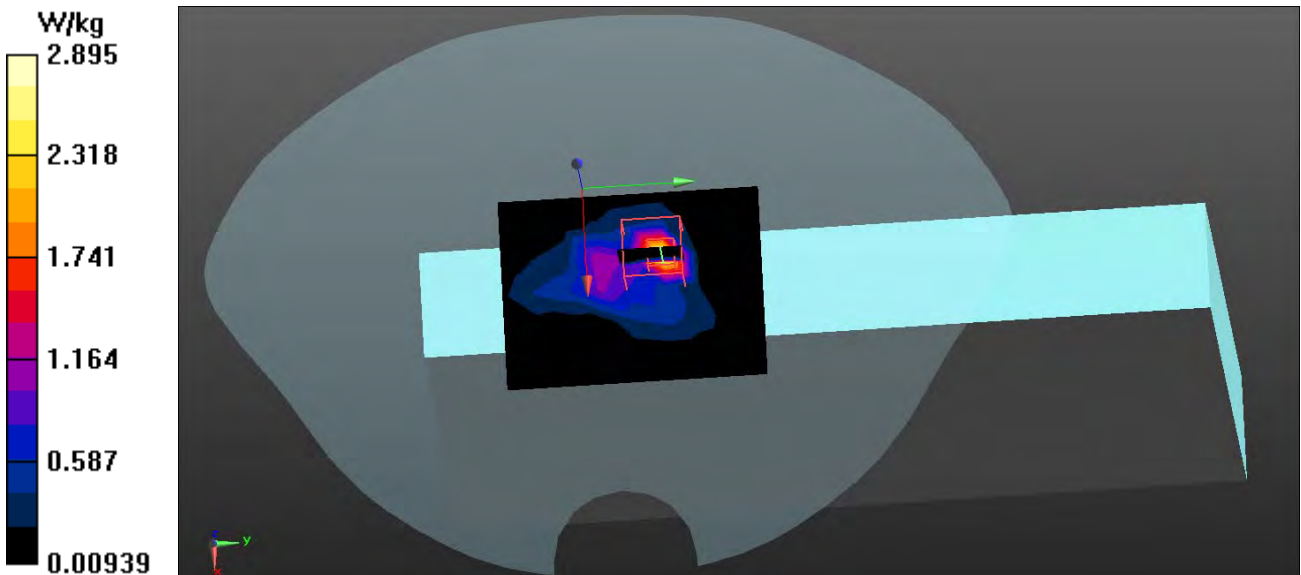

Test Laboratory: QuieTek

Date/Time: 7/27/2013

802.11a_5785-Top TX2

DUT: Handheld Computer; Type: DK10

Communication System: WLAN 5G; Frequency: 5785 MHz;

Communication System PAR: 0 dB

Medium parameters used: $f = 5785 \text{ MHz}$; $\sigma = 6.24 \text{ S/m}$; $\epsilon_r = 46.24$; $\rho = 1000 \text{ kg/m}^3$

Phantom section: Flat Section

Ambient Temperature (°C) : 22.8, Liquid Temperature (°C) : 21.1

Measurement Standard: DASYS (IEEE/IEC/ANSI C63.19-2007)

DASY5 Configuration:

- Probe: EX3DV4 - SN3661; ConvF(3.97, 3.97, 3.97); Calibrated: 1/15/2013;
- Sensor-Surface: 1.4mm (Mechanical Surface Detection)
- Electronics: DAE4 Sn1207; Calibrated: 5/22/2013
- Phantom: SAM with right table; Type: SAM;
- Measurement SW: DASY52, Version 52.8 (5); SEMCAD X Version 14.6.8 (7028)

Configuration/Body/Area Scan (7x9x1): Measurement grid: dx=12mm, dy=12mm

Maximum value of SAR (measured) = 2.98 W/kg

Configuration/Body/Zoom Scan (7x7x12) (7x7x12)/Cube 0: Measurement grid:

dx=4mm, dy=4mm, dz=2mm

Reference Value = 15.760 V/m; Power Drift = -0.11 dB

Peak SAR (extrapolated) = 5.40 W/kg

SAR(1 g) = 1.18 W/kg; SAR(10 g) = 0.324 W/kg

Maximum value of SAR (measured) = 3.23 W/kg

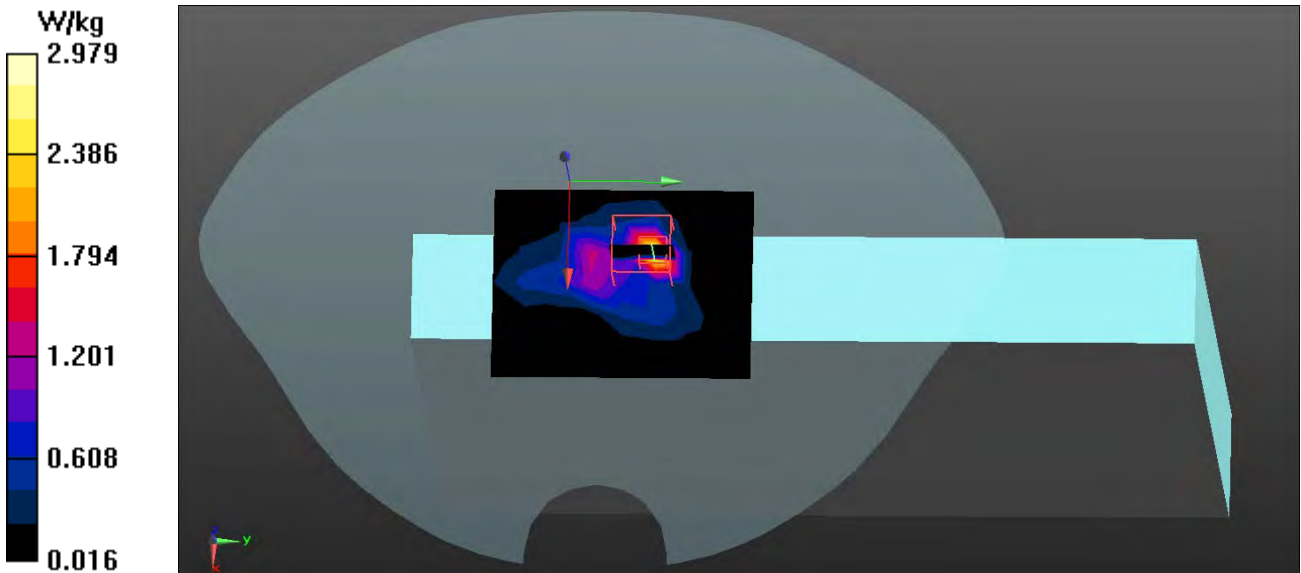

Test Laboratory: QuieTek

Date/Time: 7/27/2013

802.11a_5825-Top TX2

DUT: Handheld Computer; Type: DK10

Communication System: WLAN 5G; Frequency: 5825 MHz;

Communication System PAR: 0 dB

Medium parameters used: $f = 5825 \text{ MHz}$; $\sigma = 6.28 \text{ S/m}$; $\epsilon_r = 46.03$; $\rho = 1000 \text{ kg/m}^3$

Phantom section: Flat Section

Ambient Temperature (°C) : 22.8, Liquid Temperature (°C) : 21.1

Measurement Standard: DASYS (IEEE/IEC/ANSI C63.19-2007)

DASY5 Configuration:

- Probe: EX3DV4 - SN3661; ConvF(3.97, 3.97, 3.97); Calibrated: 1/15/2013;
- Sensor-Surface: 1.4mm (Mechanical Surface Detection)
- Electronics: DAE4 Sn1207; Calibrated: 5/22/2013
- Phantom: SAM with right table; Type: SAM;
- Measurement SW: DASY52, Version 52.8 (5); SEMCAD X Version 14.6.8 (7028)

Configuration/Body/Area Scan (7x9x1): Measurement grid: dx=12mm, dy=12mm

Maximum value of SAR (measured) = 2.82 W/kg

Configuration/Body/Zoom Scan (7x7x12) (7x7x12)/Cube 0: Measurement grid:

dx=4mm, dy=4mm, dz=2mm

Reference Value = 15.642 V/m; Power Drift = -0.14 dB

Peak SAR (extrapolated) = 4.79 W/kg

SAR(1 g) = 1.07 W/kg; SAR(10 g) = 0.279 W/kg

Maximum value of SAR (measured) = 2.81 W/kg

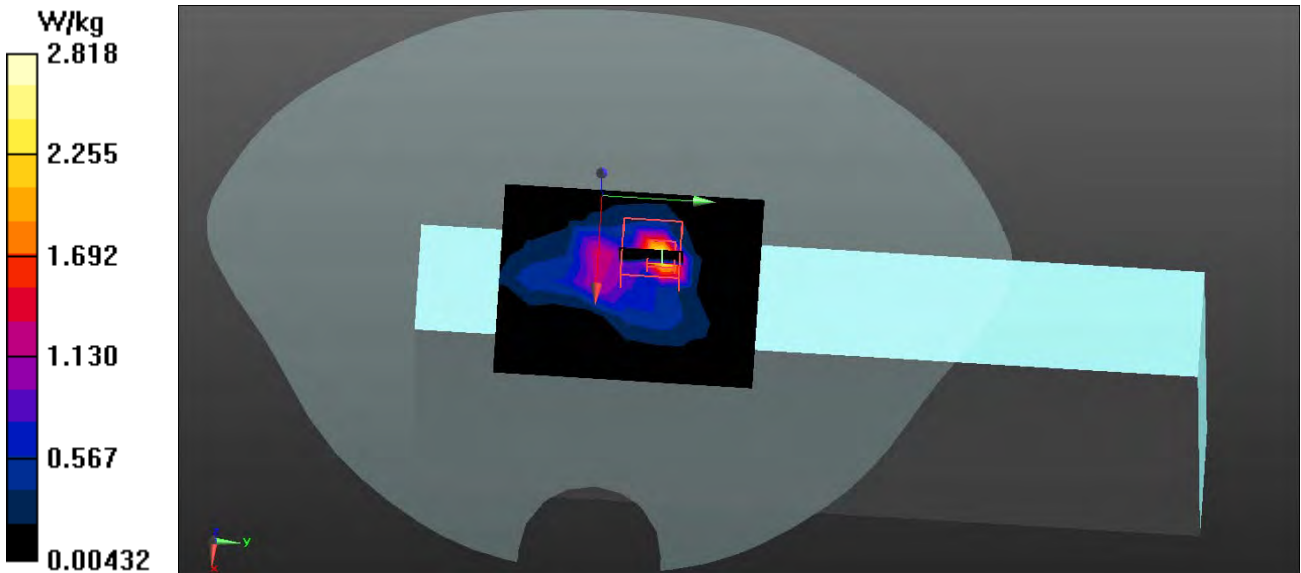

Test Laboratory: QuieTek

Date/Time: 7/27/2013

802.11a_5785-Back TX2

DUT: Handheld Computer; Type: DK10

Communication System: WLAN 5G; Frequency: 5785 MHz;

Communication System PAR: 0 dB

Medium parameters used: $f = 5785 \text{ MHz}$; $\sigma = 6.24 \text{ S/m}$; $\epsilon_r = 46.24$; $\rho = 1000 \text{ kg/m}^3$

Phantom section: Flat Section

Ambient Temperature (°C) : 22.8, Liquid Temperature (°C) : 21.1

Measurement Standard: DASYS (IEEE/IEC/ANSI C63.19-2007)

DASY5 Configuration:

- Probe: EX3DV4 - SN3661; ConvF(3.97, 3.97, 3.97); Calibrated: 1/15/2013;
- Sensor-Surface: 1.4mm (Mechanical Surface Detection)
- Electronics: DAE4 Sn1207; Calibrated: 5/22/2013
- Phantom: SAM with right table; Type: SAM;
- Measurement SW: DASY52, Version 52.8 (5); SEMCAD X Version 14.6.8 (7028)

Configuration/Body/Area Scan (7x11x1): Measurement grid: $dx=12\text{mm}$, $dy=12\text{mm}$
 Maximum value of SAR (measured) = 0.713 W/kg

Configuration/Body/Zoom Scan (7x7x12) (7x7x12)/Cube 0: Measurement grid:
 $dx=4\text{mm}$, $dy=4\text{mm}$, $dz=2\text{mm}$

Reference Value = 7.712 V/m; Power Drift = -0.17 dB

Peak SAR (extrapolated) = 1.30 W/kg

SAR(1 g) = 0.358 W/kg; SAR(10 g) = 0.122 W/kg

Maximum value of SAR (measured) = 0.834 W/kg

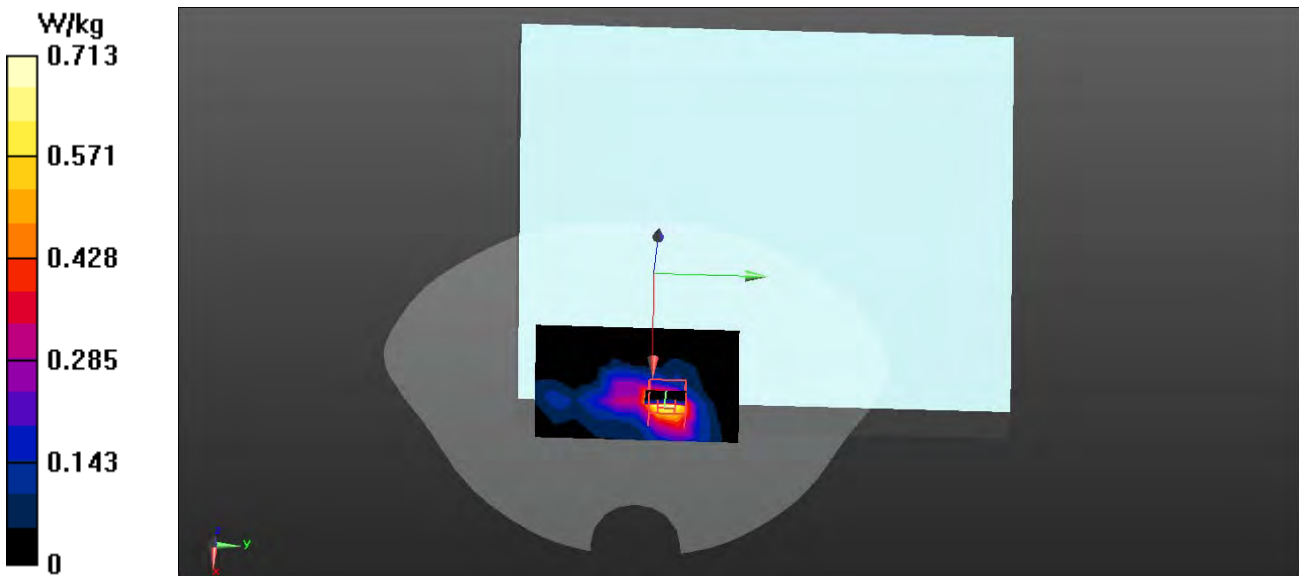

Test Laboratory: QuieTek

Date/Time: 7/27/2013

802.11a_5785-Left-Side TX2

DUT: Handheld Computer; Type: DK10

Communication System: WLAN 5G; Frequency: 5785 MHz;

Communication System PAR: 0 dB

Medium parameters used: $f = 5785 \text{ MHz}$; $\sigma = 6.24 \text{ S/m}$; $\epsilon_r = 46.24$; $\rho = 1000 \text{ kg/m}^3$

Phantom section: Flat Section

Ambient Temperature (°C) : 22.8, Liquid Temperature (°C) : 21.1

Measurement Standard: DASYS (IEEE/IEC/ANSI C63.19-2007)

DASY5 Configuration:

- Probe: EX3DV4 - SN3661; ConvF(3.97, 3.97, 3.97); Calibrated: 1/15/2013;
- Sensor-Surface: 1.4mm (Mechanical Surface Detection)
- Electronics: DAE4 Sn1207; Calibrated: 5/22/2013
- Phantom: SAM with right table; Type: SAM;
- Measurement SW: DASY52, Version 52.8 (5); SEMCAD X Version 14.6.8 (7028)

Configuration/Body/Area Scan (9x9x1): Measurement grid: $dx=12\text{mm}$, $dy=12\text{mm}$

Maximum value of SAR (measured) = 0.0442 W/kg

Configuration/Body/Zoom Scan (7x7x12) (7x7x12)/Cube 0: Measurement grid:

$dx=4\text{mm}$, $dy=4\text{mm}$, $dz=2\text{mm}$

Reference Value = 1.478 V/m; Power Drift = -0.15 dB

Peak SAR (extrapolated) = 0.126 W/kg

SAR(1 g) = 0.012 W/kg; SAR(10 g) = 0.00483 W/kg

Maximum value of SAR (measured) = 0.0356 W/kg

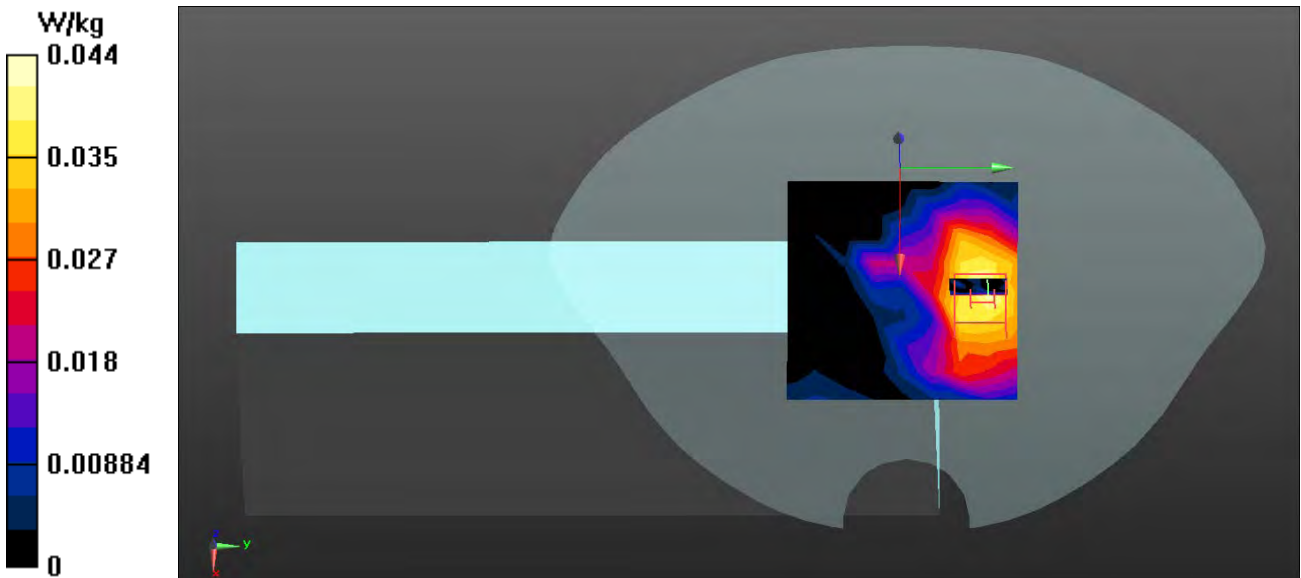

Antenna Kit : MilDef Crete Inc. Main Antenna, P/N: DK10 Main Antenna

Test Laboratory: QuieTek

Date/Time: 7/27/2013

802.11n-20M_5745-Top TX1

DUT: Handheld Computer; Type: DK10

Communication System: WLAN 5G; Frequency: 5745 MHz;

Communication System PAR: 0 dB

Medium parameters used: $f = 5745 \text{ MHz}$; $\sigma = 6.21 \text{ S/m}$; $\epsilon_r = 46.65$; $\rho = 1000 \text{ kg/m}^3$

Phantom section: Flat Section

Ambient Temperature (°C) : 22.8, Liquid Temperature (°C) : 21.1

Measurement Standard: DASYS (IEEE/IEC/ANSI C63.19-2007)

DASY5 Configuration:

- Probe: EX3DV4 - SN3661; ConvF(3.97, 3.97, 3.97); Calibrated: 1/15/2013;
- Sensor-Surface: 1.4mm (Mechanical Surface Detection)
- Electronics: DAE4 Sn1207; Calibrated: 5/22/2013
- Phantom: SAM with right table; Type: SAM;
- Measurement SW: DASY52, Version 52.8 (5); SEMCAD X Version 14.6.8 (7028)

Configuration/Body/Area Scan (7x9x1): Measurement grid: dx=12mm, dy=12mm

Maximum value of SAR (measured) = 2.93 W/kg

Configuration/Body/Zoom Scan (7x7x12) (7x7x12)/Cube 0: Measurement grid:

dx=4mm, dy=4mm, dz=2mm

Reference Value = 8.621 V/m; Power Drift = -0.12 dB

Peak SAR (extrapolated) = 4.93 W/kg

SAR(1 g) = 1.16 W/kg; SAR(10 g) = 0.309 W/kg

Maximum value of SAR (measured) = 3.02 W/kg

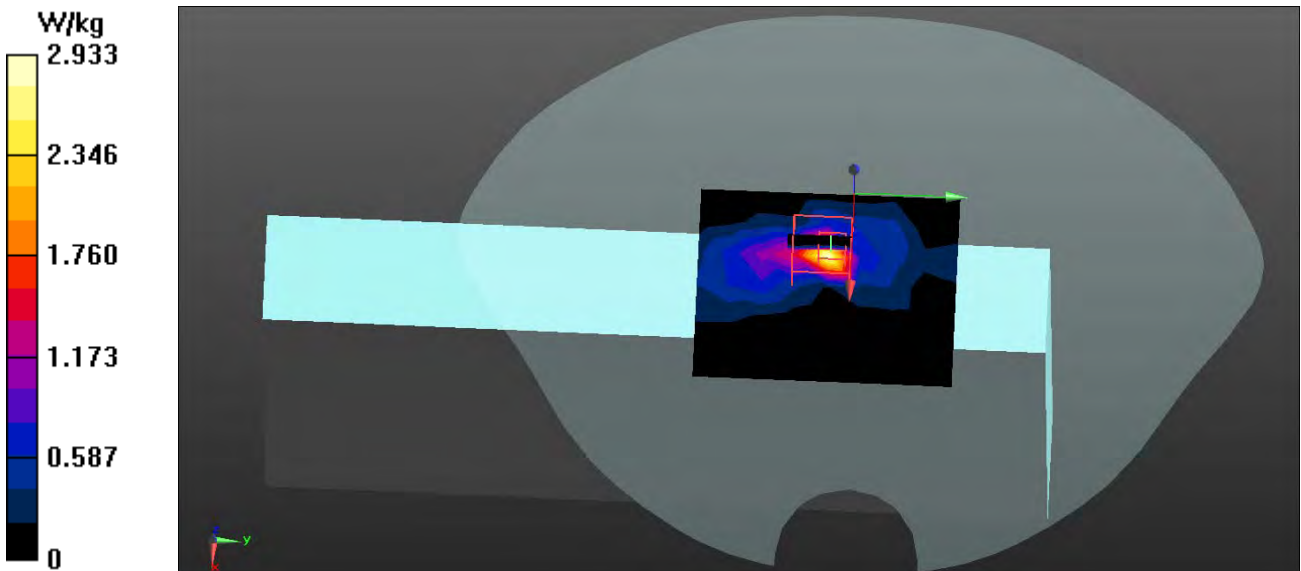

Test Laboratory: QuieTek

Date/Time: 7/27/2013

802.11n-20M_5785-Top TX1

DUT: Handheld Computer; Type: DK10

Communication System: WLAN 5G; Frequency: 5785 MHz;

Communication System PAR: 0 dB

Medium parameters used: $f = 5785$ MHz; $\sigma = 6.24$ S/m; $\epsilon_r = 46.24$; $\rho = 1000$ kg/m³

Phantom section: Flat Section

Ambient Temperature (°C) : 22.8, Liquid Temperature (°C) : 21.1

Measurement Standard: DASYS (IEEE/IEC/ANSI C63.19-2007)

DASY5 Configuration:

- Probe: EX3DV4 - SN3661; ConvF(3.97, 3.97, 3.97); Calibrated: 1/15/2013;
- Sensor-Surface: 1.4mm (Mechanical Surface Detection)
- Electronics: DAE4 Sn1207; Calibrated: 5/22/2013
- Phantom: SAM with right table; Type: SAM;
- Measurement SW: DASY52, Version 52.8 (5); SEMCAD X Version 14.6.8 (7028)

Configuration/Body/Area Scan (7x9x1): Measurement grid: dx=12mm, dy=12mm

Maximum value of SAR (measured) = 2.92 W/kg

Configuration/Body/Zoom Scan (7x7x12) (7x7x12)/Cube 0: Measurement grid:

dx=4mm, dy=4mm, dz=2mm

Reference Value = 8.379 V/m; Power Drift = -0.04 dB

Peak SAR (extrapolated) = 4.90 W/kg

SAR(1 g) = 1.15 W/kg; SAR(10 g) = 0.311 W/kg

Maximum value of SAR (measured) = 2.94 W/kg

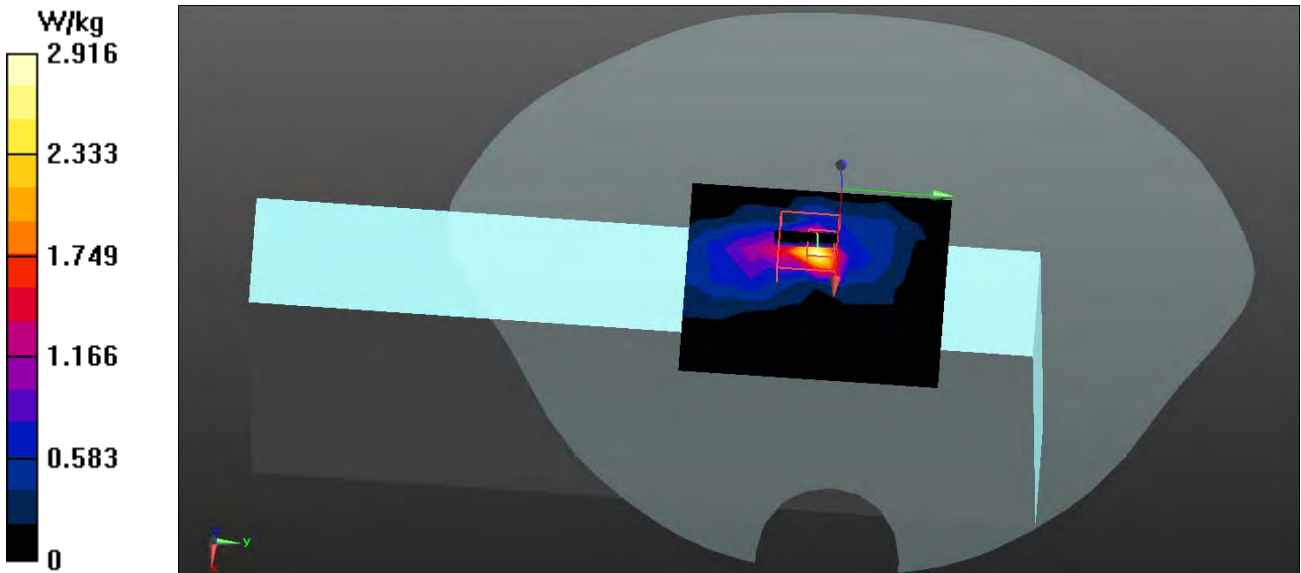

Test Laboratory: QuieTek

Date/Time: 7/27/2013

802.11n-20M_5825-Top TX1

DUT: Handheld Computer; Type: DK10

Communication System: WLAN 5G; Frequency: 5825 MHz;

Communication System PAR: 0 dB

Medium parameters used: $f = 5825$ MHz; $\sigma = 6.28$ S/m; $\epsilon_r = 46.03$; $\rho = 1000$ kg/m³

Phantom section: Flat Section

Ambient Temperature (°C) : 22.8, Liquid Temperature (°C) : 21.1

Measurement Standard: DASYS (IEEE/IEC/ANSI C63.19-2007)

DASY5 Configuration:

- Probe: EX3DV4 - SN3661; ConvF(3.97, 3.97, 3.97); Calibrated: 1/15/2013;
- Sensor-Surface: 1.4mm (Mechanical Surface Detection)
- Electronics: DAE4 Sn1207; Calibrated: 5/22/2013
- Phantom: SAM with right table; Type: SAM;
- Measurement SW: DASY52, Version 52.8 (5); SEMCAD X Version 14.6.8 (7028)

Configuration/Body/Area Scan (7x9x1): Measurement grid: dx=12mm, dy=12mm

Maximum value of SAR (measured) = 2.25 W/kg

Configuration/Body/Zoom Scan (7x7x12) (7x7x12)/Cube 0: Measurement grid:

dx=4mm, dy=4mm, dz=2mm

Reference Value = 7.387 V/m; Power Drift = -0.17 dB

Peak SAR (extrapolated) = 3.85 W/kg

SAR(1 g) = 0.892 W/kg; SAR(10 g) = 0.244 W/kg

Maximum value of SAR (measured) = 2.28 W/kg

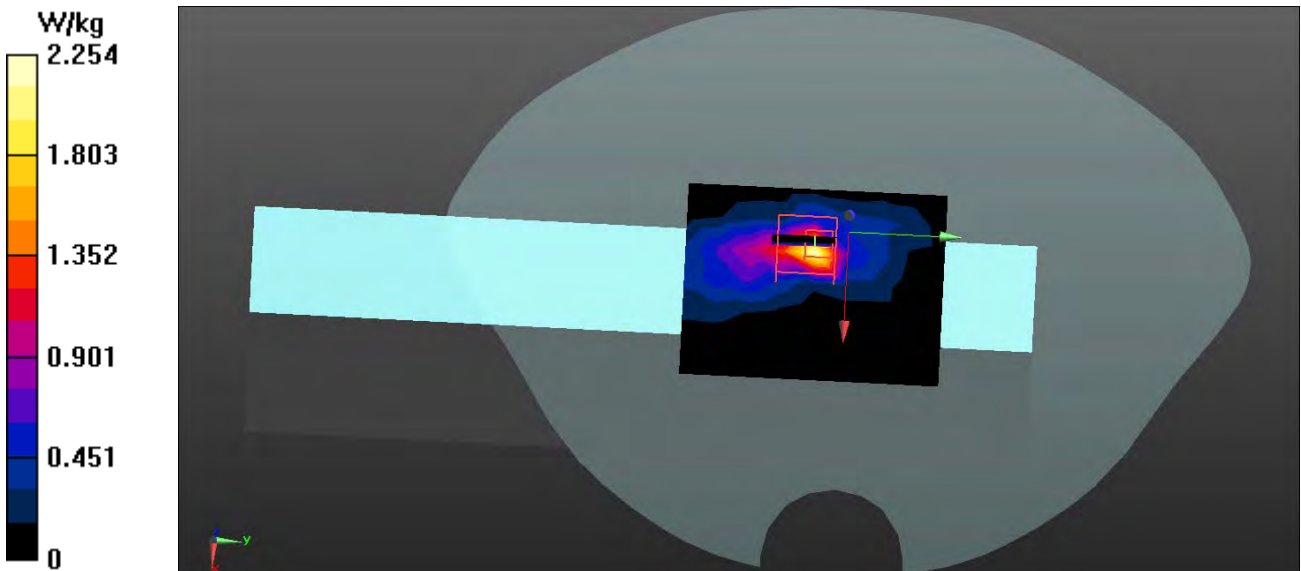

Antenna Kit : MilDef Crete Inc. Aux Antenna, P/N: DK10 Aux Antenna

Test Laboratory: QuieTek

Date/Time: 7/27/2013

802.11n-20M_5745-Top TX2

DUT: Handheld Computer; Type: DK10

Communication System: WLAN 5G; Frequency: 5745 MHz;

Communication System PAR: 0 dB

Medium parameters used: $f = 5745 \text{ MHz}$; $\sigma = 6.21 \text{ S/m}$; $\epsilon_r = 46.65$; $\rho = 1000 \text{ kg/m}^3$

Phantom section: Flat Section

Ambient Temperature (°C) : 22.8, Liquid Temperature (°C) : 21.1

Measurement Standard: DASY5 (IEEE/IEC/ANSI C63.19-2007)

DASY5 Configuration:

- Probe: EX3DV4 - SN3661; ConvF(3.97, 3.97, 3.97); Calibrated: 1/15/2013;
- Sensor-Surface: 1.4mm (Mechanical Surface Detection)
- Electronics: DAE4 Sn1207; Calibrated: 5/22/2013
- Phantom: SAM with right table; Type: SAM;
- Measurement SW: DASY52, Version 52.8 (5); SEMCAD X Version 14.6.8 (7028)

Configuration/Body/Area Scan (7x9x1): Measurement grid: dx=12mm, dy=12mm

Maximum value of SAR (measured) = 2.83 W/kg

Configuration/Body/Zoom Scan (7x7x12) (7x7x12)/Cube 0: Measurement grid:

dx=4mm, dy=4mm, dz=2mm

Reference Value = 14.735 V/m; Power Drift = -0.19 dB

Peak SAR (extrapolated) = 4.90 W/kg

SAR(1 g) = 0.99 W/kg; SAR(10 g) = 0.283 W/kg

Maximum value of SAR (measured) = 2.88 W/kg

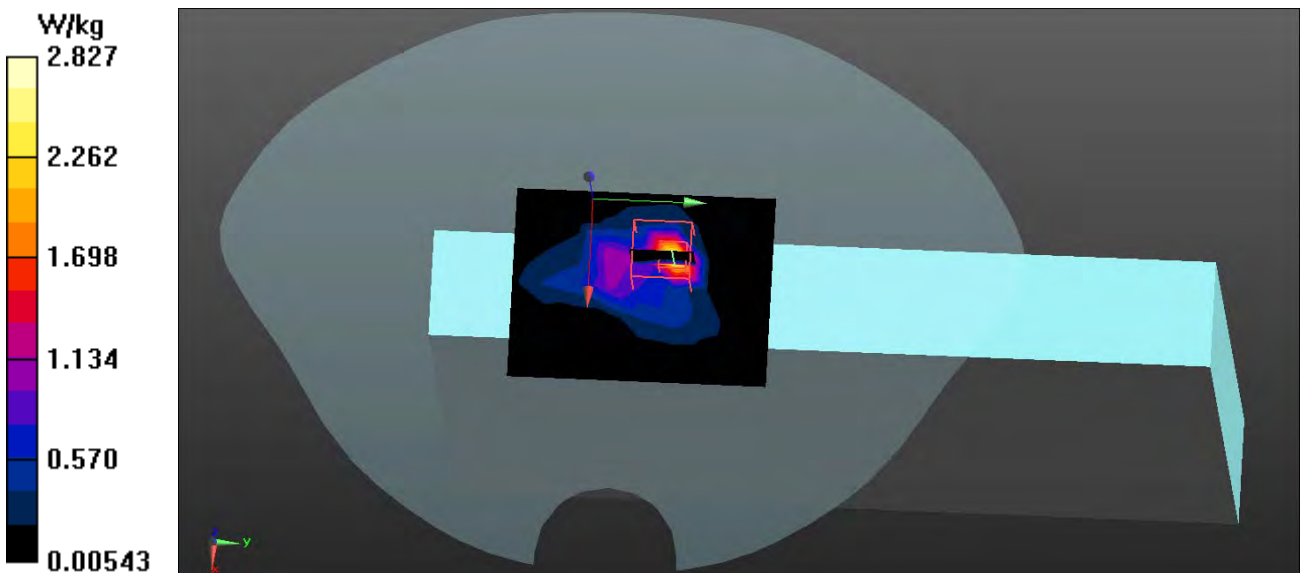

Test Laboratory: QuieTek

Date/Time: 7/27/2013

802.11n-20M_5785-Top TX2

DUT: Handheld Computer; Type: DK10

Communication System: WLAN 5G; Frequency: 5785 MHz;

Communication System PAR: 0 dB

Medium parameters used: $f = 5785$ MHz; $\sigma = 6.24$ S/m; $\epsilon_r = 46.24$; $\rho = 1000$ kg/m³

Phantom section: Flat Section

Ambient Temperature (°C) : 22.8, Liquid Temperature (°C) : 21.1

Measurement Standard: DASYS (IEEE/IEC/ANSI C63.19-2007)

DASY5 Configuration:

- Probe: EX3DV4 - SN3661; ConvF(3.97, 3.97, 3.97); Calibrated: 1/15/2013;
- Sensor-Surface: 1.4mm (Mechanical Surface Detection)
- Electronics: DAE4 Sn1207; Calibrated: 5/22/2013
- Phantom: SAM with right table; Type: SAM;
- Measurement SW: DASY52, Version 52.8 (5); SEMCAD X Version 14.6.8 (7028)

Configuration/Body/Area Scan (7x9x1): Measurement grid: dx=12mm, dy=12mm

Maximum value of SAR (measured) = 3.11 W/kg

Configuration/Body/Zoom Scan (7x7x12) (7x7x12)/Cube 0: Measurement grid:

dx=4mm, dy=4mm, dz=2mm

Reference Value = 17.024 V/m; Power Drift = -0.14 dB

Peak SAR (extrapolated) = 5.33 W/kg

SAR(1 g) = 1.09 W/kg; SAR(10 g) = 0.307 W/kg

Maximum value of SAR (measured) = 3.14 W/kg

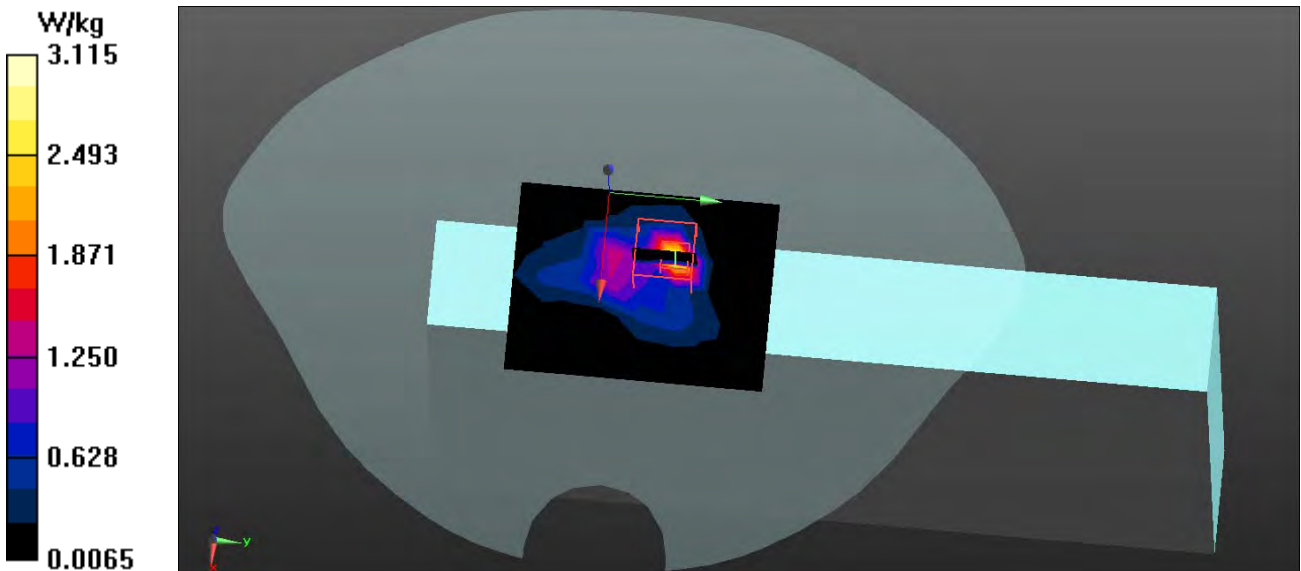

Test Laboratory: QuieTek

Date/Time: 7/27/2013

802.11n-20M_5825-Top TX2

DUT: Handheld Computer; Type: DK10

Communication System: WLAN 5G; Frequency: 5825 MHz;

Communication System PAR: 0 dB

Medium parameters used: $f = 5825 \text{ MHz}$; $\sigma = 6.28 \text{ S/m}$; $\epsilon_r = 46.03$; $\rho = 1000 \text{ kg/m}^3$

Phantom section: Flat Section

Ambient Temperature (°C) : 22.8, Liquid Temperature (°C) : 21.1

Measurement Standard: DASYS (IEEE/IEC/ANSI C63.19-2007)

DASY5 Configuration:

- Probe: EX3DV4 - SN3661; ConvF(3.97, 3.97, 3.97); Calibrated: 1/15/2013;
- Sensor-Surface: 1.4mm (Mechanical Surface Detection)
- Electronics: DAE4 Sn1207; Calibrated: 5/22/2013
- Phantom: SAM with right table; Type: SAM;
- Measurement SW: DASY52, Version 52.8 (5); SEMCAD X Version 14.6.8 (7028)

Configuration/Body/Area Scan (7x9x1): Measurement grid: dx=12mm, dy=12mm

Maximum value of SAR (measured) = 2.74 W/kg

Configuration/Body/Zoom Scan (7x7x12) (7x7x6)/Cube 0: Measurement grid:

dx=4mm, dy=4mm, dz=2mm

Reference Value = 15.515 V/m; Power Drift = -0.12 dB

Peak SAR (extrapolated) = 4.72 W/kg

SAR(1 g) = 0.95 W/kg; SAR(10 g) = 0.270 W/kg

Maximum value of SAR (measured) = 2.76 W/kg

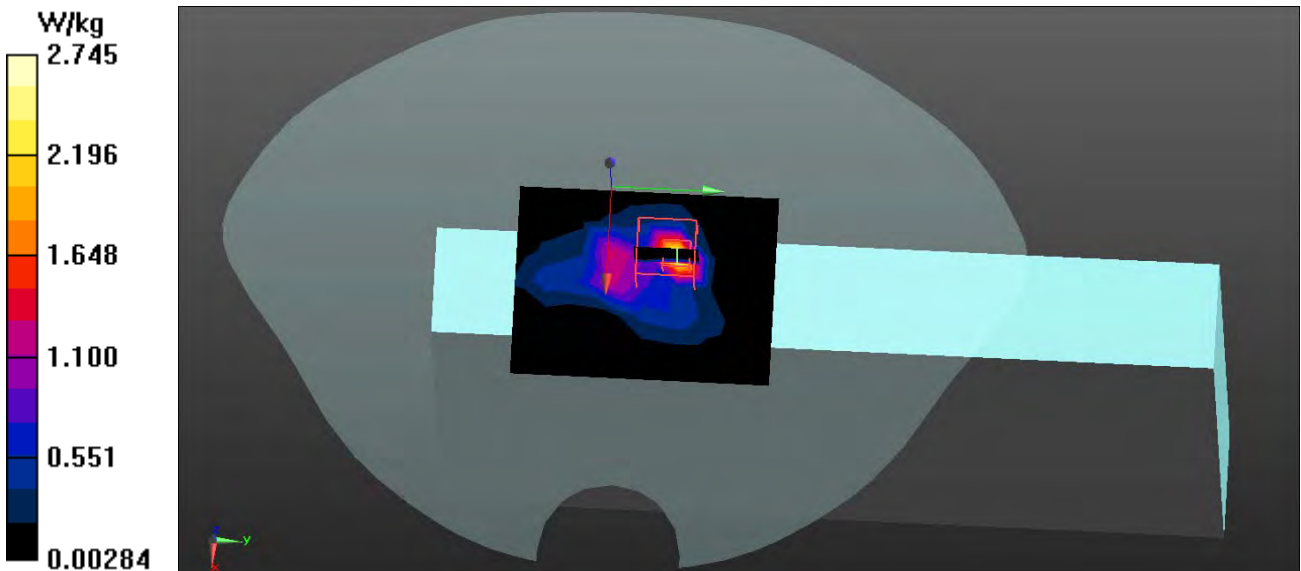

Antenna Kit : MilDef Crete Inc. Main Antenna, P/N: DK10 Main Antenna

Test Laboratory: QuieTek

Date/Time: 7/27/2013

802.11n-40M_5755-Top TX1

DUT: Handheld Computer; Type: DK10

Communication System: WLAN 5G; Frequency: 5755 MHz;

Communication System PAR: 0 dB

Medium parameters used: $f = 5755 \text{ MHz}$; $\sigma = 6.23 \text{ S/m}$; $\epsilon_r = 46.48$; $\rho = 1000 \text{ kg/m}^3$

Phantom section: Flat Section

Ambient Temperature (°C) : 22.8, Liquid Temperature (°C) : 21.1

Measurement Standard: DASYS (IEEE/IEC/ANSI C63.19-2007)

DASY5 Configuration:

- Probe: EX3DV4 - SN3661; ConvF(3.97, 3.97, 3.97); Calibrated: 1/15/2013;
- Sensor-Surface: 1.4mm (Mechanical Surface Detection)
- Electronics: DAE4 Sn1207; Calibrated: 5/22/2013
- Phantom: SAM with right table; Type: SAM;
- Measurement SW: DASY52, Version 52.8 (5); SEMCAD X Version 14.6.8 (7028)

Configuration/Body/Area Scan (7x9x1): Measurement grid: $dx=12\text{mm}$, $dy=12\text{mm}$

Maximum value of SAR (measured) = 2.75 W/kg

Configuration/Body/Zoom Scan (7x7x12) (7x7x12)/Cube 0: Measurement grid:

$dx=4\text{mm}$, $dy=4\text{mm}$, $dz=2\text{mm}$

Reference Value = 8.470 V/m; Power Drift = -0.11 dB

Peak SAR (extrapolated) = 4.61 W/kg

SAR(1 g) = 1.07 W/kg; SAR(10 g) = 0.282 W/kg

Maximum value of SAR (measured) = 2.74 W/kg

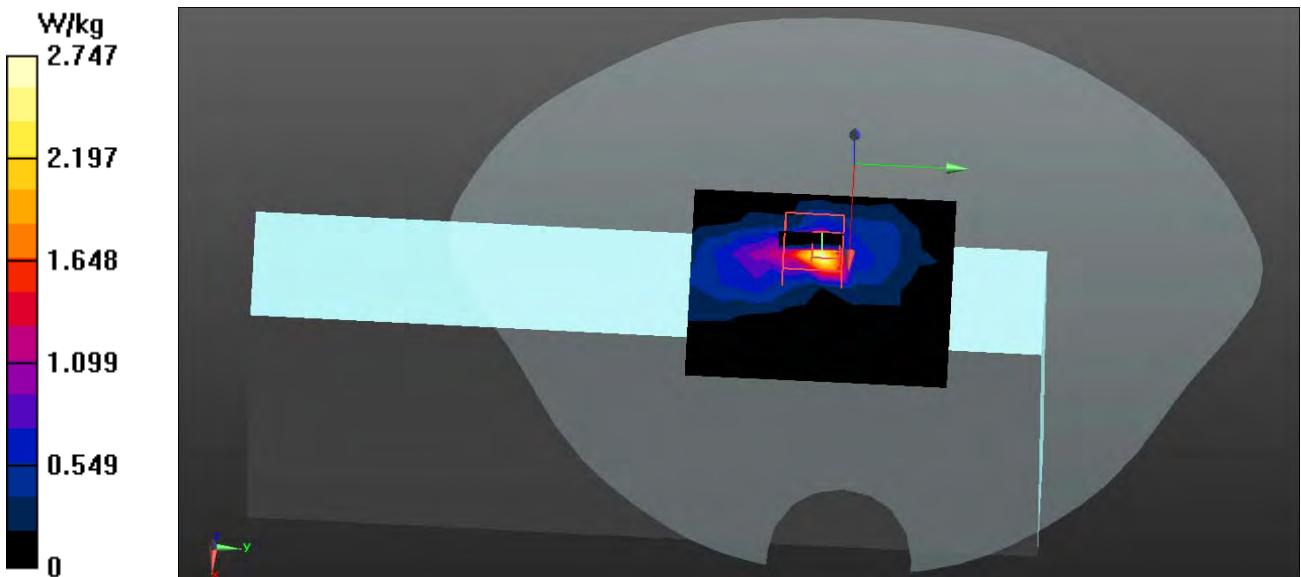

Test Laboratory: QuieTek

Date/Time: 7/27/2013

802.11n-40M_5795-Top TX1

DUT: Handheld Computer; Type: DK10

Communication System: WLAN 5G; Frequency: 5795 MHz;

Communication System PAR: 0 dB

Medium parameters used: $f = 5795$ MHz; $\sigma = 6.25$ S/m; $\epsilon_r = 46.29$; $\rho = 1000$ kg/m³

Phantom section: Flat Section

Ambient Temperature (°C) : 22.8, Liquid Temperature (°C) : 21.1

Measurement Standard: DASYS (IEEE/IEC/ANSI C63.19-2007)

DASY5 Configuration:

- Probe: EX3DV4 - SN3661; ConvF(3.97, 3.97, 3.97); Calibrated: 1/15/2013;
- Sensor-Surface: 1.4mm (Mechanical Surface Detection)
- Electronics: DAE4 Sn1207; Calibrated: 5/22/2013
- Phantom: SAM with right table; Type: SAM;
- Measurement SW: DASY52, Version 52.8 (5); SEMCAD X Version 14.6.8 (7028)

Configuration/Body/Area Scan (7x9x1): Measurement grid: dx=12mm, dy=12mm

Maximum value of SAR (measured) = 2.35 W/kg

Configuration/Body/Zoom Scan (7x7x12) (7x7x12)/Cube 0: Measurement grid:

dx=4mm, dy=4mm, dz=2mm

Reference Value = 7.482 V/m; Power Drift = -0.18 dB

Peak SAR (extrapolated) = 4.05 W/kg

SAR(1 g) = 0.928 W/kg; SAR(10 g) = 0.251 W/kg

Maximum value of SAR (measured) = 2.39 W/kg

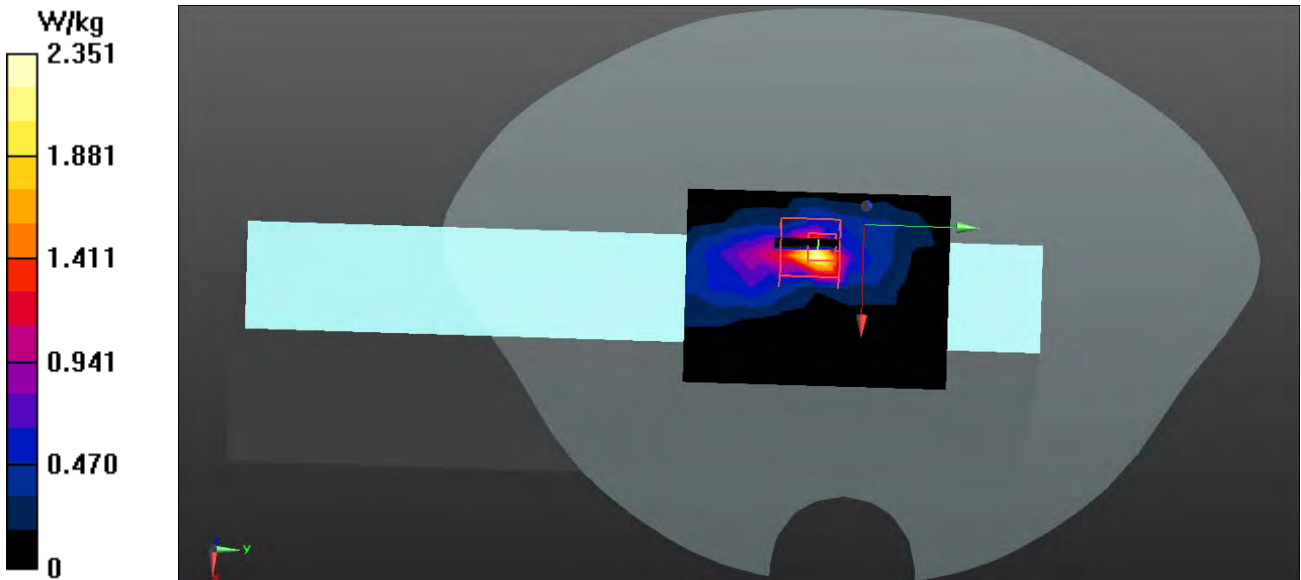

Antenna Kit : MilDef Crete Inc. Aux Antenna, P/N: DK10 Aux Antenna

Test Laboratory: QuieTek

Date/Time: 7/27/2013

802.11n-40M_5755-Top TX2

DUT: Handheld Computer; Type: DK10

Communication System: WLAN 5G; Frequency: 5755 MHz;

Communication System PAR: 0 dB

Medium parameters used: $f = 5755 \text{ MHz}$; $\sigma = 6.23 \text{ S/m}$; $\epsilon_r = 46.48$; $\rho = 1000 \text{ kg/m}^3$

Phantom section: Flat Section

Ambient Temperature (°C) : 22.8, Liquid Temperature (°C) : 21.1

Measurement Standard: DASYS (IEEE/IEC/ANSI C63.19-2007)

DASY5 Configuration:

- Probe: EX3DV4 - SN3661; ConvF(3.97, 3.97, 3.97); Calibrated: 1/15/2013;
- Sensor-Surface: 1.4mm (Mechanical Surface Detection)
- Electronics: DAE4 Sn1207; Calibrated: 5/22/2013
- Phantom: SAM with right table; Type: SAM;
- Measurement SW: DASY52, Version 52.8 (5); SEMCAD X Version 14.6.8 (7028)

Configuration/Body/Area Scan (7x9x1): Measurement grid: dx=12mm, dy=12mm

Maximum value of SAR (measured) = 2.36 W/kg

Configuration/Body/Zoom Scan (7x7x12) (7x7x12)/Cube 0: Measurement grid:

dx=4mm, dy=4mm, dz=2mm

Reference Value = 13.745 V/m; Power Drift = -0.11 dB

Peak SAR (extrapolated) = 4.19 W/kg

SAR(1 g) = 0.917 W/kg; SAR(10 g) = 0.235 W/kg

Maximum value of SAR (measured) = 2.45 W/kg

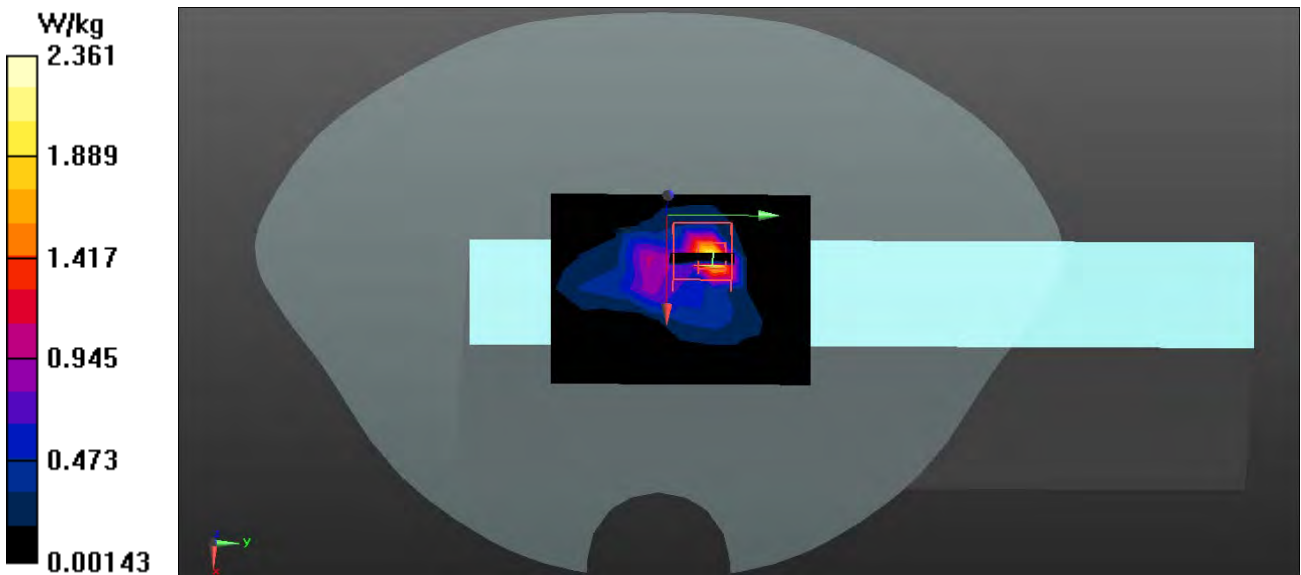

Test Laboratory: QuieTek

Date/Time: 7/27/2013

802.11n-40M_5795-Top TX2

DUT: Handheld Computer; Type: DK10

Communication System: WLAN 5G; Frequency: 5795 MHz;

Communication System PAR: 0 dB

Medium parameters used: $f = 5795$ MHz; $\sigma = 6.25$ S/m; $\epsilon_r = 46.29$; $\rho = 1000$ kg/m³

Phantom section: Flat Section

Ambient Temperature (°C) : 22.8, Liquid Temperature (°C) : 21.1

Measurement Standard: DASYS (IEEE/IEC/ANSI C63.19-2007)

DASY5 Configuration:

- Probe: EX3DV4 - SN3661; ConvF(3.97, 3.97, 3.97); Calibrated: 1/15/2013;
- Sensor-Surface: 1.4mm (Mechanical Surface Detection)
- Electronics: DAE4 Sn1207; Calibrated: 5/22/2013
- Phantom: SAM with right table; Type: SAM;
- Measurement SW: DASY52, Version 52.8 (5); SEMCAD X Version 14.6.8 (7028)

Configuration/Body/Area Scan (7x9x1): Measurement grid: dx=12mm, dy=12mm

Maximum value of SAR (measured) = 2.48 W/kg

Configuration/Body/Zoom Scan (7x7x12) (7x7x12)/Cube 0: Measurement grid:

dx=4mm, dy=4mm, dz=2mm

Reference Value = 14.533 V/m; Power Drift = -0.18 dB

Peak SAR (extrapolated) = 4.35 W/kg

SAR(1 g) = 0.948 W/kg; SAR(10 g) = 0.244 W/kg

Maximum value of SAR (measured) = 2.53 W/kg

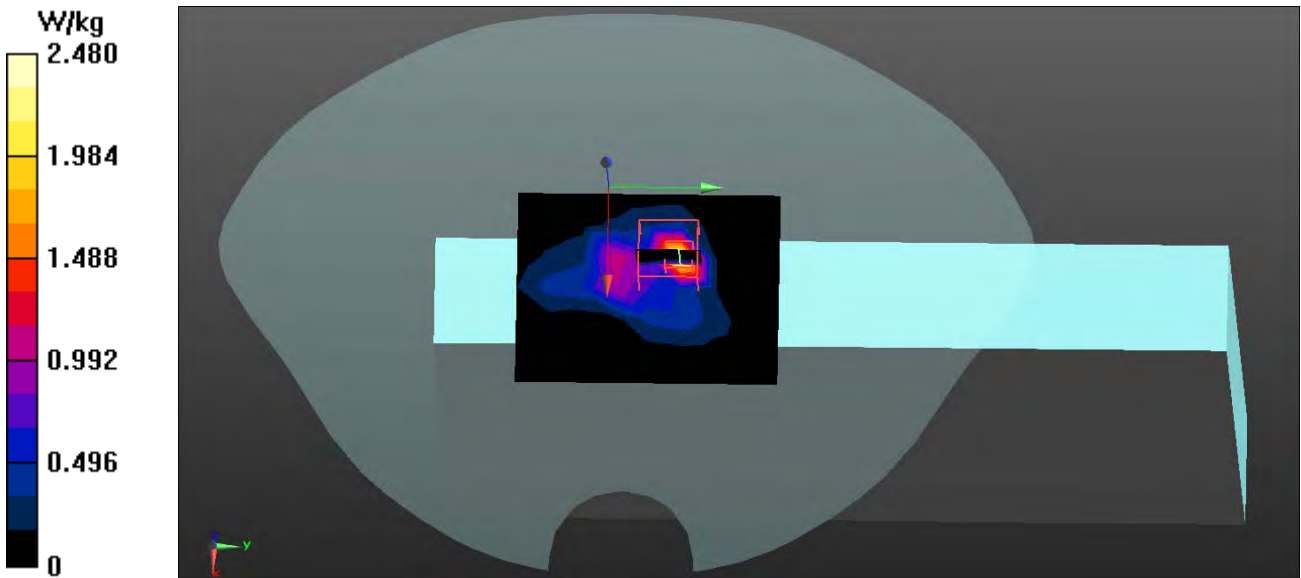

802.11a Main Antenna EUT Top, Z-Axis plot
Channel: 149

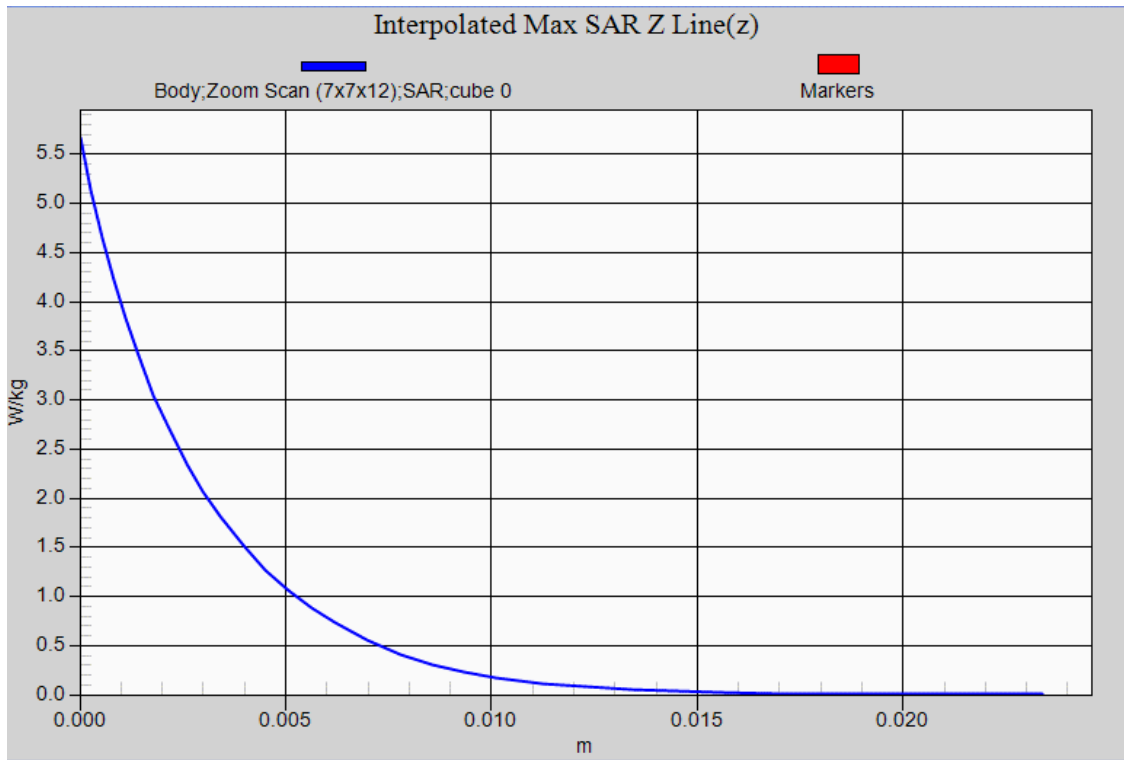

Antenna Kit : MilDef Crete Inc. Main Antenna, P/N: DK10 Main Antenna

Test Laboratory: QuieTek

Date/Time: 7/27/2013

802.11a_5745-Top TX1-Verify

DUT: Handheld Computer; Type: DK10

Communication System: WLAN 5G; Frequency: 5745 MHz;

Communication System PAR: 0 dB

Medium parameters used: $f = 5745 \text{ MHz}$; $\sigma = 6.21 \text{ S/m}$; $\epsilon_r = 46.65$; $\rho = 1000 \text{ kg/m}^3$

Phantom section: Flat Section

Ambient Temperature (°C) : 22.8, Liquid Temperature (°C) : 21.1

Measurement Standard: DASYS (IEEE/IEC/ANSI C63.19-2007)

DASY5 Configuration:

- Probe: EX3DV4 - SN3661; ConvF(3.97, 3.97, 3.97); Calibrated: 1/15/2013;
- Sensor-Surface: 1.4mm (Mechanical Surface Detection)
- Electronics: DAE4 Sn1207; Calibrated: 5/22/2013
- Phantom: SAM with right table; Type: SAM;
- Measurement SW: DASY52, Version 52.8 (5); SEMCAD X Version 14.6.8 (7028)

Configuration/Body/Area Scan (7x9x1): Measurement grid: $dx=12\text{mm}$, $dy=12\text{mm}$

Maximum value of SAR (measured) = 4.64 W/kg

Configuration/Body/Zoom Scan (7x7x12) (7x7x12)/Cube 0: Measurement grid:

$dx=4\text{mm}$, $dy=4\text{mm}$, $dz=2\text{mm}$

Reference Value = 10.982 V/m; Power Drift = -0.11 dB

Peak SAR (extrapolated) = 7.65 W/kg

SAR(1 g) = 1.23 W/kg; SAR(10 g) = 0.382 W/kg

Maximum value of SAR (measured) = 4.57 W/kg

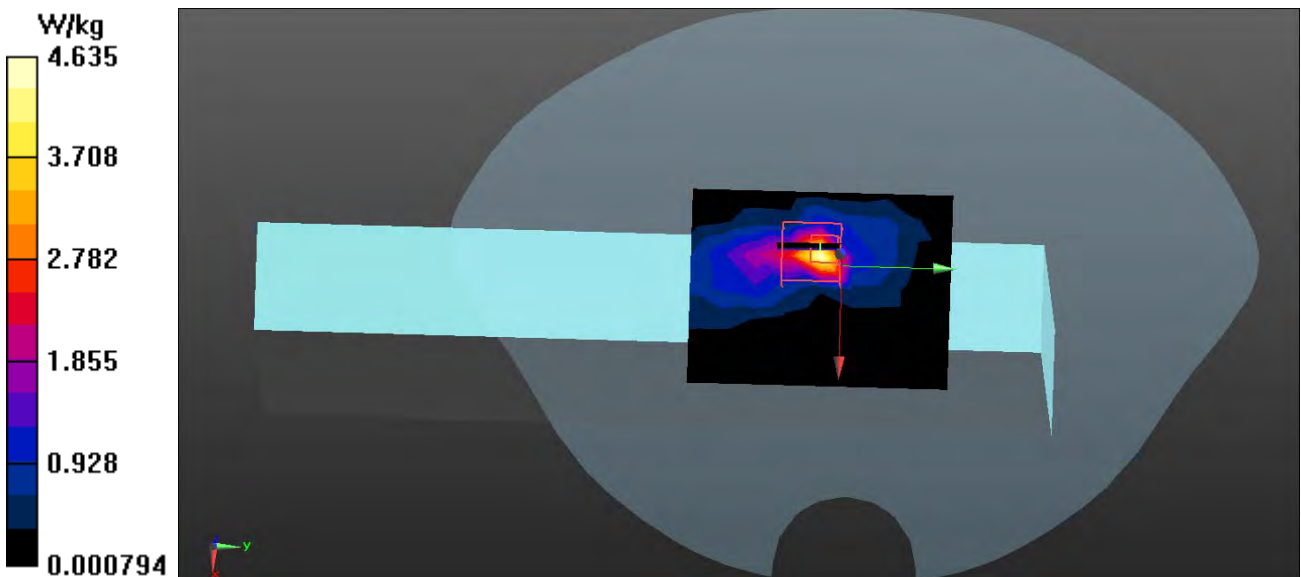

Appendix C. Test Setup Photographs & EUT Photographs
Test Setup Photographs

EUT Top (Main)

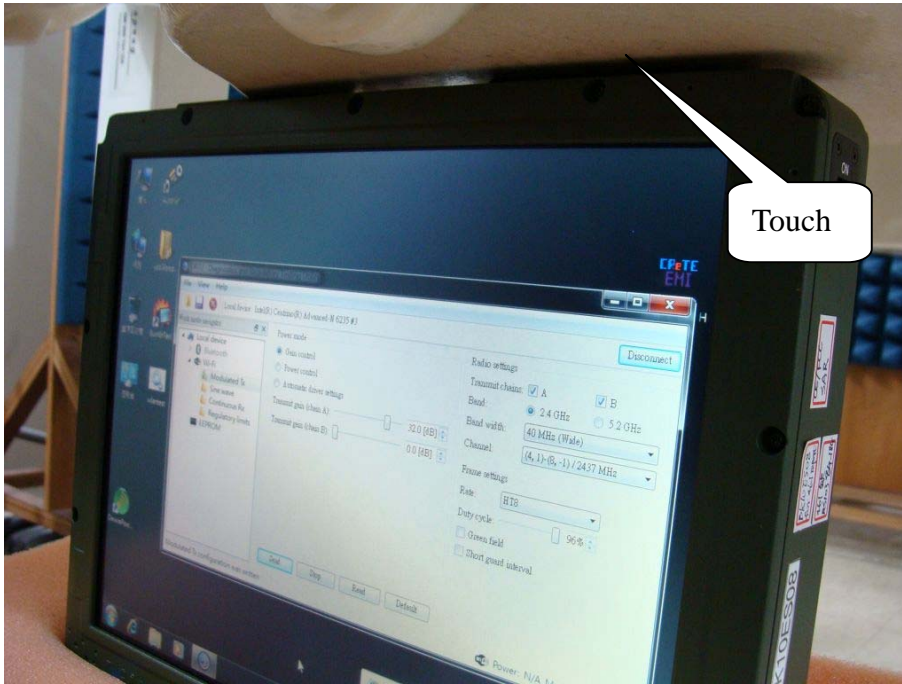

EUT Back (Main)



EUT R-Side (Main)



EUT Top (Aux)



EUT Back (Aux)

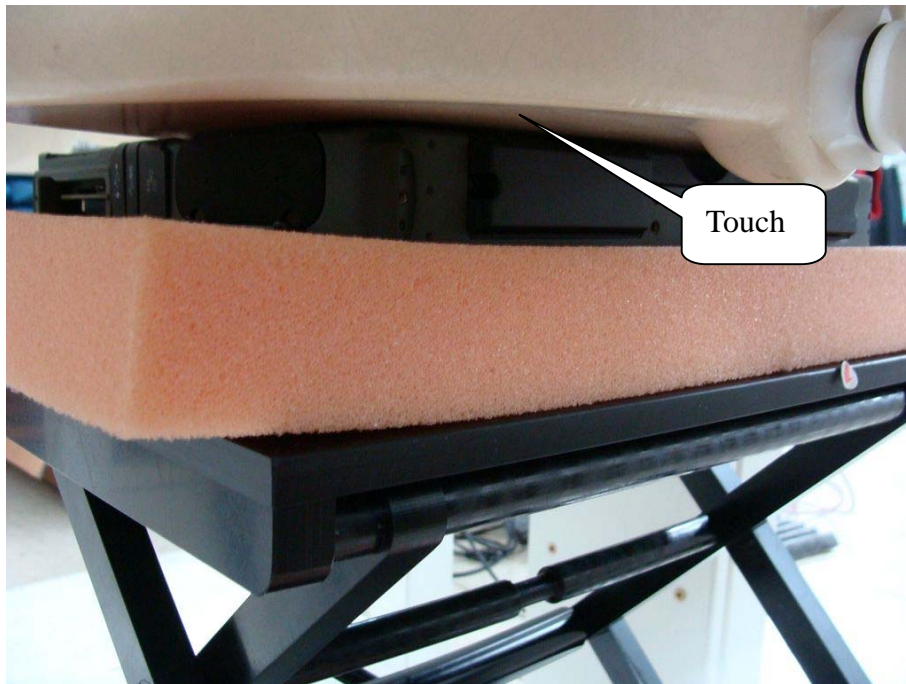

L-Side (Aux)

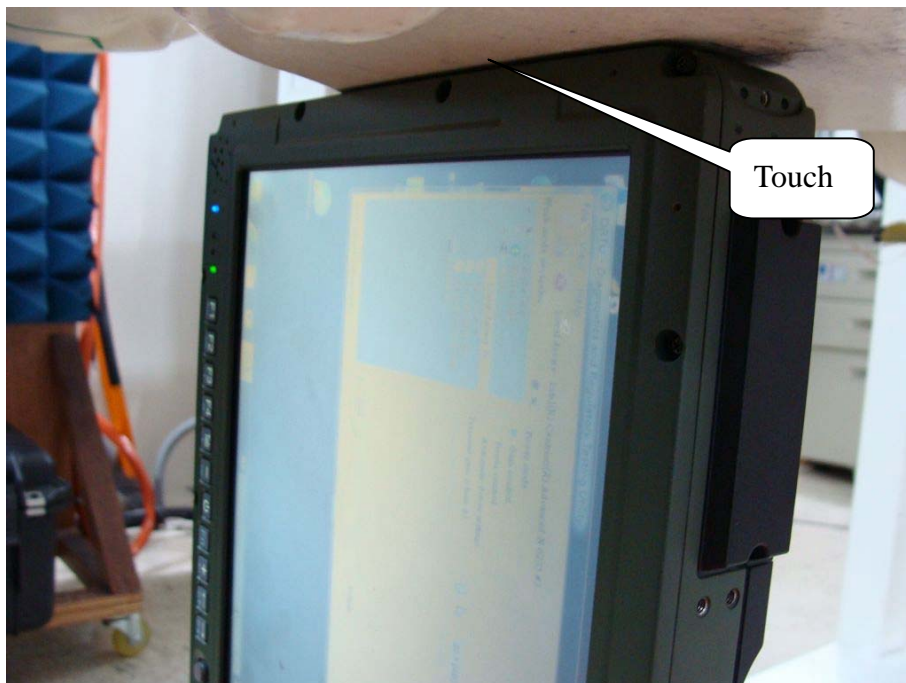

Depth of the liquid in the phantom-Zoom In



Note: The positions used in the measurements were according to IEEE 1528-2003.

EUT Photographs





