

# USER MANUAL

## Integrated Sensor Suite



For Vantage Pro2™, Vantage Pro2 GroWeather  
and Vantage Pro2 Plus™

**Davis** ®

Davis Instruments, 3465 Diablo Avenue, Hayward, CA 94545-2778 U.S.A. • 510-732-9229 • [www.davisinstruments.com](http://www.davisinstruments.com)



## FCC Part 15 Class B Registration Warning

This equipment has been tested and found to comply with the limits for a Class B digital device, pursuant to Part 15 of the FCC Rules. These limits are designed to provide reasonable protection against harmful interference in a residential installation. This equipment generates, uses, and can radiate radio frequency energy and, if not installed and used in accordance with the instructions, may cause harmful interference to radio communications. However, there is no guarantee that interference will not occur in a particular installation.

This device complies with part 15 of the FCC Rules. Operation is subject to the following two conditions: (1) this device may not cause harmful interference, and (2) this device must accept any interference, including interference received, including inference that may cause undesired operation.

This device complies with Industry Canada license-exempt RSS standard(s). Operation is subject to the following two conditions: (1) this device may not cause interference, and (2) this device must accept any interference, including interference that may cause undesired operation of the device.

Le présent appareil est conforme aux CNR d'Industrie Canada applicables aux appareils radio exempts de licence. L'exploitation est autorisée aux deux conditions suivantes: (1) l'appareil ne doit pas produire de brouillage, et (2) l'appareil doit accepter tout brouillage radioélectrique subi, même si le brouillage est susceptible d'en compromettre le fonctionnement.

The antenna used for this transmitter must be installed to provide a separation distance of at least 20 cm from all persons and must not be co-located or operating in conjunction with any other antenna or transmitter.

If this equipment does cause harmful interference to radio or television reception, which can be determined by turning the equipment on and off, the user is encouraged to try to correct the interference by one or more of the following measures:

- Reorient or relocate the receiving antenna.
- Increase the separation between the equipment and receiver.
- Connect the equipment into an outlet on a circuit different from that to which the receiver is connected.
- Consult the dealer or an experienced radio/TV technician for help.

Changes or modification not expressly approved in writing by Davis Instruments may void the warranty and void the user's authority to operate this equipment.

FCC ID: IR2DWW6329

IC: 3788A-6329

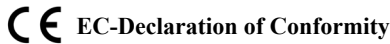

## EC-Declaration of Conformity

Directive 2014/53/EU (RED Directive)

**Manufacturer/responsible person:** Davis Instruments  
Compliance Engineer  
3465 Diablo Ave., Hayward, CA 94545 USA

**Hereby declares that the products:**

6152, 6153, 6163, 6322, 6323, 6327, 6328, 6329, 6334, 6820, 6825 OV EU UK

Comply with Directive 2014/53/EU. The full text of the EU Declaration of Conformity is on our website at <https://www.davisinstruments.com/legal>. RoHS Compliant.

# Contents

Introduction .....	1
Included Components and Hardware .....	2
Prepare the Sensor Suite for Installation .....	5
Cabled Sensor Suite Assembly .....	11
Wireless Sensor Suite Assembly .....	14
Plan the Sensor Suite Installation.....	19
Install the Sensor Suite.....	24
Maintenance and Troubleshooting .....	33
Contacting Technical Support .....	42
Appendix: Specifications .....	43



# Introduction

---

**Note:** Translated Vantage Pro2 manuals are available in the support section of [www.davisinstruments.com](http://www.davisinstruments.com).

*Les manuels traduits de Vantage Pro2 sont disponibles dans la section support de [www.davisinstruments.com](http://www.davisinstruments.com).*

*Los manuales traducidos de Vantage Pro2 están disponibles en la sección de soporte de [www.davisinstruments.com](http://www.davisinstruments.com).*

*Übersetzte Vantage Pro2-Handbücher sind im Support-Bereich von [www.davisinstruments.com](http://www.davisinstruments.com) verfügbar.*



Suite de Capteurs  
Conjunto de Sensores  
Sensor-Suite

The Integrated Sensor Suite collects outside weather data and sends the data to a Vantage Pro2 console. The wireless sensor suite can also transmit data to WeatherLink Live, a Vantage Vue console, or other Davis wireless receiver. The wireless sensor suite is solar-powered and sends data via radio. The cabled sensor suite sends data via cable to one cabled Vantage Pro2 console, cabled Weather Envoy, or cabled Vantage Connect and receives power via the console.

---

**Tip:** *One wireless sensor suite can transmit to any number of receivers within its range, so you can add additional receivers or consoles to use in different rooms.*

---

All Vantage Pro2 sensor suites include a rain collector, temperature sensor, humidity sensor, and anemometer. Temperature and humidity sensors are mounted in a passive or fan-aspirated radiation shield to minimize the impact of solar radiation on sensor readings. The anemometer measures wind speed and direction and can be installed adjacent to the sensor suite or apart from it. See “Locating the Sensor Suite and Anemometer” on page 19 for siting guidelines.

The transmitter shelter contains the “brain” of the sensor suite: the sensor interface and the transmitter. It collects outside weather data from the sensor suite sensors and then transmits the data to your Vantage Pro2 console, Vantage Vue console (wireless only), WeatherLink Live (wireless only), Weather Envoy, or Vantage Connect.

Other versions of the sensor suite have additional features:

- **Wireless Vantage Pro2 with Fan** (product number 6153): Includes a 24-Hour Fan-Aspirated Radiation Shield.
- **Wireless and cabled Vantage Pro2 Plus** (product numbers 6162 & 6162C): Includes a pre-installed Solar Radiation Sensor and a UV Sensor.
- **Wireless Vantage Pro2 Plus with Fan** (product number 6163): Includes UV and Solar Radiation Sensors, and a 24-Hour Fan-Aspirated Radiation Shield.
- **Wireless and Cabled GroWeather** (product numbers 6820 & 6820C) include a a Solar Radiation Sensor.
- **Wireless and Cabled GroWeather with 24-Hour Fan-Aspirated Radiation Shield** (product number 6825 & 6825C) and Solar Radiation Sensor.

---

**Tip:** Separate Solar Sensor (prod. no. 6450), UV Sensor (prod. no. 6490), Sensor Mounting Shelf (prod. no. 6673), and Daytime Fan-Aspirated Radiation Shield (prod. no. 7747) are available to upgrade a standard sensor suite.

---

## Included Components and Hardware

The sensor suite comes with all the components and hardware shown in the following illustrations. If you purchased your sensor suite as part of a weather station package containing the Vantage Pro2 console, additional components may be included in the package that are not shown here.

## Components

### VANTAGE PRO2 SENSOR SUITE with standard radiation shield

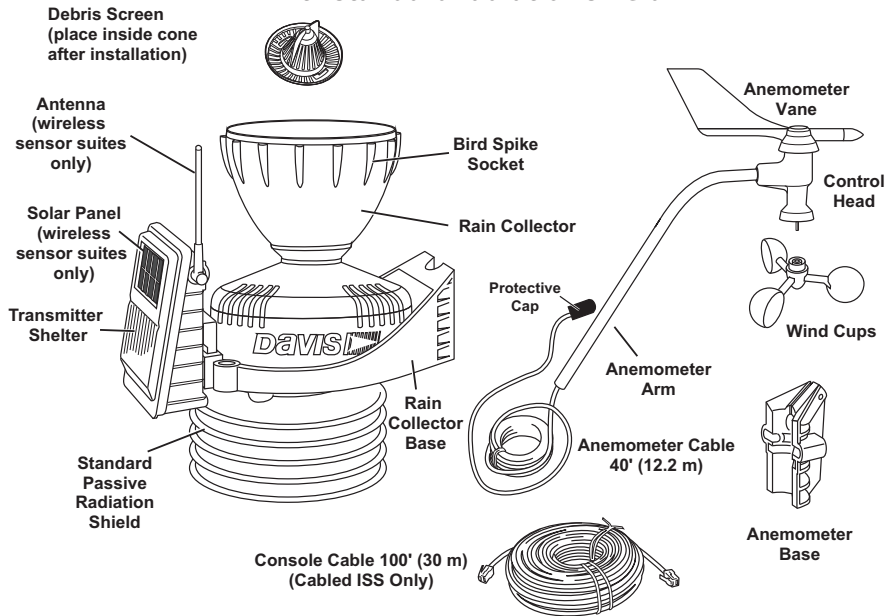

---

Other versions of the sensor suite have additional features and parts:

**VANTAGE PRO2 PLUS or GroWeather  
with Standard Radiation Shield**

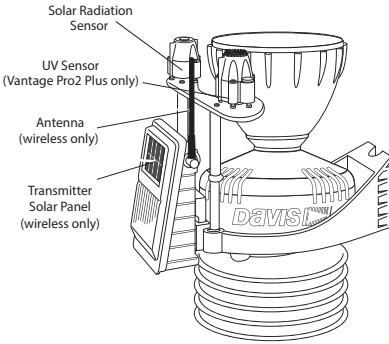

**VANTAGE PRO2  
with 24-Hour Fan-Aspirated Shield**

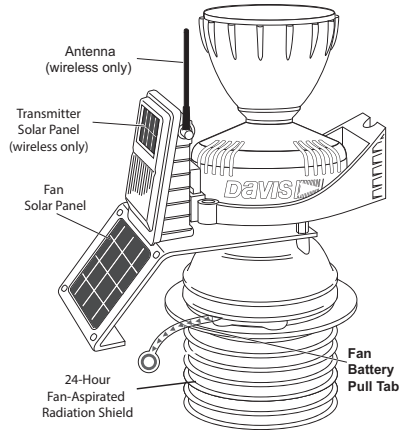

**VANTAGE PRO2 PLUS or GroWeather  
with 24-Hour Fan-Aspirated Shield**

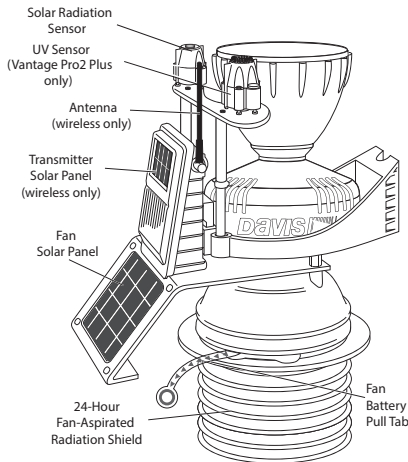

---

**Note:** If the sensor suite has UV and solar radiation sensors, do not touch the small white diffusers on top of the sensors. Oil from skin reduces their sensitivity. If you are concerned that you have touched the diffuser at any time during the installation, clean the diffuser with a soft cloth.

---

# Hardware (Included)

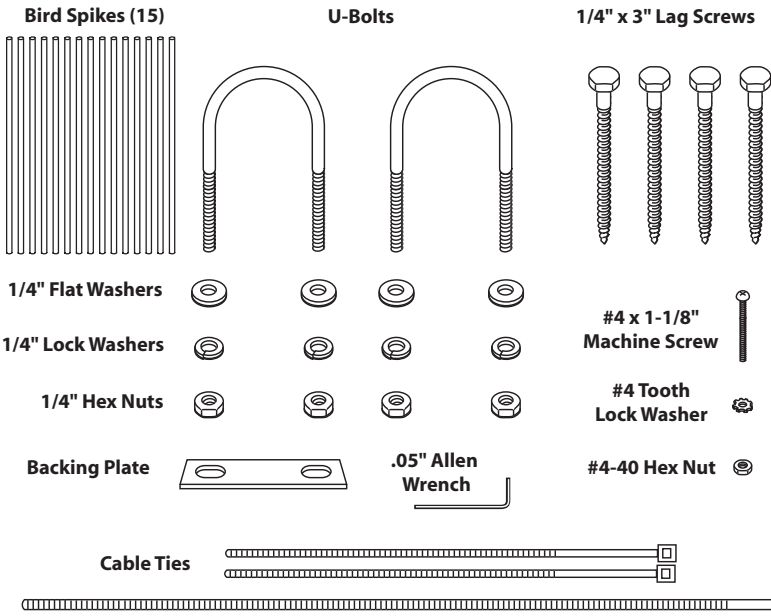

Some of the hardware is optional based on how the sensor suite is assembled and installed.

**Note:** If any of the hardware components are missing or not included, contact Customer Service toll free at 1-800-678-3669 about receiving replacements.

## Tools for Setup

- Wire cutter
- Small Phillips-head screwdriver (electric if possible)
- Adjustable wrench or 7/16" wrench
- Compass or local area map
- Ballpoint pen or paper clip (or other small pointed object)
- Drill and 3/16" (5 mm) drill bit (if using lag bolts)
- Small hammer (if installing optional bird spikes)



# Prepare the Sensor Suite for Installation

Follow the steps in order as each builds on tasks completed in previous steps. These steps apply to all versions of the sensor suite, unless otherwise noted.

**Tip:** Use a well-lit work table or work area to prepare the sensor suite for installation.

## Assemble the Anemometer

The anemometer measures wind direction and speed. The anemometer arm comes partially assembled with the wind vane attached.

**Note:** Do not remove the vane.

Please locate the following parts to prepare the anemometer:

- Anemometer arm (wind vane and cable already attached)
- Anemometer base
- Wind cups
- Allen wrench (0.05")
- #4 machine screw, #4 tooth-lock washer, #4 hex nut

### Attach the Anemometer Arm to Base

1. Insert the anemometer arm into the base, sliding the cable through the notch in the base as shown in the illustration below.
2. Line up the small hole in the arm with the holes in the base.
3. Insert the machine screw through the holes in the base and arm. It may be helpful to use a screwdriver to insert the screw.

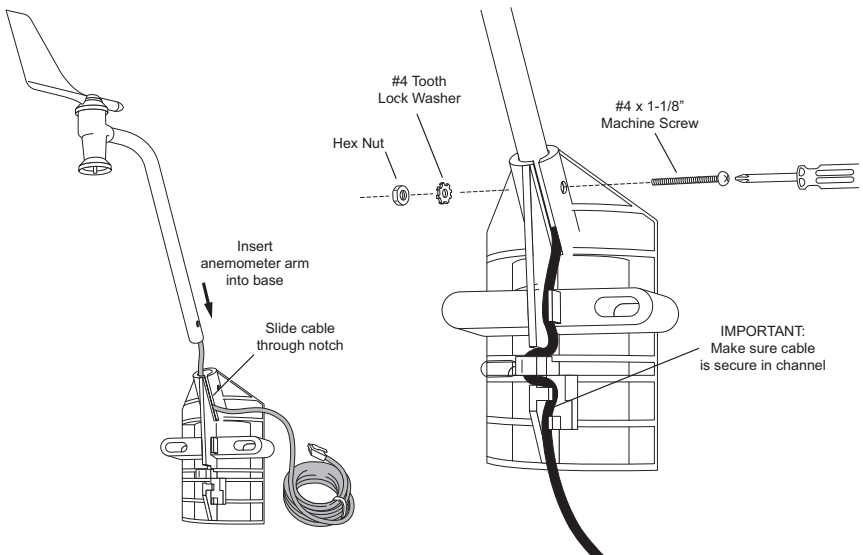

- 
- Slide the tooth-lock washer and hex nut onto the machine screw. Tighten the hex nut while holding the screw with a Phillips-head screwdriver to prevent it from turning.
  - Press the sensor cable firmly and completely into the zig-zagging channel in the base, starting from the arm and progressing downward to the bottom of the base. This provides strain relief for the cable.

### Attach the Wind Cups

- Push the wind cups up onto the anemometer's stainless steel shaft, sliding them up the shaft as far as possible.

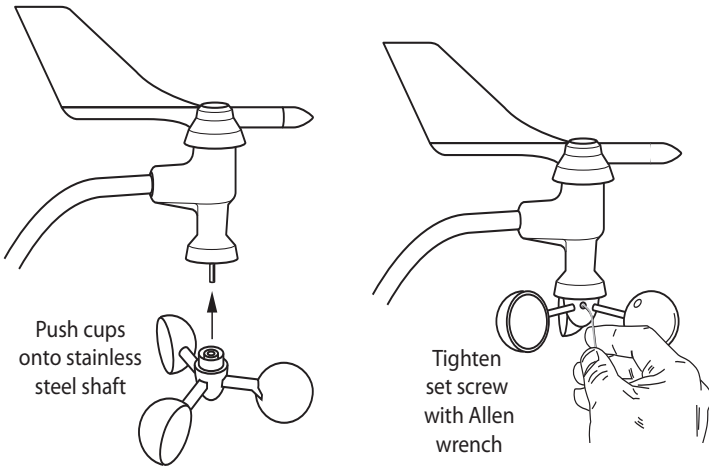

*Attaching the Wind Cups*

- Use the Allen wrench provided to firmly tighten the set screw on the side of the wind cups.  
The wind cups should drop slightly when you let go.
- Spin the wind cups. If they spin freely, the anemometer is ready and can be set aside while you prepare the rest of the sensor suite for installation.

---

**Note:** If the wind cups don't spin freely, take them off and repeat the wind cup installation process.

---

---

## Check Sensor Interface Connections and Connect the Anemometer Cable

The sensor interface is located in the transmitter shelter on the front of the sensor suite station. It contains the connections for all the sensors of the sensor suite. Follow the steps below to check the sensor interface and ensure that all sensors are connected properly.

### Open the Transmitter Shelter

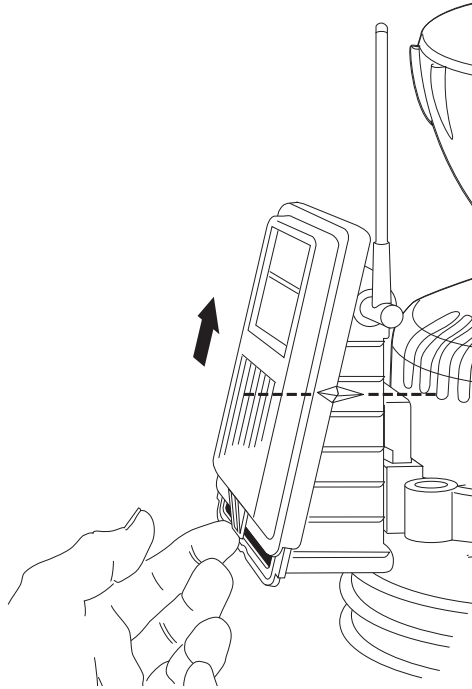

1. Locate the white box with the solar panel containing the sensor interface on the front of the sensor suite unit. (The cabled model does not have a solar panel.)
2. Locate the white tab at the bottom center of the shelter cover.
3. Pull the tab away from the box while sliding the cover up.
4. Look on the side of the shelter. The box cover can be easily removed from the box when the alignment indicator on the cover is lined up with the alignment indicator on the box
5. Pull the cover off the box, being careful not to stress the solar panel cable when removing the cover.
6. The sensor interface is visible once the cover has been removed.

---

Note: See “Sensor Interface” on page 44 for information on locating the components and points of interest on the sensor interface.

---

---

**Optional:**

Disconnect the solar panel connection wire (wireless versions) and the fan cable (fan versions).

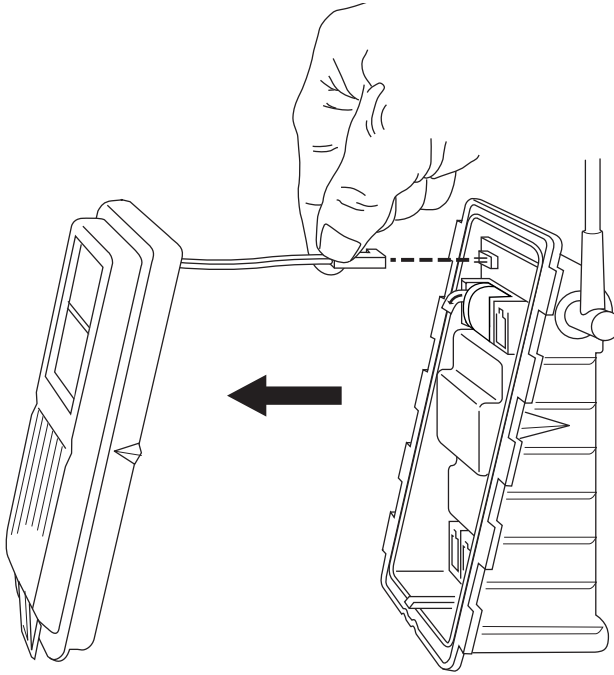

The solar panel on the box cover is connected to the sensor interface by a wire. If your sensor suite has a fan, the fan cable will also connect the cover to the sensor interface. If the cover cannot be set aside while still connected to the sensor interface safely, those cables can be disconnected.

---

## Check the Factory-Installed Sensor Connections

1. Verify that the rain collector and temperature/humidity sensor cables are plugged into the receptacles labeled RAIN and TEMP/HUM on the sensor interface.
2. If your sensor suite includes UV and/or solar radiation sensors, verify that the sensor cables are plugged into the receptacles labeled UV and SUN on the sensor interface.

## Connect the Anemometer Cable to the Sensor Interface

---

**Note:** The anemometer comes with 40 feet (12 meters) of cable to allow for mounting the anemometer separately from the rain collector and other sensors. The cable is coiled and secured at the factory with enough cable unwound from the coil to allow you to work with it and to allow the anemometer to be mounted on the same pole as the rain collector.

---

1. Remove the protective cap from the RJ jack on the anemometer cable.
2. Pull the foam insert out of cable access port and set the foam insert aside.
3. Insert the anemometer cable end into the cable access port from beneath the box.
4. Slide the cable through the cable access port with the connector lever down.
5. Firmly insert the end of the anemometer cable into the connector labeled WIND. The lever clicks into place.
6. Firmly insert the foam in between the cables and at the top of the cable access port, taking care to ensure that the foam seals the access port entirely, leaving no holes or gaps large enough for weather or insects. You may have to stack the cables to allow the foam to fit.

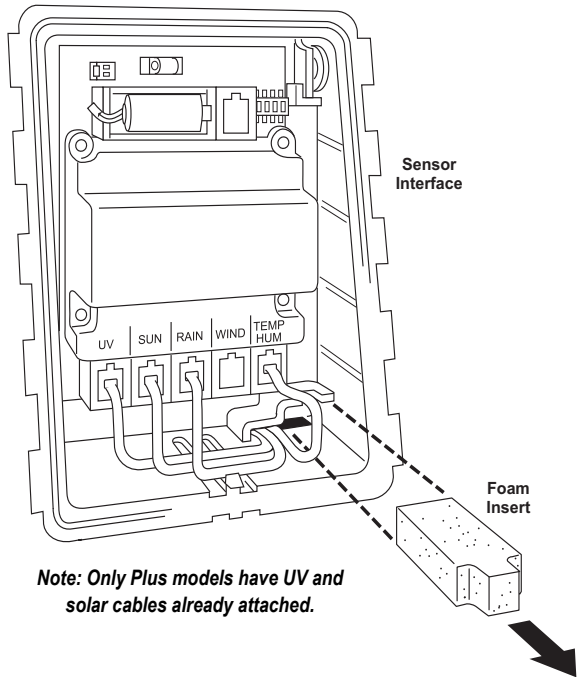

---

**Note:** If you are assembling a cabled station, wait to reinsert the foam until cable assembly is complete. See "Cabled Sensor Suite Assembly" on page 11.

---

---

## Prepare the Rain Collector

1. Remove the rain collector cone from the sensor suite base by rotating the cone counter-clockwise. When the cone's latches line up with openings in the base, lift the cone off the sensor suite base.

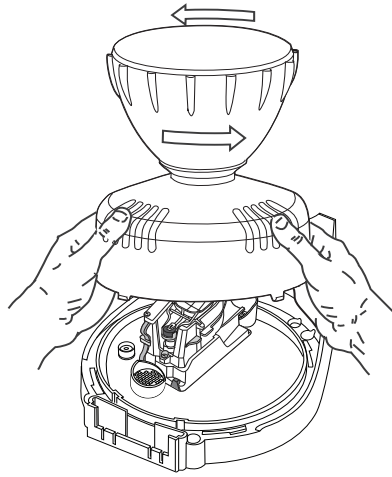

Twist off the rain collector cone

---

**Tip:** *When new, the cone fits tightly in the base and may require extra pressure to remove. Steady the sensor suite base between your knees when removing the cone.*

---

2. Carefully cut and remove the plastic tie that holds the tipping spoon in place during shipping (usually yellow or white in color).
3. Temporarily reinstall the rain collector cone until you are ready to mount the sensor suite.

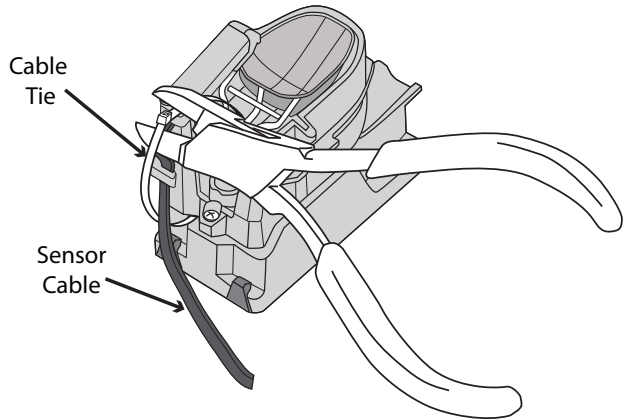

### Next Steps

- See “Cabled Sensor Suite Assembly” on page 11 for assembling a **cabled** Vantage Pro2 system
- See “Wireless Sensor Suite Assembly” on page 14 for assembling a **wireless** Vantage Pro2 system.

# Cabled Sensor Suite Assembly

## Apply Power and Verify Communication with the Console

The 100' (30 m) console cable provides power to the sensor suite and is used to send data from the sensor suite to the console. The console cable can be extended up to 1000' (305 m) in length with extension cables purchased from Davis Instruments. With the console powered, plugging the cable into the console powers the sensor suite and establishes communication between the sensor suite and the console.

1. Locate the 100' console cable included with your system.
2. Pull the foam insert out of cable access port, if it has been reinserted. Insert the console connector cable end into the cable access port from beneath the sensor interface box. Slide the cable through the cable access port with the connector tab down.
3. On the sensor interface, firmly insert either end of the 4-conductor cable into the modular receptacle labeled COMM.

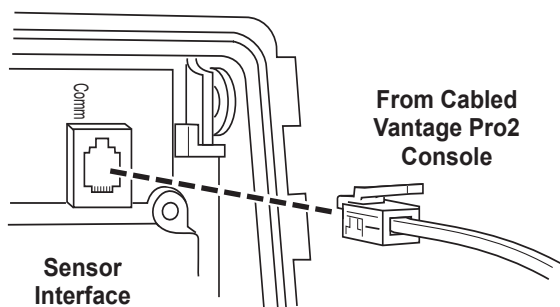

4. If you haven't powered up the console yet, refer to the installation instructions in the *Vantage Pro2 Console User Manual* and apply power to the console.
5. On the bottom of your console, insert the other end of the console cable into the modular receptacle labeled "ISS."
6. Firmly insert the foam in between the cables and at the top of the cable access port, taking care to ensure that the foam seals the access port entirely, leaving no holes or gaps for weather or insects. See the graphic on page 9 for more information on inserting the foam insert.
7. If the console is in Setup Mode, press and hold DONE until the Current Weather screen displays. A flashing "X" in the lower left hand corner indicates that the console is receiving data. Sensor readings from the sensor suite should display on the screen.

---

## Verify Data from the Sensor Suite Sensors

1. Near the center of the screen, look for the outside temperature (TEMP OUT).
2. Spin the wind cups to check wind speed, pressing WIND if necessary to alternate between speed and direction in the compass rose.
3. Turn the wind vane and allow five seconds for the wind direction display to stabilize before moving it again.
4. Approximately one minute after power-up the outside relative humidity (HUM OUT) reading should be displayed on the console.
5. Check to see if your console is receiving rain readings. On your console screen, look for the DAILY RAIN display. Remove the rain collector cone and tip the spoon, then wait to see if the display registers a rain reading. Each tip indicates 0.01" or 0.2 mm of rain and may take up to a minute to register at the console. If the spoon is tipped too quickly, the number on the console display may not change.
6. If the sensor suite contains a UV sensor and/or solar sensor, press 2ND and then press RAIN YR for current ultraviolet readings or press 2ND then press RAIN DAY for solar radiation readings.

The UV reading displays in the center of the console. The solar reading displays in the bottom right corner of the console display. UV and solar readings should be zero or close to zero if the sensor suite is inside. Zero is a valid reading. Dashes(-) are displayed if no data comes from the sensors.

7. Current weather data displayed on the console confirms communication.

Once the sensor suite has been powered and the console has successfully received accurate readings from all the sensors, prepare the sensor suite for installation. Continue on to "Plan the Sensor Suite Installation" on page 19.

If there is a communication problem between the wireless sensor suite and the console, see below: "Troubleshooting Cabled Sensor Suite Communication" on page 13.

To make installation easier at a location, disconnect the console cable from the sensor interface. Remove the foam and slide the cable out through access port. Once a location for both the sensor suite and the console has been arranged, reinsert the cable through the access port, into the console connector, and reinsert the foam.



---

## Troubleshooting Cabled Sensor Suite Communication

If the console is not receiving sensor readings from the sensor suite, try the following troubleshooting procedures.

- Check the console to make sure it is being powered with the AC adapter supplied in the Vantage Pro2 package or three C batteries.

---

**Note:** The batteries are intended for backup power, or for testing during set up, but they will drain quickly if used to power a cabled console. You should always use the AC adapter to power your system for normal use. The supplied adapter is a 5-volt positive center AC to DC adapter. Other adapters may not work if the voltage or adapter type is different.

---

- Make sure the cable is firmly plugged into the sensor suite ("ISS") jack on the console.
- Make sure that the cable is firmly plugged into the jack labeled COMM on the sensor interface.
- Verify that all sensor cables are firmly plugged in.
- A green LED indicator light on the sensor interface flashes each time the sensor suite transmits a packet, which is about once every 2.5 seconds. If the LED remains dark, there is no power to the sensor suite. Call Technical Support. See "Contacting Technical Support" on page 42.

See "Sensor Interface" on page 44 for information on locating the LED indicator light.

If the console is still not receiving readings, ensure that the console is in Setup Mode and reboot the console by disconnecting the AC power adapter from the console and removing the console batteries for at least 30 seconds. If the console is still not displaying sensor readings from the sensor suite after powering back up, please contact Davis Technical Support.

# Wireless Sensor Suite Assembly

---

The sensor suite has a wireless connection to a Vantage Pro2 wireless console or other receiver. Once the anemometer has been installed and the sensor connections have been checked, the sensor suite must be powered and a wireless communication channel must be established between the sensor suite and the receiver.

## Apply Power to the Wireless Sensor Suite

Energy from the solar panel is stored for power at night. A factory-installed lithium battery is an alternative power source the sensor interface uses when it is depleted. In the sensor transmitter, remove the battery pull tab. Make sure the battery is firmly seated. Once powered, the sensor suite immediately begins transmitting data.

## Check Transmitter ID

A Vantage Pro2 console can receive data from up to 8 different wireless transmitters. The default Transmitter ID for the sensor suite and console is 1.

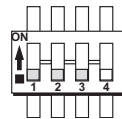

Settings for Transmitter ID 1:  
DIP Switch 1 = OFF  
DIP Switch 2 = OFF  
DIP Switch 3 = OFF

In most cases it will not be necessary to change the Transmitter ID. The console and sensor suite should begin communicating automatically when power is applied.

---

**Note:** If another Davis weather station is within range of your console or Vantage Connect, you should change the Transmitter ID. Remember to use the same ID for the sensor suite and console. See “Optional: Changing the Sensor Suite Transmitter ID” on page 17.

---

## Verify Communication with a Console

1. Power the console if it does not already have power. Refer to the *Vantage Pro2 Console User Manual* and apply power to the console. The console automatically enters Setup Mode when powered up.
2. If the console is not in Setup Mode, press and hold DONE then press the down arrow. The message RECEIVING FROM... and STATION NO. followed by the Transmitter IDs that the console detects displays on the console screen.
3. Look for the sensor suite Transmitter ID. The number 1 displays unless the Transmitter ID has been changed. If the sensor suite Transmitter ID is displayed, the sensor suite is detected.

---

**Note:** If the console does not display the number of the sensor suite Transmitter ID setting, see “Troubleshooting Wireless Sensor Suite Reception” on page 16 for more information. It can take several minutes for the console to acquire and display all the available Transmitter IDs.

---

4. Press and hold DONE to view sensor suite data once the sensor suite Transmitter ID displays.

---

## Verify Data from the Sensor Suite Sensors

### ***On a console:***

1. If the console is in Setup Mode, press and hold DONE until the Current Weather screen displays. A flashing “X” in the lower right hand corner indicates that the console is receiving data packets. This may take a few minutes.  
Sensor readings from the sensor suite should display on the screen.
2. Near the center of the screen, look for the outside temperature (TEMP OUT).
3. Spin the wind cups to check wind speed, pressing WIND if necessary to alternate between speed and direction in the compass rose.
4. Turn the wind vane, and allow 5 seconds for the wind direction display to stabilize before moving it again.
5. Approximately one minute after receiving data, the outside relative humidity (HUM OUT) reading should be displayed on the console.
6. If the sensor suite contains a UV sensor and/or solar radiation sensor, press 2ND and then press RAIN YR for current ultraviolet readings or press 2ND then press RAIN DAY for solar radiation readings.
7. The UV reading displays in the center of the console. The solar reading displays in the bottom right corner of the console display. UV and solar readings should be zero or close to zero if the sensor suite is inside. Zero is a valid reading — dashes are displayed if no data comes from the sensors.
8. Current weather data displayed on the console confirms successful communication.

### ***On a WeatherLink Live (no console):***

If you are using your Vantage Pro2 sensor suite with a WeatherLink Live without a console, you will need to set up your WeatherLink Live and your account on WeatherLink.com in order to see incoming data. However, during setup and installation, erroneous data may be received by the WeatherLink Live and this data will become part of your archive. For example, if you verify data while your sensor suite is inside your home or workshop, an erroneous “outside” temperature will be recorded; if you tip the rain tipping spoon while mounting the sensor suite, erroneous rain will be recorded.

To avoid erroneous data, you may want to place your sensor suite outside before powering up your WeatherLink Live. Wait to see outside temperature data on WeatherLink.com, which may take up to 10 minutes.

Be sure to power down the WeatherLink Live until after final installation.

Once the sensor suite has been powered and the console and/or WeatherLink Live has successfully received accurate readings from all the sensors, prepare the sensor suite for installation. Continue on to “Plan the Sensor Suite Installation” on page 19 for more information.

If there is a communication problem between the wireless sensor suite and the console, see See “Troubleshooting Wireless Sensor Suite Reception” on page 16.

---

## Troubleshooting Wireless Sensor Suite Reception

If the console isn't displaying data from the sensor suite, perform the following steps:

1. Verify that the console is powered and is not in Setup Mode.
2. Make sure that all sensor suite sensor cables are firmly connected to the sensor interface and the sensor suite battery is properly installed.
3. Walk around the room with the console, standing for a few moments in various locations, to see if you are picking up signals from the sensor suite. Look on the screen's lower right corner. An "X" toggles on and off when the console receives a transmission packet. If an "R" appears, the console is trying to find the signal. If an "L" appears, the console is in "sleep" mode and will not try to find the signal until it "wakes up." See your *Vantage Pro2 Console User Manual* for more information.
4. If you do not see the "X" slowly blinking, no matter where you stand with the console, put your sensor suite in Test Mode.

- The DIP switch #4 on the sensor interface is the Test Mode switch. Switch it to the ON position, using a ball-point pen or paper clip.
- In test mode, a green LED indicator light on the sensor interface flashes each time the sensor suite transmits, which is about once every 2.5 seconds.

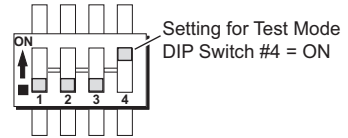

- See "Sensor Interface" on page 44 for information on locating the components and points of interest on the sensor interface.
5. If the LED remains dark, there is a problem with the sensor suite transmitter. Call Technical Support. See "Contacting Technical Support" on page 42.
  6. If the LED flashes repeatedly but your console isn't picking up a signal anywhere in the room, it could be related to one of the following causes:
    - You changed the sensor suite Transmitter ID at the sensor suite or console, but not at both.
    - Reception is being disrupted by frequency interference from outside sources. Interference has to be strong to prevent the console from receiving a signal while in the same room as the sensor suite. In high-interference environments, it may be preferable to install the Cabled Vantage Pro2.
    - There is a problem with the console.
  7. If a problem with receiving the wireless transmission still exists, please contact Technical Support. See "Contacting Technical Support" on page 42.
  8. When you are finished testing wireless transmission, set DIP switch # 4 to OFF to take the sensor interface out of Test Mode.

---

**Note:** If the sensor interface is left in Test Mode, the blinking LED will significantly reduce sensor suite battery life.

---

---

### **Optional: Changing the Sensor Suite Transmitter ID**

Each wireless transmitting station, including the sensor suite, uses one of eight selectable Transmitter IDs. DIP switches #1, 2 and 3 on the transmitter control the ID — or channel — the station transmits on. DIP switch #4 is used for transmission testing, not for the Transmitter ID.

---

**Note:** The transmitter on the sensor suite and the receiver on the console, WeatherLink Live or other receiver communicate with each other only when both are set to the same ID.

---

The default Transmitter ID is 1 for both the sensor suite and the Vantage Pro2 console, and should work fine for most situations. Change the Transmitter ID if any of the following issues are true:

- Another Davis Instruments wireless weather station operating nearby already uses Transmitter ID 1.
- You have purchased additional Vantage Pro2 or Vantage Vue wireless transmitting stations and one of the stations has already been designated as Station No. 1.

On the sensor suite, the Transmitter ID is set using the DIP switches located on the sensor interface. To access the sensor interface, open the transmitter shelter cover. (See page 7.)

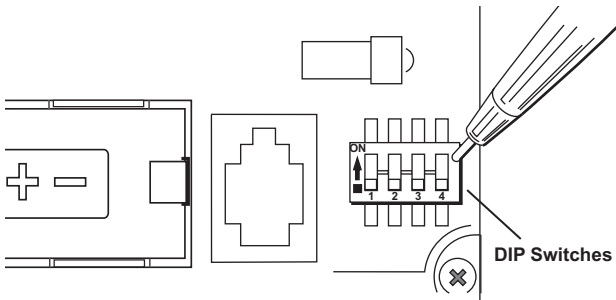

*Transmitter ID DIP switches in top-right corner of sensor interface*

To change to another ID, use a ballpoint pen or paper clip to toggle DIP switches #1, 2, and 3. The settings for Transmitter IDs 1 - 8 are shown in the table below. Set the Vantage Pro2 console to the same ID as the transmitters, as described in the *Vantage Pro2 Console User Manual*.

ID CODE	SWITCH 1	SWITCH 2	SWITCH 3
#1 (default)	off	off	off
#2	off	off	ON
#3	off	ON	off
#4	off	ON	ON
#5	ON	off	off
#6	ON	off	ON
#7	ON	ON	off
#8	ON	ON	ON

## Using Multiple Transmitting Stations

A single Vantage Pro2 console can receive signals from a **total** of up to eight transmitters with limitations as shown in the table below.

If you are using a WeatherLink Live, you may have up to eight different transmitters, in any combination, including eight sensor suites.

Maximum Number of Transmitters		
	Console	WeatherLink Live
Vantage Pro2 or Vantage Vue Sensor Suite	1	8
Sensor Transmitter with an Anemometer	1*	8
Leaf & Soil Moisture/Temperature Station	2**	8
Sensor Transmitter with a Temperature Probe	8	8
Sensor Transmitter with a Temp/Hum Sensor	8	8
Sensor Transmitter with any other combination of sensors	--	8

\*Replaces the sensor suite anemometer.

\*\*Two are allowable only if one stations has only leaf wetness and one has only soil moisture sensors. For example, a network can either have both a Leaf Wetness/Temperature station and a Soil Moisture/Temperature station, or it can have one combined Leaf Wetness and Soil Moisture/Temperature station.

# Plan the Sensor Suite Installation

---

## Locating the Sensor Suite and Anemometer

For the weather station to perform at its best, use these guidelines to select the optimum mounting locations for the sensor suite and anemometer. Be sure to take into consideration ease of access for maintenance, sensor cable lengths and wireless transmission range when siting the station.

---

Note: When selecting a location for installing your sensor suite, especially on a rooftop, make sure it is a location far from power lines. Seek professional help if you are uncertain about the safety of your installation.

---

### General Sensor Suite Siting Guidelines

- Place the sensor suite away from sources of heat such as chimneys, heaters, air conditioners and exhaust vents.
- Place the sensor suite at least 100' (30 m) away from any asphalt or concrete roadway that readily absorbs and radiates heat in the sun. Avoid installations near fences or sides of buildings that receive a lot of sun during the day.
- Ideally, place the radiation shield of the sensor suite 5' (1.5 m) above the ground in the middle of gently sloping or flat, regularly mowed grassy or naturally landscaped area that drains well when it rains. For areas with average maximum yearly snow depths over 3' (0.9 m), mount the sensor suite 2' (0.6 m) above this depth.
- Never install the sensor suite where it will be directly sprayed by a sprinkler system.
- Do not mount the sensor suite under tree canopies or near the side of buildings that create "rain shadows." For heavily forested areas, site the sensor suite in a clearing or meadow.
- Site the sensor suite in a location with good sun exposure throughout the day if the sensor suite is wireless or includes solar radiation or UV radiation sensors.

For *agricultural applications* (important for evapotranspiration (ET) calculations):

- Install the sensor suite and anemometer as a single unit with the radiation shield 5' (1.5 m) above the ground and in the middle of the farm between similar crop types (i.e. two orchards, two vineyards or two row crops), if possible.
- Avoid areas exposed to extensive or frequent applications of agricultural chemicals which can degrade the sensors.
- Avoid installing over bare soil. The ET formula works best when the sensor suite is installed over well-irrigated, regularly mowed grass.
- If the last three guidelines cannot be met, install the weather station at the edge of the primary crop of interest.

---

## Anemometer Siting Guidelines

- For best results, place the anemometer at least 7' (2.1 m) above surrounding obstructions such as trees or buildings that obstruct wind flow.
- If mounting on a roof, mount the anemometer at least 7' (2.1 m) above the roof apex. (When using a Davis Mounting Tripod, install the anemometer at the very top of the pole).
- If mounting the sensor suite and the anemometer together, such as on a pole or a wooden post, mount the anemometer so it is at least 12" (0.3 m) above the top of the rain collector cone for best results.
- The standard for meteorological and aviation applications is to place the anemometer 33' (10 m) above the ground. Seek professional help for this type of installation.
- The standard for *agricultural applications* is to place the anemometer 6' (2 m) above the ground. This is important for evapotranspiration (ET) calculations.

---

Note: For roof mounting, and ease of installation, we recommend using the optional mounting tripod (#7716). For other installations, use the Mounting Pole Kit (#7717).

---

Note: For more detailed siting suggestions, see Application Note #30: Reporting Quality Observations to NOAA in the support section of [www.davisinstruments.com](http://www.davisinstruments.com)

---



- All Vantage Pro2 stations include a 40' (12 m) cable to go between the sensor suite and the anemometer. This can be extended up to 540' (165 m) using optional extension cables purchased from Davis Instruments.

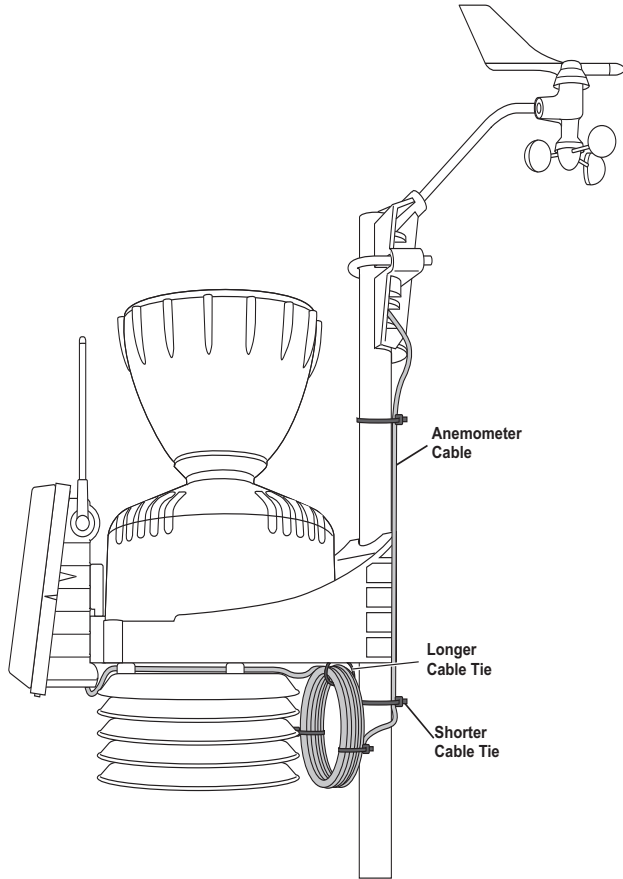

If most of the anemometer cable length is unused, the coiled cable length can be stowed once the anemometer and sensor suite have been installed on a site. You can secure the cable to the pole using the shorter cable ties. Use the longer cable tie to secure the coil by running it through the holes on the rain collector shelf. Keep the anemometer cable coiled if possible during the sensor suite and anemometer assembly so that it is easily stowed once installation is complete.

- The Cabled Vantage Pro2 includes a 100' (30 m) cable to go between the console and the sensor suite. This can be extended up to 1000' (300 m) using optional cables.

---

## Optional: Wireless Transmission Considerations

The range of the radio transmission depends on several factors. Try to position the transmitter and the receiver as close as possible for best results.

Typical maximum ranges include:

- Line of sight: 1000' (300 m).
- Under most conditions: 200 - 400' (60 - 120 m).

Other range and transmission considerations include:

- Range may be reduced by walls, ceilings, trees, foliage, a metal roof or other large metal structures or objects such as aluminum siding, metal ducts, and metal appliances, such as refrigerators, televisions, heaters, or air conditioners.
- Transmission between wireless units may be obscured by something unidentifiable, or by some obstacle that can't be worked around.
- For best results, orient the sensor suite antenna and the console antenna so that the orientation and angles of the antennas are parallel to each other.

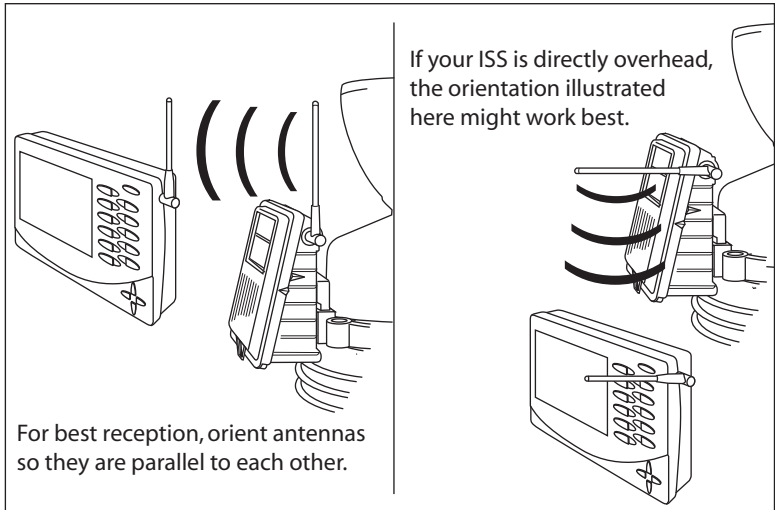

---

**CAUTION:** The sensor suite and console antennas do not rotate in a complete circle. **Avoid forcing the antennas when rotating them.**

---

- Consider using a Wireless Repeater (#7627) or Long-Range Wireless Repeater (#7654) to strengthen the signal or to increase the distance between the sensor suite and the console.
- You can use an additional Vantage Pro2 console (#6312) or Vantage Vue console (#6351) set to retransmit to increase transmission distance.

---

## Testing Wireless Transmission at Sensor Suite Location

After a suitable place has been found for the wireless sensor suite, it is very important to test reception from the installation location before permanently mounting it there.

1. Set the sensor suite in the desired installation location.
2. Set the powered-up console and/or WeatherLink Live in the desired location.

### Console:

1. Monitor your screen for data. You should see a flashing "X" in the lower right corner and data should start to appear. This may take a few minutes.
2. If data does not appear, press and hold TEMP and press HUM to display statistical and reception diagnostics on the console. See your *Vantage Pro2 Console User Manual* for more information on the diagnostic screens.
  - It's a good idea to test the console's reception anywhere that you might want to use or mount it now or in the future. Take your time. If you aren't picking up a strong signal where you intend to place your console, try rotating the antenna on the console and sensor suite or try moving the console and sensor suite to different positions.
  - Irregular terrain in the area may interfere with the signal. For example, if the sensor suite is mounted downhill from the console, the ground may block a large percentage of the transmitted signal.
  - Press and hold DONE to return to the Current Weather Mode when finished testing.

---

Note: See the Troubleshooting section of the *Vantage Pro2 Console User Manual* for information on how to check wireless signal strength and for more information on troubleshooting reception problems.

---

### WeatherLink Live:

1. Open your WeatherLink.com page.
2. Watch for outside temperature to appear on your page on WeatherLink.com
3. If data does not appear, click the Tools icon. (It looks like a wrench.) Choose Health Data. Make sure the DavisTalk RSSI signal strength is above -90.

---

Note: See the Troubleshooting section of the *WeatherLink Live User Manual* for information on how to check wireless signal strength and for more information on troubleshooting reception problems.

---

# Install the Sensor Suite

---

**Tip:** To avoid erroneous data during installation when using a WeatherLink Live, be sure the WeatherLink Live is powered down before installing the sensor suite.

---

The anemometer and the main part of the sensor suite can be installed either together as a single unit on a pole, or apart from each other. The main part of the sensor suite includes the rain collector, the temperature and humidity sensors, the radiation shield, and the sensor transmitter. Use the U-bolts to install the sensor suite and anemometer together or separately on a pole. Use the lag screws to install them separately on a flat, vertical surface.

- The anemometer comes with a 40' (12 m) cable for flexibility in positioning the system to monitor wind conditions. For example, the anemometer could be mounted at the highest point of a roof, and the sensor suite could be mounted on a fence closer to ground level.
- If you would like to install your anemometer even farther away from the sensor suite or without using a cable, use a Davis Solar-Powered Sensor Transmitter, #6332.

## General Sensor Suite Installation Guidelines

- **Install the sensor suite as level as possible to ensure accurate rain measurements.** Use the built-in bubble level (under the rain collector cone, near the tipping spoon mechanism) or carpenter's level to make sure the sensor suite is level.
- In the Northern Hemisphere, the solar panel should face south for maximum sun exposure, and the anemometer arm should point north for proper wind direction calibration.
- In the Southern Hemisphere, the solar panel should face north for maximum sun exposure. Either install the sensor suite and anemometer separately, each facing north, or mount them as a single unit with solar panel facing north and the wind vane re-oriented to the South. You will then need to calibrate your console. ( See "Orient the Wind Vane" on page 25.)

### **Optional: Guidelines for Securing Cables**

- To prevent fraying or cutting of cables, secure them so they will not whip about in the wind.
- Secure cable to a metal pole using cable ties or by wrapping tape around both the cables and the pole.
- Place clips or ties every 3' – 5' (1 – 1.6 m).
- Mounting clips, cable ties or additional hardware not included with your station can be easily obtained at a hardware or electronics store.

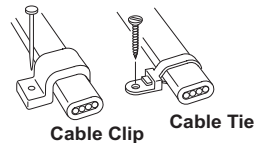

---

**Note:** Do not use metal staples or a staple gun to secure cables. Metal staples — especially when installed with a staple gun — have a tendency to cut the cables.

---

---

## **Orient the Wind Vane**

The wind vane rotates 360° to display current and dominant wind directions on the compass rose of the console display. To obtain accurate readings, the vane must be *correctly oriented* when mounting the anemometer. The wind vane is factory-calibrated to report the correct wind direction if the anemometer arm points true north.

To ensure correct wind direction data, mount the anemometer so that the arm points true north.

If your anemometer arm cannot be mounted aiming true north, you will need to calibrate the wind direction on your console to display accurate wind directions. See your *Vantage Pro2 Console User Manual*.

## Installation Options

There are several ways to mount and install the sensor suite unit. The following installations are recommended. Individual sensor suite locations and installations may vary.

- **Installing the sensor suite and anemometer on a post or flat surface**
- **Installing the sensor suite and anemometer on a pole, together or separately**

Note: All installations require that the rain collector cone be removed for assembly.

**Important: Use the built-in bubble level to ensure the main part of the sensor suite is level.**

**Tip:** *If most of the anemometer cable length is unused, the coiled cable length can be stowed once the anemometer and sensor suite have been installed on a site. You can secure the cable to the pole using the shorter cable ties. Use the longer cable tie to secure the coil by running it through the holes on the rain collector shelf. Keep the anemometer cable coiled if possible during the sensor suite and anemometer assembly so that it is easily stowed once installation is complete.*

## Installing the Sensor Suite and Anemometer on a Flat Surface

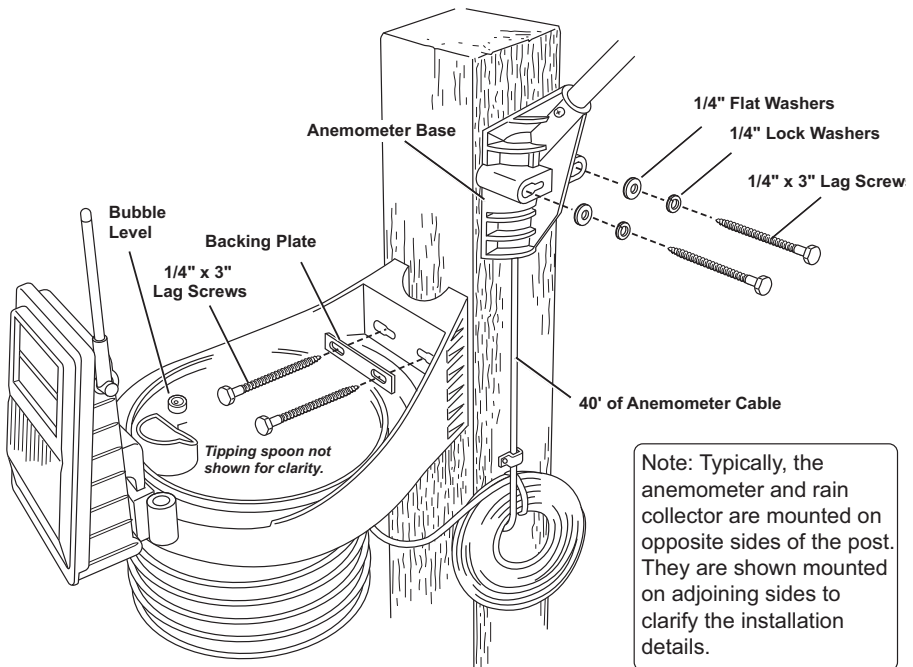

---

### Install the rain collector mounting base:

1. With a 3/16" (5 mm) drill bit, drill two holes approximately 2 1/8" (54 mm) apart. Use a carpenter's level to ensure the holes are level. Use the metal backing plate as a guide when marking the holes.
2. Remove the rain collector cone if it is installed on the sensor suite mounting base.
3. Insert the 1/4" x 3" lag screws through the metal backing plate and the holes in the mounting base into the post. Make sure the sensor suite is level by checking the built-in bubble level.
4. Tighten the lag screws using an adjustable wrench or 7/16" wrench.

### Install the Anemometer

1. With a 3/16" (5 mm) drill bit, drill two holes approximately 2 1/8" (54 mm) apart. Use a carpenter's level to ensure the holes will be level.
2. Insert the 1/4" x 3" lag screws through the flat washers and the holes in the anemometer mounting base into the post.
3. Tighten the lag screws using an adjustable wrench or 7/16" wrench.

---

**Note:** If your anemometer arm cannot be mounted aiming true north, you will need to calibrate the wind direction on your console to display accurate wind directions. See your *Vantage Pro2 Console User Manual*.

---

## Installing the Sensor Suite and Anemometer on a Pole

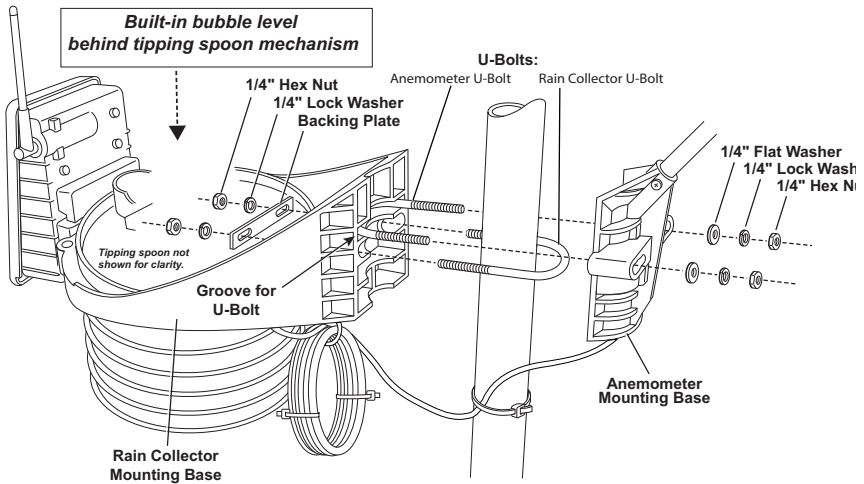

When installing the sensor suite on a pole, the rain collector /radiation shield section of the sensor suite and the anemometer can be mounted together as a single unit, or the two sections can be mounted separately.

---

## Accessories for Pole Mounting

- Use the Mounting Tripod (#7716) for easy mounting, especially on a roof.
- Use the Mounting Pole Kit (#7717) to raise the installation height by up to 37.5" (0.95 m).

## General Guidelines for Installing on a Pole

- With the supplied U-bolts, the sensor suite and anemometer can be mounted on a pole having an outside diameter ranging from 1<sup>1</sup>/<sub>4</sub>" to 1<sup>3</sup>/<sub>4</sub>" (32 – 44mm).
- Larger U-bolts (not supplied) can be used to mount to a pole with a maximum outside diameter of 2<sup>1</sup>/<sub>2</sub>" (64mm).
- To mount on a smaller pole, obtain a U-bolt that fits the sensor suite base openings but that has a shorter threaded section. If mounting on a smaller pole with the included U-bolts, the bolt interferes with the rain collector cone. The pole must be sturdy enough to be stable. Any movement of the pole will affect wind and rain data.
- Use the built-in bubble level to ensure sensor suite is level.

## Guidelines for Installing the Sensor Suite on a Pole

- When mounting the rain collector base and anemometer together on opposite sides of the pole, remember that whichever side is mounted first, the U-bolt from the opposite side must also be placed around the pole before tightening the U-bolts. (If it is not, there is no way to slide it in later.)
- In each side's mounting base, there is a groove to accommodate the other mounting base's U-bolt.
- Once the two sides of the sensor suite have been loosely mounted together on the pole, swivel the unit to the correct direction and then tighten the hex nuts. The desired height can also be achieved by sliding the sensor suite vertically before tightening.

## ***Option 1: Installing the Sensor Suite and Anemometer Together***

Try to install the sensor suite so the anemometer arm is aiming true north.

---

**Note:** If your anemometer arm cannot be mounted aiming true north, you will need to calibrate the wind direction on your console to display accurate wind directions. See your *Vantage Pro2 Console User Manual*.

---

1. Place the U-bolt for the anemometer around the pole so that its round end fits in the top groove on the rain collector mounting base. The groove is right above two large holes.
2. While holding the mounting base of the rain collector against the pole, place the two ends of the remaining U-bolt around the pole and through the two holes in the base.
3. Slide the metal backing plate over the bolt ends as they stick out over the rain collector base. Loosely secure the backing plate with a lock washer and hex nut on each of the bolt ends as shown previously.

---

**Note:** Leave the hex nuts loose to swivel the sensor suite base on the pole.

---



- 
4. The two ends of the anemometer's U-bolt should now be pointing away from the mounted rain collector side. Slide the anemometer's mounting base over the protruding bolt ends. Place a flat washer, a lock washer and a hex nut on each of the bolt ends as shown above. Do not tighten the nuts yet.
  5. Raise the sensor suite unit to the desired height on the pole and swivel it so the anemometer arm is pointing north.
  6. Using an adjustable wrench or 7/16" wrench, tighten all four hex nuts until the sensor suite is firmly fastened on the pole.

### ***Option 2: Installing the Sensor Suite Only***

1. While holding the mounting base against the pole, place the two ends of a U-bolt around the pole and through the two holes in the base.
2. Slide the metal backing plate over the bolt ends as they stick out toward the rain collector cone. Secure the backing plate with a washer, a lock washer, and a hex nut on each of the bolt ends. Do not tighten the nuts yet.
3. For the wireless sensor suite, swivel the sensor suite base so the solar panel is facing south (in the Northern Hemisphere), or north (in the Southern Hemisphere). (Not needed for cabled systems.)
4. Tighten the hex nuts using an adjustable wrench or 7/16" wrench.

### ***Option 3: Installing the Anemometer Only***

1. While holding the mounting base against the pole, place a U-bolt around the pole and through the two holes in the base.
2. Place a flat washer, a lock washer and a hex nut loosely on each of the bolt ends.
3. Swivel the anemometer until the arm is pointing north.
4. Tighten the hex nuts using an adjustable wrench or 7/16" wrench.

---

**Note:** If your anemometer arm cannot be mounted aiming true north, you will need to calibrate the wind direction on your console to display accurate wind directions. See your *Vantage Pro2 Console User Manual*.

---

---

## Finish the Installation

### Close the Transmitter Shelter

1. If the solar panel cable (or the optional fan cable) were disconnected during sensor suite assembly, reconnect them.
2. Find the two raised alignment indicator lines on both the shelter and the cover. Match these alignment indicators as you place the cover against the box.
3. Slide the cover down until it snaps securely in place.

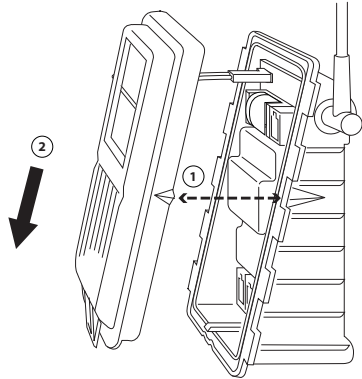

### Re-Attach the Rain Collector

1. Set the cone back on the base so its latches slide downward into the latch openings on the base. Using the finger grips for a secure hold, rotate the cone clockwise until it locks into place.
2. Place the debris screen, pointed end up, into the cone over the funnel hole. Align the locking grooves with the locks inside the cone and turn to lock the screen in place.
3. In some installations, bird droppings can clog the rain collector. To use the bird spikes, insert one spike into each socket around the rim of the cone. The sockets are tapered: push firmly or tap lightly with a hammer for a more secure fit. If you choose not to install the spikes, we recommend that you keep the packet of spikes in case birds become a problem in the future.
4. If bird nesting is a problem, you can place a spike in the hole on the top of the debris screen.

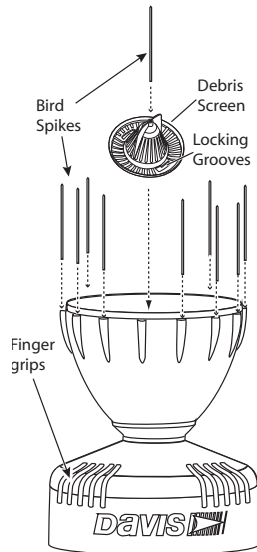

---

**Note:** If your sensor suite has Solar and/or UV sensors, bird spikes around the rim of the rain cone may cast shadows that can affect the accuracy of the sensors and ET readings. For most users, this is less serious than problems caused by birds. To maintain UV and solar accuracy, remove the spikes near the sensors and use the fewest spikes that will deter the birds. For more details and other options, see *Application Note 37: Using Bird Spikes with Solar and/or UV Sensors* on <https://www.davisinstruments.com>.

---

---

## Level the Solar and UV Sensors

If you have an sensor suite that includes a solar radiation and/or UV sensor, use the bubble level on the sensors as a guide to verify that the sensors are level.

Adjust the level by tightening or loosening the three screws that hold each sensor onto the shelf. Make sure that the sensor diffusers are not shaded by the rim of the rain cone.

For the UV sensor, make sure the entire comb structure is above the rim of the rain cone.

For the Solar Radiation sensor, make sure the top of the sensor body is even with or above the rim of the rain cone.

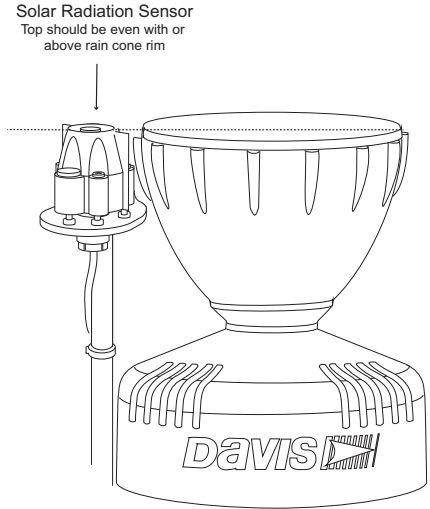

---

**Note:** If you are installing the solar or UV sensors separately, see the Solar Radiation and UV Sensor installation manual for more information.

---

## Start the 24-Hour Fan

If your sensor suite has a 24-Hour Fan-Aspirated Radiation Shield, the batteries are factory installed with plastic tabs between the batteries and the contacts. This prevents batteries from draining during shipping.

The two clear plastic tabs extend out from the largest disk in the radiation shield. Pull them out to start the fan.

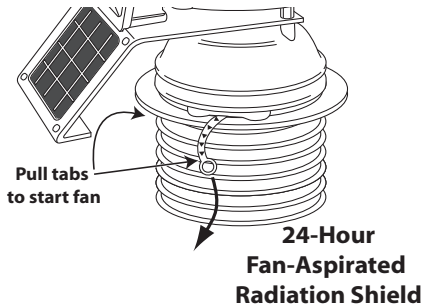

---

**Tip:** If the sensor suite has been in storage for an extended period, the fan batteries may need to charge in sunlight for a few hours.

---

---

## Clear Data Collected During Testing and Installation

Now that the sensor suite is mounted outside, any data that was collected in the Vantage Pro2 console during testing and mounting can be cleared.

1. On the console, press the WIND so that graph icon appears adjacent to the wind data on the display. Confirm that wind speed is displayed on the compass rose.
2. Press and release 2ND, then press and hold CLEAR for at least six seconds and until you see “CLEARING NOW” in the console ticker display.

## Additional Mounting Options

**Add-on Sensors:** Use a Solar- or AC-Powered Sensor Transmitter (#6332 and 6331) to collect data from additional sensors and send it directly to your console, WeatherLink Live or other receiver. Each Sensor Transmitter can support one each of up to five sensors: Anemometer or Sonic Anemometer, Temperature Probe or Temperature/Humidity, Rain Collector, UV, and Solar Radiation. This allows you to install your anemometer remotely or add on a remote temperature station, for example. See “Using Multiple Transmitting Stations” on page 18 for the specific combinations of transmitters and sensors your console and/or WeatherLink Live can receive.

### **Add a Wireless Leaf & Soil Moisture/Temperature Station (#6345):**

See your garden or agricultural data on your console.

**Extend Wireless Transmission Range:** Optional solar-powered repeaters can be used to extend the wireless transmission range. Choose a Standard Wireless Repeater (#7627) or Long-Range Wireless Repeater (#7654).

### **Use Cables for Remote Mounting:**

---

**Note:** Not all cables are compatible with your Vantage Pro2 system. To be sure they will work, order Davis extension cables from your dealer or directly from Davis Instruments.

---

**Cabled Console:** A cabled sensor suite can be extended up to 1000' (300 m) away from the console by using Davis Instruments extension cables (#7876).

**Anemometer:** The anemometer can be extended further than 40' from the sensor suite by using Davis Instruments extension cables (#7876).

Be aware that the maximum measurable wind speed reading decreases as the total length of cable from the anemometer to the sensor suite increases.

---

**Note:** If the cable length is greater than 540' (165m), the maximum measurable wind speed may be less than 100 MPH (161 km/h).

---

**Solar Radiation and UV Sensors:** The solar radiation and UV sensors have a 3' (0.9 m) cable. If you wish to install these sensors away from the sensor suite, you can extend the length of the sensor cables up to 125' (38 m) with Davis Instruments extension cables (#7876).

# Maintenance and Troubleshooting

---

## General Maintenance

You should keep the surfaces of the sensor suite clean, since the radiation shield and solar panels are less effective when dirty. Remove dust from the solar panel and radiation shield with a damp cloth.

Several times a year, inspect the rain collector and radiation shield and remove any debris (such as twigs, leaves, webs and nests) obstructing water flow through the rain collector or air flow through the radiation shield.

At least once a year, or more often in very dusty installations, dismantle and thoroughly clean the radiation shield as described in the following pages.

---

**Tip:** *Before maintaining your sensor suite, avoid recording erroneous data by powering down your console and/or WeatherLink Live.*

---

**Note:** Do not spray the sensor suite with insecticides of any kind. Some insecticides can damage the sensors and even damage the radiation shield.

---

## Maintaining UV and Solar Radiation Sensors

The UV and solar radiation sensors have an outer shell or shield, which protects the sensor body from thermal radiation and provides a path for convection cooling of the body, minimizing heating of the sensor interior. It houses the precision-shaped diffuser, exposed through the top of the shield.

Try not to touch the small white diffusers on top of the sensors. Oil from skin reduces their sensitivity. If you are concerned that you have touched the diffusers at any time, clean with a soft cloth.

Due to the sensitivity of ultraviolet and solar radiation sensors, it is common practice for manufacturers to recommend re-calibration after a period of time. Users demanding high accuracy typically recalibrate their sensors annually. At Davis Instruments, we have seen less than 2% drift per year on the readings from these sensors. Contact Technical Support about returning your sensor for calibration. See “Contacting Technical Support” on page 42.

## Maintaining the Anemometer

The free movement of the wind vane and cups can be inhibited by dust, debris, insects, and spider webs. With an Allen wrench, remove the cups and vane. Remove any dust or debris from the shafts and housing. Turn the shafts the cups and vane rotate on. While the wind direction shaft should have more resistance than the wind cup shaft, if either feels gritty or stiff, contact Davis Technical Support. Reattach the cups and vane and tighten with the Allen wrench.

---

**Note:** Do not lubricate the shaft or bearings in any way. When replacing the cups, make sure they are not rubbing against any part of the anemometer head.

---

---

## Maintaining the Radiation Shield

The outer plating of the radiation shield should be cleaned when there is excessive dirt and build-up on the plating. Wipe the outer edge of each ring with a damp cloth.

---

**Note:** Spraying down or using water excessively to clean the radiation shield can damage the sensitive sensors or alter the data and readings the sensor suite is transmitting.

---

Check the radiation shield for debris or insect nests several times a year and clean when necessary. A buildup of material inside the shield reduces its effectiveness and may cause inaccurate temperature and humidity readings.

At least once a year, thoroughly clean your radiation shield. Follow the instructions below for the correct version of your sensor suite's radiation shield.

---

**Tip:** *You will not need to remove the rain collector base from the pole or post.*

---

### Maintaining a Standard (Passive) Radiation Shield

1. Remove the rain collector cone.
2. Open the transmitter shelter and unplug and remove the temp-humidity cable.
3. While supporting the radiation shield from the bottom, use a Phillips-head screwdriver, to loosen the three 4" (~100mm) screws holding the radiation shield plates together.
4. Taking care to maintain the order in which the five plates are assembled, separate the plates as shown and remove all debris from inside the shield.
5. Inspect and clean any dust or debris from the temperature/humidity sensor inside the shield.
6. Reassemble the plates in the same order in which they were disassembled, and fasten them together using a Phillips-head screwdriver to tighten the 4" screws.
7. Plug the sensor cable in, then replace the foam insert snugly. Check other sensor cables to make sure they are plugged in tightly. If you disconnected the door's solar panel cable, plug it back in.

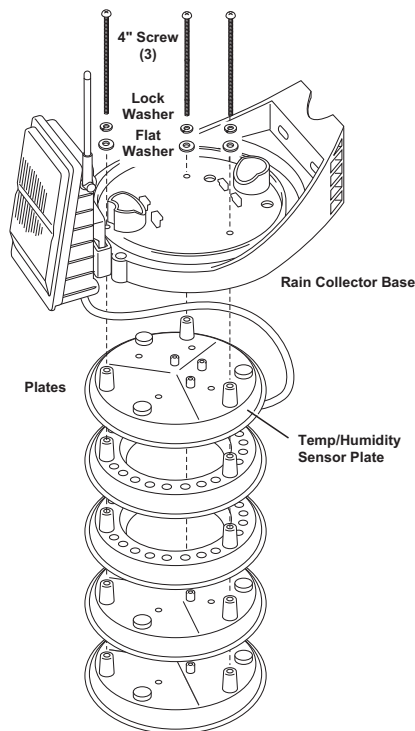

---

**Note:** For some modelsthe order in which the five radiation shield plates are assembled may be slightly different than the order shown in the figure. For this reason, ensure that you always reassemble the plates in the same order in which they were disassembled.

---

---

## Maintaining a 24-Hour Fan-Aspirated Radiation Shield

The cross-section diagram shows how the 24-Hour Fan-Aspirated Radiation Shield draws outside air up through the sensor chamber and between the three walls surrounding the sensor chamber, while the shield stack prevents radiation heating of the outer wall.

To clean it, disassemble the shield and clean interior surfaces as necessary to prevent dirt build up. Check to make sure the fan is running by listening for it, or by holding a piece of tissue paper under the shield. See “24-Hour and Daytime Fans: Replacing the Fan Motor and Batteries” on page 40.

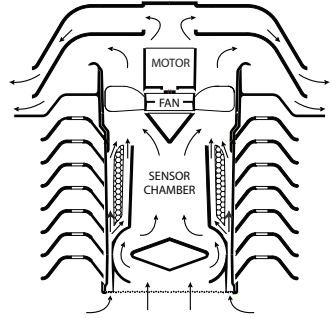

### To thoroughly clean the 24-Hour Fan-Aspirated Radiation shield:

Tools and supplies needed:

- Medium Phillips-head screwdriver (and a small Phillips-head screwdriver if you are also replacing the batteries)
- Adjustable wrench
- Soft, damp cloth
- Soft brush (such as a toothbrush)

You will not need to remove the rain collector base from the pole or post on which it is mounted. You will be able to remove the entire radiation shield so that you can clean it and access the temperature/humidity sensor, the fan, and the fan batteries.

1. Open the transmitter shelter, remove the foam insert and unplug the temperature-humidity cable from the sensor interface. Pull the cable down through the access hole and out of the shelter.

---

**Tip:** *You can also remove the transmitter shelter door by unplugging the solar panel cable. Then you can use the transmitter shelter door to store screws, washers, and spacers as you remove them.*

---

2. Remove the rain collector cone.
3. Using a Phillips-head screwdriver, remove the three screws connecting the rain collector base to the threaded spacers.
4. While removing the screws, support the radiation shield from the bottom. When the screws are removed, it will drop.
5. Take note of the cable placement and routing so you can replace it correctly.

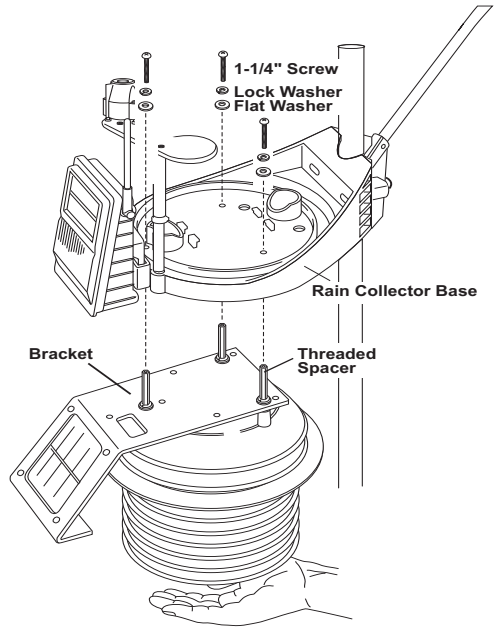

6. Unscrew the three threaded spacers holding the solar panel bracket and radiation shield together and lift off the solar bracket.
7. Remove the two cap plates.

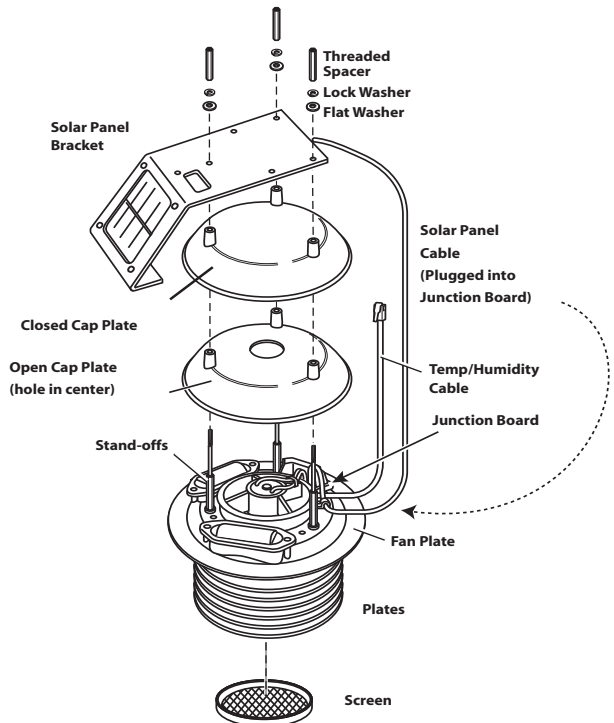



8. Remove the white junction board cover and unplug the fan power cable from the junction board.
9. Lift out the fan and fan and the fan deflector.

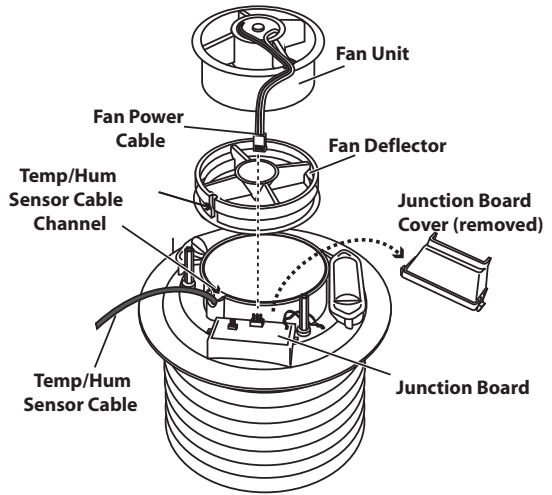

10. Pull the temperature/humidity sensor up and out.
11. Use a soft brush to clean the white plastic and gold mesh of the sensor.
12. Remove all debris from inside the shield and fan and wipe the interior surfaces with a damp cloth.
13. Remove the screen from the bottom of the radiation shield. Wipe it clean, as well as up into the interior of the radiation shield. Replace the screen.
14. Replace the temperature/humidity sensor. It fits one way, into the slots on the side. Route the cable up through the channel and replace the fan deflector with the cable channels correctly aligned with the sensor cable. If a new fan and batteries are needed, See “24-Hour and Daytime Fans: Replacing the Fan Motor and Batteries” on page 40.
15. Replace the fan and plug the fan power cable back into the junction board. The fan should start to rotate.

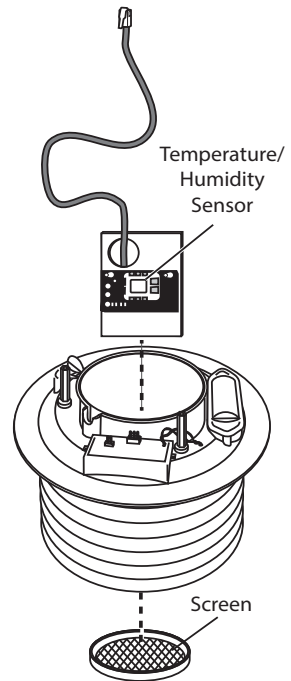

---

Replace the junction board cover.

16. Replace the two cap plates.  
(Note that the closed plate goes on top.) Replace the solar bracket and the threaded spacers, with lock washers and flat washers.

17. Align the threaded spacers with the screws in the rain collector base. Note that cables should exit from the radiation shield toward the mounting pole or post. Screw the screws into the threaded spacers.

18. Route the temperature/humidity cable over the solar bracket and back into the transmitter shelter. Plug it back in, then replace the foam insert snugly. Check other sensor cables to make sure they are plugged in tightly. If you disconnected the door's solar panel cable, plug it back in.

19. Replace the door.

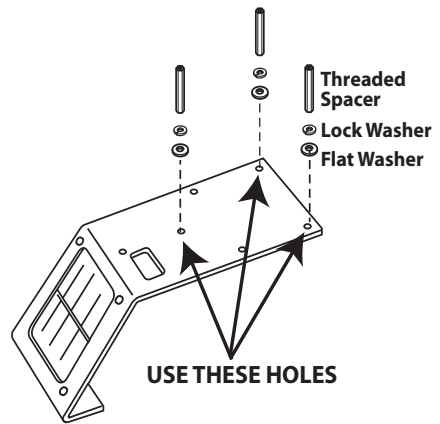

## Daytime Fan-Aspirated Radiation Shield

The Daytime Fan-Aspirated Radiation Shield (#7747) can be added to a standard Vantage Pro2 or Vantage Pro2 Plus. It has a fan that is powered by a solar panel. It differs from the 24-Hour Fan in that it has no batteries. This causes it operate during the daytime when solar radiation effects are of the greatest concern, and to stop at night.

**Tip:** You will not need to remove the rain collector base from the pole or post.

To clean the Daytime Fan Aspirated Radiation Shield

1. Remove the rain collector cone.
2. Open the transmitter shelter and unplug the temp-humidity cable and the fan power cable from the sensor interface.
3. While supporting the radiation shield from the bottom, use a Phillips-head screwdriver to loosen the three screws connecting the rain collector base to the threaded spacers.
4. Lift the rain collector base off the closed and open fan plates. Take note of the cable placement and routing so you can replace it correctly. For easier re-assembly, mark the holes used by the rain collector base and the holes used by the radiation shield.

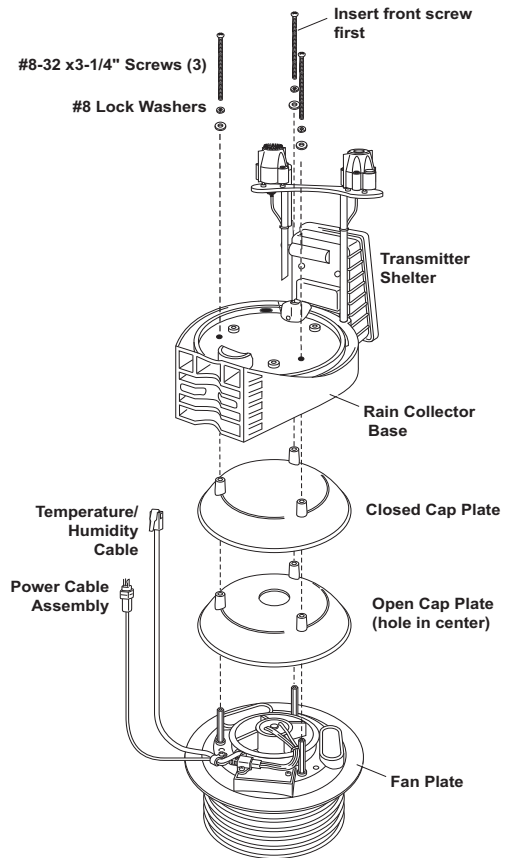

5. Unscrew the three threaded spacers.
6. Remove the three screws from the bottom of the radiation shielding and separate the shield stack, taking care to maintain the order in which the plates are assembled.
7. Remove all debris from inside the shield and wipe the interior surfaces.
8. Plug the fan power cable back into the sensor interface. Expose the solar panel to the sun and make sure the fan rotates. Replace the fan motor as needed. (See below).

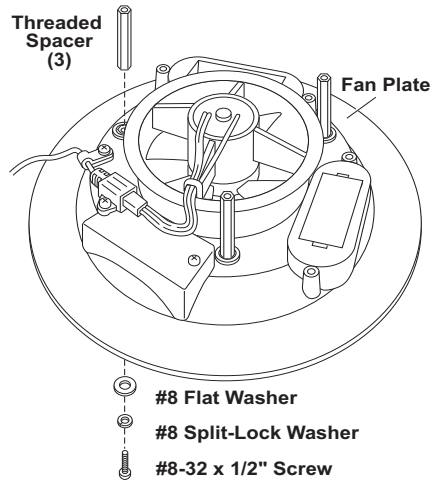

9. Reassemble the radiation shield, routing cables as observed earlier, and plug the temp/humidity cable back into the sensor interface via the access port in the bottom of the shelter. Replace the foam insert and close the transmitter shelter.

### 24-Hour and Daytime Fans: Replacing the Fan Motor and Batteries

To replace the fan motor and batteries in the 24-Hour Fan-Aspirated Radiation Shields, use product no. 7758B: Standard Motor Kit for Fan-Aspirated Radiation Shield with Batteries.

To replace the motor in a Daytime Fan-Aspirated Radiation Shield, use product no. 7758: Standard Motor Kit for Fan-Aspirated Radiation Shield.

1. Unplug the old motor and lift it from the radiation shield.
2. Install the new motor/fan assembly and plug its cable into the junction board.

#### 3. 24-Hour Fan-Aspirated Radiation Shield only:

Remove the battery cover with a Phillips-head screwdriver and remove the old fan batteries.

Install new batteries (NiMH C-cells, included with product number 7758B). Be sure to match the “+” sign on the battery with the “+” sign in the battery compartment.

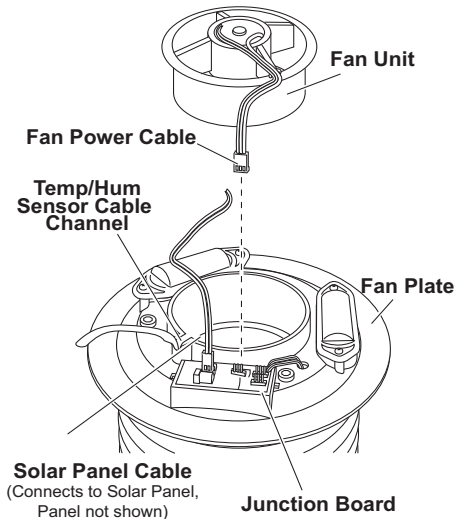

---

## Maintaining the Rain Collector Cone

To maintain accuracy, thoroughly clean the rain collector several times a year.

---

**Note:** Cleaning the rain collector and tipping spoon may cause false rain readings. Unplug the rain sensor from the sensor interface before cleaning so that no inaccurate readings are logged, or clear the weather data that was logged on the Vantage Pro2 console after cleaning is complete. See your *Vantage Pro2 Console User Manual* for instructions on clearing weather data.

---

1. Separate the cone from the base by turning it counter-clockwise.
2. Remove and clean the debris screen.
3. Use a soft, damp cloth to remove any debris from the cone and tipping spoon.
4. Use pipe cleaners to clear the funnel hole in the cone and drain screens in the base.
5. Re-attach the cone and replace the debris screen. (If you unplugged the rain sensor from the sensor interface, be sure to plug it back in.)

## Troubleshooting

### Sensor Functions Intermittently

Carefully check all connections from the sensor to the sensor suite. See “Check the Factory-Installed Sensor Connections” on page 9.

Loose connections account for a large portion of potential problems. Connections should be firmly seated in receptacles and plugged in straight. To check for a faulty connection, try jiggling the cable while looking at the display. If a reading displays intermittently on the console as the cable is jiggled, the connection is faulty. Try removing and then re-installing the cable to correct the faulty connection. If the sensor still functions intermittently contact Technical Support. See “Contacting Technical Support” on page 42.

### Readings Are Not What You Expect

Comparing data from your sensor suite to measurements from the Internet, TV, radio, newspapers, or a neighbor is NOT a valid method of verifying your readings. Readings can vary considerably over short distances. How you site the sensor suite and anemometer can also make a big difference. If you have questions, contact Technical Support.

### Rain Collector Problem

If the rain collector seems to be under-reporting rainfall, remove the rain collector cone to clean the tipping spoon and clear out any debris. Make sure the cable tie around the tipping spoon has been cut and removed.

### Anemometer Problems

*“The wind cups are spinning but my console displays 0 mph.”*

The signal from the wind cups may not be making it back to the display. Check your cables for visible nicks and cuts. Look for corrosion in the WIND connector on the sensor interface and on splices in the cable. If using an extension cable,

---

remove it and test using only the anemometer cable. Contact Technical Support and ask for a wind test cable if the problem has not been resolved.

---

Note: If the anemometer is not sending data, the wind display indicates 0 speed and "--" for direction.

---

*"The wind direction is stuck on north, or displays dashes."*

It is likely that there is a short somewhere between the wind vane and the display. Check the cables for visible nicks and cuts. Look for corrosion in the "WIND" jack on the sensor interface and on splices in the cable (if any). If possible, remove any extensions and try it with the anemometer cable only. If none of these steps get the wind direction working, contact Technical Support and ask for a wind test cable.

*"The wind cups don't spin or don't spin as fast as they should."*

The anemometer may be located where wind is blocked by something, or there may be friction interfering with the cups' rotation. Remove the wind cups (loosen the set screw) and clear out any insects or debris. Turn the shaft the cups rotate on. If it feels gritty or stiff, contact Davis Technical Support.

---

Note: Do not lubricate the shaft or bearings in any way. When replacing the cups, make sure they are not rubbing against any part of the anemometer head.

---

## Contacting Technical Support

For questions about the sensor suite or Vantage Pro2 system, please contact Davis Technical Support. We'll be glad to help.

---

Note: Please do not return items to the factory for repair before calling to get a Return Materials Authorization number.

---

<b>Online</b>	<b><a href="http://www.davisinstruments.com">www.davisinstruments.com</a></b> Find copies of user manuals, product specifications, application notes, software updates, and more.
<b>E-Mail</b>	<b><a href="mailto:support@davisinstruments.com">support@davisinstruments.com</a></b>
<b>Telephone</b>	<b>(510) 732-7814</b> Monday - Friday, 7:00 A.M.- 5:30 P.M., Pacific Time

# Appendix

## Specifications: *Complete specifications on [www.davisinstruments.com](http://www.davisinstruments.com).*

- Temperature range: . . . . . -40 to 150° F (-40 to 65° C)
- Cabled Sensor Suite Power input: . . . . . Console cable from Vantage Pro2 console  
Optional Vantage Pro2 AC power adapter
- Wireless Sensor Suite Primary power: . . . Solar power – Davis solar charger
- Backup power: . . . . . CR-123A 3-volt lithium battery (8 months without  
sunlight- greater than 2 years depending on solar  
charging)

Wireless Sensor Suite frequency range and power output:

REGION	FREQUENCY RANGE & POWER OUTPUT
USA	902 - 928 MHz FHSS, <10mW
EU	868.0 - 868.6 MHz FHSS, <10mW
Australia, Brazil	918 - 926 MHz FHSS, <10mW
India	865 - 867 MHz FHSS, <8mW
New Zealand, Peru	921 - 928 MHz FHSS, <10mW
Japan	928.15 - 929.65 MHz FHSS, <1mW
Taiwan, Pakistan	920 - 925 MHz FHSS, <8mW
Russia	868.7 - 869.2 MHz FHSS, <8mW

- Transmitter ID codes: . . . . . 8 user-selectable
- License: . . . . . Low power (less than 8 mW), no license required

### Sensor Suite Weather Variable Update Intervals (Transmitter ID Dependent)

- Wind speed: . . . . . 2.5 to 3 seconds
- Wind direction: . . . . . 2.5 to 3 seconds
- Accumulated rainfall: . . . . . 20 to 24 seconds
- Rain rate: . . . . . 20 to 24 seconds
- Outside temperature: . . . . . 10 to 12 seconds
- Outside humidity: . . . . . 50 seconds to 1 minute
- Ultraviolet radiation: . . . . . 50 seconds to 1 minute
- Solar radiation: . . . . . 50 seconds to 1 minute

### Fan-Aspirated Radiation Shield

#### 24-Hour Fan

- Aspiration Rate
  - Solar-powered, full sun . . . . . 190 ft./min. (0.96m/s)
  - Battery only . . . . . 80 feet/min (0.4 m/s)
- Radiation Induced Temperature Error . . . . . 0.5°F (0.3°C)  
[At solar noon, insolation = 1040 W/m<sup>2</sup>]  
(Reference: RM Young model 43408)
- Battery Charge/Operating Temperature . . . . . 32° to +113°F (0° to +45°C)
- Battery Discharge/Storage Temperature . . . . . -4° to +140°F (-20° to +60°C)
- Fan Primary Power . . . . . Solar panel
- Fan Secondary Power . . . . . 1 or 2 1.2 Volt NiMH C-cells

#### Daytime Fan

- Radiation Induced Temperature Error . . . . . 1°F (0.5°C)  
[At solar noon, insolation = 1040 W/m<sup>2</sup>]  
(Reference: RM Young model 43408)
- Operating Temperature . . . . . -40° to +150°F (-40° to +65°C)
- Non-operating Temperature . . . . . -50° to +158°F (-45° to +70°C)
- Fan Power . . . . . Solar panel

---

## Sensor Interface

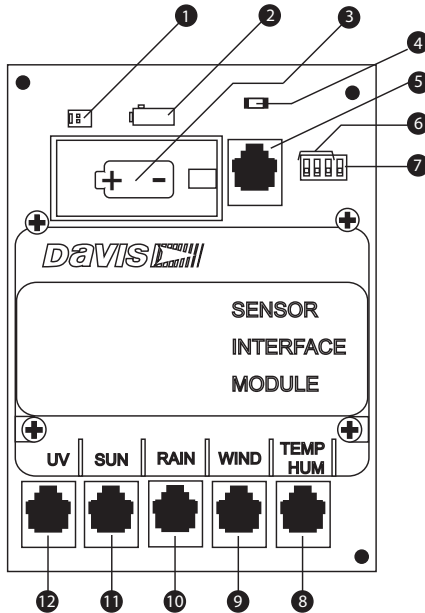

- |                                  |   |
|----------------------------------|---|
| 1 Solar Panel Connector          | 7 Test DIP Switch (wireless only)       |
| 2 AC Adapter Socket              | 8 Temperature/Humidity Sensor Connector |
| 3 Battery Socket (wireless only) | 9 Wind Sensor Connector                 |
| 4 Test LED                       | 10 Rain Sensor Connector                |
| 5 Cabled Connection              | 11 Solar Radiation Sensor Connector     |
| 6 Transmitter ID DIP Switch      | 12 UV Sensor Connector                  |

---

## Vantage Pro2 Integrated Sensor Suite Installation Manual

Document Part Number: 7395.333

Rev N (9/21/22)

For Vantage Pro2 and Vantage Pro2 Plus Weather Stations # 6152, 6152C, 6153, 6162, 6162C, 6163, 6322, 6322C, 6323, 6327, 6327C, 6828, 6329, 6334, 6334C, 6820, 6820C, 6825, 6825C.

Davis®, Davis Instruments®, WeatherLink®, WeatherLink Live™, Vantage Pro®, Weather Envoy™, Vantage Vue® and Vantage Connect® are trademarks of Davis Instruments Corporation, Hayward, CA.

Copyright © 2022 Davis Instruments Corp. All rights reserved. Information in this document subject to change without notice.

Davis Instruments Quality Management System is ISO 9001 certified.



3465 Diablo Avenue, Hayward, CA 94545-2778 U.S.A.

510-732-9229 • info@davisinstruments.com

www.davisinstruments.com