

FAN-ASPIRATED RADIATION SHIELD

For Vantage Pro™ or Vantage Pro Plus™

ADDENDUM TO THE
INTEGRATED SENSOR SUITE
INSTALLATION MANUAL

The Vantage Pro Integrated Sensor Suite (ISS) with the Fan-Aspirated Radiation Shield uses a combination of fan-aspiration and passive shielding to minimize the effects of solar radiation-induced temperature error.

Fan-Aspirated ISS Addendum Overview

This addendum provides additional information specific to the installation and use of the fan-aspirated radiation shield only, and is intended to be used in conjunction with the “Integrated Sensor Suite Installation Manual.”

The table below shows the location of the information required to install and maintain your Fan-Aspirated ISS.

SECTION/PROCEDURE	FAN ASPIRATED ADDENDUM	ISS INSTALLA- TION MANUAL
Tools for Setup		X
Preparing the Anemometer		X
Disassembling the Radiation Shield	X	
Making Junction Board Connections	X	
Powering ISS and Testing Communications		X
Powering and Testing the Fan	X	
Reassembling the Radiation Shield	X	
Preparing the Rain Collector		X
Choosing a Site for the ISS		X
Mounting the ISS		X
Additional Mounting Options		X
Fan-Aspirated ISS Options	X	
Fan-Aspirated ISS Maintenance	X	
Fan-Aspirated ISS Troubleshooting	X	
Fan-Aspirated ISS Specifications	X	

Components

The Fan-Aspirated ISS includes these components:

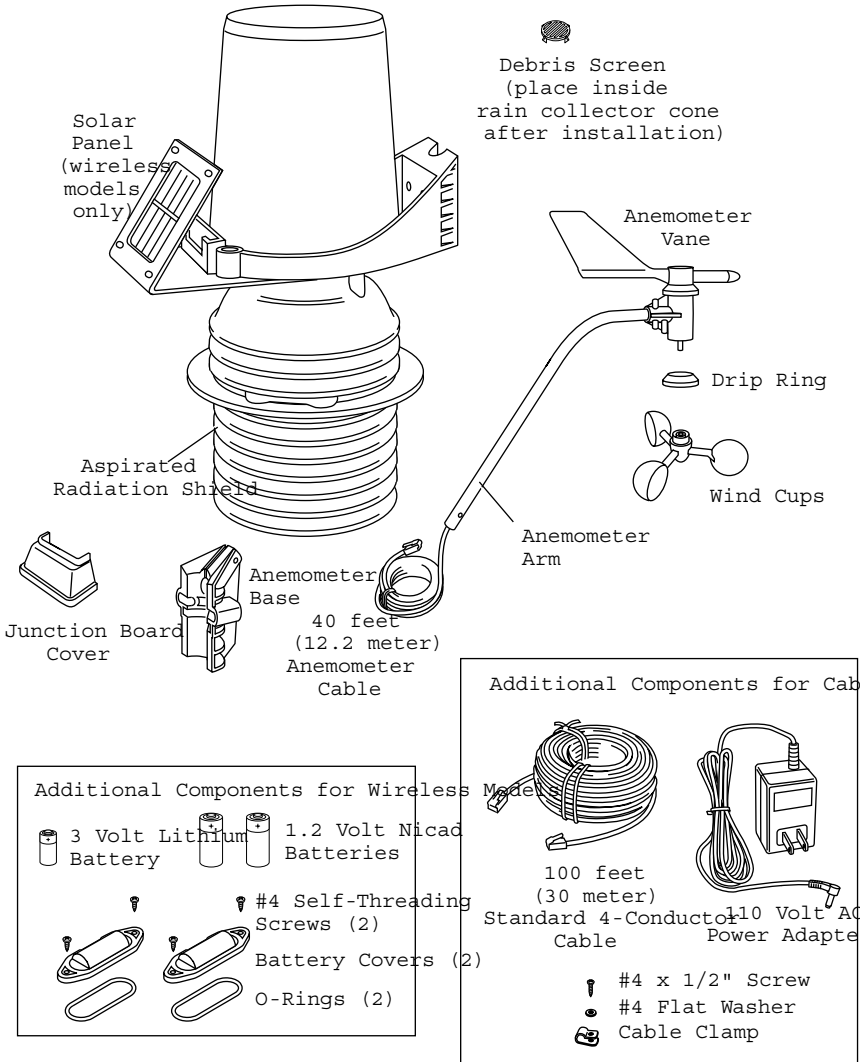

The hardware shown here is provided for assembly and mounting:

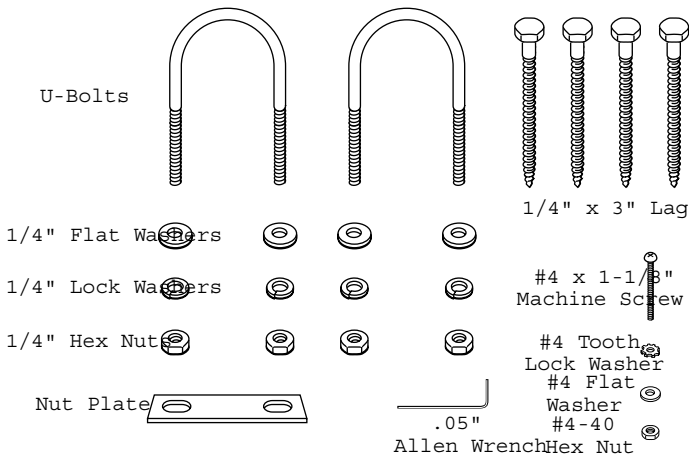

Additional Components on Vantage Pro Plus

Vantage Pro Plus includes an ultraviolet (UV) sensor and a solar radiation sensor. These two sensors are mounted next to the rain collector on your ISS.

Note: Please make every effort when handling your ISS not to touch the small white diffusers on top of the UV and solar radiation sensors. Oil from the skin will reduce their sensitivity. Clean the diffusers using ethyl alcohol on a soft cloth (NOT rubbing alcohol). The solar radiation sensor may also be cleaned with soap and water.

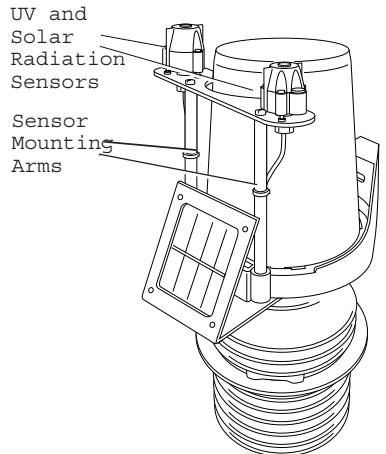

Vantage Pro Plus ISS

Tools for Installation

Refer to this section in your ISS Installation Manual.

Preparing the Anemometer

Refer to this section in your ISS Installation Manual.

Preparing the ISS and Radiation Shield

The radiation shield must be partially disassembled in order to make necessary cable connections, and to install batteries in the solar-powered wireless ISS.

The ISS sensors are connected by cables to the **Sensor Interface Module (SIM)**, located inside the radiation shield. The SIM contains electronics that measure and store weather values for transmission to the console via cable or radio waves. The radiation shield's white plastic plates protect the SIM from sun and other sources of radiated and reflected heat, and from precipitation.

The following tasks are performed while the radiation shield is disassembled:

- ◆ Check the rain, solar radiation, and UV cable connections to the SIM sensor
- ◆ Connect the anemometer sensor cable to the SIM
- ◆ Connect the console cable to the SIM (cabled versions only)
- ◆ Make power connections to the ISS
- ◆ Change the Davis Talk ID for wireless communication, if necessary
- ◆ Verify that your console is receiving and displaying data
- ◆ Power and test the fan

Opening the Radiation Shield

Open up the radiation shield by separating the top and bottom parts as shown in the following illustrations.

1. Turn the rain collector side of the ISS upside down.

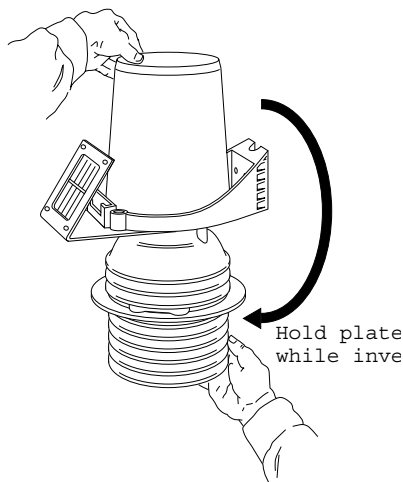

Inverting the ISS

2. Remove the three wing nuts, lock washers and flat washers located on the underside of the radiation shield.

3. Turn the ISS right-side up with the rain collector on top.
4. Hold onto the rain collector and lift off the top part of the ISS, exposing the fan plate on the bottom section of the radiation shield.

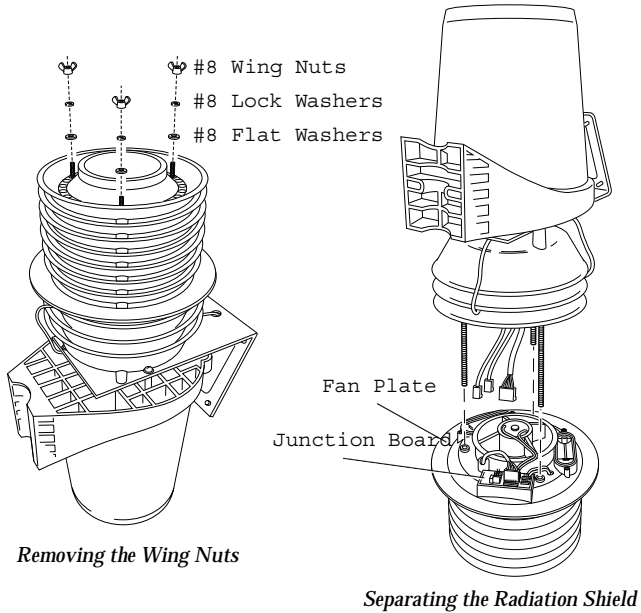

Verifying Sensor Connections:

1. Locate the SIM inside the upper section of the radiation shield.

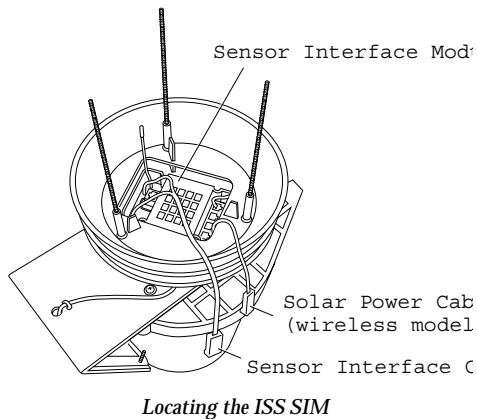

- Verify that the rain sensor cable is plugged into the receptacle labeled "RAIN" on the SIM.

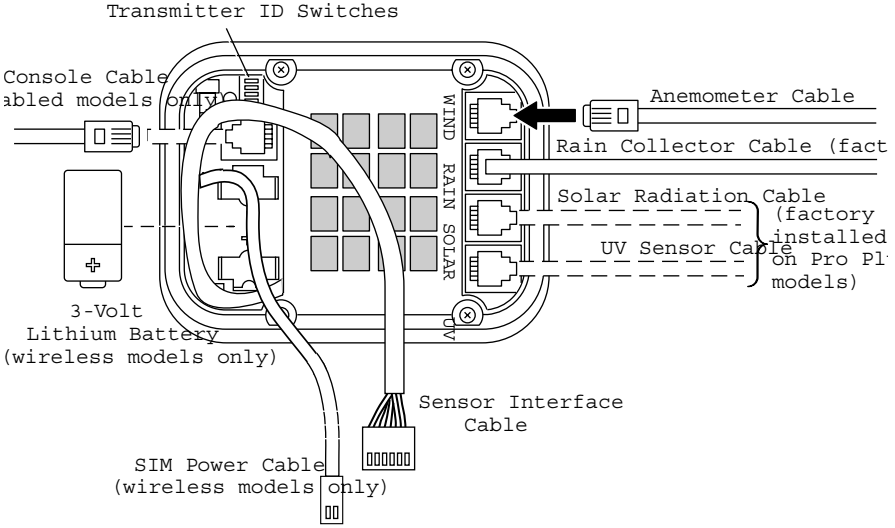

ISS SIM Connections

- If you have a Vantage Pro Plus, verify that the UV and solar radiation sensors are plugged into the SIM.

Connecting Anemometer to SIM

Refer to this section in your ISS Installation Manual.

Cabled Vantage Pro: Powering the ISS and Testing Communication with the Console

Refer to this section in your ISS Installation Manual.

Wireless Vantage Pro: Powering the ISS and Testing Communication with the Console

Refer to this section in your ISS Installation Manual.

Powering the Fan

The Cabled Vantage Pro is powered by an AC-power adapter. The Wireless Vantage Pro ISS is solar-powered with batteries for overnight power. Refer to the Junction Board Connections illustration when powering the fans.

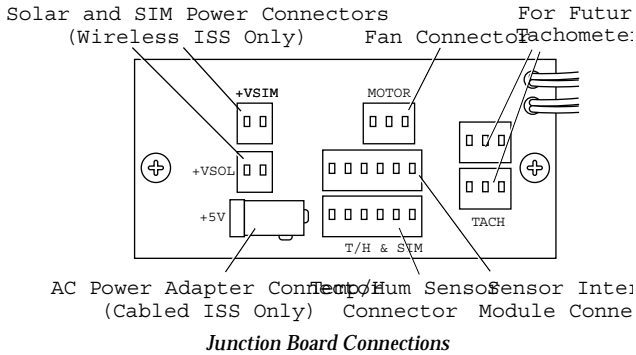

Cabled Vantage Pro

1. Locate the Junction Board on the fan plate (See page 5).
2. Connect the AC-power adapter to the +5V connector on the Junction Board.
3. Plug the AC-power adapter into an AC outlet.
4. Check to see that the fan is blowing air up and away from the Temp/Hum Sensor.
5. Unplug the AC power adapter from the AC outlet until you have finished mounting the ISS.
6. Secure the AC power cable to the fan plate with the supplied cable clip.

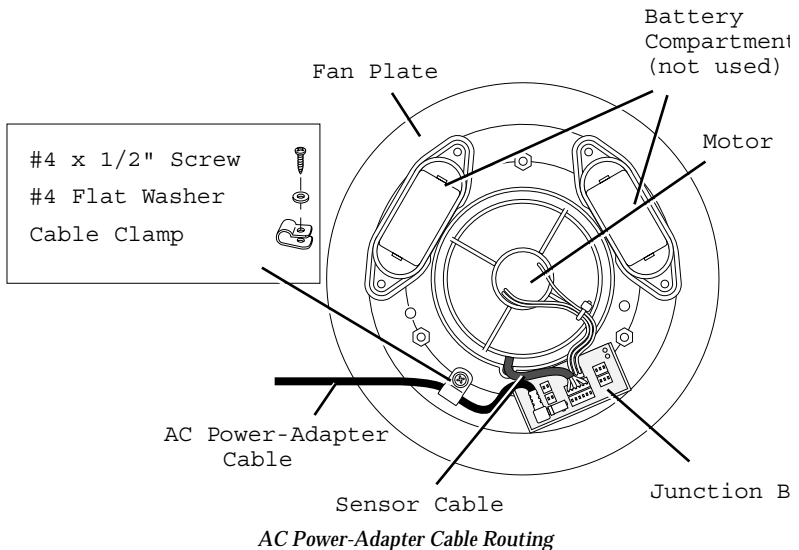

Wireless Vantage Pro

The solar-powered fan on the Wireless ISS will begin operating as soon as you install the batteries. To prevent discharging the batteries, you should only power the fan in a Wireless Vantage Pro immediately before mounting the ISS in its final location.

1. On the Radiation Shield fan plate, insert the O-ring in the groove around the edge of each battery compartment.
2. Insert a NiCad battery in each compartment, matching the plus (+) sign on the battery with the plus (+) sign in the battery compartment.
3. Verify that the fan is blowing air up and away from the Temp/Hum sensor.
4. Attach the battery covers to the battery compartments using two #4 x 3/8" (9.5 mm) screws each.

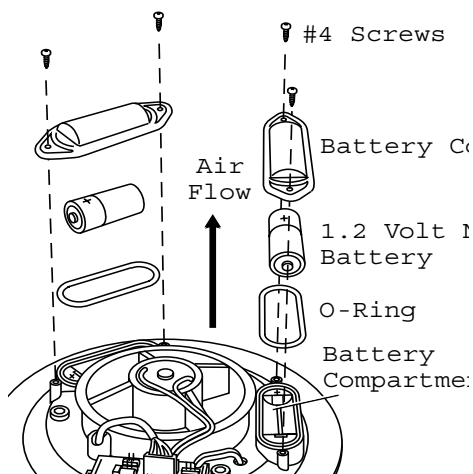

*Installing the Batteries
(Wireless Vantage Pro Only)*

Reassembling the Radiation Shield

1. Make sure the Temp/Hum sensor cable runs through the provided cable channels and that the fan unit is seated on the fan plate.
2. Line up the threaded rods on the upper section of the Radiation Shield with the mounting holes in the lower section.
3. Slide the two sections partially together, leaving enough clearance so that you have access to the Junction Board.

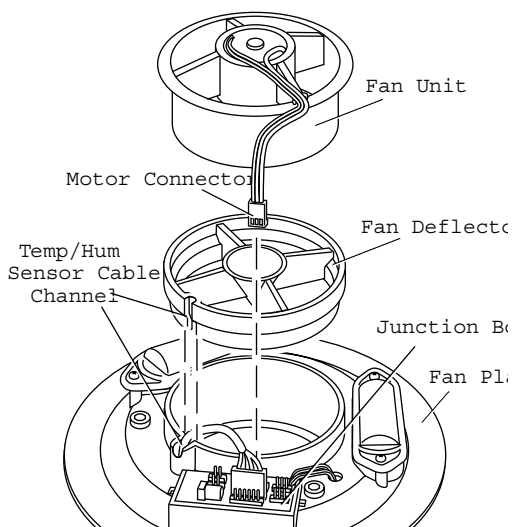

Sensor Cable Channel in Fan Plate and Fan Deflector

4. Check the Junction Board cable connections: SIM Sensor, SIM Power, Motor, Temp/Hum Sensor, and Solar Power. Refer to the figure below and also to the Junction Board Connections figure on page 7.

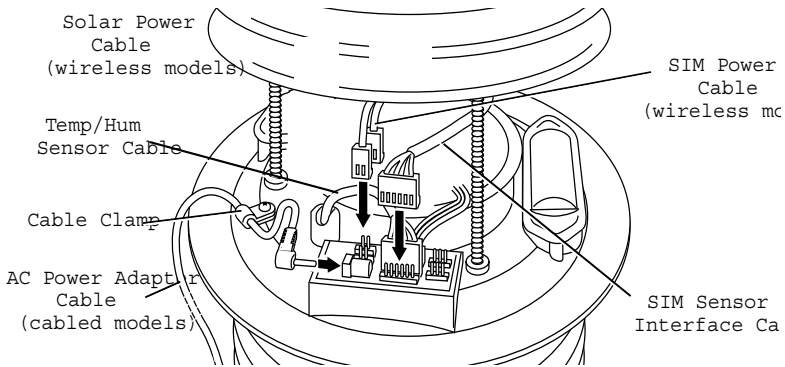

Junction Board Cable Connections

5. Install the Junction Board Cover as show below. The Junction Board Cover presses easily into place when you are installing it. To remove the cover, press gently in on both sides to release the latches holding it in place.

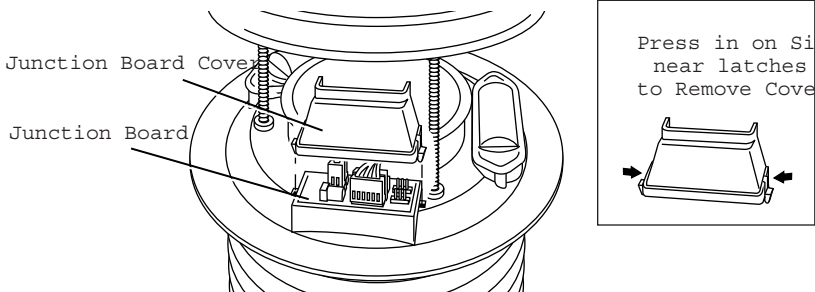

Junction Board Cover Installation

6. Slide the two sections of the Radiation Shield completely together.
7. Place the flat washers, lock washers and plastic wing nuts over the threaded rods.
8. Finger-tighten the wing nuts until they hold the radiation shield plates firmly in place.

Preparing the Rain Collector

Refer to this section in your ISS Installation Manual.

Choosing a Site for the ISS

Refer to this section in your ISS Installation Manual.

Mounting the ISS

Refer to this section in your ISS Installation Manual.

Additional Mounting Options

Refer to this section in your ISS Installation Manual.

Fan-Aspirated ISS Options

Batteries

The Wireless Fan-Aspirated ISS is solar powered and is supplied with two NiCad C-cell batteries. At your option you may decide to install either zero, one, or two C-cell batteries.

- ◆ Install two fan batteries for maximum length of overnight aspiration but with slightly lower average daytime aspiration.
- ◆ Install only one fan battery for some overnight aspiration but with slightly higher average daytime aspiration.
- ◆ Install no batteries for maximum daytime aspiration and no nighttime aspiration.

Low-Current Fan Unit

A low-current fan unit (#7759) is available that uses less power than the standard fan. This allows the solar-powered Fan-Aspirated ISS to run for a longer period of time during darkness. The low-current fan is recommended for use in high latitudes during the Winter months, in climates that experience extended periods of cloudy weather, or for any location with limited solar charging.

Fan-Aspirated ISS Maintenance

- ◆ Keep the surfaces clean as the Fan-Aspirated Radiation Shield is less effective when the surfaces are dirty. Remove dust from the solar panel and the screen with a damp cloth.
- ◆ Remove any debris that obstructs air flow between the radiation shield parts e.g., leaves, twigs, webs, and nests.
- ◆ Avoid spraying insect killer of any kind into the radiation shield as this may damage the sensors and the shield.
- ◆ Once a year: replace the motor (Part # 7758), batteries (solar-powered models only), and remove any debris lodged inside the unit.

Replacing Fan Batteries

1. Retrieve your Fan-Aspirated ISS and place on a stable work surface.
2. Disassemble the Radiation Shield (See page 4).

-
3. Replace the old batteries (See page 8).
 4. Assemble the Radiation Shield (See page 8).
 5. Mount the Fan-Aspirated ISS in the desired location.

Fan-Aspirated ISS Troubleshooting

If you are experiencing problems with your Fan-Aspirated Radiation Shield, first be sure to check all cable connections. If you are unable to solve the problem, please call Davis Technical Support. We'll be glad to help. Most questions can be answered while you're on the phone. You can also email us for support, or visit our website. Sorry, we are unable to accept collect calls.

Note: *Please do not return items to the factory for repair without prior authorization.*

Contacting Davis Instruments

(510) 732-7814 for Technical Support, Monday – Friday, 7:00 a.m. – 5:30 p.m. Pacific Time.

(510) 670-0589 Fax to Customer Service or Tech Support.

www.davisnet.com Copies of User Manuals are available on the “Support” page. Watch for FAQs and other updates. Subscribe to the e-newsletter.

support@davisnet.com E-mail to Technical Support.

Diagram of Operation

The diagram below shows how the Fan-Aspirated Radiation Shield draws cool outside air up through the sensor chamber and through the walls surrounding the sensor chamber.

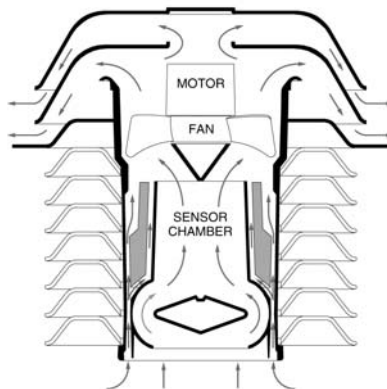

Fan-Aspirated Radiation Shield in Operation

Fan-Aspirated ISS Specifications

Aspiration Rate	215 ft./min. (1.1 m/s) (AC-powered) 190 ft./min (.96 m/s) (solar-powered, typical)
Radiation-Induced Temperature Error	0.5°F (0.3°C) [At solar noon, insolation = 1040 W/m ² (Reference: RM Young model 43408)]

Note: The above error specification is an estimate, based on data from a solar-powered model, with a measured error of 0.6°F at the above conditions and an aspiration rate of 190 ft./min.

Operating Temperature	-40° to +140° F (-40° to +60° C)
Non-operating Temperature	-50° to +158° F (-45° to +70° C)
ISS Primary Power Input	
Wireless ISS	solar panel
Cabled ISS	receives power from Vantage Pro Console
ISS secondary power (Wireless Only)	CR-123A 3-volt lithium battery (approx. two years battery life.)
Fan Primary Power Input	
Wireless ISS	solar panel
Cabled ISS	AC power adapter, 5VDC, 200 mA, regulated
Fan secondary power (Wireless Only)	1 or 2 - 1.2 Volt NiCad C-cells

FCC Part 15 Class B Registration Warning

This equipment has been tested and found to comply with the limits for a class B digital device, pursuant to Part 15 of the FCC Rules. These limits are designed to provide reasonable protection against harmful interference in a residential installation. This equipment generates, uses and can radiate radio frequency energy and, if not installed and used in accordance with the instructions, may cause harmful interference to radio communications. However, there is no guarantee that interference will not occur in a particular installation.

If this equipment does cause harmful interference to radio or television reception, which can be determined by turning the equipment off and on, the user is encouraged to try to correct the interference by one or more of the following measures:

- Reorient or relocate the receiving antenna.
- Increase the separation between the equipment and receiver.
- Connect the equipment into an outlet on a circuit different from that to which the receiver is connected.
- Consult the dealer or an experienced radio/TV technician for help.

Changes or modifications not expressly approved in writing by Davis Instruments may void the user's authority to operate this equipment.

Product Numbers: 6151, 6151C, 6161, 6161C

Davis Instruments Part Number: 7395.152

Fan-Aspirated Radiation Shield Addendum to the Integrated Sensor Suite Installation Manual

Draft Rev B. Manual (8 April 2002)

The term "IC:" before the radio certification number only signifies that Industry of Canada technical specifications were met.

Copyright ©2002 Davis Instruments Corp. All rights reserved.



3465 Diablo Avenue, Hayward, CA 94545-2778

510-732-9229 • Fax: 510-732-9188

E-mail: info@davisnet.com • www.davisnet.com