

GARMIN.

A04560, AA4560, AB4560 SERIES

INSTALLATION INSTRUCTIONS

Important Safety Information

⚠ WARNING

Failure to follow these warnings, cautions, and notices could result in personal injury, damage to the vessel or device, or poor product performance.

See the *Important Safety and Product Information* guide in the product box for product warnings and other important information.

The radar transmits electromagnetic energy. To avoid possible personal injury, damage to the vessel or device, or poor product performance, ensure that the radar is installed according to the recommendations in these instructions and that all personnel are clear of the path of the radar beam before transmitting. When properly installed and operated, the use of this radar conforms to the requirements of ANSI/IEEE C95.1-1992 Standard for Safety Levels with Respect to Human Exposure to Radio Frequency Electromagnetic Fields.

To avoid possible personal injury, do not look directly at the antenna at close range when the radar is transmitting. Eyes are the most sensitive part of the body to electromagnetic energy.

When connecting the power cable, do not remove the in-line fuse holder. To prevent the possibility of injury or product damage caused by fire or overheating, the appropriate fuse must be in place as indicated in the product specifications. In addition, connecting the power cable without the appropriate fuse in place voids the product warranty.

⚠ CAUTION

This device should be used only as a navigational aid. Using the device for any purpose requiring precise measurement or direction, distance, location, or topography may result in personal injury or damage to the vessel.

To avoid possible personal injury, always wear safety goggles, ear protection, and a dust mask when drilling, cutting, or sanding.

Opening the device may result in personal injury and/or damage to the device. This device contains no user-serviceable parts, and should be opened only by a Garmin® authorized service technician. Any damage resulting from opening the unit by anyone other than a Garmin authorized service technician will not be covered by the Garmin warranty.

NOTICE

When drilling or cutting, always check what is on the opposite side of the surface to avoid damaging the vessel.

Software Update

You must update the Garmin chartplotter software when you install this device. For instructions on updating the software, see your chartplotter owner's manual at support.garmin.com.

Tools Needed

- #2 Phillips screwdriver

- 5 mm hex wrench
- Drill and 15.0 mm ($1\frac{9}{32}$ in.) drill bit
- 17 mm ($2\frac{1}{32}$ in.) wrench and torque wrench
- A length of 3.31 mm² (12 AWG) copper wire to ground the radar housing (and voltage converter, if applicable).
- Marine sealant

Mounting Considerations

When selecting a mounting location, observe these considerations.

- It is highly recommended that the device is mounted out of range of people, with the vertical beam width above head height. To avoid exposure to harmful radio frequency (RF) levels, the device should not be mounted closer to people than the maximum safe distance value listed in the product specifications.
- The device should be mounted high above the ship's keel line with minimal blockage of the radar beam. Obstructions may cause blind and shadow sectors or generate false echoes. The higher the installation position, the farther the radar can detect targets.
- The device should be mounted on a flat surface or a platform that is parallel to the vessel's water line and is sturdy enough to support the device's weight. The weight for each model and antenna is listed in the product specifications.
- The device must be mounted in a location where it can be connected to power, water ground, and the Garmin Marine Network (*Wiring and Connection Considerations*, page 3).
- The radar beam spreads vertically 11.5° above and 11.5° below ① the radar's radiating element. On vessels with higher bow angles at cruise speed, the installation angle can be lowered to point the beam slightly downward to the waterline while at rest. Shims can be used if necessary.

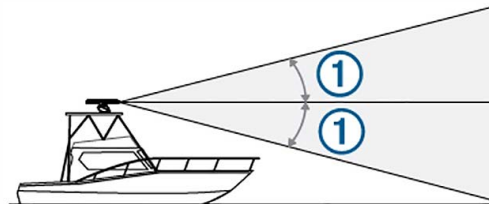

- The device should be mounted away from heat sources, such as smoke stacks and lights.
- The device should be mounted at a different level than horizontal spreaders and mast crosstrees.
- To avoid interference with a magnetic compass, the device should not be mounted closer to a compass than the compass-safe distance value listed in the product specifications.
- Other electronics and cables should be mounted more than 2 m (6.5 ft.) from the radar beam path.
- GPS antennas should be either above or below the radar beam path.
- The device should be mounted at least 1 m (40 in.) from any transmitting equipment.
- The device should be mounted at least 1 m (40 in.) away from cables carrying radio signals such as VHF radios, cables, and antennas.
- The device should be mounted at least 2 m (6.5 ft.) away from Single Side Band (SSB) radios.

Installation Procedures

Preparing the Surface and the Radar for Mounting

Before you can mount the radar, you must choose a suitable mounting location (*Mounting Considerations, page 1*).

- 1 Secure the included mounting template to the surface at the mounting location, along the bow-stern axis, as indicated on the template.
- 2 Drill the mounting holes using a 15 mm ($19/32$ in.) drill bit.
- 3 If you need to run the power and network cables through the mounting surface, select a location under the power and network connectors indicated on the template, drill a pass-through hole for the cables using a 32 mm ($1\frac{1}{4}$ in.) drill bit, and route the cables through the surface (optional) (*Wiring and Connection Considerations, page 3*).
- 4 Remove the mounting template from the surface.
- 5 Remove the hatch on the front of the pedestal by loosening the screw and lifting the hatch off of the hinges.

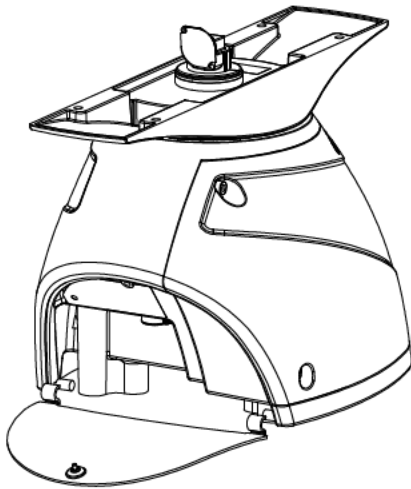

- 6 Apply the included Petrolatum Primer to one half of the threads of the four threaded rods.
- 7 Insert the ends of the threaded rods coated in Petrolatum Primer into the pedestal.
- 8 Tighten the threaded rods using a 5 mm hex wrench. To avoid damaging the pedestal, you should stop tightening the threaded rods when they no longer turn easily.

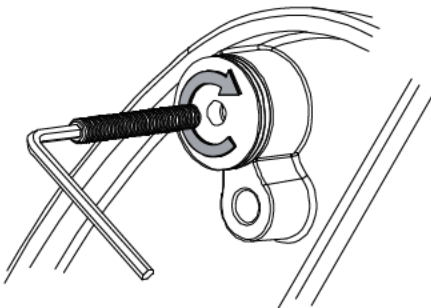

Mounting the Radar

Before you can mount the radar, you must first select a mounting location, and prepare the mounting surface and the radar (*Preparing the Surface and the Radar for Mounting, page 2*).

- 1 Take note of which end of the pedestal you plan to mount facing the bow along the bow-stern axis. If the hatch side is facing the bow, you must adjust the front-of-boat offset on the chartplotter to receive an accurate radar reading (*Front-of-Boat Offset, page 4*).

- 2 Hoist the radar into position, and carefully lower it onto the mounting surface, feeding the threaded rods through the holes.
- 3 From under the mounting surface, place the shoulder washers ① on the threaded rods and feed them into the mounting surface so they fit securely.

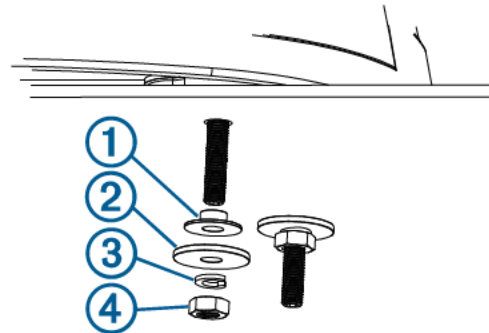

- 4 Place the flat washers ②, lock washers ③, and hex nuts ④ on the threaded rods.
- 5 Torque the hex nuts to 1.5 kgf-m (130 lbf-in. [11 lbf-ft.]) to securely fasten the radar to the surface without damaging the radar or the mounting hardware.

Installing the Antenna

Before you can install the antenna on the radar, you must securely mount the pedestal (*Mounting the Radar, page 2*).

- 1 Remove the protective cover ① from the waveguide on the top of the pedestal.

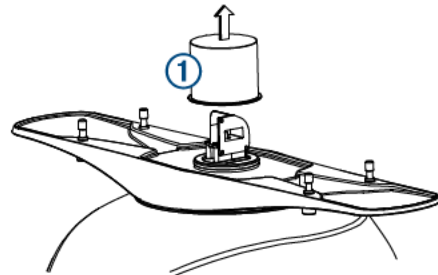

- 2 Align the waveguide ② on the pedestal with the socket on the bottom of the antenna ③, and slide the antenna onto the pedestal.

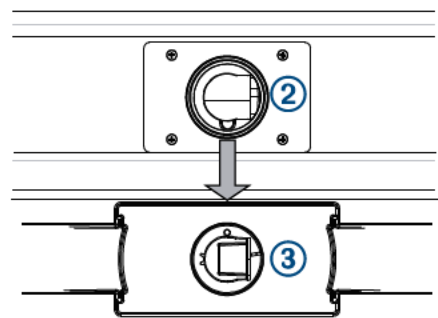

- 3 Secure the antenna to the pedestal using the included hex bolts ④ and spring washers ⑤.

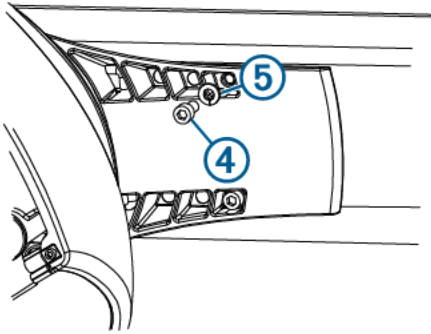

- 4 Torque the hex bolts to 0.81 kgf-m (70 lbf-in. [6 lbf-ft.]) to fasten the antenna to the pedestal without damaging the antenna or the mounting hardware.

Wiring and Connection Considerations

It may be necessary to drill 32 mm (1¼ in.) holes for routing the power, network, or grounding cables.

- When routing multiple cables through the same hole, you must route the network cable before the power and ground cables because of the size of the network connector.
- You must apply marine sealant to the hole after the cables are in place to ensure a waterproof seal.

If you must make the routing hole in a visible location, decorative cable grommets can be purchased from Garmin or a Garmin dealer (optional).

- If needed, you can trim the grommet to enable you to route multiple cables through the same hole.
- The optional grommet does NOT provide a waterproof seal. You must apply marine sealant to the grommet after the cables are in place to ensure a waterproof seal.

When installing the cables, you should observe these considerations.

- Cutting the Garmin Marine Network cable is not recommended, but a field install kit can be purchased from Garmin or a Garmin dealer if you must cut the network cable.
- The ground cable is not included, and must connect to a water ground location, not the negative terminal of the battery ([Grounding the Radar, page 4](#)).
- To ensure safety, appropriate tie-wraps, fasteners, and sealant should be used to secure the cable along the route and through any bulkheads or the deck.
- You should not run cables near moving objects and high-heat sources, or through doorways and bilges.
- To avoid interference with other equipment, you should not run network and power cables parallel to other cables, such as radio antenna lines or power cables. If this is not possible, the cables should be shielded with metal conduit or a form of EMI shielding.
- You should install the power cable as close to the battery source as possible.
 - If it is necessary to extend the power cable, you must use the appropriate wire gauge ([Power Cable Extensions, page 4](#)).
 - Incorrectly extended runs of cable may cause the radar to malfunction due to insufficient power transmission.

Connecting to Power Through the Voltage Converter

⚠ WARNING

When connecting the power cable, do not remove the in-line fuse holder. To prevent the possibility of injury or product damage caused by fire or overheating, the appropriate fuse must be in place as indicated in the product specifications. In

addition, connecting the power cable without the appropriate fuse in place voids the product warranty.

NOTICE

Do not reuse any voltage converters from previous Garmin radar models, or third party voltage converters. Using any converter other than one included with the radar may damage the radar or prevent it from turning on.

Some radar models require a voltage converter unit to properly power the device. If your model is packaged with a voltage converter, it must be installed in order for your radar to function. If your model is not packaged with a voltage converter, connect the power cable directly to the boat battery ([Connecting Directly to Power, page 3](#)).

When installing the voltage converter for an applicable radar model, observe these considerations.

- The voltage converter requires an input voltage of 11 to 32 Vdc for 4kW. 10-32 for 12/25kW.
- It is recommended to install the voltage converter as close as possible to the power source.
- Connecting the power cable for the voltage converter directly to the battery is recommended. If it is necessary to extend the cable, the appropriate gauge of wire must be used for the length of the extension ([Power Cable Extensions, page 4](#)).

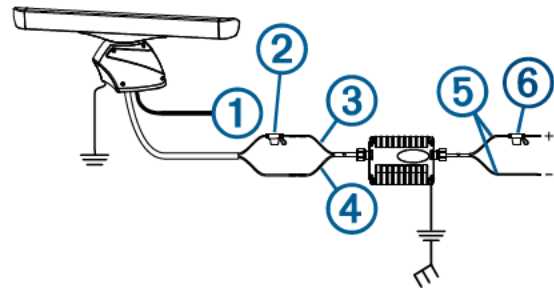

Item	Description
①	To the Garmin Marine Network
②	10 A fuse holder
③	Red (+)
④	Black (-)
⑤	To the boat battery (11 to 32 Vdc 4kW, 10-32Vdc 12/25kW)
⑥	30 A fuse holder
⊥	Water ground connection

- 1 Route the power cable to the radar and the voltage converter.
- 2 Use crimp connectors and heat-shrink tubing to connect the power cable to the voltage converter.

The radar power cable contains a 10 A fuse which should not be removed when connecting to the voltage converter.
- 3 Connect the voltage converter to the boat battery through the included 30 A fuse.

The 30 A fuse between the voltage converter and battery is in addition to the 10 A fuse included in the radar power cable. Both fuses must be in place for the radar to function properly.
- 4 Connect the power cable to the POWER port on the radar.

Connecting Directly to Power

⚠ WARNING

When connecting the power cable, do not remove the in-line fuse holder. To prevent the possibility of injury or product damage caused by fire or overheating, the appropriate fuse must be in place as indicated in the product specifications. In

addition, connecting the power cable without the appropriate fuse in place voids the product warranty.

Some radar models do not require a voltage converter unit. If your model is packaged without a voltage converter, it should be connected directly to power.

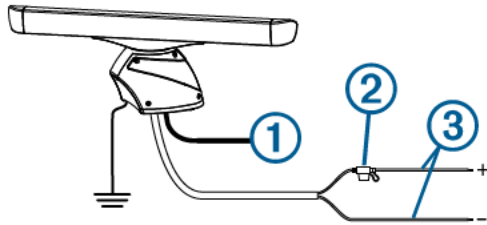

Item	Description
①	To the Garmin Marine Network
②	15 A fuse holder
③	To the boat battery (11 to 32 Vdc 4kW, 10-32Vdc 12/25kW)
⊕	Water ground connection

- 1 Route the power cable to the radar and boat battery.
- 2 Connect the power cable to the boat battery.
- 3 Connect the power cable to the POWER port on the radar.

Power Cable Extensions

Connecting the power cable directly to the battery is recommended. If it is necessary to extend the cable, the appropriate gauge of wire must be used for the length of the extension.

You must use crimp connectors and heat-shrink to create a water-resistant connection.

Distance	Wire Gauge
3 m (9 ft. 10 in.)	3.31 mm ² (12 AWG)
5 m (16 ft. 4 in.)	5.26 mm ² (10 AWG)
6.5 m (21 ft. 3 in.)	6.63 mm ² (9 AWG)
8 m (26 ft. 2 in.)	8.36 mm ² (8 AWG)

Grounding the Radar

The radar (and voltage converter, if applicable) must be connected to the appropriate type of ground using a 3.31 mm² (12 AWG) copper wire (not included).

- 1 Route a 3.31 mm² (12 AWG) copper wire to a water ground location and to the radar pedestal.
- 2 Connect the wire to the ground connector on the pedestal (⊕) using the pre-installed crimp connector.

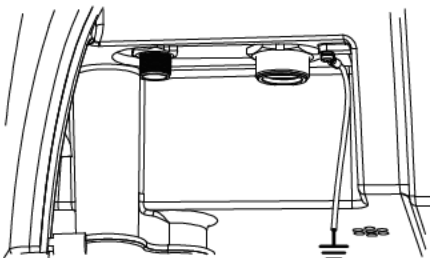

- 3 Coat the ground screw and crimp connector with marine sealant.
- 4 Connect the other end of the wire to the water ground location on the boat, and coat the connection with marine sealant.
- 5 Select an option:
 - If your radar was not packaged with a voltage converter, no further grounding is necessary.

- If your radar was packaged with a voltage converter, proceed to step 6.

- 6 Route a different 3.31 mm² (12 AWG) copper wire to water ground location and to the voltage converter.
- 7 Loosen a screw on one corner of the voltage converter and secure the copper wire to the screw.
- 8 Coat the screw and wire on the voltage converter with marine sealant.
- 9 Connect the other end of the wire to the RF ground location on the boat, and coat the connection with marine sealant.

Garmin Marine Network Considerations

This device connects to Garmin Marine Network devices to share radar data with compatible devices on the network. When connecting to a Garmin Marine Network device, observe these considerations.

- A Garmin Marine Network cable must be used for all Garmin Marine Network connections.
 - Third-party CAT5 cable and RJ45 connectors must not be used for Garmin Marine Network connections.
 - Additional Garmin Marine Network cables and connectors are available from your Garmin dealer.
- Although it is not recommended, you can use a field-installable connector to create a custom-length Garmin Marine Network cable if necessary. Follow the directions provided with the connector.

Radar Operation

All functions of this radar are controlled with your Garmin chartplotter. See the Radar section of your chartplotter's owner's manual for operating instructions. To download the latest manual, go to support.garmin.com.

If you have more than one radar on your boat, you must be viewing the radar screen for the radar you want to configure.

Specifying the Antenna Size

Before you can use the radar on your system, you must specify the antenna size.

- 1 Turn on the radar and all devices connected to the Garmin Marine Network.

An antenna-selection prompt appears on the connected chartplotters.

NOTE: If the entire system is being turned on for the first time, the antenna-selection screen is part of the initial setup process.

- 2 Select the installed antenna size for each open-array radar installed on the boat.

TIP: If you need to specify a different antenna size, while viewing the radar screen for the radar you want to change, select **Menu > Radar Setup > Installation > Antenna Configuration > Antenna Size**, and select the antenna size.

Front-of-Boat Offset

The front-of-boat offset compensates for the physical location of the radar scanner on a boat, if the radar scanner does not align with the bow-stern axis.

Measuring the Potential Front-of-Boat Offset

The front-of-boat offset compensates for the physical location of the radar scanner on a boat, if the radar scanner does not align with the bow-stern axis.

- 1 Using a magnetic compass, take an optical bearing of a stationary target located within viewable range.
- 2 Measure the target bearing on the radar.
- 3 If the bearing deviation is more than +/- 1°, set the front-of-boat offset.

Setting the Front-of-Boat Offset

Before you can set the front-of-boat offset, you must measure the potential front-of-boat offset.

The front-of-boat offset setting configured for use in one radar mode is applied to every other radar mode and to the Radar overlay.

- 1 From a Radar screen or the Radar overlay, select **Menu > Radar Setup > Installation > Front of Boat**.
- 2 Select **Up** or **Down** to adjust the offset.

Setting a Custom Park Position

By default, the antenna is stopped perpendicular to the pedestal when it is not spinning. You can adjust this position.

- 1 From the radar screen, select **Menu > Radar Setup > Installation > Antenna Configuration > Park Position**.
- 2 Use the slider bar to adjust the position of the antenna when stopped, and select **Back**.

Specifications

Specification	Measurement
Pedestal weight	23.2 kg (51.2 lb.)
Antenna weight	4 ft. antenna: 5.5 kg (12.2 lb.) 6 ft. antenna: 7.7 kg (16.9 lb.)
Power cable length	15 m (49 ft. 3 in.)
Network cable length	15 m (49 ft. 3 in.)
Antenna rotation speed	24 rpm and 48 rpm
Maximum wind load	100 kn
Temperature range	AB4560: From -15 to 70°C (from 5 to 158°F) A04560: From -15 to 60°C (from 5 to 140°F)
Humidity	95% at 35°C (95°F)
Water rating	IEC 60529 IPX6 (protected against heavy seas)
Bearing accuracy	0.25 degrees
Input voltage	11 to 32 Vdc 4kW, 10-32Vdc 12/25kW
Fuse	Radar power cable, no voltage converter: 15 A Radar power cable, with voltage converter (if applicable): 10 A Voltage converter (if applicable): 30 A
Input power AB4560	• Typical: 55 W • Max.: 160 W
	•

Specification	Measurement
Input power A4560	• Typical: 90 W • Max.: 125 W
Input power A04560	• Typical: 100 W • Max.: 180 W
Pulse width	For pulse width information, go to the specifications tab for your radar model on garmin.com .
Compass-safe distance	Standard compass: 78.74 cm (31 in.) Standby steering and emergency compasses: 78.74 cm (31 in.)

Antenna Specifications

Specification	Measurement
Type	End-fed slotted waveguide
Horizontal beam width	4 ft. antenna: 1.8 degrees 6 ft. antenna: 1.1 degrees
Horizontal side lobes	-23 dB within ±10 degrees of main -30 dB outside ±10 degrees of main
Vertical beam width	23°
Antenna gain	4 ft. antenna: 27 dB 6 ft. antenna: 29 dB
Polarization	Horizontal

Minimum Safe Operating Distances

When it is transmitting, the radar should be located in a position on the vessel that is at least this far from people. IEC 60936-1, clause 3-27.1, specifies the maximum distances from the antenna at which radio frequency (RF) levels can be expected. These minimum safe distances apply for a transmitting radar with a rotating antenna, and are much larger when the antenna is not rotating. If rotation of the antenna is obstructed for any reason, the transmitter will automatically turn off.

Model	100 W/m ² HD3	50 W/m ²	10 W/m ²
AB4560	0.09 m (3.54 in.)	0.13 m (5.11 in.)	0.28 m (11.02 in.)
AB4560	0,09 m (3,54 in.)	0,13 m (5,11 in.)	0,30 m (11,81 in.)
A A4560	0.15 m (5.91 in.)	0.22 m (8.66 in.)	0.49 m (19.29 in.)
A A4560	0.16 m (6.30 in.)	0.23 m (9.06 in.)	0.51 m (20.08 in.)
A04560	0.16 m (6.30 in.)	0.22 m (8.66 in.)	0.50 m (19.69 in.)
A04560	0,17 m (6,69 in.)	0,23 m (9,06 in.)	0,52 m (20,47 in.)

Dimensions

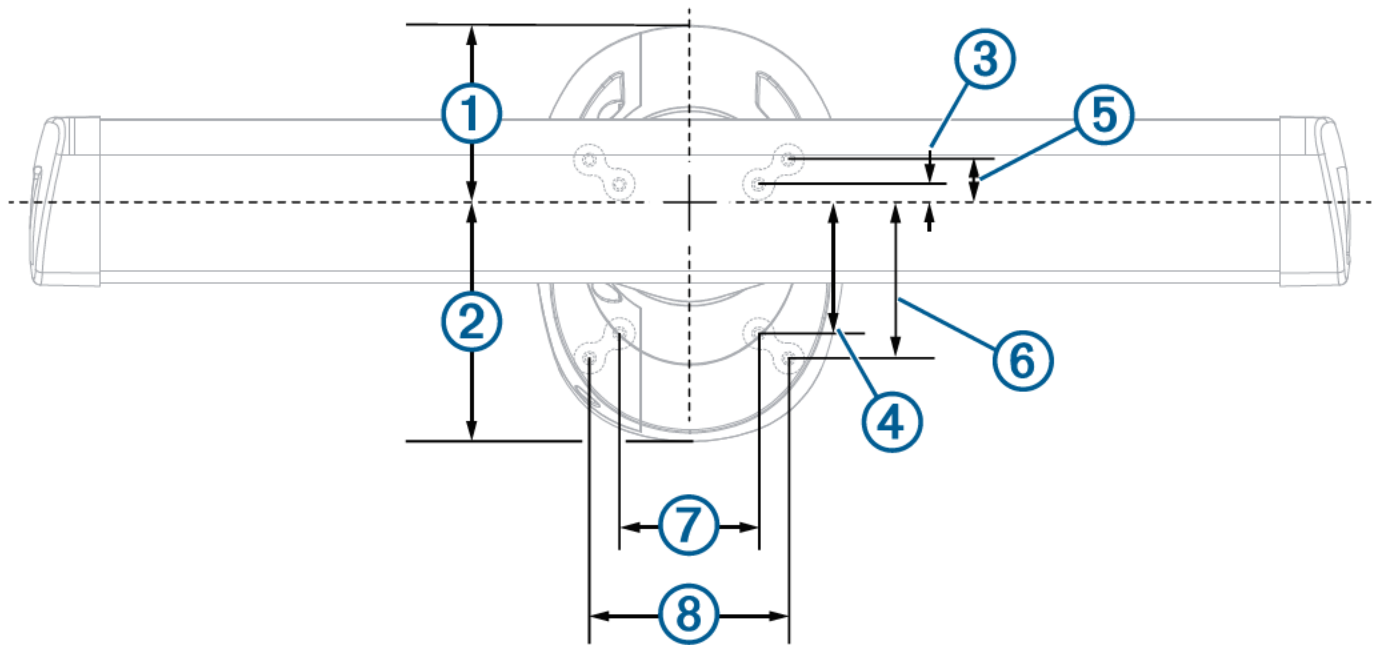

Item	Measurement	Description
①	181.8 mm (7 ³ / ₁₆ in.)	Center of rotation to the rear of the pedestal.
②	236.2 mm (9 ⁵ / ₁₆ in.)	Center of rotation to the front of the pedestal.
③	25 mm (1 in.)	Center of rotation to the inner rear mounting holes.
④	125 mm (4 ¹⁵ / ₁₆ in.)	Center of rotation to the inner front mounting holes.
⑤	50 mm (1 ¹⁵ / ₁₆ in.)	Center of rotation to the outer rear mounting holes.
⑥	150 mm (5 ²⁹ / ₃₂ in.)	Center of rotation to the outer front mounting holes.
⑦	140 mm (5 ¹ / ₂ in.)	
⑧	200 mm (7 ⁷ / ₈ in.)	

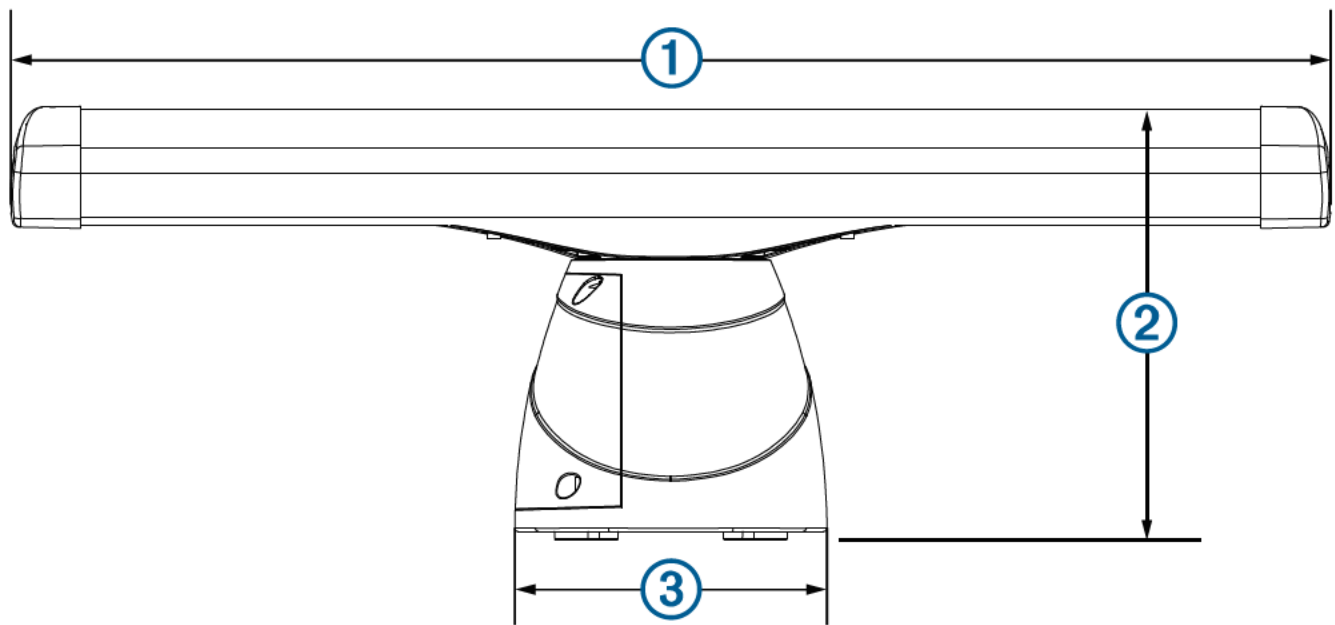

Item	Measurement	Description
①	4 ft. models: 132.7 cm (4 ft. 4 1/4 in.) 6 ft. models: 193.7 cm (6 ft. 4 1/4 in.)	Antenna length.
②	45.1 cm (17 3/4 in.)	Base of the pedestal to the top of the antenna.
③	31.8 cm (12 1/2 in.)	Width of the pedestal.

Open-Source Software License

To view the open-source software license(s) used in this product, go to developer.garmin.com/open-source/linux/.

Installation Troubleshooting

Symptom	Possible Causes
The radar does not turn on. The status LED is not on.	<ul style="list-style-type: none"> The power cable may not be connected correctly to the device or to the battery. Check all connections. The inline fuse may have blown. Check the fuse and replace it if necessary. The wire gauge used to extend the power cable may be too small for the length of the extension. Check the table provided in the Power Cable Extensions section of these instructions to make sure the correct wire gauge is used (<i>Power Cable Extensions, page 4</i>). If the radar uses a voltage converter, it may be connected through an incompatible or third-party voltage converter. Use only the voltage converter supplied with the radar.
The radar is not available on the Garmin device or on devices connected to the Garmin Marine Network.	<ul style="list-style-type: none"> The radar may not be powering on. Check the status LED. The device software may not be up-to-date. Update the software on the device or on the Garmin Marine Network. The network cable may not be connected correctly to the device or to the Garmin Marine Network. Check all connections. If a field-installable network connector was used, it may have been installed improperly. Check the connector.

The status LED is located on the product label, and can help troubleshoot installation problems.

Status LED Color and Activity	Radar Status
Solid red	The radar is getting ready for use. This should only stay red briefly before changing to flashing green.
Flashing green	The radar is operating properly.
Flashing orange	The radar software is being updated.
Flashing red	The radar has encountered an error. Contact Garmin product support for assistance.

Contacting Garmin Support

- Go to support.garmin.com for help and information, such as product manuals, frequently asked questions, videos, and customer support.
- In the USA, call 913-397-8200 or 1-800-800-1020.
- In the UK, call 0808 238 0000.
- In Europe, call +44 (0) 870 850 1241.

© 2016 Garmin Ltd., or its subsidiaries

Garmin® and the Garmin logo are trademarks of Garmin Ltd. or its subsidiaries, registered in the USA and other countries. GMR™ is a trademark of Garmin Ltd. or its subsidiaries. These trademarks may not be used without the express permission of Garmin.

Compliance Notice:

English:

This device contains licence-exempt transmitter(s)/receiver(s) that comply with Innovation, Science and Economic Development Canada's licence-exempt RSS(s). Operation is subject to the following two conditions:

- This device may not cause interference.
- This device must accept any interference, including interference that may cause undesired operation of the device.

French:

Cet appareil contient un ou des émetteurs/récepteurs exempts de licence conformes aux RSS exempts de licence d'Innovation, Sciences et Développement économique Canada. Le fonctionnement est soumis aux deux conditions suivantes :

- Cet appareil ne doit pas causer d'interférences.
- Cet appareil doit accepter toute interférence, y compris les interférences pouvant entraîner un fonctionnement indésirable de l'appareil.

