

FCC Test Report

FCC ID : IPH- A03460
Equipment : Marine Stereo
Model No. : A03460
Brand Name : FUSION
Applicant : Garmin International, Inc.
Address : 1200 E. 151st Street Olathe, KS 66062 United States
Standard : 47 CFR FCC Part 15.247
Received Date : Oct. 07, 2021
Tested Date : May 02 ~ May 09, 2022

We, International Certification Corporation, would like to declare that the tested sample has been evaluated and in compliance with the requirement of the above standards. The test results contained in this report refer exclusively to the product. It shall not be reproduced except in full without the written approval of our laboratory.

Reviewed by:

Approved by:

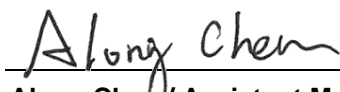

Along Chen / Assistant Manager

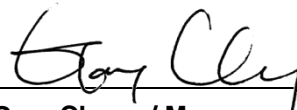

Gary Chang / Manager

Table of Contents

1	GENERAL DESCRIPTION	5
1.1	Information.....	5
1.2	Local Support Equipment List	8
1.3	Test Setup Chart	8
1.4	The Equipment List	9
1.5	Test Standards	10
1.6	Reference Guidance	10
1.7	Deviation from Test Standard and Measurement Procedure.....	10
1.8	Measurement Uncertainty	10
2	TEST CONFIGURATION.....	11
2.1	Testing Facility	11
2.2	The Worst Test Modes and Channel Details	11
3	TRANSMITTER TEST RESULTS	12
3.1	Unwanted Emissions into Restricted Frequency Bands	12
3.2	Unwanted Emissions into Non-Restricted Frequency Bands	15
3.3	Conducted Output Power	16
3.4	Number of Hopping Frequency	17
3.5	20dB and Occupied Bandwidth.....	18
3.6	Channel Separation.....	19
3.7	Number of Dwell Time.....	20
4	TEST LABORATORY INFORMATION	21

Appendix A. Unwanted Emissions into Restricted Frequency Bands

Appendix B. Unwanted Emissions into Non-Restricted Frequency Bands

Appendix C. Conducted Output Power

Appendix D. Number of Hopping Frequency

Appendix E. 20dB and Occupied Bandwidth

Appendix F. Channel Separation

Appendix G. Number of Dwell Time

Release Record

Report No.	Version	Description	Issued Date
FR7D0501-03AD	Rev. 01	Initial issue	Jul. 05, 2022

Summary of Test Results

FCC Rules	Test Items	Measured	Result
15.207	AC Power Line Conducted Emission	Note ¹	N/A
15.247(d) 15.209	Unwanted Emissions	[dBuV/m at 3m]: 287.05MHz 44.39 (Margin -1.61dB) - QP	Pass
15.247(d)	Band Edge	Meet the requirement of limit	Pass
15.247(b)(1)	Conducted Output Power	Power [dBm]: 11.04	Pass
15.247(a)(1)(iii)	Number of Hopping Channels	Meet the requirement of limit	Pass
15.247(a)(1)	Hopping Channel Separation	Meet the requirement of limit	Pass
15.247(a)(1)(iii)	Dwell Time	Meet the requirement of limit	Pass
15.203	Antenna Requirement	Meet the requirement of limit	Pass

N/A means Not Applicable.
Note¹: The EUT consumes DC power, so the test is not required.

Declaration of Conformity:

The test results with all measurement uncertainty excluded are presented in accordance with the regulation limits or requirements declared by manufacturers.

Comments and Explanations:

The declared of product specification for EUT presented in the report are provided by the manufacturer, and the manufacturer takes all the responsibilities for the accuracy of product specification.

1 General Description

1.1 Information

1.1.1 Specification of the Equipment under Test (EUT)

RF General Information				
Frequency Range (MHz)	Bluetooth Mode	Ch. Frequency (MHz)	Channel Number	Data Rate
2400-2483.5	BR	2402-2480	0-78 [79]	1 Mbps
2400-2483.5	EDR	2402-2480	0-78 [79]	2 Mbps
2400-2483.5	EDR	2402-2480	0-78 [79]	3 Mbps

Note 1: RF output power specifies that Maximum Peak Conducted Output Power.
 Note 2: Bluetooth BR uses a GFSK.
 Note 3: Bluetooth EDR uses a combination of $\pi/4$ -DQPSK and 8DPSK.

1.1.2 Antenna Details

Ant. No.	Type	Connector	Gain (dBi)
1	PIFA	N/A	2.03

1.1.3 Power Supply Type of Equipment under Test (EUT)

Power Supply Type	12Vdc
--------------------------	-------

1.1.4 Accessories

No.	Equipment	Description
1	Power with audio cable	Brand: FUSION Model: 320-01021-90 Power Line: 0.27m non-shielded without core Audio Line: 0.27m shielded without core

1.1.5 Channel List

Frequency band (MHz)				2400~2483.5			
Channel	Frequency (MHz)	Channel	Frequency (MHz)	Channel	Frequency (MHz)	Channel	Frequency (MHz)
0	2402	20	2422	40	2442	60	2462
1	2403	21	2423	41	2443	61	2463
2	2404	22	2424	42	2444	62	2464
3	2405	23	2425	43	2445	63	2465
4	2406	24	2426	44	2446	64	2466
5	2407	25	2427	45	2447	65	2467
6	2408	26	2428	46	2448	66	2468
7	2409	27	2429	47	2449	67	2469
8	2410	28	2430	48	2450	68	2470
9	2411	29	2431	49	2451	69	2471
10	2412	30	2432	50	2452	70	2472
11	2413	31	2433	51	2453	71	2473
12	2414	32	2434	52	2454	72	2474
13	2415	33	2435	53	2455	73	2475
14	2416	34	2436	54	2456	74	2476
15	2417	35	2437	55	2457	75	2477
16	2418	36	2438	56	2458	76	2478
17	2419	37	2439	57	2459	77	2479
18	2420	38	2440	58	2460	78	2480
19	2421	39	2441	59	2461	---	---

1.1.6 Test Tool and Duty Cycle

Test Tool	BT Test, V5.53, Bluetooth simulator: Brand: R&S, Model: CMW270	
Modulation Mode	Duty Cycle Of Test Signal (%)	Duty Factor (dB)
DH5	78.61%	1.05
2DH5	79.46%	1.00
3DH5	79.22%	1.01

1.1.7 Power Index of Test Tool

Modulation Mode	Test Frequency (MHz)		
	2402	2441	2480
GFSK / 1Mbps	default	default	default
$\pi/4$ -DQPSK / 2Mbps	default	default	default
8DPSK / 3Mbps	default	default	default

1.2 Local Support Equipment List

Support Equipment List					
No.	Equipment	Brand	Model	FCC ID	Remarks
1	Marine stereo	FUSION	MS-RA770	---	Provided by applicant.
2	Battery	YUASA	TX-46B24R	---	---
3	Load (x3)	---	---	---	Provided by applicant.
4	Speaker load	---	---	---	Provided by applicant.
5	AM/FM ANT	Techbrands	AR-3250	---	Provided by applicant.

1.3 Test Setup Chart

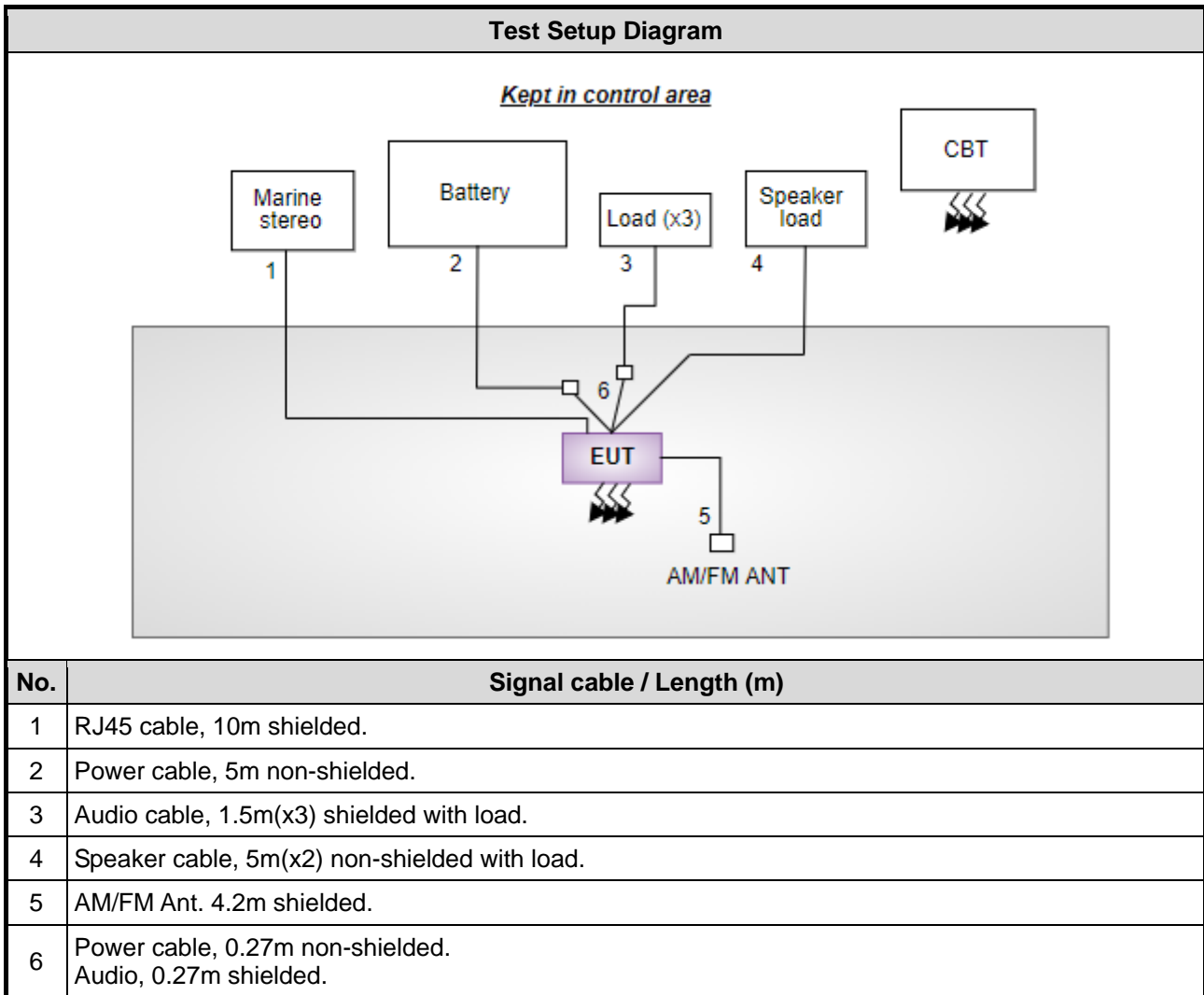

1.4 The Equipment List

Test Item	Radiated Emission				
Test Site	966 chamber1 / (03CH01-WS)				
Tested Date	May 02, 2022				
Instrument	Brand	Model No.	Serial No.	Calibration Date	Calibration Until
Receiver	R&S	ESR3	101657	Mar. 15, 2022	Mar. 14, 2023
Spectrum Analyzer	R&S	FSV40	101498	Nov. 29, 2021	Nov. 28, 2022
Loop Antenna	R&S	HFH2-Z2	100330	Nov. 08, 2021	Nov. 07, 2022
Bilog Antenna	SCHWARZBECK	VULB9168	VULB9168-522	Jun. 30, 2021	Jun. 29, 2022
Horn Antenna 1G-18G	SCHWARZBECK	BBHA 9120 D	BBHA 9120 D 1096	Dec. 03, 2021	Dec. 02, 2022
Horn Antenna 18G-40G	SCHWARZBECK	BBHA 9170	BBHA 9170508	Jan. 11, 2022	Jan. 10, 2023
Preamplifier	EMC	EMC02325	980225	Jun. 29, 2021	Jun. 28, 2022
Preamplifier	Agilent	83017A	MY39501308	Sep. 28, 2021	Sep. 27, 2022
Preamplifier	EMC	EMC184045B	980192	Jul. 14, 2021	Jul. 13, 2022
Loop Antenna Cable	KOAX KABEL	101354-BW	101354-BW	Oct. 05, 2021	Oct. 04, 2022
LF cable 3M	Woken	CFD400NL-LW	CFD400NL-001	Oct. 05, 2021	Oct. 04, 2022
LF cable 11M	EMC	EMCCFD400-NW-N W-11000	200801	Oct. 05, 2021	Oct. 04, 2022
LF cable 1M	EMC	EMCCFD400-NM-N M-1000	160502	Oct. 05, 2021	Oct. 04, 2022
RF Cable	EMC	EMC104-35M-35M- 8000	210920	Oct. 05, 2021	Oct. 04, 2022
RF Cable	HUBER+SUHNER	SUCOFLEX104	MY16019/4	Oct. 05, 2021	Oct. 04, 2022
Measurement Software	AUDIX	e3	6.120210g	NA	NA
Wireless connectivity tester	R&S	CMW270	100856	Nov. 01, 2021	Oct. 31, 2022

Note: Calibration Interval of instruments listed above is one year.

Test Item	RF Conducted				
Test Site	(TH01-WS)				
Tested Date	May 09, 2022				
Instrument	Brand	Model No.	Serial No.	Calibration Date	Calibration Until
Spectrum Analyzer	R&S	FSV40	101910	Apr. 18, 2022	Apr. 17, 2023
Power Meter	Anritsu	ML2495A	1241002	Nov. 07, 2021	Nov. 06, 2022
Power Sensor	Anritsu	MA2411B	1207366	Nov. 07, 2021	Nov. 06, 2022
Measurement Software	Sporton	SENSE-15247_FS	V5.10.7.11	NA	NA
Wireless connectivity tester	R&S	CMW270	100856	Nov. 01, 2021	Oct. 31, 2022

Note: Calibration Interval of instruments listed above is one year.

1.5 Test Standards

47 CFR FCC Part 15.247

ANSI C63.10-2013

1.6 Reference Guidance

FCC KDB 558074 D01 15.247 Meas Guidance v05r02

1.7 Deviation from Test Standard and Measurement Procedure

None

1.8 Measurement Uncertainty

The measurement uncertainties given below are based on a 95% confidence level (based on a coverage factor ($k=2$)).

Measurement Uncertainty	
Parameters	Uncertainty
Bandwidth	± 34.130 Hz
Conducted power	± 0.808 dB
Power density	± 0.583 dB
Conducted emission	± 2.715 dB
Unwanted Emission ≤ 1 GHz	± 3.41 dB
Unwanted Emission > 1 GHz	± 4.90 dB
Time	$\pm 0.1\%$

2 Test Configuration

2.1 Testing Facility

Test Laboratory	International Certification Corporation
Test Site	03CH01-WS, TH01-WS
Address of Test Site	No.3-1, Lane 6, Wen San 3rd St., Kwei Shan Dist., Tao Yuan City 33381, Taiwan (R.O.C.)

- FCC Designation No.: TW2732
- FCC site registration No.: 181692
- ISED#: 10807A
- CAB identifier: TW2732

2.2 The Worst Test Modes and Channel Details

Test item	Mode	Test Frequency (MHz)	Data Rate (Mbps)	Test Configuration
Unwanted Emissions ≤ 1GHz	GFSK	2480	1Mbps	---
Unwanted Emissions > 1GHz	GFSK 8DPSK	2402, 2441, 2480 2402, 2441, 2480	1Mbps 3Mbps	---
Conducted Output Power	GFSK π/4 DQPSK 8DPSK	2402, 2441, 2480 2402, 2441, 2480 2402, 2441, 2480	1Mbps 2Mbps 3Mbps	---
Number of Hopping Channels	GFSK π/4 DQPSK 8DPSK	2402~2480 2402~2480 2402~2480	1Mbps 2Mbps 3Mbps	---
Hopping Channel Separation 20dB and Occupied bandwidth	GFSK π/4 DQPSK 8DPSK	2402, 2441, 2480 2402, 2441, 2480 2402, 2441, 2480	1Mbps 2Mbps 3Mbps	---
Dwell Time	GFSK π/4 DQPSK 8DPSK	2402 2402 2402	1Mbps 2Mbps 3Mbps	---

3 Transmitter Test Results

3.1 Unwanted Emissions into Restricted Frequency Bands

3.1.1 Limit of Unwanted Emissions into Restricted Frequency Bands

Restricted Band Emissions Limit			
Frequency Range (MHz)	Field Strength (uV/m)	Field Strength (dBuV/m)	Measure Distance (m)
0.009~0.490	2400/F(kHz)	48.5 - 13.8	300
0.490~1.705	24000/F(kHz)	33.8 - 23	30
1.705~30.0	30	29	30
30~88	100	40	3
88~216	150	43.5	3
216~960	200	46	3
Above 960	500	54	3

Note 1:
Qusai-Peak value is measured for frequency below 1GHz except for 9–90 kHz, 110–490 kHz frequency band. Peak and average value are measured for frequency above 1GHz. The limit on average radio frequency emission is as above table. The limit on peak radio frequency emissions is 20 dB above the maximum permitted average emission limit

Note 2:
Measurements may be performed at a distance other than what is specified provided. When performing measurements at a distance other than that specified, the results shall be extrapolated to the specified distance using an extrapolation factor as below, Frequency at or above 30 MHz: 20 dB/decade Frequency below 30 MHz: 40 dB/decade.

3.1.2 Test Procedures

1. Measurement is made at a semi-anechoic chamber that incorporates a turntable allowing a EUT rotation of 360°. A continuously-rotating, remotely-controlled turntable is installed at the test site to support the EUT and facilitate determination of the direction of maximum radiation for each EUT emission frequency. The EUT is placed at test table. For emissions testing at or below 1 GHz, the table height is 80 cm above the reference ground plane. For emission measurements above 1 GHz, the table height is 1.5 m
2. Measurement is made with the antenna positioned in both the horizontal and vertical planes of polarization. The measurement antenna is varied in height (1m ~ 4m) above the reference ground plane to obtain the maximum signal strength. Distance between EUT and antenna is 3 m.
3. This investigation is performed with the EUT rotated 360°, the antenna height scanned between 1 m and 4 m, and the antenna rotated to repeat the measurements for both the horizontal and vertical antenna polarizations.

Note:

1. 120kHz measurement bandwidth of test receiver and Quasi-peak detector is for radiated emission below 1GHz.
2. Radiated emission above 1GHz / Peak value
RBW=1MHz, VBW=3MHz and Peak detector
Radiated emission above 1GHz / Average value for harmonics
The average value is: Average = Peak value + 20log(Duty cycle) Where the duty factor is calculated from following formula for DH5 packet type which has worst duty factor:
3.
$$20\log(\text{Duty cycle}) = 20\log \frac{1\text{s} / 1600 * 5}{100\text{ ms}} = -30.1\text{dB}$$
4. Radiated emission above 1GHz / Average value for other emissions
RBW=1MHz, VBW=1/T and Peak detector

3.1.3 Test Setup

Radiated Emissions below 1 GHz

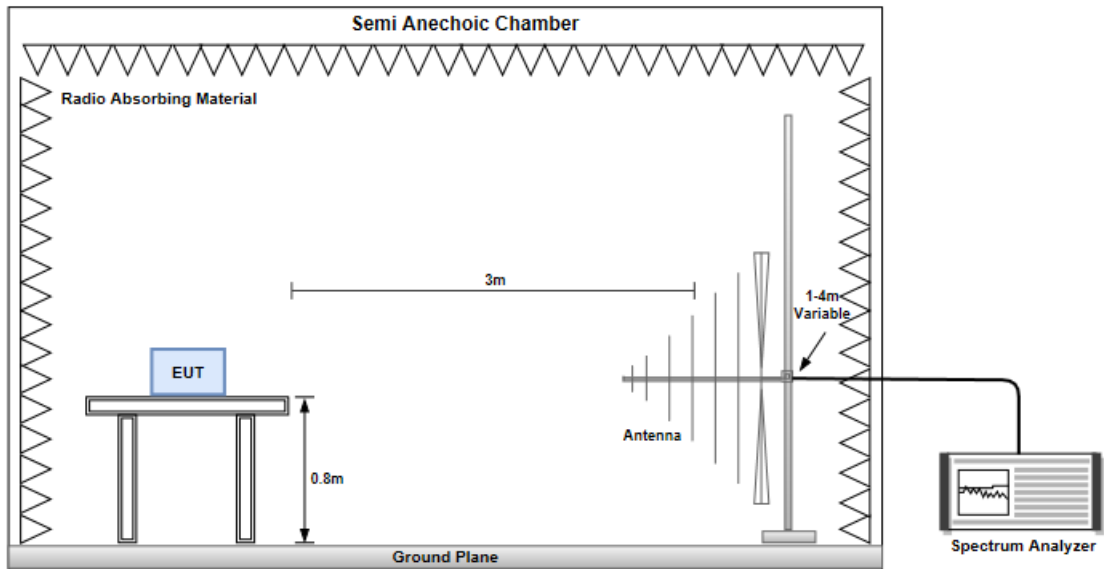

Radiated Emissions above 1 GHz

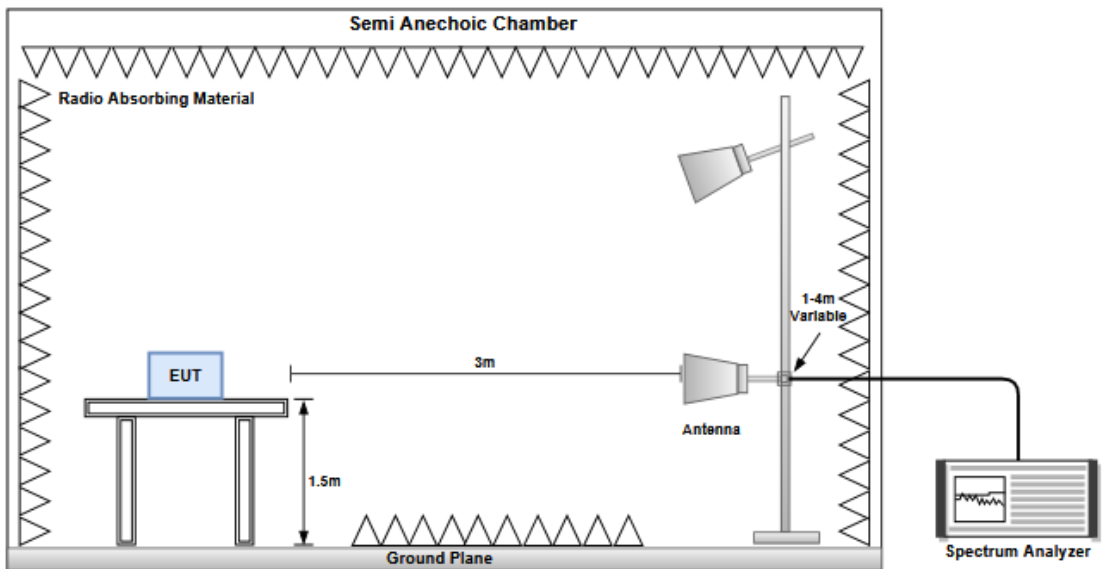

3.1.4 Test Results

Refer to Appendix A.

3.2 Unwanted Emissions into Non-Restricted Frequency Bands

3.2.1 Limit of Unwanted Emissions into Non-Restricted Frequency Bands

Peak power in any 100 kHz bandwidth outside of the authorized frequency band shall be attenuated by at least 20 dB relative to the maximum in-band peak PSD level in 100 kHz.

3.2.2 Test Procedures

Reference level measurement

1. Set RBW=100kHz, VBW = 300kHz , Detector = Peak, Sweep time = Auto
2. Trace = max hold , Allow Trace to fully stabilize
3. Use the peak marker function to determine the maximum PSD level

Emission level measurement

1. Set RBW=100kHz, VBW = 300kHz , Detector = Peak, Sweep time = Auto
2. Trace = max hold , Allow Trace to fully stabilize
3. Scan Frequency range is up to 25GHz
4. Use the peak marker function to determine the maximum amplitude level

3.2.3 Test Setup

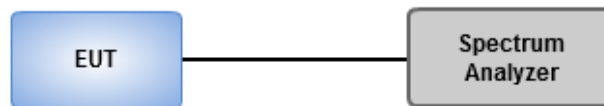

3.2.4 Test Results

Ambient Condition	24°C / 66%	Tested By	Aska Huang
--------------------------	------------	------------------	------------

Refer to Appendix B.

3.3 Conducted Output Power

3.3.1 Limit of Conducted Output Power

- 1 Watt
For frequency hopping systems operating in the 2400–2483.5 MHz band employing at least 75 non overlapping hopping channels, and all frequency hopping systems in the 5725–5850 MHz band.
- 0.125 Watt
For all other frequency hopping systems in the 2400–2483.5 MHz band.
- 0.125 Watt
For Frequency hopping systems operating in the 2400–2483.5 MHz band have hopping channel carrier frequencies that are separated by two-thirds of the 20 dB bandwidth of the hopping channel.

3.3.2 Test Procedures

1. A wideband power meter is used for power measurement. Bandwidth of power sensor and meter is 50MHz
2. If duty cycle of test signal is not 100 %, trigger and gating function of power meter will be enabled to capture transmission burst for measuring output power

3.3.3 Test Setup

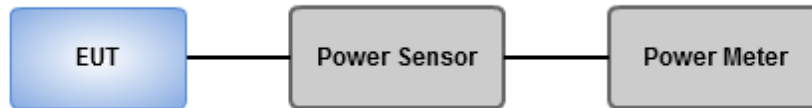

3.3.4 Test Results

Ambient Condition	24°C / 66%	Tested By	Aska Huang
--------------------------	------------	------------------	------------

Refer to Appendix C.

3.4 Number of Hopping Frequency

3.4.1 Limit of Number of Hopping Frequency

Frequency hopping systems in the 2400–2483.5 MHz band shall use at least 15 channels.

3.4.2 Test Procedures

1. Set RBW = 100kHz, VBW = 300kHz, Sweep time = Auto, Detector = Peak Trace max hold.
2. Allow trace to stabilize.

3.4.3 Test Setup

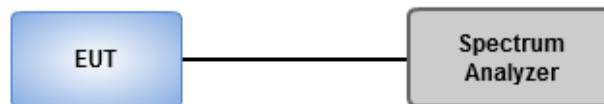

3.4.4 Test Results

Ambient Condition	24°C / 66%	Tested By	Aska Huang
-------------------	------------	-----------	------------

Refer to Appendix D.

3.5 20dB and Occupied Bandwidth

3.5.1 Test Procedures

20dB Bandwidth

1. Set RBW=20kHz, VBW=100kHz, Sweep time = Auto, Detector=Peak , Trace max hold
2. Allow trace to stabilize
3. Measure the maximum width of the emission that is constrained by the frequencies associated with the two outermost amplitude points (upper and lower) that are attenuated by 20 dB relative to the maximum level measured in the fundamental emission.

Occupied Bandwidth

1. Set RBW=20kHz, VBW=100kHz, Sweep time = Auto, Detector=Sample , Trace max hold
2. Allow trace to stabilize
3. Use Occupied bandwidth function of spectrum analyzer to measuring 99% occupied bandwidth

3.5.2 Test Setup

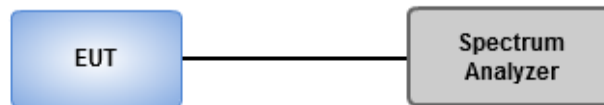

3.5.3 Test Results

Ambient Condition	24°C / 66%	Tested By	Aska Huang
--------------------------	------------	------------------	------------

Refer to Appendix E.

3.6 Channel Separation

3.6.1 Limit of Channel Separation

- Frequency hopping systems shall have hopping channel carrier frequencies separated by a minimum of 25 kHz or the 20 dB bandwidth of the hopping channel, whichever is greater.
- Frequency hopping systems operating in the 2400–2483.5 MHz band may have hopping channel carrier frequencies that are separated by 25 kHz or two-thirds of the 20 dB bandwidth of the hopping channel, whichever is greater.

3.6.2 Test Procedures

1. Set RBW=30kHz, VBW=100kHz, Sweep time = Auto, Detector=Peak Trace max hold
2. Allow trace to stabilize
3. Use the marker-delta function to determine the separation between the peaks of the adjacent channels. The EUT shall show compliance with the appropriate regulatory limit

3.6.3 Test Setup

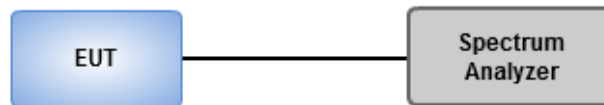

3.6.4 Test Results

Ambient Condition	24°C / 66%	Tested By	Aska Huang
--------------------------	------------	------------------	------------

Refer to Appendix F.

3.7 Number of Dwell Time

3.7.1 Limit of Dwell time

The average time of occupancy on any channel shall not be greater than 0.4 seconds within a period of 0.4 seconds multiplied by the number of hopping channels employed.

3.7.2 Test Procedures

1. Set RBW=300 kHz, VBW=1 MHz, Sweep time=8 ms, Detector=Peak, Span=0 Hz, Trace max hold.
2. Enable gating and trigger function of spectrum analyzer to measure burst on time.
3. Set RBW=300 kHz, VBW=1 MHz, Sweep time=5 s / 2 s, Detector=Peak, Span=0 Hz, Trace max hold.
4. Enable gating and trigger function of spectrum analyzer to measure burst on number of transmission.
5. Set RBW=300 kHz, VBW=1 MHz, Sweep time=31.6 s / 8 s, Detector=Peak, Span=0 Hz, Trace max hold.
6. Enable gating and trigger function of spectrum analyzer to measure burst on number of transmission of entire time cycle.

3.7.3 Test Setup

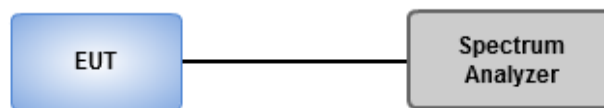

3.7.4 Test Results

Ambient Condition	24°C / 66%	Tested By	Aska Huang
--------------------------	------------	------------------	------------

Refer to Appendix G.

4 Test laboratory information

Established in 2012, ICC provides foremost EMC & RF Testing and advisory consultation services by our skilled engineers and technicians. Our services employ a wide variety of advanced edge test equipment and one of the widest certification extents in the business.

International Certification Corporation (EMC and Wireless Communication Laboratory), it is our definitive objective is to institute long term, trust-based associations with our clients. The expectation we set up with our clients is based on outstanding service, practical expertise and devotion to a certified value structure. Our passion is to grant our clients with best EMC / RF services by oriented knowledgeable and accommodating staff.

Our Test sites are located at Linkou District and Kwei Shan District. Location map can be found on our website <http://www.icertifi.com.tw>.

Linkou

Tel: 886-2-2601-1640

No.30-2, Ding Fwu Tsuen, Lin Kou
District, New Taipei City, Taiwan
(R.O.C.)

Kwei Shan

Tel: 886-3-271-8666

No.3-1, Lane 6, Wen San 3rd
St., Kwei Shan Dist., Tao Yuan
City 33381, Taiwan (R.O.C.)
No.2-1, Lane 6, Wen San 3rd
St., Kwei Shan Dist., Tao Yuan
City 33381, Taiwan (R.O.C.)

Kwei Shan Site II

Tel: 886-3-271-8640

No.14-1, Lane 19, Wen San 3rd
St., Kwei Shan Dist., Tao Yuan
City 333, Taiwan (R.O.C.)

If you have any suggestion, please feel free to contact us as below information.

Tel: 886-3-271-8666

Fax: 886-3-318-0345

Email: ICC_Service@icertifi.com.tw

==END==



Unwanted Emissions (Below 1GHz)

Modulation	GFSK	Test Freq. (MHz)	2480
Polarization	Horizontal		

Test By :Brad Wu Temperature(°C):23 Humidity(%):66

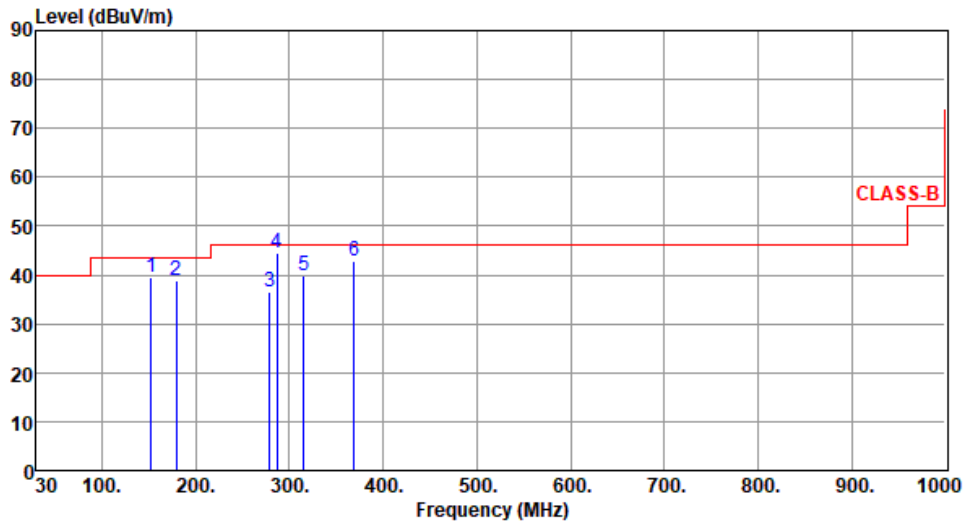

	Freq. MHz	Emission level dBUV/m	Limit dBUV/m	Margin dB	SA reading dBUV	Factor dB/m	Remark	ANT High cm	Turn Table deg
1	152.22	39.48	43.50	-4.02	48.29	-8.81	Peak	---	---
2	179.38	38.85	43.50	-4.65	49.01	-10.16	QP	148	119
3	279.29	36.64	46.00	-9.36	45.35	-8.71	QP	110	129
4	287.05	44.39	46.00	-1.61	52.87	-8.48	QP	100	149
5	315.18	39.93	46.00	-6.07	47.60	-7.67	QP	100	154
6	368.90	42.73	46.00	-3.27	49.20	-6.47	QP	100	156

Note 1: Emission Level (dBUV/m) = SA Reading (dBUV) + Factor* (dB/m)

*Factor includes antenna factor , cable loss and amplifier gain

Note 2: Margin (dB) = Emission level (dBUV/m) – Limit (dBUV/m).

Note 3: All spurious emissions below 30MHz are more than 20 dB below the limit.



Modulation	GFSK	Test Freq. (MHz)	2480
Polarization	Vertical		

Test By :Brad Wu Temperature(°C):23 Humidity(%):66

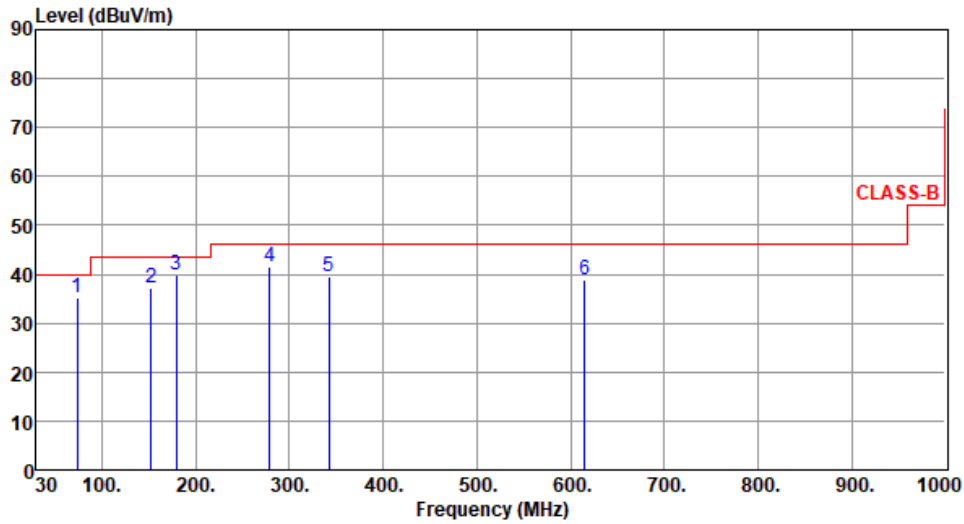

	Freq. MHz	Emission level dBuV/m	Limit dBuV/m	Margin dB	SA reading dBuV	Factor dB/m	Remark	ANT High cm	Turn Table deg
1	73.65	35.29	40.00	-4.71	47.15	-11.86	Peak	---	---
2	152.22	37.24	43.50	-6.26	46.05	-8.81	Peak	---	---
3	179.38	39.75	43.50	-3.75	49.91	-10.16	Peak	---	---
4	279.29	41.57	46.00	-4.43	50.28	-8.71	Peak	---	---
5	342.34	39.37	46.00	-6.63	46.63	-7.26	Peak	---	---
6	614.91	38.89	46.00	-7.11	39.57	-0.68	Peak	---	---

Note 1: Emission Level (dBuV/m) = SA Reading (dBuV) + Factor* (dB/m)

*Factor includes antenna factor , cable loss and amplifier gain

Note 2: Margin (dB) = Emission level (dBuV/m) – Limit (dBuV/m).

Note 3: All spurious emissions below 30MHz are more than 20 dB below the limit.



Unwanted Emissions (Above 1GHz) for GFSK

Modulation	GFSK	Test Freq. (MHz)	2402
Polarization	Horizontal		

Test By :Brad Wu Temperature(°C):23 Humidity(%):66

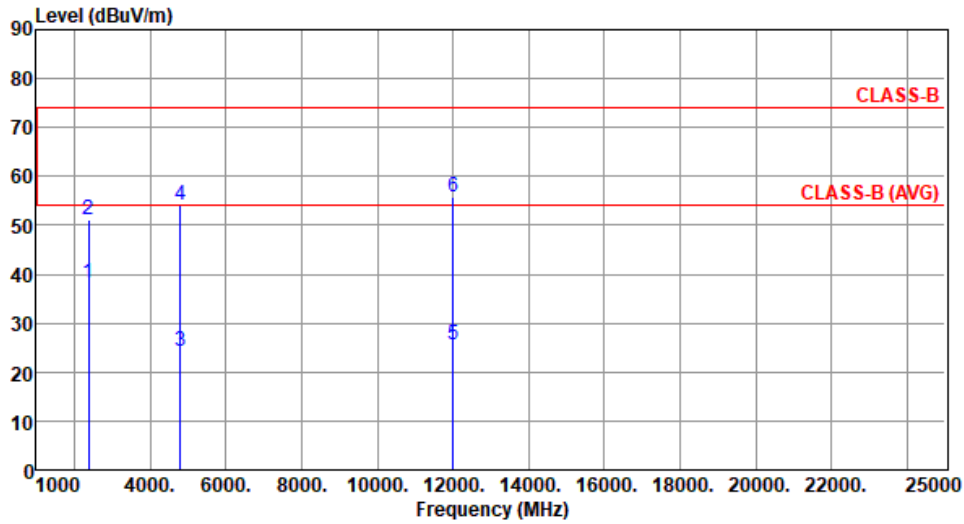

	Freq. MHz	Emission level dBuV/m	Limit dBuV/m	Margin dB	SA reading dBuV	Factor dB/m	Remark	ANT High cm	Turn Table deg
1	2390.00	38.20	54.00	-15.80	40.95	-2.75	Average	100	211
2	2390.00	51.11	74.00	-22.89	53.86	-2.75	Peak	100	211
3	4804.00	24.15	54.00	-29.85			Average	100	358
4	4804.00	54.25	74.00	-19.75	50.12	4.13	Peak	100	358
5	12010.00	25.63	54.00	-28.37			Average	100	14
6	12010.00	55.73	74.00	-18.27	42.11	13.62	Peak	100	14

Note 1: Emission Level (dBuV/m) = SA Reading (dBuV) + Factor* (dB/m)

*Factor includes antenna factor , cable loss and amplifier gain

Note 2: Margin (dB) = Emission level (dBuV/m) – Limit (dBuV/m).

Note 3: When average value is calculated not measured, no SA reading and factor value are listed.



Modulation	GFSK	Test Freq. (MHz)	2402
Polarization	Vertical		

Test By :Brad Wu Temperature(°C):23 Humidity(%):66

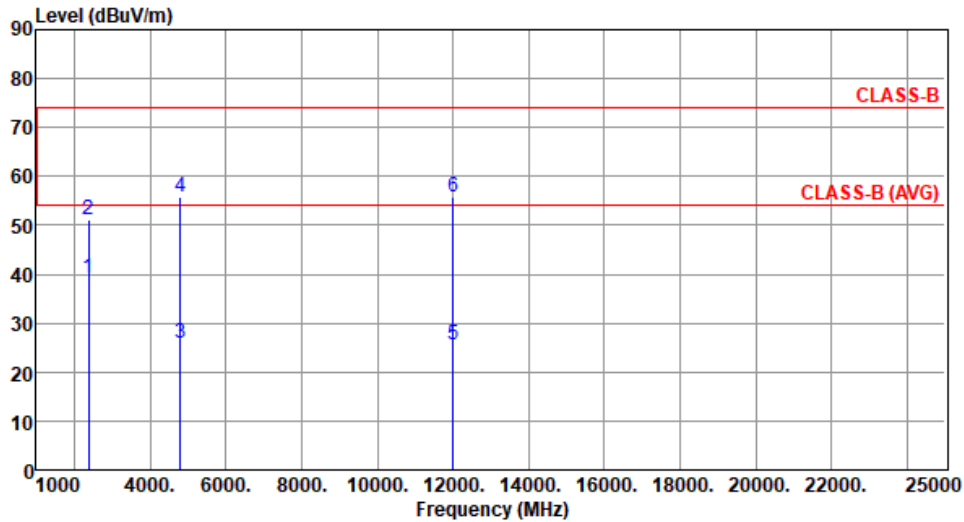

	Freq. MHz	Emission level dBuV/m	Limit dBuV/m	Margin dB	SA reading dBuV	Factor dB/m	Remark	ANT High cm	Turn Table deg
1	2390.00	39.03	54.00	-14.97	41.78	-2.75	Average	100	301
2	2390.00	51.21	74.00	-22.79	53.96	-2.75	Peak	100	301
3	4804.00	25.78	54.00	-28.22			Average	100	318
4	4804.00	55.88	74.00	-18.12	51.75	4.13	Peak	100	318
5	12010.00	25.73	54.00	-28.27			Average	100	35
6	12010.00	55.83	74.00	-18.17	42.21	13.62	Peak	100	35

Note 1: Emission Level (dBuV/m) = SA Reading (dBuV) + Factor* (dB/m)

*Factor includes antenna factor , cable loss and amplifier gain

Note 2: Margin (dB) = Emission level (dBuV/m) – Limit (dBuV/m).

Note 3: When average value is calculated not measured, no SA reading and factor value are listed.



Modulation	GFSK	Test Freq. (MHz)	2441
Polarization	Horizontal		

Test By :Brad Wu Temperature(°C):23 Humidity(%):66

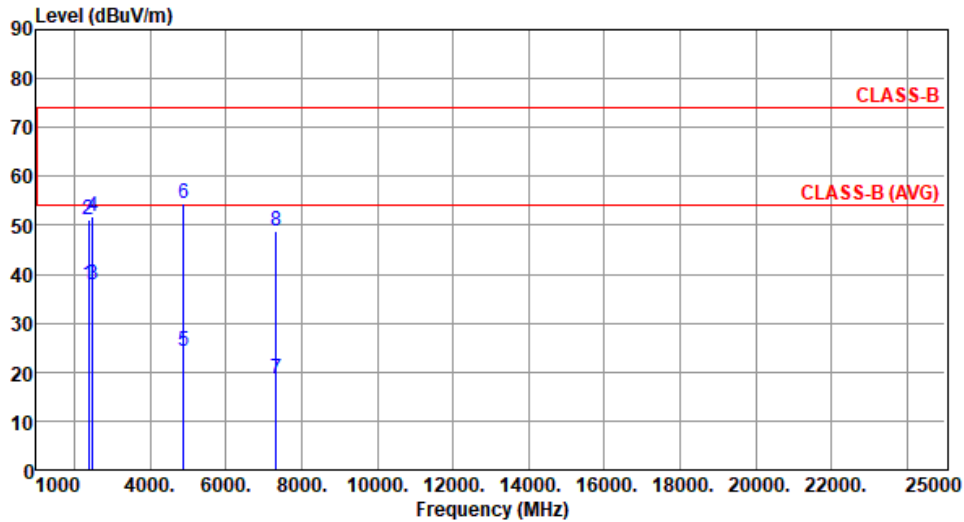

	Freq. MHz	Emission level dBuV/m	Limit dBuV/m	Margin dB	SA reading dBuV	Factor dB/m	Remark	ANT High cm	Turn Table deg
1	2390.00	37.82	54.00	-16.18	40.57	-2.75	Average	100	208
2	2390.00	51.15	74.00	-22.85	53.90	-2.75	Peak	100	208
3	2483.50	37.82	54.00	-16.18	40.52	-2.70	Average	100	208
4	2483.50	51.91	74.00	-22.09	54.61	-2.70	Peak	100	208
5	4882.00	24.26	54.00	-29.74			Average	100	353
6	4882.00	54.36	74.00	-19.64	50.24	4.12	Peak	100	353
7	7323.00	18.74	54.00	-35.26			Average	100	11
8	7323.00	48.84	74.00	-25.16	39.57	9.27	Peak	100	11

Note 1: Emission Level (dBuV/m) = SA Reading (dBuV) + Factor* (dB/m)

*Factor includes antenna factor , cable loss and amplifier gain

Note 2: Margin (dB) = Emission level (dBuV/m) – Limit (dBuV/m).

Note 3: When average value is calculated not measured, no SA reading and factor value are listed.



Modulation	GFSK	Test Freq. (MHz)	2441
Polarization	Vertical		

Test By :Brad Wu Temperature(°C):23 Humidity(%):66

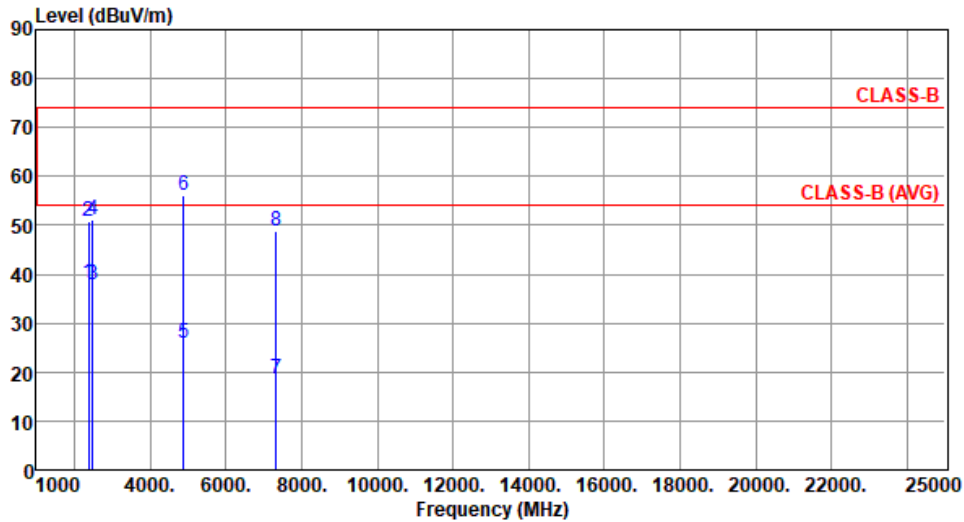

	Freq. MHz	Emission level dBuV/m	Limit dBuV/m	Margin dB	SA reading dBuV	Factor dB/m	Remark	ANT High cm	Turn Table deg
1	2390.00	38.03	54.00	-15.97	40.78	-2.75	Average	100	306
2	2390.00	50.90	74.00	-23.10	53.65	-2.75	Peak	100	306
3	2483.50	37.85	54.00	-16.15	40.55	-2.70	Average	100	306
4	2483.50	51.11	74.00	-22.89	53.81	-2.70	Peak	100	306
5	4882.00	25.91	54.00	-28.09			Average	100	313
6	4882.00	56.01	74.00	-17.99	51.89	4.12	Peak	100	313
7	7323.00	18.65	54.00	-35.35			Average	100	26
8	7323.00	48.75	74.00	-25.25	39.48	9.27	Peak	100	26

Note 1: Emission Level (dBuV/m) = SA Reading (dBuV) + Factor* (dB/m)

*Factor includes antenna factor , cable loss and amplifier gain

Note 2: Margin (dB) = Emission level (dBuV/m) – Limit (dBuV/m).

Note 3: When average value is calculated not measured, no SA reading and factor value are listed.



Modulation	GFSK	Test Freq. (MHz)	2480
Polarization	Horizontal		

Test By :Brad Wu Temperature(°C):23 Humidity(%):66

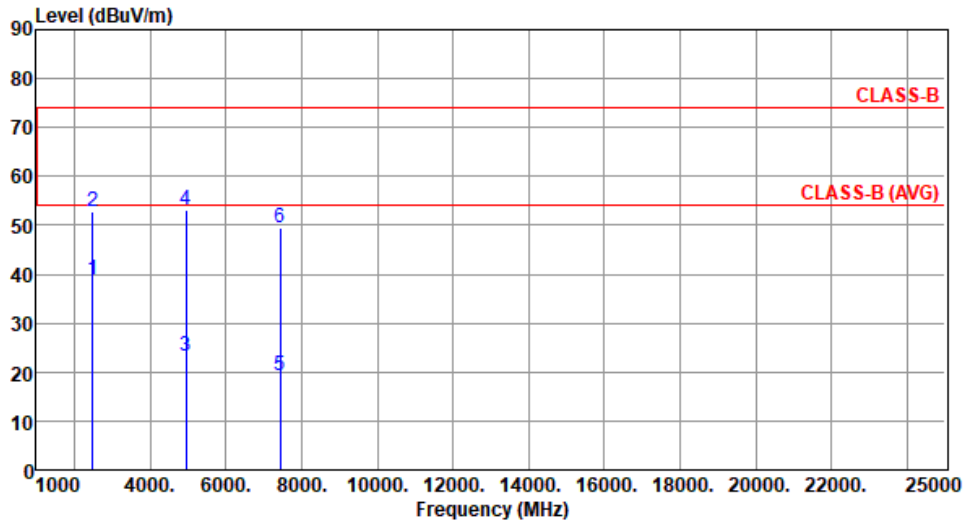

	Freq. MHz	Emission level dBuV/m	Limit dBuV/m	Margin dB	SA reading dBuV	Factor dB/m	Remark	ANT High cm	Turn Table deg
1	2483.50	39.01	54.00	-14.99	41.71	-2.70	Average	100	351
2	2483.50	52.85	74.00	-21.15	55.55	-2.70	Peak	100	351
3	4960.00	23.20	54.00	-30.80			Average	100	351
4	4960.00	53.30	74.00	-20.70	49.27	4.03	Peak	100	351
5	7440.00	19.22	54.00	-34.78			Average	100	13
6	7440.00	49.32	74.00	-24.68	39.95	9.37	Peak	100	13

Note 1: Emission Level (dBuV/m) = SA Reading (dBuV) + Factor* (dB/m)

*Factor includes antenna factor , cable loss and amplifier gain

Note 2: Margin (dB) = Emission level (dBuV/m) – Limit (dBuV/m).

Note 3: When average value is calculated not measured, no SA reading and factor value are listed.



Modulation	GFSK	Test Freq. (MHz)	2480
Polarization	Vertical		

Test By :Brad Wu Temperature(°C):23 Humidity(%):66

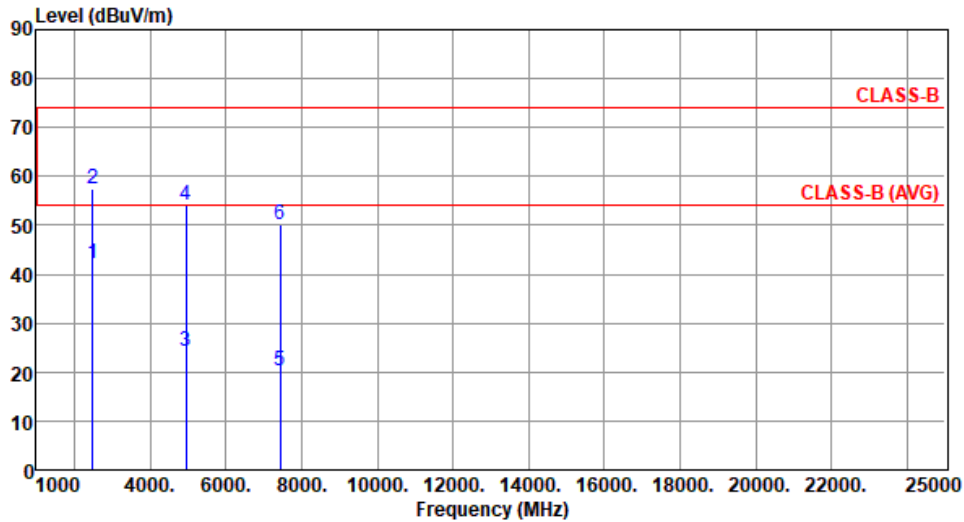

	Freq. MHz	Emission level dBuV/m	Limit dBuV/m	Margin dB	SA reading dBuV	Factor dB/m	Remark	ANT High cm	Turn Table deg
1	2483.50	42.26	54.00	-11.74	44.96	-2.70	Average	100	305
2	2483.50	57.48	74.00	-16.52	60.18	-2.70	Peak	100	305
3	4960.00	24.14	54.00	-29.86			Average	100	319
4	4960.00	54.24	74.00	-19.76	50.21	4.03	Peak	100	319
5	7440.00	20.17	54.00	-33.83			Average	100	35
6	7440.00	50.27	74.00	-23.73	40.90	9.37	Peak	100	35

Note 1: Emission Level (dBuV/m) = SA Reading (dBuV) + Factor* (dB/m)

*Factor includes antenna factor , cable loss and amplifier gain

Note 2: Margin (dB) = Emission level (dBuV/m) – Limit (dBuV/m).

Note 3: When average value is calculated not measured, no SA reading and factor value are listed.



Unwanted Emissions (Above 1GHz) for 8DPSK

Modulation	8DPSK	Test Freq. (MHz)	2402
Polarization	Horizontal		

Test By :Brad Wu Temperature(°C):23 Humidity(%):66

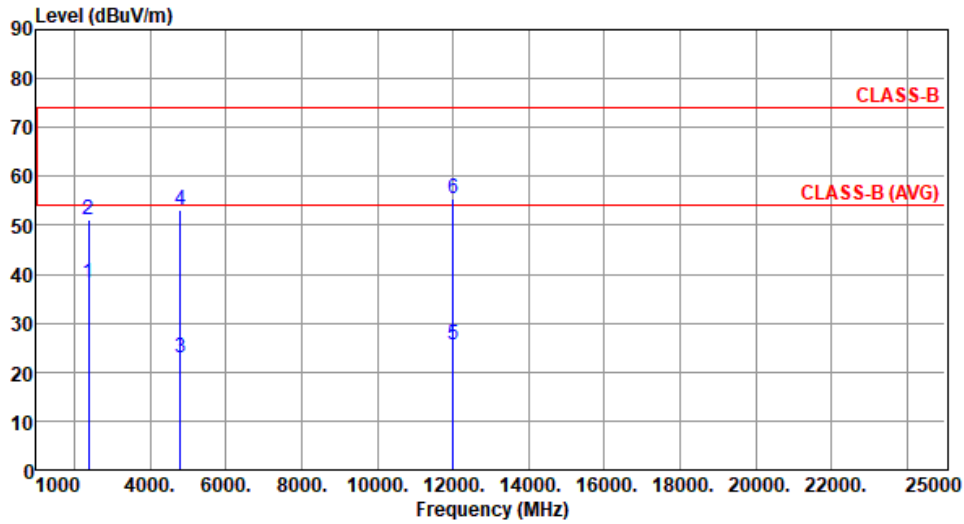

	Freq. MHz	Emission level dBuV/m	Limit dBuV/m	Margin dB	SA reading dBuV	Factor dB/m	Remark	ANT High cm	Turn Table deg
1	2390.00	38.03	54.00	-15.97	40.78	-2.75	Average	100	218
2	2390.00	51.16	74.00	-22.84	53.91	-2.75	Peak	100	218
3	4804.00	22.94	54.00	-31.06			Average	100	355
4	4804.00	53.04	74.00	-20.96	48.91	4.13	Peak	100	355
5	12010.00	25.44	54.00	-28.56			Average	100	28
6	12010.00	55.54	74.00	-18.46	41.92	13.62	Peak	100	28

Note 1: Emission Level (dBuV/m) = SA Reading (dBuV) + Factor* (dB/m)

*Factor includes antenna factor , cable loss and amplifier gain

Note 2: Margin (dB) = Emission level (dBuV/m) – Limit (dBuV/m).

Note 3: When average value is calculated not measured, no SA reading and factor value are listed.



Modulation	8DPSK	Test Freq. (MHz)	2402
Polarization	Vertical		

Test By :Brad Wu Temperature(°C):23 Humidity(%):66

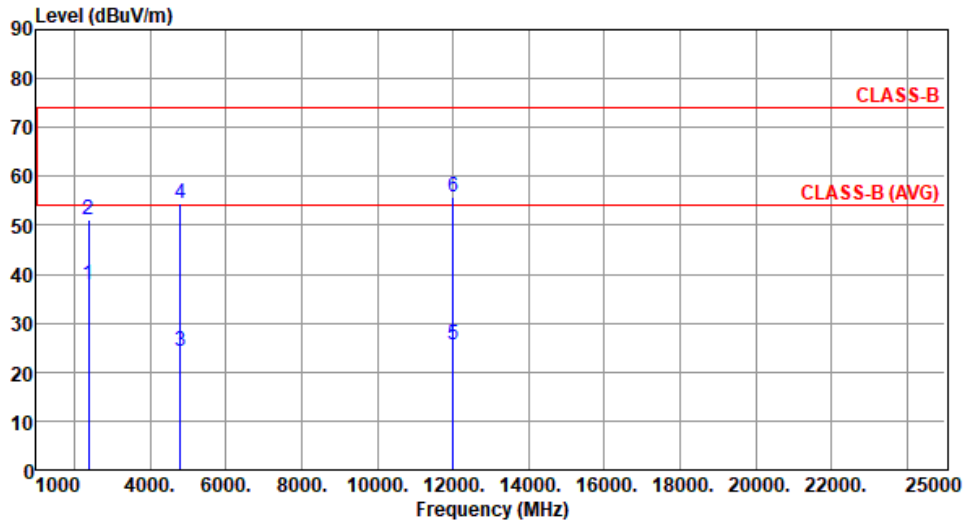

	Freq. MHz	Emission level dBuV/m	Limit dBuV/m	Margin dB	SA reading dBuV	Factor dB/m	Remark	ANT High cm	Turn Table deg
1	2390.00	37.90	54.00	-16.10	40.65	-2.75	Average	100	302
2	2390.00	51.13	74.00	-22.87	53.88	-2.75	Peak	100	302
3	4804.00	24.24	54.00	-29.76			Average	100	321
4	4804.00	54.34	74.00	-19.66	50.21	4.13	Peak	100	321
5	12010.00	25.62	54.00	-28.38			Average	100	41
6	12010.00	55.72	74.00	-18.28	42.10	13.62	Peak	100	41

Note 1: Emission Level (dBuV/m) = SA Reading (dBuV) + Factor* (dB/m)

*Factor includes antenna factor , cable loss and amplifier gain

Note 2: Margin (dB) = Emission level (dBuV/m) – Limit (dBuV/m).

Note 3: When average value is calculated not measured, no SA reading and factor value are listed.



Modulation	8DPSK	Test Freq. (MHz)	2441
Polarization	Horizontal		

Test By :Brad Wu Temperature(°C):23 Humidity(%):66

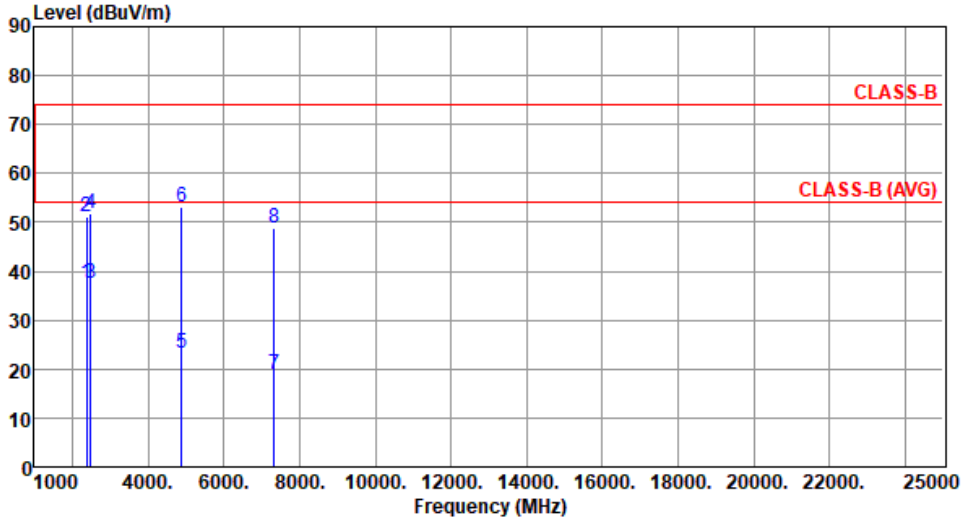

	Freq. MHz	Emission level dBuV/m	Limit dBuV/m	Margin dB	SA reading dBuV	Factor dB/m	Remark	ANT High cm	Turn Table deg
1	2390.00	37.60	54.00	-16.40	40.35	-2.75	Average	100	204
2	2390.00	51.04	74.00	-22.96	53.79	-2.75	Peak	100	204
3	2483.50	37.64	54.00	-16.36	40.34	-2.70	Average	100	204
4	2483.50	51.83	74.00	-22.17	54.53	-2.70	Peak	100	204
5	4882.00	23.09	54.00	-30.91			Average	100	349
6	4882.00	53.19	74.00	-20.81	49.07	4.12	Peak	100	349
7	7323.00	18.85	54.00	-35.15			Average	100	8
8	7323.00	48.95	74.00	-25.05	39.68	9.27	Peak	100	8

Note 1: Emission Level (dBuV/m) = SA Reading (dBuV) + Factor* (dB/m)

*Factor includes antenna factor , cable loss and amplifier gain

Note 2: Margin (dB) = Emission level (dBuV/m) – Limit (dBuV/m).

Note 3: When average value is calculated not measured, no SA reading and factor value are listed.



Modulation	8DPSK	Test Freq. (MHz)	2441
Polarization	Vertical		

Test By :Brad Wu Temperature(°C):23 Humidity(%):66

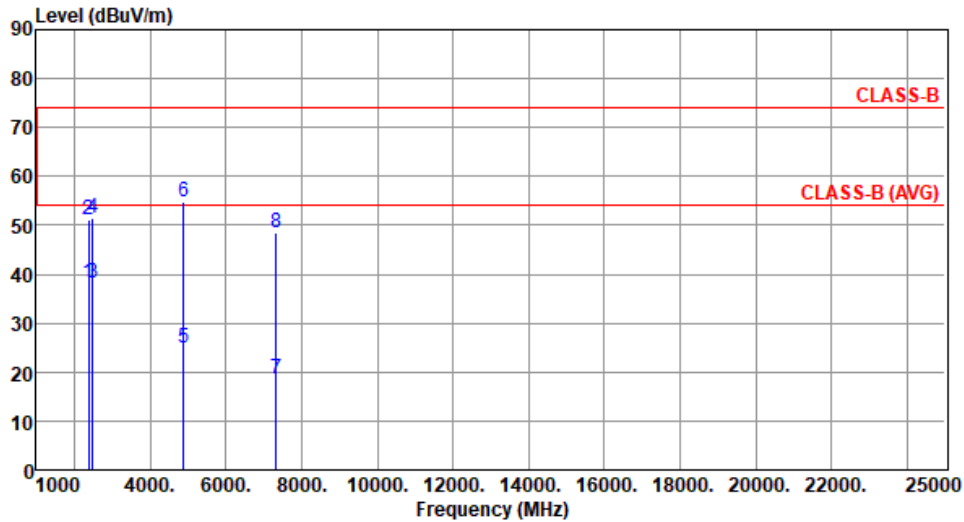

	Freq. MHz	Emission level dBuV/m	Limit dBuV/m	Margin dB	SA reading dBuV	Factor dB/m	Remark	ANT High cm	Turn Table deg
1	2390.00	38.10	54.00	-15.90	40.85	-2.75	Average	100	309
2	2390.00	51.11	74.00	-22.89	53.86	-2.75	Peak	100	309
3	2483.50	38.07	54.00	-15.93	40.77	-2.70	Average	100	309
4	2483.50	51.33	74.00	-22.67	54.03	-2.70	Peak	100	309
5	4882.00	24.85	54.00	-29.15			Average	100	316
6	4882.00	54.95	74.00	-19.05	50.83	4.12	Peak	100	316
7	7323.00	18.48	54.00	-35.52			Average	100	12
8	7323.00	48.58	74.00	-25.42	39.31	9.27	Peak	100	12

Note 1: Emission Level (dBuV/m) = SA Reading (dBuV) + Factor* (dB/m)

*Factor includes antenna factor , cable loss and amplifier gain

Note 2: Margin (dB) = Emission level (dBuV/m) – Limit (dBuV/m).

Note 3: When average value is calculated not measured, no SA reading and factor value are listed.



Modulation	8DPSK	Test Freq. (MHz)	2480
Polarization	Horizontal		

Test By :Brad Wu Temperature(°C):23 Humidity(%):66

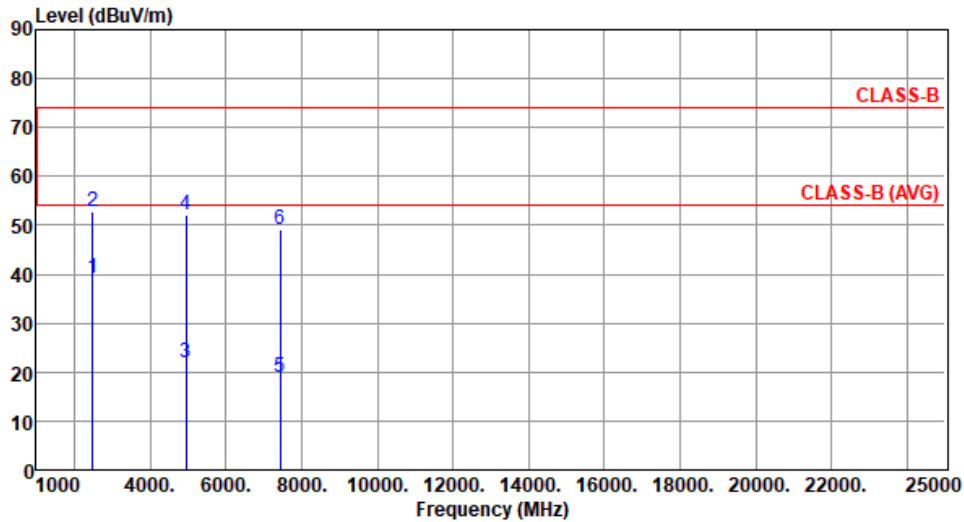

	Freq. MHz	Emission level dBuV/m	Limit dBuV/m	Margin dB	SA reading dBuV	Factor dB/m	Remark	ANT High cm	Turn Table deg
1	2483.50	39.14	54.00	-14.86	41.84	-2.70	Average	100	355
2	2483.50	52.77	74.00	-21.23	55.47	-2.70	Peak	100	355
3	4960.00	22.03	54.00	-31.97			Average	100	352
4	4960.00	52.13	74.00	-21.87	48.10	4.03	Peak	100	352
5	7440.00	19.07	54.00	-34.93			Average	100	25
6	7440.00	49.17	74.00	-24.83	39.80	9.37	Peak	100	25

Note 1: Emission Level (dBuV/m) = SA Reading (dBuV) + Factor* (dB/m)

*Factor includes antenna factor , cable loss and amplifier gain

Note 2: Margin (dB) = Emission level (dBuV/m) – Limit (dBuV/m).

Note 3: When average value is calculated not measured, no SA reading and factor value are listed.



Modulation	8DPSK	Test Freq. (MHz)	2480
Polarization	Vertical		

Test By :Brad Wu Temperature(°C):23 Humidity(%):66

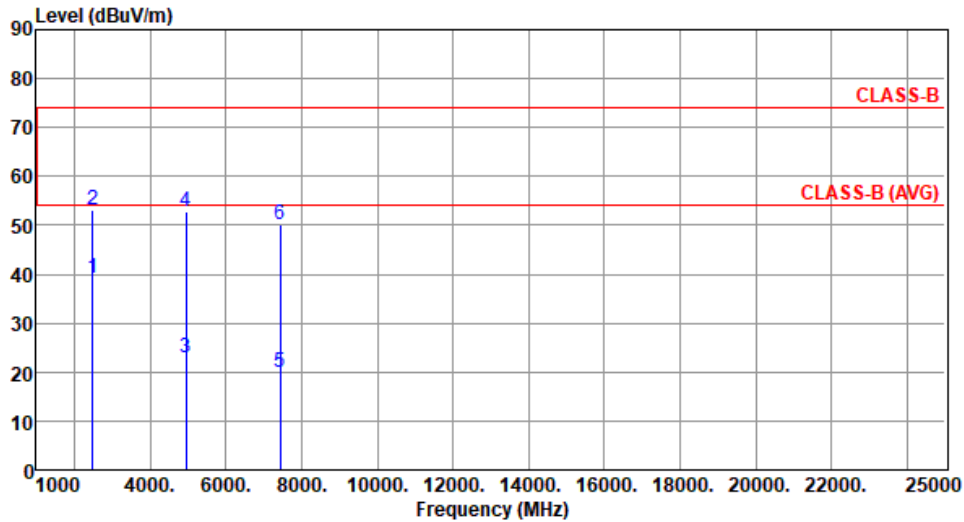

	Freq. MHz	Emission level dBuV/m	Limit dBuV/m	Margin dB	SA reading dBuV	Factor dB/m	Remark	ANT High cm	Turn Table deg
1	2483.50	39.29	54.00	-14.71	41.99	-2.70	Average	100	304
2	2483.50	52.99	74.00	-21.01	55.69	-2.70	Peak	100	304
3	4960.00	22.80	54.00	-31.20			Average	100	326
4	4960.00	52.90	74.00	-21.10	48.87	4.03	Peak	100	326
5	7440.00	20.02	54.00	-33.98	-----	-----	Average	100	42
6	7440.00	50.12	74.00	-23.88	40.75	9.37	Peak	100	42

Note 1: Emission Level (dBuV/m) = SA Reading (dBuV) + Factor* (dB/m)

*Factor includes antenna factor , cable loss and amplifier gain

Note 2: Margin (dB) = Emission level (dBuV/m) – Limit (dBuV/m).

Note 3: When average value is calculated not measured, no SA reading and factor value are listed.

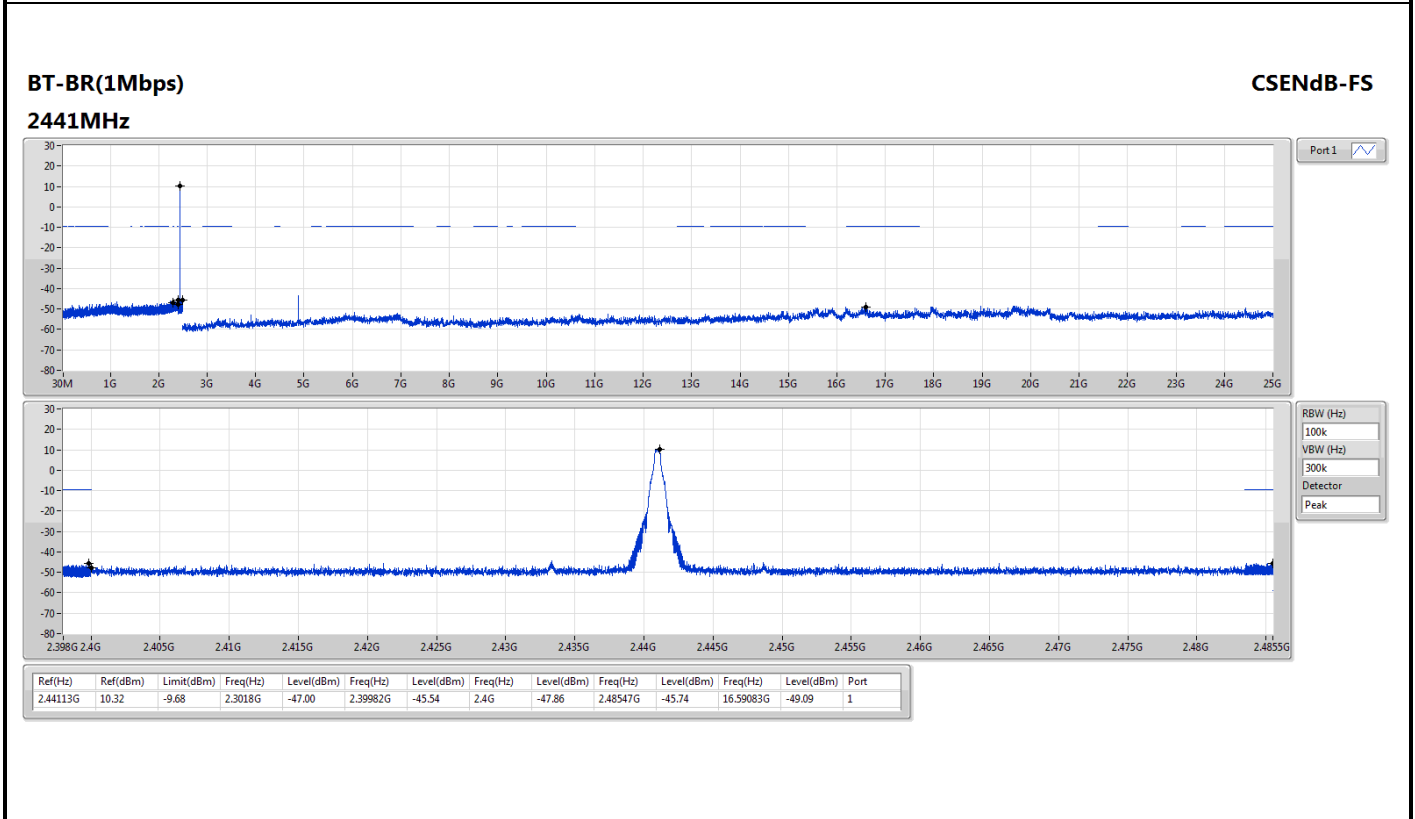
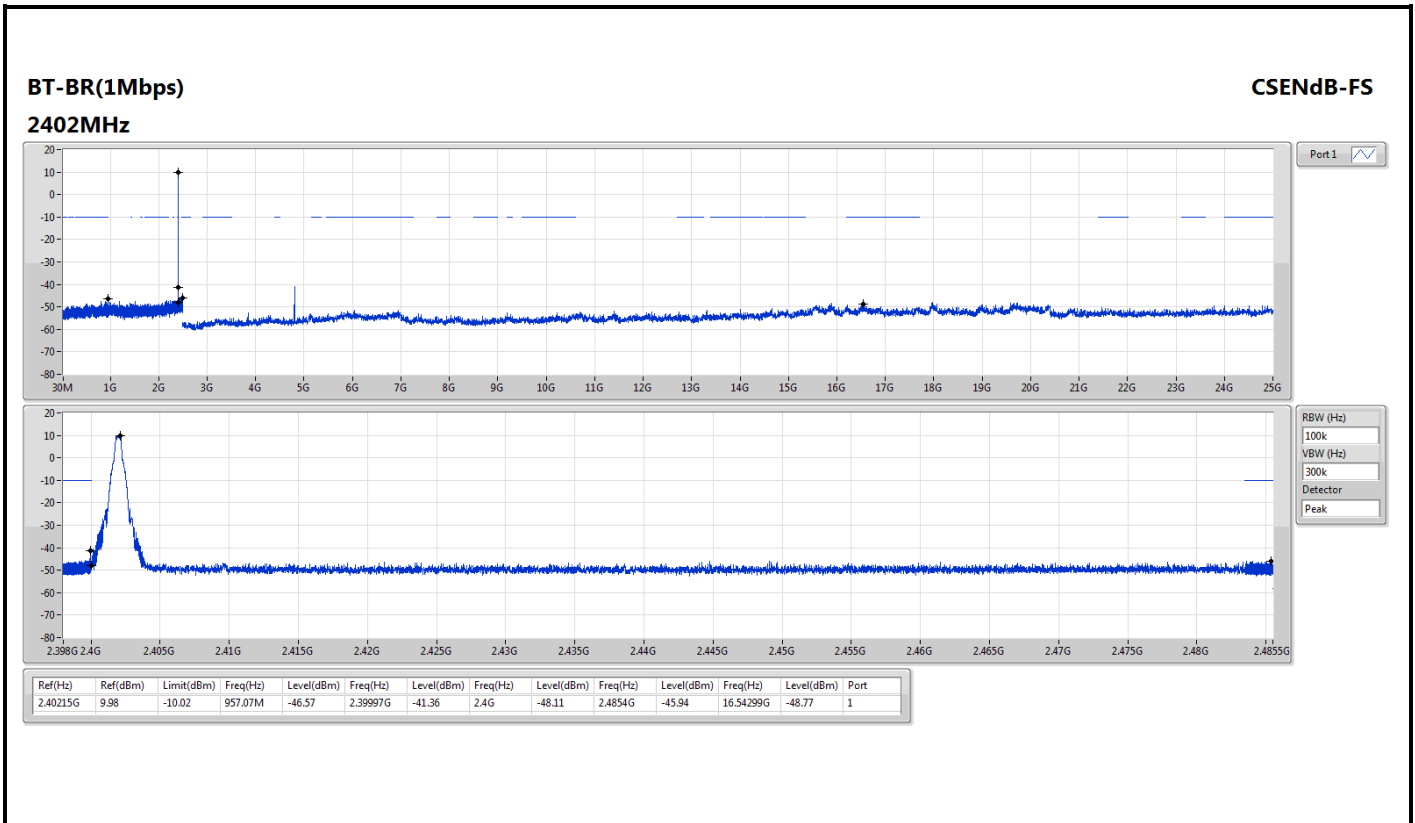

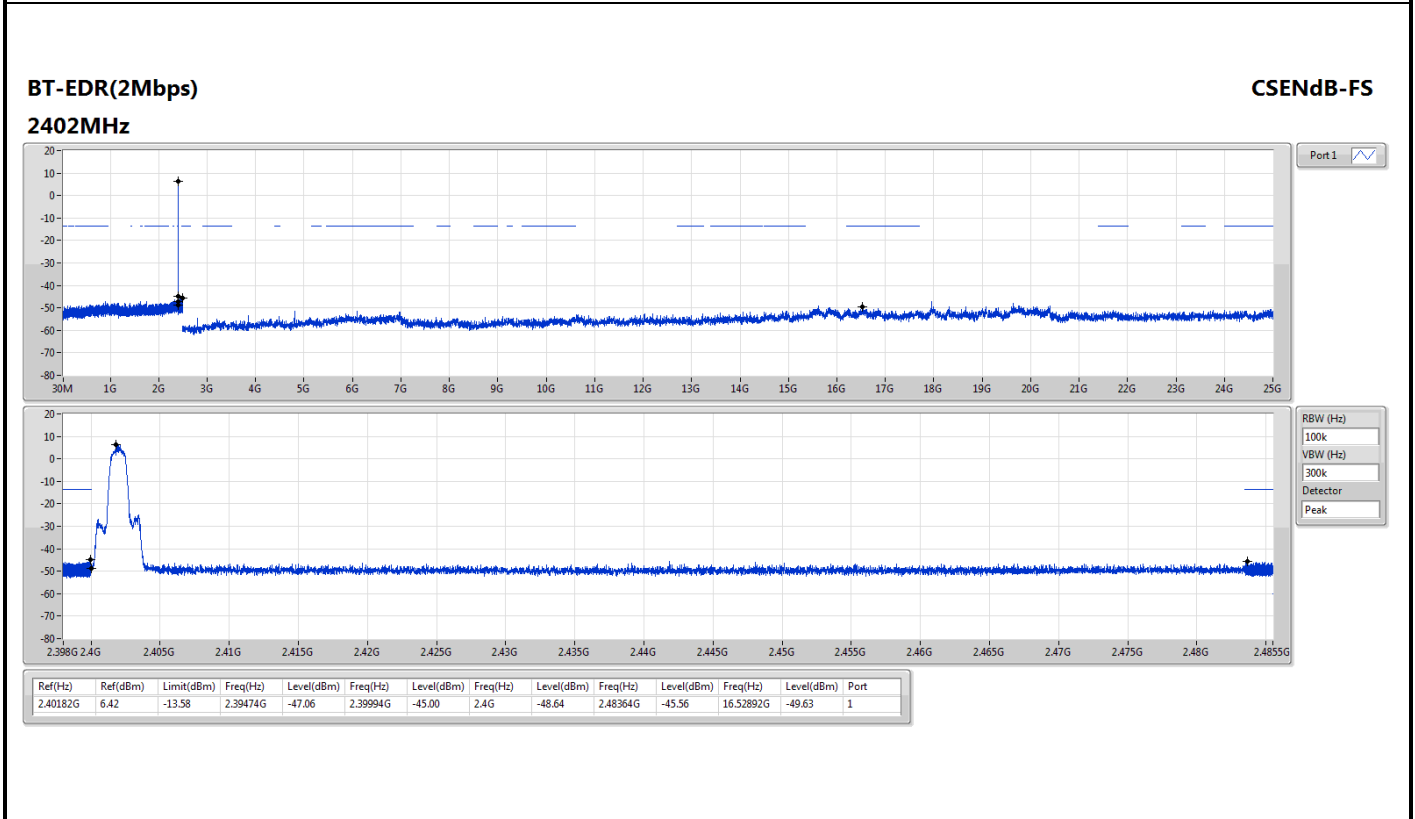
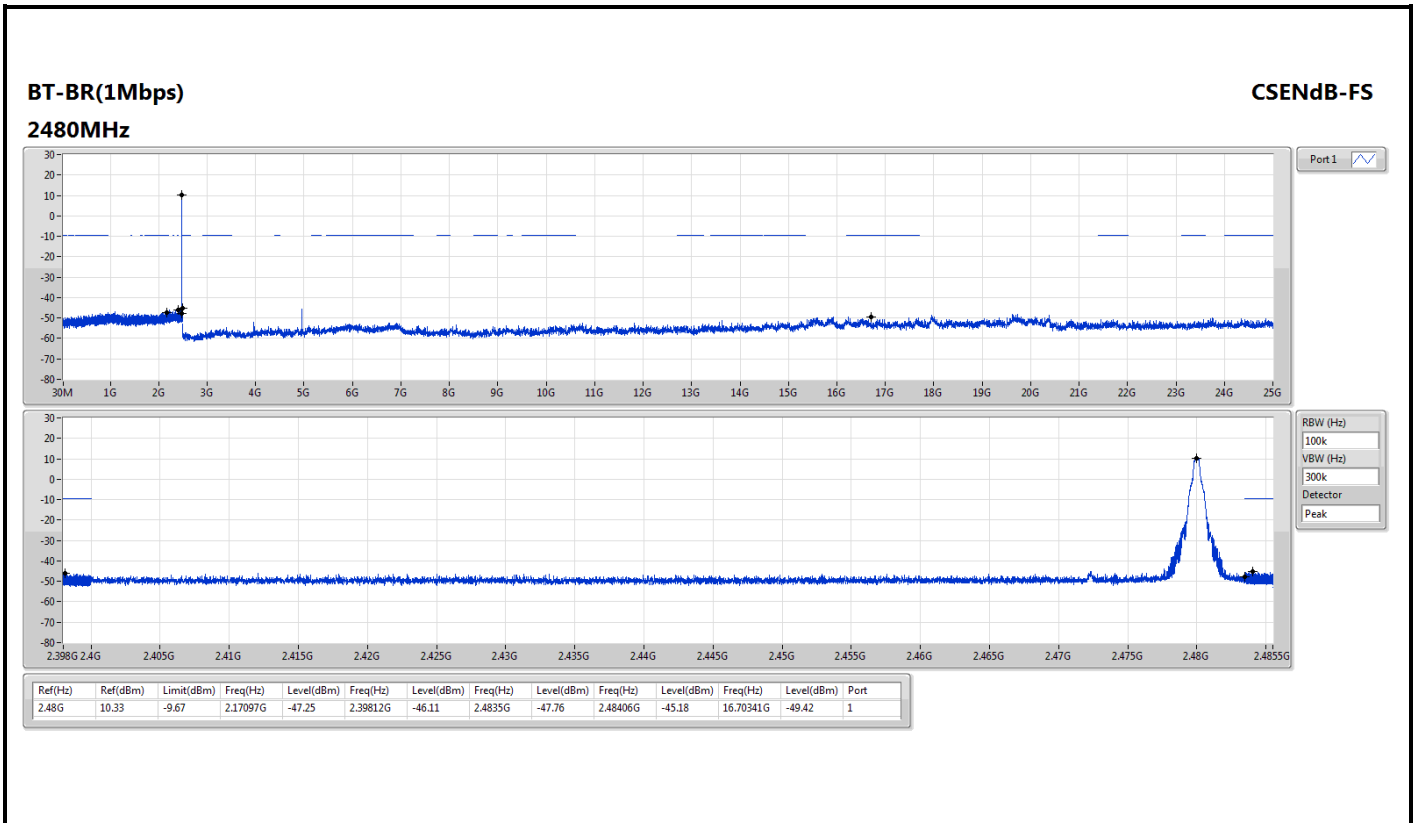

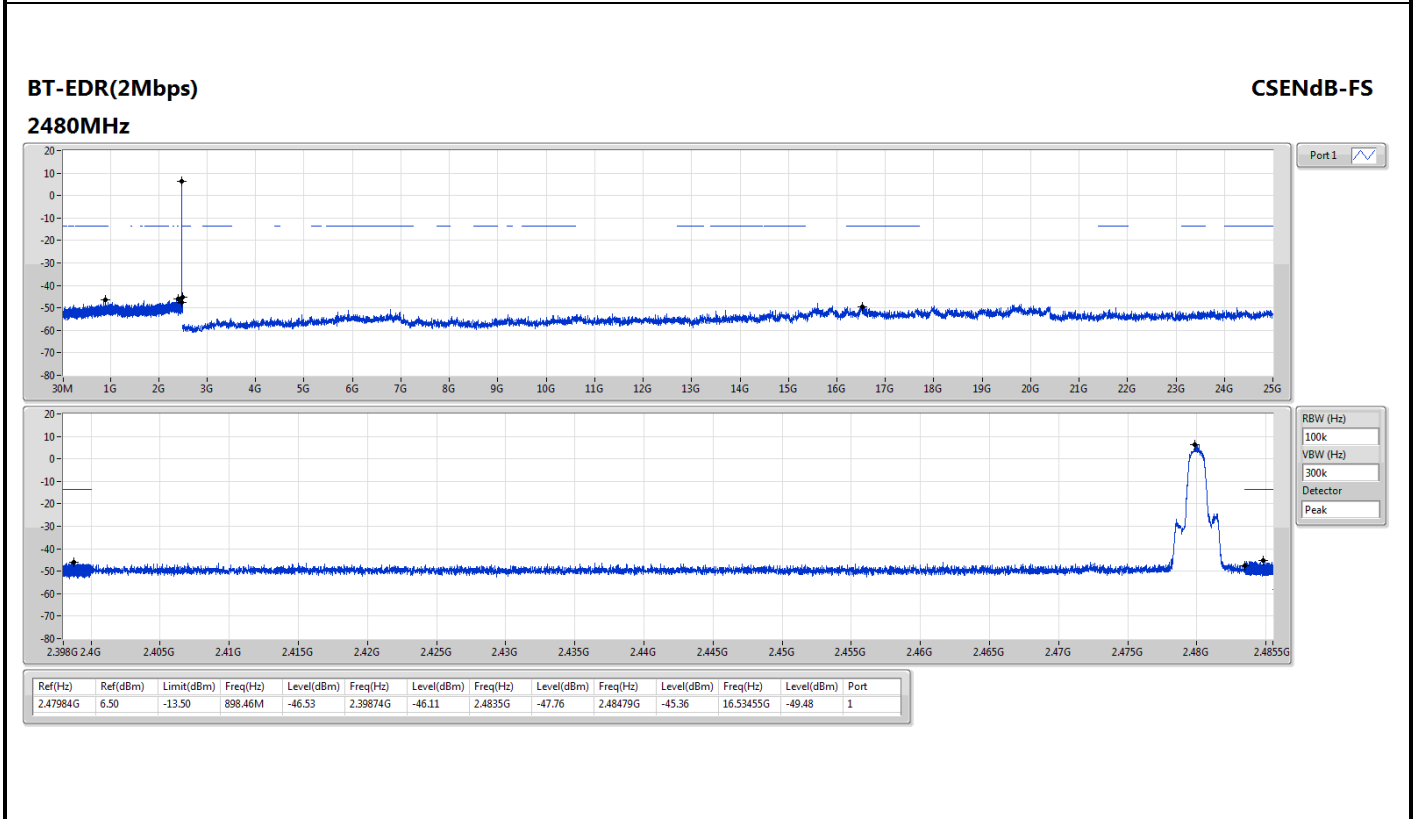
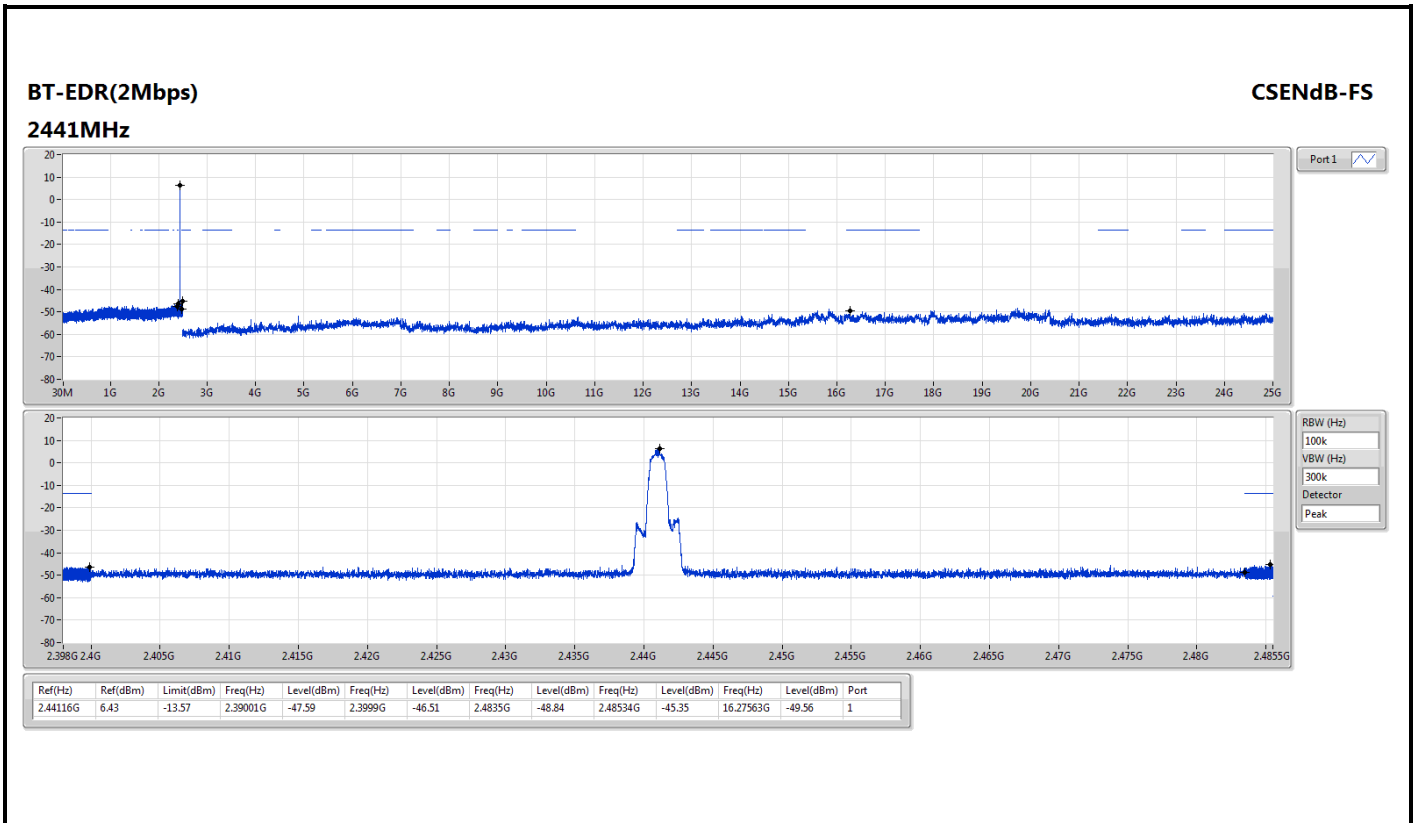

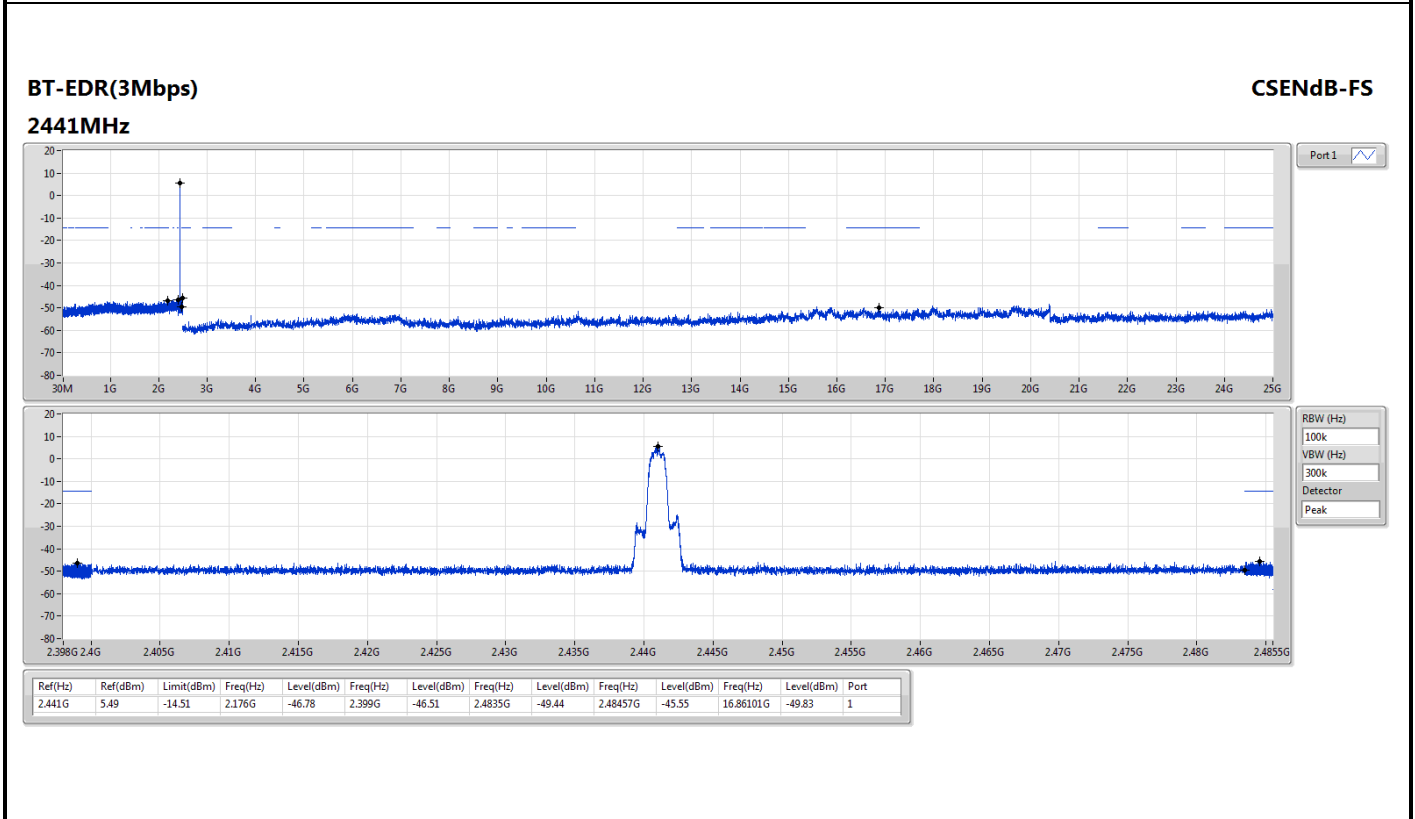
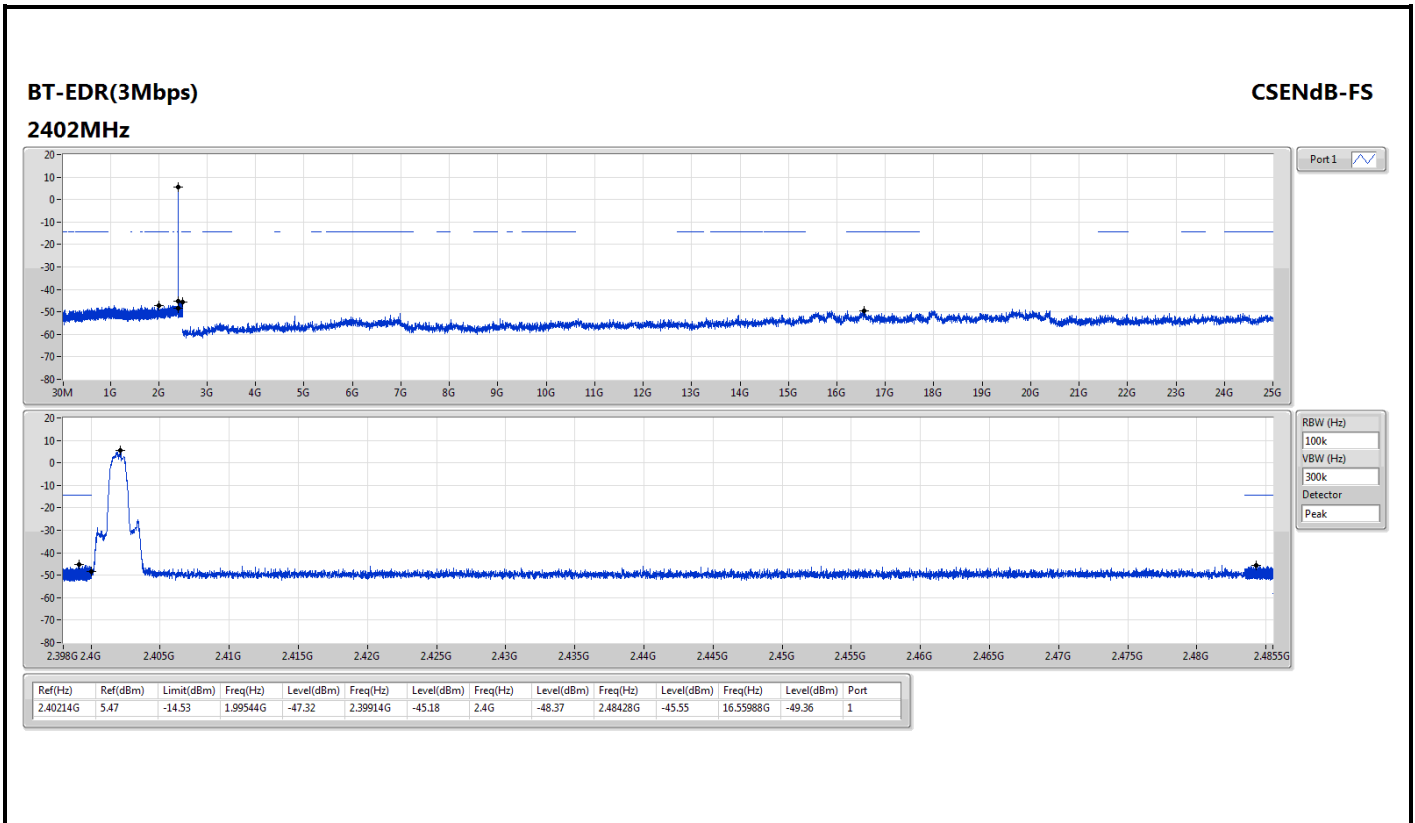

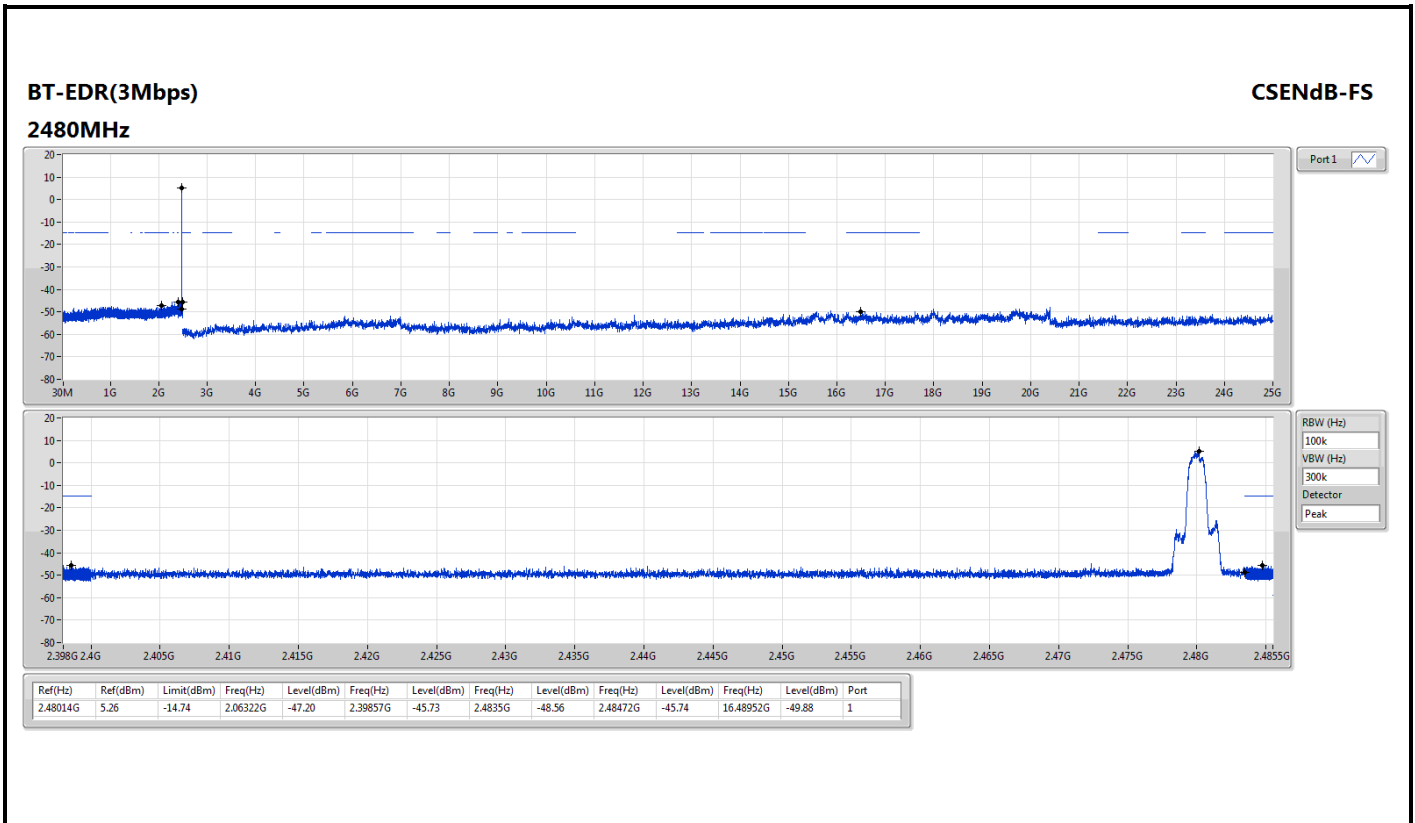

BT-BR(1Mbps)

2402MHz

Hopping Ch Bandedge (Non-restricted Band)

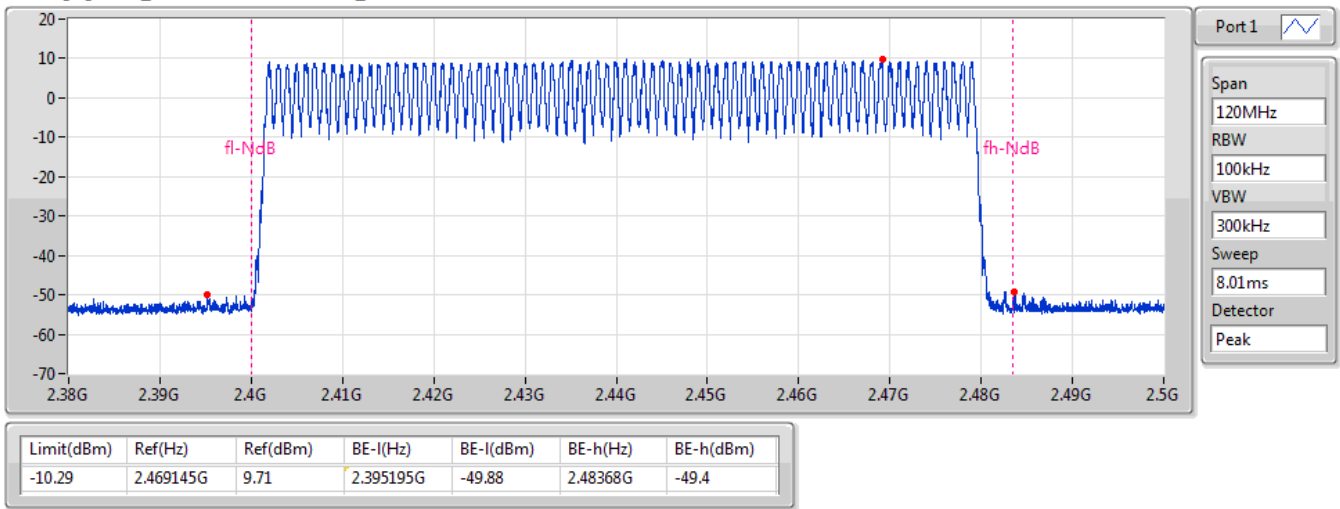

BT-EDR(2Mbps)

2402MHz

Hopping Ch Bandedge (Non-restricted Band)

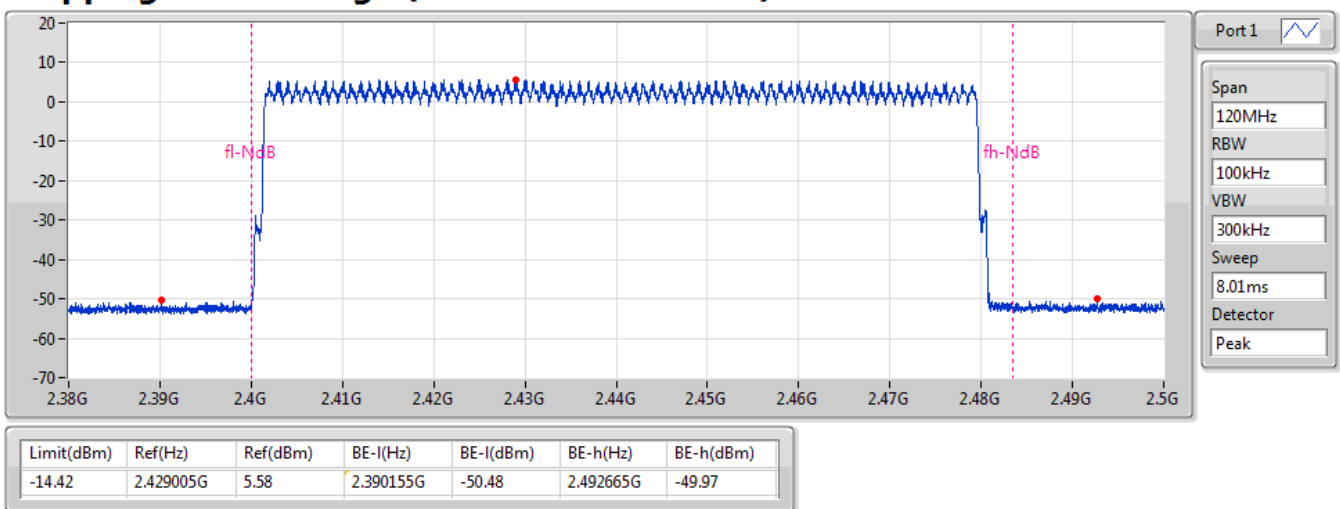

BT-EDR(3Mbps)

2402MHz

Hopping Ch Bandedge (Non-restricted Band)

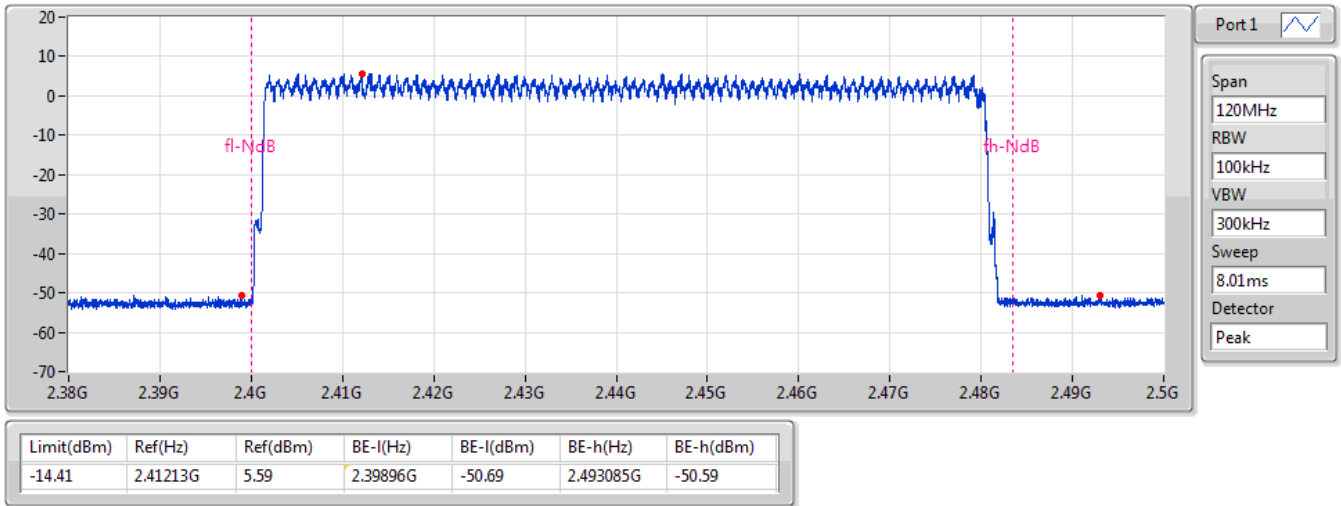

**Summary**

Mode	Power (dBm)	Power (W)
2.4-2.4835GHz	-	-
BT-BR(1Mbps)	10.98	0.01253
BT-EDR(2Mbps)	7.45	0.00556
BT-EDR(3Mbps)	7.47	0.00558

Result

Mode	Result	Antenna Gain (dBi)	Power (dBm)	Power Limit (dBm)
BT-BR(1Mbps)	-	-	-	-
2402MHz	Pass	2.03	10.34	-
2441MHz	Pass	2.03	10.74	-
2480MHz	Pass	2.03	10.98	-
BT-EDR(2Mbps)	-	-	-	-
2402MHz	Pass	2.03	6.69	-
2441MHz	Pass	2.03	7.16	-
2480MHz	Pass	2.03	7.45	-
BT-EDR(3Mbps)	-	-	-	-
2402MHz	Pass	2.03	6.72	-
2441MHz	Pass	2.03	7.18	-
2480MHz	Pass	2.03	7.47	-

Note: Average power is for reference only.



Summary

Mode	Power (dBm)	Power (W)
2.4-2.4835GHz	-	-
BT-BR(1Mbps)	11.04	0.01271
BT-EDR(2Mbps)	9.46	0.00883
BT-EDR(3Mbps)	9.59	0.00910

Result

Mode	Result	Antenna Gain (dBi)	Power (dBm)	Power Limit (dBm)
BT-BR(1Mbps)	-	-	-	-
2402MHz	Pass	2.03	10.41	21.00
2441MHz	Pass	2.03	10.82	21.00
2480MHz	Pass	2.03	11.04	21.00
BT-EDR(2Mbps)	-	-	-	-
2402MHz	Pass	2.03	8.82	21.00
2441MHz	Pass	2.03	9.26	21.00
2480MHz	Pass	2.03	9.46	21.00
BT-EDR(3Mbps)	-	-	-	-
2402MHz	Pass	2.03	9.02	21.00
2441MHz	Pass	2.03	9.39	21.00
2480MHz	Pass	2.03	9.59	21.00



Summary

Mode	Max-Hop No
2.4-2.4835GHz	-
BT-BR(1Mbps)	79
BT-EDR(2Mbps)	79
BT-EDR(3Mbps)	79

Result

Mode	Result	Hopping No	Limit
BT-BR(1Mbps)	-	-	-
2402MHz	Pass	79	15
BT-EDR(2Mbps)	-	-	-
2402MHz	Pass	79	15
BT-EDR(3Mbps)	-	-	-
2402MHz	Pass	79	15



BT-BR(1Mbps)

Hopping-FS

2402MHz

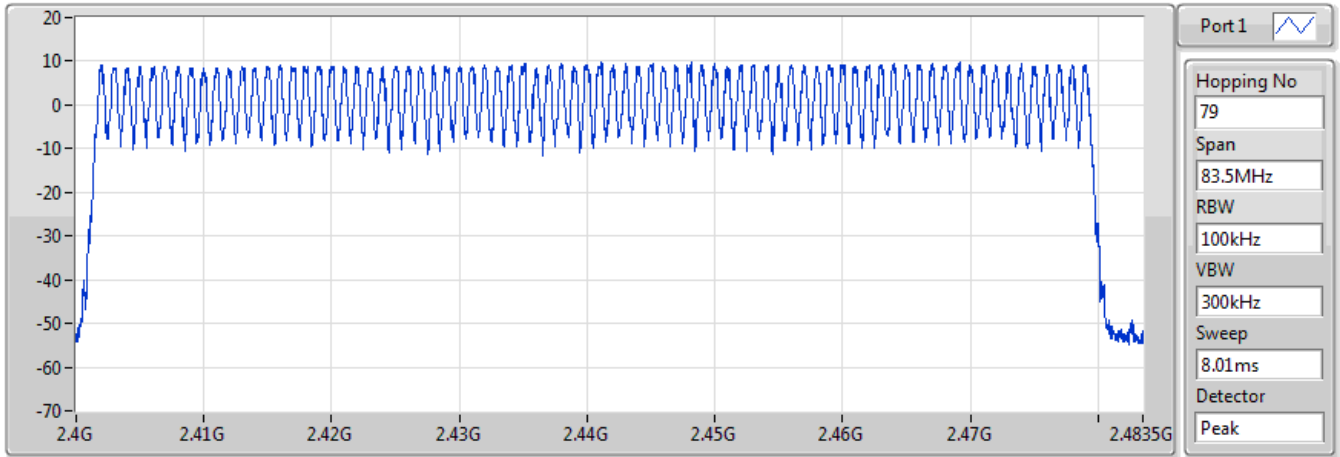

Hopping No	Limit
79	15

BT-EDR(2Mbps)

Hopping-FS

2402MHz

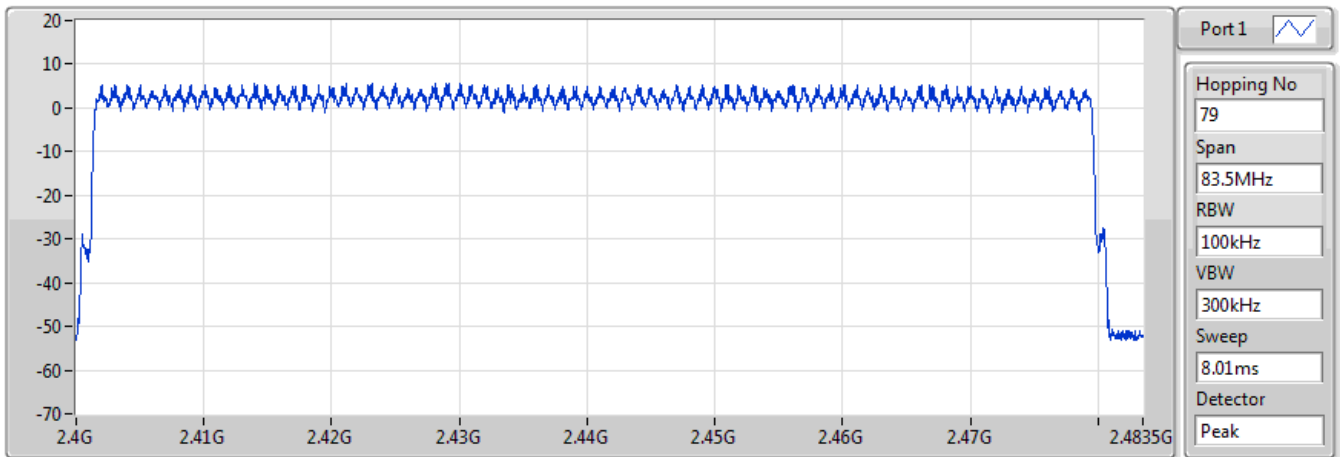

Hopping No	Limit
79	15



BT-EDR(3Mbps)
2402MHz

Hopping-FS

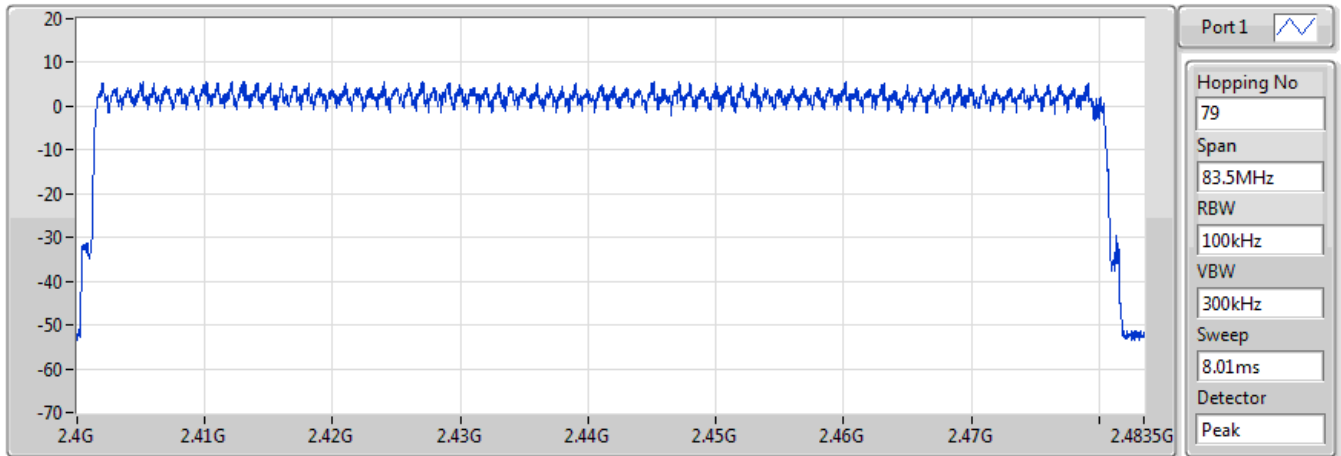

Hopping No	Limit
79	15



Summary

Mode	Max-N dB (Hz)	Max-OBW (Hz)	ITU-Code	Min-N dB (Hz)	Min-OBW (Hz)
2.4-2.4835GHz	-	-	-	-	-
BT-BR(1Mbps)	960.145k	911.722k	912KF1D	938.406k	897.25k
BT-EDR(2Mbps)	1.359M	1.234M	1M23G1D	1.344M	1.223M
BT-EDR(3Mbps)	1.344M	1.23M	1M23G1D	1.341M	1.223M

Max-N dB = Maximum 20dB down bandwidth; Max-OBW = Maximum 99% occupied bandwidth;
Min-N dB = Minimum 20dB down bandwidth; Min-OBW = Minimum 99% occupied bandwidth

Result

Mode	Result	Limit (Hz)	Port 1-N dB (Hz)	Port 1-OBW (Hz)
BT-BR(1Mbps)	-	-	-	-
2402MHz	Pass	Inf	960.145k	900.868k
2441MHz	Pass	Inf	938.406k	897.25k
2480MHz	Pass	Inf	938.406k	911.722k
BT-EDR(2Mbps)	-	-	-	-
2402MHz	Pass	Inf	1.355M	1.223M
2441MHz	Pass	Inf	1.359M	1.226M
2480MHz	Pass	Inf	1.344M	1.234M
BT-EDR(3Mbps)	-	-	-	-
2402MHz	Pass	Inf	1.341M	1.223M
2441MHz	Pass	Inf	1.344M	1.23M
2480MHz	Pass	Inf	1.341M	1.223M

Port X-N dB = Port X 20dB down bandwidth;
Port X-OBW = Port X 99% occupied bandwidth

BT-BR(1Mbps)

EBW-FS

2402MHz

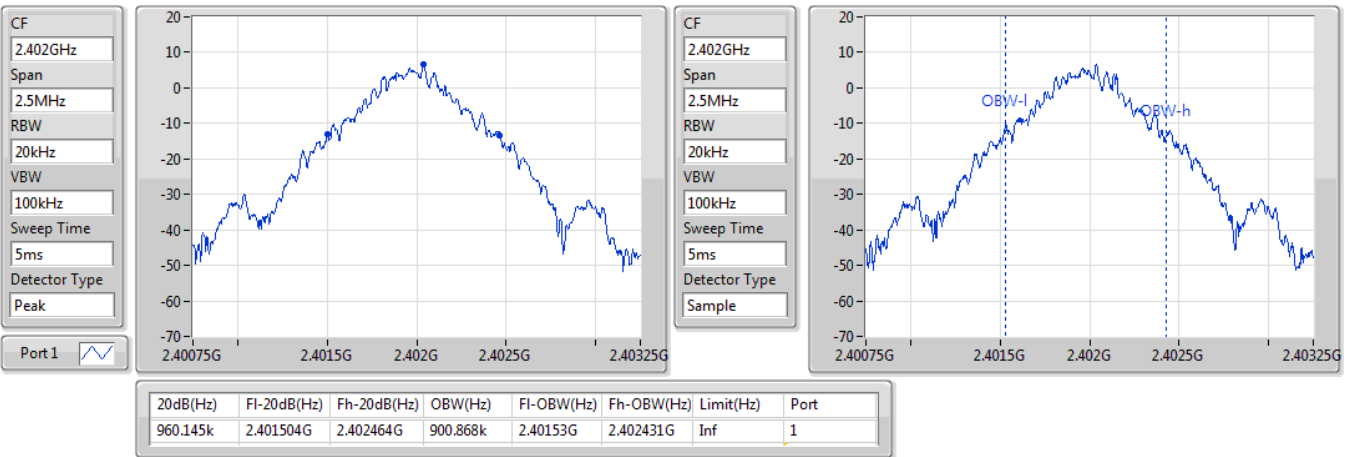

BT-BR(1Mbps)

EBW-FS

2441MHz

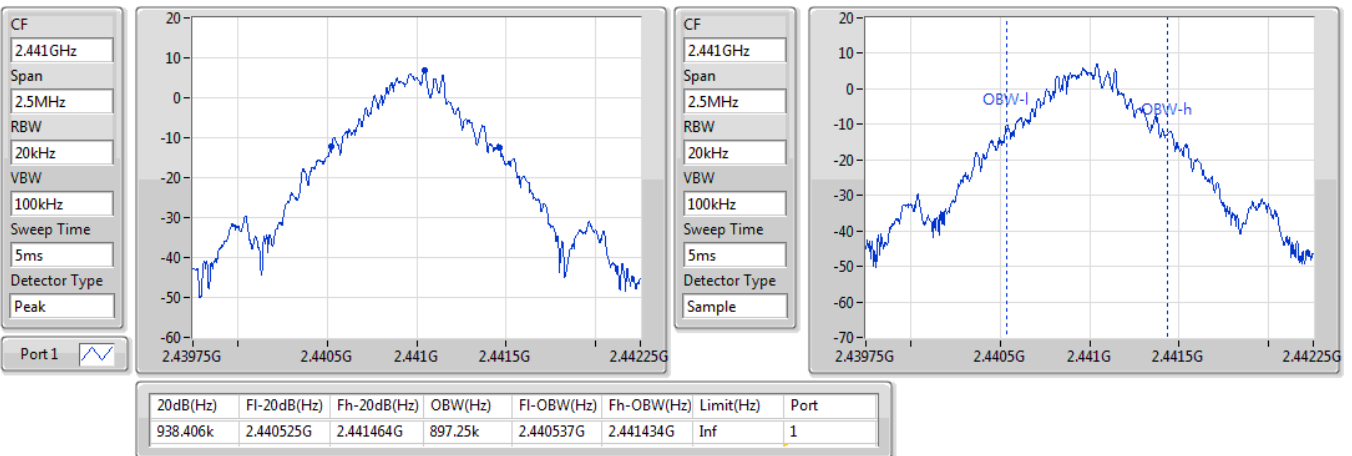

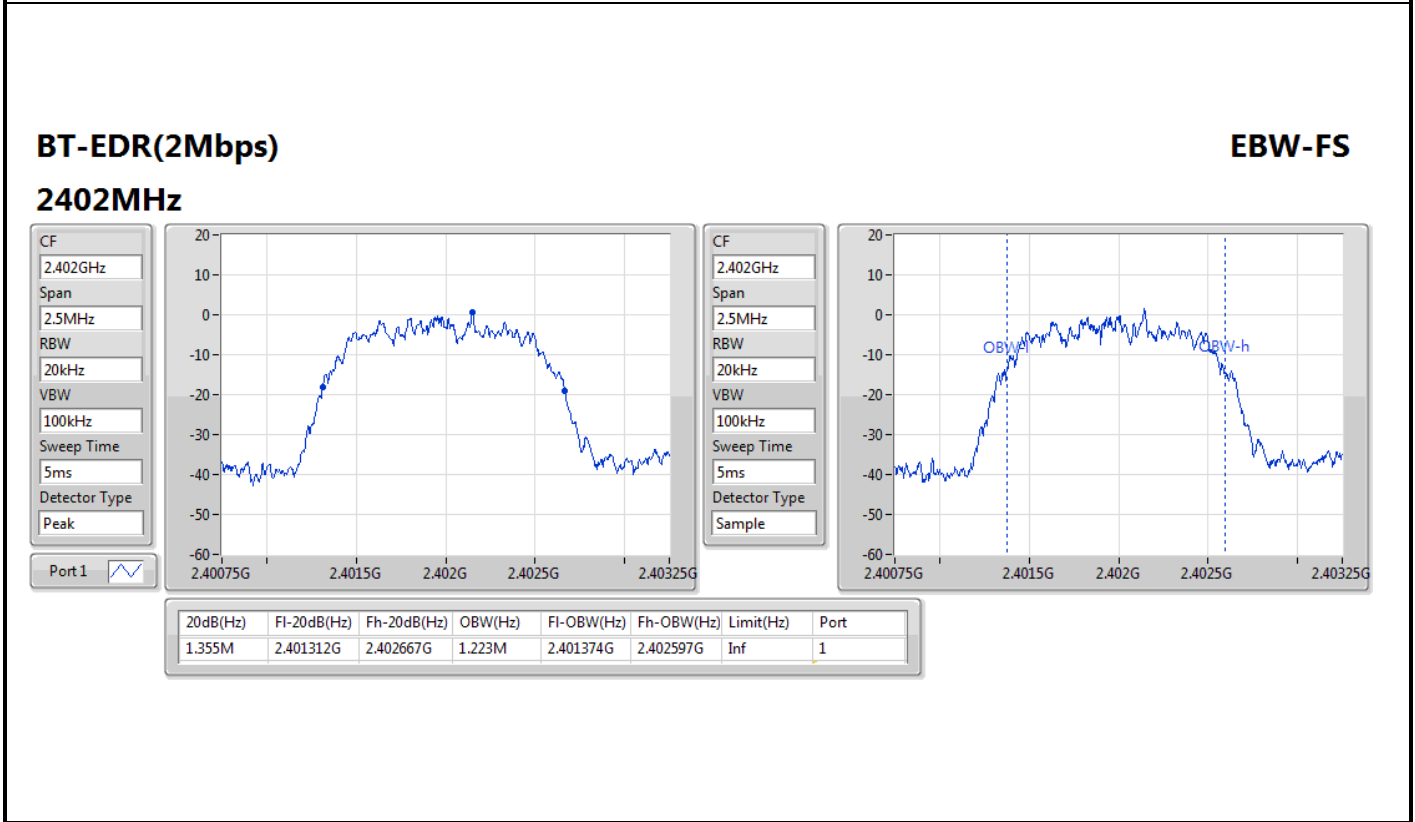
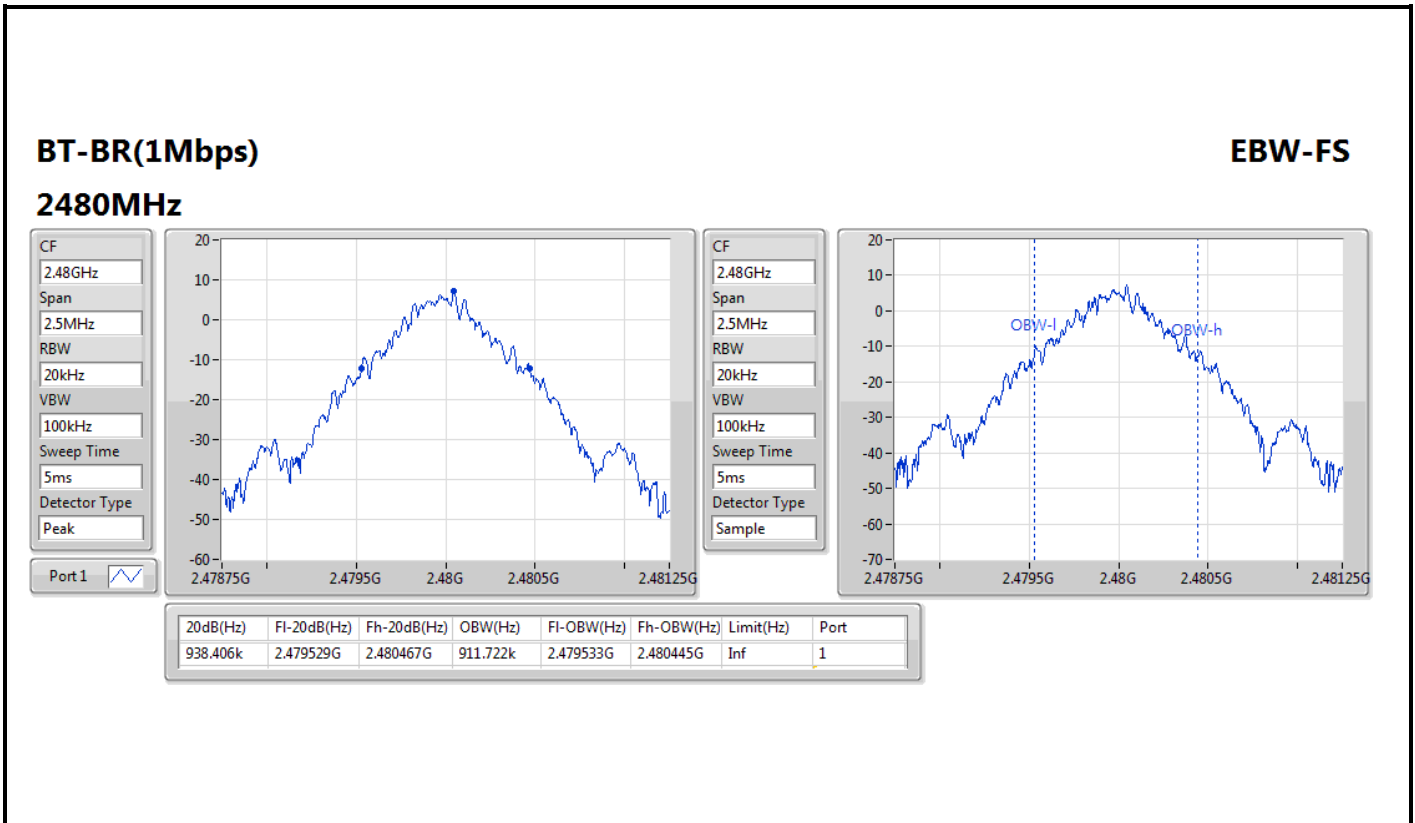



BT-EDR(2Mbps)

EBW-FS

2441MHz

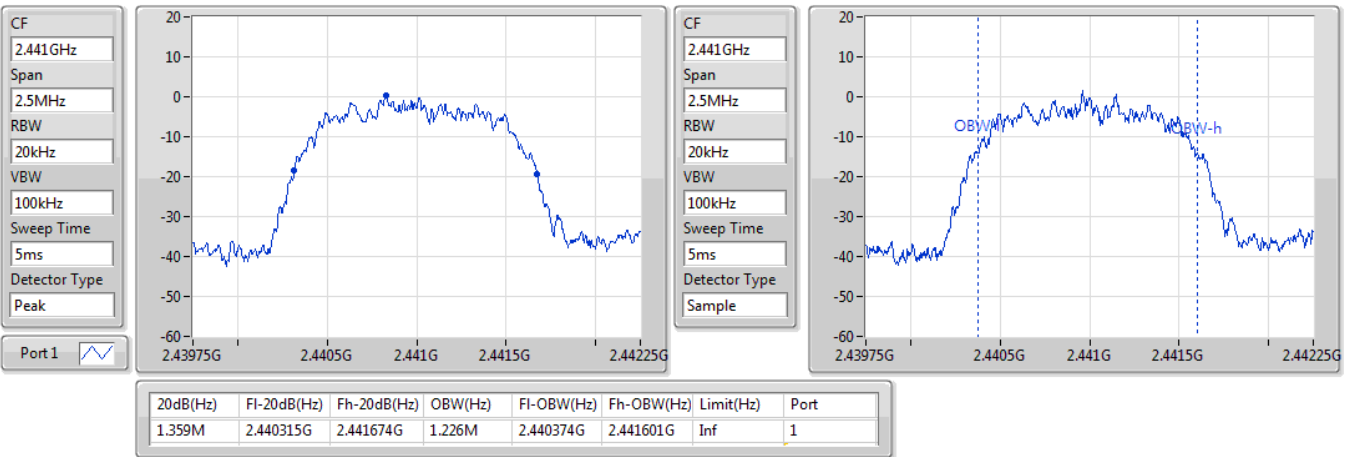

BT-EDR(2Mbps)

EBW-FS

2480MHz

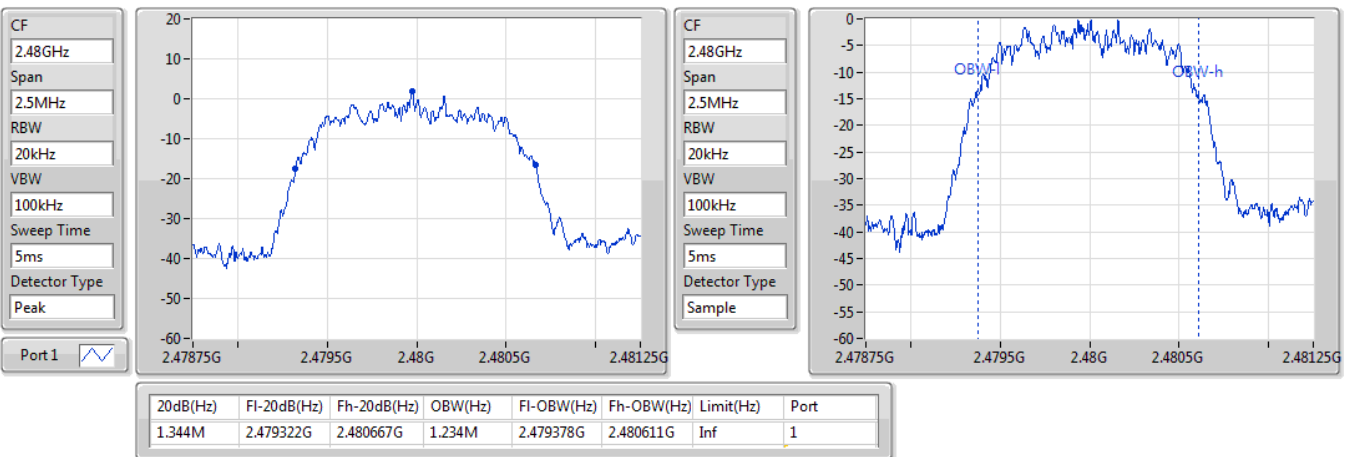

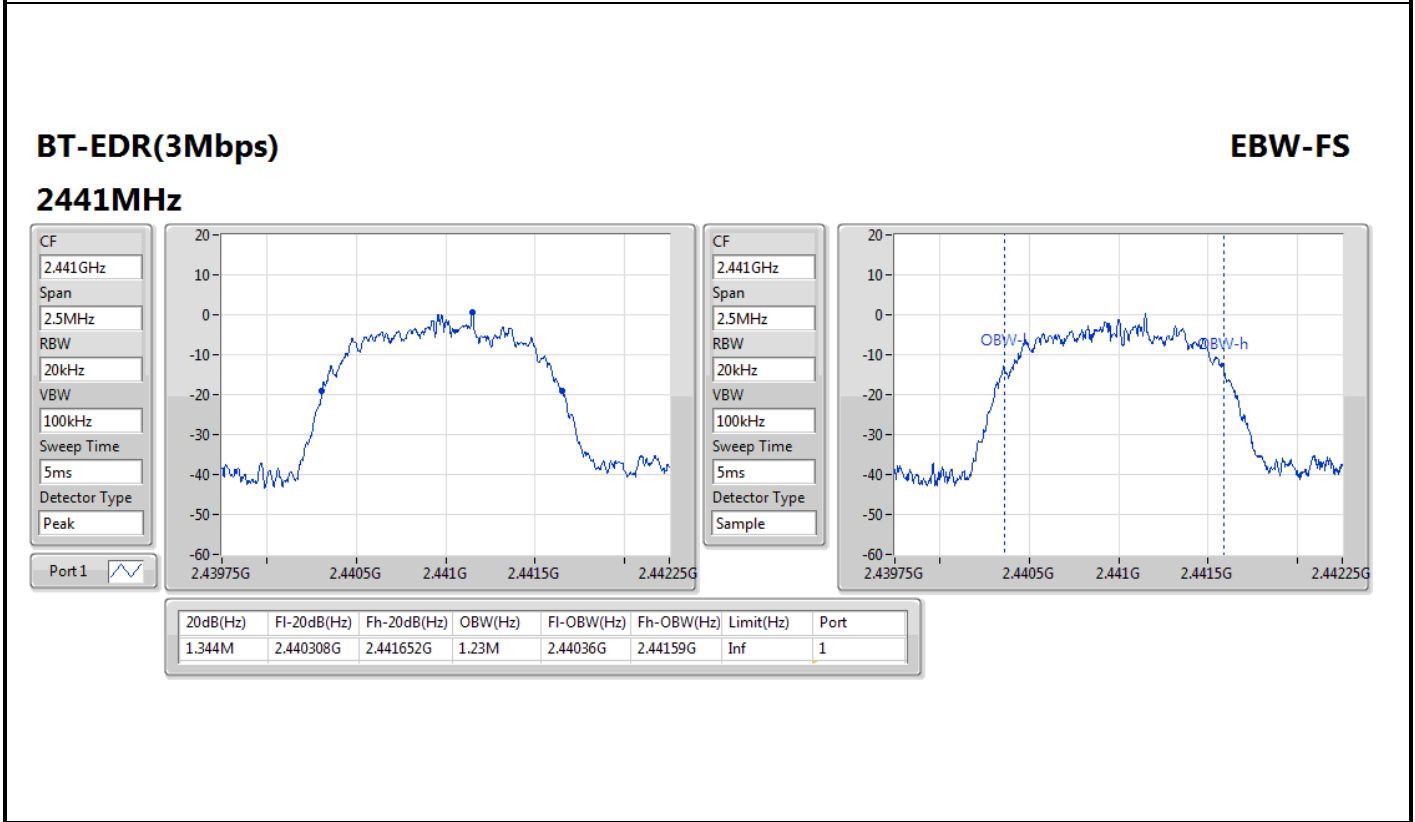
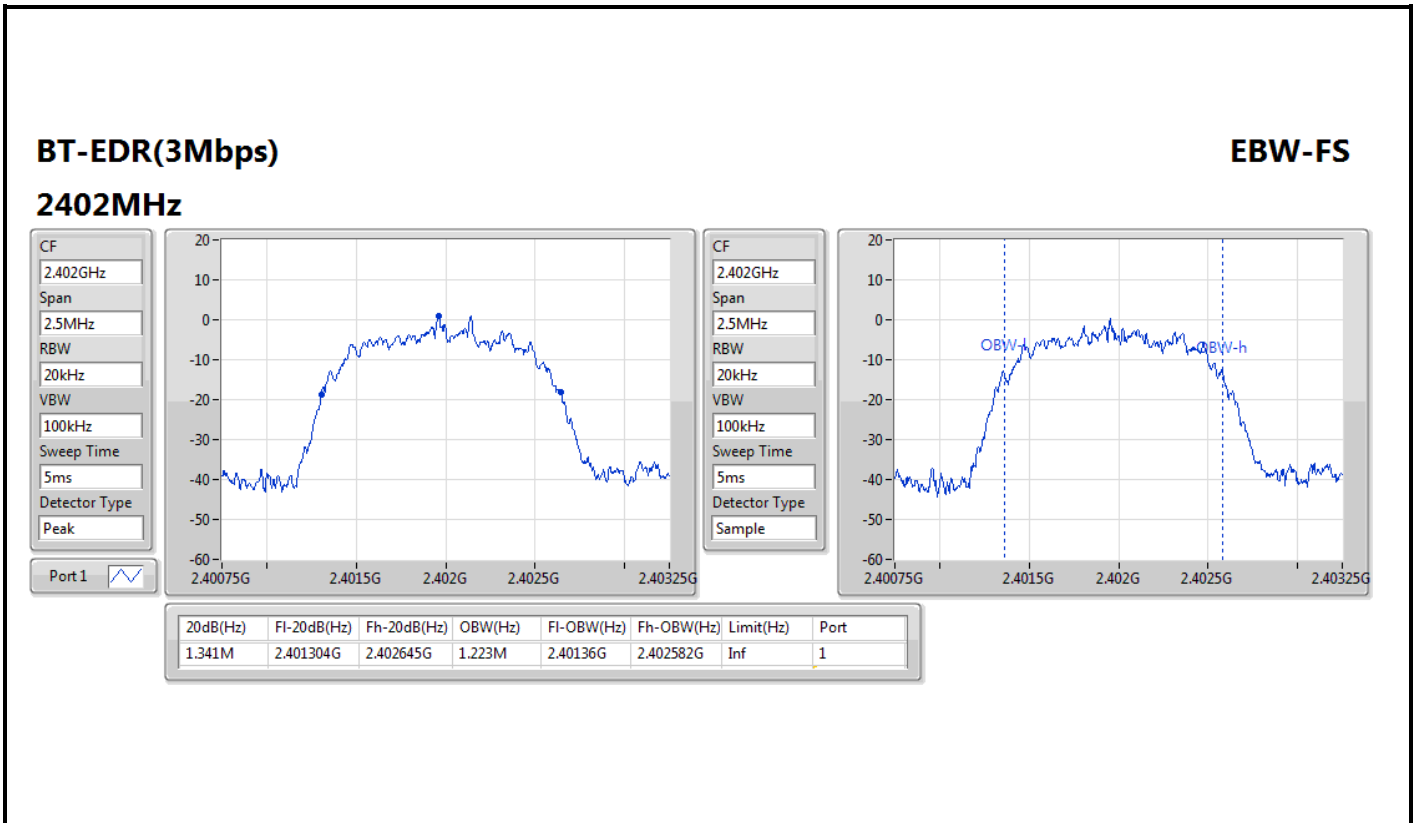

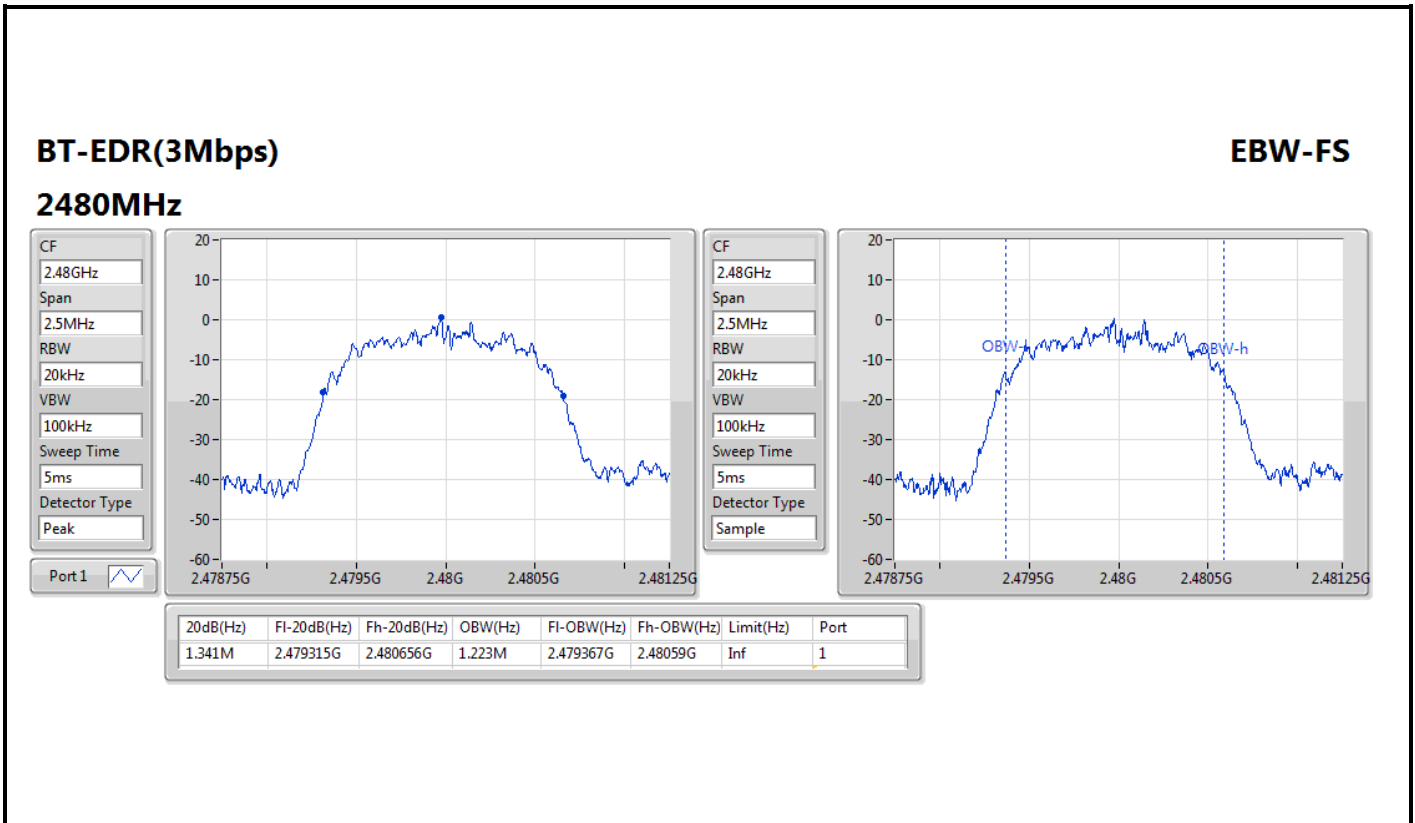



Summary

Mode	Max-Space (Hz)	Min-Space (Hz)
2.4-2.4835GHz	-	-
BT-BR(1Mbps)	1.004348M	1M
BT-EDR(2Mbps)	1.004348M	1M
BT-EDR(3Mbps)	1.004348M	1M

Result

Mode	Result	Fl (Hz)	Fh (Hz)	Ch.Space (Hz)	Limit (Hz)
BT-BR(1Mbps)	-	-	-	-	-
2402MHz	Pass	2.402035G	2.403039G	1.004348M	639.45657k
2441MHz	Pass	2.441043G	2.442043G	1M	624.978396k
2480MHz	Pass	2.479043G	2.480048G	1.004348M	624.978396k
BT-EDR(2Mbps)	-	-	-	-	-
2402MHz	Pass	2.40197G	2.402974G	1.004348M	902.43k
2441MHz	Pass	2.440978G	2.441978G	1M	905.094k
2480MHz	Pass	2.478978G	2.479983G	1.004348M	895.104k
BT-EDR(3Mbps)	-	-	-	-	-
2402MHz	Pass	2.401965G	2.40297G	1.004348M	893.106k
2441MHz	Pass	2.44097G	2.44197G	1M	895.104k
2480MHz	Pass	2.478974G	2.479974G	1M	893.106k



BT-BR(1Mbps)

Channel Separation-FS

2.402G/2.403GHz



BT-BR(1Mbps)

Channel Separation-FS

2.441G/2.442GHz

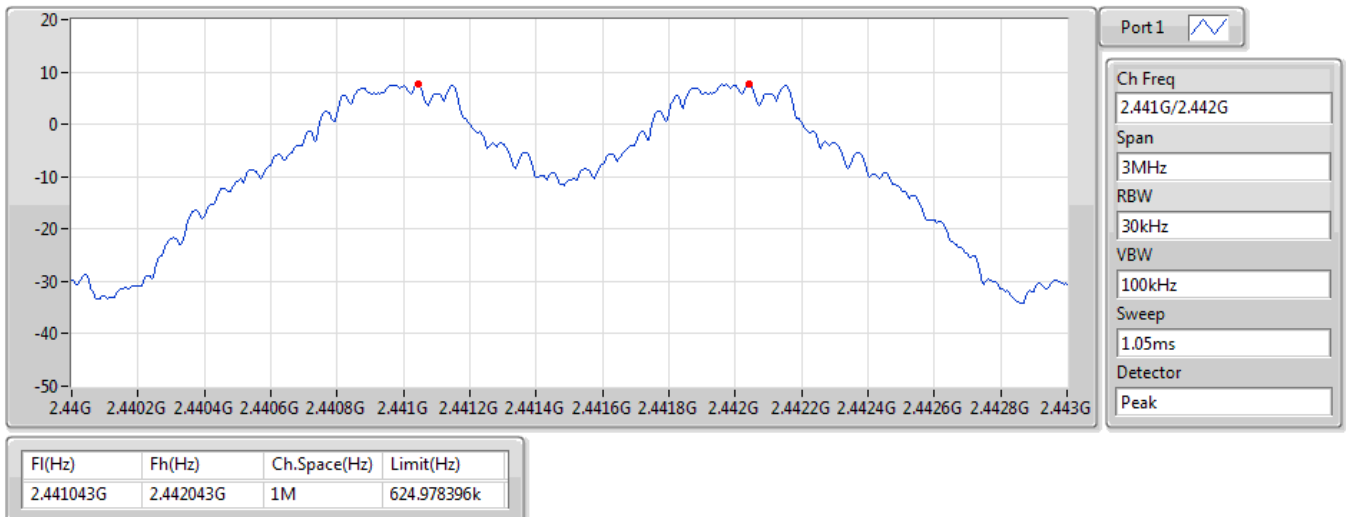



BT-BR(1Mbps)

Channel Separation-FS

2.48G/2.479GHz



Port 1

Ch Freq
2.48G/2.479G

Span
3MHz

RBW
30kHz

VBW
100kHz

Sweep
1.05ms

Detector
Peak

F1(Hz)	Fh(Hz)	Ch.Space(Hz)	Limit(Hz)
2.479043G	2.480048G	1.004348M	624.978396k

BT-EDR(2Mbps)

Channel Separation-FS

2.402G/2.403GHz

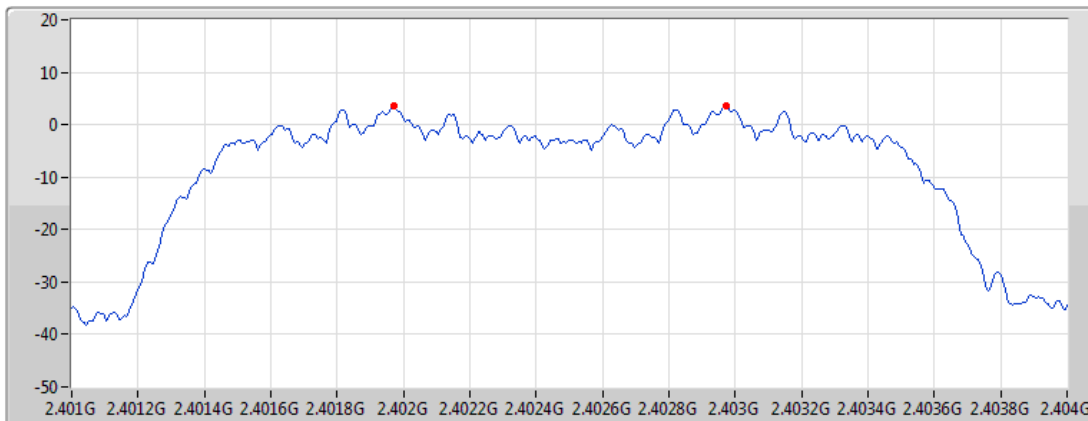

Port 1

Ch Freq
2.402G/2.403G

Span
3MHz

RBW
30kHz

VBW
100kHz

Sweep
1.05ms

Detector
Peak

F1(Hz)	Fh(Hz)	Ch.Space(Hz)	Limit(Hz)
2.40197G	2.402974G	1.004348M	902.43k



BT-EDR(2Mbps)

Channel Separation-FS

2.441G/2.442GHz

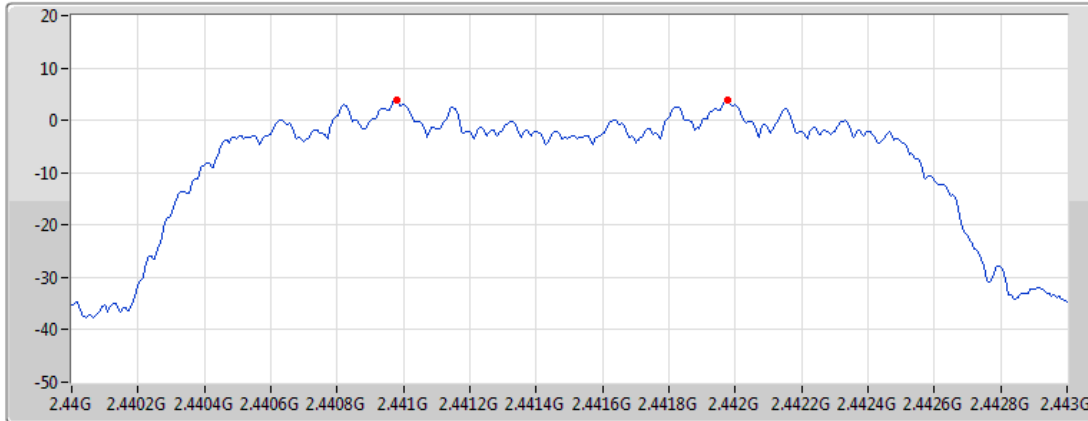

Port 1

Ch Freq
2.441G/2.442G

Span
3MHz

RBW
30kHz

VBW
100kHz

Sweep
1.05ms

Detector
Peak

F1(Hz)	Fh(Hz)	Ch.Space(Hz)	Limit(Hz)
2.440978G	2.441978G	1M	905.094k

BT-EDR(2Mbps)

Channel Separation-FS

2.48G/2.479GHz

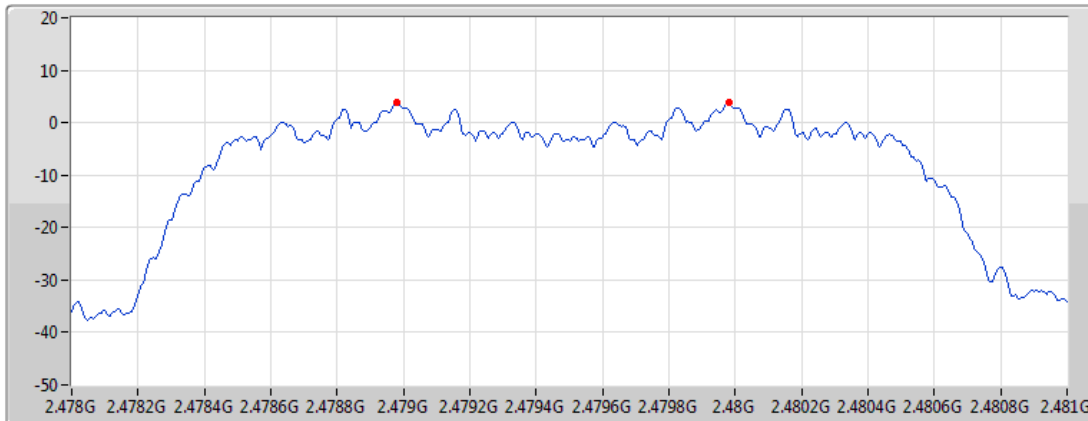

Port 1

Ch Freq
2.48G/2.479G

Span
3MHz

RBW
30kHz

VBW
100kHz

Sweep
1.05ms

Detector
Peak

F1(Hz)	Fh(Hz)	Ch.Space(Hz)	Limit(Hz)
2.478978G	2.479983G	1.004348M	895.104k

BT-EDR(3Mbps)

Channel Separation-FS

2.402G/2.403GHz

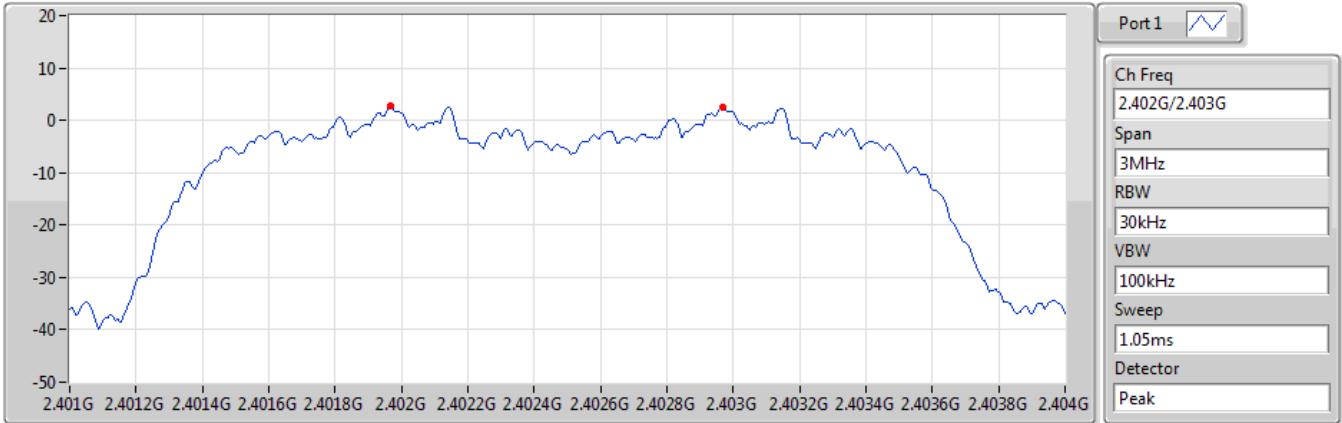

F1(Hz)	Fh(Hz)	Ch.Space(Hz)	Limit(Hz)
2.401965G	2.40297G	1.004348M	893.106k

BT-EDR(3Mbps)

Channel Separation-FS

2.441G/2.442GHz

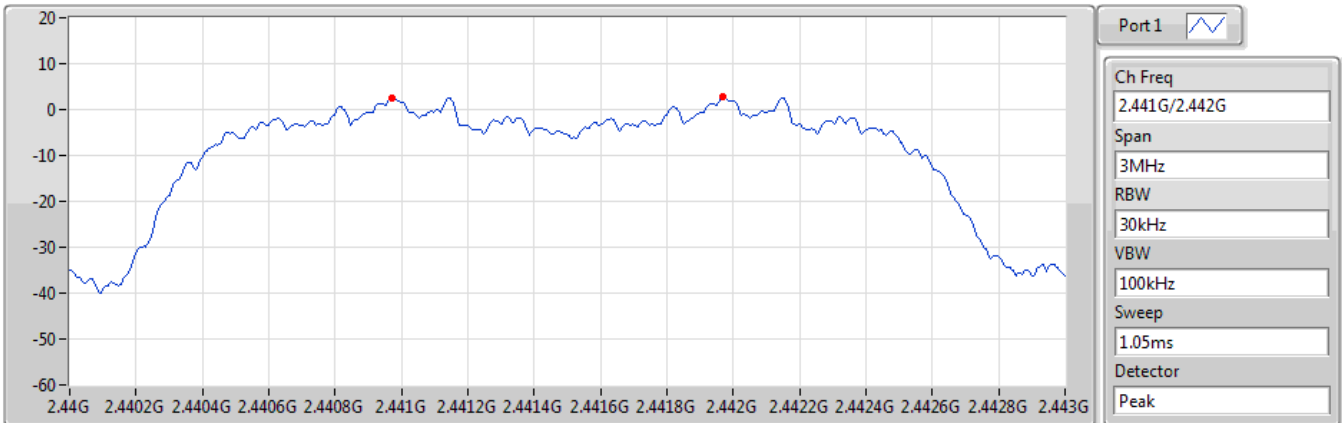

F1(Hz)	Fh(Hz)	Ch.Space(Hz)	Limit(Hz)
2.44097G	2.44197G	1M	895.104k



BT-EDR(3Mbps)

Channel Separation-FS

2.48G/2.479GHz

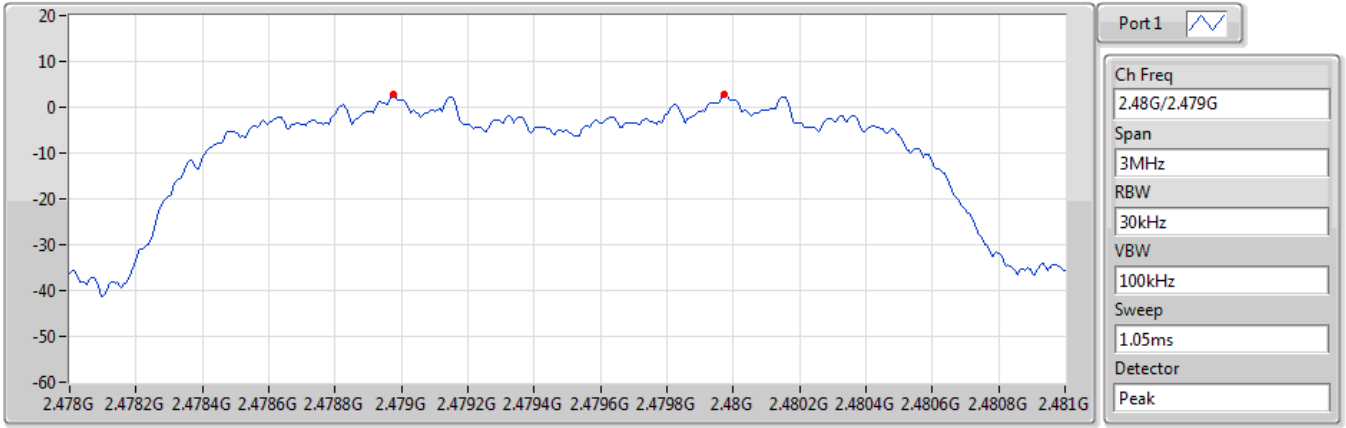

F1(Hz)	Fh(Hz)	Ch.Space(Hz)	Limit(Hz)
2.478974G	2.479974G	1M	893.106k



Summary

Mode	Max-Dwell (s)
2.4-2.4835GHz	-
BT-BR(1Mbps)	329.96088m_DH5
BT-EDR(2Mbps)	348.44214m_DH5
BT-EDR(3Mbps)	312.05948m_DH5
BT-BR-AFH(1Mbps)	313.254m_DH5-AFH
BT-EDR-AFH(2Mbps)	313.47m_DH5-AFH
BT-EDR-AFH(3Mbps)	313.686m_DH5-AFH



Result/ Non AFH mode

Mode	Result	Period (s)	Dwell (s)	Limit (s)	Tx On (ms)	Number of transmission in a 5 s
BT-BR(1Mbps)	-	-	-	-	-	-
2402MHz_DH5	PASS	31.6	0.32996	0.4	2.90050	18
BT-EDR(2Mbps)	-	-	-	-	-	-
2402MHz_DH5	PASS	31.6	0.34844	0.4	2.90175	19
BT-EDR(3Mbps)	-	-	-	-	-	-
2402MHz_DH5	PASS	31.6	0.31206	0.4	2.90450	17

Note 1: Dwell time =Number of transmission in a 5 second x Tx On
Time x 6.32

Note 2: DH5 was the worst mode.

Result/ AFH mode

Mode	Result	Period (s)	Dwell (s)	Limit (s)	Tx On (ms)	Number of transmission in a 2 s
BT-BR-AFH(1Mbps)	-	-	-	-	-	-
2402MHz_DH5	PASS	8	0.31325	0.4	2.90050	27
BT-EDR-AFH(2Mbps)	-	-	-	-	-	-
2402MHz_DH5	PASS	8	0.31347	0.4	2.90250	27
BT-EDR-AFH(3Mbps)	-	-	-	-	-	-
2402MHz_DH5	PASS	8	0.31369	0.4	2.90450	27

Note 1: Dwell time =Number of transmission in a 2 second x Tx On
Time x 4

Note 2: DH5 was the worst mode.



BT-BR(1Mbps)

Dwell-FS

2402MHz

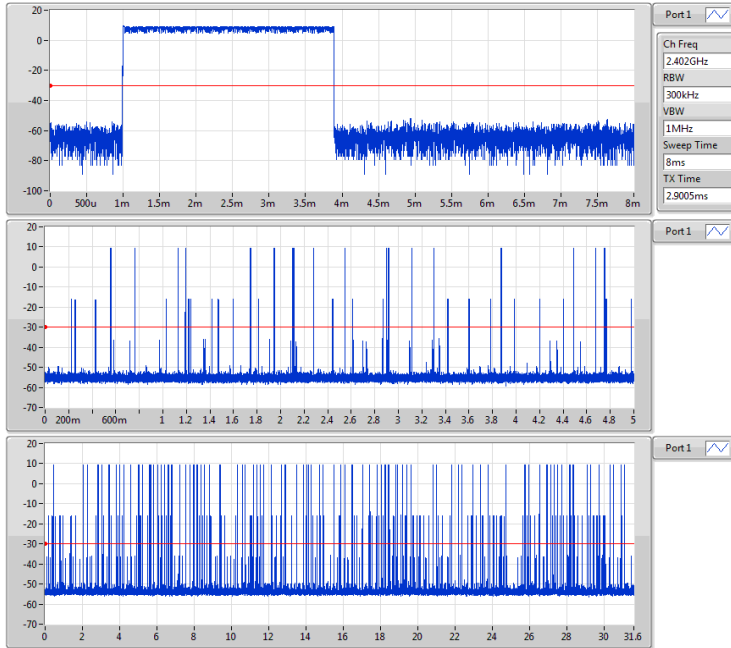

BT-EDR(2Mbps)

Dwell-FS

2402MHz

