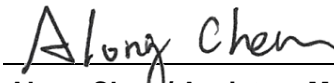

FCC Test Report

FCC ID : IPH-03942
Equipment : Marine Stereo
Model No. : A03942
Brand Name : FUSION
Applicant : Garmin International, Inc.
Address : 1200 E. 151st Street Olathe, KS 66062 United States
Standard : 47 CFR FCC Part 15.249
Received Date : Oct. 27, 2020
Tested Date : Nov. 04 ~ Nov. 10, 2020

We, International Certification Corporation, would like to declare that the tested sample has been evaluated and in compliance with the requirement of the above standards. The test results contained in this report refer exclusively to the product. It may be duplicated completely for legal use with the approval of the applicant. It shall not be reproduced except in full without the written approval of our laboratory.

Reviewed by:

Along Chen / Assistant Manager

Approved by:

Gary Chang / Manager



Table of Contents

| | | |
|----------|---|-----------|
| 1 | GENERAL DESCRIPTION | 5 |
| 1.1 | Information..... | 5 |
| 1.2 | Local Support Equipment List | 6 |
| 1.3 | Test Setup Chart | 7 |
| 1.4 | The Equipment List | 8 |
| 1.5 | Test Standards | 9 |
| 1.6 | Deviation from Test Standard and Measurement Procedure..... | 9 |
| 1.7 | Measurement Uncertainty | 9 |
| 2 | TEST CONFIGURATION..... | 10 |
| 2.1 | Testing Facility | 10 |
| 2.2 | The Worst Test Modes and Channel Details | 10 |
| 3 | TRANSMITTER TEST RESULTS | 11 |
| 3.1 | Radiated Emission | 11 |
| 3.2 | 20dB and Occupied Bandwidth..... | 19 |
| 4 | TEST LABORATORY INFORMATION | 20 |

Release Record

| Report No. | Version | Description | Issued Date |
|------------|---------|---------------|---------------|
| FR002701 | Rev. 01 | Initial issue | Mar. 17, 2021 |

Summary of Test Results

| FCC Rules | Test Items | Measured | Result |
|--|---|-------------------------------|--------|
| 15.207 | AC Power Line Conducted Emissions | Note ¹ | N/A |
| 15.249(a) | Field Strength of Fundamental | Meet the requirement of limit | Pass |
| 15.249(a)(d) | Field Strength of Harmonics and Emissions Radiated outside of the Specified Frequency Bands | Meet the requirement of limit | Pass |
| 15.215(c) | 20dB bandwidth | Meet the requirement of limit | Pass |
| 15.203 | Antenna Requirement | Meet the requirement of limit | Pass |
| N/A means Not Applicable. Note ¹ : The EUT consumes DC power, so the test is not required. | | | |

Declaration of Conformity:

The test results with all measurement uncertainty excluded are presented in accordance with the regulation limits or requirements declared by manufacturers.

Comments and Explanations:

The declared of product specification for EUT presented in the report are provided by the manufacturer, and the manufacturer takes all the responsibilities for the accuracy of product specification.

1 General Description

1.1 Information

1.1.1 Specification of the Equipment under Test (EUT)

| RF General Information | | | | |
|------------------------|------------|-----------------|----------------|-----------|
| Frequency Range (MHz) | Modulation | Ch. Freq. (MHz) | Channel Number | Data Rate |
| 2460 | GFSK | 2460 | 1 [1] | 1 Mbps |

1.1.2 Antenna Details

| Ant. No. | Type | Gain (dBi) | Connector | Remark |
|----------|------|------------|-----------|--------|
| 1 | PIFA | 1.7 | N/A | --- |

1.1.3 Power Supply Type of Equipment under Test (EUT)

| | |
|--------------------------|-------|
| Power Supply Type | 12Vdc |
|--------------------------|-------|

1.1.4 Accessories

| Accessories | | |
|-------------|------------------|--|
| No. | Equipment | Description |
| 1 | Power cable | Brand: FUSION Model: Ca Assy, A Port, PWR/SPKR W/O IGTN & Telemute, FusConn Power Line: 0.2m non-shielded without core |
| 2 | Audio cable (x2) | Brand: FUSION Model: Ca Assy, B Port, RCA, Zone 1 L/R/S, Aux, FusConn Line: 0.2m shielded without core |

1.1.5 Test Tool and Duty Cycle

| | | |
|-----------------------------------|-----------------------|-------------------------|
| Test Tool | north_iop_gui,v0.2 | |
| Duty Cycle and Duty Factor | Duty Cycle (%) | Duty Factor (dB) |
| | 100 | 0 |

1.2 Local Support Equipment List

| Support Equipment List | | | | | |
|------------------------|--------------------------------|------------|------------|--------|------------------------|
| No. | Equipment | Brand | Model | FCC ID | Remarks |
| 1 | AM/FM ANT | Techbrands | AR-3250 | --- | Provided by applicant. |
| 2 | USB Dongle | Strontium | Pollex 4 G | --- | Provided by applicant. |
| 3 | power cable | FUSION | 842716 | --- | Provided by applicant. |
| 4 | Speaker load (x2) | FUSION | L25J4R0E | --- | Provided by applicant. |
| 5 | Audio cable (AUX In) (x2) | FUSION | H810KFZA | --- | Provided by applicant. |
| 6 | Audio cable (AUX In) (x2) | FUSION | H810KFZA | --- | Provided by applicant. |
| 7 | Audio cable (Line Out) (x6) | FUSION | H810KFZA | --- | Provided by applicant. |
| 8 | Audio cable (Line Out) (x6) | FUSION | H810KFZA | --- | Provided by applicant. |
| 9 | Audio load (x16) | --- | --- | --- | Provided by applicant. |
| 10 | Battery | YUASA | 38B19R | --- | --- |
| 11 | USB cable | FUSION | FUC200 | --- | Provided by applicant. |

1.3 Test Setup Chart

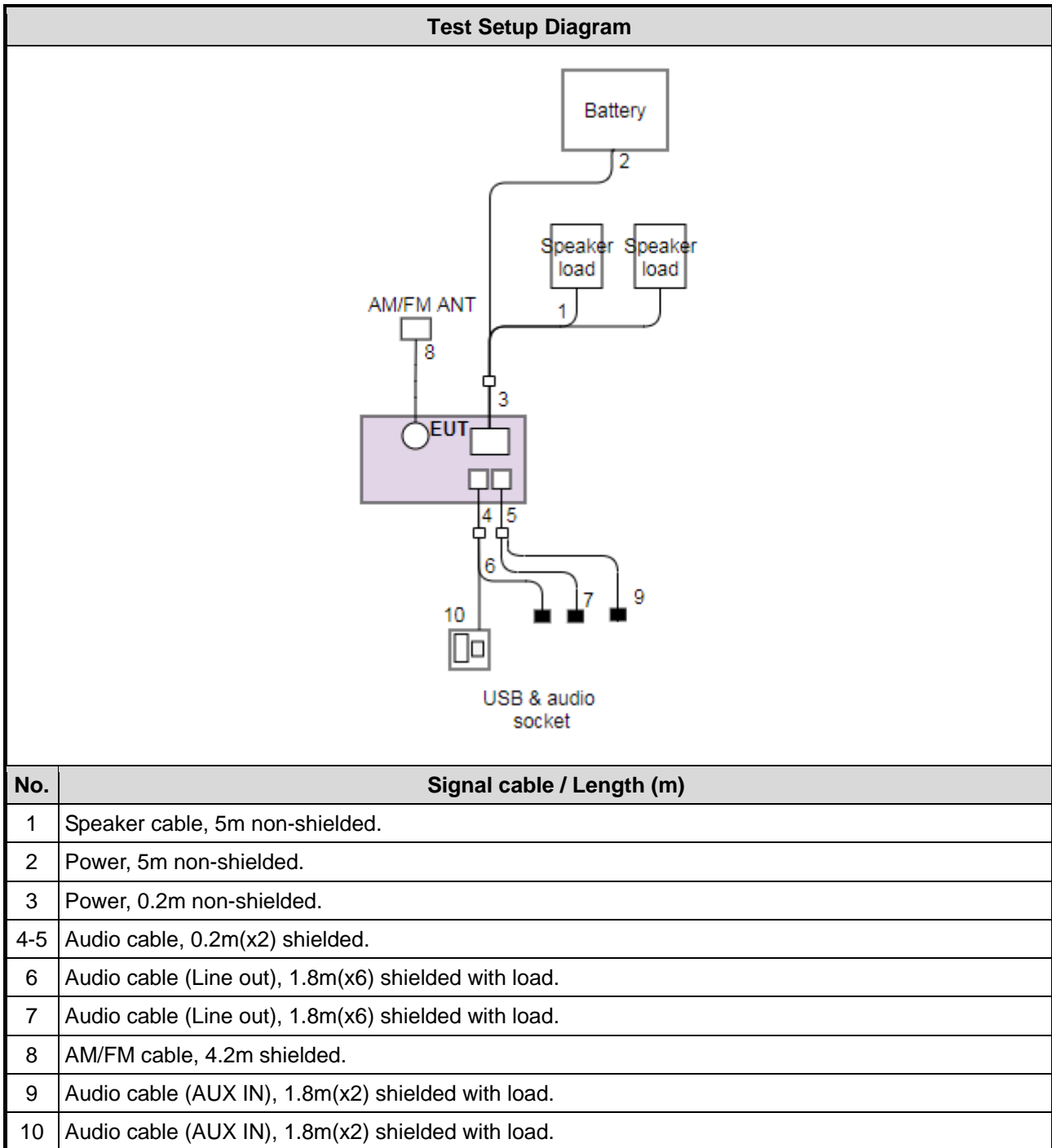

Note: AM/FM ANT and USB dongle & audio load are placed on testing table. The others are on remote testing area.

1.4 The Equipment List

| Test Item | Radiated Emission | | | | |
|-------------------------|-----------------------------|-----------------------|-------------------------|------------------|-------------------|
| Test Site | 966 chamber 3 / (03CH03-WS) | | | | |
| Tested Date | Nov. 04 ~ Nov. 10, 2020 | | | | |
| Instrument | Brand | Model No. | Serial No. | Calibration Date | Calibration Until |
| Spectrum Analyzer | R&S | FSV40 | 101499 | Jan. 09, 2020 | Jan. 08, 2021 |
| Receiver | R&S | ESR3 | 101657 | Feb. 14, 2020 | Feb. 13, 2021 |
| Bilog Antenna | SCHWARZBECK | VULB9168 | VULB9168-685 | Apr. 29, 2020 | Apr. 28, 2021 |
| Horn Antenna 1G-18G | SCHWARZBECK | BBHA 9120 D | BBHA 9120 D 1206 | Dec. 27, 2019 | Dec. 26, 2020 |
| Horn Antenna 18G-40G | SCHWARZBECK | BBHA 9170 | BBHA 9170517 | Nov. 15, 2019 | Nov. 14, 2020 |
| Loop Antenna | R&S | HFH2-Z2 | 100330 | Nov. 13, 2019 | Nov. 12, 2020 |
| Loop Antenna Cable | KOAX KABEL | 101354-BW | 101354-BW | Oct. 06, 2020 | Oct. 05, 2021 |
| Preamplifier | EMC | EMC02325 | 980187 | Aug. 05, 2020 | Aug. 04, 2021 |
| Preamplifier | Agilent | 83017A | MY39501309 | Sep. 02, 2020 | Sep. 01, 2021 |
| Preamplifier | EMC | EMC184045B | 980192 | Jul. 21, 2020 | Jul. 20, 2021 |
| RF cable-3M | HUBER+SUHNER | SUCOFLEX104 | MY22620/4 | Sep. 26, 2020 | Sep. 25, 2021 |
| RF cable-8M | EMC | EMC104-SM-SM-80 00 | 181107 | Sep. 26, 2020 | Sep. 25, 2021 |
| RF cable-1M | HUBER+SUHNER | SUCOFLEX104 | MY22624/4 | Sep. 26, 2020 | Sep. 25, 2021 |
| LF cable-0.8M | EMC | EMC8D-NM-NM-800 | EMC8D-NM-NM-800 -001 | Sep. 26, 2020 | Sep. 25, 2021 |
| LF cable-3M | EMC | EMC8D-NM-NM-300 0 | 131103 | Sep. 26, 2020 | Sep. 25, 2021 |
| LF cable-13M | EMC | EMC8D-NM-NM-130 00 | 131104 | Sep. 26, 2020 | Sep. 25, 2021 |
| Measurement Software | AUDIX | e3 | 6.120210g | NA | NA |

Note: Calibration Interval of instruments listed above is one year.

1.5 Test Standards

47 CFR FCC Part 15.249
ANSI C63.10-2013

1.6 Deviation from Test Standard and Measurement Procedure

None

1.7 Measurement Uncertainty

The measurement uncertainties given below are based on a 95% confidence level (based on a coverage factor ($k=2$)).

| Measurement Uncertainty | |
|--------------------------------|-----------------|
| Parameters | Uncertainty |
| Bandwidth | ± 34.130 Hz |
| Radiated emission ≤ 1 GHz | ± 3.96 dB |
| Radiated emission > 1 GHz | ± 4.51 dB |

2 Test Configuration

2.1 Testing Facility

| | |
|-----------------------------|--|
| Test Laboratory | International Certification Corporation |
| Test Site | 03CH03-WS |
| Address of Test Site | No.14-1, Lane 19, Wen San 3rd St., Kwei Shan Dist., Tao Yuan City 333, Taiwan (R.O.C.) |

- FCC Designation No.: TW0009
- FCC site registration No.: 207696
- ISED#: 10807A
- CAB identifier: TW2732

2.2 The Worst Test Modes and Channel Details

| Test item | Mode | Test Frequency (MHz) | Data Rate | Test Configuration |
|--------------------------------|------|----------------------|-----------|--------------------|
| Field Strength of Fundamental | GFSK | 2460 | 1 Mbps | --- |
| Radiated Emissions \leq 1GHz | GFSK | 2460 | 1 Mbps | --- |
| Radiated Emissions $>$ 1GHz | GFSK | 2460 | 1 Mbps | --- |
| 20dB bandwidth | GFSK | 2460 | 1 Mbps | --- |

3 Transmitter Test Results

3.1 Radiated Emission

This section includes field strength of fundamental, field strength of harmonics and emissions radiated outside of the operating frequency bands.

3.1.1 Limit of field strength of fundamental and field strength of harmonics

| Fundamental Frequency | Field strength of fundamental (millivolts/meter) | Field strength of harmonics (microvolts/meter) |
|-----------------------|--|--|
| 2400–2483.5 MHz | 50 | 500 |

3.1.2 Limit of Unwanted Emissions

Emissions radiated outside of the specified frequency bands, except for harmonics, shall be attenuated by at least 50 dB below the level of the fundamental or to the general radiated emission limits in below table, whichever is the lesser attenuation.

| Radiated emission limits | | | |
|--------------------------|-----------------------|-------------------------|----------------------|
| Frequency Range (MHz) | Field Strength (uV/m) | Field Strength (dBuV/m) | Measure Distance (m) |
| 0.009~0.490 | 2400/F(kHz) | 48.5 - 13.8 | 300 |
| 0.490~1.705 | 24000/F(kHz) | 33.8 - 23 | 30 |
| 1.705~30.0 | 30 | 29 | 30 |
| 30~88 | 100 | 40 | 3 |
| 88~216 | 150 | 43.5 | 3 |
| 216~960 | 200 | 46 | 3 |
| Above 960 | 500 | 54 | 3 |

Note 1:

Qusai-Peak value is measured for frequency below 1GHz except for 9–90 kHz, 110–490 kHz frequency band. Peak and average value are measured for frequency above 1GHz. The limit on average radio frequency emission is as above table. The limit on peak radio frequency emissions is 20 dB above the maximum permitted average emission limit

Note 2:

Measurements may be performed at a distance other than what is specified provided. When performing measurements at a distance other than that specified, the results shall be extrapolated to the specified distance using an extrapolation factor as below, Frequency at or above 30 MHz: 20 dB/decade Frequency below 30 MHz: 40 dB/decade.

3.1.3 Test Procedures

1. Measurement is made at a semi-anechoic chamber that incorporates a turntable allowing a EUT rotation of 360°. A continuously-rotating, remotely-controlled turntable is installed at the test site to support the EUT and facilitate determination of the direction of maximum radiation for each EUT emission frequency. The EUT is placed at test table. For emissions testing at or below 1 GHz, the table height is 80 cm above the reference ground plane. For emission measurements above 1 GHz, the table height is 1.5 m
2. Measurement is made with the antenna positioned in both the horizontal and vertical planes of polarization. The measurement antenna is varied in height (1m ~ 4m) above the reference ground plane to obtain the maximum signal strength. Distance between EUT and antenna is 3 m.
3. This investigation is performed with the EUT rotated 360°, the antenna height scanned between 1 m and 4 m, and the antenna rotated to repeat the measurements for both the horizontal and vertical antenna polarizations.

Note:

1. Radiated emission below 1GHz
120kHz measurement bandwidth of test receiver and Quasi-peak detector is for radiated emission
2. Radiated emission above 1GHz / Peak value except fundamental
RBW=1MHz, VBW=3MHz and Peak detector
3. Radiated emission above 1GHz / Average value for field strength of fundamental and harmonics
The average value is: Average = Peak value + 20log(Duty cycle) Where the duty factor is calculated from following formula:

$$20\log(\text{Duty cycle}) = 20\log \frac{0.29565 \times 2\text{ms}}{100 \text{ms}} = -44.56\text{dB}$$

Please see page 18 for plotted duty

4. Radiated emission above 1GHz / Average value for other emissions
RBW=1MHz, VBW=1Hz and Peak detector
5. Radiated emission Peak value for fundamental
RBW=1MHz, VBW=3MHz and Peak detector

3.1.4 Test Setup

Radiated Emissions below 1 GHz

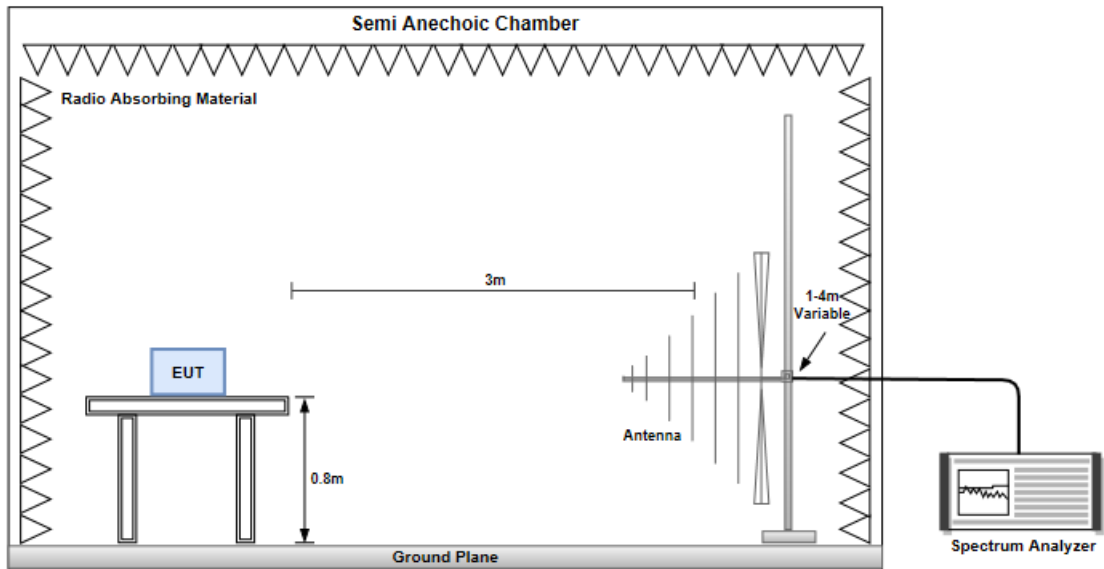

Radiated Emissions above 1 GHz

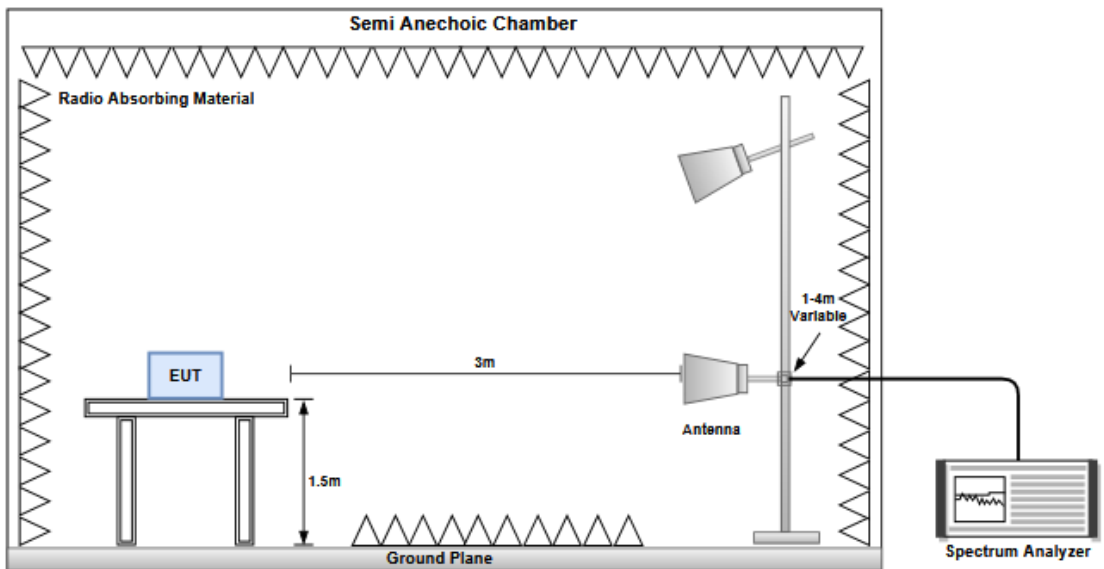

3.1.5 Transmitter Radiated Unwanted Emissions (Below 1GHz)

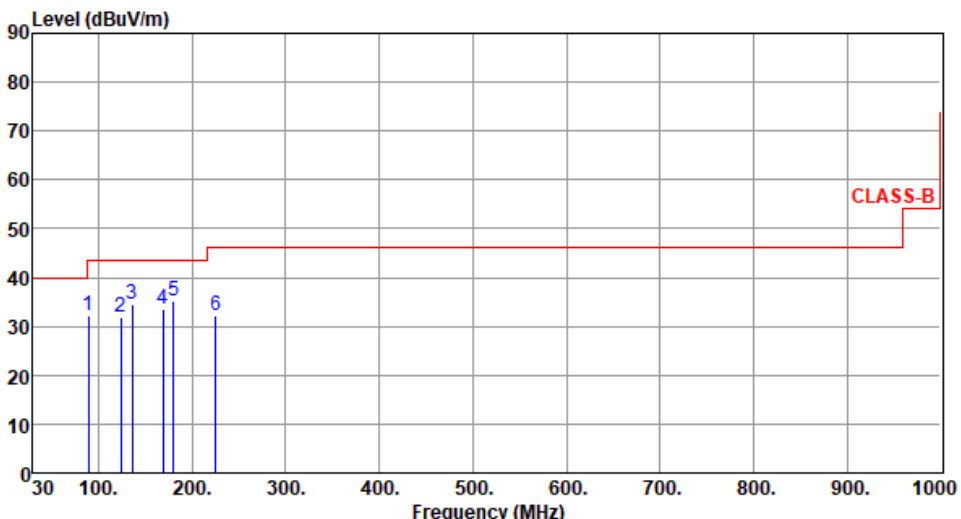
| | | | | | | | | | |
|--|------------|-------------------------|--------------|-----------|-----------------|-----------|--------|-------------|----------------|
| Modulation | GFSK | Test Freq. (MHz) | 2460 | | | | | | |
| Polarization | Horizontal | | | | | | | | |
| Test By : Akun Chung Temperature(°C): 23 Humidity(%): 67 | | | | | | | | | |
|  | | | | | | | | | |
| | Freq. MHz | Emission level dBuV/m | Limit dBuV/m | Margin dB | SA reading dBuV | Factor dB | Remark | ANT High cm | Turn Table deg |
| 1 | 89.17 | 32.21 | 43.50 | -11.29 | 47.06 | -14.85 | Peak | --- | --- |
| 2 | 124.09 | 31.97 | 43.50 | -11.53 | 42.78 | -10.81 | Peak | --- | --- |
| 3 | 135.73 | 34.64 | 43.50 | -8.86 | 44.16 | -9.52 | Peak | --- | --- |
| 4 | 168.71 | 33.48 | 43.50 | -10.02 | 42.65 | -9.17 | Peak | --- | --- |
| 5 | 180.35 | 35.21 | 43.50 | -8.29 | 45.68 | -10.47 | Peak | --- | --- |
| 6 | 224.97 | 32.18 | 46.00 | -13.82 | 44.63 | -12.45 | Peak | --- | --- |
| <p>Note 1: Emission Level (dBuV/m) = SA Reading (dBuV/m) + Factor* (dB) *Factor includes antenna factor , cable loss and amplifier gain Note 2: Margin (dB) = Emission level (dBuV/m) – Limit (dBuV/m). Note 3: All spurious emissions below 30MHz are more than 20 dB below the limit.</p> | | | | | | | | | |

| | | | |
|---------------------|----------|-------------------------|------|
| Modulation | GFSK | Test Freq. (MHz) | 2460 |
| Polarization | Vertical | | |

Test By : Akun Chung Temperature(°C): 23 Humidity(%): 67

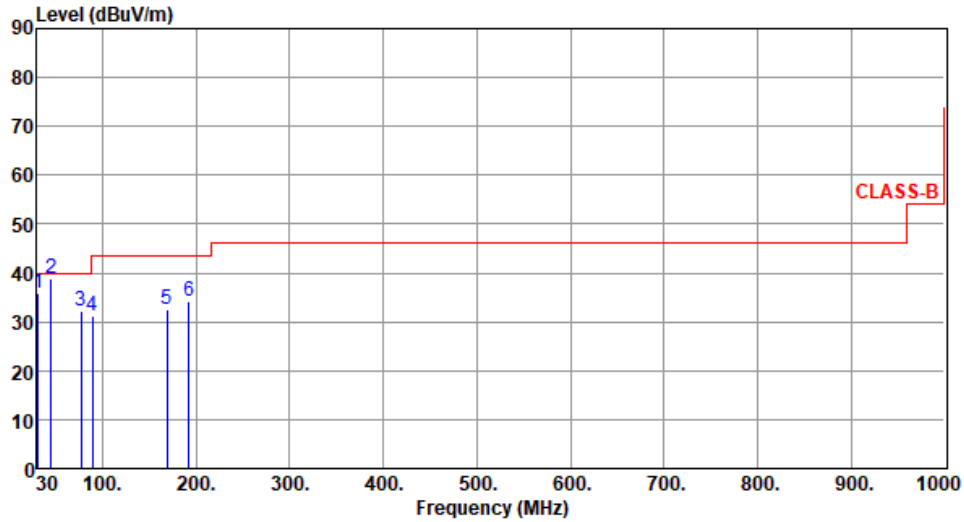

| | Freq. MHz | Emission level dBuV/m | Limit dBuV/m | Margin dB | SA reading dBuV | Factor dB | Remark | ANT High cm | Turn Table deg |
|---|--------------|-----------------------------|-----------------|--------------|-----------------------|--------------|--------|-------------------|----------------------|
| 1 | 30.97 | 35.96 | 40.00 | -4.04 | 46.04 | -10.08 | Peak | --- | --- |
| 2 | 45.17 | 38.98 | 40.00 | -1.02 | 47.80 | -8.82 | QP | 100 | 262 |
| 3 | 77.53 | 32.17 | 40.00 | -7.83 | 45.07 | -12.90 | Peak | --- | --- |
| 4 | 89.17 | 31.11 | 43.50 | -12.39 | 45.96 | -14.85 | Peak | --- | --- |
| 5 | 168.71 | 32.51 | 43.50 | -10.99 | 41.68 | -9.17 | Peak | --- | --- |
| 6 | 191.99 | 34.32 | 43.50 | -9.18 | 46.25 | -11.93 | Peak | --- | --- |

Note 1: Emission Level (dBuV/m) = SA Reading (dBuV/m) + Factor* (dB)

*Factor includes antenna factor , cable loss and amplifier gain

Note 2: Margin (dB) = Emission level (dBuV/m) – Limit (dBuV/m).

Note 3: All spurious emissions below 30MHz are more than 20 dB below the limit.

3.1.6 Transmitter Radiated Unwanted Emissions (Above 1GHz)

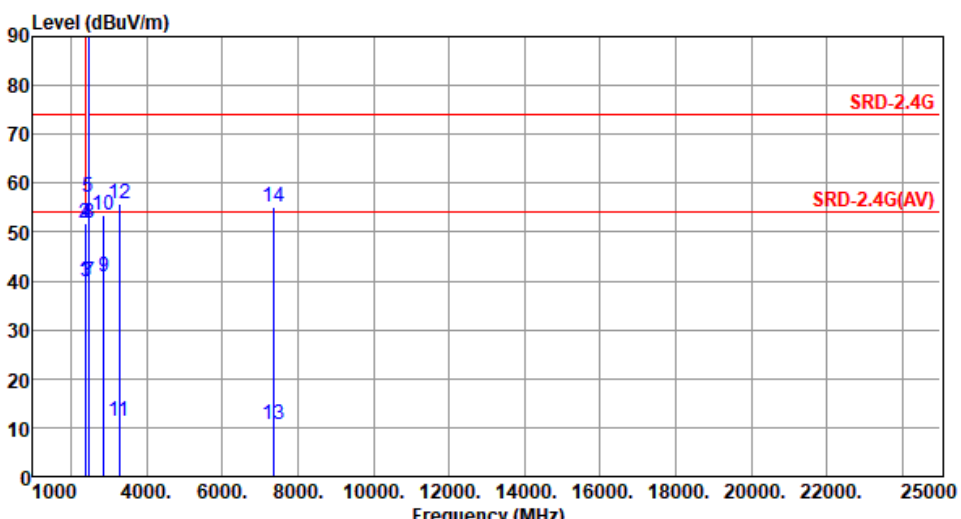
| Modulation | GFSK | Test Freq. (MHz) | 2460 | | | | | | |
|---|------------|-----------------------|--------------|-----------|-----------------|-----------|---------|-------------|----------------|
| Polarization | Horizontal | | | | | | | | |
| Test By : Akun Chung Temperature(°C): 23 Humidity(%): 67 | | | | | | | | | |
|  | | | | | | | | | |
| | Freq. MHz | Emission level dBuV/m | Limit dBuV/m | Margin dB | SA reading dBuV | Factor dB | Remark | ANT High cm | Turn Table deg |
| 1 | 2390.00 | 39.69 | 54.00 | -14.31 | 41.53 | -1.84 | Average | 384 | 233 |
| 2 | 2390.00 | 51.88 | 74.00 | -22.12 | 53.72 | -1.84 | Peak | 384 | 233 |
| 3 | 2400.00 | 39.77 | 54.00 | -14.23 | 41.65 | -1.88 | Average | 384 | 233 |
| 4 | 2400.00 | 51.91 | 74.00 | -22.09 | 53.79 | -1.88 | Peak | 384 | 233 |
| 5 | 2460.00 | 57.01 | 94.00 | -36.99 | 58.80 | -1.79 | Average | 384 | 233 |
| 6 | 2460.00 | 101.57 | 114.00 | -12.43 | 103.36 | -1.79 | Peak | 384 | 233 |
| 7 | 2483.50 | 39.70 | 54.00 | -14.30 | 41.50 | -1.80 | Average | 384 | 233 |
| 8 | 2483.50 | 51.69 | 74.00 | -22.31 | 53.49 | -1.80 | Peak | 384 | 233 |
| 9 | 2870.00 | 40.86 | 54.00 | -13.14 | 41.15 | -0.29 | Average | 384 | 206 |
| 10 | 2870.00 | 53.38 | 74.00 | -20.62 | 53.67 | -0.29 | Peak | 384 | 206 |
| 11 | 3280.00 | 11.30 | 54.00 | -42.70 | 10.85 | 0.45 | Average | 110 | 219 |
| 12 | 3280.00 | 55.86 | 74.00 | -18.14 | 55.41 | 0.45 | Peak | 110 | 219 |
| 13 | 7380.00 | 10.73 | 54.00 | -43.27 | 0.45 | 10.28 | Average | 233 | 124 |
| 14 | 7380.00 | 55.29 | 74.00 | -18.71 | 45.01 | 10.28 | Peak | 233 | 124 |

Note 1: Emission Level (dBuV/m) = SA Reading (dBuV/m) + Factor* (dB)
*Factor includes antenna factor , cable loss and amplifier gain
Note 2: Margin (dB) = Emission level (dBuV/m) – Limit (dBuV/m).

| | | | |
|---------------------|----------|-------------------------|------|
| Modulation | GFSK | Test Freq. (MHz) | 2460 |
| Polarization | Vertical | | |

Test By : Akun Chung Temperature(°C): 23 Humidity(%): 67

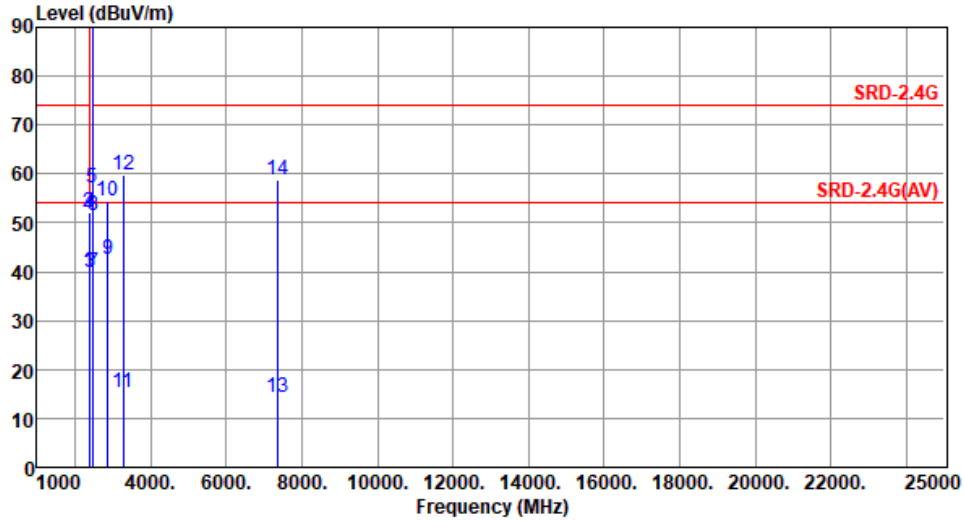

| | Freq. MHz | Emission level dBuV/m | Limit dBuV/m | Margin dB | SA reading dBuV | Factor dB | Remark | ANT High cm | Turn Table deg |
|----|--------------|-----------------------------|-----------------|--------------|-----------------------|--------------|---------|-------------------|----------------------|
| 1 | 2390.00 | 39.93 | 54.00 | -14.07 | 41.77 | -1.84 | Average | 112 | 357 |
| 2 | 2390.00 | 52.14 | 74.00 | -21.86 | 53.98 | -1.84 | Peak | 112 | 357 |
| 3 | 2400.00 | 39.90 | 54.00 | -14.10 | 41.78 | -1.88 | Average | 112 | 357 |
| 4 | 2400.00 | 52.13 | 74.00 | -21.87 | 54.01 | -1.88 | Peak | 112 | 357 |
| 5 | 2460.00 | 57.27 | 94.00 | -36.73 | 59.06 | -1.79 | Average | 112 | 357 |
| 6 | 2460.00 | 101.83 | 114.00 | -12.17 | 103.62 | -1.79 | Peak | 112 | 357 |
| 7 | 2483.50 | 39.73 | 54.00 | -14.27 | 41.53 | -1.80 | Average | 112 | 357 |
| 8 | 2483.50 | 51.55 | 74.00 | -22.45 | 53.35 | -1.80 | Peak | 112 | 357 |
| 9 | 2870.00 | 42.42 | 54.00 | -11.58 | 42.71 | -0.29 | Average | 112 | 357 |
| 10 | 2870.00 | 54.38 | 74.00 | -19.62 | 54.67 | -0.29 | Peak | 112 | 357 |
| 11 | 3280.00 | 15.16 | 54.00 | -38.84 | 14.71 | 0.45 | Average | 297 | 334 |
| 12 | 3280.00 | 59.72 | 74.00 | -14.28 | 59.27 | 0.45 | Peak | 297 | 334 |
| 13 | 7380.00 | 14.23 | 54.00 | -39.77 | 3.95 | 10.28 | Average | 229 | 277 |
| 14 | 7380.00 | 58.79 | 74.00 | -15.21 | 48.51 | 10.28 | Peak | 229 | 277 |

Note 1: Emission Level (dBuV/m) = SA Reading (dBuV/m) + Factor* (dB)

*Factor includes antenna factor , cable loss and amplifier gain

Note 2: Margin (dB) = Emission level (dBuV/m) – Limit (dBuV/m).

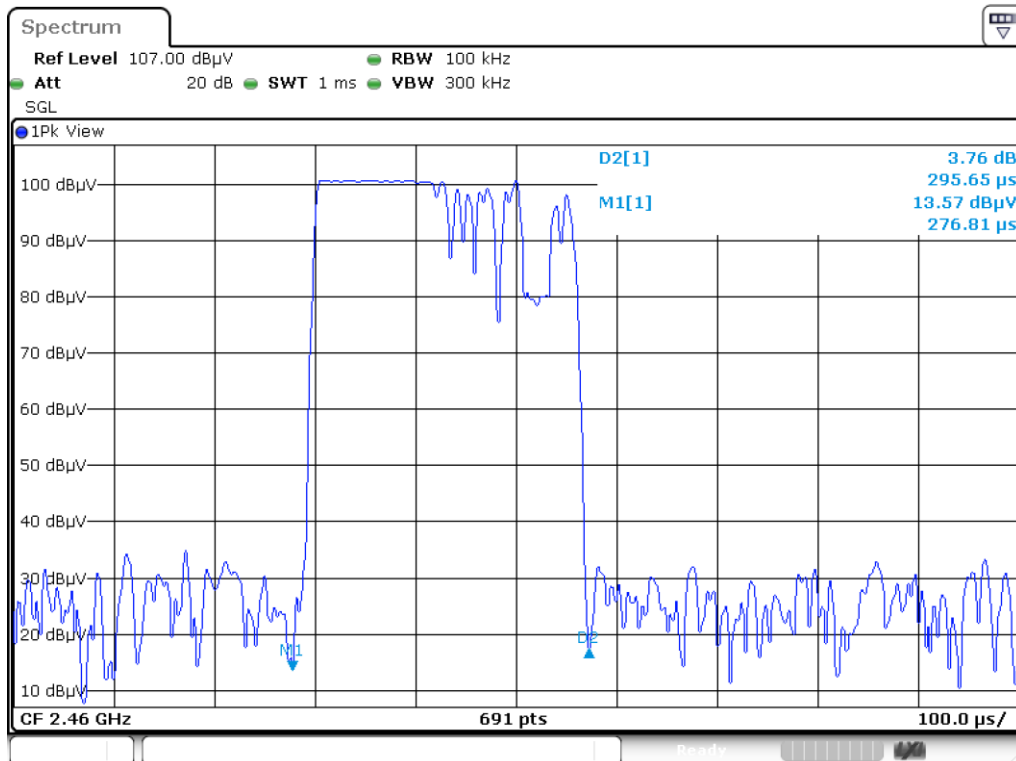
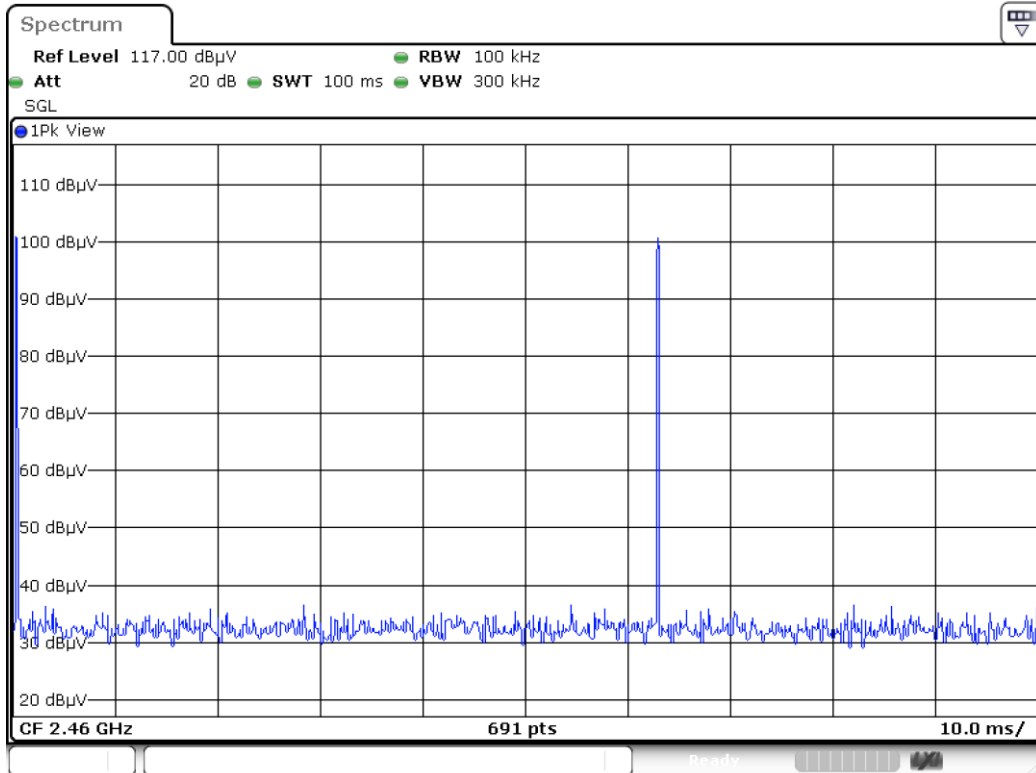

$$20\log(\text{Duty cycle}) = 20\log \frac{0.29565 \times 2 \text{ ms}}{100 \text{ ms}} = -44.56\text{dB}$$

3.2 20dB and Occupied Bandwidth

3.2.1 Test Procedures

1. Set resolution bandwidth (RBW) = 30 kHz, Video bandwidth = 100 kHz.
2. Detector = Peak(20 dB bandwidth) / Sample(Occupied bandwidth), Trace mode = max hold
3. Sweep = auto couple, Allow the trace to stabilize.
4. Measure the maximum width of the emission that is constrained by the frequencies associated with the two outermost amplitude points (upper and lower) that are attenuated by 20dB relative to the maximum level measured in the fundamental emission.
5. Use the occupied measurement function of spectrum analyzer to measure 99% occupied bandwidth.

3.2.2 Test Setup

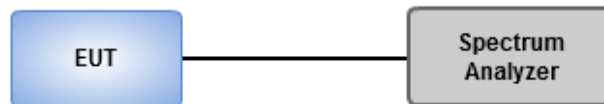

3.2.3 20dB and Occupied Bandwidth

| | | | |
|-------------------|------------|-----------|------------|
| Ambient Condition | 23°C / 67% | Tested By | Akun Chung |
|-------------------|------------|-----------|------------|

| Freq. (MHz) | 20dB Bandwidth (MHz) | Occupied Bandwidth (MHz) |
|-------------|----------------------|--------------------------|
| 2460 | 0.905 | 0.847 |

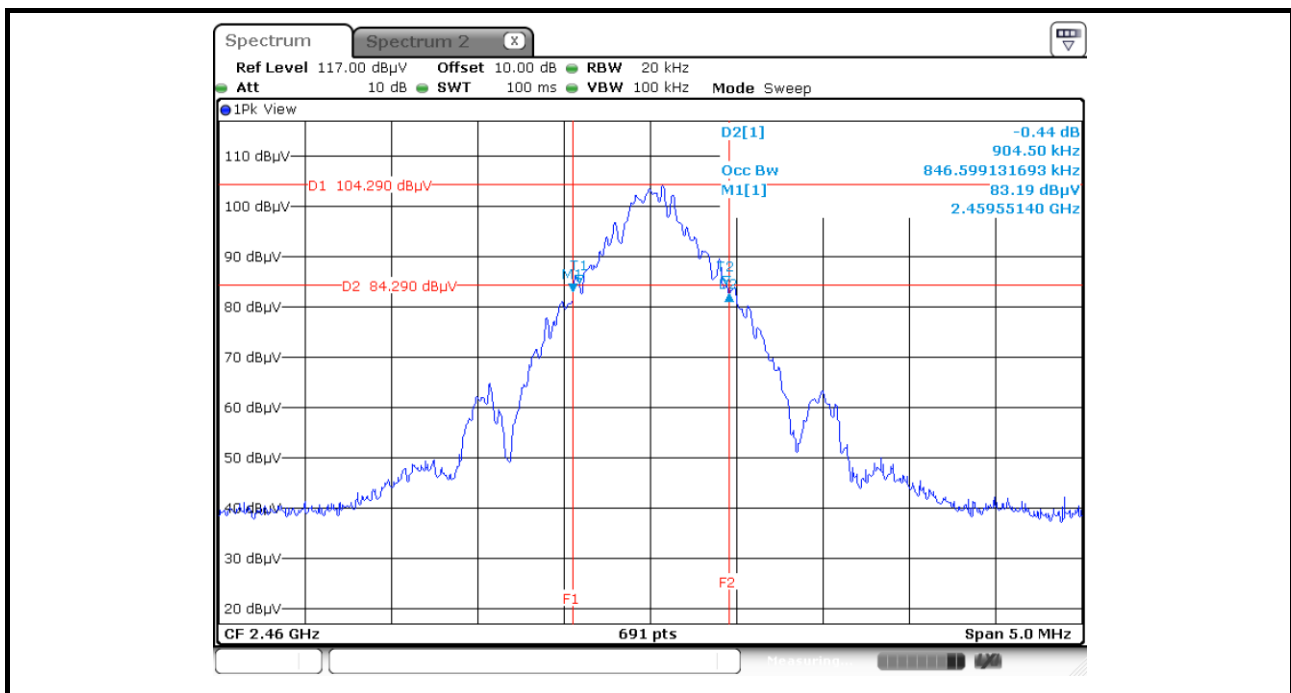

4 Test laboratory information

Established in 2012, ICC provides foremost EMC & RF Testing and advisory consultation services by our skilled engineers and technicians. Our services employ a wide variety of advanced edge test equipment and one of the widest certification extents in the business.

International Certification Corporation (EMC and Wireless Communication Laboratory), it is our definitive objective is to institute long term, trust-based associations with our clients. The expectation we set up with our clients is based on outstanding service, practical expertise and devotion to a certified value structure. Our passion is to grant our clients with best EMC / RF services by oriented knowledgeable and accommodating staff.

Our Test sites are located at Linkou District and Kwei Shan District. Location map can be found on our website <http://www.icertifi.com.tw>.

Linkou

Tel: 886-2-2601-1640

No.30-2, Ding Fwu Tsuen, Lin Kou
District, New Taipei City, Taiwan
(R.O.C.)

Kwei Shan

Tel: 886-3-271-8666

No.3-1, Lane 6, Wen San 3rd
St., Kwei Shan Dist., Tao Yuan
City 33381, Taiwan (R.O.C.)

Kwei Shan Site II

Tel: 886-3-271-8640

No.14-1, Lane 19, Wen San 3rd
St., Kwei Shan Dist., Tao Yuan
City 333, Taiwan (R.O.C.)

If you have any suggestion, please feel free to contact us as below information.

Tel: 886-3-271-8666

Fax: 886-3-318-0155

Email: ICC_Service@icertifi.com.tw

==END==