

DRAFT

GARMIN®

GMR FANTOM™ OPEN ARRAY SERIES

INSTALLATION INSTRUCTIONS

Important Safety Information

⚠ WARNING

See the *Important Safety and Product Information* guide in the product box for product warnings and other important information.

The radar transmits electromagnetic energy. Ensure that the radar is installed according to the recommendations in these instructions and that all personnel are clear of the path of the radar beam before transmitting. When properly installed and operated, the use of this radar conforms to the requirements of ANSI/IEEE C95.1-1992 Standard for Safety Levels with Respect to Human Exposure to Radio Frequency Electromagnetic Fields.

When the radar is transmitting, do not look directly at the antenna at close range; eyes are the most sensitive part of the body to electromagnetic energy.

When connecting the power cable, do not remove the in-line fuse holder. To prevent the possibility of injury or product damage caused by fire or overheating, the appropriate fuse must be in place as indicated in the product specifications. In addition, connecting the power cable without the appropriate fuse in place voids the product warranty.

⚠ CAUTION

This device should be used only as a navigational aid. Do not attempt to use the device for any purpose requiring precise measurement of direction, distance, location, or topography.

Always wear safety goggles, ear protection, and a dust mask when drilling, cutting, or sanding.

Opening the device may result in personal injury and/or damage to the device. This device contains no user-serviceable parts, and should be opened only by a Garmin® authorized service technician. Any damage resulting from opening the unit by anyone other than a Garmin authorized service technician will not be covered by the Garmin warranty.

NOTICE

When drilling or cutting, always check what is on the opposite side of the surface.

Tools Needed

- #2 Phillips screwdriver
- 5 mm hex wrench
- Drill
- 15 mm ($19/32$ in.) drill bit
- 32 mm ($1\ 1/4$ in.) drill bit (optional)
- 17 mm ($21/32$ in.) wrench and torque wrench
- 3.31 mm² (12 AWG) copper wire to ground the radar housing and voltage converter, if applicable (the length depends on the distance from the radar to ground)
- Marine sealant

Mounting Considerations

When selecting a mounting location, observe these considerations.

- It is highly recommended that the device is mounted out of range of people, with the vertical beam width above head height. To avoid exposure to harmful radio frequency (RF) levels, the device should not be mounted

closer to people than the maximum safe distance value listed in the product specifications.

- The device should be mounted high above the ship's keel line with minimal blockage of the radar beam. Obstructions may cause blind and shadow sectors or generate false echoes. The higher the installation position, the farther the radar can detect targets.
- The device should be mounted on a flat surface or a platform that is parallel to the vessel's water line and is sturdy enough to support the device's weight. The weight for each model and antenna is listed in the product specifications.
- The device must be mounted in a location where it can be connected to power, water ground, and the Garmin Marine Network (*Wiring and Connection Considerations*, page 2).
- The radar beam spreads vertically 11.5° above and 11.5° below ① the radar's radiating element. On vessels with higher bow angles at cruise speed, the installation angle can be lowered to point the beam slightly downward to the waterline while at rest. Shims can be used if necessary.

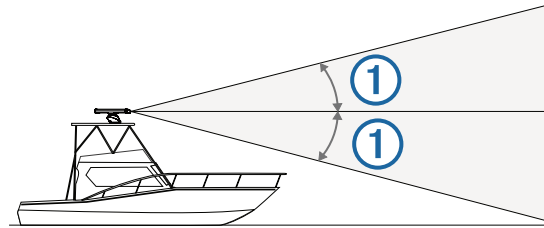

- The device should be mounted away from heat sources, such as smoke stacks and lights.
- The device should be mounted at a different level than horizontal spreaders and mast crossrees.
- To avoid interference with a magnetic compass, the device should not be mounted closer to a compass than the compass-safe distance value listed in the product specifications.
- Other electronics and cables should be mounted more than 2 m (6.5 ft.) from the radar beam path.
- GPS antennas should be either above or below the radar beam path.
- The device should be mounted at least 1 m (40 in.) from any transmitting equipment.
- The device should be mounted at least 1 m (40 in.) away from cables carrying radio signals such as VHF radios, cables, and antennas.
- The device should be mounted at least 2 m (6.5 ft.) away from Single Side Band (SSB) radios.

Installation Procedures

Preparing the Radar Mounting Surface

Before you can mount the radar, you must choose a suitable mounting location (*Mounting Considerations*, page 1).

- 1 Secure the included mounting template to the surface at the mounting location, along the bow-stern axis, as indicated on the template.
- 2 Drill the mounting holes using a 15 mm ($19/32$ in.) drill bit.
- 3 If you need to run the power and network cables through the mounting surface, select a location along the center channel indicated on the template, drill a pass-through hole for the cables using a 32 mm ($1\ 1/4$ in.) drill bit, and route the cables through the surface (optional) (*Wiring and Connection Considerations*, page 2).
- 4 Remove the mounting template from the surface.

Mounting the Radar

Before you can mount the radar, you must select a mounting location (*Mounting Considerations*, page 1) and prepare the mounting surface (*Preparing the Radar Mounting Surface*, page 1).

EAC CE

Printed in Taiwan
April 2020
RC



DRAFT

- 1 Place the radar onto the mounting surface, aligning the holes on the base of the radar with the holes you drilled when preparing the mounting surface.
- 2 Apply the included Petrolatum Primer to the threads of the four threaded rods.
- 3 Insert the threaded rods ① through the mounting surface and into the radar base, and tighten them using a 5 mm hex wrench.

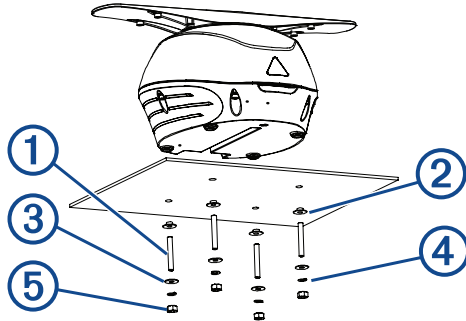

To avoid damaging the pedestal, you should stop tightening the threaded rods when they no longer turn easily.

- 4 From under the mounting surface, place the included plastic shoulder washers ② over the threaded rods and into the holes.
- 5 Place the flat washers ③, lock washers ④, and hex nuts ⑤ on the threaded rods.
- 6 Tighten the hex nuts to a torque of 11 lbf-ft. (14.7 N-m) to securely fasten the radar to the surface without damaging the radar or the mounting hardware.

Installing the Antenna

Before you can install the antenna on the radar, you must securely mount the pedestal (*Mounting the Radar*, page 1).

- 1 Remove the protective cover ① from the waveguide on the top of the pedestal.

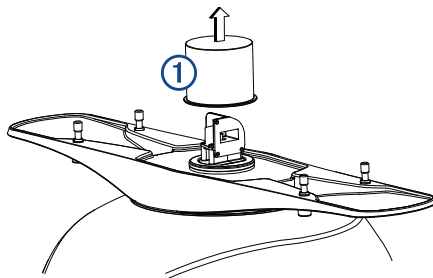

- 2 Align the waveguide on the pedestal ② with the socket on the bottom of the antenna ③, and slide the antenna onto the pedestal.

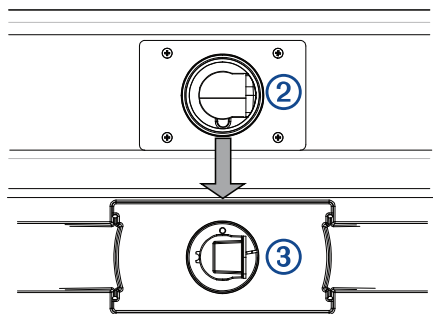

- 3 Secure the antenna to the pedestal by tightening the captive hex bolts under the antenna arm.
- 4 Tighten the hex bolts to a torque of 6 lbf-ft. (7.9 N-m) to fasten the antenna to the pedestal without damaging the antenna or the mounting hardware.

Wiring and Connection Considerations

It may be necessary to drill 32 mm (1¹/₄ in.) holes for routing the power, network, or grounding cables.

- When routing multiple cables through the same hole, you must route the network cable before the power and ground cables because of the size of the network connector.
- You must apply marine sealant to the hole after the cables are in place to ensure a waterproof seal.

If you must make the routing hole in a visible location, decorative cable grommets can be purchased from Garmin or a Garmin dealer (optional).

- If needed, you can trim the grommet to enable you to route multiple cables through the same hole.
- The optional grommet does NOT provide a waterproof seal. You must apply marine sealant to the grommet after the cables are in place to ensure a waterproof seal.

When installing the cables, you should observe these considerations.

- Cutting the Garmin Marine Network cable is not recommended, but a field install kit can be purchased from Garmin or a Garmin dealer if you must cut the network cable.
- The ground cable is not included, and must connect to a water ground location, not the negative terminal of the battery (*Grounding the Radar*, page 3).
- To ensure safety, appropriate tie-wraps, fasteners, and sealant should be used to secure the cable along the route and through any bulkheads or the deck.
- You should not run cables near moving objects and high-heat sources, or through doorways and bilges.
- To avoid interference with other equipment, you should not run network and power cables parallel to other cables, such as radio antenna lines or power cables. If this is not possible, the cables should be shielded with metal conduit or a form of EMI shielding.
- You should install the power cable as close to the battery source as possible.
 - If it is necessary to extend the power cable, you must use the appropriate wire gauge (*Power Cable Extensions*, page 3).
 - Incorrectly extended runs of cable may cause the radar to malfunction due to insufficient power transmission.

Connecting to Power Through the Voltage Converter

⚠ WARNING

When connecting the power cable, do not remove the in-line fuse holder. To prevent the possibility of injury or product damage caused by fire or overheating, the appropriate fuse must be in place as indicated in the product specifications. In addition, connecting the power cable without the appropriate fuse in place voids the product warranty.

NOTICE

Do not reuse any voltage converters from previous Garmin radar models, or third party voltage converters. Using any converter other than one included with the radar may damage the radar or prevent it from turning on.

Some radar models require a voltage converter unit to properly power the device. If your model is packaged with a voltage converter, it must be installed in order for your radar to function. If your model is not packaged with a voltage converter, connect the power cable directly to the boat battery (*Connecting to Power*, page 3).

When installing the voltage converter for an applicable radar model, observe these considerations.

- The voltage converter requires an input voltage of 10 to 32 Vdc.
- It is recommended to install the voltage converter as close as possible to the power source.
- Connecting the power cable for the voltage converter directly to the battery is recommended. If it is necessary to extend the cable, the appropriate gauge of wire must be used for the length of the extension (*Power Cable Extensions*, page 3).

DRAFT

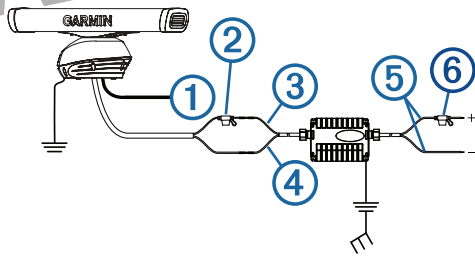

Item	Description
①	To the Garmin Marine Network
②	15 A fuse holder
③	Red (+)
④	Black (-)
⑤	To the boat battery (10 to 32 Vdc)
⑥	30 A fuse holder
⊥	Water ground connection

- Route the power cable to the radar and the voltage converter.
- Use crimp connectors and heat-shrink tubing to connect the power cable to the voltage converter.
The radar power cable contains a 15 A fuse which should not be removed when connecting to the voltage converter.
- Connect the voltage converter to the boat battery through the included 30 A fuse.
The 30 A fuse between the voltage converter and battery is in addition to the 15 A fuse included in the radar power cable. Both fuses must be in place for the radar to function properly.
- Connect the power cable to the POWER port on the radar.

Connecting to Power

⚠ WARNING

When connecting the power cable, do not remove the in-line fuse holder. To prevent the possibility of injury or product damage caused by fire or overheating, the appropriate fuse must be in place as indicated in the product specifications. In addition, connecting the power cable without the appropriate fuse in place voids the product warranty.

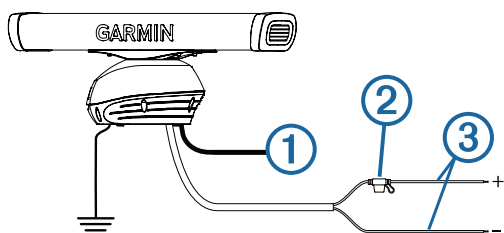

Item	Description
①	To the Garmin Marine Network
②	15 A fuse holder
③	To the boat battery (from 10 to 32 Vdc)
⊥	Water ground connection

- Route the power cable to the radar and boat battery.
- Connect the power cable to the boat battery.
- Connect the power cable to the POWER port on the radar.

Power Cable Extensions

Connecting the power cable directly to the battery is recommended. If it is necessary to extend the cable, the appropriate gauge of wire must be used for the length of the extension.

You must use crimp connectors and heat-shrink to create a water-resistant connection.

Distance	Wire Gauge
3 m (9 ft. 10 in.)	3.31 mm ² (12 AWG)
5 m (16 ft. 4 in.)	5.26 mm ² (10 AWG)
6.5 m (21 ft. 3 in.)	6.63 mm ² (9 AWG)
8 m (26 ft. 2 in.)	8.36 mm ² (8 AWG)

Grounding the Radar

The radar must be connected to the appropriate type of ground using 3.31 mm² (12 AWG) copper wire (not included).

- Route a 3.31 mm² (12 AWG) copper wire to a water ground location and to the radar pedestal.
- Connect the wire to the ground connector (⊥) on the pedestal using the pre-installed crimp connector ①.

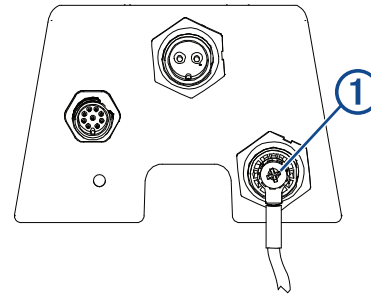

- Coat the ground screw and crimp connector with marine sealant.
- Connect the other end of the wire to the water ground location on the boat, and coat the connection with marine sealant.
- Select an option:
 - If your radar was not packaged with a voltage converter, no further grounding is necessary.
 - If your radar was packaged with a voltage converter, proceed to the next step.
- Route a different 3.31 mm² (12 AWG) copper wire to water ground location and to the voltage converter.
- Loosen a screw on one corner of the voltage converter, and secure the copper wire to the screw.
- Coat the screw and wire on the voltage converter with marine sealant.
- Connect the other end of the wire to the water ground location on the boat, and coat the connection with marine sealant.

Garmin Marine Network Considerations

This device connects to Garmin Marine Network devices to share radar data with compatible devices on the network. When connecting to a Garmin Marine Network device, observe these considerations.

- A Garmin Marine Network cable must be used for all Garmin Marine Network connections.
 - You cannot cut a Garmin Marine Network cable. You must use a longer cable or add extensions where necessary.
 - Garmin Marine Network cables and extension cables are available from your Garmin dealer.
- If necessary, you may need to use a Garmin Marine Network adapter cable to connect this device to your chartplotter or GMS™ 10 network port expander.

Connecting a Garmin Marine Network Cable

- Route one end of the Garmin Marine Network cable to the radar.

NOTE: The included Garmin Marine Network cable uses a 90-degree connector to connect to the NETWORK port on the radar housing so that it fits correctly behind the radar door. If you do not plan to install the door on the radar housing, you can purchase a Garmin Marine Network cable with a straight connector from your Garmin dealer.

- Connect the cable to the NETWORK port on the radar.

NOTICE

Use caution when connecting the cable to the radar. If you attempt to connect the cable at an angle, you may damage the pins on the NETWORK port.

- Turn the ring on the cable clockwise to secure the cable to the radar.

Installing a Garmin Marine Network Adapter Cable

If necessary, you can use the included Garmin Marine Network adapter cable to connect this device to your chartplotter or GMS 10 network port expander.

- Connect the Garmin Marine Network cable to the device, and route it to your chartplotter or port expander.
- If it is not already pre-installed, connect the included adapter to the end of the Garmin Marine Network cable.
- Connect the adapter cable to your chartplotter or port expander.

Installing the Cable Cover

You must mount the radar, route all cables, and connect them to the radar before you can install the cable cover.

- Hold the cable cover ① parallel to the side of the pedestal ②.

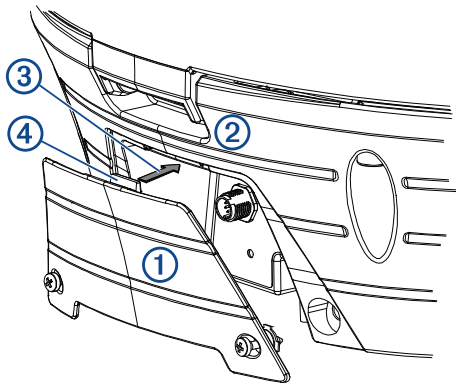

- Slide the cable cover onto the pedestal ③, and slide the tab ④ into the slot on the pedestal.
- Secure the cable cover to the pedestal using the attached screws.

Radar Operation

All functions of this radar are controlled with your Garmin chartplotter. See the Radar section of your chartplotter's owner's manual for operating instructions. To download the latest manual, go to www.garmin.com/manuals.

If you have more than one radar on your boat, you must be viewing the radar screen for the radar you want to configure.

Software Update

You must update the Garmin chartplotter software when you install this device.

If your chartplotter has Wi-Fi[®] technology, you should update the software using the ActiveCaptain[®] app on a compatible Android[™] or Apple[®] device.

If your chartplotter does not have Wi-Fi technology, you should update the software using a memory card and a Windows[®] or Mac[®] computer.

For more information, go to support.garmin.com.

Specifying the Antenna Size

Before you can use the radar on your system, you must specify the antenna size.

- Turn on the radar and all devices connected to the Garmin Marine Network.
An antenna-selection prompt appears on the connected chartplotters.
NOTE: If the entire system is being turned on for the first time, the antenna-selection screen is part of the initial setup process.
- Select the installed antenna size for each open-array radar installed on the boat.

TIP: If you need to specify a different antenna size, while viewing the radar screen for the radar you want to change, select **Menu > Radar Setup >**

Installation > Antenna Configuration > Antenna Size, and select the antenna size.

Front-of-Boat Offset

The front-of-boat offset compensates for the physical location of the radar scanner on a boat, if the radar scanner does not align with the bow-stern axis.

Measuring the Potential Front-of-Boat Offset

The front-of-boat offset compensates for the physical location of the radar scanner on a boat, if the radar scanner does not align with the bow-stern axis.

- Using a magnetic compass, take an optical bearing of a stationary target located within viewable range.
- Measure the target bearing on the radar.
- If the bearing deviation is more than $\pm 1^\circ$, set the front-of-boat offset.

Setting the Front-of-Boat Offset

Before you can set the front-of-boat offset, you must measure the potential front-of-boat offset.

The front-of-boat offset setting configured for use in one radar mode is applied to every other radar mode and to the Radar overlay.

- From a Radar screen or the Radar overlay, select **Menu > Radar Setup > Installation > Front of Boat**.
- Select **Up** or **Down** to adjust the offset.

Setting a Custom Park Position

By default, the antenna is stopped perpendicular to the pedestal when it is not spinning. You can adjust this position.

- From the radar screen, select **Menu > Radar Setup > Installation > Antenna Configuration > Park Position**.
- Use the slider bar to adjust the position of the antenna when stopped, and select **Back**.

Specifications

Dimensions

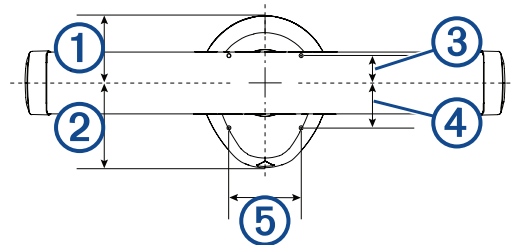

Item	Measurement	Description
①	185.9 mm (7 ⁵ / ₁₆ in.)	Center of rotation to the rear of the pedestal
②	234.7 mm (9 ¹ / ₄ in.)	Center of rotation to the front of the pedestal
③	86 mm (3 ²⁵ / ₆₄ in.)	Center of rotation to the rear mounting holes
④	114 mm (4 ¹ / ₂ in.)	Center of rotation to the front mounting holes
⑤	200 mm (7 ⁷ / ₈ in.)	Distance between the mounting holes

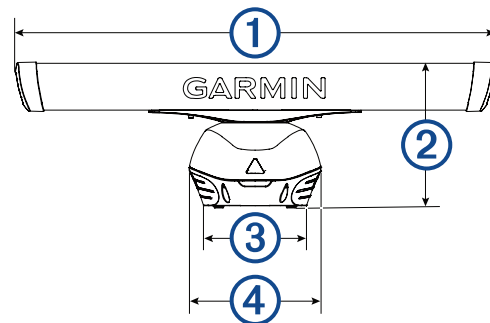

DRAFT

Item	Measurement	Description
①	4 ft. models: 132.8 cm (4 ft. 4 ⁵ / ₁₆ in.) 6 ft. models: 193.8 cm (6 ft. 4 ⁵ / ₁₆ in.)	Antenna length
②	40.3 cm (15 ⁷ / ₈ in.)	Base of the pedestal to the top of the antenna
③	28.6 cm (11 ¹ / ₄ in.)	Width of the pedestal at the base
④	36.4 cm (14 ⁵ / ₁₆ in.)	Width of the pedestal in the center

Physical Specifications

Specification	Measurement
Minimum safe operating distance ¹	
Compass-safe distance	300 mm (11.8 in.)
Pedestal weight	15.8 kg (34.8 lb.)
Antenna weight	4 ft. antenna: 5.2 kg (11.4 lb.) 6 ft. antenna: 7.3 kg (16.0 lb.)
Power cable length	15 m (49 ft. 3 in.)
Network cable length	15 m (49 ft. 3 in.)
Antenna rotation speed	24 rpm and 48 rpm NOTE: The antenna can rotate at 48 rpm only when in single range mode, with MotionScope™ disabled, and for range settings of 12 nm or lower.
Maximum wind load	80 kn
Temperature range	From -15 to 55°C (from 5 to 131°F)
Humidity	95% at 35°C (95°F)
Water rating	IEC 60529 IPX6 ²
Bearing accuracy	0.25 degrees

¹ IMPORTANT: The specified 100 W/m² minimum distance must to be maintained between the antenna and the occupational user and the specified 10 W/m² must be maintained between the antenna and the general public. Under such configuration, the radio frequency radiation exposure limits set forth for a population/uncontrolled environment are satisfied.

² Protected against powerful jets of water. Water projected at all angles through a 12.5 mm nozzle at a flow rate of 100 L/min (26.4 gal./min.) at a pressure of 100 kN/m² for 3 min. from a distance of 3 m (9.8 ft.). For more information, go to www.garmin.com/waterrating.

Electrical Specifications

Specification	Measurement
Input voltage	From 10 to 32 Vdc
Fuse	Radar power cable: 15 A, blade-type Voltage converter cable (if applicable): 30 A, blade-type
Input power	GMR Fantom 54 and 56 <ul style="list-style-type: none"> • Typical: 65 W • Maximum: 170 W GMR Fantom 124 and 126 <ul style="list-style-type: none"> • Typical: 80 W • Maximum: 185 W GMR Fantom 254 and 256 <ul style="list-style-type: none"> • Typical: 150 W • Maximum: 260 W

Antenna Specifications

Specification	Measurement
Type	End-fed slotted waveguide
Horizontal beam width	4 ft. antenna: 1.8 degrees 6 ft. antenna: 1.25 degrees
Horizontal side lobes	-23 dB within ±10 degrees of main -30 dB outside ±10 degrees of main
Vertical beam width	22 degrees
Polarization	Horizontal

Open-Source Software License

To view the open-source software license(s) used in this product, go to developer.garmin.com/open-source/linux/.

Installation Troubleshooting

Symptom	Possible Causes
The radar does not turn on. The status LED is not on.	<ul style="list-style-type: none"> • The power cable may not be connected correctly to the device or to the battery. Check all connections. • The inline fuse may have blown. Check the fuse and replace it if necessary. • The wire gauge used to extend the power cable may be too small for the length of the extension. Check the table provided in the Power Cable Extensions section of these instructions to make sure the correct wire gauge is used (<i>Power Cable Extensions</i>, page 3).
The radar is not available on the Garmin device or on devices connected to the Garmin Marine Network.	<ul style="list-style-type: none"> • The radar may not be powering on. Check the status LED. • The device software may not be up-to-date. Update the software on the device or on the Garmin Marine Network. • The network cable may not be connected correctly to the device or to the Garmin Marine Network. Check all connections. • If a field-installable network connector was used, it may have been installed improperly. Check the connector.

The status LED is located on the product label, and can help troubleshoot installation problems.

Status LED Color and Activity	Radar Status
Solid red	The radar is getting ready for use. The LED should be solid red briefly and change to flashing green.
Flashing green	The radar is operating properly.
Flashing orange	The radar software is being updated.
Flashing red	The radar has encountered an error. Contact Garmin product support for assistance.

Contacting Garmin Support

- Go to support.garmin.com for help and information, such as product manuals, frequently asked questions, videos, and customer support.
- In the USA, call 913-397-8200 or 1-800-800-1020.
- In the UK, call 0808 238 0000.
- In Europe, call +44 (0) 870 850 1241.

DRAFT

© 2020 Garmin Ltd. or its subsidiaries

Garmin® and the Garmin logo are trademarks of Garmin Ltd. or its subsidiaries, registered in the USA and other countries. GMR™, Fantom™, and MotionScope™ are trademarks of Garmin Ltd. or its subsidiaries. These trademarks may not be used without the express permission of Garmin.