

FCC/ISED DXX Test Report

Prepared for: Garmin International Inc.

Address: 1200 E. 151st Street
Olathe, Kansas, 66062, USA

Product: A03556

Test Report No: R20190123-20-01B

Approved by:



Nic S. Johnson, NCE

Technical Manager

iNARTE Certified EMC Engineer #EMC-003337-NE

DATE: 17 May 2019

Total Pages: 74

The Nebraska Center for Excellence in Electronics (NCEE) authorizes the above named company to reproduce this report provided it is reproduced in its entirety for use by the company's employees only. Any use that a third party makes of this report, or any reliance on or decisions made based on it, are the responsibility of such third parties. NCEE accepts no responsibility for damages, if any, suffered by any third party as a result of decisions made or actions based on this report. This report applies only to the items tested.

	Report Number:	R20190123-20-01	Rev	B
	Prepared for:	Garmin		

REVISION PAGE

Rev. No.	Date	Description
0	24 April 2019	Original – NJohnson Prepared by KVepuri/CFarrington
A	15 May 2019	Updated bandwidth section to state it was a 99% occupied bandwidth used. Band edge limits section was modified Includes NCEE Labs report R20190123-20-01 and its amendment in full. -NJ
B	17 May 2019	Changed band edge reporting table to show only 15.209 limits. Includes NCEE Labs report R20190123-20-01A and its amendment in full. -NJ



Report Number: R20190123-20-01

Rev

B

Prepared for: Garmin

CONTENTS

Revision Page	2
1.0 Summary of test results	4
2.0 EUT Description	5
2.1 Equipment under test	5
2.2 Description of test modes	6
2.3 Description of support units	6
3.0 Laboratory description.....	7
3.1 Laboratory description.....	7
3.2 Test personnel.....	7
3.3 Test equipment.....	8
4.0 Detailed results.....	9
4.1 Duty Cycle	9
4.2 Peak Output Power	10
4.3 Bandwidth.....	20
4.4 Radiated emissions.....	31
4.5 Band edges	53
4.6 Conducted AC Mains Emissions	68
Appendix A: Sample Calculation	71
Appendix B – Measurement Uncertainty	73
REPORT END.....	74



Report Number:	R20190123-20-01	Rev	B
Prepared for:	Garmin		

1.0 SUMMARY OF TEST RESULTS

The EUT has been tested according to the following specifications:

- (1) US Code of Federal Regulations, Title 47, Part 15
- (2) ISED RSS-Gen, Issue 5
- (3) ISED RSS-210, Issue 9

SUMMARY			
Requirement	Test Type and Limit	Result	Remark
FCC 15.203	Unique Antenna Requirement	Pass	PCB Antenna
FCC 15.35 RSS-Gen, 6.10	Duty cycle of pulsed emissions	N/A	Not required
NA	Maximum Peak Output Power	N/A	Informational Purpose Only
NA	Minimum Bandwidth	N/A	Informational Purpose Only
FCC 15.209 RSS-Gen, 7.1	Receiver Radiated Emissions	Pass	Meets the requirement of the limit.
FCC 15.209 RSS-Gen, 8.9 RSS-210 A1.2 FCC 15.249(a)	Transmitter Radiated Emissions	Pass	Meets the requirement of the limit.
FCC 15.209, 15.205, 15.249(d) RSS-Gen, 8.9 RSS-210, 5.5	Band Edge Measurement	Pass	Meets the requirement of the limit.
FCC 15.207 RSS-Gen. 8.8	Conducted AC Emissions	Pass	Meets the requirement of the limit.



Report Number:	R20190123-20-01	Rev	B
Prepared for:	Garmin		

2.0 EUT DESCRIPTION

2.1 EQUIPMENT UNDER TEST

Summary

The Equipment Under Test (EUT) was a battery powered GFSK, GMSK and GFSK (BT BR) transceiver manufactured by GARMIN inc.

EUT	A03356
EUT Received	22 March 2019
EUT Tested	26 March 2019- 24 April 2019
Serial No.	3985900303bw00 (used for radiated tests); 3985900336bw00 (used for conducted tests)
Operating Band	2400 – 2483.5 MHz
Device Type	GFSK, GMSK, GFSK (BT BR) transceiver
Power Supply	Internal Battery/ Charger: Garmin (Phi Hong) MN: PSAI10R-050Q

NOTE: For more detailed features description, please refer to the manufacturer's specifications or user's manual.



Report Number:	R20190123-20-01	Rev	B
Prepared for:	Garmin		

2.2 DESCRIPTION OF TEST MODES

The EUT operates on, and was tested at the frequencies below:

Channel	Frequency
Low	2402 MHz
Mid	2440 MHz
High	2480 MHz

These are the only three representative channels tested in the frequency range according to FCC Part 15.31 and RSS-Gen Table A1. See the operational description for a list of all channel frequency and designations.

This EUT was set to transmit in a worse-case scenario with modulation on. The manufacturer modified the unit to transmit continuously on the lowest, middle and highest frequency channels.

The EUT was tested on both battery and external USB.

2.3 DESCRIPTION OF SUPPORT UNITS

None

3.0 LABORATORY DESCRIPTION

3.1 LABORATORY DESCRIPTION

All testing was performed at the following Facility:

The Nebraska Center for Excellence in Electronics (NCEE Labs)
 4740 Discovery Drive
 Lincoln, NE 68521

A2LA Certificate Number:	1953.01
FCC Accredited Test Site Designation No:	US1060
Industry Canada Test Site Registration No:	4294A-1
NCC CAB Identification No:	US0177

Environmental conditions varied slightly throughout the tests:

Relative humidity of $35 \pm 4\%$
 Temperature of $22 \pm 3^\circ$ Celsius



3.2 TEST PERSONNEL

No.	PERSONNEL	TITLE	ROLE
1	Nic Johnson	Technical Manager	Review/editing
2	Karthik Vepuri	Test Engineer	Testing and report
3	Caleb Farrington	Test Technician	Testing and report

Notes:

All personnel are permanent staff members of NCEE Labs. No testing or review was sub-contracted or performed by sub-contracted personnel.



Report Number:	R20190123-20-01	Rev	B
Prepared for:	Garmin		

3.3 TEST EQUIPMENT

DESCRIPTION AND MANUFACTURER	MODEL NO.	SERIAL NO.	LAST CALIBRATION DATE	CALIBRATION DUE DATE
Rohde & Schwarz Test Receiver	ES126	100037	30 Jan 2018	30 Jan 2020
EMCO Biconilog Antenna	3142B	1647	02 Aug 2017	02 Aug 2019
EMCO Horn Antenna	3115	6416	26 Jan 2018	26 Jan 2020
EMCO Horn Antenna	3116	2576	31 Jan 2018	31 Jan 2020
Rohde & Schwarz Preamplifier	TS-PR18	3545700803	09 Mar 2018*	09 Mar 2020*
Trilithic High Pass Filter	6HC330	23042	09 Mar 2018*	09 Mar 2020*
Rohde & Schwarz LISN	ESH3-Z5	836679/010	26 Jul 2018	26 Jul 2019
RF Cable (preamplifier to antenna)	MFR-57500	01-07-002	09 Mar 2018*	09 Mar 2020*
RF Cable (antenna to 10m chamber bulkhead)	FSCM 64639	01E3872	09 Mar 2018*	09 Mar 2020*
RF Cable (10m chamber bulkhead to control room bulkhead)	FSCM 64639	01E3874	09 Mar 2018*	09 Mar 2020*
RF Cable (Control room bulkhead to RF switch)	FSCM 64639	01E3871	09 Mar 2018*	09 Mar 2020*
RF Cable (RF switch to test receiver)	FSCM 64639	01F1206	09 Mar 2018*	09 Mar 2020*
RF switch – Rohde and Schwarz	TS-RSP	1113.5503.14	09 Mar 2018*	09 Mar 2020*
N connector bulkhead (10m chamber)	PE9128	NCEEBH1	09 Mar 2018*	09 Mar 2020*
N connector bulkhead (control room)	PE9128	NCEEBH2	09 Mar 2018*	09 Mar 2020*

*Internal Characterization

Notes:

All equipment is owned by NCEE Labs and stored permanently at NCEE Labs facilities.



Report Number:	R20190123-20-01	Rev	B
Prepared for:	Garmin		

4.0 DETAILED RESULTS

4.1 DUTY CYCLE

Test Method: NA

4.2 PEAK OUTPUT POWER

Test Method: N/A

For Informational Purposes only

Test procedures:

1. The EUT was connected to the spectrum analyzer directly with a low-loss shielded coaxial cable
2. The resolution bandwidth was set to 10 MHz and the video bandwidth was set to 10 MHz to capture the signal. The analyzer used a peak detector in max hold mode.

Deviations from test standard:

No deviation.

Test setup:

The field strength was measured by connecting the EUT directly to the spectrum analyzer. See Section 4.2.

EUT operating conditions:

The EUT was powered by internal battery power unless specified and set to transmit continuously on the lowest frequency channel, highest frequency channel and one in the middle of its operating range. EUT was set to transmit in GMSK and GFSK.

Test results:

Peak Output Power

CHANNEL	CHANNEL FREQUENCY (MHz)	PEAK OUTPUT POWER (dBm)	PEAK OUTPUT POWER (mW)	Method	Transmitter
1	2402	-0.46	0.90	Conducted	GFSK
2	2440	0.63	1.16	Conducted	GFSK
3	2480	1.41	1.38	Conducted	GFSK
1	2402	-1.28	0.74	Conducted	GMSK
2	2440	0.77	1.19	Conducted	GMSK
3	2480	1.54	1.43	Conducted	GMSK
1	2402	0.49	1.12	Conducted	GFSK (BTBR)
2	2440	1.29	1.35	Conducted	GFSK (BTBR)
3	2480	2.17	1.65	Conducted	GFSK (BTBR)



Marker 1 [T1] RBW 10 MHz RF Att 40 dB
 Ref Lvl -0.46 dBm VBW 10 MHz
 26 dBm 2.40185972 GHz SWT 5 ms Unit dBm

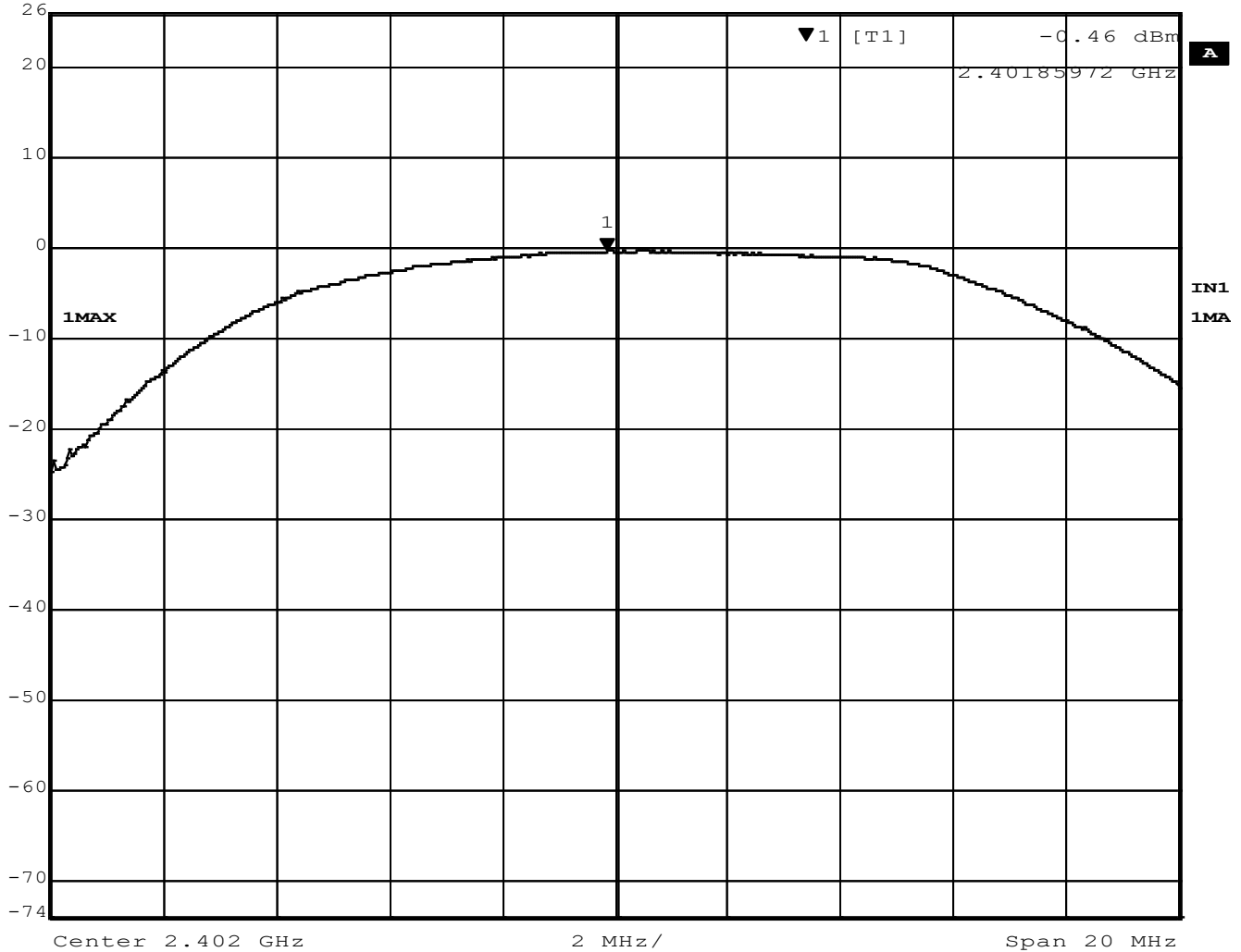

Figure 1 – Output Power, Low Channel, GFSK

Output power -0.46 dBm

Cable loss was less than 0.1 dB and not included



Marker 1 [T1] RBW 10 MHz RF Att 40 dB
 Ref Lvl 0.63 dBm VBW 10 MHz
 26 dBm 2.44053908 GHz SWT 5 ms Unit dBm

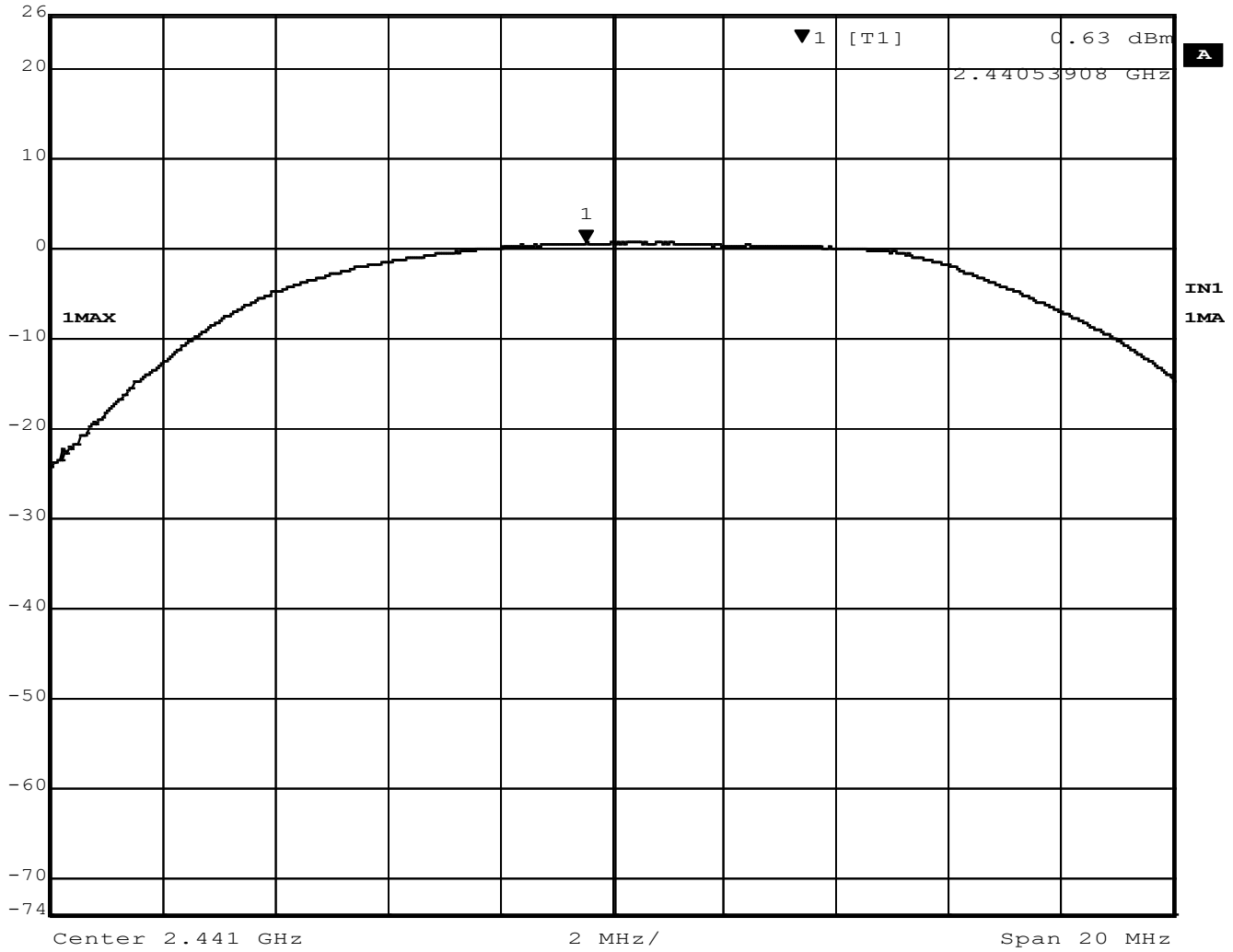

Figure 2 – Output Power, Mid Channel, GFSK

Output power = 0.63 dBm

Cable loss was less than 0.1 dB and not included



Marker 1 [T1]	RBW	10 MHz	RF Att	40 dB
Ref Lvl	1.41 dBm	VBW	10 MHz	
26 dBm	2.47953908 GHz	SWT	5 ms	Unit dBm

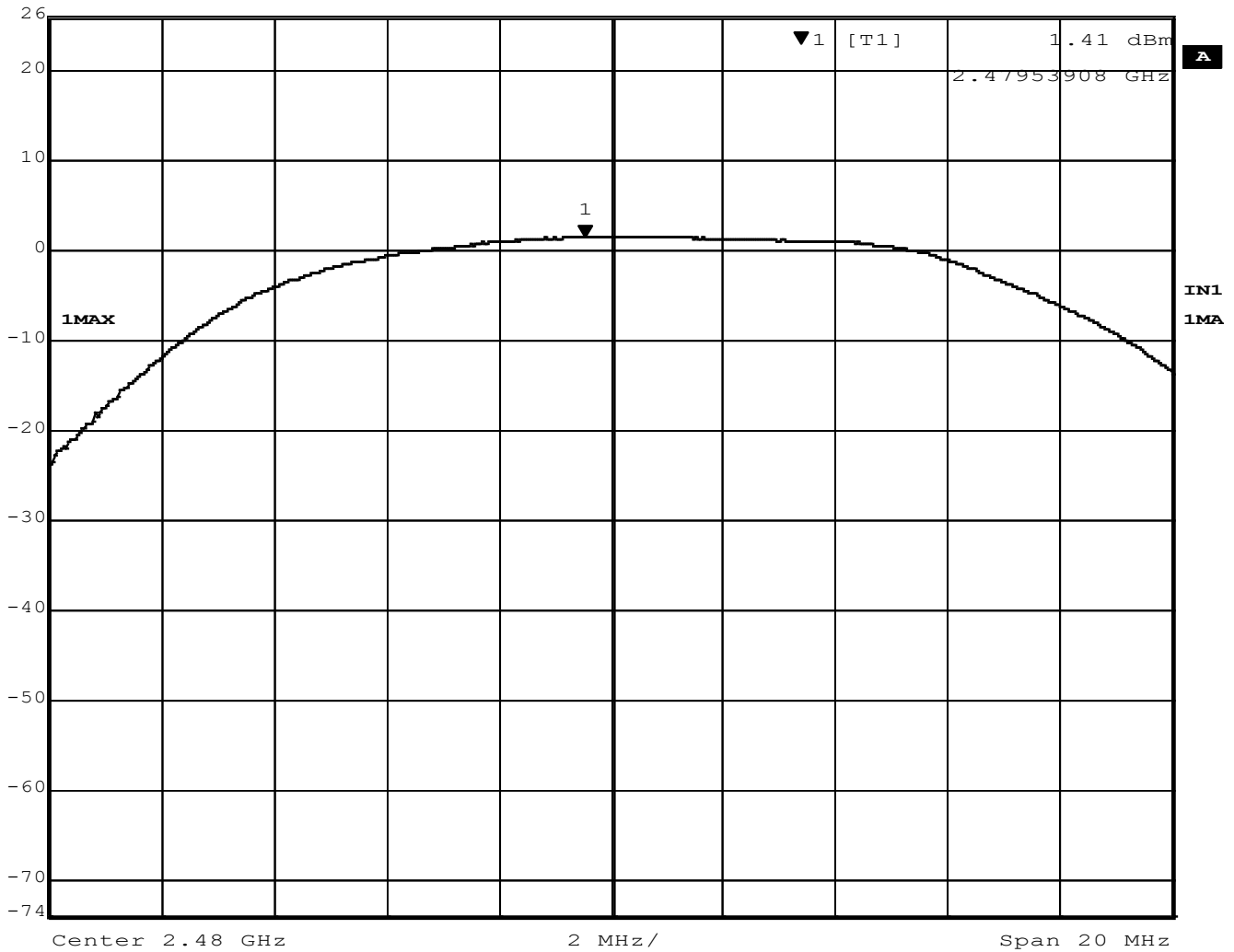

Figure 3 – Output Power, High Channel, GFSK

Output power = 1.41 dBm

Cable loss was less than 0.1 dB and not included



Marker 1 [T1]	RBW	10 MHz	RF Att	40 dB
Ref Lvl	-1.28 dBm	VBW	10 MHz	
26 dBm	2.40254108 GHz	SWT	5 ms	Unit dBm

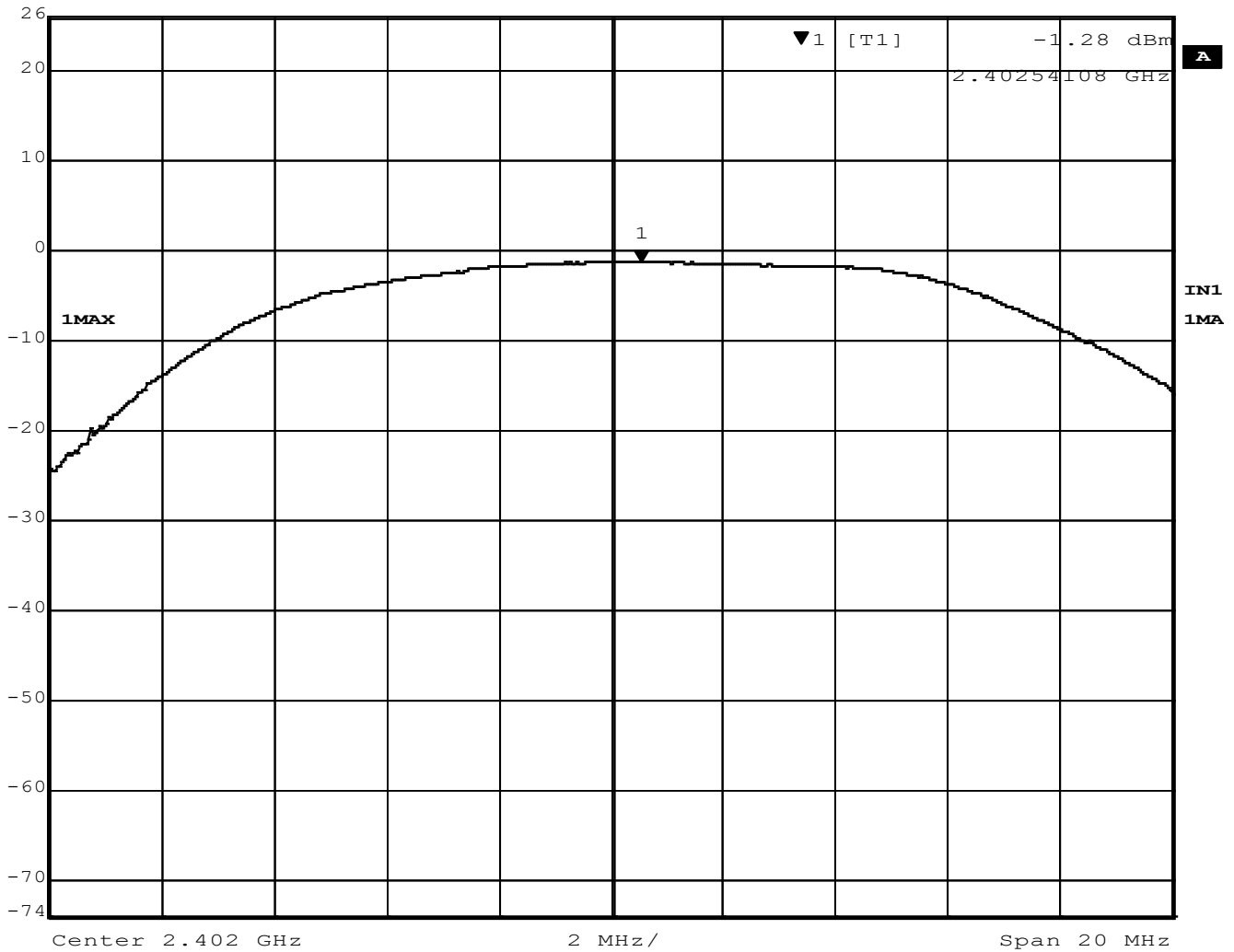

Figure 4 - Output Power, Low Channel, GMSK

Output power = -1.28 dBm

Cable loss was less than 0.1 dB and not included



Ref Lvl	Marker 1 [T1]	RBW	10 MHz	RF Att	40 dB
26 dBm	0.77 dBm	VBW	10 MHz		
	2.43933868 GHz	SWT	5 ms	Unit	dBm

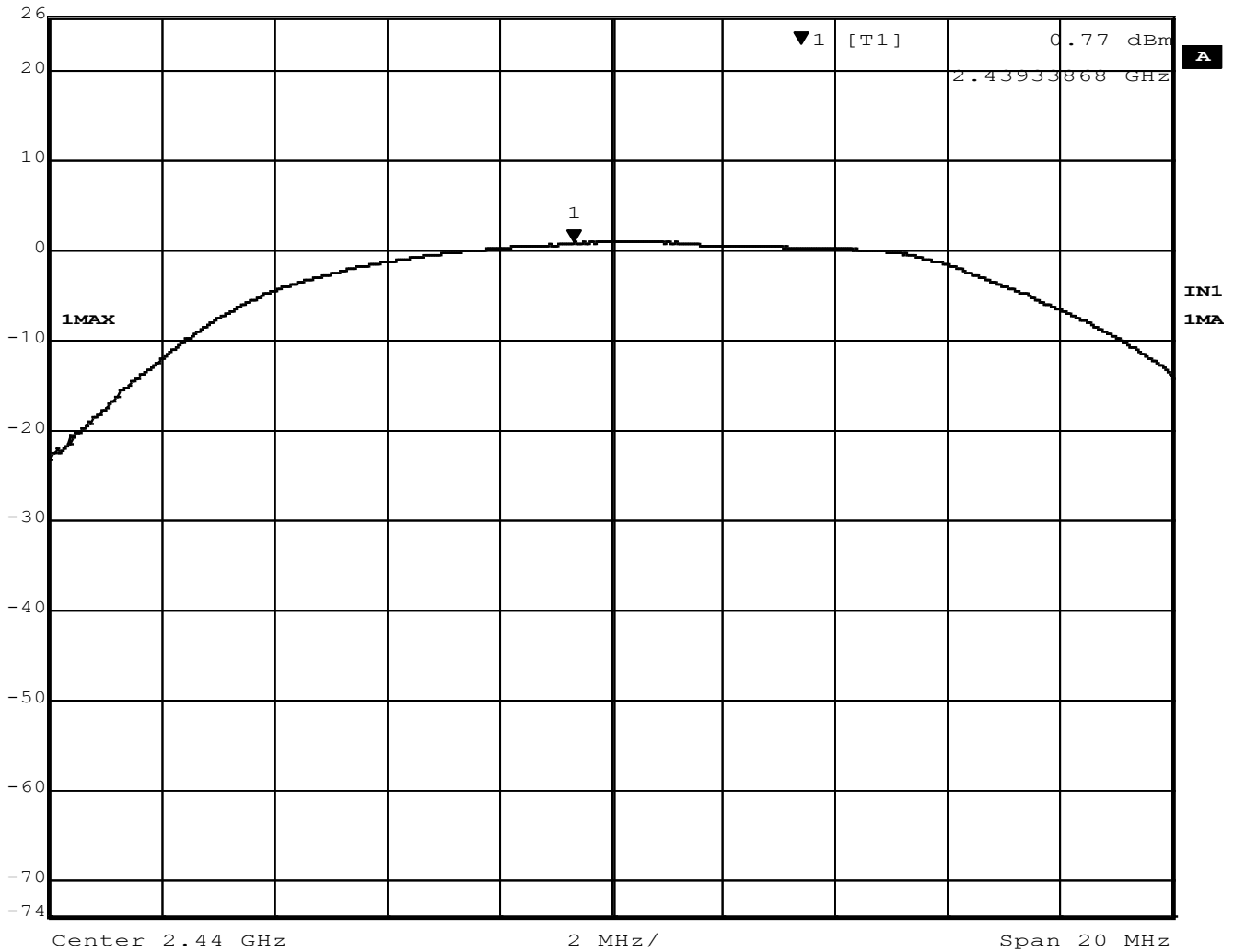

Figure 5 - Output Power, Mid Channel, GMSK

Output power = 0.77 dBm

Cable loss was less than 0.1 dB and not included



Marker 1 [T1]	RBW	10 MHz	RF Att	40 dB
Ref Lvl	1.54 dBm	VBW	10 MHz	
26 dBm	2.48010020 GHz	SWT	5 ms	Unit dBm

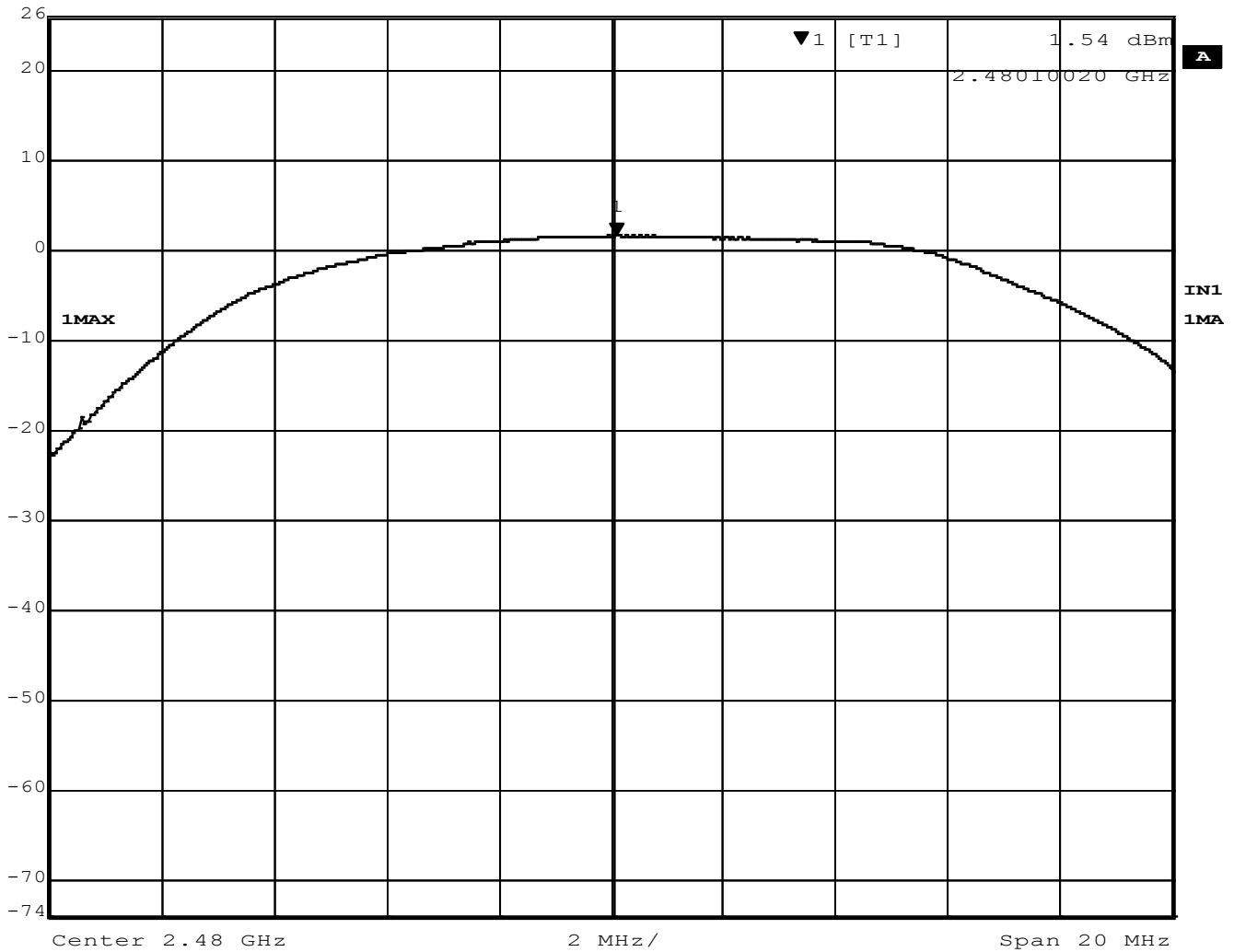

Figure 6 - Output Power, High Channel, GMSK

Output power = 1.54 dBm

Cable loss was less than 0.1 dB and not included



Marker 1 [T1]	RBW	10 MHz	RF Att	40 dB
Ref Lvl	0.49 dBm	VBW	10 MHz	
26 dBm	2.40165932 GHz	SWT	5 ms	Unit dBm

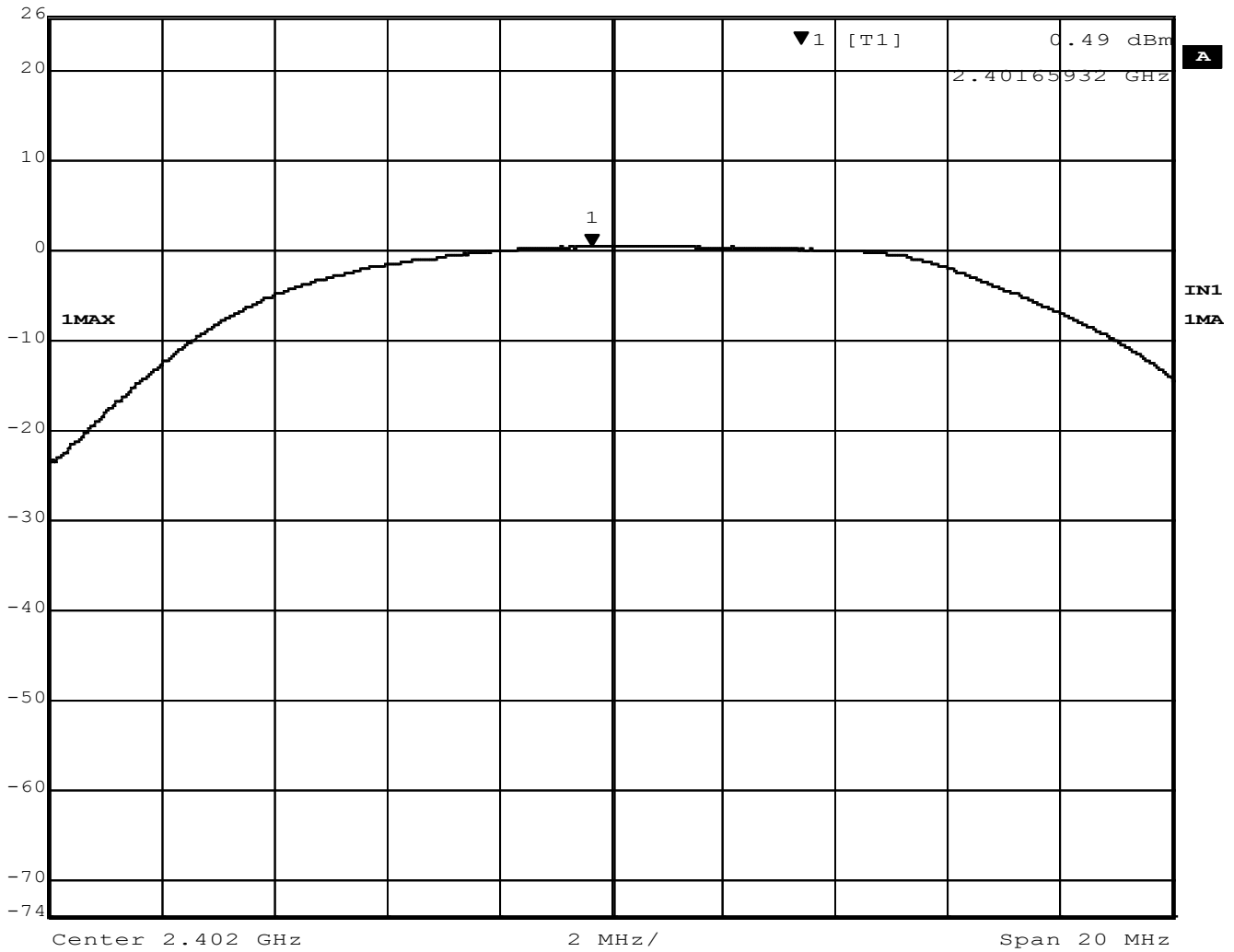

Figure 7 – Output Power, Low Channel, GFSK (BT BR)

Output power 0.49 dBm

Cable loss was less than 0.1 dB and not included



Marker 1 [T1] RBW 10 MHz RF Att 40 dB
 Ref Lvl 1.29 dBm VBW 10 MHz
 26 dBm 2.44089980 GHz SWT 5 ms Unit dBm

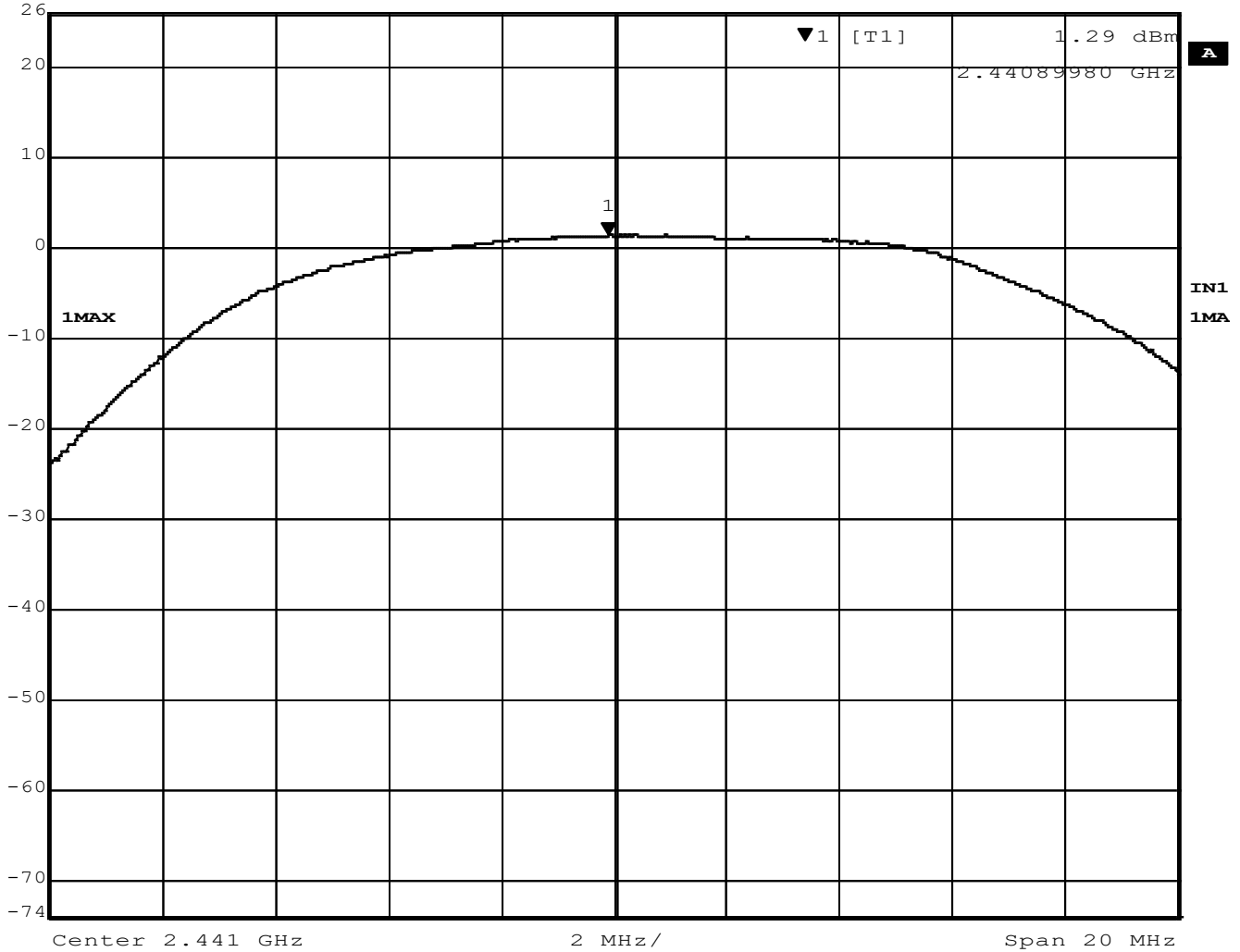

Figure 8 – Output Power, Mid Channel, GFSK (BT BR)

Output power = 1.29 dBm

Cable loss was less than 0.1 dB and not included



Marker 1 [T1]	RBW	10 MHz	RF Att	40 dB
Ref Lvl	2.17 dBm	VBW	10 MHz	
26 dBm	2.47953908 GHz	SWT	5 ms	Unit dBm

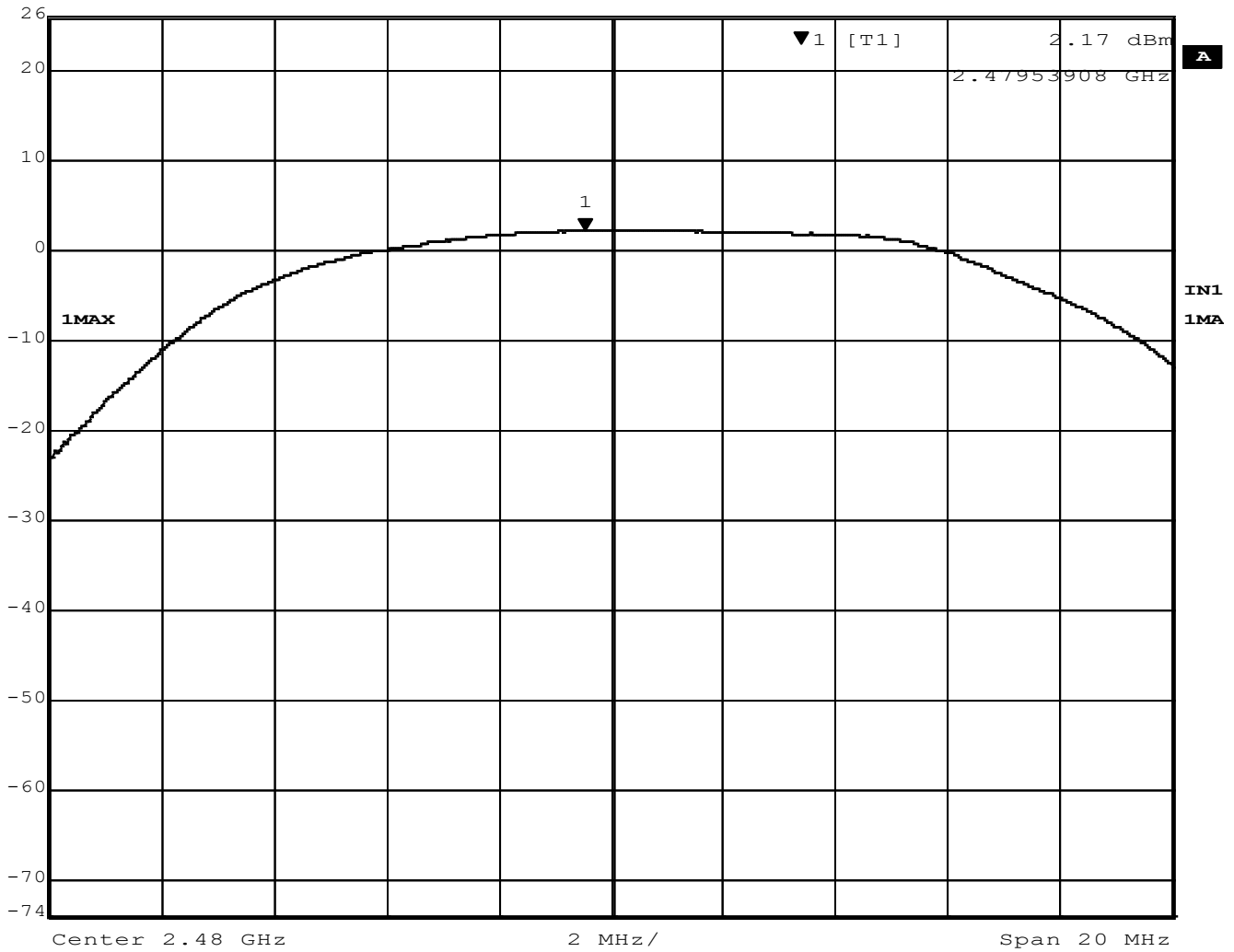

Figure 9 – Output Power, High Channel, GFSK (BT BR)

Output power = 2.17 dBm

Cable loss was less than 0.1 dB and not included



Report Number:	R20190123-20-01	Rev	B
Prepared for:	Garmin		

4.3 BANDWIDTH

Test Method: ANSI C63.10-2013, Section(s) 6.9.3

Limits of bandwidth measurements:

For Informational Purposes only

Test procedures:

1. The EUT was connected to the spectrum analyzer directly with a low-loss shielded coaxial cable
2. The 99% Occupied Bandwidth was measured using the spectrum analyzer's occupied bandwidth function.

Test setup:

The field strength was measured by connecting the EUT directly to the spectrum analyzer.

Deviations from test standard:

No deviation.

Test setup:

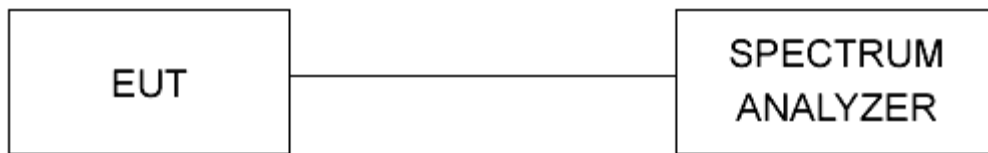

Figure 10 - Bandwidth Measurements Test Setup

EUT operating conditions:

The EUT was powered by internal battery power unless specified and set to transmit continuously on the lowest frequency channel, highest frequency channel and one in the middle of its operating range. EUT was set to transmit in GMSK and GFSK.

Test results:

99% Occupied Bandwidth

CHANNEL	Mode	CHANNEL FREQUENCY (MHz)	OBW (KHz)	RESULT
Low	GFSK	2402	967.94	PASS
Mid	GFSK	2440	967.94	PASS
High	GFSK	2480	973.95	PASS
Low	GMSK	2402	1064.13	PASS
Mid	GMSK	2440	1052.10	PASS
High	GMSK	2480	1052.10	PASS
Low	GFSK (BTBR)	2402	973.95	PASS
Mid	GFSK (BTBR)	2440	961.92	PASS
High	GFSK (BTBR)	2480	979.96	PASS



Marker 1 [T1] RBW 100 kHz RF Att 30 dB
 Ref Lvl -1.19 dBm VBW 300 kHz
 20 dBm 2.40185271 GHz SWT 5 ms Unit dBm

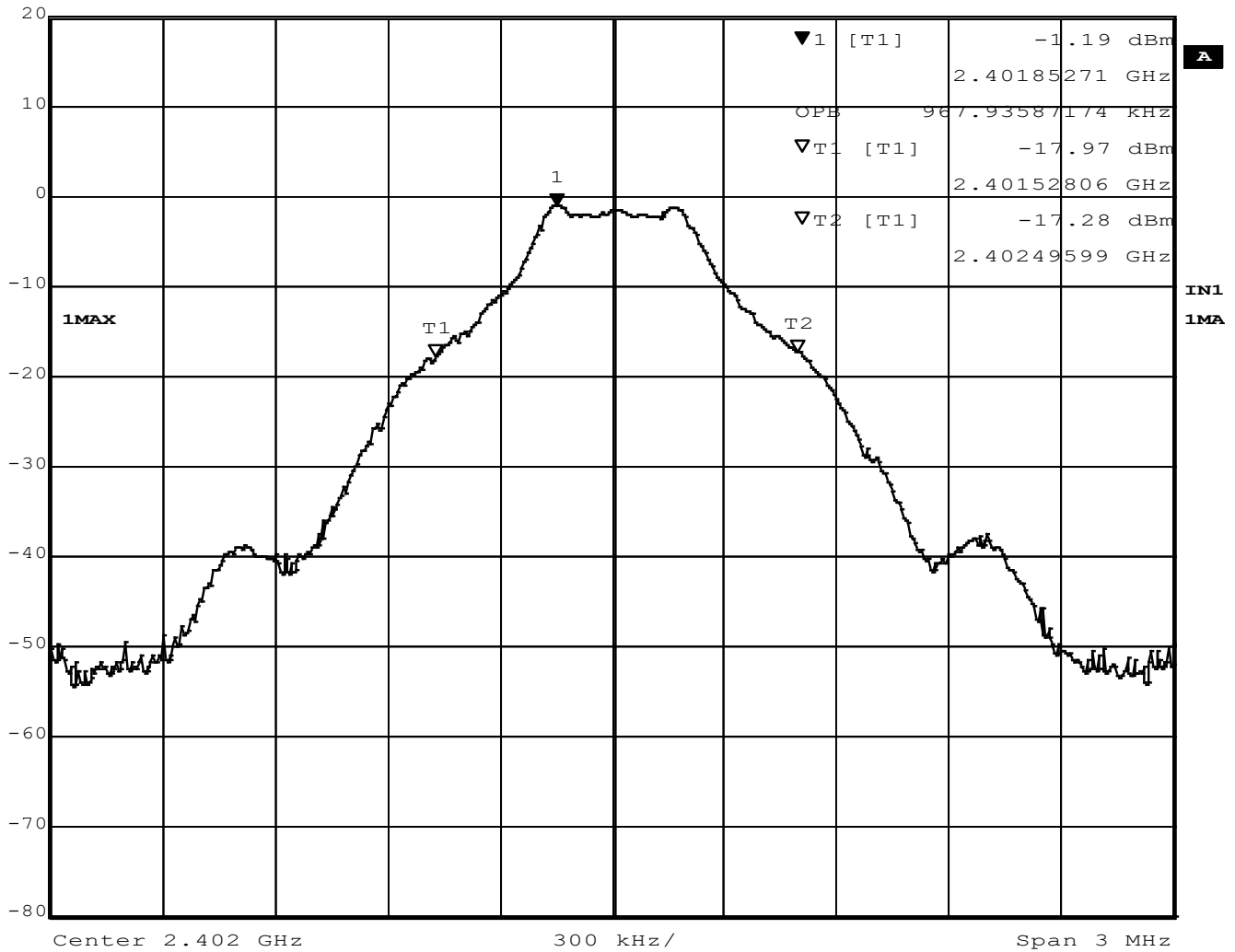

Figure 11 - Occupied Bandwidth, Low Channel, GFSK



Marker 1 [T1]	RBW	100 kHz	RF Att	30 dB
Ref Lvl	-0.15 dBm	VBW	300 kHz	
20 dBm	2.44085271 GHz	SWT	5 ms	Unit dBm

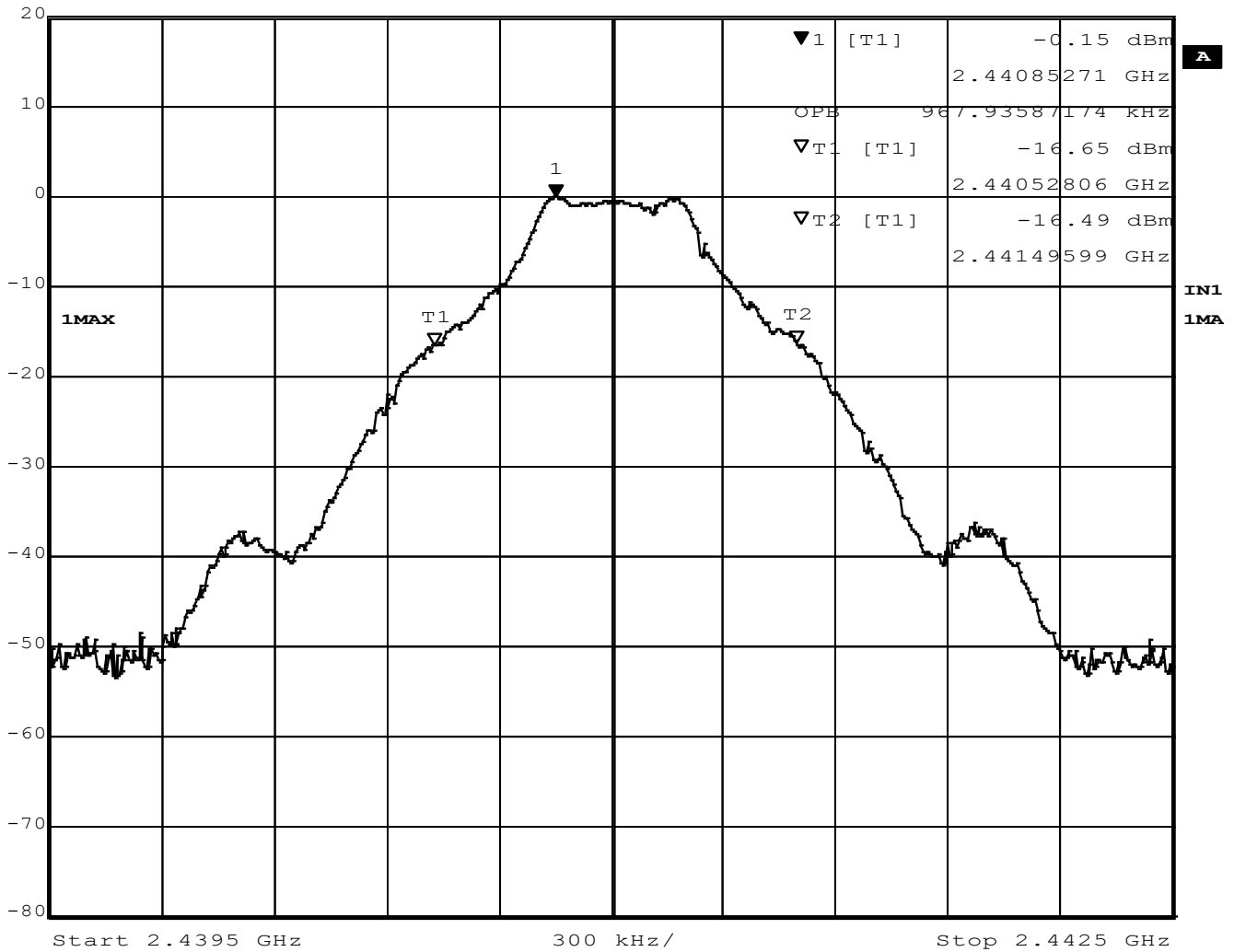

Figure 12 - Occupied Bandwidth, Mid Channel, GFSK



Marker 1 [T1] RBW 100 kHz RF Att 30 dB
 Ref Lvl 0.76 dBm VBW 300 kHz
 20 dBm 2.47984669 GHz SWT 5 ms Unit dBm

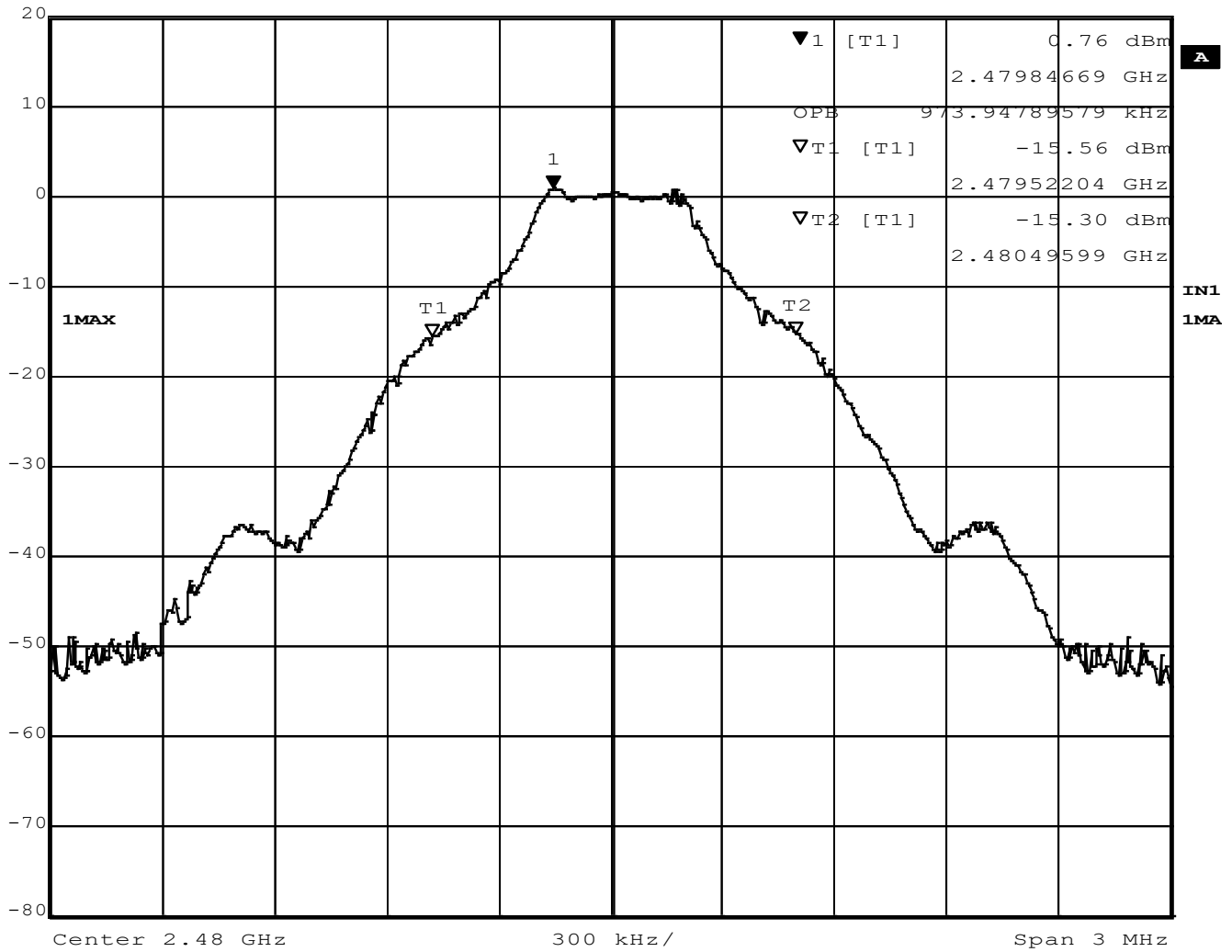

Figure 13 - Occupied Bandwidth, High Channel, GFSK



Marker 1 [T1] RBW 100 kHz RF Att 30 dB
 Ref Lvl -2.94 dBm VBW 300 kHz
 20 dBm 2.40225551 GHz SWT 5 ms Unit dBm

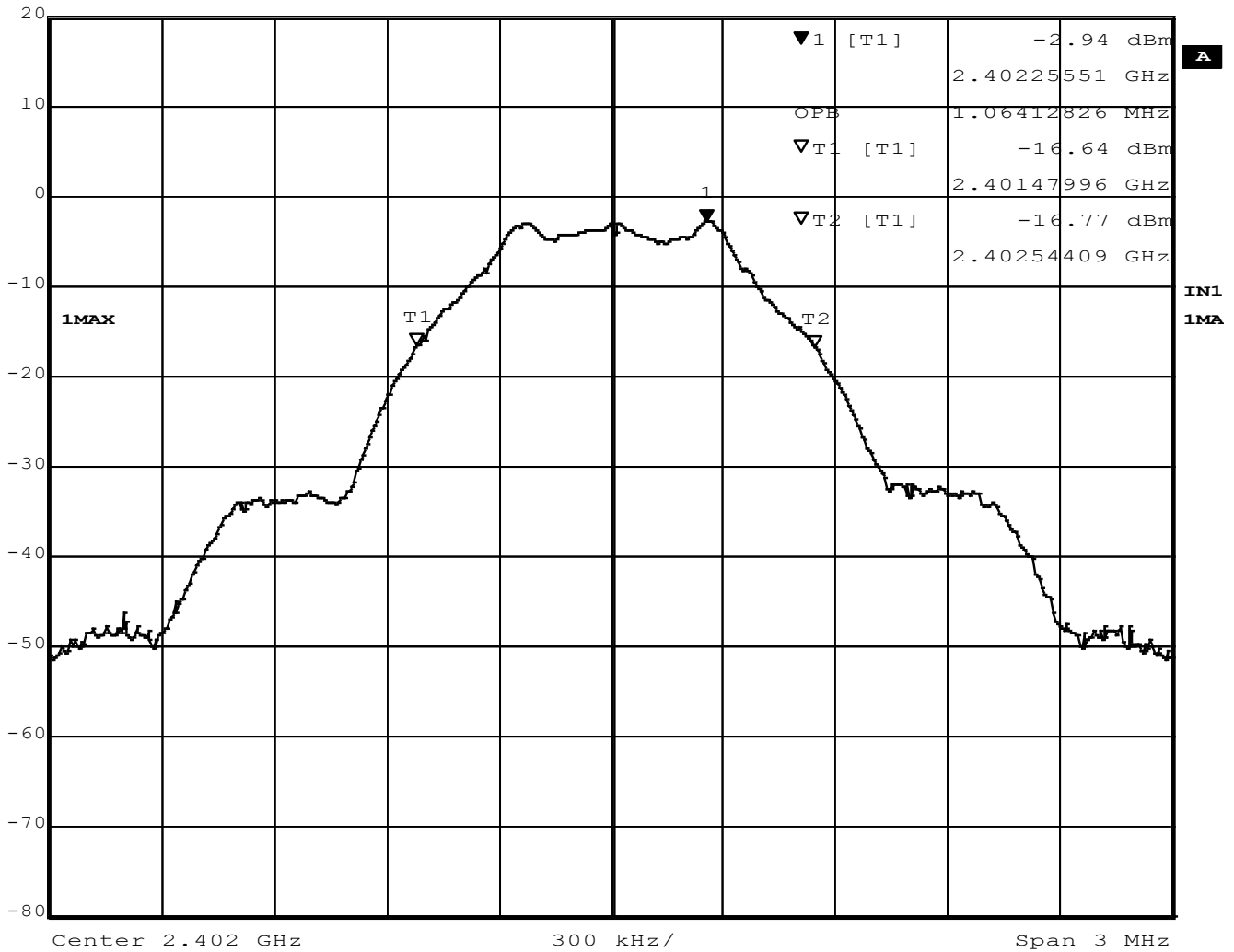

Figure 14 – Occupied Bandwidth, Low Channel, GMSK



Marker 1 [T1] RBW 100 kHz RF Att 30 dB
 Ref Lvl -0.86 dBm VBW 300 kHz
 20 dBm 2.44026152 GHz SWT 5 ms Unit dBm

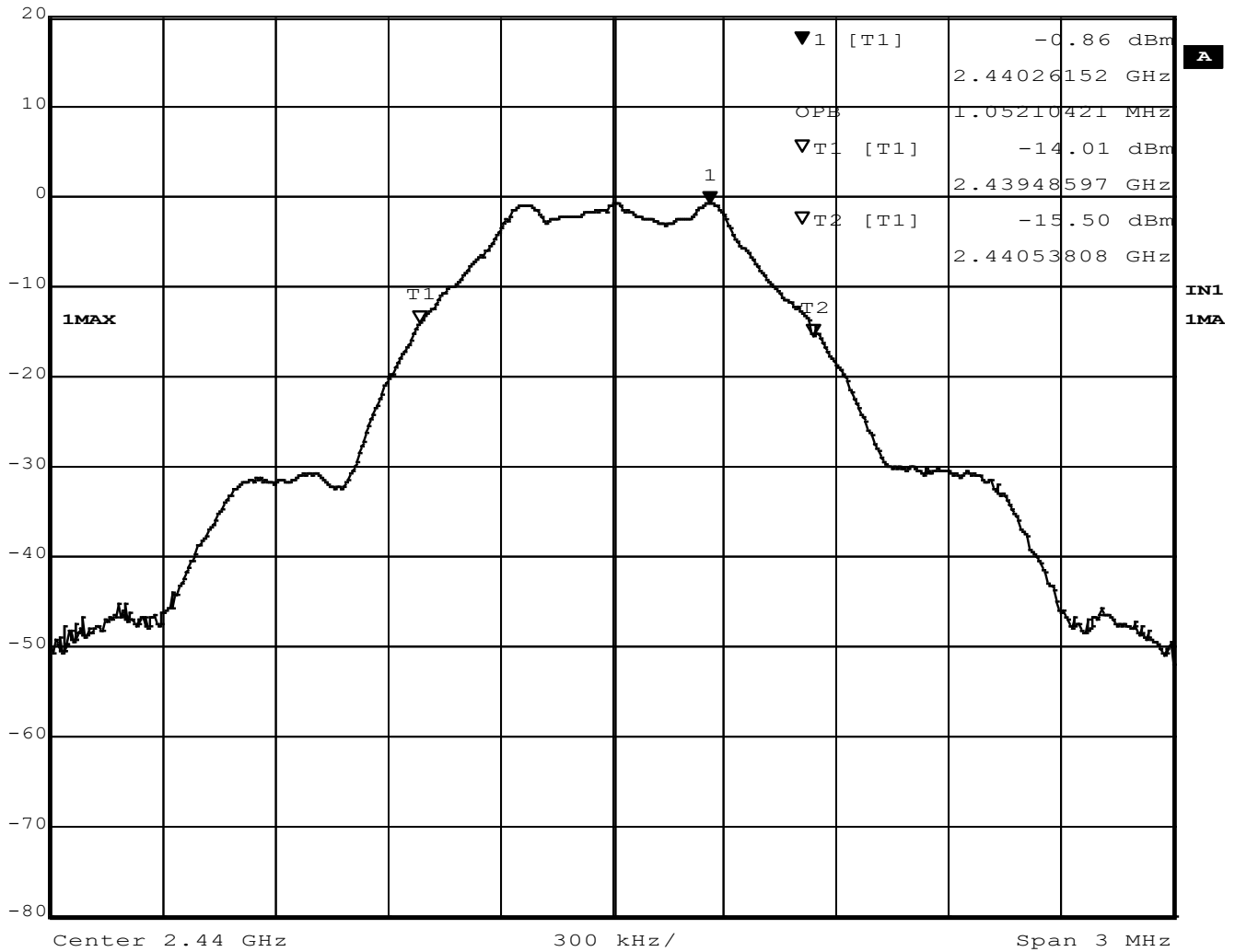

Figure 15 - Occupied Bandwidth, Mid Channel, GMSK



Marker 1 [T1] RBW 100 kHz RF Att 30 dB
 Ref Lvl 0.23 dBm VBW 300 kHz
 20 dBm 2.48025551 GHz SWT 5 ms Unit dBm

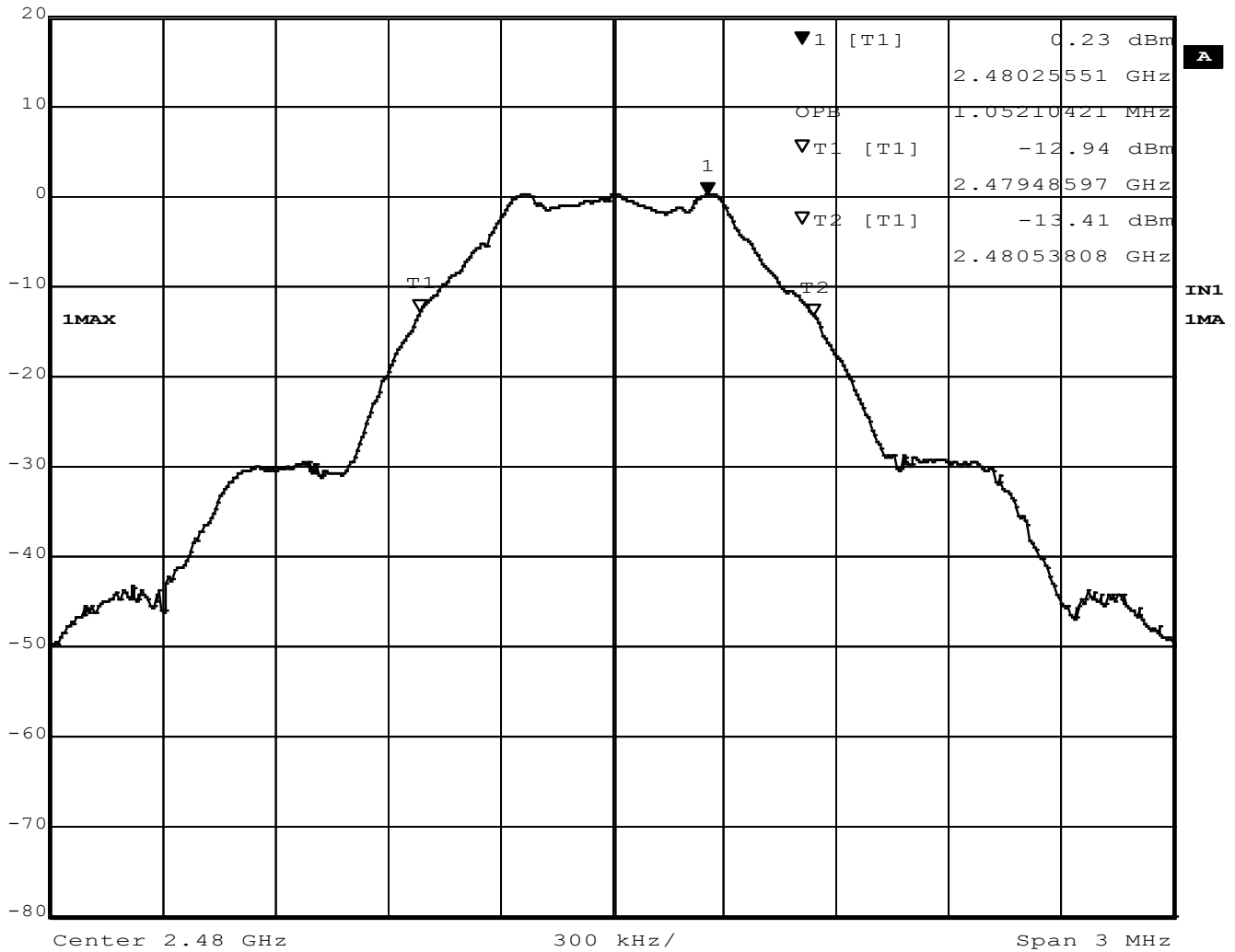

Figure 16 - Occupied Bandwidth, High Channel, GMSK



Marker 1 [T1] RBW 100 kHz RF Att 30 dB

Ref Lvl -1.02 dBm VBW 300 kHz
 20 dBm 2.40217134 GHz SWT 5 ms Unit dBm

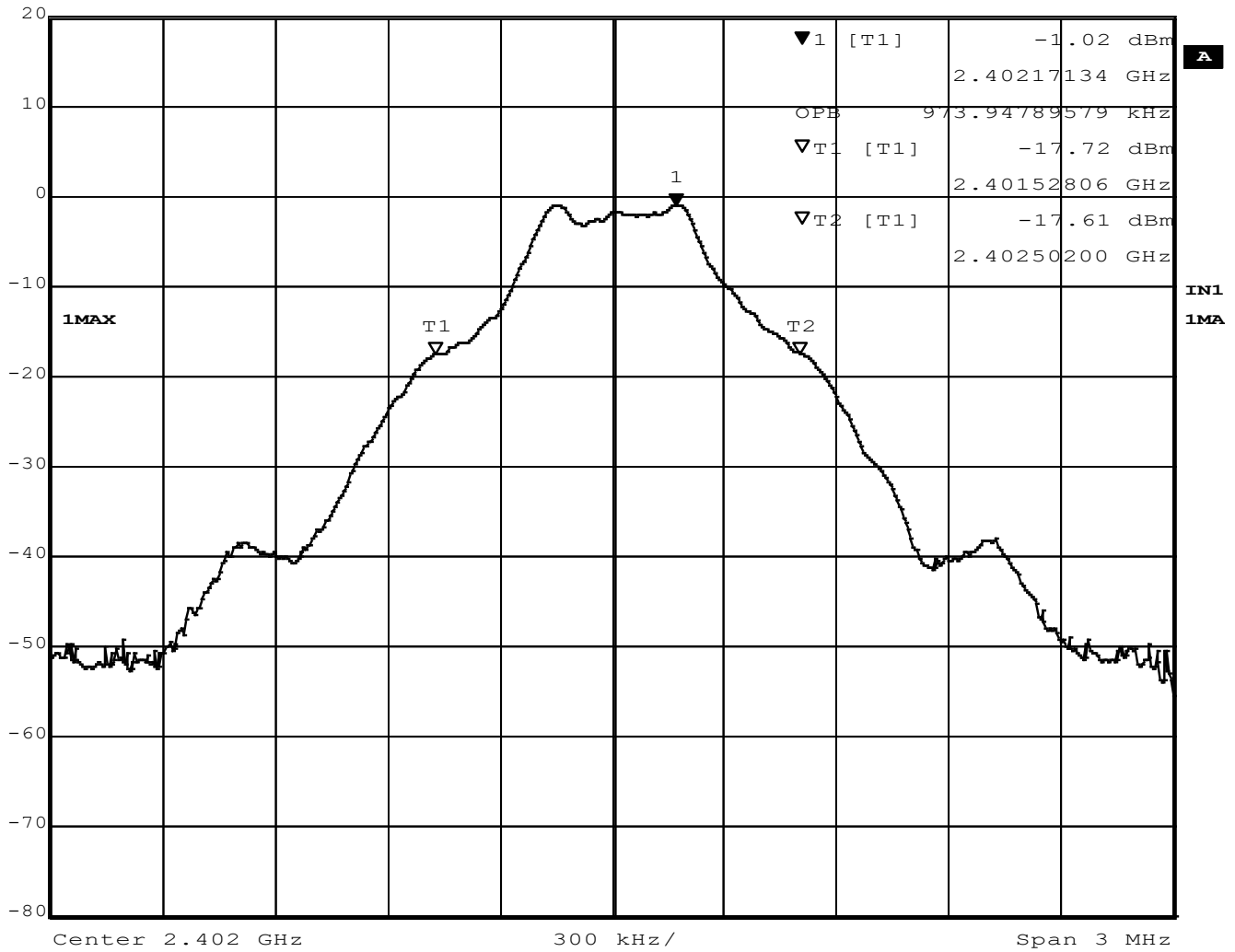

Figure 17 - Occupied Bandwidth, Low Channel, GFSK (BT BR)



Marker 1 [T1] RBW 100 kHz RF Att 30 dB
 Ref Lvl -0.07 dBm VBW 300 kHz
 20 dBm 2.44117134 GHz SWT 5 ms Unit dBm

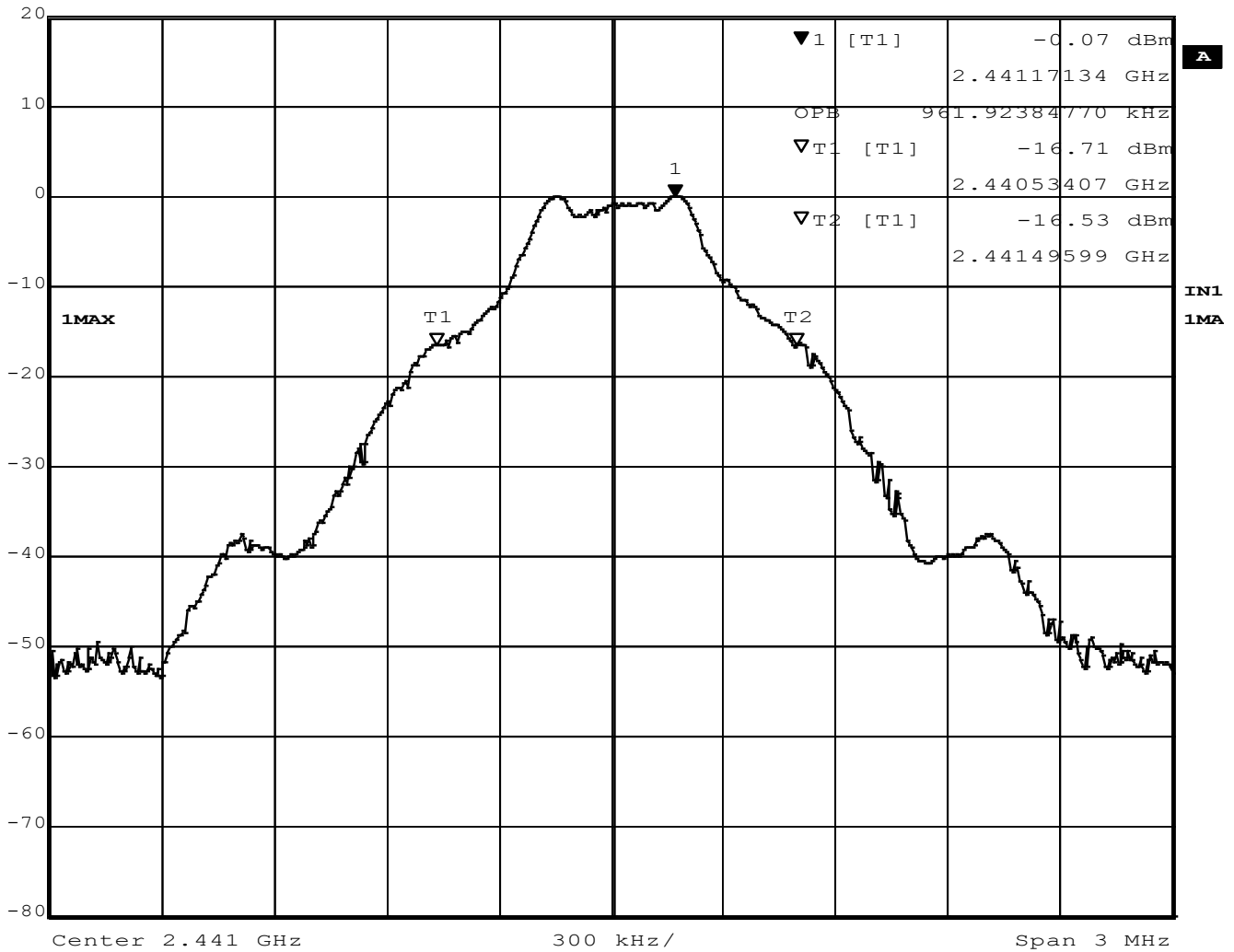

Figure 18 - Occupied Bandwidth, Mid Channel, GFSK (BT BR)



Marker 1 [T1] RBW 100 kHz RF Att 30 dB
 Ref Lvl 0.92 dBm VBW 300 kHz
 20 dBm 2.48017134 GHz SWT 5 ms Unit dBm

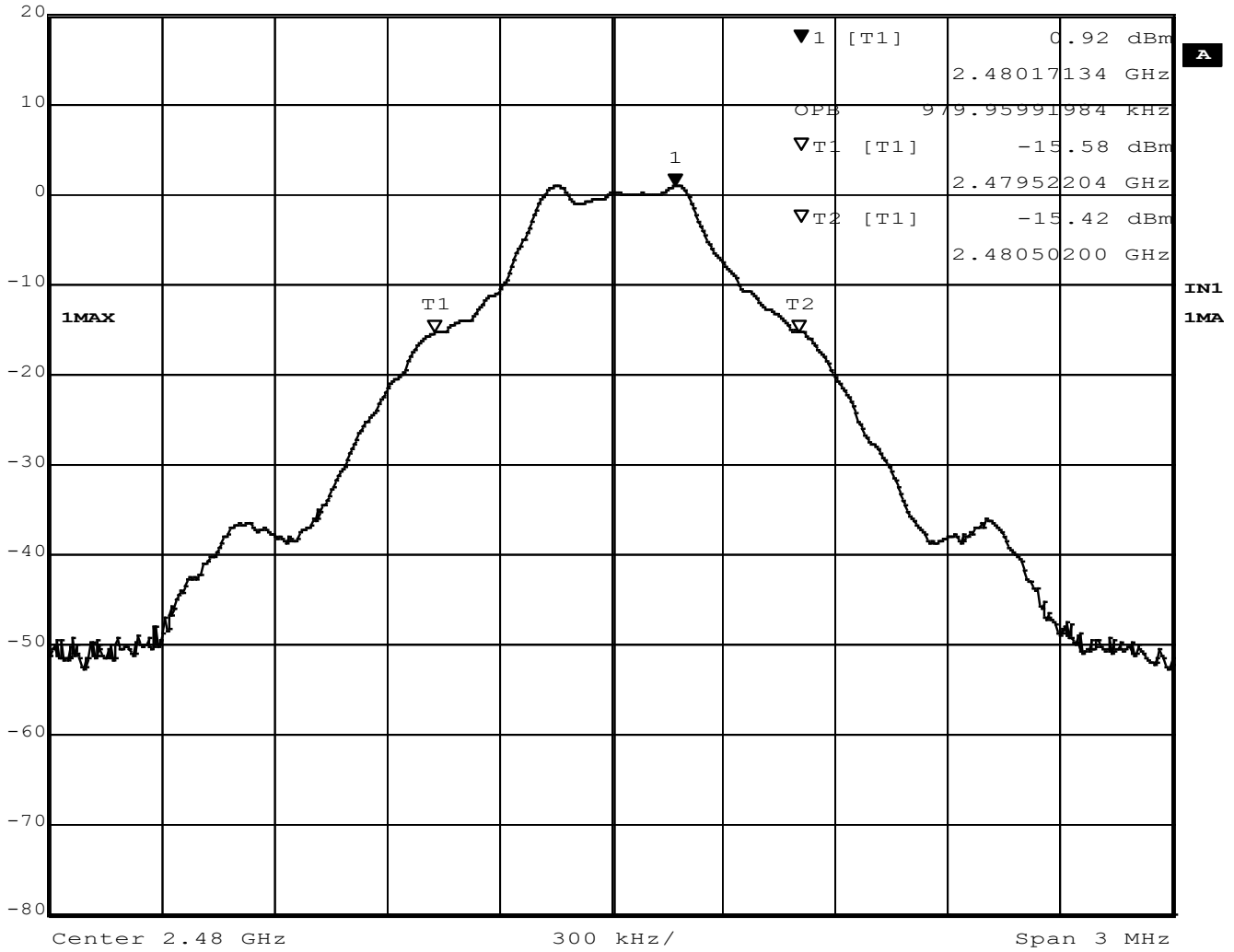

Figure 19 - Occupied Bandwidth, High Channel, GFSK (BT BR)

4.4 RADIATED EMISSIONS

Test Method: ANSI C63.10-2013, Section 6.5, 6.6

Limits for radiated emissions measurements:

Emissions radiated outside of the specified bands shall be applied to the limits in 15.209 as followed:

FREQUENCIES (MHz)	FIELD STRENGTH ($\mu\text{V/m}$)	MEASUREMENT DISTANCE (m)
0.009-0.490	2400/F(kHz)	300
0.490-1.705	24000/F(kHz)	30
1.705-30.0	30	3
30-88	100	3
88-216	150	3
216-960	200	3
Above 960	500	3

NOTE:

1. The lower limit shall apply at the transition frequencies.
2. Emission level (dBuV/m) = $20 * \log * \text{Emission level } (\mu\text{V/m})$.
3. As shown in 15.35(b), for frequencies above 1000MHz, the field strength limits are based on average detector, however, the peak field strength of any emission shall not exceed the maximum permitted average limits by more than 20dB under any condition of modulation.
4. The EUT was tested for spurious emissions while running off of battery power and external USB power. The worse-case emissions were produced while running off of USB power, so results from this mode are presented.

Report Number:	R20190123-20-01	Rev	B
Prepared for:	Garmin		

Test procedures:

- a. The EUT was placed on the top of a rotating table above the ground plane in a 10 meter semi-anechoic chamber. The table was rotated 360 degrees to determine the position of the highest radiation. The table was 0.8m high for measurements from 30MHz-1Ghz and 1.5m for measurements from 1GHz and higher.
- b. The EUT was set 3 meters away from the interference-receiving antenna, which was mounted on the top of a variable-height antenna tower.
- c. The antenna was a broadband antenna, and its height is varied from one meter to four meters above the ground to determine the maximum value of the field strength. Both horizontal and vertical polarizations of the antenna are used to make the measurement.
- d. For each suspected emission, the EUT was arranged to maximize its emissions and then the antenna height was varied from 1 meter to 4 meters and the rotating table was turned from 0 degrees to 360 degrees to find the maximum emission reading.
- e. The test-receiver system was set to use a peak detector with a specified resolution bandwidth. For spectrum analyzer measurements, the composite maximum of several analyzer sweeps was used for final measurements.
- f. If the emission level of the EUT in peak mode was 10dB lower than the limit specified, then testing could be stopped and the peak values of the EUT would be reported. Otherwise the emissions that did not have 10 dB margin would be re-tested one by one using peak, quasi-peak or average method as specified and then reported in a data sheet.
- g. The EUT was maximized in all 3 orthogonal positions. The results are presented for the axis that had the highest emissions.
- h. The EUT was tested on both battery and external USB. The worse-case orientation was found during the preview scan, and it was with the USB, so that was used for the remainder of testing

Test setup:

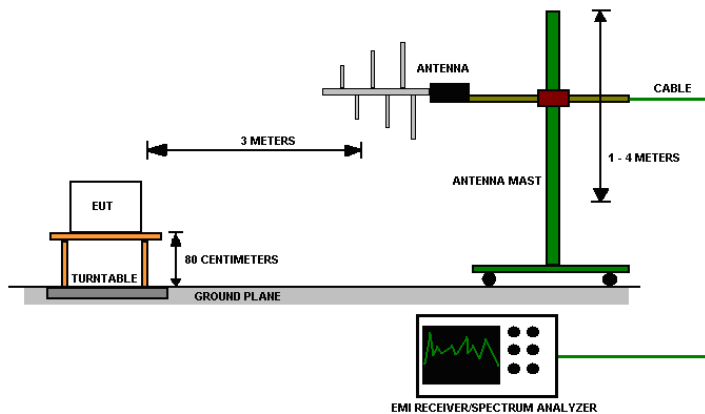

Figure 20 - Radiated Emissions Test Setup



Report Number:	R20190123-20-01	Rev	B
Prepared for:	Garmin		

NOTE:

1. The resolution bandwidth and video bandwidth of test receiver/spectrum analyzer is 120kHz for Peak detection (PK) and Quasi-peak detection (QP) at frequencies below 1GHz.
2. The resolution bandwidth 1 MHz for all measurements and at frequencies above 1GHz, A peak detector was used for all measurements above 1GHz. Measurements were made with an EMI Receiver.

Deviations from test standard:

No deviation.

EUT operating conditions

The EUT was powered by internal battery power unless specified and set to transmit continuously on the lowest frequency channel, highest frequency channel and one in the middle of its operating range. EUT was set to transmit in GMSK and GFSK.

Test results:

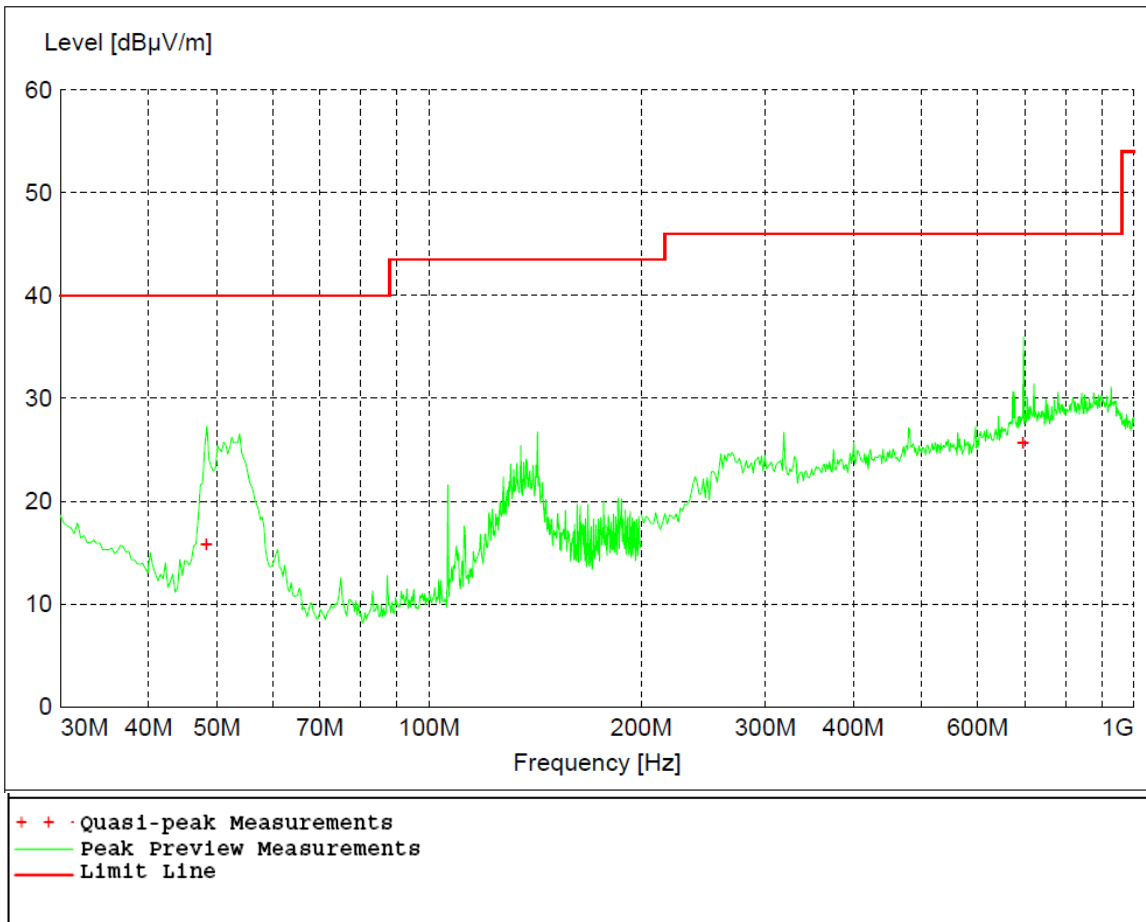

Figure 21 - Radiated Emissions Plot, Receive

REMARKS:

1. Emission level (dBuV/m) = Raw Value (dBuV) + Correction Factor (dB)
2. Correction Factor (dB/m) = Antenna Factor (dB/m) + Cable Factor (dB)
3. The other emission levels were very low against the limit.
4. Margin value = Emission level – Limit value

Table 1 - Radiated Emissions Quasi-peak Measurements, Receive

Frequency	Level	Limit	Margin	Height	Angle	Pol
MHz	dBµV/m	dBµV/m	dB	cm.	deg.	
48.300000	15.87	40.00	24.10	100	174	VERT
696.000000	25.70	46.00	20.30	99	267	VERT

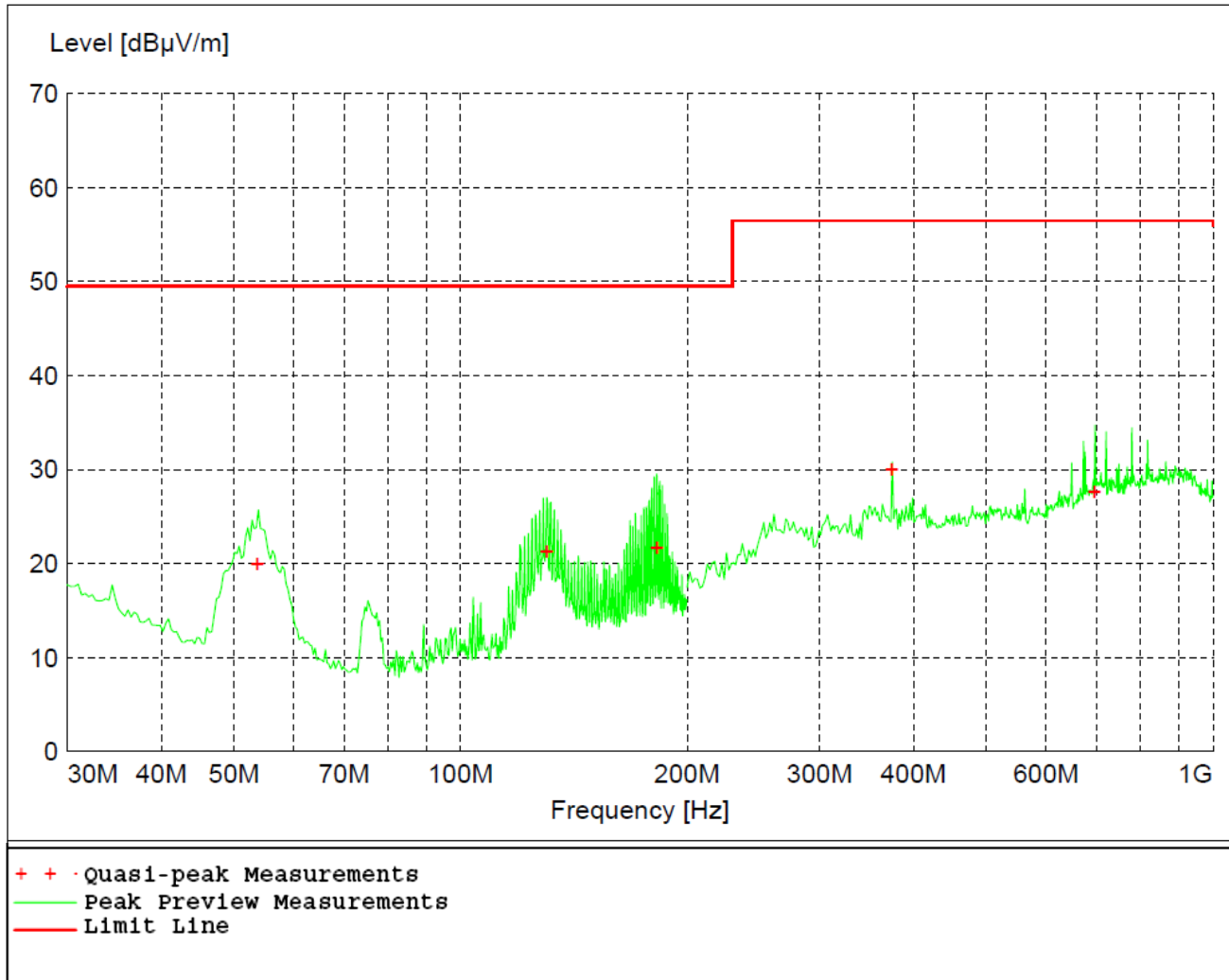

Figure 22 - Radiated Emissions Plot, Low Channel, GMSK

REMARKS:

1. Emission level (dBuV/m) = Raw Value (dBuV) + Correction Factor (dB)
2. Correction Factor (dB/m) = Antenna Factor (dB/m) + Cable Factor (dB)
3. The other emission levels were very low against the limit.
4. Margin value = Emission level – Limit value

Report Number:	R20190123-20-01	Rev	B
Prepared for:	Garmin		

Table 2 - Radiated Emissions Quasi-peak Measurements, Low Channel, GMSK

Frequency	Level	Limit	Margin	Height	Angle	Pol
MHz	dB μ V/m	dB μ V/m	dB	cm.	deg.	
53.700000	19.96	49.50	29.50	100	0	VERT
130.200000	21.34	49.50	28.20	100	295	VERT
182.400000	21.79	49.50	27.70	100	75	VERT
374.400000	30.04	56.50	26.50	99	30	HORI
696.000000	27.64	56.50	28.90	107	262	HORI

The EUT was maximized in all 3 orthogonal axis. The worst-case is shown in the table above.

Table 3 - Radiated Emissions Peak Measurements, Low Channel, GMSK

Frequency	Level	Limit	Margin	Height	Angle	Pol
MHz	dB μ V/m	dB μ V/m	dB	cm.	deg.	
2402.000000	90.93	114.00	23.07	224	322	HORI
4806.400000	41.85	74.00	32.15	255	185	VERT

No signals were detected above system sensitivity

Table 4 - Radiated Emissions Average Measurements, Low Channel, GMSK

Frequency	Level	Limit	Margin	Height	Angle	Pol
MHz	dB μ V/m	dB μ V/m	dB	cm.	deg.	
2402.000000	90.93	N/A	N/A	224	322	HORI
4806.400000	41.85	54.00	12.15	255	185	VERT

No signals were detected above system sensitivity

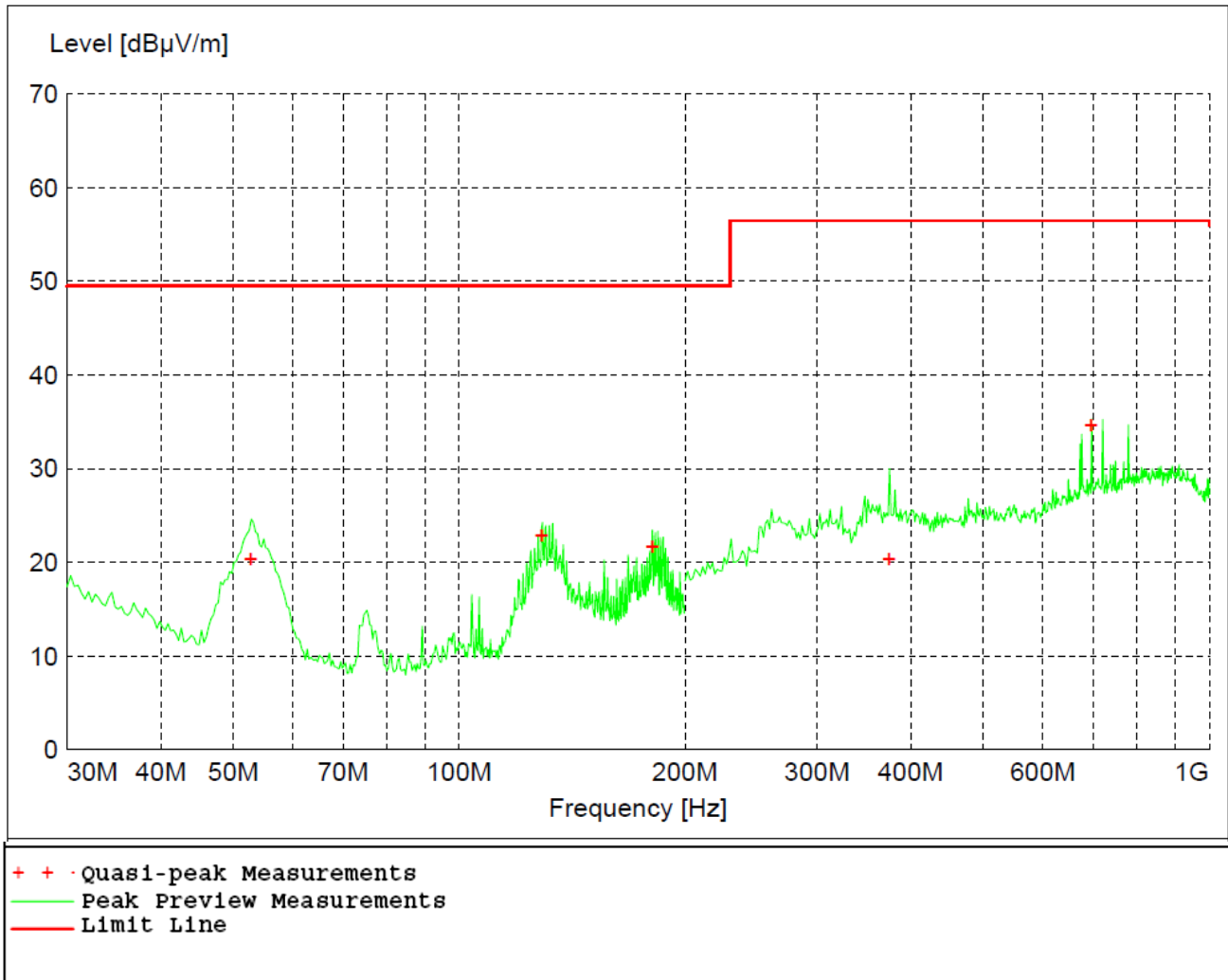

Figure 23 - Radiated Emissions Plot, Mid Channel, GMSK

REMARKS:

1. Emission level (dBuV/m) = Raw Value (dBuV) + Correction Factor (dB)
2. Correction Factor (dB/m) = Antenna Factor (dB/m) + Cable Factor (dB)
3. The other emission levels were very low against the limit.
4. Margin value = Emission level – Limit value

Report Number:	R20190123-20-01	Rev	B
Prepared for:	Garmin		

Table 5 - Radiated Emissions Quasi-peak Measurements, Mid Channel, GMSK

Frequency	Level	Limit	Margin	Height	Angle	Pol
MHz	dB μ V/m	dB μ V/m	dB	cm.	deg.	
52.740000	20.35	49.50	29.10	101	310	VERT
128.820000	22.91	49.50	26.60	99	309	VERT
180.960000	21.71	49.50	27.80	100	65	VERT
374.400000	20.42	56.50	36.10	98	27	HORI
696.000000	34.64	56.50	21.90	102	83	VERT

The EUT was maximized in all 3 orthogonal axis. The worst-case is shown in the table above.

Table 6 - Radiated Emissions Peak Measurements, Mid Channel, GMSK

Frequency	Level	Limit	Margin	Height	Angle	Pol
MHz	dB μ V/m	dB μ V/m	dB	cm.	deg.	
2440.000000	87.42	114.00	26.58	173	55	HORI
4893.600000	45.38	74.00	28.62	356	11	HORI

No signals were detected above system sensitivity

The EUT was maximized in all 3 orthogonal axis. The worst-case is shown in the table above

Table 7 - Radiated Emissions Average Measurements, Mid Channel, GMSK

Frequency	Level	Limit	Margin	Height	Angle	Pol
MHz	dB μ V/m	dB μ V/m	dB	cm.	deg.	
2440.000000	80.81	94.00	13.19	173	55	HORI
4893.600000	45.38	54.00	8.62	356	11	HORI

No signals were detected above system sensitivity

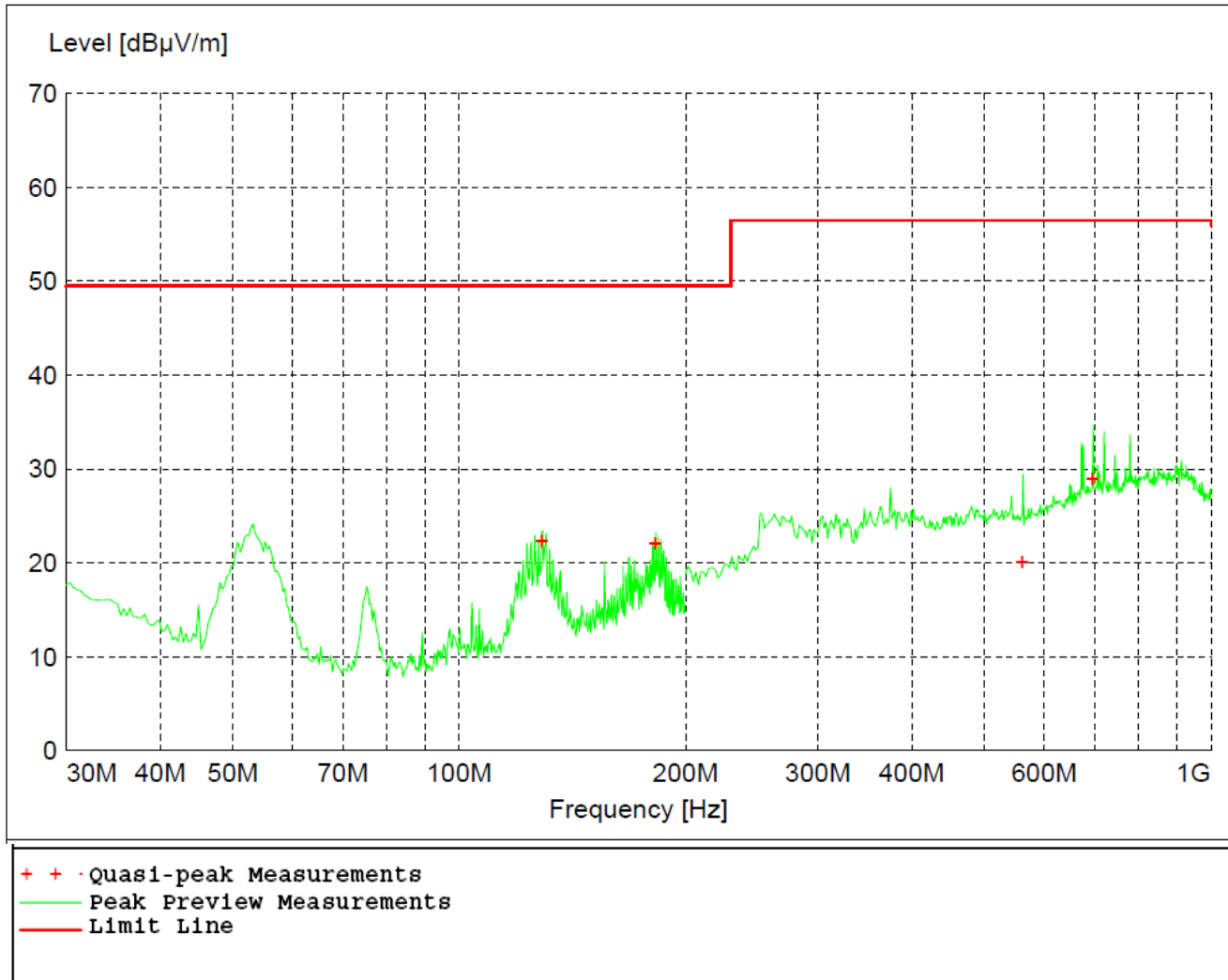

Figure 24 - Radiated Emissions Plot, High Channel, GMSK

REMARKS:

1. Emission level (dBuV/m) = Raw Value (dBuV) + Correction Factor (dB)
2. Correction Factor (dB/m) = Antenna Factor (dB/m) + Cable Factor (dB)
3. The other emission levels were very low against the limit.
4. Margin value = Emission level – Limit value.



Report Number:	R20190123-20-01	Rev	B
Prepared for:	Garmin		

Table 8 - Radiated Emissions Quasi-peak Measurements, High Channel, GMSK

Frequency	Level	Limit	Margin	Height	Angle	Pol
MHz	dBµV/m	dBµV/m	dB	cm.	deg.	
128.820000	22.35	49.50	27.10	99	275	VERT
182.400000	22.13	49.50	27.40	101	84	VERT
561.600000	20.18	56.50	36.30	100	319	VERT
696.000000	28.99	56.50	27.50	109	266	HORI

The EUT was maximized in all 3 orthogonal axis. The worst-case is shown in the table above.

Table 9 - Radiated Emissions Peak Measurements, High Channel, GMSK

Frequency	Level	Limit	Margin	Height	Angle	Pol
MHz	dBµV/m	dBµV/m	dB	cm.	deg.	
2480.000000	95.09	114.00	18.91	177	46	HORI
4816.400000	42.24	74.00	31.76	335	165	VERT
7418.400000	45.34	74.00	28.66	200	0	HORI

No signals were detected above system sensitivity

Table 10 - Radiated Emissions Average Measurements, High Channel, GMSK

Frequency	Level	Limit	Margin	Height	Angle	Pol
MHz	dBµV/m	dBµV/m	dB	cm.	deg.	
2480.000000	89.26	94.00	4.74	177	46	HORI
4816.400000	29.11	54.00	24.89	335	165	VERT
7418.400000	31.77	54.00	22.23	200	0	HORI

No signals were detected above system sensitivity

The EUT was maximized in all 3 orthogonal axis. The worst-case is shown in the table above

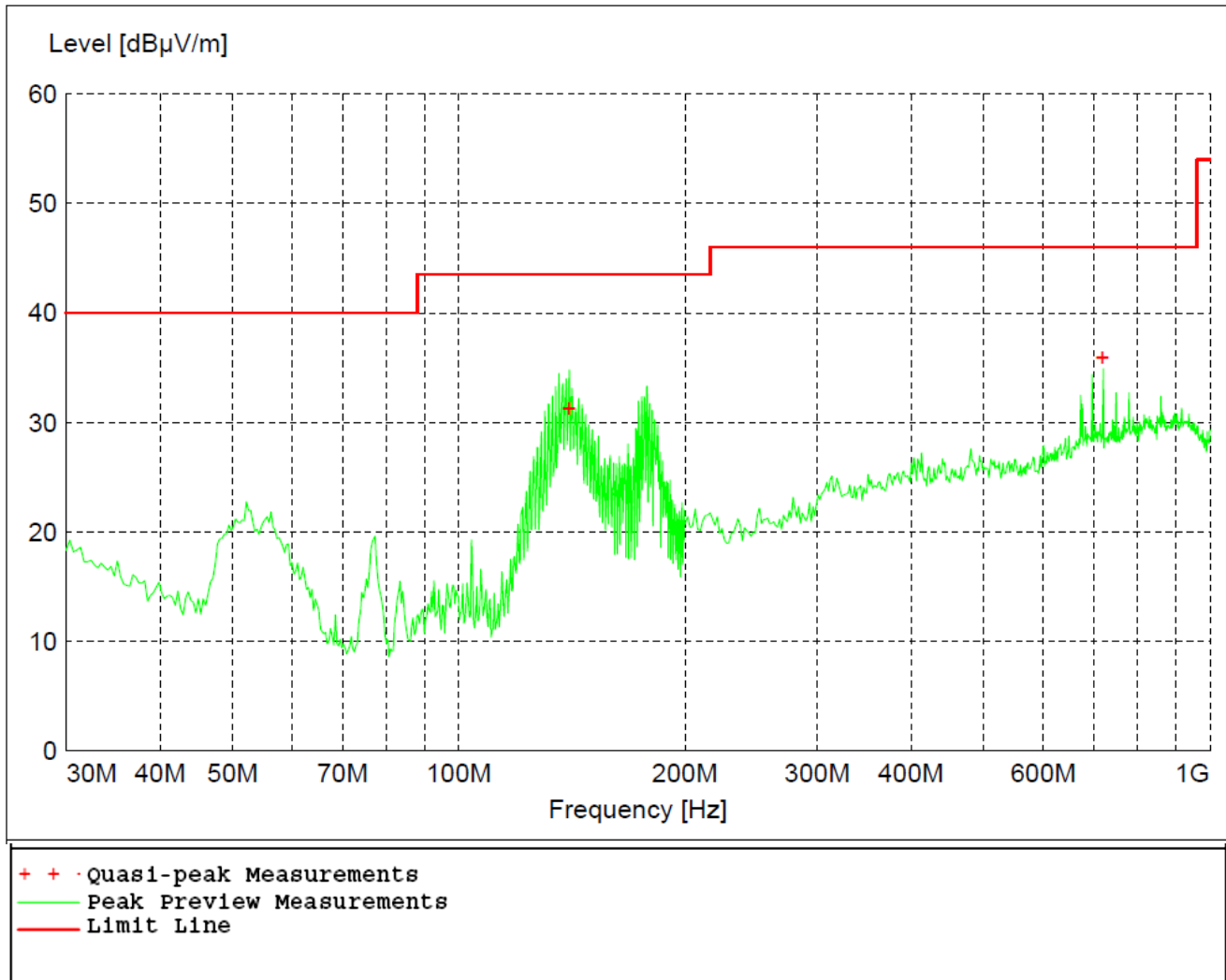

Figure 25 - Radiated Emissions Plot, Low Channel, GFSK

REMARKS:

1. Emission level (dBµV/m) = Raw Value (dBµV) + Correction Factor (dB)
2. Correction Factor (dB/m) = Antenna Factor (dB/m) + Cable Factor (dB)
3. The other emission levels were very low against the limit.
4. Margin value = Emission level – Limit value

Report Number:	R20190123-20-01	Rev	B
Prepared for:	Garmin		

Table 11 - Radiated Emissions Quasi-peak Measurements, Low Channel, GFSK

Frequency	Level	Limit	Margin	Height	Angle	Pol
MHz	dB μ V/m	dB μ V/m	dB	cm.	deg.	
140.340000	31.30	43.50	12.20	100	146	VERT
720.000000	35.91	46.00	10.10	216	216	HORI

The EUT was maximized in all 3 orthogonal axis. The worst-case is shown in the table above.

Table 12 - Radiated Emissions Peak Measurements, Low Channel, GFSK

Frequency	Level	Limit	Margin	Height	Angle	Pol
MHz	dB μ V/m	dB μ V/m	dB	cm.	deg.	
2402.000000	93.78	114.00	20.22	187	130	HORI

No signals were detected above system sensitivity

Table 13 - Radiated Emissions Average Measurements, Low Channel, GFSK

Frequency	Level	Limit	Margin	Height	Angle	Pol
MHz	dB μ V/m	dB μ V/m	dB	cm.	deg.	
2402.000000	82.26	94.00	11.74	187	130	HORI

No signals were detected above system sensitivity

The EUT was maximized in all 3 orthogonal axis. The worst-case is shown in the table above.

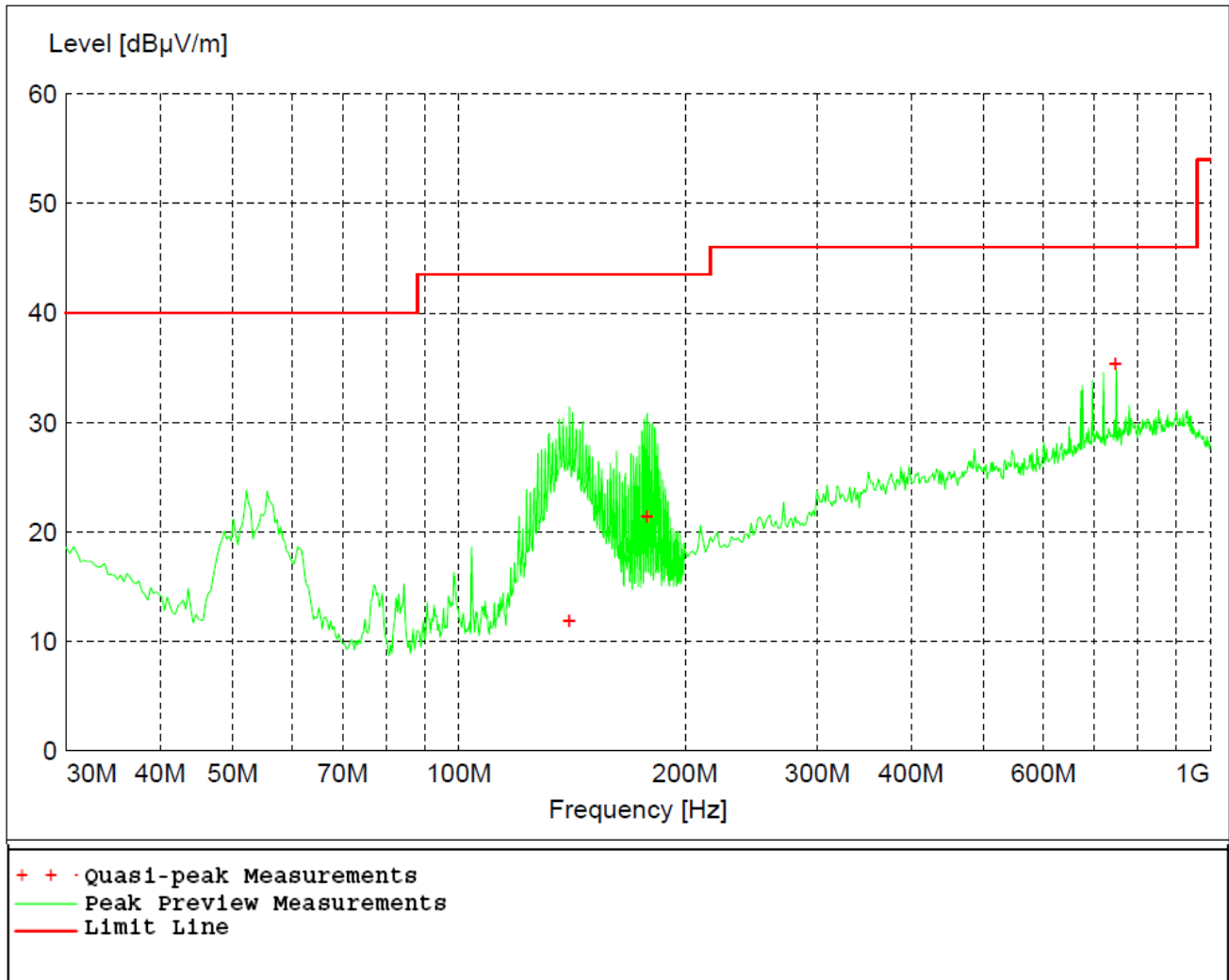

Figure 26 - Radiated Emissions Plot, Mid Channel, GFSK

REMARKS:

1. Emission level (dBuV/m) = Raw Value (dBuV) + Correction Factor (dB)
2. Correction Factor (dB/m) = Antenna Factor (dB/m) + Cable Factor (dB)
3. The other emission levels were very low against the limit.
4. Margin value = Emission level – Limit value

Report Number:	R20190123-20-01	Rev	B
Prepared for:	Garmin		

Table 14 - Radiated Emissions Quasi-peak Measurements, Mid Channel, GFSK

Frequency	Level	Limit	Margin	Height	Angle	Pol
MHz	dB μ V/m	dB μ V/m	dB	cm.	deg.	
140.340000	11.97	43.50	31.50	126	167	VERT
178.080000	21.51	43.50	22.00	100	188	VERT
748.800000	35.37	46.00	10.60	103	28	HORI

The EUT was maximized in all 3 orthogonal axis. The worst-case is shown in the table above.

Table 15 - Radiated Emissions Peak Measurements, Mid Channel, GFSK

Frequency	Level	Limit	Margin	Height	Angle	Pol
MHz	dB μ V/m	dB μ V/m	dB	cm.	deg.	
2440.000000	95.75	114.00	18.25	187	130	HORI

No signals were detected above system sensitivity

Table 16 - Radiated Emissions Average Measurements, Mid Channel, GFSK

Frequency	Level	Limit	Margin	Height	Angle	Pol
MHz	dB μ V/m	dB μ V/m	dB	cm.	deg.	
2441.000000	84.39	94.00	9.61	187	130	HORI

No signals were detected above system sensitivity

The EUT was maximized in all 3 orthogonal axis. The worst-case is shown in the table above.

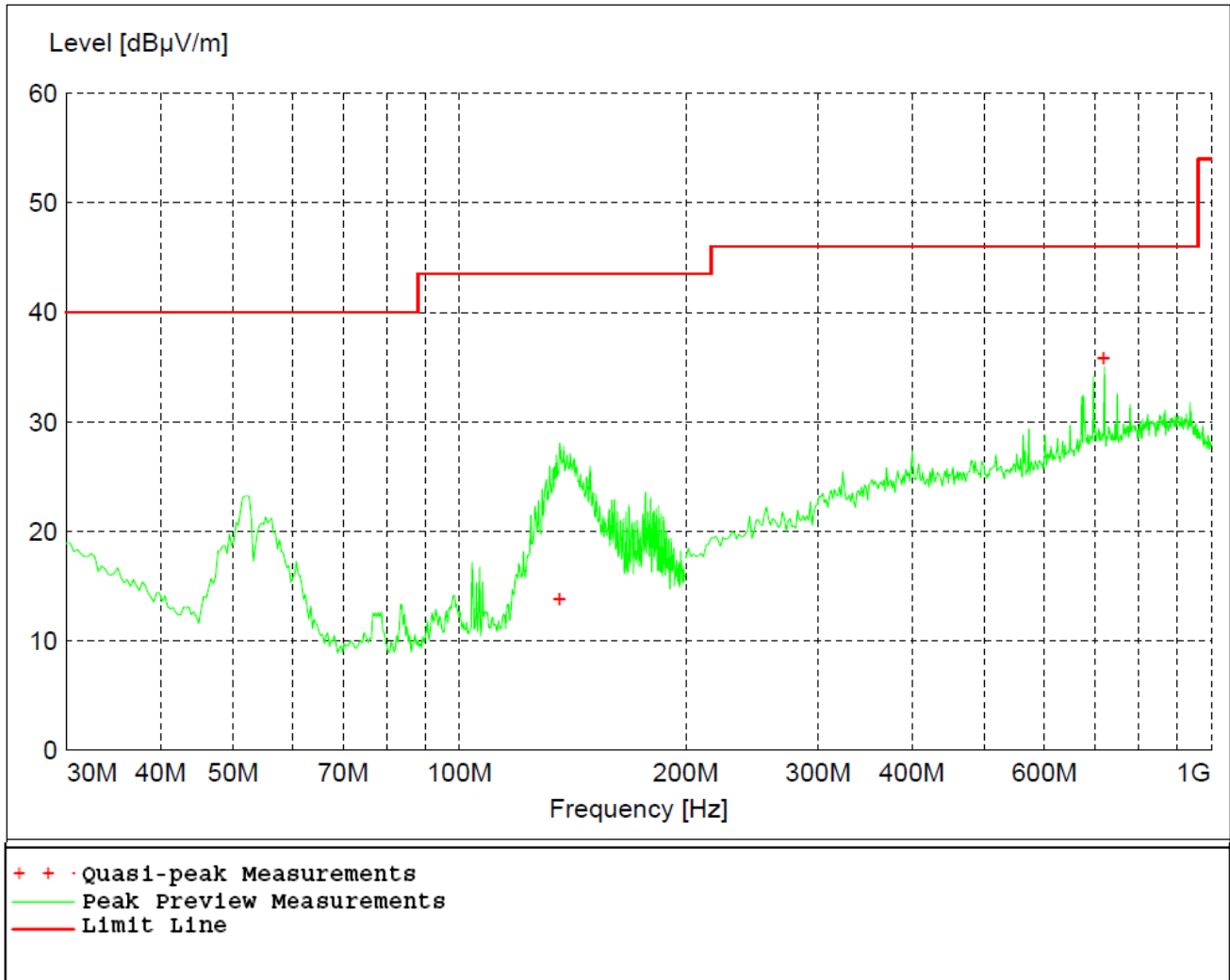

Figure 27 - Radiated Emissions Plot, High Channel, GFSK

REMARKS:

1. Emission level (dBµV/m) = Raw Value (dBµV) + Correction Factor (dB)
2. Correction Factor (dB/m) = Antenna Factor (dB/m) + Cable Factor (dB)
3. The other emission levels were very low against the limit.
4. Margin value = Emission level – Limit value



Report Number:	R20190123-20-01	Rev	B
Prepared for:	Garmin		

Table 17 - Radiated Emissions Quasi-peak Measurements, High Channel, GFSK

Frequency	Level	Limit	Margin	Height	Angle	Pol
MHz	dB μ V/m	dB μ V/m	dB	cm.	deg.	
135.960000	13.89	43.50	29.60	100	148	VERT
720.000000	35.82	46.00	10.20	210	216	HORI

The EUT was maximized in all 3 orthogonal axis. The worst-case is shown in the table above.

Table 18 - Radiated Emissions Peak Measurements, High Channel, GFSK

Frequency	Level	Limit	Margin	Height	Angle	Pol
MHz	dB μ V/m	dB μ V/m	dB	cm.	deg.	
2480.000000	96.13	114.00	17.87	187	130	HORI

No signals were detected above system sensitivity

Table 19 - Radiated Emissions Average Measurements, High Channel, GFSK

Frequency	Level	Limit	Margin	Height	Angle	Pol
MHz	dB μ V/m	dB μ V/m	dB	cm.	deg.	
2480.000000	84.79	94.00	9.21	187	130	HORI

No signals were detected above system sensitivity

The EUT was maximized in all 3 orthogonal axis. The worst-case is shown in the table above.

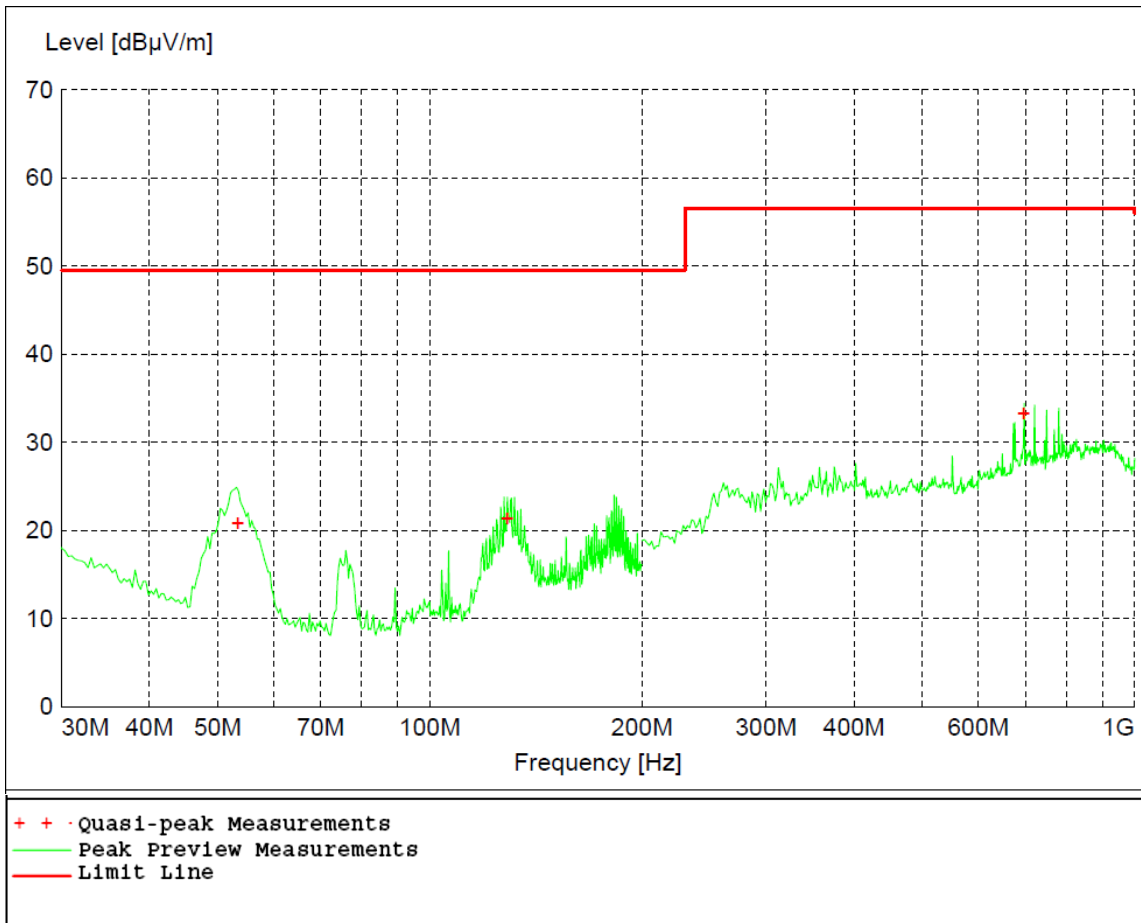

Figure 28 - Radiated Emissions Plot, Low Channel, GFSK (BT BR)

REMARKS:

1. Emission level (dBuV/m) = Raw Value (dBuV) + Correction Factor (dB)
2. Correction Factor (dB/m) = Antenna Factor (dB/m) + Cable Factor (dB)
3. The other emission levels were very low against the limit.
4. Margin value = Emission level – Limit value



Report Number:	R20190123-20-01	Rev	B
Prepared for:	Garmin		

Table 20 - Radiated Emissions Quasi-peak Measurements, Low Channel, GFSK (BT BR)

Frequency	Level	Limit	Margin	Height	Angle	Pol
MHz	dB μ V/m	dB μ V/m	dB	cm.	deg.	
53.400000	20.90	49.50	28.60	100	21	VERT
128.760000	21.42	49.50	28.10	113	319	VERT
696.000000	33.28	56.50	23.20	240	197	VERT

The EUT was maximized in all 3 orthogonal axis. The worst-case is shown in the table above.

Table 21 - Radiated Emissions Peak Measurements, Low Channel, GFSK (BT BR)

Frequency	Level	Limit	Margin	Height	Angle	Pol
MHz	dB μ V/m	dB μ V/m	dB	cm.	deg.	
2402.000000	89.88	114.00	24.12	201	19	HORI
4801.400000	42.35	74.00	31.65	100	300	HORI
7189.600000	47.75	74.00	26.25	265	41	HORI

No signals were detected above system sensitivity

Table 22 - Radiated Emissions Average Measurements, Low Channel, GFSK (BT BR)

Frequency	Level	Limit	Margin	Height	Angle	Pol
MHz	dB μ V/m	dB μ V/m	dB	cm.	deg.	
2402.000000	78.18	94.00	15.82	201	19	HORI
4801.400000	28.68	54.00	25.32	100	300	HORI
7189.600000	33.64	54.00	20.36	265	41	HORI

No signals were detected above system sensitivity

The EUT was maximized in all 3 orthogonal axis. The worst-case is shown in the table above.

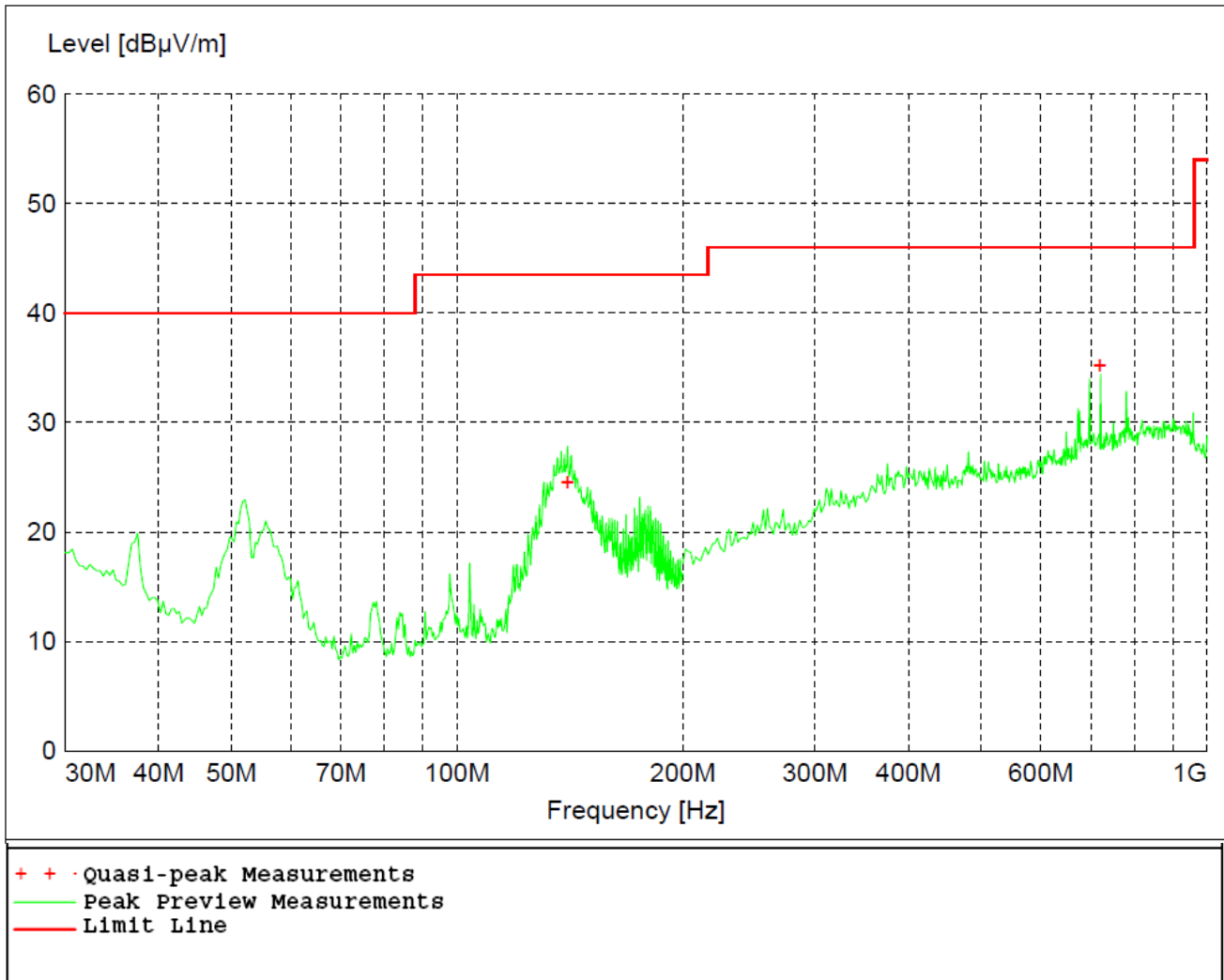

Figure 29 - Radiated Emissions Plot, Mid Channel, GFSK (BT BR)

REMARKS:

1. Emission level (dBuV/m) = Raw Value (dBuV) + Correction Factor (dB)
2. Correction Factor (dB/m) = Antenna Factor (dB/m) + Cable Factor (dB)
3. The other emission levels were very low against the limit.
4. Margin value = Emission level – Limit value

Report Number:	R20190123-20-01	Rev	B
Prepared for:	Garmin		

Table 23 - Radiated Emissions Quasi-peak Measurements, Mid Channel, GFSK (BT BR)

Frequency	Level	Limit	Margin	Height	Angle	Pol
MHz	dB μ V/m	dB μ V/m	dB	cm.	deg.	
140.400000	24.62	43.50	18.90	99	128	VERT
720.000000	35.29	46.00	10.70	216	216	HORI

The EUT was maximized in all 3 orthogonal axis. The worst-case is shown in the table above.

Table 24 - Radiated Emissions Peak Measurements, Mid Channel, GFSK (BT BR)

Frequency	Level	Limit	Margin	Height	Angle	Pol
MHz	dB μ V/m	dB μ V/m	dB	cm.	deg.	
2441.000000	94.50	114.00	19.50	174	236	HORI
4890.000000	44.49	74.00	29.51	167	104	VERT

No signals were detected above system sensitivity

Table 25 - Radiated Emissions Average Measurements, Mid Channel, GFSK (BT BR)

Frequency	Level	Limit	Margin	Height	Angle	Pol
MHz	dB μ V/m	dB μ V/m	dB	cm.	deg.	
2441.000000	83.13	94.00	10.87	174	236	HORI
4890.000000	30.99	54.00	23.01	167	104	VERT

No signals were detected above system sensitivity

The EUT was maximized in all 3 orthogonal axis. The worst-case is shown in the table above.

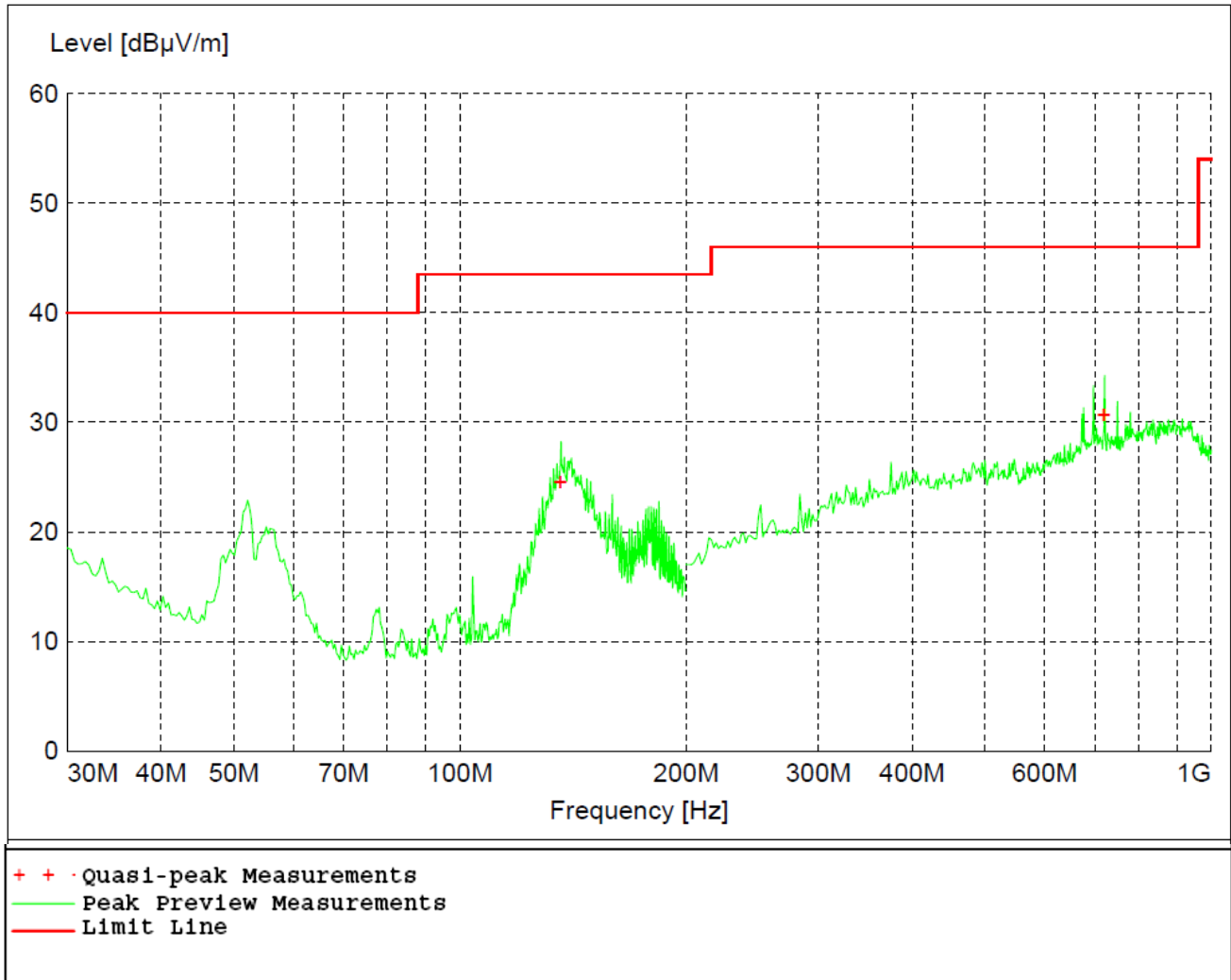

Figure 30 - Radiated Emissions Plot, High Channel, GFSK (BT BR)

REMARKS:

1. Emission level (dBµV/m) = Raw Value (dBµV) + Correction Factor (dB)
2. Correction Factor (dB/m) = Antenna Factor (dB/m) + Cable Factor (dB)
3. The other emission levels were very low against the limit.
4. Margin value = Emission level – Limit value

Report Number:	R20190123-20-01	Rev	B
Prepared for:	Garmin		

Table 26 - Radiated Emissions Quasi-peak Measurements, High Channel, GFSK (BT BR)

Frequency	Level	Limit	Margin	Height	Angle	Pol
MHz	dB μ V/m	dB μ V/m	dB	cm.	deg.	
136.020000	24.62	43.50	18.90	126	186	VERT
720.000000	30.73	46.00	15.30	213	216	HORI

The EUT was maximized in all 3 orthogonal axis. The worst-case is shown in the table above.

Table 27 - Radiated Emissions Peak Measurements, High Channel, GFSK (BT BR)

Frequency	Level	Limit	Margin	Height	Angle	Pol
MHz	dB μ V/m	dB μ V/m	dB	cm.	deg.	
2480.000000	96.17	114.00	17.83	150	45	HORI
4966.600000	42.30	74.00	31.70	382	0	HORI

No signals were detected above system sensitivity

Table 28 - Radiated Emissions Average Measurements, High Channel, GFSK (BT BR)

Frequency	Level	Limit	Margin	Height	Angle	Pol
MHz	dB μ V/m	dB μ V/m	dB	cm.	deg.	
2480.000000	84.73	94.00	9.27	150	45	HORI
4966.600000	28.57	54.00	25.43	382	0	HORI

No signals were detected above system sensitivity

The EUT was maximized in all 3 orthogonal axis. The worst-case is shown in the table above.



Report Number:	R20190123-20-01	Rev	B
Prepared for:	Garmin		

4.5 BAND EDGES

Test Method: ANSI C63.10-2013, Section(s) 6.10.5

Limits of bandedge measurements:

For emissions outside of the allowed band of operation, the field strength levels need to be under that of the limits in 15.209.

Test procedures:

Measurements were performed by connecting the output of the transmitter directly into a spectrum analyzer using an impedance matched cable and connector soldered to the EUT in place of the antenna. The resolution bandwidth was set to 100kHz and the EMI receiver was used to scan from the bandedge to the fundamental frequency with a peak detector. The highest emissions level beyond the bandedge was measured and recorded. All band edge measurements were evaluated to the general limits in Part 15.209.

To calculate the level at the bandedge frequencies, the difference between the peak and the band edge level was subtracted from the peak radiated value at the fundamental. This value was compared to the 15.209 radiated limits for compliance.

Deviations from test standard:

No deviation.

Test setup:

The field strength was measured by connecting the EUT directly to the spectrum analyzer.

EUT operating conditions:

The EUT was powered by internal battery power unless specified and set to transmit continuously on the lowest frequency channel, highest frequency channel and one in the middle of its operating range. EUT was set to transmit in GMSK and GFSK.



Report Number:	R20190123-20-01	Rev	B
Prepared for:	Garmin		

Test results:

CHANNEL	Mode	Band edge /Measurement Frequency (MHz)	Relative Highest out of band level dBm	Relative Fundamental dBm	Delta (dB)	Min Delta (dB)	Result
Low, Continuous,	GFSK	2400	-52.84	-1.32	51.52	28.26	PASS
Low, Continuous,	GMSK	2400	-53.03	-3.14	49.89	30.69	PASS
Low, Continuous,	GFSK (BTBR)	2400	-52.08	-1.22	50.86	24.18	PASS
High, Continuous,	GFSK	2483.5	-56.17	0.56	56.73	30.79	PASS
High, Continuous,	GMSK	2483.5	-55.02	0.04	55.06	35.26	PASS
High, Continuous,	GFSK (BTBR)	2483.5	-55.83	0.78	56.61	30.73	PASS

*Minimum delta = [highest fundamental field strength from Section 4.2] – [Part 15.209 radiated emissions limit.]

	Report Number:	R20190123-20-01	Rev	B
	Prepared for:	Garmin		

From Section 4.2:

Fundamental field strength at Low Channel GFSK = 82.26 dB μ V/m
 Fundamental field strength at High Channel GFSK = 84.79 dB μ V/m
 Fundamental field strength at Low Channel GMSK = 84.69 dB μ V/m
 Fundamental field strength at High Channel GMSK = 89.26 dB μ V/m
 Fundamental field strength at Low Channel GFSK (BT BR) = 78.18 dB μ V/m
 Fundamental field strength at High Channel GFSK (BT BR) = 84.73 dB μ V/m

Minimum delta based on 15.249 limits:

Low Channel minimum delta GFSK = 82.26 – 54.0 dB μ V/m = 28.26 dBc
 High Channel minimum delta GFSK = 84.79 – 54.0 dB μ V/m = 30.79 dBc
 Low Channel minimum delta GMSK = 84.69 – 54.0 dB μ V/m = 30.69 dBc
 High Channel minimum delta GMSK = 89.26 – 54.0 dB μ V/m = 35.26 dBc
 Low Channel minimum delta GFSK (BT BR) = 78.18 – 54.0 dB μ V/m = 24.18 dBc
 High Channel minimum delta GFSK (BT BR) = 84.73 – 54.0 dB μ V/m = 30.73 dBc

FCC Part 15.249 requires the attenuation of all emissions outside of the specified band to be at least 50 dB or below the 15.209 limits, whichever is the lesser. In this case, the 15.209 limits were the lesser and used to show compliance.

The highest fundamental field strength is 89.26 dB μ V/m. At these frequencies, the limits from 15.209 is 54.00 dB μ V/m. So it is sufficient to show compliance with the 15.209 limits instead of the requirement to be 50 dB below.



Marker 1 [T1] RBW 100 kHz RF Att 30 dB
 Ref Lvl -1.32 dBm VBW 300 kHz
 20 dBm 2.40217435 GHz SWT 5.5 ms Unit dBm

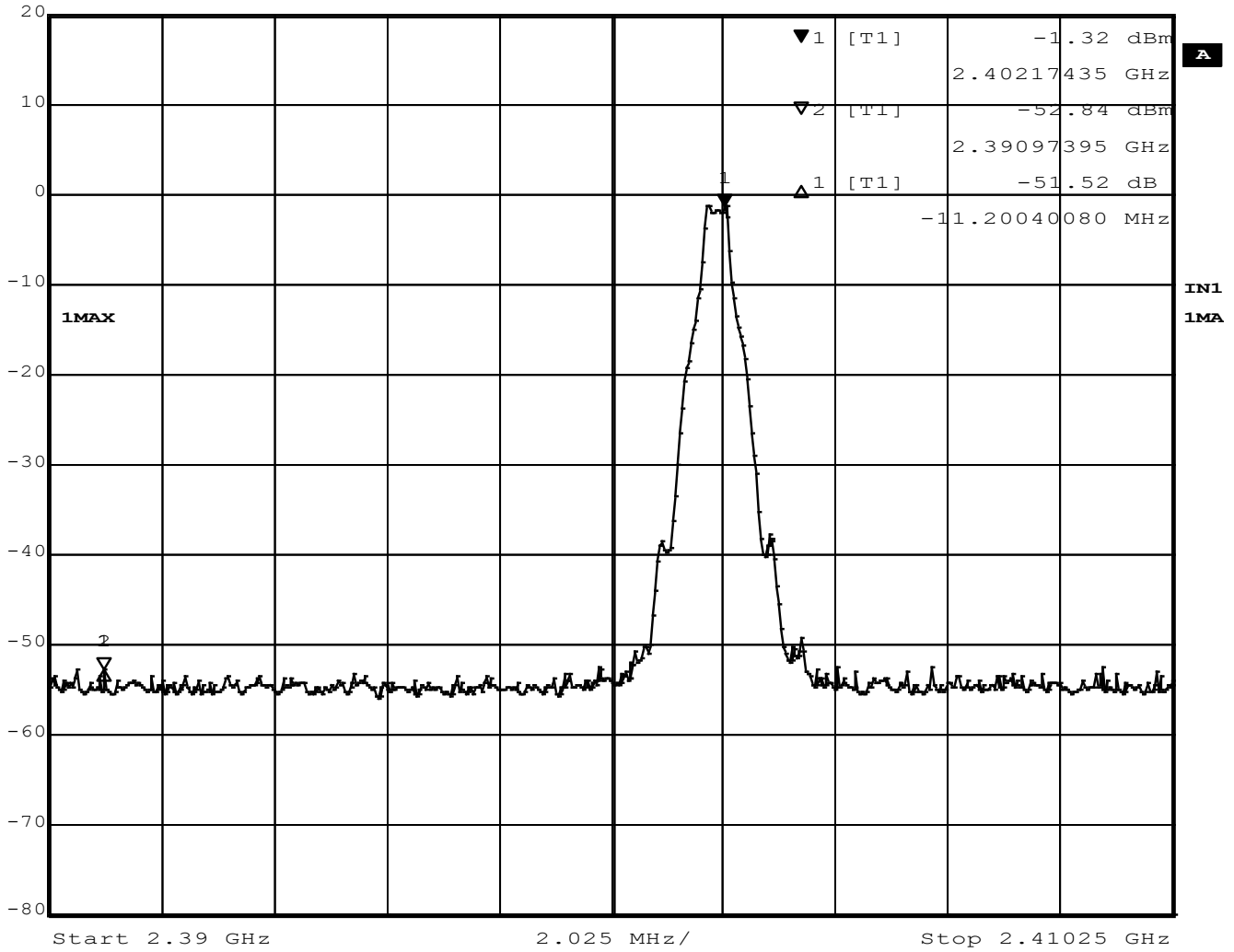

Figure 31 - Band Edge, Low Channel, Unrestricted, GFSK



Marker 1 [T1] RBW 100 kHz RF Att 30 dB
 Ref Lvl 0.56 dBm VBW 300 kHz
 20 dBm 2.47984967 GHz SWT 5 ms Unit dBm

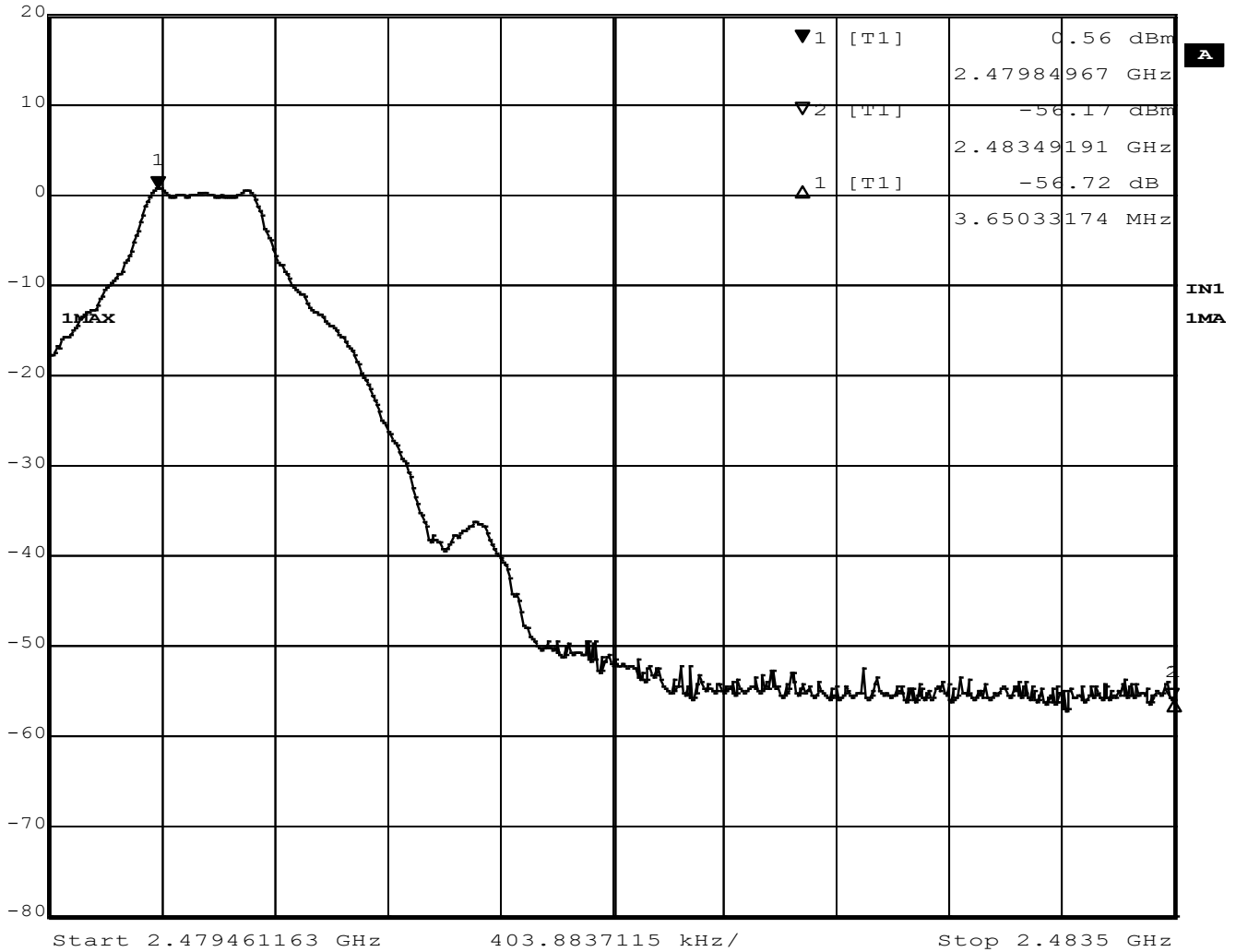

Figure 32 –Band Edge Measurement, High Channel, Unrestricted, GFSK



Marker 1 [T1] RBW 100 kHz RF Att 30 dB

Ref Lvl -3.14 dBm VBW 300 kHz
 20 dBm 2.40230469 GHz SWT 5 ms Unit dBm

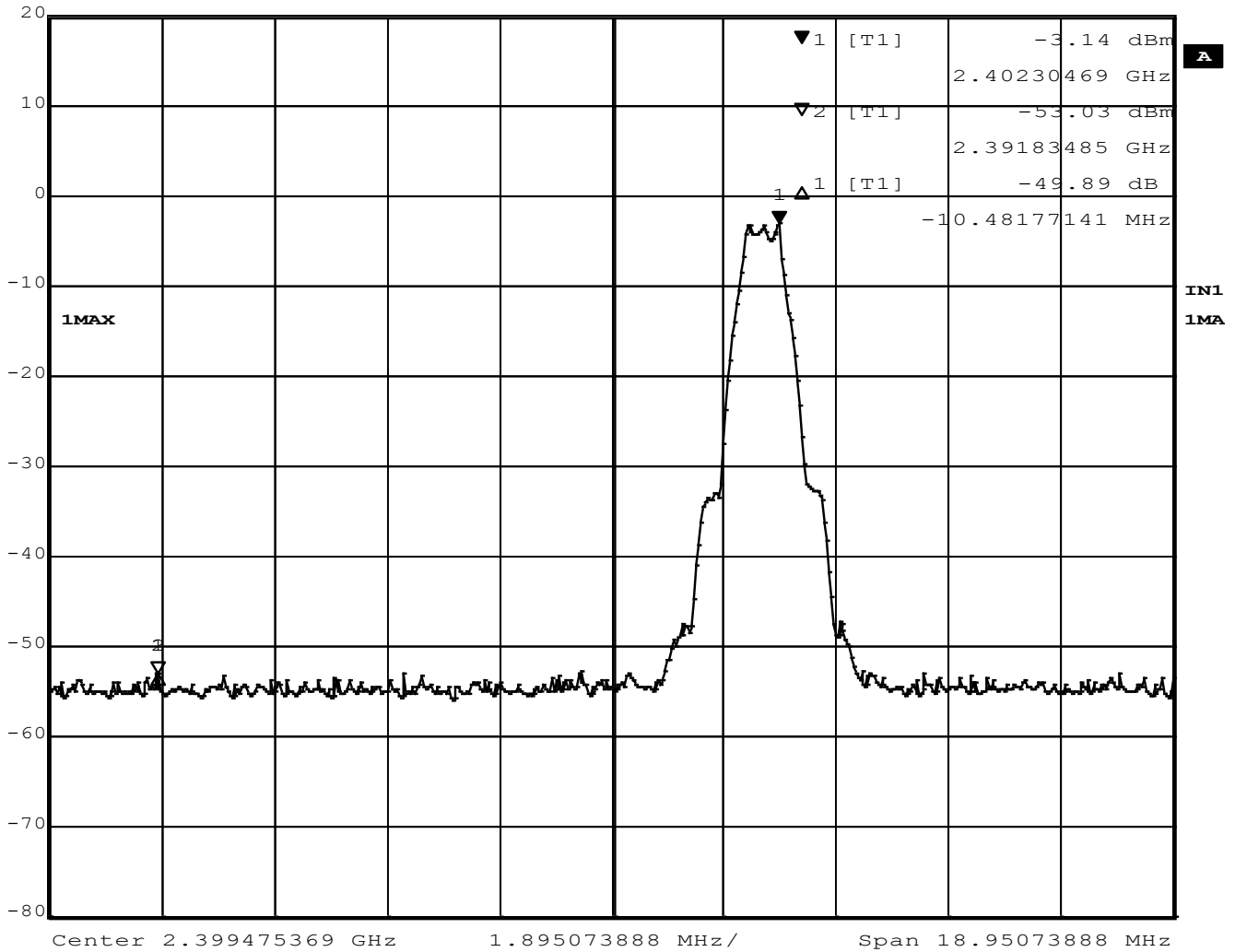

Figure 33 –Band Edge, Low Channel, Unrestricted, GMSK



Marker 1 [T1] RBW 100 kHz RF Att 30 dB
 Ref Lvl 0.04 dBm VBW 300 kHz
 20 dBm 2.48025217 GHz SWT 5 ms Unit dBm

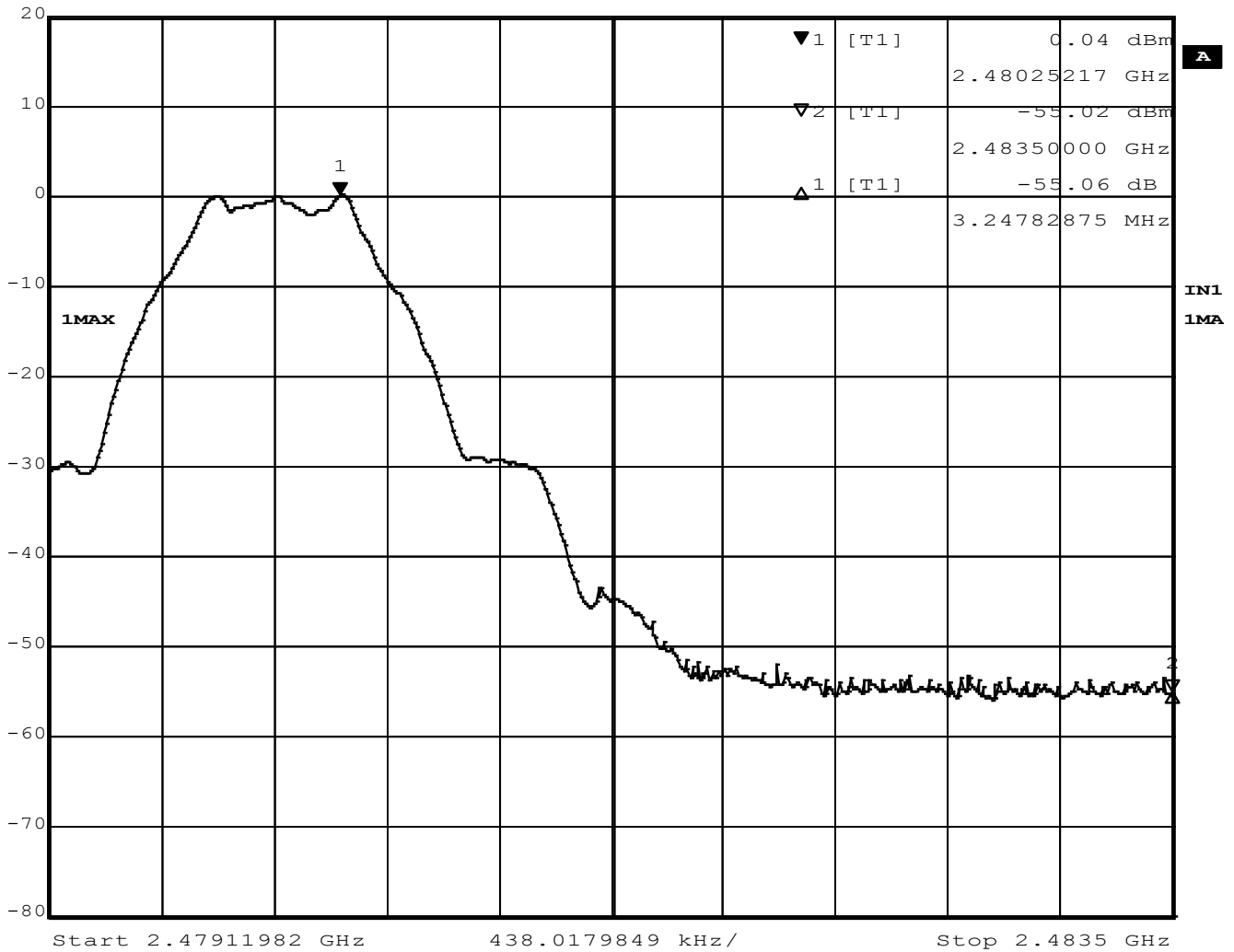

Figure 34 – Band Edge Measurement, High Channel, Unrestricted, GMSK



Marker 1 [T1] RBW 100 kHz RF Att 30 dB
 Ref Lvl -1.22 dBm VBW 300 kHz
 20 dBm 2.40220289 GHz SWT 5 ms Unit dBm

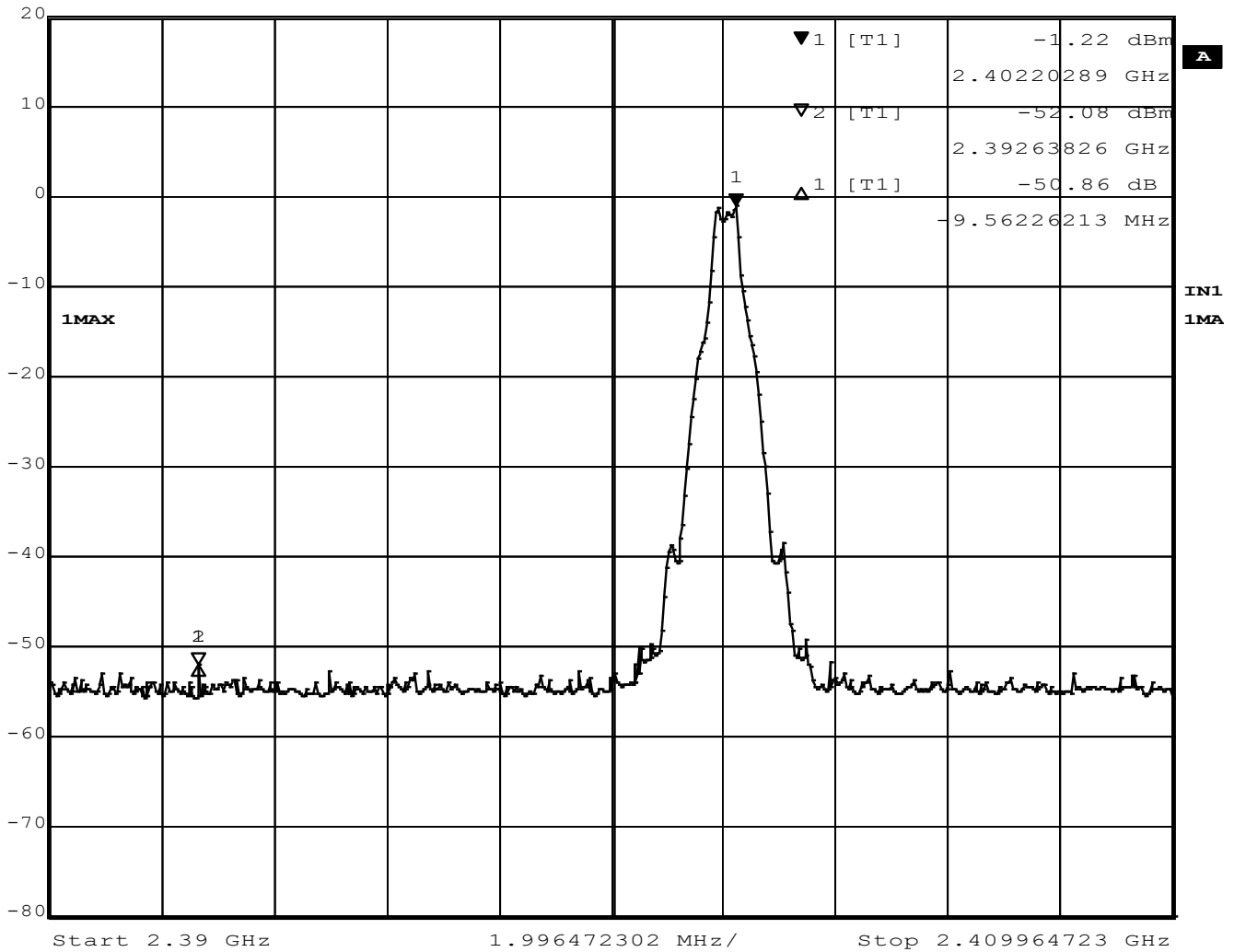

Figure 35 - Band Edge, Low Channel, Unrestricted, GFSK (BT BR)



Marker 1 [T1] RBW 100 kHz RF Att 30 dB
 Ref Lvl 0.78 dBm VBW 300 kHz
 20 dBm 2.48016717 GHz SWT 5 ms Unit dBm

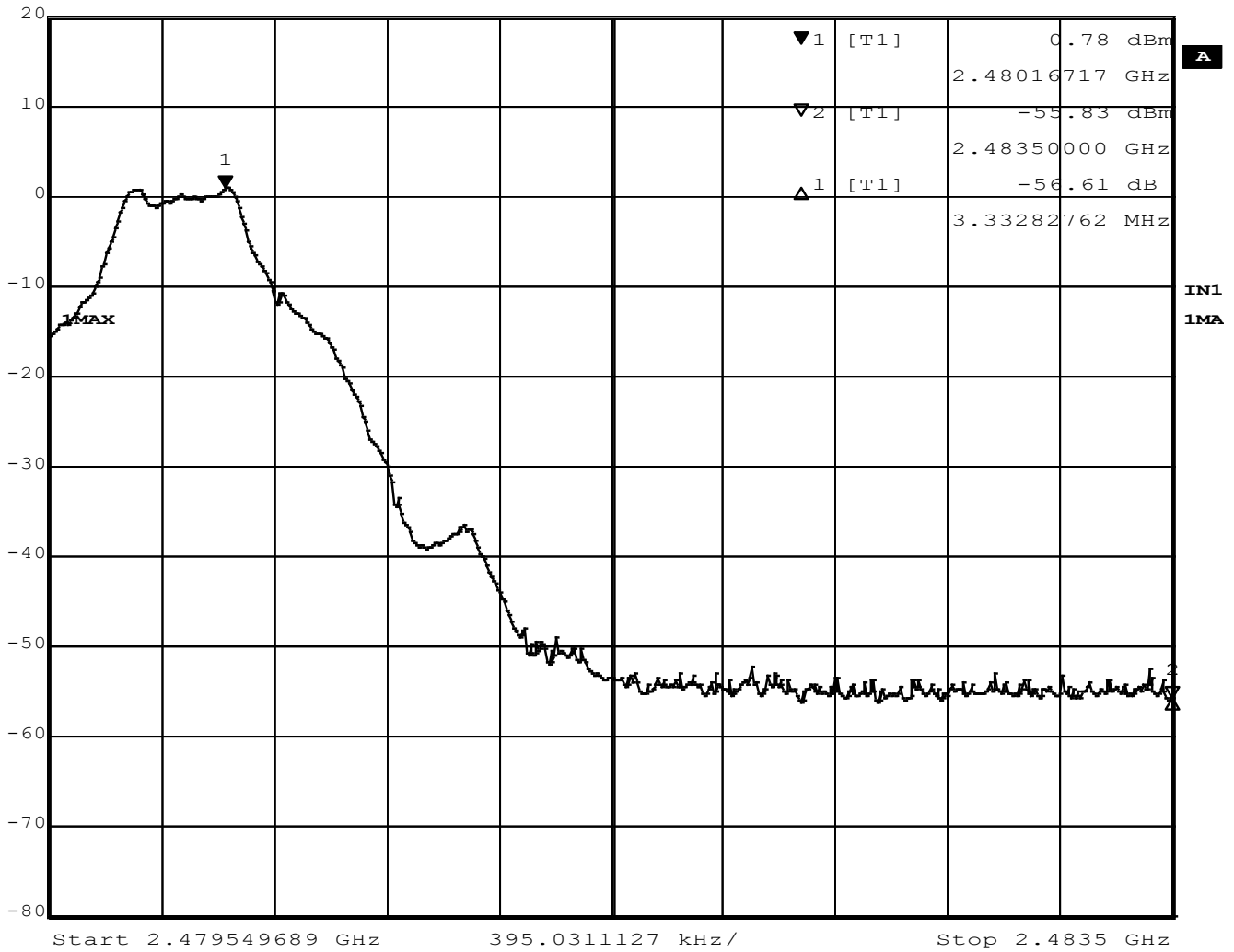

Figure 36 –Band Edge Measurement, High Channel, Unrestricted, GFSK (BT BR)



Marker 1 [T1] RBW 100 kHz RF Att 30 dB
 -53.03 dBm VBW 300 kHz
 Ref Lvl 20 dBm 2.38665331 GHz SWT 5 ms Unit dBm

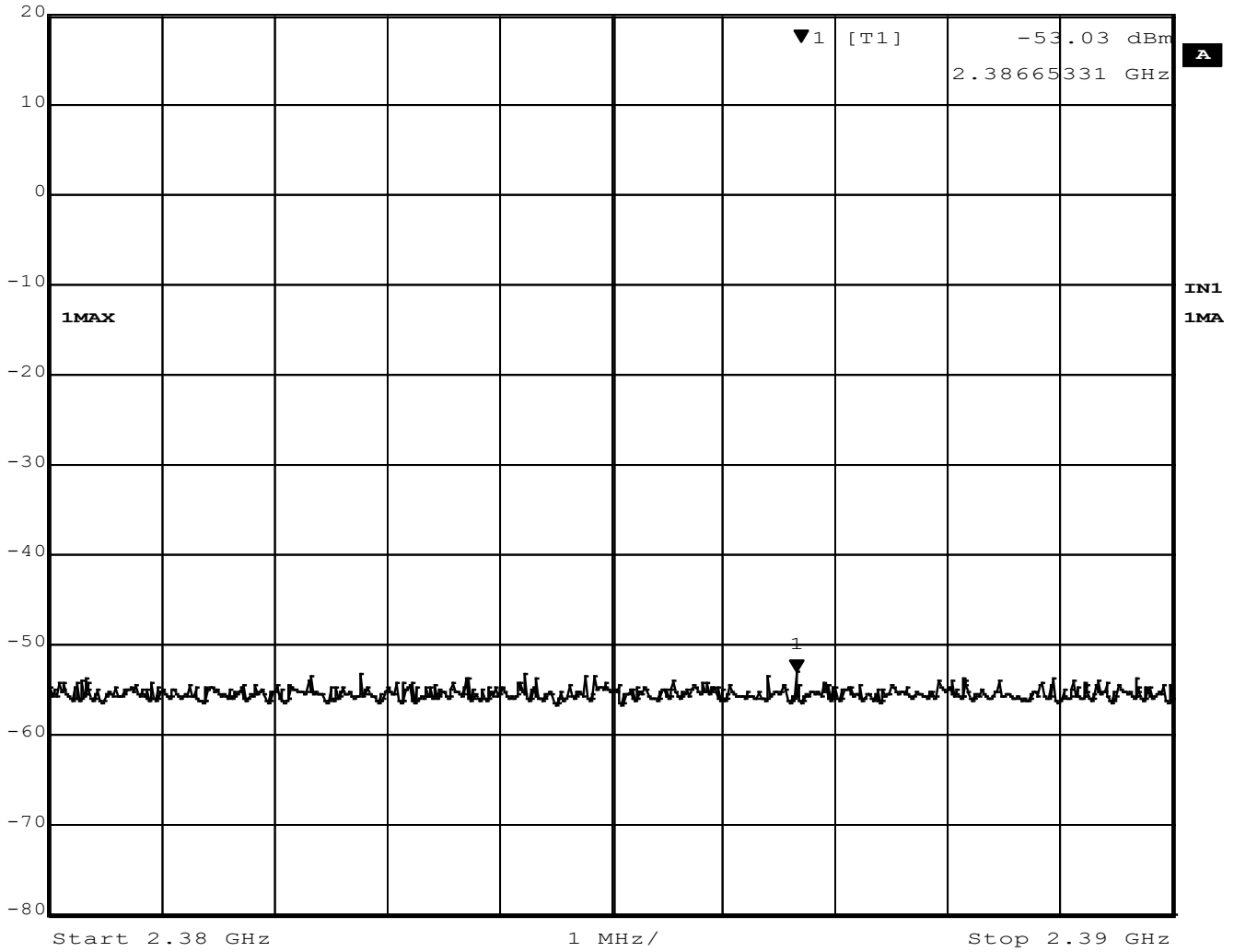

Figure 37 - Band Edge, Low Channel, Restricted, GFSK



Marker 1 [T1] RBW 100 kHz RF Att 30 dB
 Ref Lvl -53.52 dBm VBW 300 kHz
 20 dBm 2.49107214 GHz SWT 5 ms Unit dBm

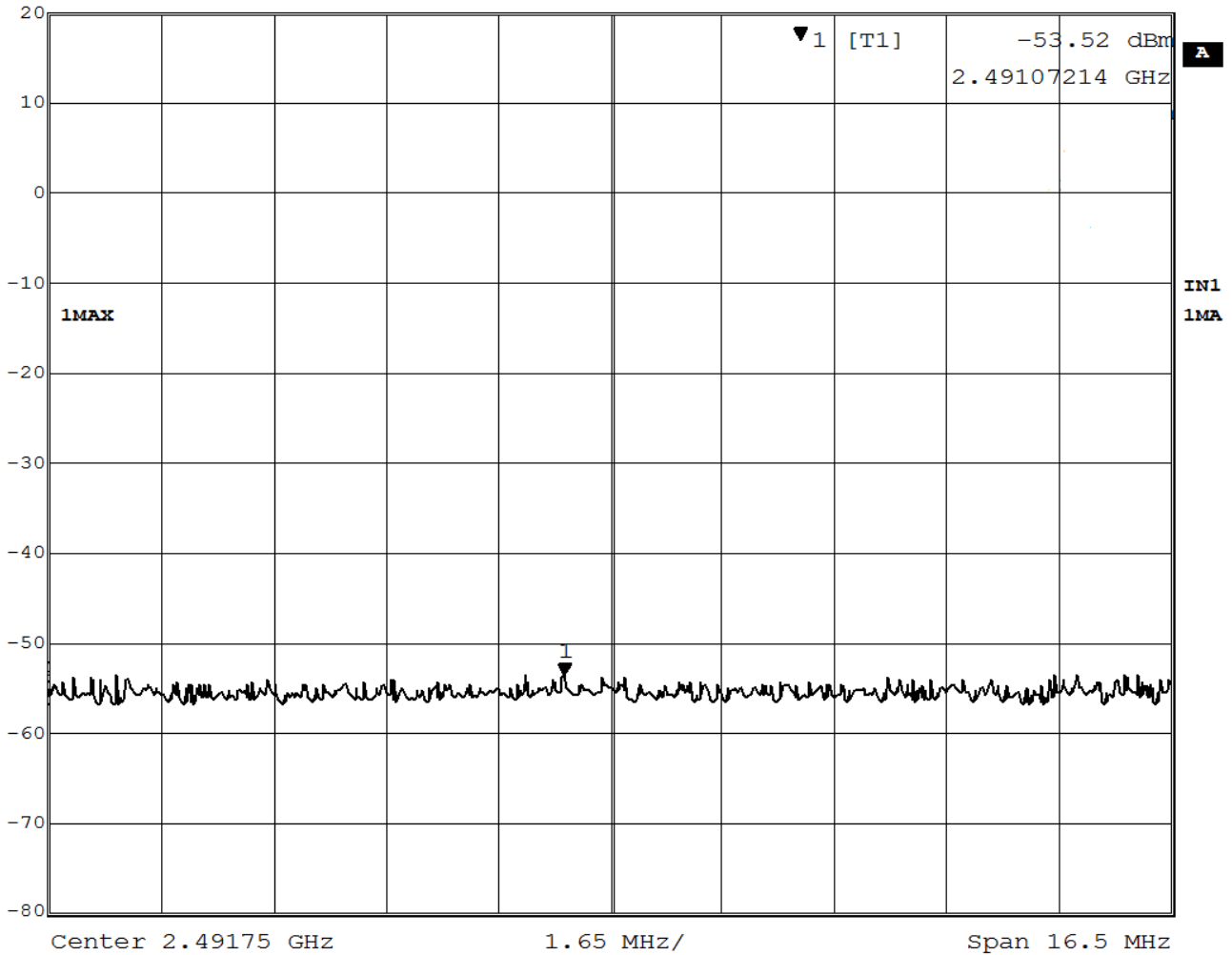

Figure 38 –Band Edge Measurement, High Channel, Restricted, GFSK



Marker 1 [T1] RBW 100 kHz RF Att 30 dB
 Ref Lvl -53.22 dBm VBW 300 kHz
 20 dBm 2.38777555 GHz SWT 5 ms Unit dBm

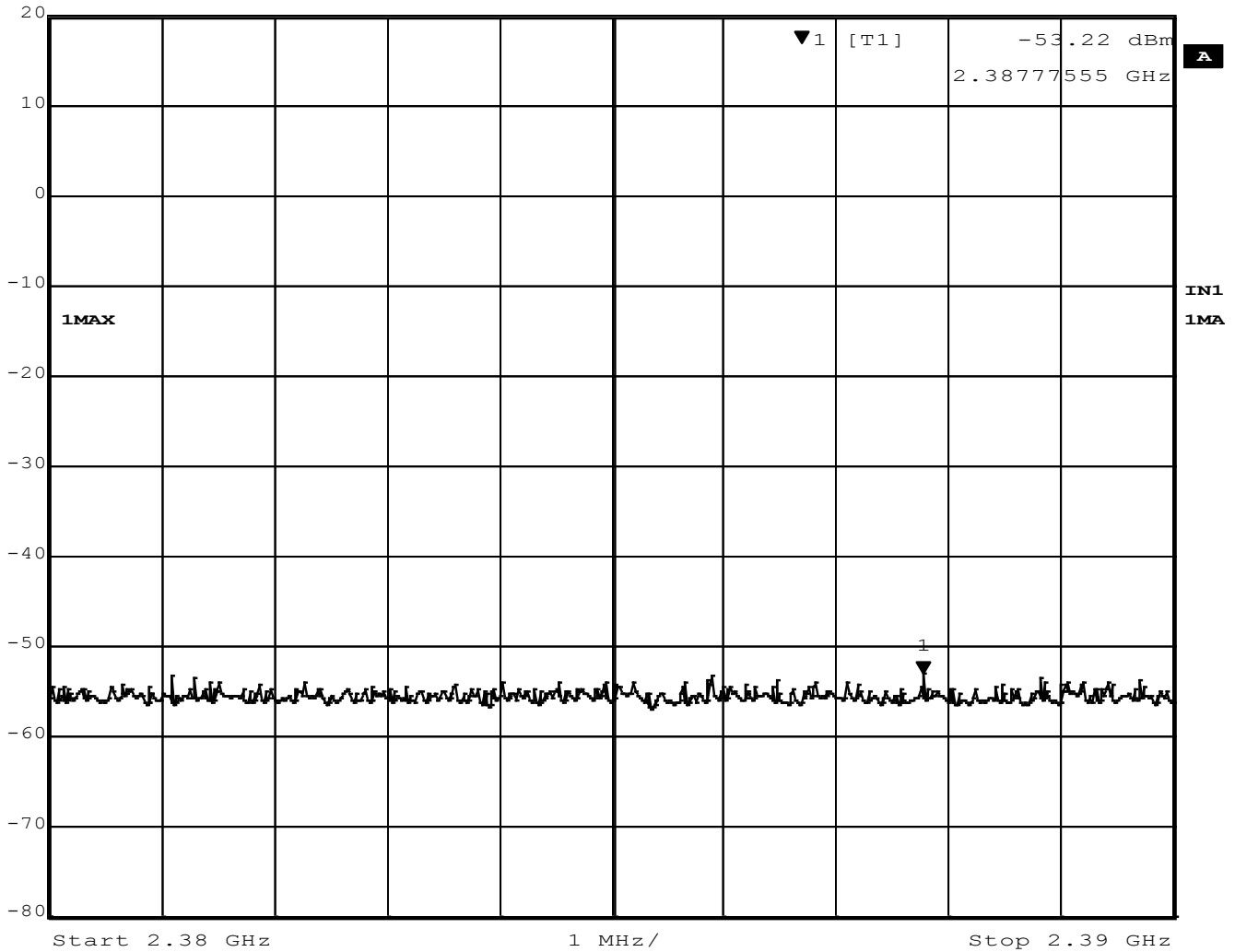

Figure 39 –Band Edge, Low Channel, Restricted, GMSK



Marker 1 [T1] RBW 100 kHz RF Att 30 dB
 -52.79 dBm VBW 300 kHz
 Ref Lvl 20 dBm 2.49484168 GHz SWT 5 ms Unit dBm

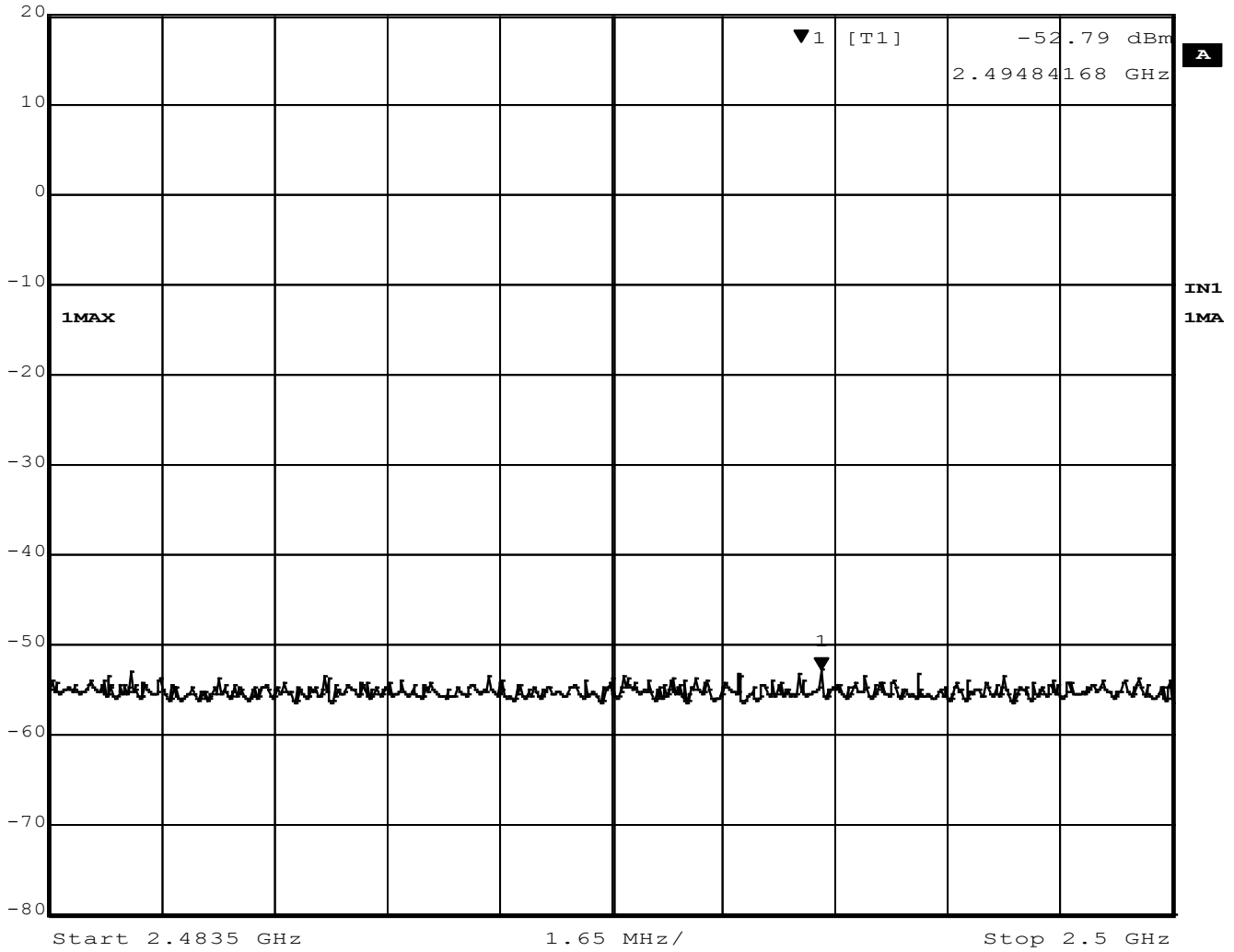

Figure 40 – Band Edge Measurement, High Channel, Restricted, GMSK



Marker 1 [T1] RBW 100 kHz RF Att 30 dB
 -53.30 dBm VBW 300 kHz
 Ref Lvl 20 dBm 2.38248497 GHz SWT 5 ms Unit dBm

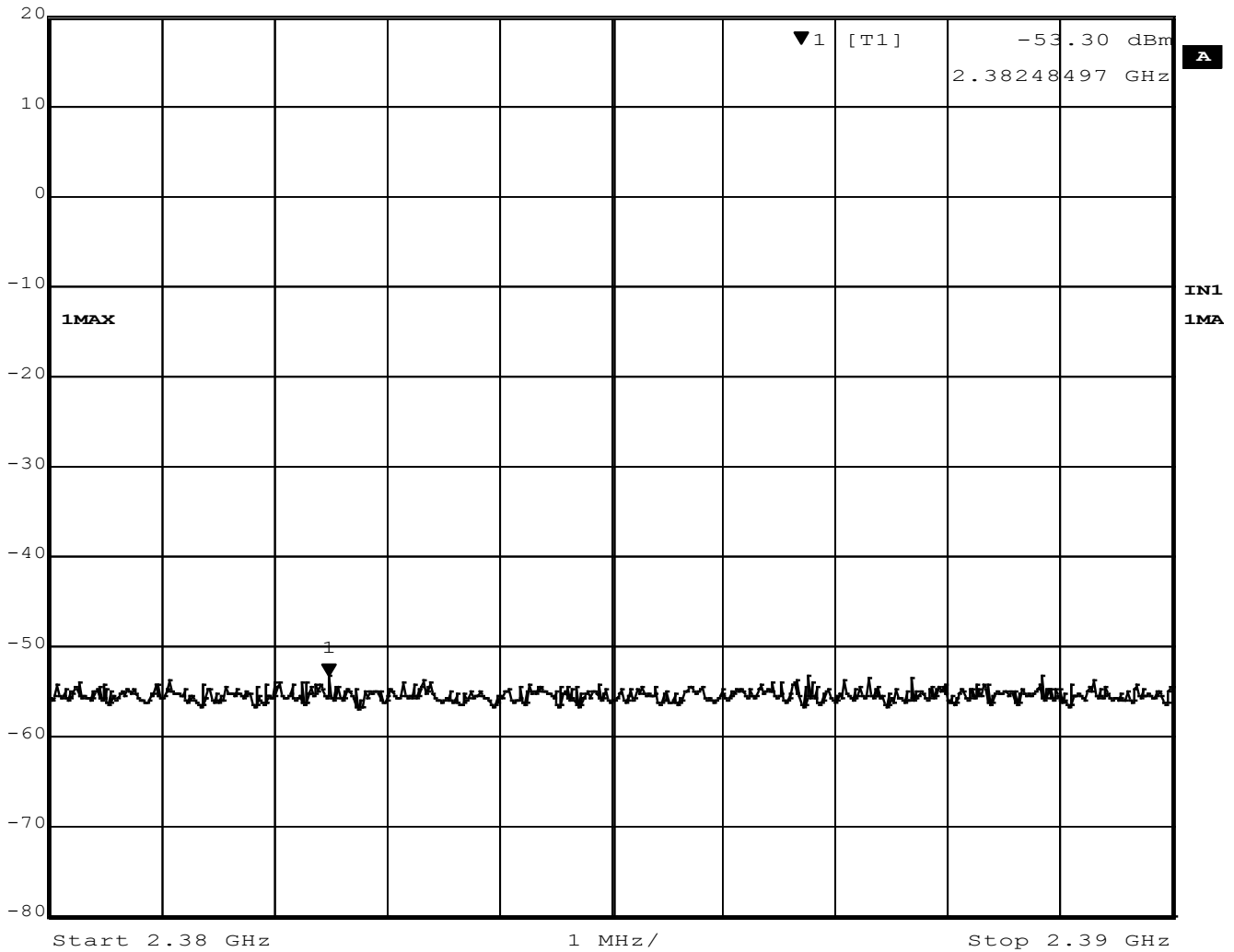

Figure 41 - Band Edge, Low Channel, Restricted, GFSK (BT BR)



Marker 1 [T1] RBW 100 kHz RF Att 30 dB
 Ref Lvl -52.77 dBm VBW 300 kHz
 20 dBm 2.49229559 GHz SWT 5 ms Unit dBm

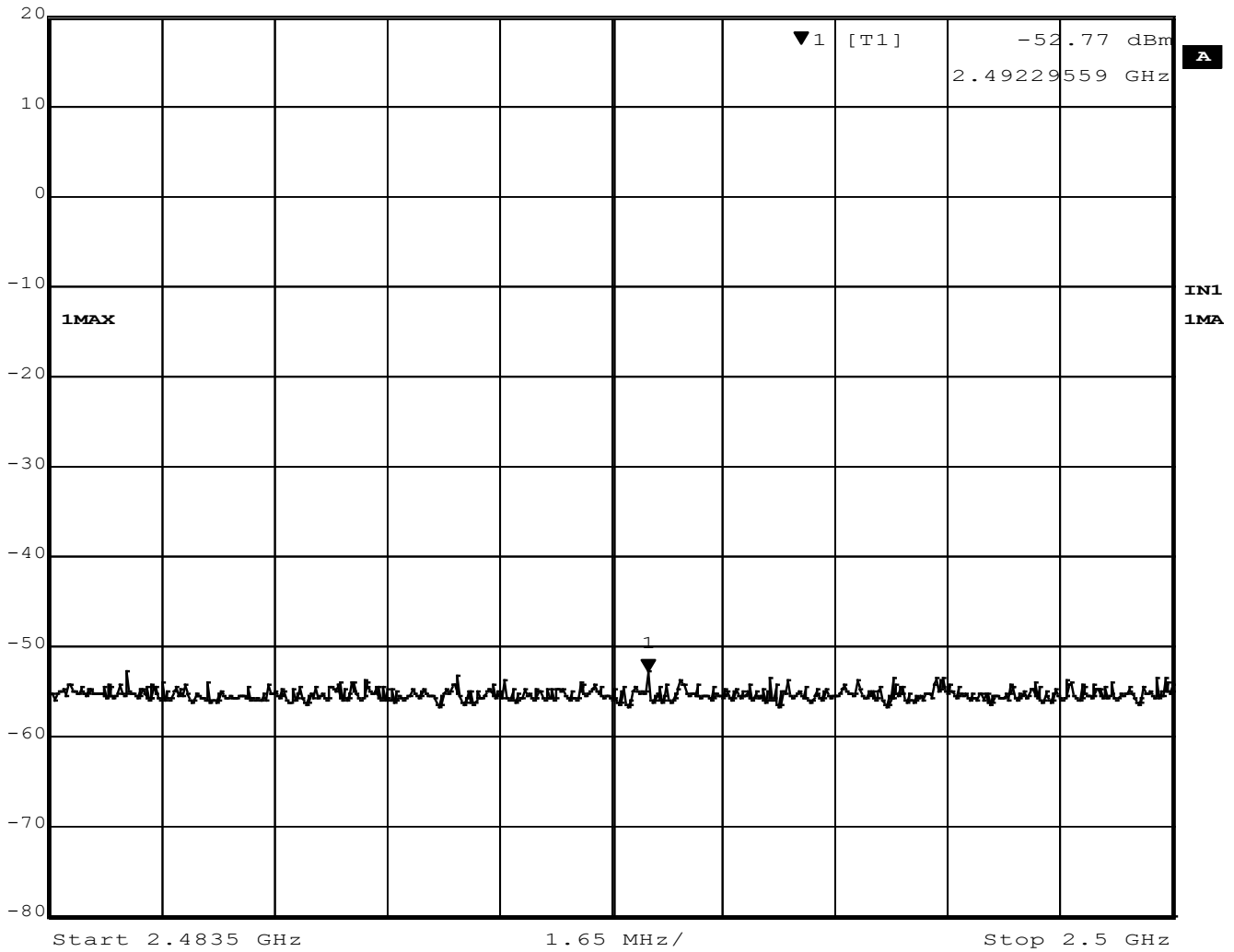

Figure 42 –Band Edge Measurement, High Channel, Restricted, GFSK (BT BR)



Report Number:	R20190123-20-01	Rev	B
Prepared for:	Garmin		

4.6 CONDUCTED AC MAINS EMISSIONS

Test Method: ANSI C63.10-2013, Section(s) 6.2

Limits for conducted emissions measurements:

FREQUENCY OF EMISSION (MHz)	CONDUCTED LIMIT (dB μ V)	
	Quasi-peak	Average
0.15-0.5	66 to 56	56 to 46
0.5-5	56	46
5-30	60	50

Notes:

1. The lower limit shall apply at the transition frequencies.
2. The limit decreases in line with the logarithm of the frequency in the range of 0.15 to 0.50 MHz
3. All emanations from a class A/B digital device or system, including any network of conductors and apparatus connected thereto, shall not exceed the level of field strengths specified above.

Test Procedures:

- a. The EUT was placed 0.8m above a ground reference plane and 0.4 meters from the conducting wall of a shielded room with EUT being connected to the power mains through a line impedance stabilization network (LISN). The LISN provides 50 ohm/ 50uH of coupling impedance for the measuring instrument.
- b. Both lines of the power mains connected to the EUT were checked for maximum conducted interference as well as the ground.
- c. The frequency range from 150 kHz to 30 MHz was searched. Emission levels over 10dB under the prescribed limits are not reported.
- d. Results were compared to the 15.207 limits.

Deviation from the test standard:

No deviation

EUT operating conditions:

The EUT was powered by 5 VDC unless specified and set to transmit continuously on the middle channel.

Test Results:



Att 10 dB AUTO	Marker 1 [T1]	Det	AV Trd	ES-K1
INPUT 2	35.63 dBV	ResBW	9 kHz	
	13.9200000 MHz	Meas T	100 ms Unit	dBV

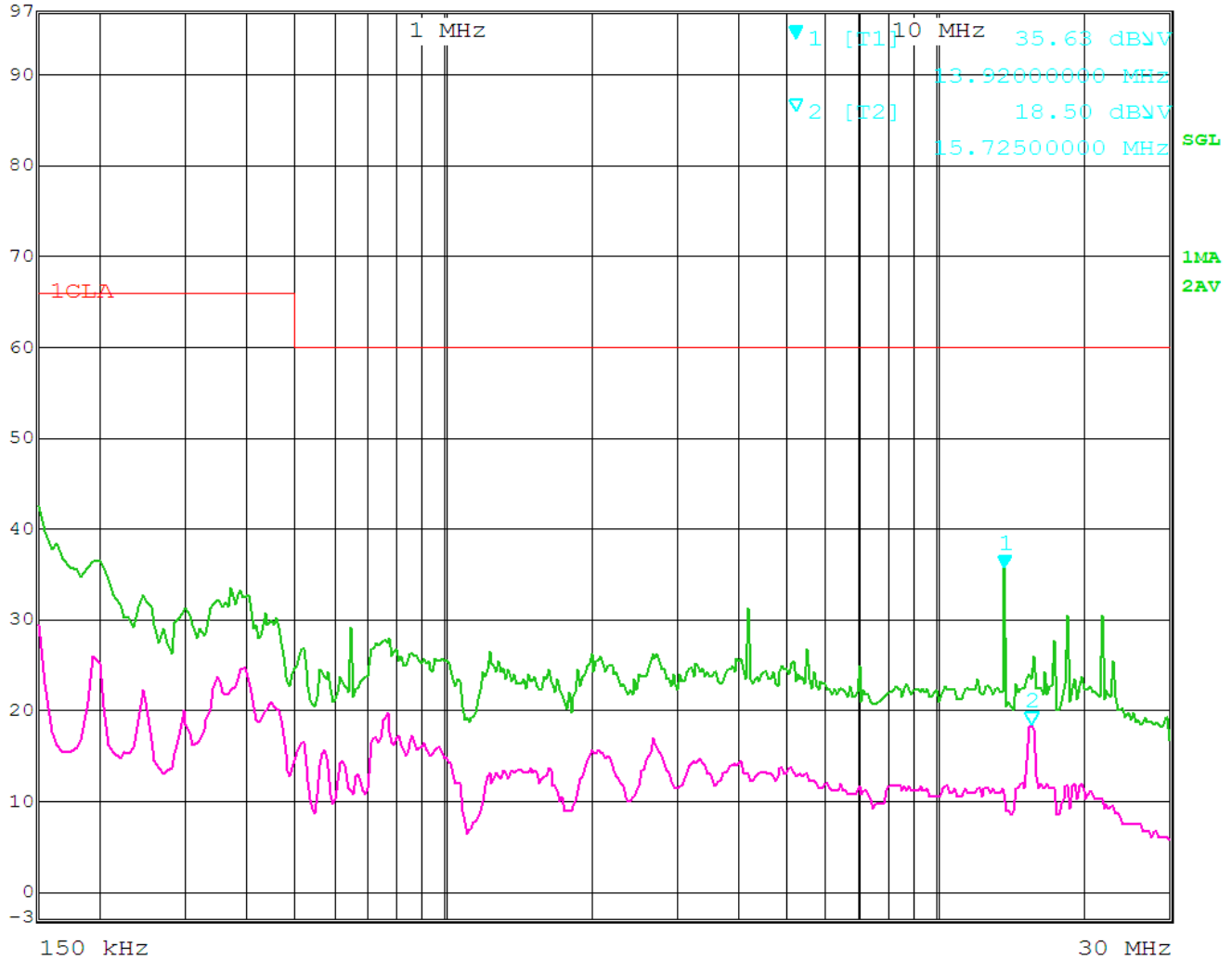

Date: 23.APR.2019 17:14:55

Figure 43 - Conducted Emissions Plot, L-F

All Measurements were found to be at least 10 dB below the limits.



Marker 1 [T1] Det AV Trd ES-K1
 Att 10 dB AUTO 43.84 dBV ResBW 9 kHz
 INPUT 2 18.32500000 MHz Meas T 100 ms Unit dBV

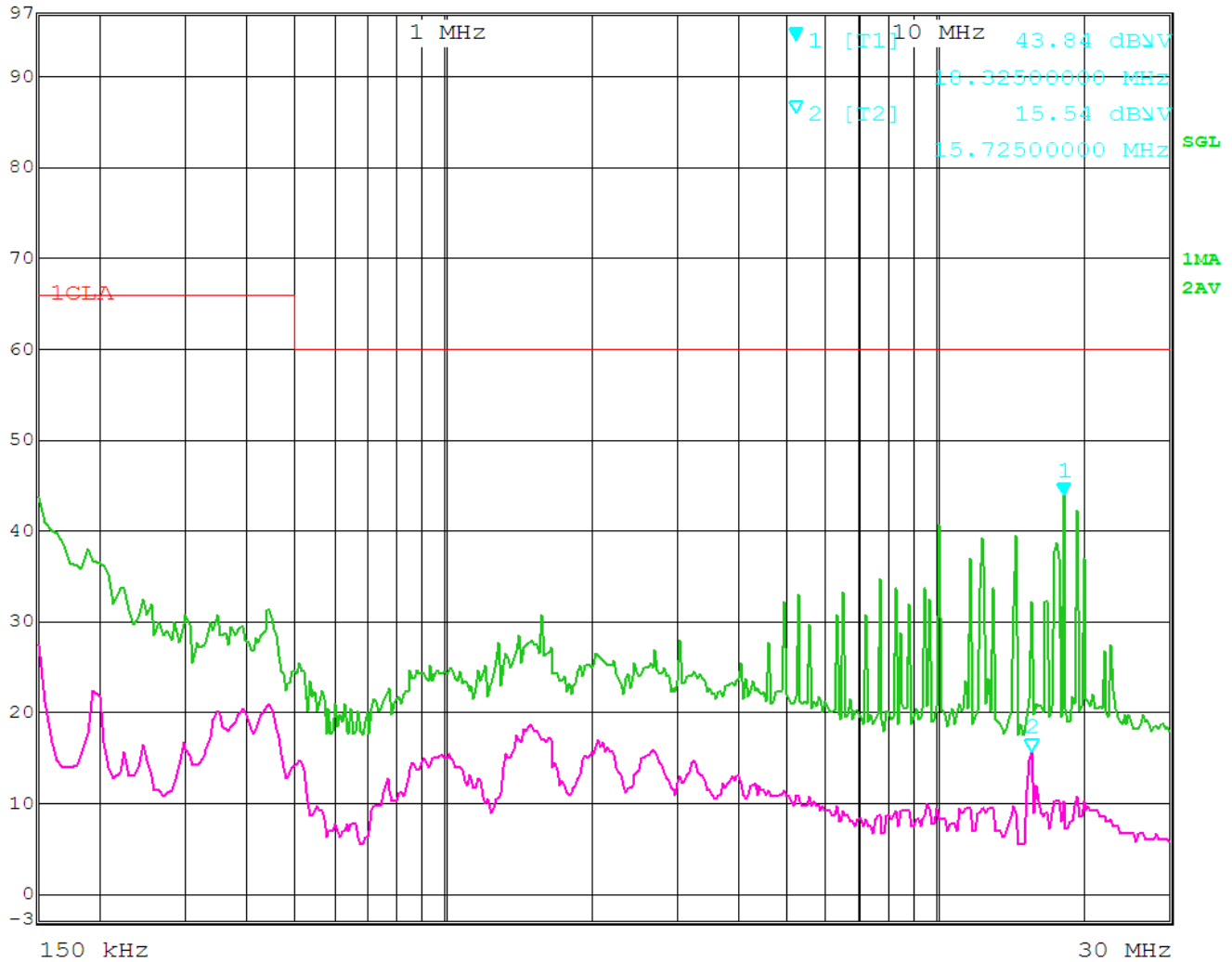

Date: 23.APR.2019 17:05:53

Figure 44 - Conducted Emissions Plot, N-F

All Measurements were found to be at least 10 dB below the limits.



Report Number:	R20190123-20-01	Rev	B
Prepared for:	Garmin		

APPENDIX A: SAMPLE CALCULATION

Field Strength Calculation

The field strength is calculated by adding the Antenna Factor and Cable Factor, and subtracting the Amplifier Gain (if any) from the measured reading. The basic equation with a sample calculation is as follows:

$$FS = RA + AF - (-CF + AG) + AV$$

where FS = Field Strength

RA = Receiver Amplitude

AF = Antenna Factor

CF = Cable Attenuation Factor

AG = Amplifier Gain

AV = Averaging Factor (if applicable)

Assume a receiver reading of 55 dB μ V is obtained. The Antenna Factor of 12 and a Cable Factor of 1.1 is added. The Amplifier Gain of 20 dB is subtracted, giving a field strength of 48.1 dB μ V/m.

$$FS = 55 + 12 - (-1.1 + 20) + 0 = 48.1 \text{ dB}\mu\text{V/m}$$

The 48.1 dB μ V/m value can be mathematically converted to its corresponding level in μ V/m.

$$\text{Level in } \mu\text{V/m} = \text{Common Antilogarithm } [(48.1 \text{ dB}\mu\text{V/m})/20] = 254.1 \mu\text{V/m}$$

AV is calculated by the taking the $20 \cdot \log(T_{on}/100)$ where T_{on} is the maximum transmission time in any 100ms window.



Report Number:	R20190123-20-01	Rev	B
Prepared for:	Garmin		

EIRP Calculations

In cases where direct antenna port measurement is not possible or would be inaccurate, output power is measured in EIRP. The maximum field strength is measured at a specified distance and the EIRP is calculated using the following equation;

$$EIRP (Watts) = [Field Strength (V/m) \times antenna distance (m)]^2 / 30$$

$$Power (watts) = 10^{[Power (dBm)/10]} / 1000$$

$$Voltage (dB\mu V) = Power (dBm) + 107 \text{ (for } 50\Omega \text{ measurement systems)}$$

$$Field Strength (V/m) = 10^{[Field Strength (dB\mu V/m) / 20]} / 10^6$$

$$Gain = 1 \text{ (numeric gain for isotropic radiator)}$$

Conversion from 3m field strength to EIRP (d=3):

$$EIRP = [FS(V/m) \times d^2]/30 = FS [0.3] \quad \text{for } d = 3$$

$$EIRP(dBm) = FS(dB\mu V/m) - 10(\log 10^9) + 10\log[0.3] = FS(dB\mu V/m) - 95.23$$

10log(10^9) is the conversion from micro to milli



Report Number:	R20190123-20-01	Rev	B
Prepared for:	Garmin		

APPENDIX B – MEASUREMENT UNCERTAINTY

Where relevant, the following measurement uncertainty levels have been for tests performed in this test report:

Test	Frequency Range	Uncertainty Value (dB)
Radiated Emissions, 3m	30MHz - 1GHz	3.82
Radiated Emissions, 3m	1GHz - 18GHz	4.44
Emissions limits, conducted	30MHz – 18GHz	±3.30 dB

Expanded uncertainty values are calculated to a confidence level of 95%.



Report Number:

R20190123-20-01

Rev

B

Prepared for:

Garmin

REPORT END