

Application For Grant of Certification

Model: A03485
2402-2480 MHz
47 CFR 15.249 and RSS-210
Low Power Transmitter

FCC ID: IPH-03485
IC: 1792A-03485

FOR

Garmin International, Inc.

1200 East 151st Street
Olathe, KS 66062

FCC Designation: US5305
IC Test Site Registration: 3041A-1
Test Report Number: 181015

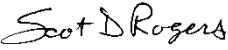
Authorized Signatory: 
Scot D. Rogers

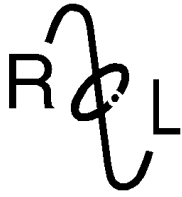

ROGERS LABS, INC.

4405 West 259th Terrace
Louisburg, KS 66053
Phone / Fax (913) 837-3214

Engineering Test Report For Grant of Certification Application

for
47 CFR, PART 15C - Intentional Radiators Paragraph 15.249,
Industry Canada RSS-210 Issue 9, and RSS-GEN Issue 5
License Exempt Intentional Radiator

For
Garmin International, Inc.

1200 East 151st Street
Olathe, KS 66062

Model: A03485

Low Power Transmitter

Frequency Range 2402-2480 MHz
FCC ID: IPH-03485
IC: 1792A-03485

Test Date: October 18, 2018

Certifying Engineer: *Scot D. Rogers*
Scot D. Rogers
Rogers Labs, Inc.
4405 West 259th Terrace
Louisburg, KS 66053
Telephone/Facsimile: (913) 837-3214

This report shall not be reproduced except in full, without the written approval of the laboratory.
This report must not be used by the client to claim product certification, approval, or
endorsement by NVLAP, NIST, or any agency of the Federal Government.

Rogers Labs, Inc.
4405 W. 259th Terrace
Louisburg, KS 66053
Phone/Fax: (913) 837-3214
Revision 1

Garmin International, Inc.
Model: A03485
Test #: 181015
Test to: CFR47 15.249, RSS-210, RSS-Gen
File: A03485 DXX TstRpt 181015

SN's: 88501 / 88605
FCC ID: IPH-03485
IC: 1792A-03485
Date: February 20, 2019
Page 2 of 49

Table of Contents

TABLE OF CONTENTS.....	3
REVISIONS.....	5
FOREWORD.....	6
OPINION / INTERPRETATION OF RESULTS	6
EQUIPMENT TESTED.....	7
Equipment Function and Configuration.....	7
Equipment Configuration.....	8
APPLICATION FOR CERTIFICATION.....	9
APPLICABLE STANDARDS & TEST PROCEDURES	10
TESTING PROCEDURES	10
AC Line Conducted Emission Test Procedure	10
Radiated Emission Test Procedure.....	10
Diagram 1 Test arrangement for Conducted emissions	11
Diagram 2 Test arrangement for radiated emissions of tabletop equipment.....	12
Diagram 3 Test arrangement for radiated emissions tested on Open Area Test Site (OATS).....	13
TEST SITE LOCATIONS	13
LIST OF TEST EQUIPMENT	14
UNITS OF MEASUREMENTS	15
ENVIRONMENTAL CONDITIONS.....	15
STATEMENT OF MODIFICATIONS AND DEVIATIONS	15
INTENTIONAL RADIATORS.....	15
Antenna Requirements	15

Restricted Bands of Operation.....16

Table 1 Radiated Emissions in Restricted Frequency Bands Data ANT (GFSK) 16

Table 2 Radiated Emissions in Restricted Frequency Bands Data BT BR (GFSK) 17

Table 3 Radiated Emissions in Restricted Frequency Bands Data 2EDR (PI/4 DPQSK) 18

Table 4 Radiated Emissions in Restricted Frequency Bands Data 3EDR (8DPSK)..... 19

Table 5 Radiated Emissions in Restricted Frequency Bands Data BLE (GMSK).....20

Summary of Results for Radiated Emissions in Restricted Bands20

AC Line Conducted EMI Procedure21

Figure 1 AC Line Conducted emissions of EUT line 1 (#2, EUT – 362-00096-00)22

Figure 2 AC Line Conducted emissions of EUT line 2 (#2, EUT – 362-00096-00)22

Figure 3 AC Line Conducted emissions of EUT line 1 (#3, EUT – Computer).....23

Figure 4 AC Line Conducted emissions of EUT line 2 (#3, EUT – Computer).....23

Table 6 AC Line Conducted Emissions Data L1 (#2, EUT – 362-00096-00).....24

Table 7 AC Line Conducted Emissions Data L2 (#2, – 362-00096-00).....24

Table 8 AC Line Conducted Emissions Data L1 (#3, EUT – Computer).....25

Table 9 AC Line Conducted Emissions Data L2 (#3, EUT – Computer).....25

Summary of Results for AC Line Conducted Emissions26

General Radiated Emissions Procedure26

Table 10 General Radiated Emissions Data.....27

Summary of Results for General Radiated Emissions27

Operation in the Band 2400 – 2483.5 MHz28

Figure 5 Plot of Transmitter Emissions Operation in 2402-2480 MHz ANT (GFSK).....29

Figure 6 Plot of Transmitter Emissions Operation in 2402-2480 MHz BT BR (GFSK).....29

Figure 7 Plot of Transmitter Emissions Operation in 2402-2480 MHz 2EDR (PI/4 DPQSK).....30

Figure 8 Plot of Transmitter Emissions Operation in 2402-2480 MHz 3EDR (8DPSK)30

Figure 9 Plot of Transmitter Emissions Operation in 2402-2480 MHz BLE (GMSK)31

Figure 10 Plot of Transmitter Emissions 99% Occupied Bandwidth ANT (GFSK)31

Figure 11 Plot of Transmitter Emissions 99% Occupied Bandwidth BT BR (GFSK)32

Figure 12 Plot of Transmitter Emissions 99% Occupied Bandwidth 2EDR (PI/4 DPQSK)32

Figure 13 Plot of Transmitter Emissions 99% Occupied Bandwidth 3EDR (8DPSK).....33

Figure 14 Plot of Transmitter Emissions 99% Occupied Bandwidth BLE (GMSK).....33

Figure 15 Plot of Transmitter Emissions Low Band Edge ANT (GFSK)34

Figure 16 Plot of Transmitter Emissions Low Band Edge BT BR (GFSK)34
 Figure 17 Plot of Transmitter Emissions Low Band Edge 2EDR (PI/4 DPQSK)35
 Figure 18 Plot of Transmitter Emissions Low Band Edge 3EDR (8DPSK).....35
 Figure 19 Plot of Transmitter Emissions Low Band Edge BLE (GMSK).....36
 Figure 20 Plot of Transmitter Emissions High Band Edge ANT (GFSK).....36
 Figure 21 Plot of Transmitter Emissions High Band Edge BT BR (GFSK).....37
 Figure 22 Plot of Transmitter Emissions High Band Edge 2EDR (PI/4 DPQSK)37
 Figure 23 Plot of Transmitter Emissions High Band Edge 3EDR (8DPSK)38
 Figure 24 Plot of Transmitter Emissions High Band Edge BLE (GMSK)38
Transmitter Emissions Data.....39
 Table 11 Transmitter Radiated Emissions ANT (GFSK)39
 Table 12 Transmitter Radiated Emissions BT BR (GFSK)40
 Table 13 Transmitter Radiated Emissions 2EDR (PI/4 DPQSK)41
 Table 14 Transmitter Radiated Emissions 3EDR (8DPSK)42
 Table 15 Transmitter Radiated Emissions BLE (GMSK)43
Summary of Results for Transmitter Radiated Emissions of Intentional Radiator44
ANNEX..... 45
Annex A Measurement Uncertainty Calculations46
Annex B Additional Test Equipment.....47
Annex C Rogers Qualifications48
Annex D Rogers Labs Certificate of Accreditation.....49

Revisions

Revision 1 Issued February 20, 2019

Foreword

The following information is submitted for consideration in obtaining Grant of Certification for low power intentional radiator per 47 CFR Paragraph 15.249, Industry Canada RSS-210 Issue 9 and RSS-GEN Issue 5, low power digital device transmitter operations in the 2400 – 2483.5 MHz frequency band.

Name of Applicant: Garmin International, Inc.
1200 East 151st Street
Olathe, KS 66062

M/N: A03485

FCC ID: IPH-03485 IC: 1792A-03485

Operating Frequency Range: 2402-2480 MHz

Mode	Peak Power (dB μ V/m@3m)	Average power (dB μ V/m@3m)	99% OBW (kHz)
ANT (GFSK)	98.8	87.4	856
BT BR (GFSK)	98.9	87.6	832
BT 2EDR ($\pi/4$ -DQPSK)	98.7	85.4	1,178
BT 3EDR (8DPSK)	98.5	83.5	1,202
BT BLE (GMSK)	98.8	93.1	1,034

Opinion / Interpretation of Results

Tests Performed	Margin (dB)	Results
Restricted Bands 47 CFR 15.205, RSS-210 2.2	-8.4	Complies
AC Line Conducted 47 CFR 15.207, RSS-GEN 8.8	-7.1	Complies
Radiated Emissions 47 CFR 15.209, RSS-GEN 8.9	-7.8	Complies
Harmonic Emissions per 47 CFR 15.249, RSS-210 A2.9	-3.2	Complies

Equipment Tested

<u>Equipment</u>	<u>Model / PN</u>	<u>Serial Number</u>
EUT	A03485	88501
EUT#2	A03485	88605
USB Cable	320-00559-00	N/A
AC Adapter	362-00096-00	P175002627A1
Laptop Computer	Latitude E6320	FCN03Q1
USB Printer	Dell 0N5819	5D1SL61

Test results in this report relate only to the items tested

Equipment Function and Configuration

The EUT is a GPS receiver and display unit providing GPS reception and display of navigation and other information. The EUT offers use as a hand-held, portable, or transportation mounted configuration for use in navigational applications. The design offers cabled and wireless interface capabilities for use with compatible equipment and installations. The design incorporates transmitter circuitries operating in the 2402-2480 MHz band. The EUT provides a single USB interface port for cabled communications and power to recharge internal battery.

The transmitter design provides low power operation across the 2402-2480 MHz band and higher power Digital Transmission System operation in reduced frequency band of 2412-2462 MHz.

Low power operating modes include ANT (GFSK), and the following Bluetooth® modes, Basic Rate (GFSK), 2EDR (PI/4 DQPSK), 3EDR (8DPSK), and BLE (GMSK). Digital Transmission System operation in the 2412-2462 MHz operation using 802.11b,g,n modulations. The EUT was arranged as described by the manufacturer emulating typical user configurations for testing purposes. The EUT offers no other interface connections than those in the configuration options shown below as described by the manufacturer. The EUT operates from internal battery or external power received from compatible source. For testing purposes, the EUT received power from internal battery and/or external power from AC Adapter or support equipment. During testing, the test system was configured to operate in manufacturer defined modes. Some configurations

Rogers Labs, Inc.
 4405 W. 259th Terrace
 Louisburg, KS 66053
 Phone/Fax: (913) 837-3214
 Revision 1

Garmin International, Inc.
 Model: A03485
 Test #: 181015
 Test to: CFR47 15.249, RSS-210, RSS-Gen
 File: A03485 DXX TstRpt 181015

SN's: 88501 / 88605
 FCC ID: IPH-03485
 IC: 1792A-03485
 Date: February 20, 2019
 Page 7 of 49

presented below are not applicable for this report and have been tested and documented in other relevant documentation. Two samples were provided for testing, one representative of production hardware design, and the other modified for testing purposes replacing the integral antennas with RF connection ports. The antenna modification offered testing facility the ability to connect test equipment to the temporary antenna port for antenna port conducted emission testing. The test samples were provided with test software enabling testing personnel the ability to enable transmitter functions on defined channels and modes. As requested by the manufacturer and required by regulations, the equipment was tested for emissions compliance using the available configurations with the worst-case data presented. Test results in this report relate only to the products described in this report.

Equipment Configuration

- 1) Unit operating off internal battery



- 2) Unit connected to (and powered by) AC adapter through USB cable (GPN: 320-00559-00)



- 3) Unit connected to Computer USB port through cable assembly (GPN: 320-00559-00)



Application for Certification

- (1) Manufacturer: Garmin International, Inc.
1200 East 151st Street
Olathe, KS 66062
- (2) Identification: M/N: A03485
FCC ID: IPH-03485 IC: 1792A-03485
- (3) Instruction Book:
Refer to Exhibit for Instruction Manual.
- (4) Description of Circuit Functions:
Refer to Exhibit of Operational Description.
- (5) Block Diagram with Frequencies:
Refer to Exhibit of Operational Description.
- (6) Report of Measurements:
Report of measurements follows in this Report.
- (7) Photographs: Construction, Component Placement, etc.:
Refer to Exhibit for photographs of equipment.
- (8) List of Peripheral Equipment Necessary for operation. The equipment operates from internal battery or direct current power provided from compatible power sources. The EUT offers single USB interface port for power and communications as presented in this filing.
- (9) Transition Provisions of 47 CFR 15.37 are not requested.
- (10) Not Applicable. The unit is not a scanning receiver.
- (11) Not Applicable. The EUT does not operate in the 59 – 64 GHz frequency band.
- (12) The equipment is not software defined and this section is not applicable.
- (13) Applications for certification of U-NII devices in the 5.15-5.35 GHz and the 5.47-5.85 GHz bands must include a high-level operational description of the security procedures that control the radio frequency operating parameters and ensure that unauthorized modifications cannot be made. This requirement is not applicable to his DTS device.
- (14) Contain at least one drawing or photograph showing the test set-up for each of the required types of tests applicable to the device for which certification is requested. These drawings or photographs must show enough detail to confirm other information contained in the test report. Any photographs used must be focused originals without glare or dark spots and must clearly show the test configuration used. This information is provided in this report and Test Setup Exhibits provided with the application filing.

Applicable Standards & Test Procedures

In accordance with the e-CFR Code of Federal Regulations Title 47, dated October 18, 2018: Part 2, Subpart J, Paragraphs 2.907, 2.911, 2.913, 2.925, 2.926, 2.1031 through 2.1057, and applicable parts of paragraph 15, Part 15C Paragraph 15.249, Industry Canada RSS-210 Issue 9, and RSS-GEN Issue 5 operation in the 2400 – 2483.5 MHz Frequency band. Test procedures used are the established Methods of Measurement of Radio-Noise Emissions as described in ANSI C63.10-2013.

Testing Procedures

AC Line Conducted Emission Test Procedure

Testing for the AC line-conducted emissions was performed as defined in ANSI C63.10-2013. The test setup, including the EUT, was arranged in the test configurations as presented during testing. The test configuration was placed on a 1 x 1.5-meter bench, 0.8 meters high located in a screen room. The power lines of the system were isolated from the power source using a standard LISN with a 50- μ Hy choke. EMI was coupled to the spectrum analyzer through a 0.1 μ F capacitor internal to the LISN. The LISN was positioned on the floor beneath the wooden bench supporting the EUT. The power lines and cables were draped over the back edge of the table. Refer to diagram one showing typical test arrangement and photographs in exhibits for EUT placement used during testing.

Radiated Emission Test Procedure

Radiated emissions testing was performed as required in 47 CFR 15C, RSS-210 and specified in ANSI C63.10-2013. The EUT was placed on a rotating 0.9 x 1.2-meter platform, elevated as required above the ground plane at a distance of 3 meters from the FSM antenna. EMI energy was maximized by equipment placement permitting orientation in three orthogonal axes, raising and lowering the FSM antenna, changing the antenna polarization, and by rotating the turntable. Each emission was maximized before data was taken and recorded. The frequency spectrum from 9 kHz to 25,000 MHz was searched for emissions during preliminary investigation. Refer to diagrams two and three showing typical test setup. Refer to photographs in the test setup exhibits for specific EUT placement during testing.

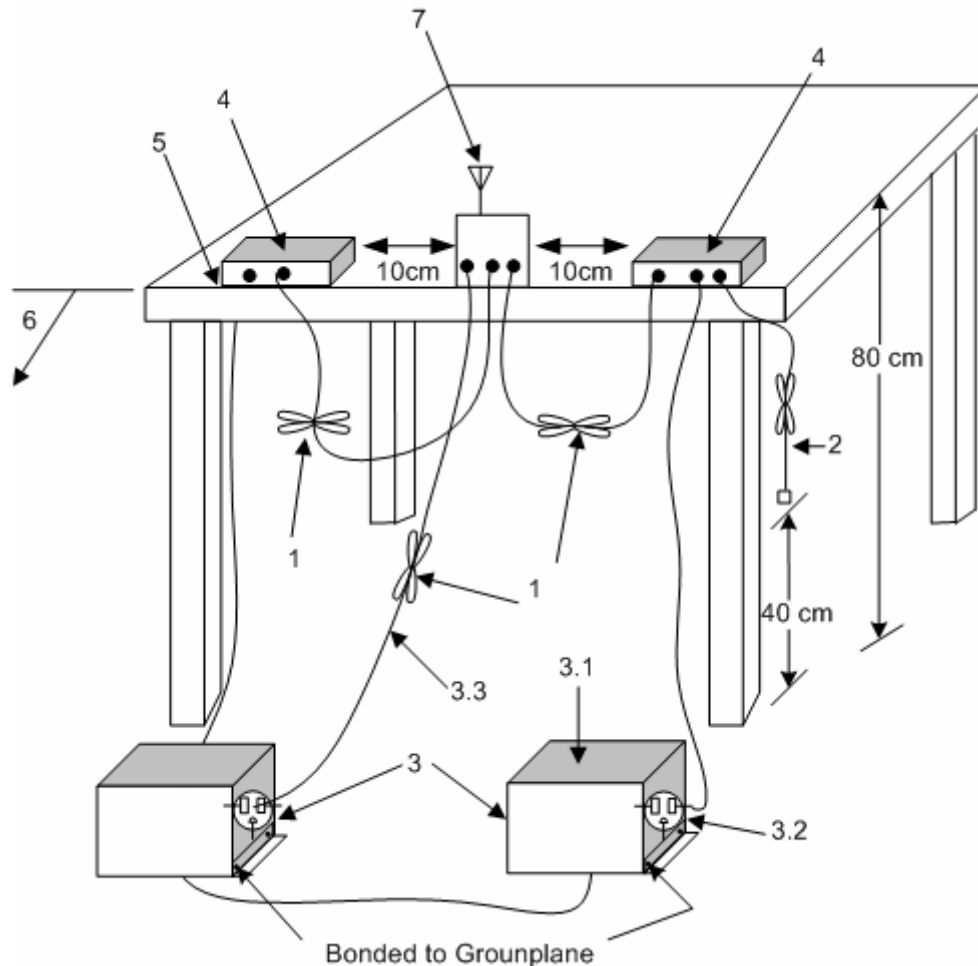

1. Interconnecting cables that hang closer than 40 cm to the ground plane shall be folded back and forth in the center forming a bundle 30 cm to 40 cm long see (see 6.2.3.1).
2. I/O cables that are not connected to an accessory shall be bundled in the center. The end of the cable may be terminated, if required, using the correct terminating impedance. The overall length shall not exceed 1 m (see 6.2.2).
3. EUT connected to one LISN. Unused LISN measuring port connectors shall be terminated in 50 Ω loads. LISN can be placed on top of, or immediately beneath, reference ground plane (see 6.2.2 and 6.2.3).
 - 3.1 All other equipment powered from additional LISN(s).
 - 3.2 Multiple-outlet strip can be used for multiple power cords of non-EUT equipment.
 - 3.3 LISN at least 80 cm from nearest part of EUT chassis.
4. Non-EUT components of EUT system being tested.
5. Rear of EUT, including peripherals, shall all be aligned and flush with rear of tabletop (see 6.2.3.1).
6. Edge of tabletop shall be 40 cm removed from a vertical conducting plane that is bonded to the ground plane (see 6.2.2 for options).
7. Antenna may be integral or detachable. If detachable, the antenna shall be attached for this test.

Diagram 1 Test arrangement for Conducted emissions

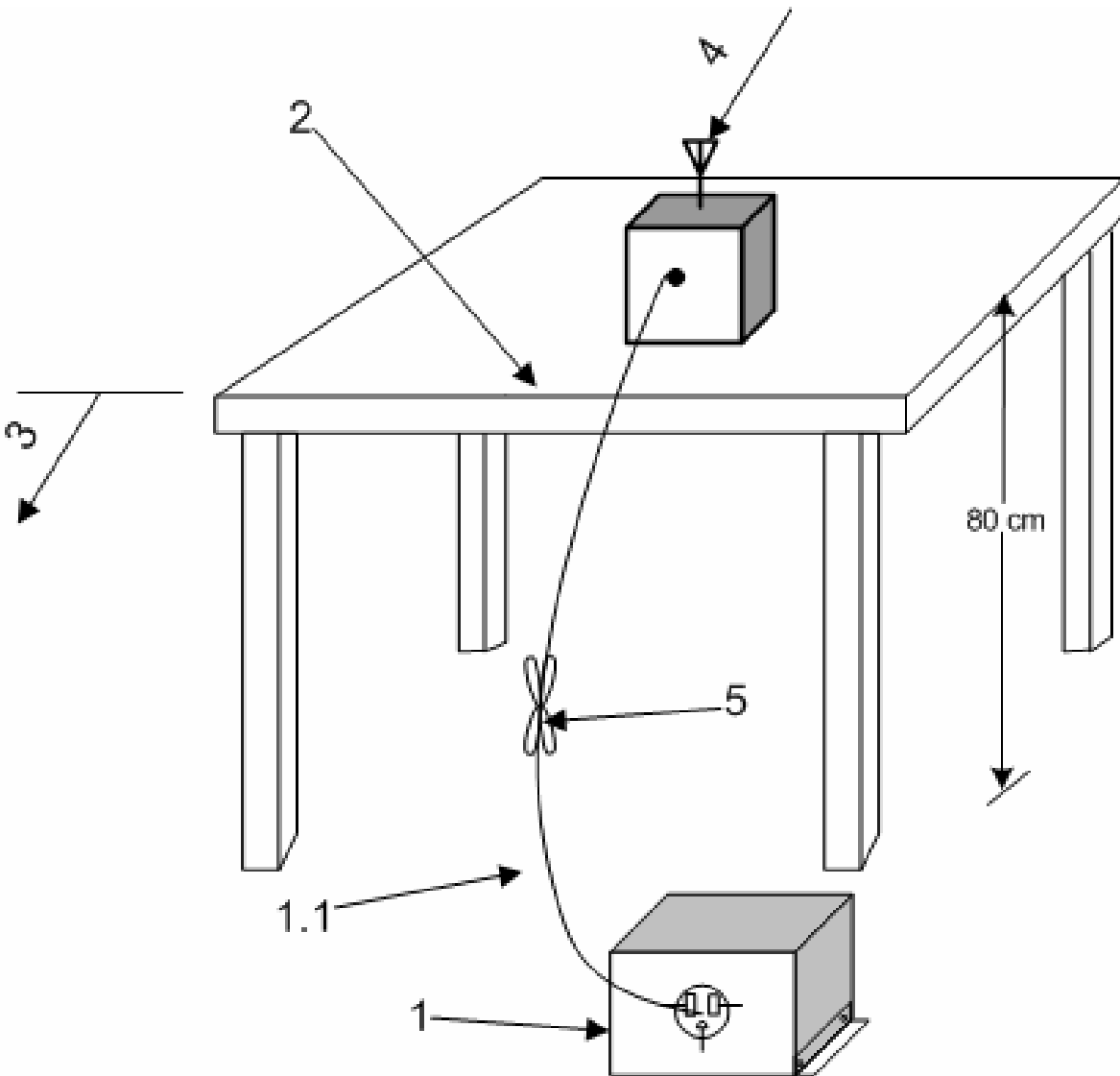

1—A LISN is optional for radiated measurements between 30 MHz and 1000 MHz but not allowed for measurements below 30 MHz and above 1000 MHz (see 6.3.1). If used, then connect EUT to one LISN. Unused LISN measuring port connectors shall be terminated in 50 Ω loads. The LISN may be placed on top of, or immediately beneath, the reference ground plane (see 6.2.2 and 6.2.3.2).

1.1—LISN spaced at least 80 cm from the nearest part of the EUT chassis.

2—Antenna can be integral or detachable, depending on the EUT (see 6.3.1).

3—Interconnecting cables that hang closer than 40 cm to the ground plane shall be folded back and forth in the center forming a bundle 30 cm to 40 cm long (see 6.3.1).

4—For emission measurements at or below 1 GHz, the table height shall be 80 cm. For emission measurements above 1 GHz, the table height shall be 1.5 m for measurements, except as otherwise specified (see 6.3.1 and 6.6.3.1).

Diagram 2 Test arrangement for radiated emissions of tabletop equipment

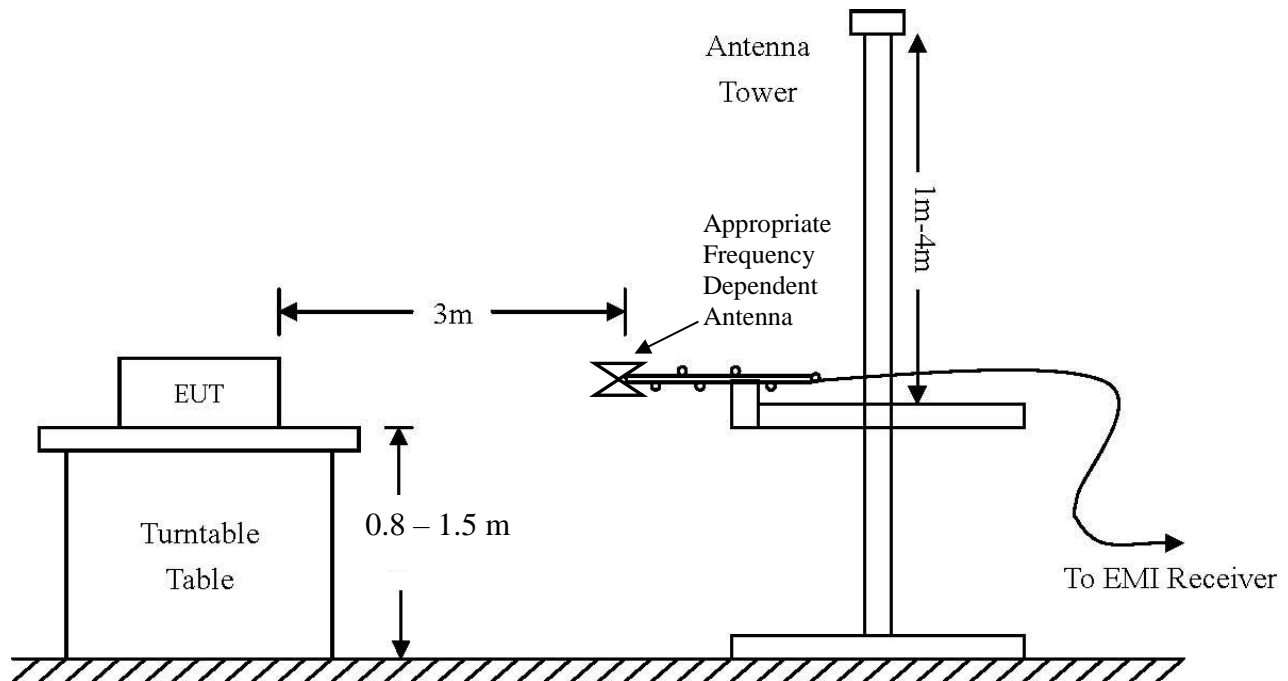

AC Line Conducted Emissions (0.150 -30 MHz)		
RBW	AVG. BW	Detector Function
9 kHz	30 kHz	Peak / Quasi Peak
Emissions (30-1000 MHz)		
RBW	AVG. BW	Detector Function
120 kHz	300 kHz	Peak / Quasi Peak
Emissions (Above 1000 MHz)		
RBW	Video BW	Detector Function
100 kHz	100 kHz	Peak
1 MHz	1 MHz	Peak / Average

Diagram 3 Test arrangement for radiated emissions tested on Open Area Test Site (OATS)

Test Site Locations

Conducted EMI AC line conducted emissions testing performed in a shielded screen room located at Rogers Labs, Inc., 4405 West 259th Terrace, Louisburg, KS

Radiated EMI The radiated emissions tests were performed at the 3 meters, Open Area Test Site (OATS) located at Rogers Labs, Inc., 4405 West 259th Terrace, Louisburg, KS

Registered Site # FCC Site: US5305 and Industry Canada Registration: 3041A-1

NVLAP Accreditation Lab code 200087-0

Rogers Labs, Inc.	Garmin International, Inc.	SN's: 88501 / 88605
4405 W. 259th Terrace	Model: A03485	FCC ID: IPH-03485
Louisburg, KS 66053	Test #: 181015	IC: 1792A-03485
Phone/Fax: (913) 837-3214	Test to: CFR47 15.249, RSS-210, RSS-Gen	Date: February 20, 2019
Revision 1	File: A03485 DXX TstRpt 181015	Page 13 of 49

List of Test Equipment

<u>Equipment</u>	<u>Manufacturer</u>	<u>Model (SN)</u>	<u>Band</u>	<u>Cal Date(m/d/y)</u>	<u>Due</u>
<input checked="" type="checkbox"/> LISN	FCC	FCC-LISN-50-25-10(1PA) (160611)	.15-30MHz	5/2/2018	5/2/2019
<input checked="" type="checkbox"/> LISN	Compliance Design	FCC-LISN-2.Mod.cd,(126)	.15-30MHz	10/16/2018	10/16/2019
<input checked="" type="checkbox"/> Cable	Huber & Suhner Inc.	Sucoflex102ea(L10M)(303073)	9kHz-40 GHz	10/16/2018	10/16/2019
<input checked="" type="checkbox"/> Cable	Huber & Suhner Inc.	Sucoflex102ea(1.5M)(303069)	9kHz-40 GHz	10/16/2018	10/16/2019
<input checked="" type="checkbox"/> Cable	Huber & Suhner Inc.	Sucoflex102ea(1.5M)(303071)	9kHz-40 GHz	10/16/2018	10/16/2019
<input checked="" type="checkbox"/> Cable	Belden	RG-58 (L1-CAT3-11509)	9kHz-30 MHz	10/16/2018	10/16/2019
<input checked="" type="checkbox"/> Cable	Belden	RG-58 (L2-CAT3-11509)	9kHz-30 MHz	10/16/2018	10/16/2019
<input type="checkbox"/> Antenna	ARA	BCD-235-B (169)	20-350MHz	10/16/2018	10/16/2019
<input type="checkbox"/> Antenna	EMCO	3147 (40582)	200-1000MHz	10/16/2018	10/16/2019
<input checked="" type="checkbox"/> Antenna	ETS-Lindgren	3117 (200389)	1-18 GHz	5/2/2018	5/2/2020
<input type="checkbox"/> Antenna	Com Power	AH-118 (10110)	1-18 GHz	10/16/2018	10/24/2019
<input checked="" type="checkbox"/> Antenna	Com Power	AH-840 (101046)	18-40 GHz	5/15/2017	5/15/2019
<input checked="" type="checkbox"/> Antenna	Com Power	AL-130 (121055)	.001-30 MHz	10/16/2018	10/16/2019
<input checked="" type="checkbox"/> Antenna	Sunol	JB-6 (A100709)	30-1000 MHz	10/16/2018	10/16/2019
<input checked="" type="checkbox"/> Analyzer	Rohde & Schwarz	ESU40 (100108)	20Hz-40GHz	5/2/2018	5/2/2019
<input checked="" type="checkbox"/> Analyzer	Rohde & Schwarz	ESW44 (101534)	20Hz-44GHz	12/22/2017	12/22/2018
<input type="checkbox"/> Analyzer	Rohde & Schwarz	FS-Z60, 90, 140, and 220	40GHz-220GHz	12/22/2017	12/22/2019
<input checked="" type="checkbox"/> Amplifier	Com-Power	PA-010 (171003)	100Hz-30MHz	10/16/2018	10/16/2019
<input checked="" type="checkbox"/> Amplifier	Com-Power	CPPA-102 (01254)	1-1000 MHz	10/16/2018	10/16/2019
<input checked="" type="checkbox"/> Amplifier	Com-Power	PAM-118A (551014)	0.5-18 GHz	10/16/2018	10/16/2019
<input checked="" type="checkbox"/> Amplifier	Com-Power	PAM-840A (461328)	18-40 GHz	10/16/2018	10/16/2019
<input type="checkbox"/> Power Meter	Agilent	N1911A with N1921A	0.05-40 GHz	5/2/2018	5/2/2019
<input type="checkbox"/> Generator	Rohde & Schwarz	SMB100A6 (100150)	20Hz-6 GHz	5/2/2018	5/2/2019
<input type="checkbox"/> Generator	Rohde & Schwarz	SMBV100A6 (260771)	20Hz-6 GHz	5/2/2018	5/2/2019
<input type="checkbox"/> RF Filter	Micro-Tronics	BRC50722 (009).9G notch	30-1800 MHz	5/2/2018	5/2/2019
<input type="checkbox"/> RF Filter	Micro-Tronics	HPM50114 (017)1.5G HPF	30-18000 MHz	5/2/2018	5/2/2019
<input type="checkbox"/> RF Filter	Micro-Tronics	HPM50117 (063) 3G HPF	30-18000 MHz	5/2/2018	5/2/2019
<input type="checkbox"/> RF Filter	Micro-Tronics	HPM50105 (059) 6G HPF	30-18000 MHz	5/2/2018	5/2/2019
<input type="checkbox"/> RF Filter	Micro-Tronics	BRM50702 (172) 2G notch	30-1800 MHz	5/2/2018	5/2/2019
<input type="checkbox"/> RF Filter	Micro-Tronics	BRC50703 (G102) 5G notch	30-1800 MHz	5/2/2018	5/2/2019
<input type="checkbox"/> RF Filter	Micro-Tronics	BRC50705 (024) 5G notch	30-1800 MHz	5/2/2018	5/2/2019
<input type="checkbox"/> Attenuator	Fairview	SA6NFN100W-14 (1625)	30-1800 MHz	5/2/2018	5/2/2019
<input type="checkbox"/> Attenuator	Mini-Circuits	VAT-3W2+ (1735)	30-6000 MHz	5/2/2018	5/2/2019
<input type="checkbox"/> Attenuator	Mini-Circuits	VAT-3W2+ (1436)	30-6000 MHz	5/2/2018	5/2/2019
<input type="checkbox"/> Attenuator	Mini-Circuits	VAT-3W2+ (14362)	30-6000 MHz	5/2/2018	5/2/2019
<input type="checkbox"/> Attenuator	Mini-Circuits	VAT-3W2+ (1445)	30-6000 MHz	5/2/2018	5/2/2019
<input type="checkbox"/> Attenuator	Mini-Circuits	VAT-3W2+ (14452)	30-6000 MHz	5/2/2018	5/2/2019
<input type="checkbox"/> Attenuator	Mini-Circuits	VAT-6W2+ (1438)	30-6000 MHz	5/2/2018	5/2/2019
<input type="checkbox"/> Attenuator	Mini-Circuits	VAT-6W2+ (1736)	30-6000 MHz	5/2/2018	5/2/2019
<input type="checkbox"/> Attenuator	JFW Industries	50FH-010-10 (1)	30-18000 MHz	5/2/2018	5/2/2019
<input checked="" type="checkbox"/> Weather station	Davis	6312 (A81120N075)		10/26/2018	10/26/2019

Rogers Labs, Inc.
4405 W. 259th Terrace
Louisburg, KS 66053
Phone/Fax: (913) 837-3214
Revision 1

Garmin International, Inc.
Model: A03485
Test #: 181015
Test to: CFR47 15.249, RSS-210, RSS-Gen
File: A03485 DXX TstRpt 181015

SN's: 88501 / 88605
FCC ID: IPH-03485
IC: 1792A-03485
Date: February 20, 2019
Page 14 of 49

Units of Measurements

Conducted EMI Data is in dB μ V; dB referenced to one microvolt

Radiated EMI Data is in dB μ V/m; dB/m referenced to one microvolt per meter

Sample Calculation:

RFS = Radiated Field Strength, FSM = Field Strength Measured

A.F. = Receive antenna factor, Gain = amplification gains and/or cable losses

$RFS (dB\mu V/m @ 3m) = FSM (dB\mu V) + A.F. (dB) - Gain (dB)$

Environmental Conditions

Ambient Temperature 20.8° C

Relative Humidity 40%

Atmospheric Pressure 1031.0 mb

Statement of Modifications and Deviations

No modifications to the EUT were required for the equipment to demonstrate compliance with the 47 CFR Part 15C, 15.249, Industry Canada RSS-210 Issue 9, and RSS-GEN Issue 5 emission requirements. There were no deviations to the specifications.

Intentional Radiators

The following information is submitted supporting compliance with the requirements of 47 CFR, Subpart C, paragraph 15.249, Industry Canada RSS-210 Issue 9 and RSS-GEN Issue 5.

Antenna Requirements

The EUT incorporates integral antenna system. Production equipment offers no provision for connection to alternate antenna system. The antenna connection point complies with the unique antenna connection requirements. There are no deviations or exceptions to the specification.

Restricted Bands of Operation

Spurious emissions falling in the restricted frequency bands of operation were measured at the OATS. The EUT utilizes frequency, determining circuitry, which generates harmonics falling in the restricted bands. Emissions were investigated at the OATS, using appropriate antennas or pyramidal horns, amplification stages, and a spectrum analyzer. Peak and average amplitudes of frequencies above 1000 MHz were compared to the required limits with worst-case data presented below. Test procedures of ANSI C63.10-2013 were used during testing. No other significant emission was observed which fell into the restricted bands of operation. Computed emission values take into account the received radiated field strength, receive antenna correction factor, amplifier gain stage, and test system cable losses.

Table 1 Radiated Emissions in Restricted Frequency Bands Data ANT (GFSK)

Frequency in MHz	Horizontal Peak (dB μ V/m)	Horizontal Quasi-Peak (dB μ V/m)	Horizontal Average (dB μ V/m)	Vertical Peak (dB μ V/m)	Vertical Quasi-Peak (dB μ V/m)	Vertical Average (dB μ V/m)	Limit @ 3m (dB μ V/m)
2390.0	43.5	N/A	30.4	43.5	N/A	30.3	54.0
2483.5	53.4	N/A	30.7	48.1	N/A	30.8	54.0
4804.0	46.5	N/A	34.1	47.2	N/A	34.4	54.0
4882.0	47.5	N/A	34.7	47.6	N/A	34.6	54.0
4960.0	47.5	N/A	34.5	47.4	N/A	34.4	54.0
7206.0	51.1	N/A	38.1	51.1	N/A	38.1	54.0
7323.0	51.1	N/A	38.1	51.6	N/A	38.1	54.0
7440.0	51.2	N/A	37.6	50.5	N/A	37.5	54.0
12010.0	55.8	N/A	43.2	56.2	N/A	43.1	54.0
12205.0	58.2	N/A	45.6	58.6	N/A	45.6	54.0
12400.0	57.8	N/A	44.9	57.8	N/A	44.9	54.0

Other emissions present had amplitudes at least 20 dB below the limit. Peak and Quasi-Peak amplitude emissions are recorded for frequency range below 1000 MHz. Peak and Average amplitude emissions are recorded for frequency range above 1000 MHz.

Table 2 Radiated Emissions in Restricted Frequency Bands Data BT BR (GFSK)

Frequency in MHz	Horizontal Peak (dB μ V/m)	Horizontal Quasi-Peak (dB μ V/m)	Horizontal Average (dB μ V/m)	Vertical Peak (dB μ V/m)	Vertical Quasi-Peak (dB μ V/m)	Vertical Average (dB μ V/m)	Limit @ 3m (dB μ V/m)
2390.0	43.2	N/A	30.0	43.3	N/A	30.2	54.0
2483.5	43.7	N/A	30.8	49.9	N/A	30.8	54.0
4804.0	46.8	N/A	33.8	46.5	N/A	34.1	54.0
4882.0	47.8	N/A	34.5	47.5	N/A	34.5	54.0
4960.0	46.5	N/A	34.0	47.1	N/A	34.1	54.0
7206.0	50.4	N/A	38.1	50.9	N/A	38.1	54.0
7323.0	50.5	N/A	38.0	50.6	N/A	38.0	54.0
7440.0	50.4	N/A	37.5	50.5	N/A	37.5	54.0
12010.0	56.8	N/A	43.2	55.7	N/A	43.0	54.0
12205.0	58.3	N/A	45.4	58.4	N/A	45.5	54.0
12400.0	57.6	N/A	44.8	58.6	N/A	44.8	54.0

Other emissions present had amplitudes at least 20 dB below the limit. Peak and Quasi-Peak amplitude emissions are recorded for frequency range below 1000 MHz. Peak and Average amplitude emissions are recorded for frequency range above 1000 MHz.

Table 3 Radiated Emissions in Restricted Frequency Bands Data 2EDR (PI/4 DPQSK)

Frequency in MHz	Horizontal Peak (dBμV/m)	Horizontal Quasi-Peak (dBμV/m)	Horizontal Average (dBμV/m)	Vertical Peak (dBμV/m)	Vertical Quasi-Peak (dBμV/m)	Vertical Average (dBμV/m)	Limit @ 3m (dBμV/m)
2390.0	43.4	N/A	29.9	43.1	N/A	30.1	54.0
2483.5	54.2	N/A	30.8	50.8	N/A	30.9	54.0
4804.0	46.8	N/A	33.5	47.1	N/A	34.1	54.0
4882.0	47.3	N/A	34.2	47.0	N/A	34.2	54.0
4960.0	47.2	N/A	34.7	47.6	N/A	34.4	54.0
7206.0	51.5	N/A	38.0	50.9	N/A	37.9	54.0
7323.0	50.3	N/A	38.0	51.0	N/A	37.9	54.0
7440.0	51.5	N/A	38.4	50.3	N/A	37.5	54.0
12010.0	56.1	N/A	43.2	55.6	N/A	43.2	54.0
12205.0	58.1	N/A	45.4	58.6	N/A	45.4	54.0
12400.0	57.7	N/A	45.1	57.8	N/A	44.9	54.0

Other emissions present had amplitudes at least 20 dB below the limit. Peak and Quasi-Peak amplitude emissions are recorded for frequency range below 1000 MHz. Peak and Average amplitude emissions are recorded for frequency range above 1000 MHz.

Table 4 Radiated Emissions in Restricted Frequency Bands Data 3EDR (8DPSK)

Frequency in MHz	Horizontal Peak (dBµV/m)	Horizontal Quasi-Peak (dBµV/m)	Horizontal Average (dBµV/m)	Vertical Peak (dBµV/m)	Vertical Quasi-Peak (dBµV/m)	Vertical Average (dBµV/m)	Limit @ 3m (dBµV/m)
2390.0	42.9	N/A	30.0	43.1	N/A	30.1	54.0
2483.5	49.1	N/A	30.7	52.2	N/A	30.8	54.0
4804.0	47.1	N/A	34.2	47.2	N/A	34.1	54.0
4882.0	47.2	N/A	34.2	48.4	N/A	35.2	54.0
4960.0	47.4	N/A	34.1	47.3	N/A	34.1	54.0
7206.0	51.6	N/A	38.0	50.6	N/A	38.0	54.0
7323.0	50.6	N/A	37.9	51.5	N/A	38.7	54.0
7440.0	50.2	N/A	37.4	50.1	N/A	37.4	54.0
12010.0	56.1	N/A	43.2	55.7	N/A	43.0	54.0
12205.0	58.8	N/A	45.4	58.2	N/A	45.4	54.0
12400.0	58.1	N/A	44.9	57.5	N/A	44.9	54.0

Other emissions present had amplitudes at least 20 dB below the limit. Peak and Quasi-Peak amplitude emissions are recorded for frequency range below 1000 MHz. Peak and Average amplitude emissions are recorded for frequency range above 1000 MHz.

Table 5 Radiated Emissions in Restricted Frequency Bands Data BLE (GMSK)

Frequency in MHz	Horizontal Peak (dBμV/m)	Horizontal Quasi-Peak (dBμV/m)	Horizontal Average (dBμV/m)	Vertical Peak (dBμV/m)	Vertical Quasi-Peak (dBμV/m)	Vertical Average (dBμV/m)	Limit @ 3m (dBμV/m)
2390.0	43.5	N/A	29.9	43.3	N/A	30.1	54.0
2483.5	48.6	N/A	30.7	53.3	N/A	31.2	54.0
4804.0	46.8	N/A	33.9	47.2	N/A	34.2	54.0
4880.0	47.1	N/A	33.9	47.9	N/A	34.8	54.0
4960.0	47.7	N/A	34.3	47.1	N/A	34.5	54.0
7206.0	51.1	N/A	38.0	51.7	N/A	38.0	54.0
7320.0	50.7	N/A	38.0	51.0	N/A	37.9	54.0
7440.0	50.3	N/A	37.5	51.2	N/A	37.5	54.0
12010.0	55.6	N/A	43.2	55.4	N/A	43.2	54.0
12200.0	57.7	N/A	45.2	58.1	N/A	45.2	54.0
12400.0	57.2	N/A	44.9	58.1	N/A	44.9	54.0

Other emissions present had amplitudes at least 20 dB below the limit. Peak and Quasi-Peak amplitude emissions are recorded for frequency range below 1000 MHz. Peak and Average amplitude emissions are recorded for frequency range above 1000 MHz.

Summary of Results for Radiated Emissions in Restricted Bands

The EUT demonstrated compliance with the radiated emissions requirements of 47 CFR Part 15C and RSS-210 Intentional Radiator requirements. The EUT demonstrated a worst-case minimum margin of -8.4 dB below the emissions requirements in restricted frequency bands. Peak, Quasi-peak, and average amplitudes were checked for compliance with the regulations. Worst-case emissions are reported with other emissions found in the restricted frequency bands at least 20 dB below the requirements.

AC Line Conducted EMI Procedure

The EUT was arranged in typical equipment configurations as offered by manufacturer and presented above in equipment configuration. AC Line Conducted emission testing was performed with the EUT placed on a 1 x 1.5-meter bench 80 cm above the conducting ground plane, floor of a screen room. The bench was positioned 40 cm away from the wall of the screen room. The LISN was positioned on the floor of the screen room 80-cm from the rear of the EUT. Testing for the AC line-conducted emissions followed the procedures of ANSI C63.10-2013. The EUT was configured as presented in the AC Line conducted configurations as directed by the manufacture and presented above in equipment configuration. The AC adapter for the EUT was connected to the LISN for AC line-conducted emissions testing. A second LISN was positioned on the floor of the screen room 80-cm from the rear of the supporting equipment of the test configuration. All power cords except the EUT were then powered from the second LISN. EMI was coupled to the spectrum analyzer through a 0.1 μ F capacitor, internal to the LISN. Power line conducted emissions testing was carried out individually for each current carrying conductor of the EUT. The excess length of lead between the system and the LISN receptacle was folded back and forth to form a bundle not exceeding 40 cm in length. The screen room, conducting ground plane, analyzer, and LISN were bonded together to the protective earth ground. Preliminary testing was performed to identify the frequencies of each of the emissions, which demonstrated the highest amplitudes. The cables were repositioned to obtain maximum amplitude of measured EMI level. Once the worst-case configuration was identified, plots were made of the EMI from 0.15 MHz to 30 MHz and data recorded.

Refer to figures one and two showing plots of the AC Adapter configuration worst-case line conducted emissions. Refer to figures three and four for plots of the EUT – USB Computer interface AC Line conducted emissions.

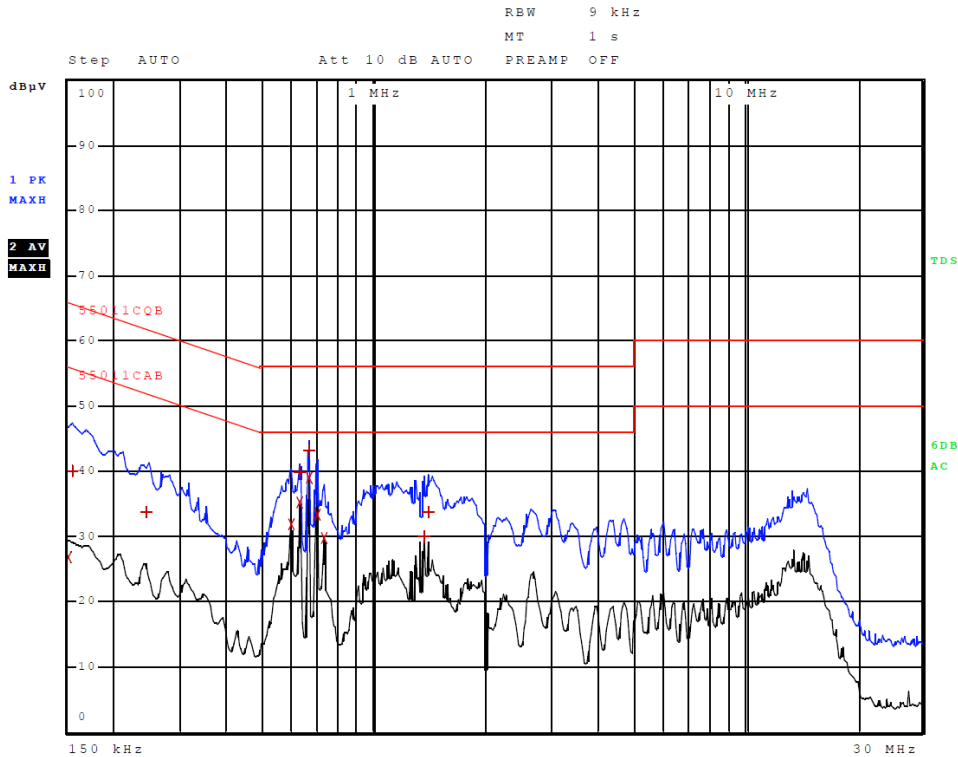

Figure 1 AC Line Conducted emissions of EUT line 1 (#2, EUT – 362-00096-00)

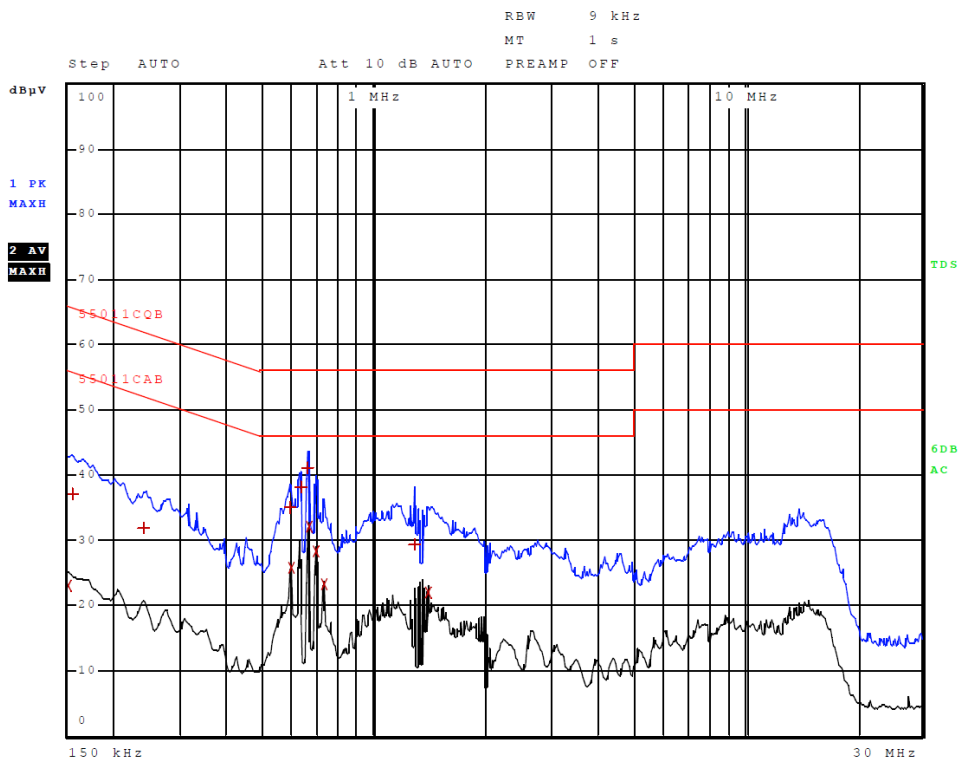

Figure 2 AC Line Conducted emissions of EUT line 2 (#2, EUT – 362-00096-00)

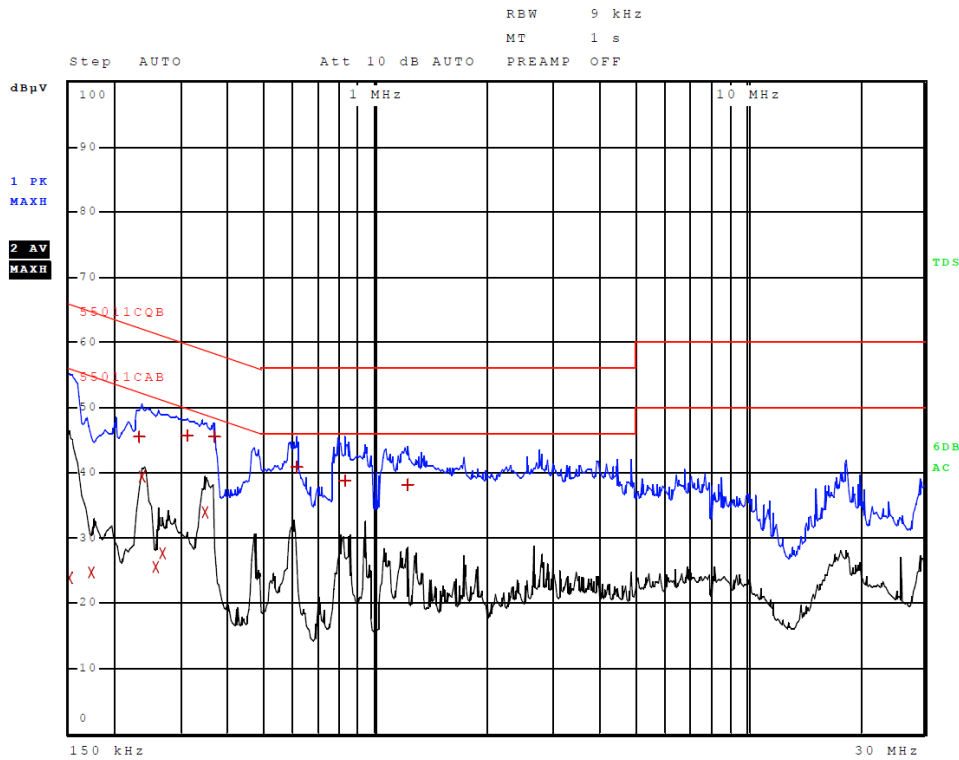

Figure 3 AC Line Conducted emissions of EUT line 1 (#3, EUT – Computer)

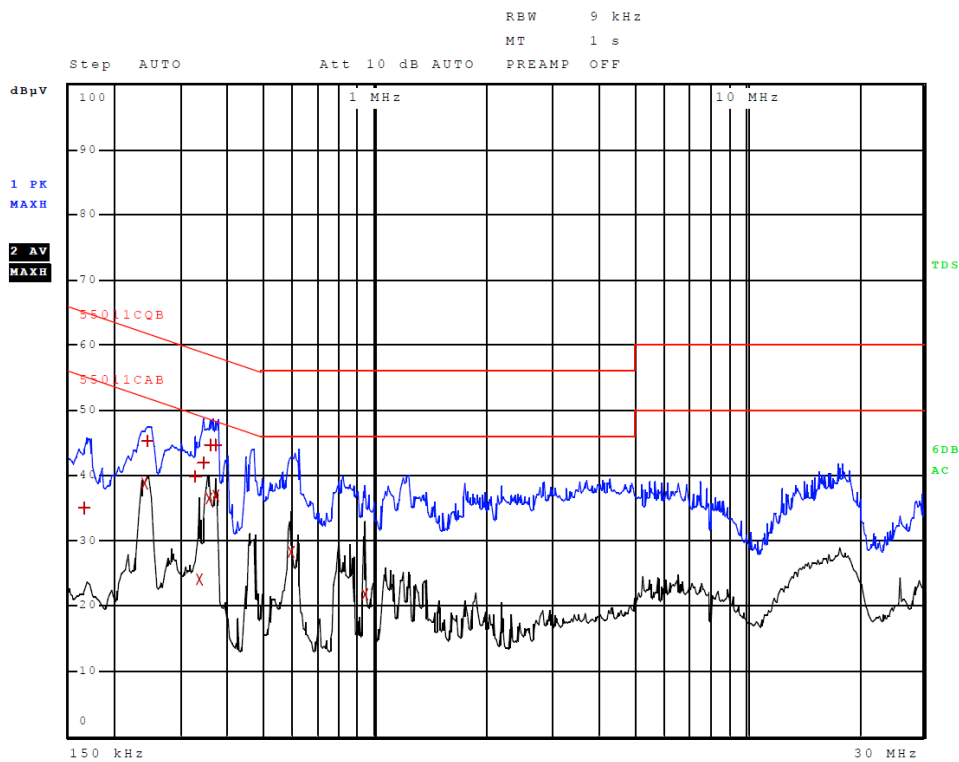

Figure 4 AC Line Conducted emissions of EUT line 2 (#3, EUT – Computer)

Table 6 AC Line Conducted Emissions Data L1 (#2, EUT – 362-00096-00)

Trace	Frequency	Level (dBµV)	Detector	Delta Limit/dB
2	150.000000000 kHz	26.72	Average	-29.28
1	154.000000000 kHz	40.00	Quasi Peak	-25.79
1	246.000000000 kHz	33.65	Quasi Peak	-28.24
2	594.000000000 kHz	31.80	Average	-14.20
2	626.000000000 kHz	35.18	Average	-10.82
1	626.000000000 kHz	39.88	Quasi Peak	-16.12
2	662.000000000 kHz	38.91	Average	-7.09
1	662.000000000 kHz	43.20	Quasi Peak	-12.80
2	698.000000000 kHz	33.32	Average	-12.68
2	730.000000000 kHz	29.80	Average	-16.20
1	1.362000000 MHz	29.91	Quasi Peak	-26.09
1	1.394000000 MHz	33.64	Quasi Peak	-22.36

Other emissions present had amplitudes at least 20 dB below the limit.

Table 7 AC Line Conducted Emissions Data L2 (#2, – 362-00096-00)

Trace	Frequency	Level (dBµV)	Detector	Delta Limit/dB
2	150.000000000 kHz	22.92	Average	-33.08
1	154.000000000 kHz	36.98	Quasi Peak	-28.80
1	242.000000000 kHz	31.85	Quasi Peak	-30.18
1	590.000000000 kHz	35.01	Quasi Peak	-20.99
2	594.000000000 kHz	25.82	Average	-20.18
1	630.000000000 kHz	38.11	Quasi Peak	-17.89
1	658.000000000 kHz	41.07	Quasi Peak	-14.93
2	662.000000000 kHz	32.04	Average	-13.96
2	694.000000000 kHz	28.34	Average	-17.66
2	730.000000000 kHz	23.14	Average	-22.86
1	1.282000000 MHz	29.39	Quasi Peak	-26.61
2	1.390000000 MHz	22.03	Average	-23.97

Other emissions present had amplitudes at least 20 dB below the limit.

Table 8 AC Line Conducted Emissions Data L1 (#3, EUT – Computer)

Trace	Frequency	Level (dBµV)	Detector	Delta Limit/dB
2	150.000000000 kHz	23.90	Average	-32.10
2	174.000000000 kHz	24.59	Average	-30.17
1	234.000000000 kHz	45.41	Quasi Peak	-16.90
2	238.000000000 kHz	39.45	Average	-12.72
2	258.000000000 kHz	25.43	Average	-26.07
2	266.000000000 kHz	27.59	Average	-23.66
1	310.000000000 kHz	45.62	Quasi Peak	-14.35
2	346.000000000 kHz	33.96	Average	-15.10
1	366.000000000 kHz	45.41	Quasi Peak	-13.18
1	610.000000000 kHz	40.77	Quasi Peak	-15.23
1	822.000000000 kHz	38.79	Quasi Peak	-17.21
1	1.218000000 MHz	38.15	Quasi Peak	-17.85

Other emissions present had amplitudes at least 20 dB below the limit.

Table 9 AC Line Conducted Emissions Data L2 (#3, EUT – Computer)

Trace	Frequency	Level (dBµV)	Detector	Delta Limit/dB
1	166.000000000 kHz	34.93	Quasi Peak	-30.23
2	242.000000000 kHz	38.80	Average	-13.23
1	246.000000000 kHz	45.22	Quasi Peak	-16.67
1	326.000000000 kHz	39.91	Quasi Peak	-19.64
2	334.000000000 kHz	24.10	Average	-25.26
1	342.000000000 kHz	41.89	Quasi Peak	-17.27
2	354.000000000 kHz	36.51	Average	-12.36
1	362.000000000 kHz	44.58	Quasi Peak	-14.11
2	370.000000000 kHz	36.84	Average	-11.66
1	374.000000000 kHz	44.71	Quasi Peak	-13.70
2	590.000000000 kHz	28.24	Average	-17.76
2	934.000000000 kHz	21.67	Average	-24.33

Other emissions present had amplitudes at least 20 dB below the limit.

Summary of Results for AC Line Conducted Emissions

The EUT demonstrated compliance with the AC Line Conducted Emissions requirements of 47CFR Part 15C, RSS-210 and RSS-Gen. The EUT configurations #2 worst-case configuration demonstrated a minimum margin of -7.1 dB below the requirement. The EUT configuration #4 worst-case configuration demonstrated a minimum margin of -11.7 dB below the requirement. Other emissions were present with amplitudes at least 20 dB below the limit and worst-case amplitudes recorded.

General Radiated Emissions Procedure

The EUT was arranged in typical equipment configurations and operated through available modes during testing. Preliminary testing was performed in a screen room with the EUT positioned 1 meter from the FSM. Radiated emissions measurements were performed to identify the frequencies, which produced the highest emissions. Each radiated emission was then maximized at the OATS location before final radiated measurements were performed. Final data was taken with the EUT located at the OATS at a distance of 3 meters between the EUT and the receiving antenna. The frequency spectrum from 9 kHz to 25,000 MHz was searched for general radiated emissions. Measured emission levels were maximized by EUT placement on the table, rotating the turntable through 360 degrees, varying the antenna height between 1 and 4 meters above the ground plane and changing antenna position between horizontal and vertical polarization. Antennas used were Loop from 9 kHz to 30 MHz, Broadband Biconical from 30 to 200 MHz, Biconilog from 30 to 1000 MHz, Log Periodic from 200 MHz to 1 GHz and or double Ridge or pyramidal horns and mixers above 1 GHz, notch filters and appropriate amplifiers and external mixers were utilized.

Table 10 General Radiated Emissions Data

Frequency in MHz	Horizontal Peak (dB μ V/m)	Horizontal Quasi-Peak (dB μ V/m)	Horizontal Average (dB μ V/m)	Vertical Peak (dB μ V/m)	Vertical Quasi-Peak (dB μ V/m)	Vertical Average (dB μ V/m)	Limit @ 3m (dB μ V/m)
35.4	26.9	22.0	N/A	37.8	32.2	N/A	40.0
53.1	27.3	19.8	N/A	35.5	29.0	N/A	40.0
70.7	36.3	29.5	N/A	31.7	26.1	N/A	40.0
79.8	29.0	19.6	N/A	31.4	25.8	N/A	40.0
208.9	19.3	12.0	N/A	16.4	9.3	N/A	40.0
247.0	20.4	14.2	N/A	16.7	11.1	N/A	47.0

Other emissions present had amplitudes at least 20 dB below the limit. Peak and Quasi-Peak amplitude emissions are recorded for frequency range below 1000 MHz. Peak and Average amplitude emissions are recorded for frequency range above 1000 MHz.

Summary of Results for General Radiated Emissions

The EUT demonstrated compliance with the radiated emissions requirements of 47 CFR Part 15C paragraph 15.209, RSS-210 and RSS-GEN Intentional Radiators. The EUT demonstrated a minimum margin of -7.8 dB below the requirements. Other emissions were present with amplitudes at least 20 dB below the Limits.

Operation in the Band 2400 – 2483.5 MHz

The transmitter output power; harmonic and general emissions were measured on an open area test site @ 3 meters. The EUT was placed on a turntable elevated as required above the ground plane and at a distance of 3 meters from the FSM antenna. The peak and quasi-peak amplitude of frequencies below 1000 MHz were measured using a spectrum analyzer. The peak and average amplitude of frequencies above 1000 MHz were measured using a spectrum analyzer. The amplitude of each emission was then recorded from the analyzer display. Emissions radiated outside of the specified bands, except for harmonics, shall be attenuated by at least 50 dB below the level of the fundamental or to the general radiated emission limits, whichever is the lesser attenuation. Antenna port emission plots were taken of transmitter performance for reference in this and other documentation using test sample #2. The amplitude of each radiated emission was measured on the OATS at a distance of 3 meters from the FSM antenna testing was performed on sample representative of production with integral antenna (sample #1) with worst-case data provided. The amplitude of each radiated emission was maximized by equipment orientation and placement on the turn table, raising and lowering the FSM (Field Strength Measuring) antenna, changing the FSM antenna polarization, and by rotating the turntable. A Loop antenna was used for measuring emissions from 0.009 to 30 MHz, Biconilog Antenna for 30 to 1000 MHz, Double-Ridge, and/or Pyramidal Horn Antennas from 1 GHz to 25 GHz. Emissions were measured in dB μ V/m @ 3 meters.

Refer to figures five through twenty-four showing plots taken of the 2402-2480 MHz transmitter operation displaying compliance with the specifications.

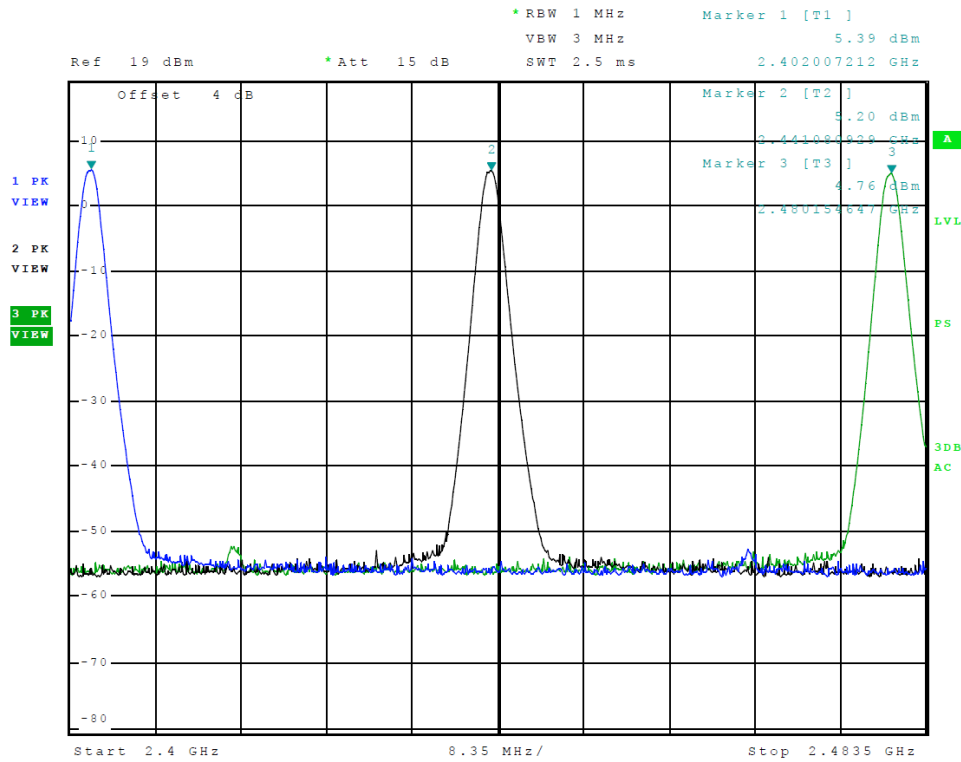

Figure 5 Plot of Transmitter Emissions Operation in 2402-2480 MHz ANT (GFSK)

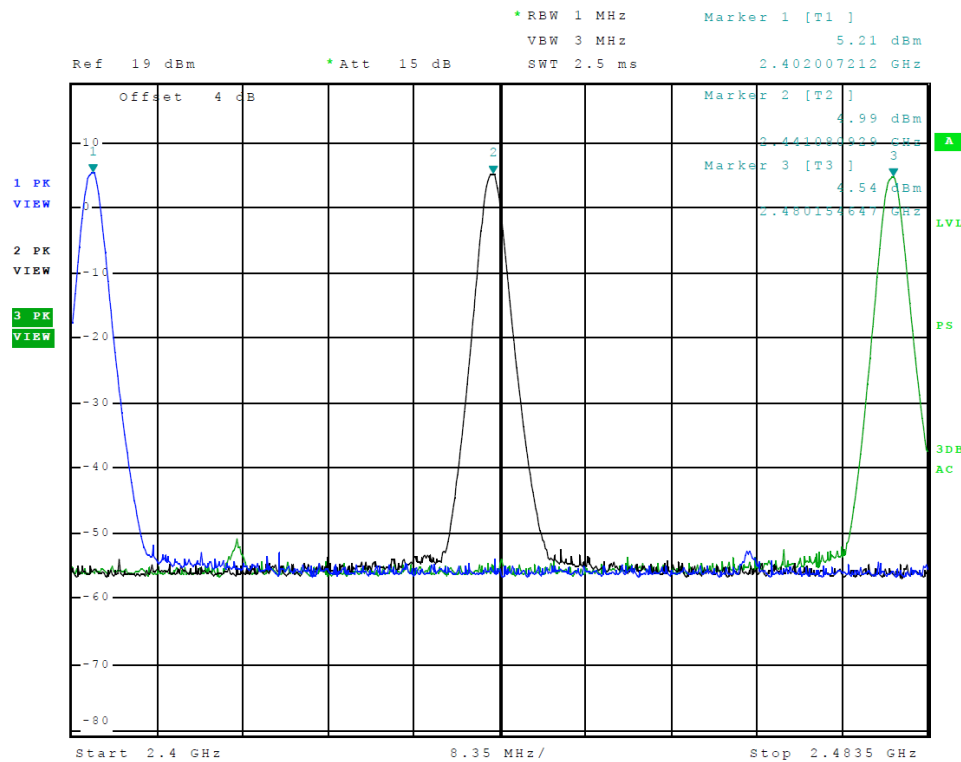

Figure 6 Plot of Transmitter Emissions Operation in 2402-2480 MHz BT BR (GFSK)

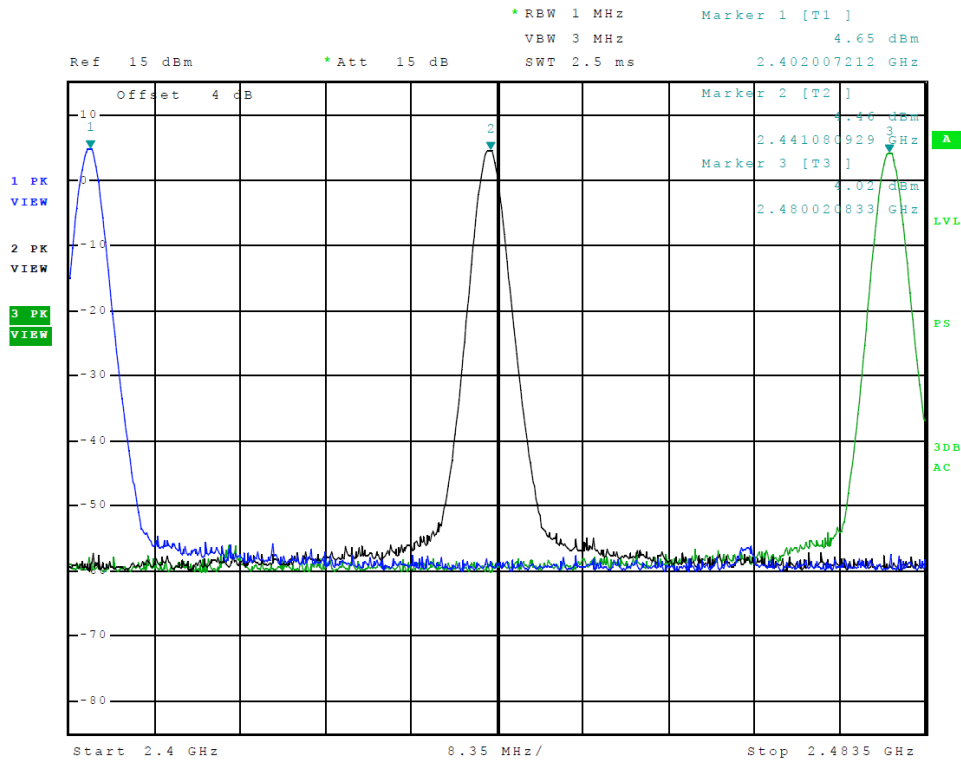

Figure 7 Plot of Transmitter Emissions Operation in 2402-2480 MHz 2EDR (PI/4 DPQSK)

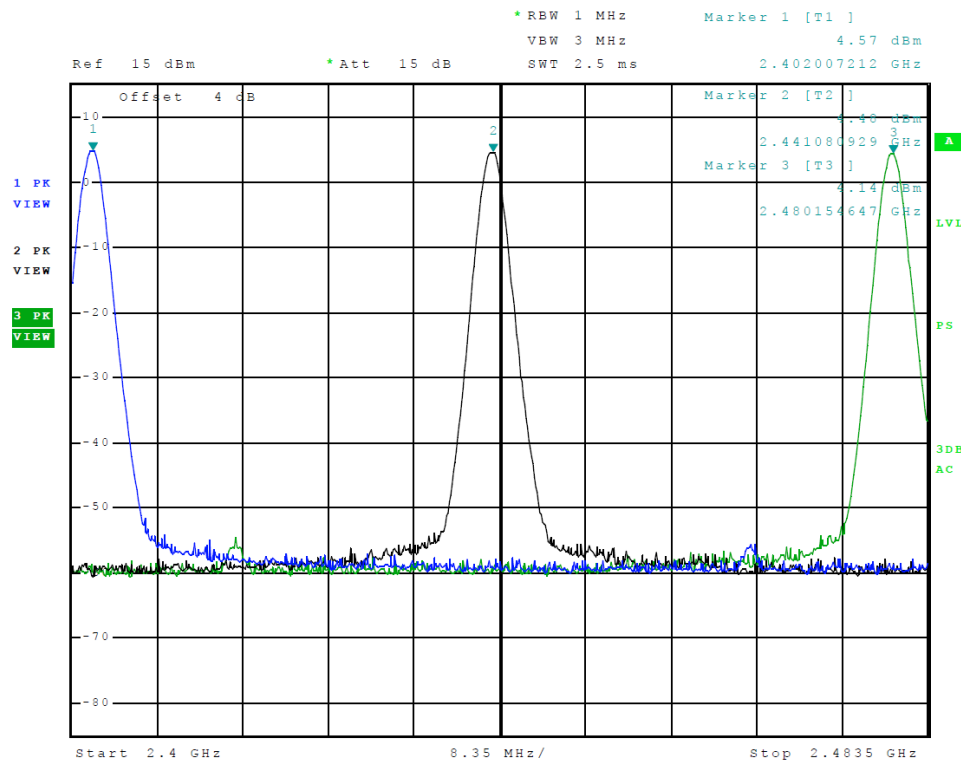

Figure 8 Plot of Transmitter Emissions Operation in 2402-2480 MHz 3EDR (8DPSK)

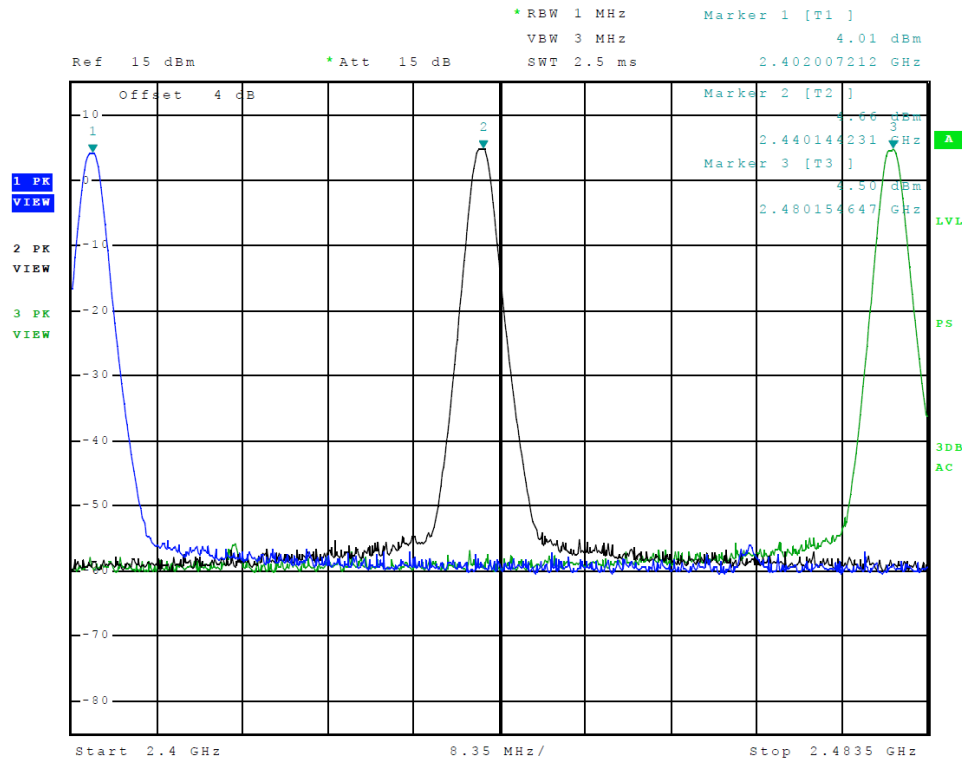

Figure 9 Plot of Transmitter Emissions Operation in 2402-2480 MHz BLE (GMSK)

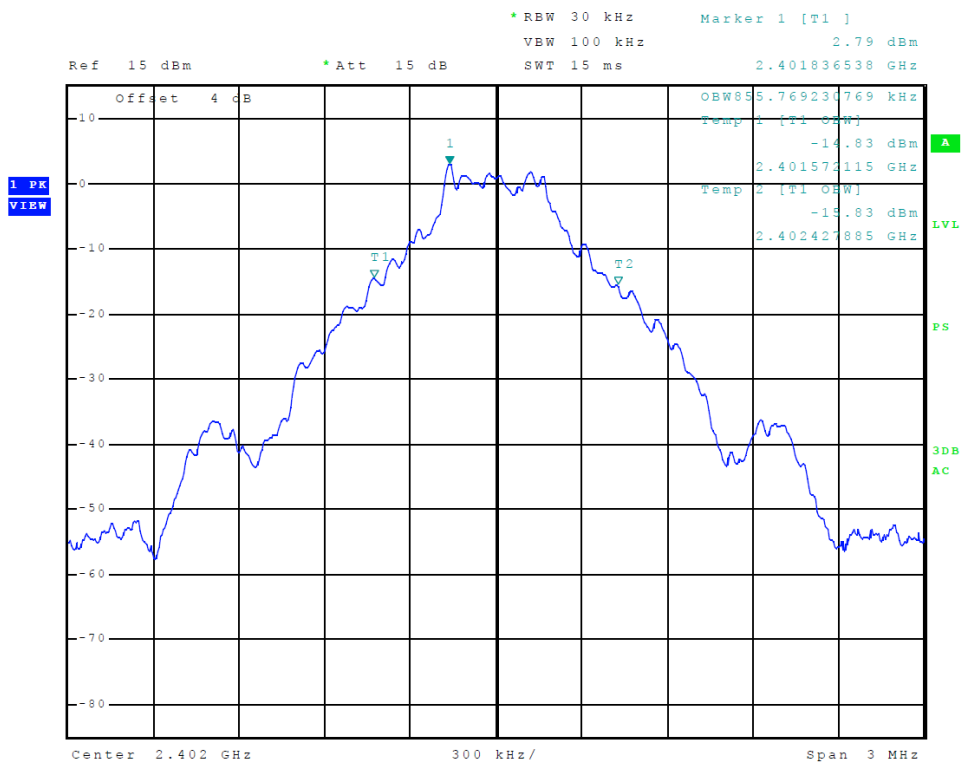

Figure 10 Plot of Transmitter Emissions 99% Occupied Bandwidth ANT (GFSK)

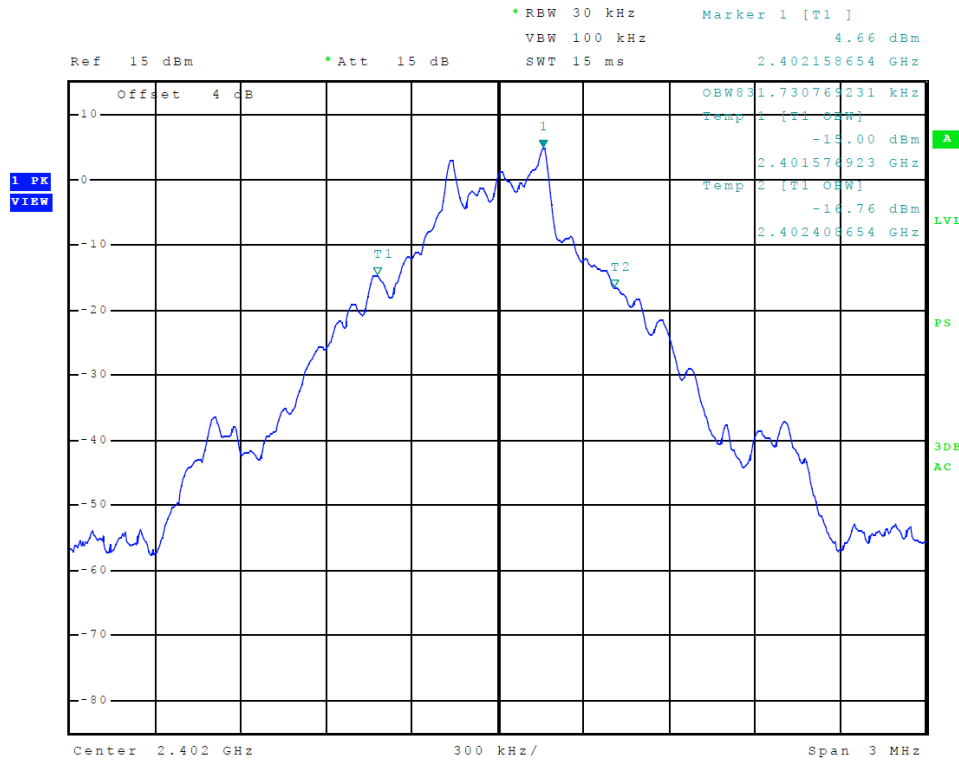

Figure 11 Plot of Transmitter Emissions 99% Occupied Bandwidth BT BR (GFSK)

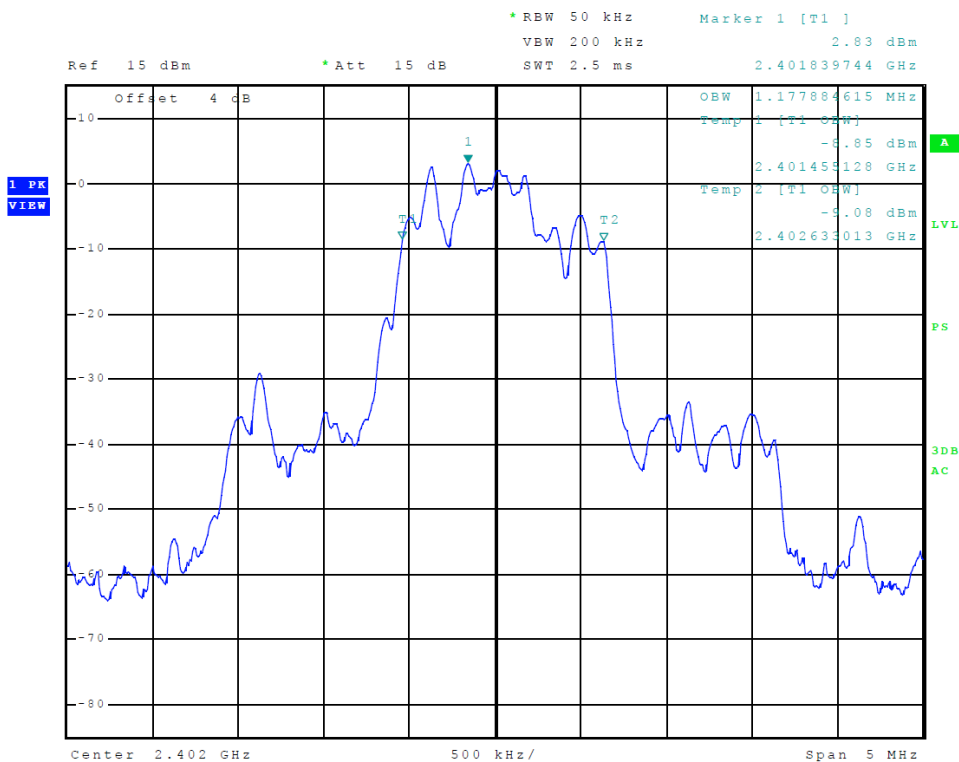

Figure 12 Plot of Transmitter Emissions 99% Occupied Bandwidth 2EDR (PI/4 DPQSK)

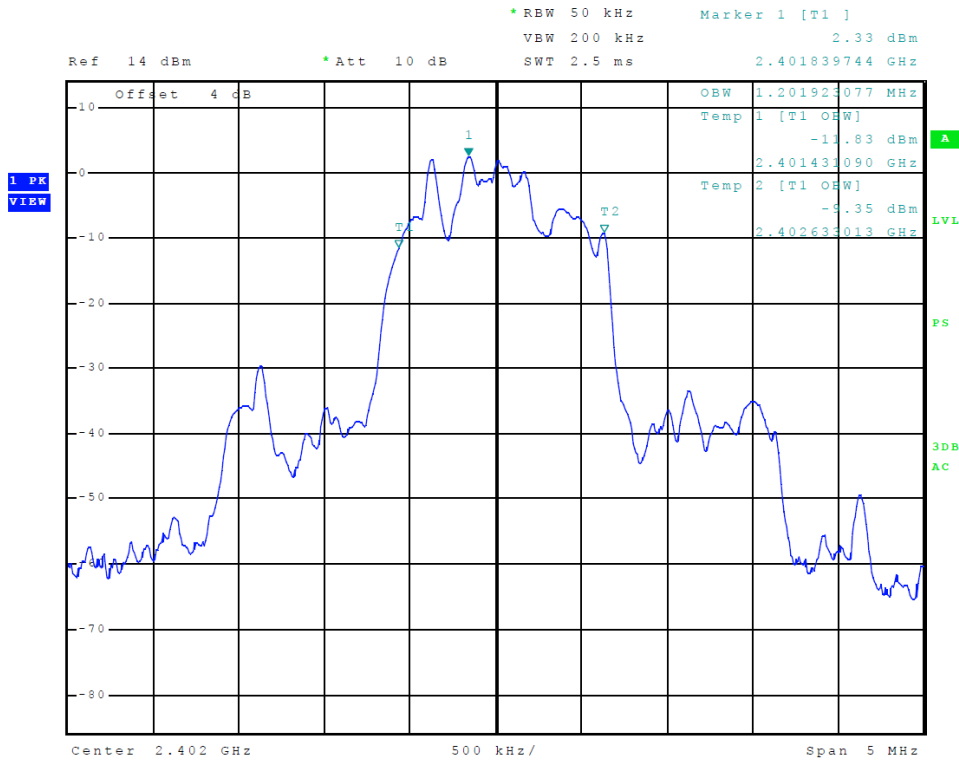

Figure 13 Plot of Transmitter Emissions 99% Occupied Bandwidth 3EDR (8DPSK)

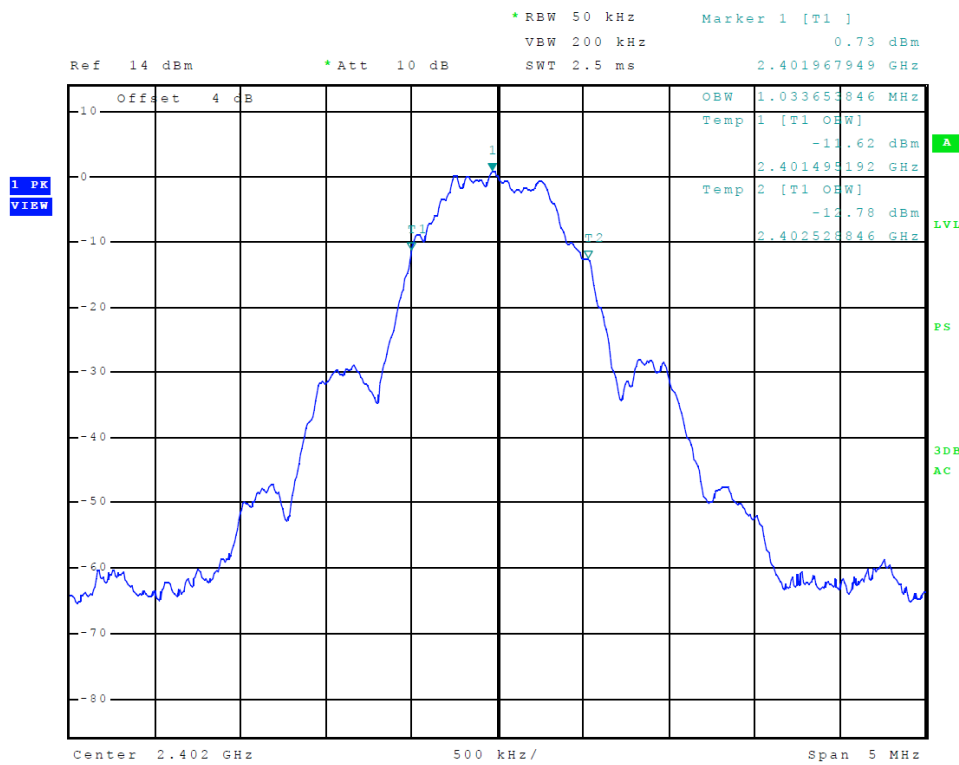

Figure 14 Plot of Transmitter Emissions 99% Occupied Bandwidth BLE (GMSK)

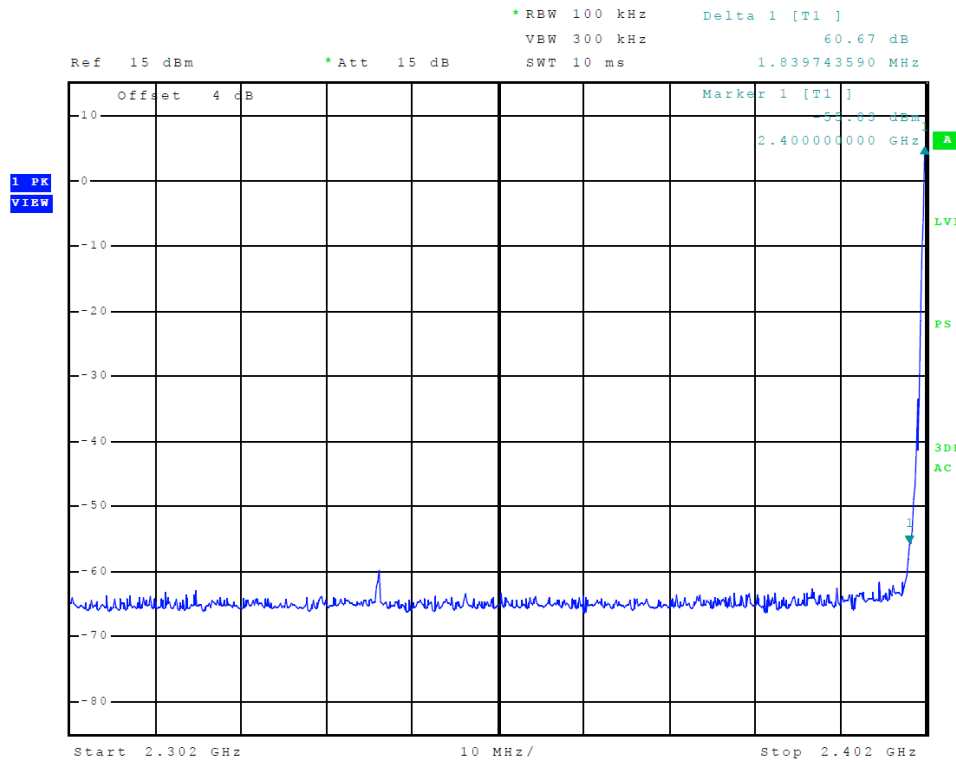

Figure 15 Plot of Transmitter Emissions Low Band Edge ANT (GFSK)

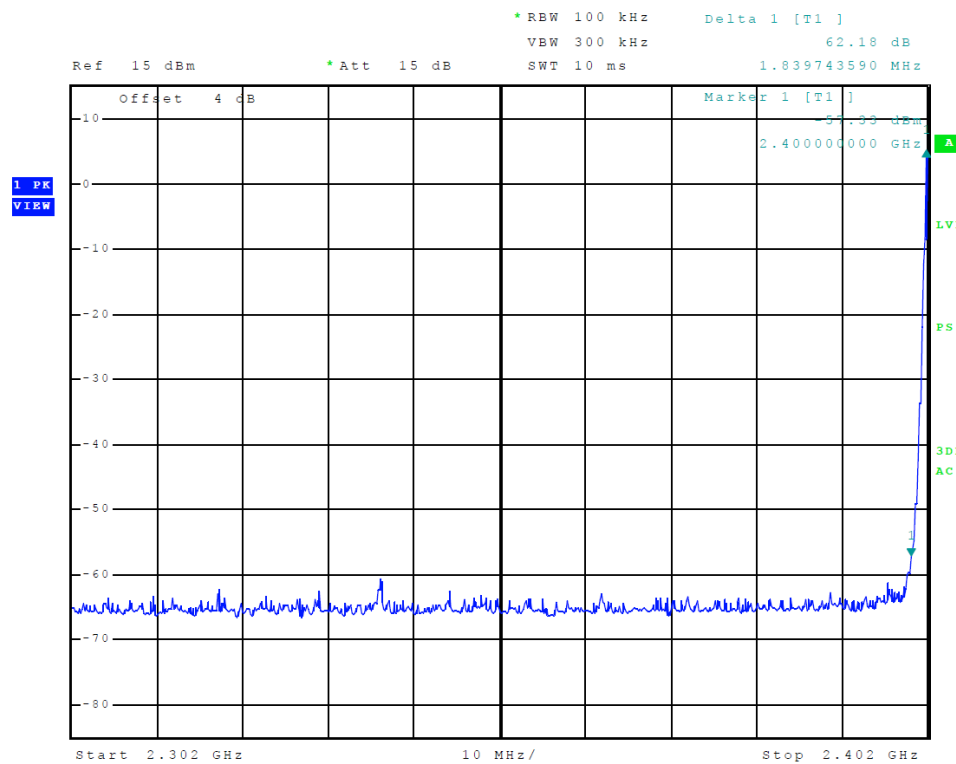

Figure 16 Plot of Transmitter Emissions Low Band Edge BT BR (GFSK)

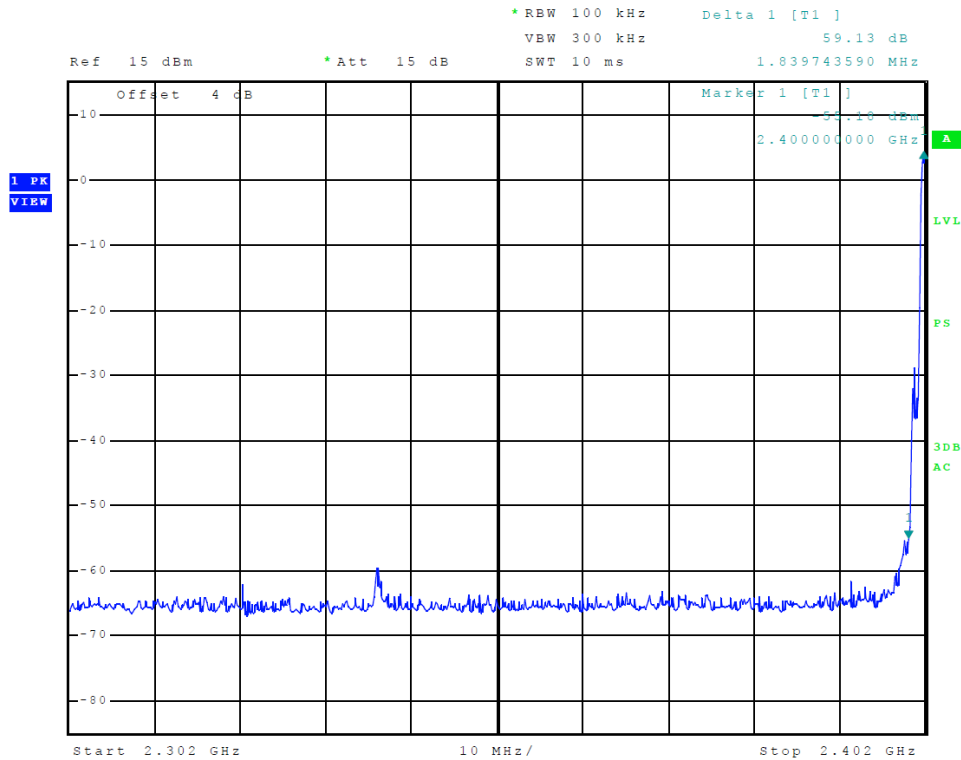

Figure 17 Plot of Transmitter Emissions Low Band Edge 2EDR (PI/4 DPQSK)

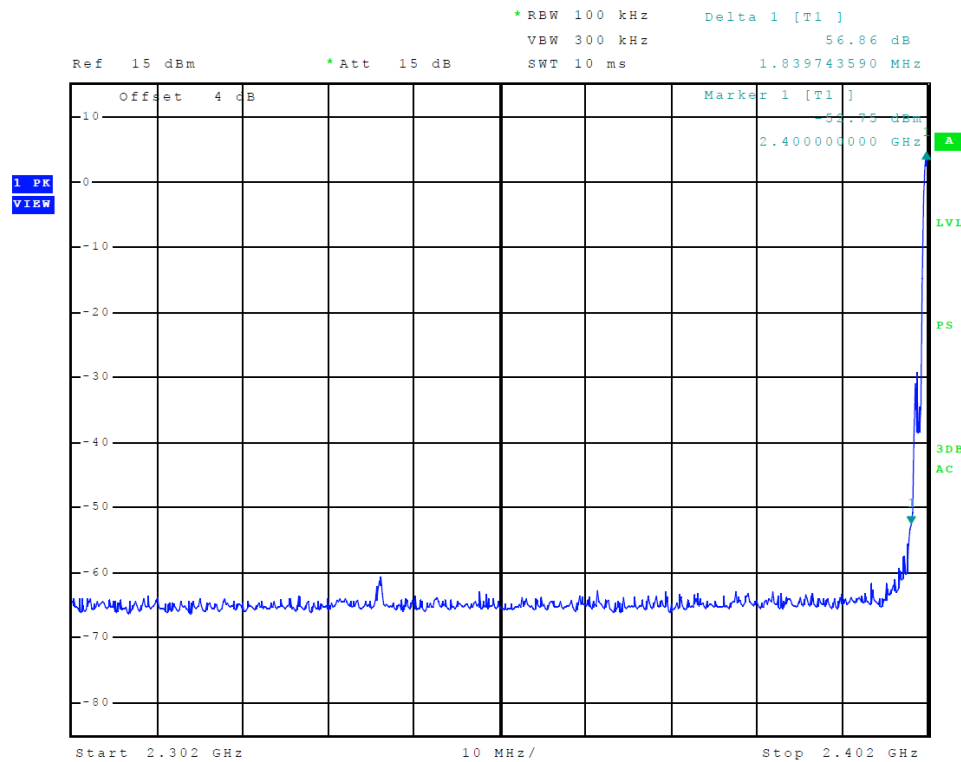

Figure 18 Plot of Transmitter Emissions Low Band Edge 3EDR (8DPSK)

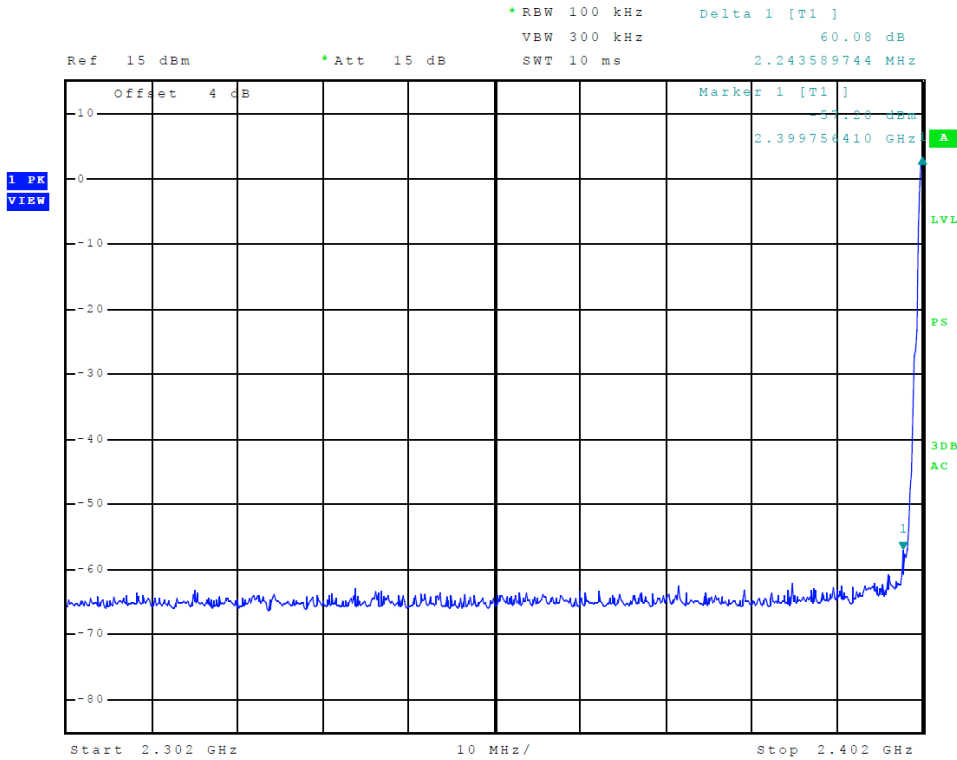

Figure 19 Plot of Transmitter Emissions Low Band Edge BLE (GMSK)

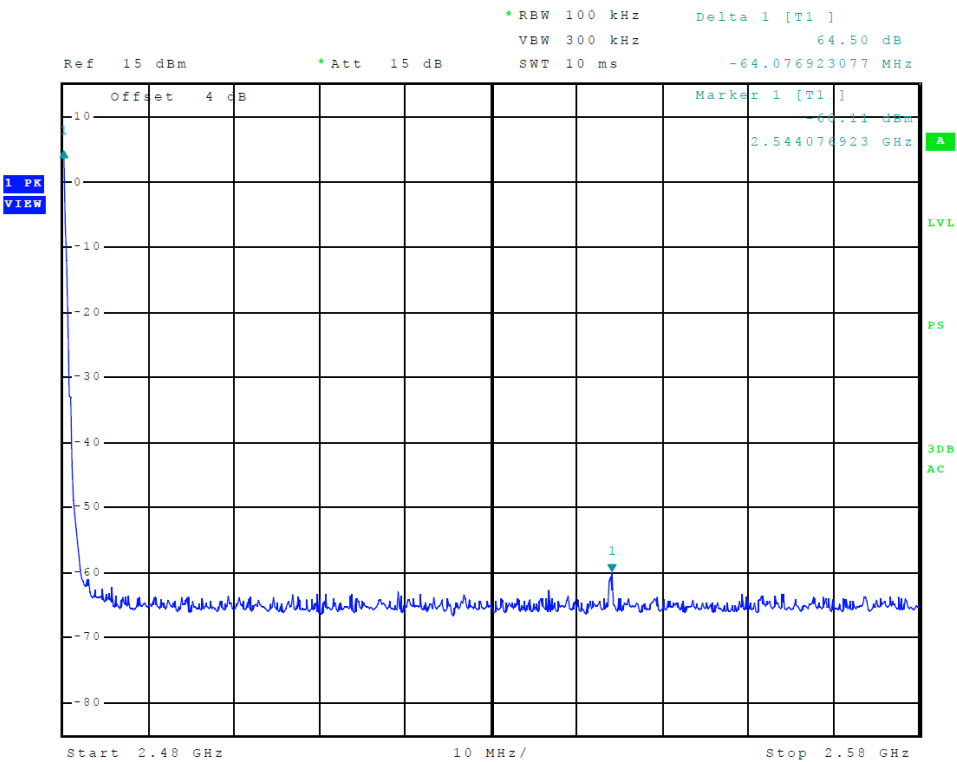

Figure 20 Plot of Transmitter Emissions High Band Edge ANT (GFSK)

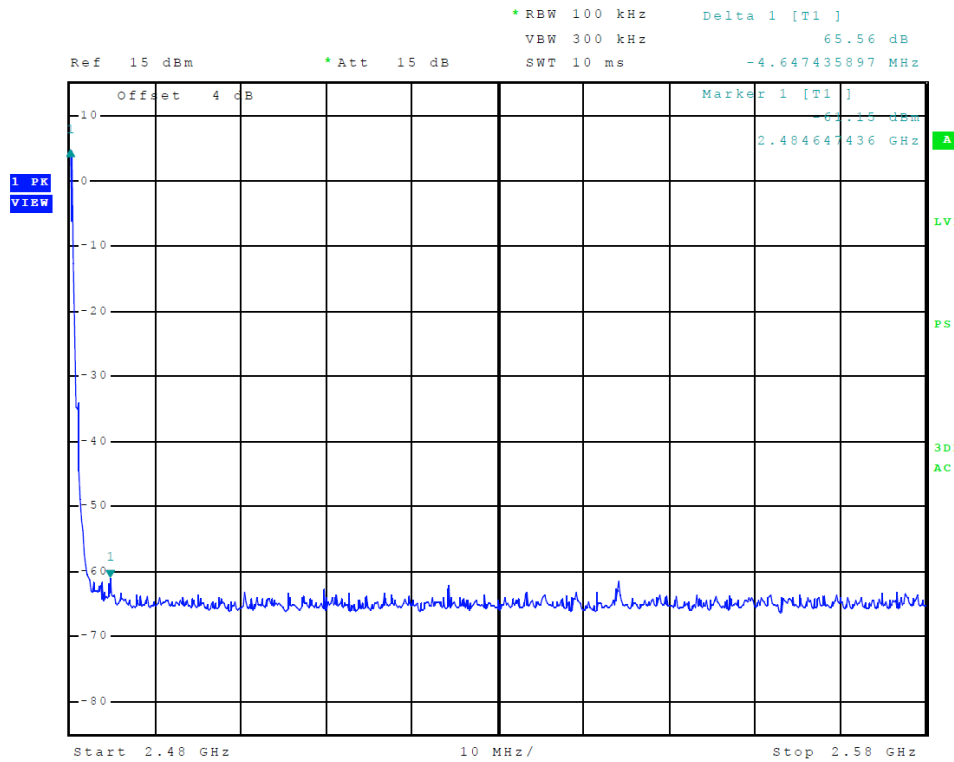

Figure 21 Plot of Transmitter Emissions High Band Edge BT BR (GFSK)

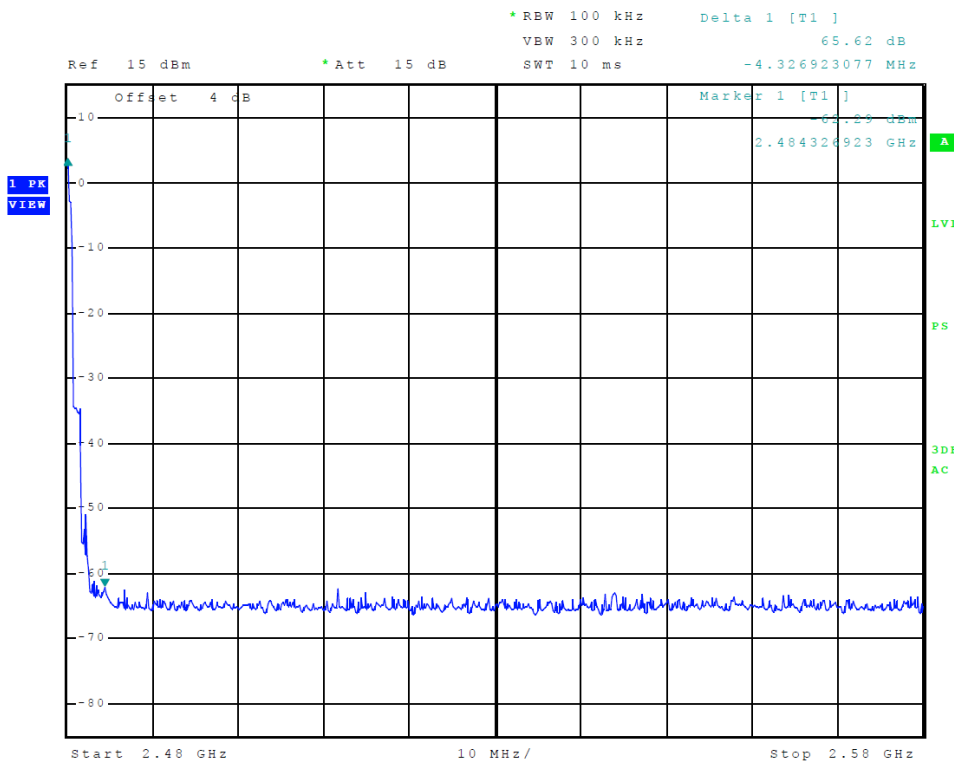

Figure 22 Plot of Transmitter Emissions High Band Edge 2EDR (PI/4 DPQSK)

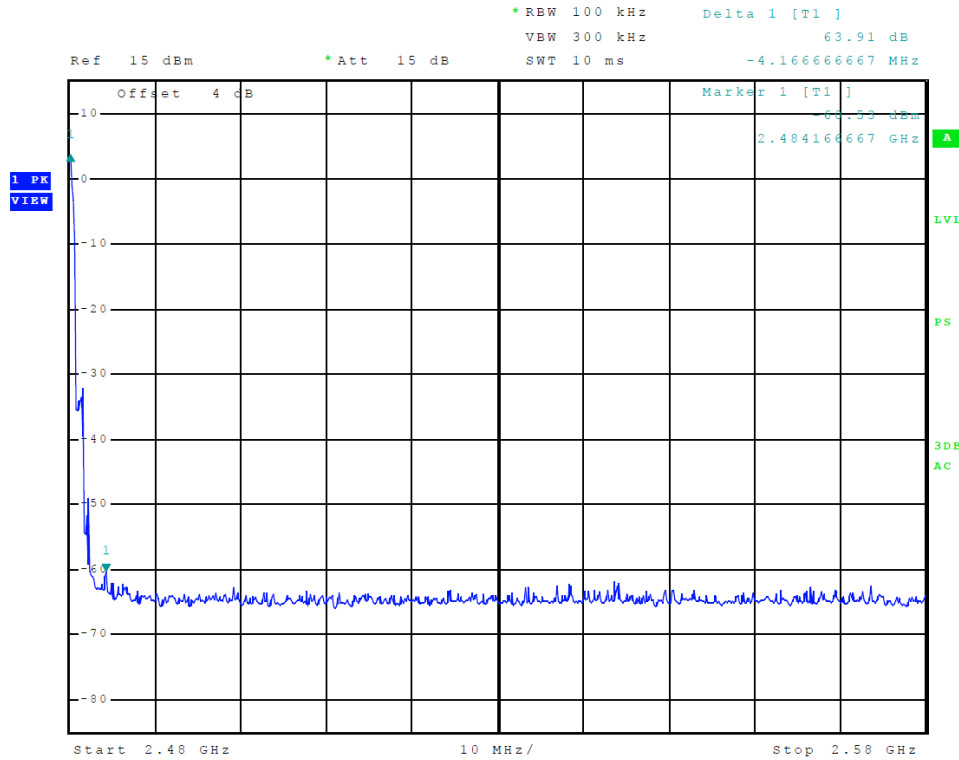

Figure 23 Plot of Transmitter Emissions High Band Edge 3EDR (8DPSK)

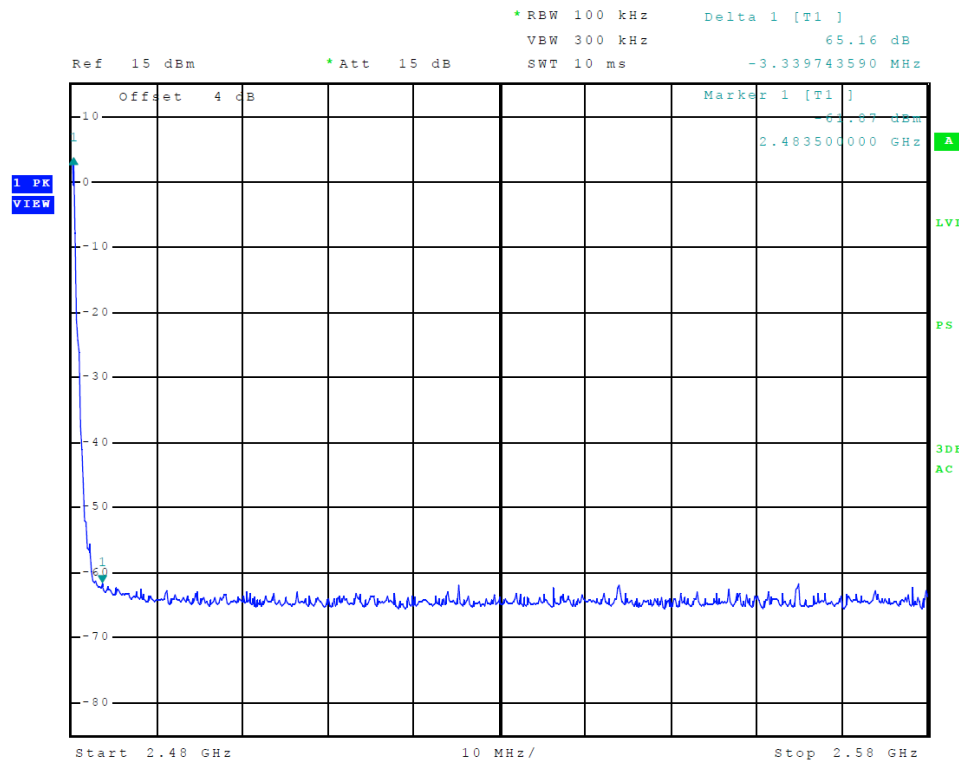

Figure 24 Plot of Transmitter Emissions High Band Edge BLE (GMSK)

Transmitter Emissions Data

Table 11 Transmitter Radiated Emissions ANT (GFSK)

Frequency in MHz	Horizontal Peak (dBµV/m)	Horizontal Quasi-Peak (dBµV/m)	Horizontal Average (dBµV/m)	Vertical Peak (dBµV/m)	Vertical Quasi-Peak (dBµV/m)	Vertical Average (dBµV/m)	Limit @ 3m (dBµV/m)
2402.0	95.6	N/A	84.0	98.8	N/A	87.4	94.0
4804.0	46.5	N/A	34.1	47.2	N/A	34.4	54.0
7206.0	51.1	N/A	38.1	51.1	N/A	38.1	54.0
9608.0	53.5	N/A	40.8	54.4	N/A	40.8	54.0
12010.0	55.8	N/A	43.2	56.2	N/A	43.1	54.0
14412.0	57.5	N/A	44.6	57.1	N/A	44.5	54.0
16814.0	63.1	N/A	50.4	63.7	N/A	50.4	54.0
2441.0	96.6	N/A	85.2	98.4	N/A	87.1	94.0
4882.0	47.5	N/A	34.7	47.6	N/A	34.6	54.0
7323.0	51.1	N/A	38.1	51.6	N/A	38.1	54.0
9764.0	53.2	N/A	40.5	53.7	N/A	40.4	54.0
12205.0	58.2	N/A	45.6	58.6	N/A	45.6	54.0
14646.0	59.0	N/A	46.5	59.3	N/A	46.5	54.0
17087.0	63.0	N/A	50.0	62.5	N/A	49.8	54.0
2480.0	94.6	N/A	83.6	96.8	N/A	85.7	94.0
4960.0	47.5	N/A	34.5	47.4	N/A	34.4	54.0
7440.0	51.2	N/A	37.6	50.5	N/A	37.5	54.0
9920.0	54.0	N/A	40.7	53.6	N/A	40.7	54.0
12400.0	57.8	N/A	44.9	57.8	N/A	44.9	54.0
14880.0	59.7	N/A	46.7	59.6	N/A	46.7	54.0
17360.0	60.4	N/A	47.9	60.6	N/A	47.9	54.0

Other emissions present had amplitudes at least 20 dB below the limit. Peak and Quasi-Peak amplitude emissions are recorded for frequency range below 1000 MHz. Peak and Average amplitude emissions are recorded for frequency range above 1000 MHz.

Table 12 Transmitter Radiated Emissions BT BR (GFSK)

Frequency in MHz	Horizontal Peak (dBμV/m)	Horizontal Quasi-Peak (dBμV/m)	Horizontal Average (dBμV/m)	Vertical Peak (dBμV/m)	Vertical Quasi-Peak (dBμV/m)	Vertical Average (dBμV/m)	Limit @ 3m (dBμV/m)
2402.0	97.0	N/A	85.7	98.9	N/A	87.6	94.0
4804.0	46.8	N/A	33.8	46.5	N/A	34.1	54.0
7206.0	50.4	N/A	38.1	50.9	N/A	38.1	54.0
9608.0	54.2	N/A	40.7	53.2	N/A	40.7	54.0
12010.0	56.8	N/A	43.2	55.7	N/A	43.0	54.0
14412.0	57.1	N/A	44.6	58.0	N/A	44.6	54.0
16814.0	63.2	N/A	50.6	63.6	N/A	50.6	54.0
2441.0	98.0	N/A	86.6	98.9	N/A	87.5	94.0
4882.0	47.8	N/A	34.5	47.5	N/A	34.5	54.0
7323.0	50.5	N/A	38.0	50.6	N/A	38.0	54.0
9764.0	53.5	N/A	40.5	53.9	N/A	40.5	54.0
12205.0	58.3	N/A	45.4	58.4	N/A	45.5	54.0
14646.0	59.0	N/A	46.4	59.6	N/A	46.4	54.0
17087.0	63.1	N/A	49.8	62.8	N/A	49.8	54.0
2480.0	95.4	N/A	84.2	97.3	N/A	86.1	94.0
4960.0	46.5	N/A	34.0	47.1	N/A	34.1	54.0
7440.0	50.4	N/A	37.5	50.5	N/A	37.5	54.0
9920.0	53.1	N/A	40.6	53.6	N/A	40.6	54.0
12400.0	57.6	N/A	44.8	58.6	N/A	44.8	54.0
14880.0	59.4	N/A	46.8	59.1	N/A	46.8	54.0
17360.0	60.8	N/A	47.9	60.9	N/A	47.9	54.0

Other emissions present had amplitudes at least 20 dB below the limit. Peak and Quasi-Peak amplitude emissions are recorded for frequency range below 1000 MHz. Peak and Average amplitude emissions are recorded for frequency range above 1000 MHz.

Table 13 Transmitter Radiated Emissions 2EDR (PI/4 DPQSK)

Frequency in MHz	Horizontal Peak (dBµV/m)	Horizontal Quasi-Peak (dBµV/m)	Horizontal Average (dBµV/m)	Vertical Peak (dBµV/m)	Vertical Quasi-Peak (dBµV/m)	Vertical Average (dBµV/m)	Limit @ 3m (dBµV/m)
2402.0	96.3	N/A	83.1	98.7	N/A	85.4	94.0
4804.0	46.8	N/A	33.5	47.1	N/A	34.1	54.0
7206.0	51.5	N/A	38.0	50.9	N/A	37.9	54.0
9608.0	53.8	N/A	40.7	53.4	N/A	40.7	54.0
12010.0	56.1	N/A	43.2	55.6	N/A	43.2	54.0
14412.0	58.1	N/A	44.7	57.7	N/A	44.7	54.0
16814.0	63.4	N/A	50.6	63.3	N/A	50.8	54.0
2441.0	95.7	N/A	82.7	98.5	N/A	85.1	94.0
4882.0	47.3	N/A	34.2	47.0	N/A	34.2	54.0
7323.0	50.3	N/A	38.0	51.0	N/A	37.9	54.0
9764.0	53.2	N/A	40.5	53.5	N/A	40.4	54.0
12205.0	58.1	N/A	45.4	58.6	N/A	45.4	54.0
14646.0	59.0	N/A	46.5	59.3	N/A	46.5	54.0
17087.0	62.6	N/A	49.5	62.6	N/A	49.6	54.0
2480.0	94.0	N/A	80.8	96.4	N/A	83.4	94.0
4960.0	47.2	N/A	34.7	47.6	N/A	34.4	54.0
7440.0	51.5	N/A	38.4	50.3	N/A	37.5	54.0
9920.0	54.0	N/A	40.7	53.8	N/A	40.8	54.0
12400.0	57.7	N/A	45.1	57.8	N/A	44.9	54.0
14880.0	60.4	N/A	46.9	59.4	N/A	46.8	54.0
17360.0	61.1	N/A	48.0	60.9	N/A	47.9	54.0

Other emissions present had amplitudes at least 20 dB below the limit. Peak and Quasi-Peak amplitude emissions are recorded for frequency range below 1000 MHz. Peak and Average amplitude emissions are recorded for frequency range above 1000 MHz.

Table 14 Transmitter Radiated Emissions 3EDR (8DPSK)

Frequency in MHz	Horizontal Peak (dB μ V/m)	Horizontal Quasi-Peak (dB μ V/m)	Horizontal Average (dB μ V/m)	Vertical Peak (dB μ V/m)	Vertical Quasi-Peak (dB μ V/m)	Vertical Average (dB μ V/m)	Limit @ 3m (dB μ V/m)
2402.0	96.0	N/A	82.5	98.5	N/A	85.3	94.0
4804.0	47.1	N/A	34.2	47.2	N/A	34.1	54.0
7206.0	51.6	N/A	38.0	50.6	N/A	38.0	54.0
9608.0	53.5	N/A	40.7	53.9	N/A	40.7	54.0
12010.0	56.1	N/A	43.2	55.7	N/A	43.0	54.0
14412.0	57.7	N/A	44.7	57.6	N/A	44.7	54.0
16814.0	63.7	N/A	50.8	63.8	N/A	50.6	54.0
2441.0	95.0	N/A	81.8	98.4	N/A	85.2	94.0
4882.0	47.2	N/A	34.2	48.4	N/A	35.2	54.0
7323.0	50.6	N/A	37.9	51.5	N/A	38.7	54.0
9764.0	53.3	N/A	40.5	53.4	N/A	40.6	54.0
12205.0	58.8	N/A	45.4	58.2	N/A	45.4	54.0
14646.0	59.7	N/A	46.5	59.4	N/A	46.6	54.0
17087.0	62.7	N/A	49.7	62.1	N/A	49.6	54.0
2480.0	92.6	N/A	79.6	96.3	N/A	83.2	94.0
4960.0	47.4	N/A	34.1	47.3	N/A	34.1	54.0
7440.0	50.2	N/A	37.4	50.1	N/A	37.4	54.0
9920.0	53.3	N/A	40.6	53.2	N/A	40.6	54.0
12400.0	58.1	N/A	44.9	57.5	N/A	44.9	54.0
14880.0	59.5	N/A	46.8	59.6	N/A	46.8	54.0
17360.0	60.6	N/A	48.0	61.3	N/A	48.0	54.0

Other emissions present had amplitudes at least 20 dB below the limit. Peak and Quasi-Peak amplitude emissions are recorded for frequency range below 1000 MHz. Peak and Average amplitude emissions are recorded for frequency range above 1000 MHz.

Table 15 Transmitter Radiated Emissions BLE (GMSK)

Frequency in MHz	Horizontal Peak (dBµV/m)	Horizontal Quasi-Peak (dBµV/m)	Horizontal Average (dBµV/m)	Vertical Peak (dBµV/m)	Vertical Quasi-Peak (dBµV/m)	Vertical Average (dBµV/m)	Limit @ 3m (dBµV/m)
2402.0	95.0	N/A	89.2	98.3	N/A	92.9	94.0
4804.0	46.8	N/A	33.9	47.2	N/A	34.2	54.0
7206.0	51.1	N/A	38.0	51.7	N/A	38.0	54.0
9608.0	53.0	N/A	40.7	53.5	N/A	40.7	54.0
12010.0	55.6	N/A	43.2	55.4	N/A	43.2	54.0
14412.0	57.8	N/A	44.8	57.6	N/A	44.9	54.0
16814.0	63.0	N/A	50.4	63.2	N/A	50.6	54.0
2440.0	95.1	N/A	89.4	98.8	N/A	93.1	94.0
4880.0	47.1	N/A	33.9	47.9	N/A	34.8	54.0
7320.0	50.7	N/A	38.0	51.0	N/A	37.9	54.0
9760.0	53.7	N/A	40.5	53.6	N/A	40.5	54.0
12200.0	57.7	N/A	45.2	58.1	N/A	45.2	54.0
14640.0	59.1	N/A	46.5	59.1	N/A	46.5	54.0
17080.0	62.3	N/A	49.7	62.5	N/A	49.8	54.0
2480.0	93.0	N/A	87.6	97.2	N/A	91.9	94.0
4960.0	47.7	N/A	34.3	47.1	N/A	34.5	54.0
7440.0	50.3	N/A	37.5	51.2	N/A	37.5	54.0
9920.0	53.2	N/A	40.7	53.6	N/A	40.7	54.0
12400.0	57.2	N/A	44.9	58.1	N/A	44.9	54.0
14880.0	59.7	N/A	46.8	59.3	N/A	46.7	54.0
17360.0	61.0	N/A	48.0	60.3	N/A	48.0	54.0

Other emissions present had amplitudes at least 20 dB below the limit. Peak and Quasi-Peak amplitude emissions are recorded for frequency range below 1000 MHz. Peak and Average amplitude emissions are recorded for frequency range above 1000 MHz.

Summary of Results for Transmitter Radiated Emissions of Intentional Radiator

The EUT demonstrated compliance with the radiated emissions requirements of FCC 47 CFR Part 15.249, Industry Canada RSS-210 Issue 9 and RSS-GEN Issue 5 Intentional Radiator regulations. The EUT worst-case test configuration demonstrated minimum average margin of -0.9 dB below the average emission limit for the fundamental. The EUT worst-case configuration demonstrated minimum radiated harmonic emission margin of -3.2 dB below the limit. Other emissions were present with amplitudes at least 20 dB below the limits.

Annex

- Annex A Measurement Uncertainty Calculations
- Annex B Additional Test Equipment
- Annex C Rogers Qualifications
- Annex D Rogers Labs Certificate of Accreditation

Annex A Measurement Uncertainty Calculations

The measurement uncertainty was calculated for all measurements listed in this test report according to CISPR 16-4. Result of measurement uncertainty calculations are recorded below. Component and process variability of production devices similar to those tested may result in additional deviations. The manufacturer has the sole responsibility of continued compliance.

Measurement	Expanded Measurement Uncertainty $U_{(lab)}$
3 Meter Horizontal 0.009-1000 MHz Measurements	4.16
3 Meter Vertical 0.009-1000 MHz Measurements	4.33
3 Meter Measurements 1-18 GHz	5.14
3 Meter Measurements 18-40 GHz	5.16
10 Meter Horizontal Measurements 0.009-1000 MHz	4.15
10 Meter Vertical Measurements 0.009-1000 MHz	4.32
AC Line Conducted	1.75
Antenna Port Conducted power	1.17
Frequency Stability	1.00E-11
Temperature	1.6°C
Humidity	3%

Annex B Additional Test Equipment

List of Test Equipment	Calibration	<u>Date (m/d/y)</u>	<u>Due</u>
Antenna: Schwarzbeck Model: BBA 9106/VHBB 9124 (9124-627)		5/2/2018	5/2/2019
Antenna: Schwarzbeck Model: VULP 9118 A (VULP 9118 A-534)		5/2/2018	5/2/2019
Antenna: EMCO 6509		10/16/2018	10/16/2020
Antenna: EMCO 3143 (9607-1277) 20-1200 MHz		5/2/2018	5/2/2019
Antenna: EMCO Dipole Set 3121C		2/23/2018	2/23/2019
Antenna: C.D. B-101		2/23/2018	2/23/2019
Antenna: Solar 9229-1 & 9230-1		2/23/2018	2/23/2019
Cable: Belden 8268 (L3)		10/16/2018	10/16/2019
Cable: Time Microwave: 4M-750HF290-750		10/16/2018	10/16/2019
Frequency Counter: Leader LDC-825 (8060153)		5/2/2018	5/2/2019
Oscilloscope Scope: Tektronix 2230		2/23/2018	2/23/2019
Wattmeter: Bird 43 with Load Bird 8085		2/23/2018	2/23/2019
R.F. Generator: SMB100A6 s/n 100623		5/2/2018	5/2/2019
R.F. Generator: SBMBV100A s/n: 260771		5/2/2018	5/2/2019
R.F. Generators: HP 606A, HP 8614A, HP 8640B		2/23/2018	2/23/2019
R.F. Power Amp 65W Model: 470-A-1010		2/23/2018	2/23/2019
R.F. Power Amp 50W M185- 10-501		2/23/2018	2/23/2019
R.F. Power Amp A.R. Model: 10W 1010M7		2/23/2018	2/23/2019
R.F. Power Amp EIN Model: A301		2/23/2018	2/23/2019
LISN: Compliance Eng. Model 240/20		5/2/2018	5/2/2019
LISN: Fischer Custom Communications Model: FCC-LISN-50-16-2-08		5/2/2018	5/2/2019
Audio Oscillator: H.P. 201CD		2/23/2018	2/23/2019
ESD Test Set 2010i		2/23/2018	2/23/2019
Oscilloscope Scope: Tektronix MDO 4104		2/23/2018	2/23/2019
EMC Transient Generator HVT TR 3000		2/23/2018	2/23/2019
AC Power Source (Ametek, California Instruments)		2/23/2018	2/23/2019
Fast Transient Burst Generator Model: EFT/B-101		2/23/2018	2/23/2019
Field Intensity Meter: EFM-018		2/23/2018	2/23/2019
KEYTEK Ecat Surge Generator		2/23/2018	2/23/2019
ESD Simulator: MZ-15		2/23/2018	2/23/2019
Shielded Room not required			

Rogers Labs, Inc.
4405 W. 259th Terrace
Louisburg, KS 66053
Phone/Fax: (913) 837-3214
Revision 1

Garmin International, Inc.
Model: A03485
Test #: 181015
Test to: CFR47 15.249, RSS-210, RSS-Gen
File: A03485 DXX TstRpt 181015

SN's: 88501 / 88605
FCC ID: IPH-03485
IC: 1792A-03485
Date: February 20, 2019
Page 47 of 49

Annex C Rogers Qualifications

Scot D. Rogers, Engineer

Rogers Labs, Inc.

Mr. Rogers has approximately 29 years' experience in the field of electronics. Engineering experience includes six years in the automated controls industry and remaining years working with the design, development and testing of radio communications and electronic equipment.

Positions Held

Systems Engineer: A/C Controls Mfg. Co., Inc. 6 Years

Electrical Engineer: Rogers Consulting Labs, Inc. 5 Years

Electrical Engineer: Rogers Labs, Inc. Current

Educational Background

- 1) Bachelor of Science Degree in Electrical Engineering from Kansas State University.
- 2) Bachelor of Science Degree in Business Administration Kansas State University.
- 3) Several Specialized Training courses and seminars pertaining to Microprocessors and Software programming.

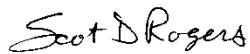

Scot D. Rogers

Annex D Rogers Labs Certificate of Accreditation

United States Department of Commerce
National Institute of Standards and Technology

NVLAP®

Certificate of Accreditation to ISO/IEC 17025:2005

NVLAP LAB CODE: 200087-0

Rogers Labs, Inc.
Louisburg, KS

*is accredited by the National Voluntary Laboratory Accreditation Program for specific services,
listed on the Scope of Accreditation, for:*

Electromagnetic Compatibility & Telecommunications

*This laboratory is accredited in accordance with the recognized International Standard ISO/IEC 17025:2005.
This accreditation demonstrates technical competence for a defined scope and the operation of a laboratory quality
management system (refer to joint ISO-ILAC-IAF Communiqué dated January 2009).*

2018-02-21 through 2019-03-31
Effective Dates



For the National Voluntary Laboratory Accreditation Program

Rogers Labs, Inc.
4405 W. 259th Terrace
Louisburg, KS 66053
Phone/Fax: (913) 837-3214
Revision 1

Garmin International, Inc.
Model: A03485
Test #: 181015
Test to: CFR47 15.249, RSS-210, RSS-Gen
File: A03485 DXX TstRpt 181015

SN's: 88501 / 88605
FCC ID: IPH-03485
IC: 1792A-03485
Date: February 20, 2019
Page 49 of 49