

Application For Grant of Certification

Model: A03322
2402-2480 MHz
47CFR 15.249 and RSS-210
Low Power Transmitter

FCC ID: IPH-03322
IC: 1792A-03322

FOR

Garmin International, Inc.

1200 East 151st Street
Olathe, KS 66062

FCC Designation: US5305
IC Test Site Registration: 3041A-1
Test Report Number: 171204

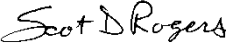
Authorized Signatory: 
Scot D. Rogers

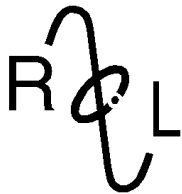

ROGERS LABS, INC.

4405 West 259th Terrace
Louisburg, KS 66053
Phone / Fax (913) 837-3214

Engineering Test Report For Grant of Certification Application

FOR
47 CFR, PART 15C - Intentional Radiators Paragraph 15.249 and
Industry Canada RSS-210 Issue 9, RSS-GEN Issue 4
License Exempt Intentional Radiator

For
Garmin International, Inc.

1200 East 151st Street
Olathe, KS 66062

Model: A03322

Low Power Transmitter

Frequency Range 2402-2480 MHz
FCC ID: IPH-03322
IC: 1792A-03322

Test Date: December 4, 2017

Certifying Engineer: *Scot D. Rogers*
Scot D. Rogers
Rogers Labs, Inc.
4405 West 259th Terrace
Louisburg, KS 66053
Telephone/Facsimile: (913) 837-3214

This report shall not be reproduced except in full, without the written approval of the laboratory.
This report must not be used by the client to claim product certification, approval, or
endorsement by NVLAP, NIST, or any agency of the Federal Government.

Rogers Labs, Inc.
4405 West 259th Terrace
Louisburg, KS 66053
Phone/Fax: (913) 837-3214
Revision 3

Garmin International, Inc.
Model: A03322
Test #: 171204
Test to: CFR47 15C, RSS-Gen, RSS-210
File: A03322 DXX TstRpt 171204 r3

SN's: 5HT000004 / 5HT000001
FCC ID: IPH-03322
IC: 1792A-03322
Date: April 24, 2018
Page 2 of 44

Table of Contents

| | |
|---------------------------------------------------------------------------------------------|-----------|
| TABLE OF CONTENTS..... | 3 |
| REVISIONS..... | 5 |
| FOREWORD..... | 6 |
| OPINION / INTERPRETATION OF RESULTS | 6 |
| EQUIPMENT TESTED..... | 6 |
| Equipment Function | 7 |
| Equipment Configuration..... | 8 |
| APPLICATION FOR CERTIFICATION..... | 9 |
| APPLICABLE STANDARDS & TEST PROCEDURES | 10 |
| EQUIPMENT TESTING PROCEDURES | 10 |
| AC Line Conducted Emission Test Procedure | 10 |
| Radiated Emission Test Procedure..... | 10 |
| Diagram 1 Test arrangement for Conducted emissions | 11 |
| Diagram 2 Test arrangement for radiated emissions of tabletop equipment..... | 12 |
| Diagram 3 Test arrangement for radiated emissions tested on Open Area Test Site (OATS)..... | 13 |
| TEST SITE LOCATIONS | 13 |
| LIST OF TEST EQUIPMENT | 14 |
| UNITS OF MEASUREMENTS | 15 |
| ENVIRONMENTAL CONDITIONS..... | 15 |
| STATEMENT OF MODIFICATIONS AND DEVIATIONS | 15 |
| INTENTIONAL RADIATORS..... | 15 |
| Antenna Requirements | 15 |
| Restricted Bands of Operation..... | 16 |

Table 1 Radiated Emissions in Restricted Frequency Bands Data (ANT Worst-case)..... 16

Table 2 Radiated Emissions in Restricted Frequency Bands Data (BT Worst-case)..... 18

Summary of Results for Radiated Emissions in Restricted Bands 18

AC Line Conducted Emissions Procedure 19

Figure 1 AC Line Conducted emissions of EUT line 1 (#2, EUT – Computer)..... 20

Figure 2 AC Line Conducted emissions of EUT line 2 (#2, EUT – Computer)..... 20

Figure 3 AC Line Conducted emissions of EUT line 1 (#4, EUT – AC Adapter)..... 21

Figure 4 AC Line Conducted emissions of EUT line 2 (#4, EUT – AC Adapter)..... 21

Figure 5 AC Line Conducted emissions of EUT line 1 (#5, EUT – AC Adapter)..... 22

Figure 6 AC Line Conducted emissions of EUT line 2 (#5, EUT – AC Adapter)..... 22

Table 3 AC Line Conducted Emissions Data L1 (#2, EUT – Computer)..... 23

Table 4 AC Line Conducted Emissions Data L2 (#2, EUT – Computer)..... 23

Table 5 AC Line Conducted Emissions Data L1 (#3, EUT – 362-00072-00) 24

Table 6 AC Line Conducted Emissions Data L2 (#3, EUT – 362-00072-00) 24

Table 7 AC Line Conducted Emissions Data L1 (#4, EUT – 362-00087-00) 25

Table 8 AC Line Conducted Emissions Data L2 (#3, EUT – 362-00087-00) 25

Summary of Results for AC Line Conducted Emissions Results 26

General Radiated Emissions Procedure 26

Table 9 General Radiated Emissions Data 27

Summary of Results for General Radiated Emissions 27

Operation in the Band 2400 – 2483.5 MHz 28

Figure 7 Plot of Transmitter Emissions (Operation in 2402-2480 MHz, ANT GFSK) 29

Figure 8 Plot of Transmitter Emissions (99% Occupied Bandwidth, ANT GFSK) 29

Figure 9 Plot of Transmitter Emissions (Low Band Edge, ANT GFSK) 30

Figure 10 Plot of Transmitter Emissions (High Band Edge, ANT GFSK) 30

Figure 11 Plot of Transmitter Emissions (Operation in 2402-2480 MHz, BT GFSK) 31

Figure 12 Plot of Transmitter Emissions (99% Occupied Bandwidth, BT GFSK) 31

Figure 13 Plot of Transmitter Emissions (Low Band Edge, BT GFSK) 32

Figure 14 Plot of Transmitter Emissions (High Band Edge, BT GFSK) 32

Figure 15 Plot of Transmitter Emissions (Operation in 2402-2480 MHz, BT 2EDR) 33

Figure 16 Plot of Transmitter Emissions (99% Occupied Bandwidth, BT 2EDR)..... 33

Figure 17 Plot of Transmitter Emissions (Low Band Edge, BT 2EDR)..... 34

Figure 18 Plot of Transmitter Emissions (High Band Edge, BT 2EDR)34
 Figure 19 Plot of Transmitter Emissions (Operation in 2402-2480 MHz, BT 3EDR)35
 Figure 20 Plot of Transmitter Emissions (99% Occupied Bandwidth, B BT 3EDR)35
 Figure 21 Plot of Transmitter Emissions (Low Band Edge, BT 3EDR).....36
 Figure 22 Plot of Transmitter Emissions (High Band Edge, BT 3EDR)36
Transmitter Emissions Data.....37
 Table 10 Transmitter Radiated Emissions (Worst-case) ANT37
 Table 11 Transmitter Radiated Emissions (Worst-case) BT38
Summary of Results for Transmitter Radiated Emissions of Intentional Radiator39
ANNEX..... 40
Annex A Measurement Uncertainty Calculations.....41
Annex B Rogers Labs Test Equipment List.....42
Annex C Rogers Qualifications43
Annex D Rogers Labs Certificate of Accreditation.....44

Revisions

Revision 3 Issued April 24, 2018 – corrected type error in Tables 5-8 (pages 24, 25), updated calibration dates in equipment list page 14
 Revision 2 Issued April 20, 2018 – corrected type error in Tables 5 and 6 (page 23), updated calibration dates in Annex B (page 41)
 Revision 1 Issued April 6, 2018

Foreword

The following information is submitted for consideration in obtaining Grant of Certification for low power intentional radiator per 47 CFR Paragraph 15.249, Industry Canada RSS-210 Issue 9 and RSS-GEN Issue 4, low power digital device transmitter operations in the 2400 – 2483.5 MHz frequency band.

Name of Applicant: Garmin International, Inc.
1200 East 151st Street
Olathe, KS 66062

M/N: A03322

FCC ID: IPH-03322 IC: 1792A-03322

Operating power: 2402-2480 MHz Maximum Average power ANT 92.1 dB μ V/m @ 3 meters, BT 92.1 dB μ V/m @ 3, (and peak 93.0 dB μ V/m @ 3 meters), [99% OBW, ANT 879.0 kHz, BT (GFSK) 879.0 kHz, BT (2EDR) 1240.0 kHz, BT (3EDR) 1250.0 kHz]

Opinion / Interpretation of Results

| Tests Performed | Margin (dB) | Results |
|---------------------------------------------------|-------------|----------|
| Restricted Bands 47CFR 15.205, RSS-210 2.2 | -16.9 | Complies |
| AC Line Conducted 47CFR 15.207, RSS-GEN 8.8 | -8.0 | Complies |
| Radiated Emissions 47CFR 15.209, RSS-GEN 8.9 | -25.1 | Complies |
| Harmonic Emissions per 47CFR 15.249, RSS-210 A2.9 | -12.8 | Complies |

Equipment Tested

| <u>Equipment</u> | <u>Model / PN</u> | <u>Serial Number</u> |
|---------------------|-------------------|----------------------|
| EUT #1 | A03322 | 5HT000004 |
| EUT #2 | A03322 | 5HT000001 |
| USB interface cable | 320-00559-00 | N/A |
| DC Adapter (CLA) | 013-00434-00 | N/A |
| AC/DC Adapter | 362-00072-00 | N/A |
| AC/DC Adapter | 362-00087-00 | N/A |
| Laptop Computer | Latitude E6320 | FCN03Q1 |
| USB Printer | Dell 0N5819 | 5D1SL61 |

Test results in this report relate only to the items tested.

Rogers Labs, Inc.
4405 West 259th Terrace
Louisburg, KS 66053
Phone/Fax: (913) 837-3214
Revision 3

Garmin International, Inc.
Model: A03322
Test #: 171204
Test to: CFR47 15C, RSS-Gen, RSS-210
File: A03322 DXX TstRpt 171204 r3

SN's: 5HT000004 / 5HT000001
FCC ID: IPH-03322
IC: 1792A-03322
Date: April 24, 2018
Page 6 of 44

Equipment Function

The EUT is a hand-held GPS receiver incorporating low power transceiver providing operation in the 2402-2480 MHz frequency band. The design also includes a 1600 MHz Satellite communications module (FCC ID: IPH-03302, IC: 1792A-03302) providing the ability to upload location information through satellite communications channels. The design provides 2.4 GHz wireless communications capabilities with compatible wireless equipment as well as providing the ability to send data through the satellite link. The 2.4 GHz transmitter operates in one of four modulation modes (ANT-GFSK, BT BR-GFSK, BT 2EDR-8DPSK, and BT 3EDR-PI/4-DPSK). The product operates from internal rechargeable battery only and provides micro USB interface connection port for use with power adapter or computer equipment. Recharge of internal battery is accomplished with the use of the USB interface cable that may be connected to compliant USB interface port, AC or DC adapter. The design utilizes internal fixed antenna system and offers no provision for antenna replacement or modification. Two samples were provided for testing, sample 1 representative of production design and sample 2 modified for testing purposes replacing integral antennas with RF connection ports. Test samples were provided with test software providing testing personnel the ability to enable transmitter function on defined channels and operational modes. The antenna modification offered testing facility ability to connect test equipment to the temporary antenna port for antenna port conducted emission testing. The EUT was arranged as described by the manufacturer for testing purposes. The EUT offers no other interface connections than those in the configuration options shown below as described by the manufacturer. For testing purposes, the EUT received power from freshly charged internal battery or external power and configured to operate in available modes. As requested by the manufacturer and required by regulations, the equipment was tested for emissions compliance using the available configurations with the worst-case data presented. Test results in this report relate only to the products described in this report.

Equipment Configuration

1. A03322 transmitting data through wireless 2.4 GHz communication (see test procedure document) and powered by internal battery.

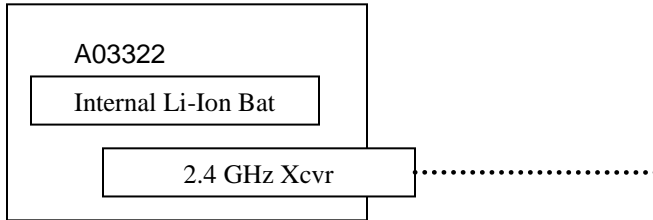

2. A03322 internal battery charged by PC through USB cable.

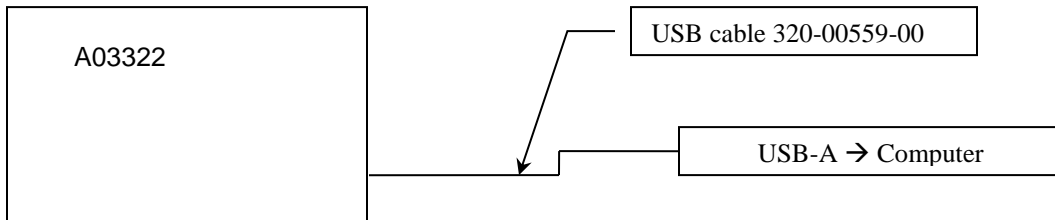

3. A03322 internal battery charged by CLA through USB cable.

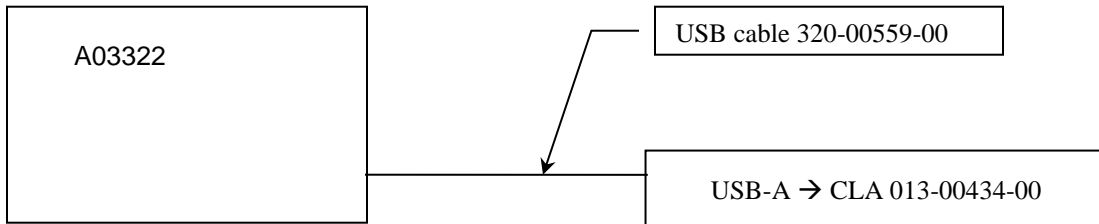

4. A03322 internal battery charged by AC adapter through USB cable.

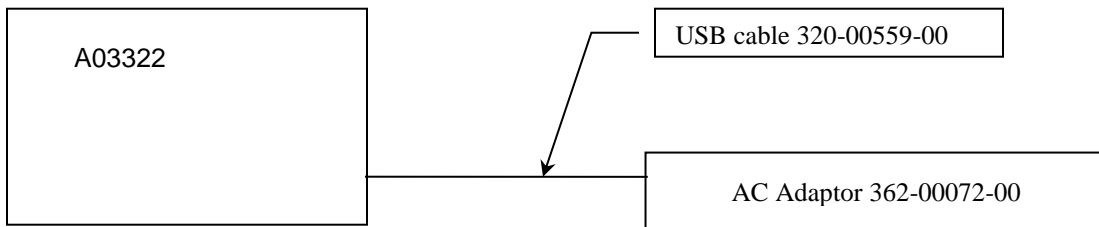

5. A03322 internal battery charged by AC adapter through USB cable.

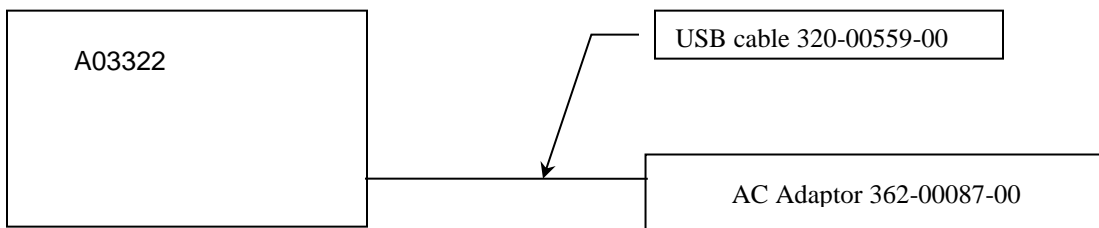

Application for Certification

- (1) Manufacturer: Garmin International, Inc.
1200 East 151st Street
Olathe, KS 66062
- (2) Identification: M/N: A03322
FCC ID: IPH-03322 IC: 1792A-03322
- (3) Instruction Book:
Refer to Exhibit for Instruction Manual.
- (4) Description of Circuit Functions:
Refer to Exhibit of Operational Description.
- (5) Block Diagram with Frequencies:
Refer to Exhibit of Operational Description.
- (6) Report of Measurements:
Report of measurements follows in this Report.
- (7) Photographs: Construction, Component Placement, etc.:
Refer to Exhibit for photographs of equipment.
- (8) List of Peripheral Equipment Necessary for operation. The equipment operates from direct current power provided from internal rechargeable battery. The design provides interface options with USB compliant equipment as presented in this filing. The EUT offers no other connection ports than those presented in this filing.
- (9) Transition Provisions of CFR47 15.37 are not requested.
- (10) Not Applicable. The unit is not a scanning receiver.
- (11) Not Applicable. The EUT does not operate in the 59 – 64 GHz frequency band.
- (12) The equipment is not software defined and this section is not applicable.
- (13) Applications for certification of U-NII devices in the 5.15-5.35 GHz and the 5.47-5.85 GHz bands must include a high-level operational description of the security procedures that control the radio frequency operating parameters and ensure that unauthorized modifications cannot be made. This requirement is not applicable to his DTS device.
- (14) Contain at least one drawing or photograph showing the test set-up for each of the required types of tests applicable to the device for which certification is requested. These drawings or photographs must show enough detail to confirm other information contained in the test report. Any photographs used must be focused originals without glare or dark spots and must clearly show the test configuration used. This information is provided in this report and Test Setup Exhibits provided with the application filing.

Applicable Standards & Test Procedures

In accordance with the e-CFR Code of Federal Regulations Title 47, dated December 4, 2017: Part 2, Subpart J, Paragraphs 2.907, 2.911, 2.913, 2.925, 2.926, 2.1031 through 2.1057, and applicable parts of paragraph 15, Part 15C Paragraph 15.249, Industry Canada RSS-210 issue 9, and RSS-GEN issue 4 operation in the 2400 – 2483.5 MHz Frequency band. Test procedures used are the established Methods of Measurement of Radio-Noise Emissions as described in ANSI C63.10-2013.

Equipment Testing Procedures

AC Line Conducted Emission Test Procedure

AC line-conducted emissions testing was performed as required in 47CFR 15C, RSS-210 and specified in ANSI C63.10-2013. The test setup, including the EUT, was arranged in the test configurations as presented during testing. The test configuration was placed on a 1 x 1.5-meter bench, 0.8 meters high located in a screen room. The power lines of the system were isolated from the power source using a standard LISN with a 50- μ Hy choke. EMI was coupled to the spectrum analyzer through a 0.1 μ F capacitor internal to the LISN. The LISN was positioned on the floor beneath the wooden bench supporting the EUT. The power lines and cables were draped over the back edge of the table. Refer to diagram one showing typical test arrangement and photographs in exhibits for EUT placement used during testing.

Radiated Emission Test Procedure

Radiated emissions testing was performed as required in 47CFR 15C, RSS-210 and specified in ANSI C63.10-2013. The EUT was placed on a rotating 0.9 x 1.2-meter platform, elevated as required above the ground plane at a distance of 3 meters from the FSM antenna. EMI energy was maximized by equipment placement permitting orientation in three orthogonal axes, raising and lowering the FSM antenna, changing the antenna polarization, and by rotating the turntable. Each emission was maximized before data was taken and recorded. The frequency spectrum from 9 kHz to 25,000 MHz was searched for emissions during preliminary investigation. Refer to diagrams two and three showing typical test setup. Refer to photographs in the test setup exhibits for specific EUT placement during testing.

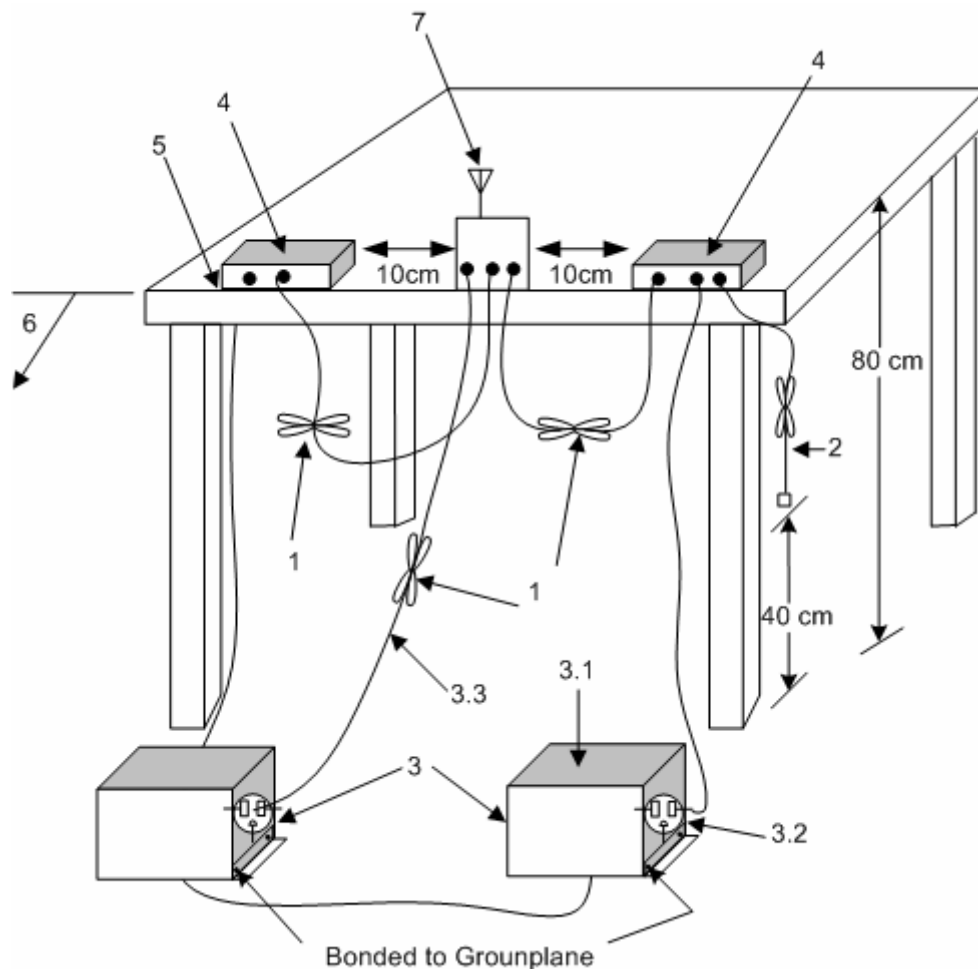

1. Interconnecting cables that hang closer than 40 cm to the ground plane shall be folded back and forth in the center forming a bundle 30 cm to 40 cm long see (see 6.2.3.1).
2. I/O cables that are not connected to an accessory shall be bundled in the center. The end of the cable may be terminated, if required, using the correct terminating impedance. The overall length shall not exceed 1 m (see 6.2.2).
3. EUT connected to one LISN. Unused LISN measuring port connectors shall be terminated in 50 Ω loads. LISN can be placed on top of, or immediately beneath, reference ground plane (see 6.2.2 and 6.2.3).
 - 3.1 All other equipment powered from additional LISN(s).
 - 3.2 Multiple-outlet strip can be used for multiple power cords of non-EUT equipment.
 - 3.3 LISN at least 80 cm from nearest part of EUT chassis.
4. Non-EUT components of EUT system being tested.
5. Rear of EUT, including peripherals, shall all be aligned and flush with rear of tabletop (see 6.2.3.1).
6. Edge of tabletop shall be 40 cm removed from a vertical conducting plane that is bonded to the ground plane (see 6.2.2 for options).
7. Antenna may be integral or detachable. If detachable, the antenna shall be attached for this test.

Diagram 1 Test arrangement for Conducted emissions

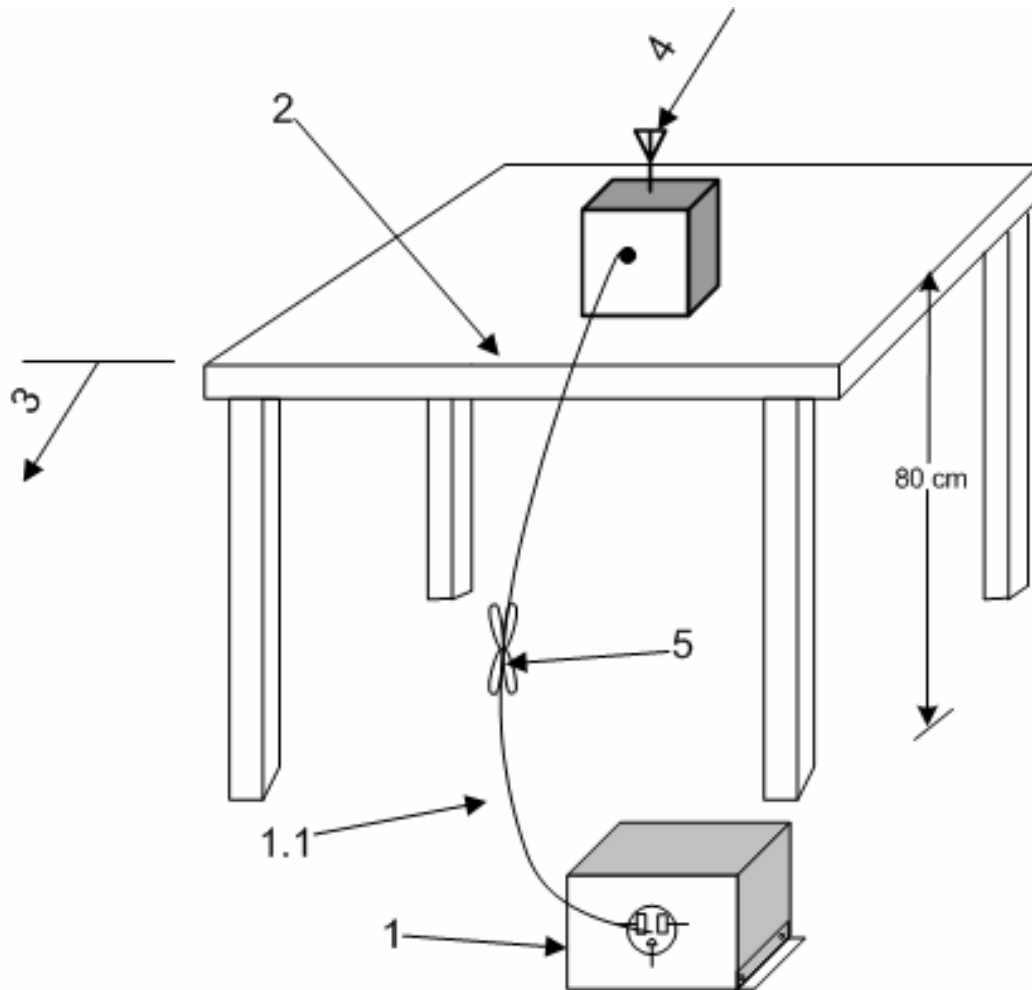

1—A LISN is optional for radiated measurements between 30 MHz and 1000 MHz but not allowed for measurements below 30 MHz and above 1000 MHz (see 6.3.1). If used, then connect EUT to one LISN. Unused LISN measuring port connectors shall be terminated in 50 Ω loads. The LISN may be placed on top of, or immediately beneath, the reference ground plane (see 6.2.2 and 6.2.3.2).

1.1—LISN spaced at least 80 cm from the nearest part of the EUT chassis.

2—Antenna can be integral or detachable, depending on the EUT (see 6.3.1).

3—Interconnecting cables that hang closer than 40 cm to the ground plane shall be folded back and forth in the center forming a bundle 30 cm to 40 cm long (see 6.3.1).

4—For emission measurements at or below 1 GHz, the table height shall be 80 cm. For emission measurements above 1 GHz, the table height shall be 1.5 m for measurements, except as otherwise specified (see 6.3.1 and 6.6.3.1).

Diagram 2 Test arrangement for radiated emissions of tabletop equipment

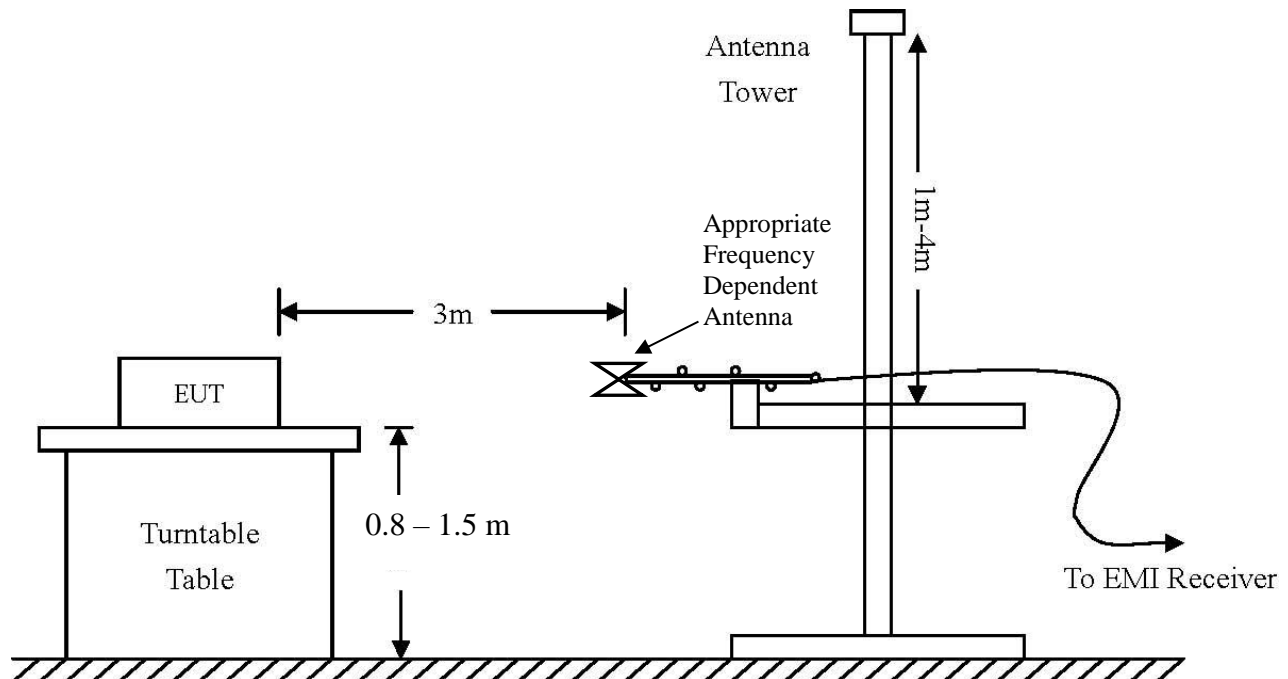

| AC Line Conducted Emissions (0.150 -30 MHz) | | |
|---------------------------------------------|----------|-------------------|
| RBW | AVG. BW | Detector Function |
| 9 kHz | 30 kHz | Peak / Quasi Peak |
| Emissions (30-1000 MHz) | | |
| RBW | AVG. BW | Detector Function |
| 120 kHz | 300 kHz | Peak / Quasi Peak |
| Emissions (Above 1000 MHz) | | |
| RBW | Video BW | Detector Function |
| 100 kHz | 100 kHz | Peak |
| 1 MHz | 1 MHz | Peak / Average |

Diagram 3 Test arrangement for radiated emissions tested on Open Area Test Site (OATS)

Test Site Locations

Conducted EMI The AC power line conducted emissions testing performed in a shielded screen room located at Rogers Labs, Inc., 4405 West 259th Terrace, Louisburg, KS

Radiated EMI The radiated emissions tests were performed at the 3 meters, Open Area Test Site (OATS) located at Rogers Labs, Inc., 4405 West 259th Terrace, Louisburg, KS

Site Registration Refer to Annex for Site Registration Letters

NVLAP Accreditation Lab code 200087-0

Rogers Labs, Inc.
4405 West 259th Terrace
Louisburg, KS 66053
Phone/Fax: (913) 837-3214
Revision 3

Garmin International, Inc.
Model: A03322
Test #: 171204
Test to: CFR47 15C, RSS-Gen, RSS-210
File: A03322 DXX TstRpt 171204 r3

SN's: 5HT000004 / 5HT000001
FCC ID: IPH-03322
IC: 1792A-03322
Date: April 24, 2018
Page 13 of 44

List of Test Equipment

| <u>Equipment</u> | <u>Manufacturer</u> | <u>Model (SN)</u> | <u>Band</u> | <u>Cal Date</u> | <u>Due</u> |
|-----------------------------------------------|---------------------|--------------------------------|--------------|-----------------|------------|
| <input checked="" type="checkbox"/> LISN | FCC | FCC-LISN-50-2-10(1PA) (160611) | .15-30MHz | 15/5/17 | 15/5/18 |
| <input checked="" type="checkbox"/> Cable | Huber & Suhner Inc. | Sucoflex102ea(L10M)(303073) | 9kHz-40 GHz | 24/10/17 | 24/10/18 |
| <input checked="" type="checkbox"/> Cable | Belden | RG-58 (L1-CAT3-11509) | 9kHz-30 MHz | 24/10/17 | 24/10/18 |
| <input checked="" type="checkbox"/> Cable | Belden | RG-58 (L2-CAT3-11509) | 9kHz-30 MHz | 24/10/17 | 24/10/18 |
| <input type="checkbox"/> Antenna | ARA | BCD-235-B (169) | 20-350MHz | 24/10/17 | 24/10/18 |
| <input type="checkbox"/> Antenna | EMCO | 3147 (40582) | 200-1000MHz | 24/10/17 | 24/10/18 |
| <input checked="" type="checkbox"/> Antenna | ETS-Lindgren | 3117 (200389) | 1-18 GHz | 15/5/17 | 15/5/18 |
| <input type="checkbox"/> Antenna | Com Power | AH-118 (10110) | 1-18 GHz | 24/10/17 | 24/10/19 |
| <input checked="" type="checkbox"/> Antenna | Com Power | AH-840 (101046) | 18-40 GHz | 15/5/17 | 15/5/19 |
| <input checked="" type="checkbox"/> Antenna | Com Power | AL-130 (121055) | .001-30 MHz | 24/10/17 | 24/10/18 |
| <input checked="" type="checkbox"/> Antenna | Sunol | JB-6 (A100709) | 30-1000 MHz | 24/10/17 | 24/10/18 |
| <input type="checkbox"/> Antenna | EMCO | 3143 (9607-1277) | 20-1200 MHz | 15/5/17 | 15/5/18 |
| <input checked="" type="checkbox"/> Analyzer | Rohde & Schwarz | ESU40 (100108) | 20Hz-40GHz | 15/5/17 | 15/5/18 |
| <input type="checkbox"/> Analyzer | Rohde & Schwarz | ESW44 (101534) | 20Hz-44GHz | 22/12/17 | 22/12/18 |
| <input type="checkbox"/> Analyzer | Rohde & Schwarz | FS-Z60, 90, 140, and 220 | 40GHz-220GHz | 22/12/17 | 22/12/19 |
| <input type="checkbox"/> Analyzer | HP | 8591EM (3628A00871) | 9kHz-1.8GHz | 15/5/17 | 15/5/18 |
| <input type="checkbox"/> Analyzer | HP | 8562A (3051A05950) | 9kHz-125GHz | 15/5/17 | 15/5/18 |
| <input type="checkbox"/> Analyzer | HP External Mixers | 11571, 11970 | 25GHz-110GHz | 15/5/17 | 15/5/18 |
| <input checked="" type="checkbox"/> Amplifier | Com-Power | PA-010 (171003) | 100Hz-30MHz | 24/10/17 | 24/10/18 |
| <input checked="" type="checkbox"/> Amplifier | Com-Power | CPPA-102 (01254) | 1-1000 MHz | 24/10/17 | 24/10/18 |
| <input checked="" type="checkbox"/> Amplifier | Com-Power | PAM-118A (551014) | 0.5-18 GHz | 24/10/17 | 24/10/18 |
| <input type="checkbox"/> Power Mtr | Agilent | N1911A with N1921A | 0.05-18 GHz | 15/5/17 | 15/5/18 |
| <input type="checkbox"/> Generator | Rohde & Schwarz | SMB100A6 (100150) | 20Hz-6 GHz | 15/5/17 | 15/5/18 |
| <input type="checkbox"/> Generator | Rohde & Schwarz | SMBV100A6 (260771) | 20Hz-6 GHz | 15/5/17 | 15/5/18 |
| <input type="checkbox"/> RF Filter | Micro-Tronics | BRC50722 (009).9G notch | 30-1800 MHz | 15/5/17 | 15/5/18 |
| <input type="checkbox"/> RF Filter | Micro-Tronics | HPM50114 (017)1.5G HPF | 30-18000 MHz | 15/5/17 | 15/5/18 |
| <input type="checkbox"/> RF Filter | Micro-Tronics | HPM50117 (063) 3G HPF | 30-18000 MHz | 15/5/17 | 15/5/18 |
| <input type="checkbox"/> RF Filter | Micro-Tronics | HPM50105 (059) 6G HPF | 30-18000 MHz | 15/5/17 | 15/5/18 |
| <input type="checkbox"/> RF Filter | Micro-Tronics | BRM50702 (172) 2G notch | 30-1800 MHz | 15/5/17 | 15/5/18 |
| <input type="checkbox"/> RF Filter | Micro-Tronics | BRC50703 (G102) 5G notch | 30-1800 MHz | 15/5/17 | 15/5/18 |
| <input type="checkbox"/> RF Filter | Micro-Tronics | BRC50705 (024) 5G notch | 30-1800 MHz | 15/5/17 | 15/5/18 |
| <input type="checkbox"/> RF Filter | Micro-Tronics | BRC17663 (001) 9G notch | 30-1800 MHz | 15/5/17 | 15/5/18 |
| <input type="checkbox"/> Attenuator | Fairview | SA6NFN100W-14 (1625) | 30-1800 MHz | 15/5/17 | 15/5/18 |
| <input type="checkbox"/> Attenuator | Mini-Circuits | VAT-3W2+ (1735) | 30-6000 MHz | 15/5/17 | 15/5/18 |
| <input type="checkbox"/> Attenuator | Mini-Circuits | VAT-3W2+ (1436) | 30-6000 MHz | 15/5/17 | 15/5/18 |
| <input type="checkbox"/> Attenuator | Mini-Circuits | VAT-3W2+ (14362) | 30-6000 MHz | 15/5/17 | 15/5/18 |
| <input type="checkbox"/> Attenuator | Mini-Circuits | VAT-3W2+ (1445) | 30-6000 MHz | 15/5/17 | 15/5/18 |
| <input type="checkbox"/> Attenuator | Mini-Circuits | VAT-3W2+ (14452) | 30-6000 MHz | 15/5/17 | 15/5/18 |
| <input type="checkbox"/> Attenuator | Mini-Circuits | VAT-6W2+ (1438) | 30-6000 MHz | 15/5/17 | 15/5/18 |
| <input type="checkbox"/> Attenuator | Mini-Circuits | VAT-6W2+ (1736) | 30-6000 MHz | 15/5/17 | 15/5/18 |

Rogers Labs, Inc.
4405 West 259th Terrace
Louisburg, KS 66053
Phone/Fax: (913) 837-3214
Revision 3

Garmin International, Inc.
Model: A03322
Test #: 171204
Test to: CFR47 15C, RSS-Gen, RSS-210
File: A03322 DXX TstRpt 171204 r3

SN's: 5HT000004 / 5HT000001
FCC ID: IPH-03322
IC: 1792A-03322
Date: April 24, 2018
Page 14 of 44

Units of Measurements

Conducted EMI Data is in dB μ V; dB referenced to one microvolt

Radiated EMI Data is in dB μ V/m; dB/m referenced to one microvolt per meter

Sample Calculation:

RFS = Radiated Field Strength, FSM = Field Strength Measured

A.F. = Receive antenna factor, Gain = amplification gains and/or cable losses

RFS (dB μ V/m @ 3m) = FSM (dB μ V) + A.F. (dB) - Gain (dB)

Environmental Conditions

Ambient Temperature 23.1° C

Relative Humidity 45%

Atmospheric Pressure 1001.1 mb

Statement of Modifications and Deviations

No modifications to the EUT were required for the equipment to demonstrate compliance with the CFR47 Part 15C, Industry Canada RSS-210 Issue 9, and RSS-GEN emission requirements. There were no deviations to the specifications.

Intentional Radiators

The following information is submitted in support demonstration of compliance with the requirements of 47CFR, Subpart C, paragraph 15.249, Industry Canada RSS-210 Issue 9 and RSS-GEN Issue 4.

Antenna Requirements

The EUT incorporates integral antenna system. Production equipment offers no provision for connection to alternate antenna system. The antenna connection point complies with the unique antenna connection requirements. There are no deviations or exceptions to the specification.

Restricted Bands of Operation

Spurious emissions falling in the restricted frequency bands of operation were measured at the OATS. The EUT utilizes frequency, determining circuitry, which generates harmonics falling in the restricted bands. Emissions were investigated at the OATS, using appropriate antennas or pyramidal horns, amplification stages, and a spectrum analyzer. Peak and average amplitudes of frequencies above 1000 MHz were compared to the required limits with worst-case data presented below. Test procedures of ANSI C63.10-2013 were used during testing. No other significant emission was observed which fell into the restricted bands of operation. Computed emission values take into account the received radiated field strength, receive antenna correction factor, amplifier gain stage, and test system cable losses.

Table 1 Radiated Emissions in Restricted Frequency Bands Data (ANT Worst-case)

| Frequency in MHz | Horizontal Peak (dBμV/m) | Horizontal Quasi-Peak (dBμV/m) | Horizontal Average (dBμV/m) | Vertical Peak (dBμV/m) | Vertical Quasi-Peak (dBμV/m) | Vertical Average (dBμV/m) | Limit @ 3m (dBμV/m) |
|------------------|--------------------------|--------------------------------|-----------------------------|------------------------|------------------------------|---------------------------|---------------------|
| 2390.0 | 40.7 | N/A | 28.0 | 46.1 | N/A | 28.2 | 54.0 |
| 2483.5 | 41.5 | N/A | 28.7 | 41.6 | N/A | 28.9 | 54.0 |
| 4804.0 | 44.0 | N/A | 31.0 | 44.3 | N/A | 31.0 | 54.0 |
| 4882.0 | 44.3 | N/A | 31.1 | 43.8 | N/A | 31.0 | 54.0 |
| 4960.0 | 44.9 | N/A | 33.0 | 44.2 | N/A | 31.2 | 54.0 |
| 7206.0 | 44.4 | N/A | 33.3 | 45.7 | N/A | 33.0 | 54.0 |
| 7323.0 | 46.0 | N/A | 32.4 | 45.7 | N/A | 32.5 | 54.0 |
| 7440.0 | 45.4 | N/A | 32.9 | 46.1 | N/A | 33.0 | 54.0 |
| 12010.0 | 47.9 | N/A | 36.0 | 48.3 | N/A | 35.5 | 54.0 |
| 12205.0 | 49.6 | N/A | 36.6 | 49.5 | N/A | 36.9 | 54.0 |
| 12400.0 | 50.1 | N/A | 36.8 | 50.2 | N/A | 37.1 | 54.0 |

Other emissions present had amplitudes at least 20 dB below the limit. Peak and Quasi-Peak amplitude emissions are recorded for frequency range below 1000 MHz. Peak and Average amplitude emissions are recorded for frequency range above 1000 MHz.

Rogers Labs, Inc.
4405 West 259th Terrace
Louisburg, KS 66053
Phone/Fax: (913) 837-3214
Revision 3

Garmin International, Inc.
Model: A03322
Test #: 171204
Test to: CFR47 15C, RSS-Gen, RSS-210
File: A03322 DXX TstRpt 171204 r3

SN's: 5HT000004 / 5HT000001
FCC ID: IPH-03322
IC: 1792A-03322
Date: April 24, 2018
Page 17 of 44

Table 2 Radiated Emissions in Restricted Frequency Bands Data (BT Worst-case)

| Frequency in MHz | Horizontal Peak (dB μ V/m) | Horizontal Quasi-Peak (dB μ V/m) | Horizontal Average (dB μ V/m) | Vertical Peak (dB μ V/m) | Vertical Quasi-Peak (dB μ V/m) | Vertical Average (dB μ V/m) | Limit @ 3m (dB μ V/m) |
|------------------|--------------------------------|--------------------------------------|-----------------------------------|------------------------------|------------------------------------|---------------------------------|---------------------------|
| 2390.0 | 41.4 | N/A | 28.6 | 46.8 | N/A | 28.5 | 54.0 |
| 2483.5 | 41.9 | N/A | 28.6 | 41.6 | N/A | 28.9 | 54.0 |
| 4804.0 | 43.7 | N/A | 31.0 | 44.3 | N/A | 31.0 | 54.0 |
| 4880.0 | 43.8 | N/A | 30.9 | 43.5 | N/A | 30.6 | 54.0 |
| 4960.0 | 44.5 | N/A | 31.5 | 44.5 | N/A | 31.4 | 54.0 |
| 7206.0 | 46.4 | N/A | 33.3 | 45.7 | N/A | 33.0 | 54.0 |
| 7320.0 | 44.4 | N/A | 31.9 | 45.1 | N/A | 32.2 | 54.0 |
| 7440.0 | 45.7 | N/A | 32.1 | 45.9 | N/A | 32.8 | 54.0 |
| 12010.0 | 49.0 | N/A | 36.0 | 48.3 | N/A | 35.5 | 54.0 |
| 12200.0 | 49.6 | N/A | 36.8 | 50.1 | N/A | 37.1 | 54.0 |
| 12400.0 | 50.1 | N/A | 36.6 | 49.9 | N/A | 36.8 | 54.0 |

Other emissions present had amplitudes at least 20 dB below the limit. Peak and Quasi-Peak amplitude emissions are recorded for frequency range below 1000 MHz. Peak and Average amplitude emissions are recorded for frequency range above 1000 MHz.

Summary of Results for Radiated Emissions in Restricted Bands

The EUT demonstrated compliance with the radiated emissions requirements of 47CFR Part 15C and RSS-210 Intentional Radiator requirements. The EUT ANT mode demonstrated a worst-case minimum margin of -16.9 dB below the emissions requirements in restricted frequency bands. The EUT worst-case BT mode demonstrated a worst-case minimum margin of -16.9 dB below the emissions requirements in restricted frequency bands. Peak, Quasi-peak, and average amplitudes were checked for compliance with the regulations. Worst-case emissions are reported with other emissions found in the restricted frequency bands at least 20 dB below the requirements.

AC Line Conducted Emissions Procedure

The EUT was arranged in typical equipment configurations operating from AC power adapter. Testing was performed with the EUT placed on a 1 x 1.5-meter wooden bench 80 cm above the conducting ground plane, floor of a screen room. The bench was positioned 40 cm away from the wall of the screen room. The LISN was positioned on the floor of the screen room 80-cm from the rear of the EUT. Testing for the line-conducted emissions were the procedures of ANSI C63.10-2013 paragraph 6. The AC adapter for the EUT was connected to the LISN for line-conducted emissions testing. A second LISN was positioned on the floor of the screen room 80-cm from the rear of the supporting equipment of the EUT. All power cords except the EUT were then powered from the second LISN. EMI was coupled to the spectrum analyzer through a 0.1 μ F capacitor, internal to the LISN. Power line conducted emissions testing was carried out individually for each current carrying conductor of the EUT. The excess length of lead between the system and the LISN receptacle was folded back and forth to form a bundle not exceeding 40 cm in length. The screen room, conducting ground plane, analyzer, and LISN were bonded together to the protective earth ground. Preliminary testing was performed to identify the frequencies of each of the emissions, which demonstrated the highest amplitudes. The cables were repositioned to obtain maximum amplitude of measured EMI level. Once the worst-case configuration was identified, plots were made of the EMI from 0.15 MHz to 30 MHz then data was recorded with maximum conducted emissions levels.

Refer to figures one through two showing plots of the computer configuration line conducted emissions and figures three through six for plots of the AC adapter AC Line conducted emissions.

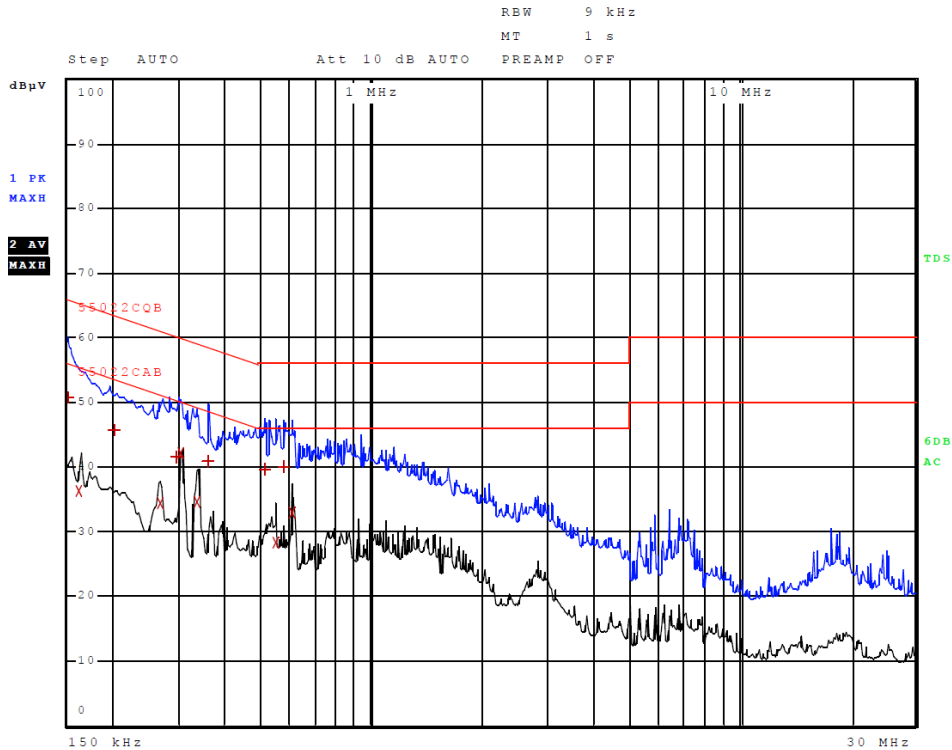

Figure 1 AC Line Conducted emissions of EUT line 1 (#2, EUT – Computer)

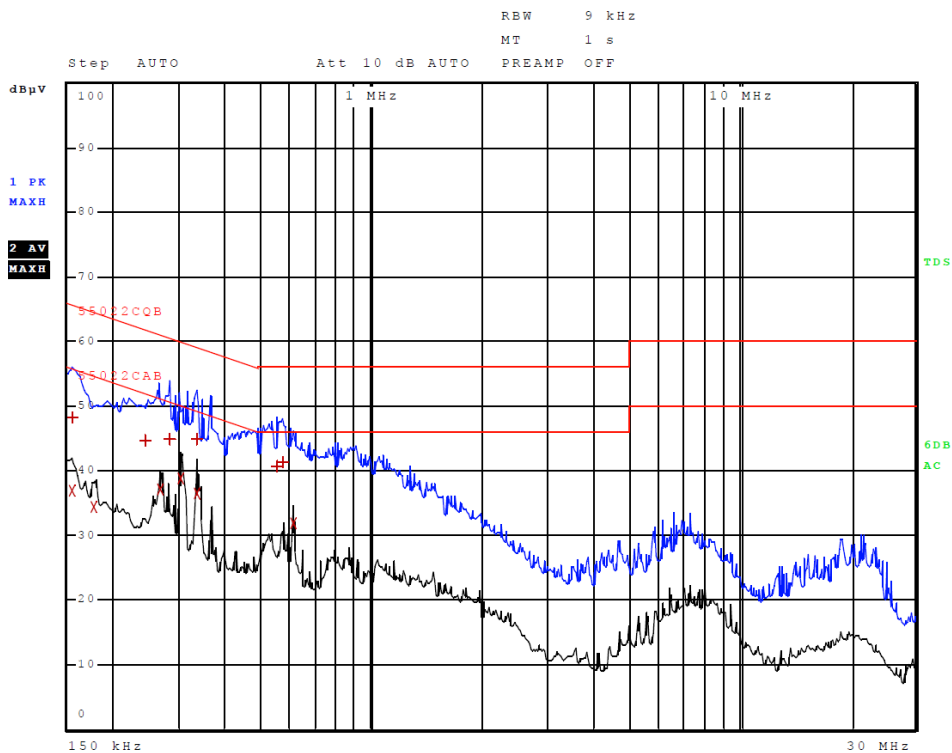

Figure 2 AC Line Conducted emissions of EUT line 2 (#2, EUT – Computer)

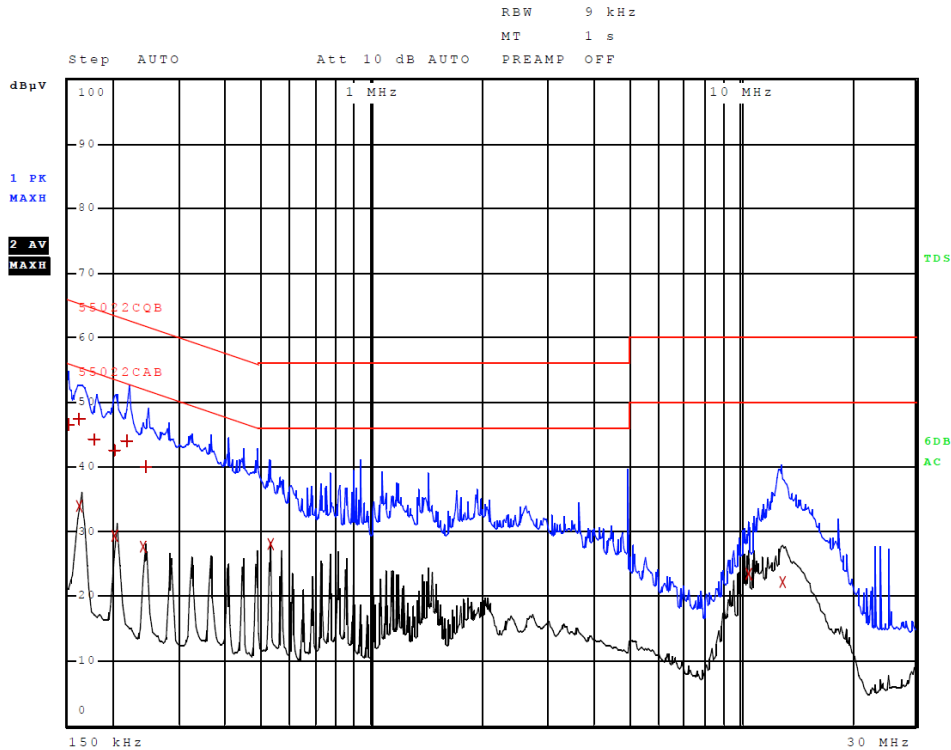

Figure 3 AC Line Conducted emissions of EUT line 1 (#4, EUT – AC Adapter)

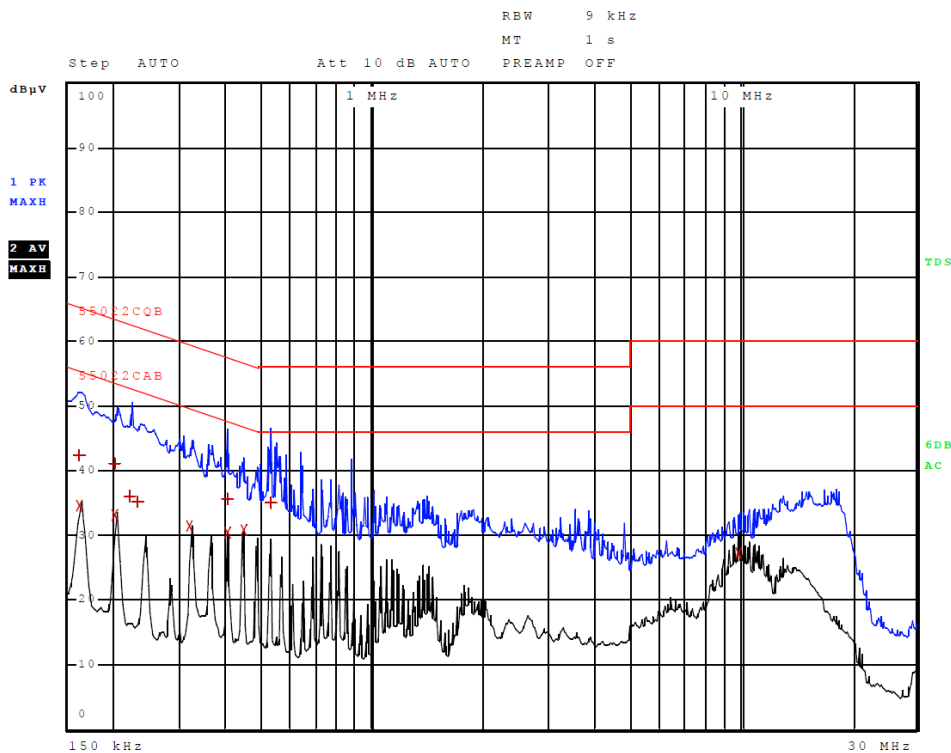

Figure 4 AC Line Conducted emissions of EUT line 2 (#4, EUT – AC Adapter)

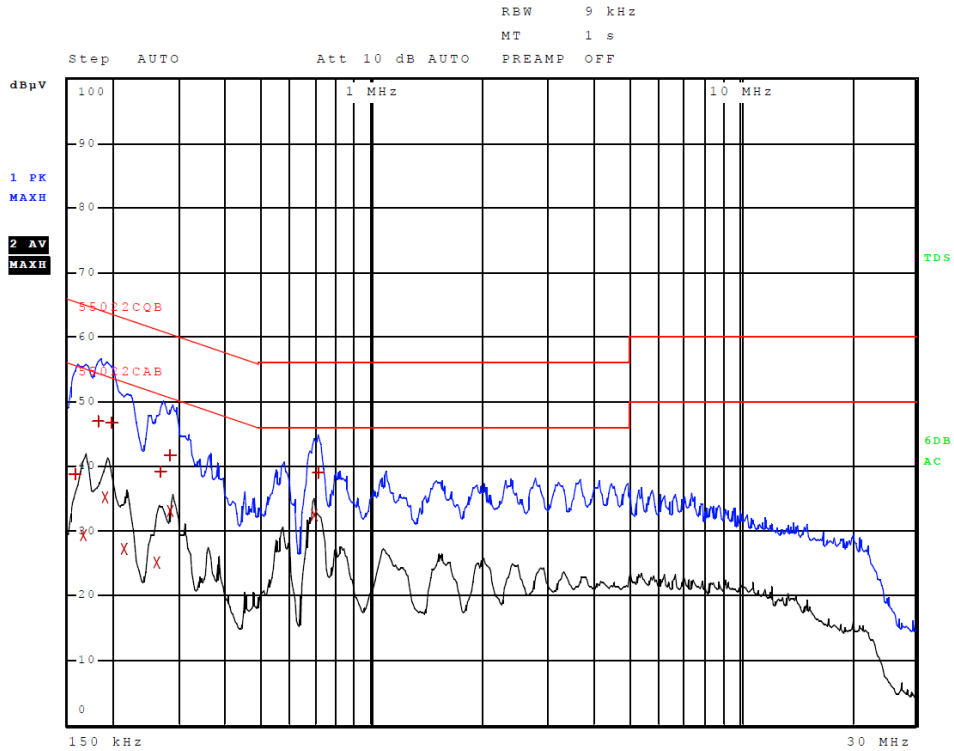

Figure 5 AC Line Conducted emissions of EUT line 1 (#5, EUT – AC Adapter)

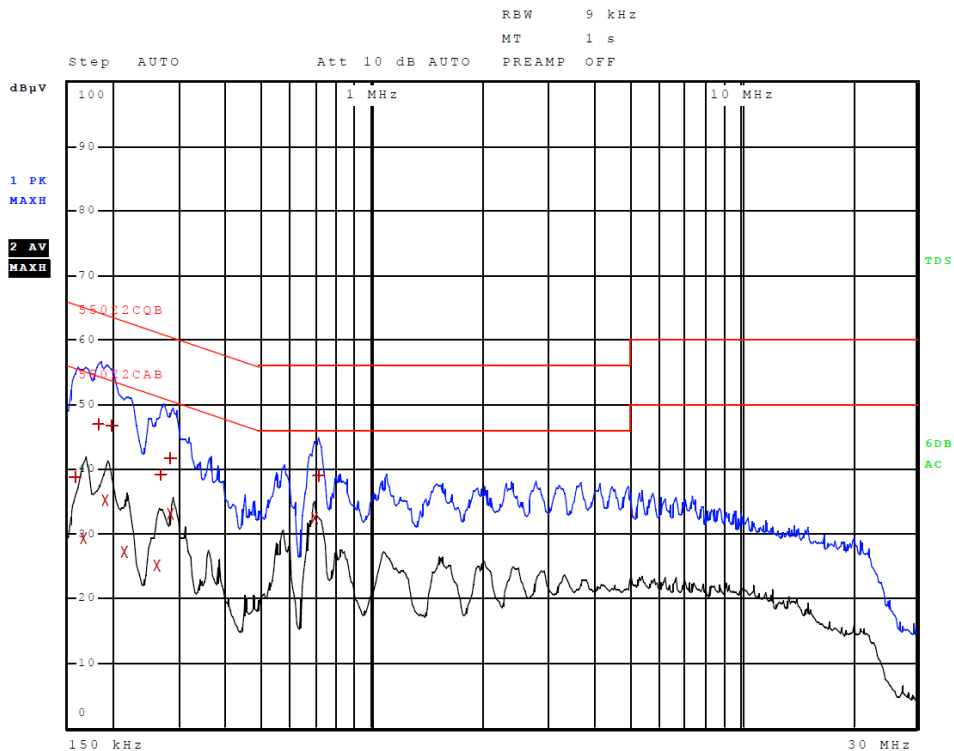

Figure 6 AC Line Conducted emissions of EUT line 2 (#5, EUT – AC Adapter)

Table 3 AC Line Conducted Emissions Data L1 (#2, EUT – Computer)

| Trace | Frequency | Level (dBµV) | Detector | Delta Limit/dB |
|-------|-------------------|--------------|------------|----------------|
| 1 | 150.000000000 kHz | 50.67 | Quasi Peak | -15.33 |
| 2 | 162.000000000 kHz | 36.30 | Average | -19.06 |
| 1 | 202.000000000 kHz | 45.65 | Quasi Peak | -17.88 |
| 2 | 266.000000000 kHz | 34.26 | Average | -16.98 |
| 1 | 298.000000000 kHz | 41.60 | Quasi Peak | -18.70 |
| 2 | 306.000000000 kHz | 42.07 | Average | -8.00 |
| 2 | 338.000000000 kHz | 34.51 | Average | -14.74 |
| 1 | 358.000000000 kHz | 40.82 | Quasi Peak | -17.96 |
| 1 | 510.000000000 kHz | 39.56 | Quasi Peak | -16.44 |
| 2 | 546.000000000 kHz | 28.18 | Average | -17.82 |
| 1 | 574.000000000 kHz | 39.92 | Quasi Peak | -16.08 |
| 2 | 606.000000000 kHz | 32.77 | Average | -13.23 |

Other emissions present had amplitudes at least 20 dB below the limit.

Table 4 AC Line Conducted Emissions Data L2 (#2, EUT – Computer)

| Trace | Frequency | Level (dBµV) | Detector | Delta Limit/dB |
|-------|-------------------|--------------|------------|----------------|
| 1 | 154.000000000 kHz | 48.24 | Quasi Peak | -17.55 |
| 2 | 154.000000000 kHz | 36.84 | Average | -18.94 |
| 2 | 178.000000000 kHz | 34.41 | Average | -20.17 |
| 1 | 246.000000000 kHz | 44.64 | Quasi Peak | -17.26 |
| 2 | 266.000000000 kHz | 37.18 | Average | -14.06 |
| 1 | 282.000000000 kHz | 44.82 | Quasi Peak | -15.94 |
| 2 | 302.000000000 kHz | 38.81 | Average | -11.38 |
| 2 | 334.000000000 kHz | 36.47 | Average | -12.88 |
| 1 | 334.000000000 kHz | 44.86 | Quasi Peak | -14.49 |
| 1 | 550.000000000 kHz | 40.75 | Quasi Peak | -15.25 |
| 1 | 570.000000000 kHz | 41.19 | Quasi Peak | -14.81 |
| 2 | 610.000000000 kHz | 31.92 | Average | -14.08 |

Other emissions present had amplitudes at least 20 dB below the limit.

Table 5 AC Line Conducted Emissions Data L1 (#3, EUT – 362-00072-00)

| Trace | Frequency | Level (dBµV) | Detector | Delta Limit/dB |
|-------|-------------------|--------------|------------|----------------|
| 1 | 150.000000000 kHz | 46.45 | Quasi Peak | -19.55 |
| 2 | 162.000000000 kHz | 33.92 | Average | -21.44 |
| 1 | 162.000000000 kHz | 47.30 | Quasi Peak | -18.06 |
| 1 | 178.000000000 kHz | 44.31 | Quasi Peak | -20.27 |
| 2 | 202.000000000 kHz | 29.39 | Average | -24.14 |
| 1 | 202.000000000 kHz | 42.52 | Quasi Peak | -21.01 |
| 1 | 218.000000000 kHz | 44.07 | Quasi Peak | -18.83 |
| 2 | 242.000000000 kHz | 27.52 | Average | -24.50 |
| 1 | 246.000000000 kHz | 40.12 | Quasi Peak | -21.77 |
| 2 | 526.000000000 kHz | 28.09 | Average | -17.91 |
| 2 | 10.588000000 MHz | 23.51 | Average | -26.49 |
| 2 | 13.032000000 MHz | 22.22 | Average | -27.78 |

Other emissions present had amplitudes at least 20 dB below the limit.

Table 6 AC Line Conducted Emissions Data L2 (#3, EUT – 362-00072-00)

| Trace | Frequency | Level (dBµV) | Detector | Delta Limit/dB |
|-------|-------------------|--------------|------------|----------------|
| 2 | 162.000000000 kHz | 34.60 | Average | -20.76 |
| 1 | 162.000000000 kHz | 42.37 | Quasi Peak | -22.99 |
| 2 | 202.000000000 kHz | 33.02 | Average | -20.51 |
| 1 | 202.000000000 kHz | 41.06 | Quasi Peak | -22.47 |
| 1 | 222.000000000 kHz | 35.92 | Quasi Peak | -26.82 |
| 1 | 234.000000000 kHz | 35.29 | Quasi Peak | -27.02 |
| 2 | 322.000000000 kHz | 31.42 | Average | -18.23 |
| 2 | 402.000000000 kHz | 30.29 | Average | -17.52 |
| 1 | 402.000000000 kHz | 35.58 | Quasi Peak | -22.23 |
| 2 | 446.000000000 kHz | 30.83 | Average | -16.12 |
| 1 | 526.000000000 kHz | 35.07 | Quasi Peak | -20.93 |
| 2 | 9.892000000 MHz | 27.28 | Average | -22.72 |

Other emissions present had amplitudes at least 20 dB below the limit.

Table 7 AC Line Conducted Emissions Data L1 (#4, EUT – 362-00087-00)

| Trace | Frequency | Level (dBµV) | Detector | Delta Limit/dB |
|-------|-------------------|--------------|------------|----------------|
| 1 | 158.000000000 kHz | 38.79 | Quasi Peak | -26.78 |
| 2 | 166.000000000 kHz | 29.24 | Average | -25.92 |
| 1 | 182.000000000 kHz | 47.02 | Quasi Peak | -17.37 |
| 2 | 190.000000000 kHz | 35.26 | Average | -18.77 |
| 1 | 198.000000000 kHz | 46.74 | Quasi Peak | -16.95 |
| 2 | 214.000000000 kHz | 27.29 | Average | -25.75 |
| 2 | 262.000000000 kHz | 25.12 | Average | -26.24 |
| 1 | 270.000000000 kHz | 39.17 | Quasi Peak | -21.95 |
| 2 | 286.000000000 kHz | 33.06 | Average | -17.58 |
| 1 | 286.000000000 kHz | 41.78 | Quasi Peak | -18.86 |
| 2 | 694.000000000 kHz | 32.42 | Average | -13.58 |
| 1 | 710.000000000 kHz | 39.06 | Quasi Peak | -16.94 |

Other emissions present had amplitudes at least 20 dB below the limit.

Table 8 AC Line Conducted Emissions Data L2 (#3, EUT – 362-00087-00)

| Trace | Frequency | Level (dBµV) | Detector | Delta Limit/dB |
|-------|-------------------|--------------|------------|----------------|
| 1 | 178.000000000 kHz | 43.02 | Quasi Peak | -21.56 |
| 2 | 194.000000000 kHz | 29.34 | Average | -24.53 |
| 1 | 274.000000000 kHz | 35.75 | Quasi Peak | -25.24 |
| 2 | 286.000000000 kHz | 25.01 | Average | -25.63 |
| 1 | 286.000000000 kHz | 36.79 | Quasi Peak | -23.85 |
| 2 | 574.000000000 kHz | 22.56 | Average | -23.44 |
| 1 | 578.000000000 kHz | 33.07 | Quasi Peak | -22.93 |
| 2 | 686.000000000 kHz | 27.00 | Average | -19.00 |
| 1 | 710.000000000 kHz | 37.41 | Quasi Peak | -18.59 |
| 2 | 786.000000000 kHz | 21.83 | Average | -24.17 |
| 1 | 806.000000000 kHz | 34.07 | Quasi Peak | -21.93 |
| 2 | 1.082000000 MHz | 19.54 | Average | -26.46 |

Other emissions present had amplitudes at least 20 dB below the limit.

Summary of Results for AC Line Conducted Emissions Results

The EUT demonstrated compliance with the AC Line Conducted Emissions requirements of 47CFR Part 15B and other applicable emissions requirements. The worst-case EUT CPU configuration demonstrated a minimum margin of -19.5 dB below the FCC/IC requirements. The worst-case EUT AC adapter configuration #3 demonstrated a minimum margin of -12.0 dB below the FCC/IC requirements. The worst-case EUT AC adapter configuration #4 demonstrated a minimum margin of -13.0 dB below the FCC/IC requirements. Other emissions were present with amplitudes at least 20 dB below the limit and worst-case amplitudes recorded.

General Radiated Emissions Procedure

The EUT was arranged in a typical equipment configuration and operated through all available mode during testing. Preliminary testing was performed in a screen room with the EUT positioned 1 meter from the FSM. Radiated emissions measurements were performed to identify the frequencies, which produced the highest emissions. Each radiated emission was then maximized at the OATS location before final radiated measurements were performed. Final data was taken with the EUT located at the OATS at a distance of 3 meters between the EUT and the receiving antenna. The frequency spectrum from 9 kHz to 25,000 MHz was searched for general radiated emissions. Measured emission levels were maximized by EUT placement on the table, rotating the turntable through 360 degrees, varying the antenna height between 1 and 4 meters above the ground plane and changing antenna position between horizontal and vertical polarization. Antennas used were Loop from 9 kHz to 30 MHz, Broadband Biconical from 30 to 200 MHz, Biconilog from 30 to 1000 MHz, Log Periodic from 200 MHz to 1 GHz and or double Ridge or pyramidal horns and mixers above 1 GHz, notch filters and appropriate amplifiers and external mixers were utilized.

Table 9 General Radiated Emissions Data

| Frequency in MHz | Horizontal Peak (dBµV/m) | Horizontal Quasi-Peak (dBµV/m) | Horizontal Average (dBµV/m) | Vertical Peak (dBµV/m) | Vertical Quasi-Peak (dBµV/m) | Vertical Average (dBµV/m) | Limit @ 3m (dBµV/m) |
|------------------|--------------------------|--------------------------------|-----------------------------|------------------------|------------------------------|---------------------------|---------------------|
| 2390.0 | 40.7 | N/A | 28.0 | 46.1 | N/A | 28.2 | 54.0 |
| 2483.5 | 41.5 | N/A | 28.7 | 41.6 | N/A | 28.9 | 54.0 |

Other emissions present had amplitudes at least 20 dB below the limit. Peak and Quasi-Peak amplitude emissions are recorded for frequency range below 1000 MHz. Peak and Average amplitude emissions are recorded for frequency range above 1000 MHz.

Summary of Results for General Radiated Emissions

The EUT demonstrated compliance with the radiated emissions requirements of CFR47 Part 15C paragraph 15.209, RSS-210 and RSS-GEN Intentional Radiators. The EUT demonstrated a minimum margin of -25.1 dB below the requirements. Other emissions were present with amplitudes at least 20 dB below the Limits.

Operation in the Band 2400 – 2483.5 MHz

The transmitter output power; harmonic and general emissions were measured on an open area test site @ 3 meters. The EUT was placed on a turntable elevated as required above the ground plane and at a distance of 3 meters from the FSM antenna. Both the low power transmitter and Satellite transmitter module were active during testing. The peak and quasi-peak amplitude of frequencies below 1000 MHz were measured using a spectrum analyzer. The peak and average amplitude of frequencies above 1000 MHz were measured using a spectrum analyzer. The amplitude of each emission was then recorded from the analyzer display. Emissions radiated outside of the specified bands, except for harmonics, shall be attenuated by at least 50 dB below the level of the fundamental or to the general radiated emission limits, whichever is the lesser attenuation. Antenna port emission plots were taken of transmitter performance for reference in this and other documentation using test sample #2. The amplitude of each radiated emission was measured on the OATS at a distance of 3 meters from the FSM antenna testing was performed on sample representative of production with integral antenna (sample #1) with worse case data provided. The amplitude of each radiated emission was maximized by equipment orientation and placement on the turn table, raising and lowering the FSM (Field Strength Measuring) antenna, changing the FSM antenna polarization, and by rotating the turntable. A Loop antenna was used for measuring emissions from 0.009 to 30 MHz, Biconilog Antenna for 30 to 1000 MHz, Double-Ridge, and/or Pyramidal Horn Antennas from 1 GHz to 25 GHz. Emissions were measured in dBuV/m @ 3 meters.

Refer to figures seven through ten showing plots taken of the 2402-2480 MHz, ANT modulation. Refer to figures eleven through fourteen showing plots of the BT BR (GFSK) performance displaying compliance with the specifications. Refer to figures fifteen through eighteen showing plots of the BT 2EDR (8DPSK) performance displaying compliance with the specifications. Refer to figures nineteen through twenty-two showing plots of the BT 3EDR (Pi/4-DPSK) performance displaying compliance with the specifications

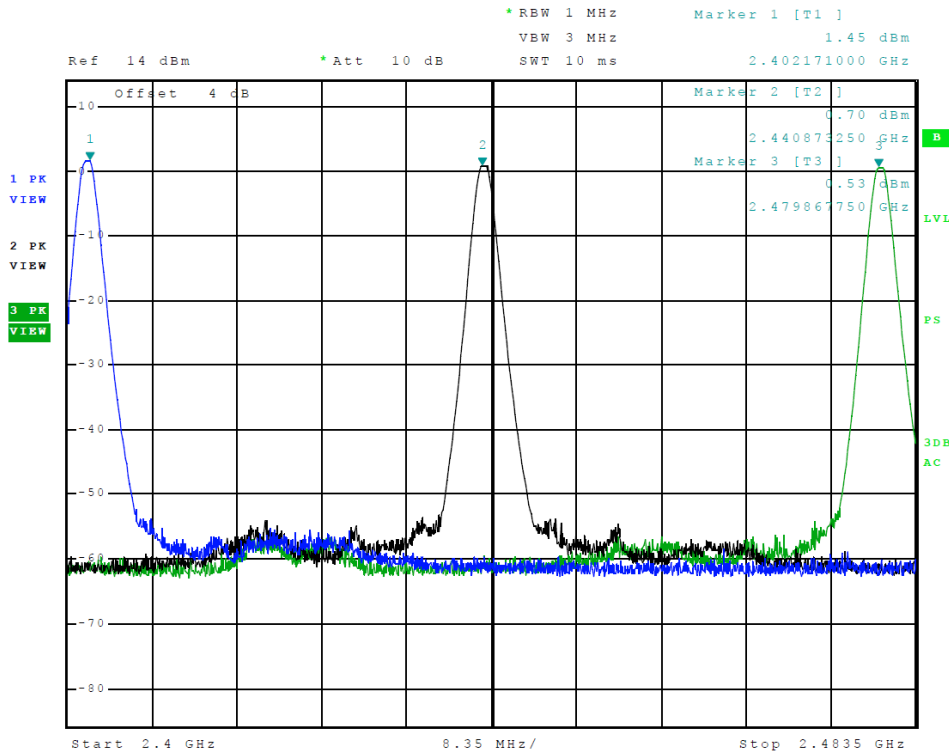

Figure 7 Plot of Transmitter Emissions (Operation in 2402-2480 MHz, ANT GFSK)

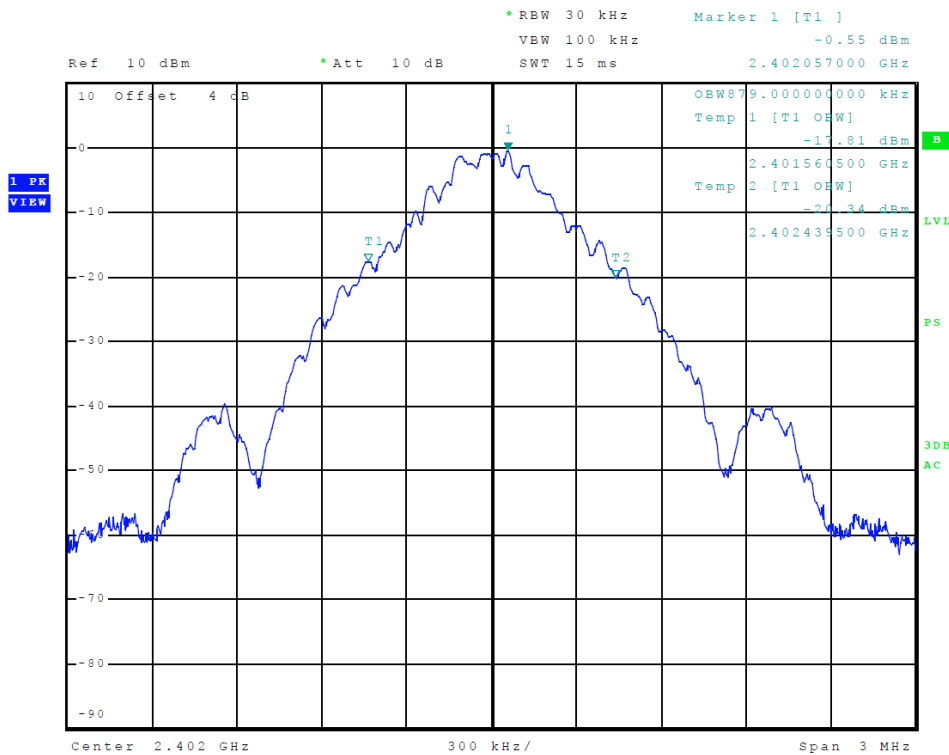

Figure 8 Plot of Transmitter Emissions (99% Occupied Bandwidth, ANT GFSK)

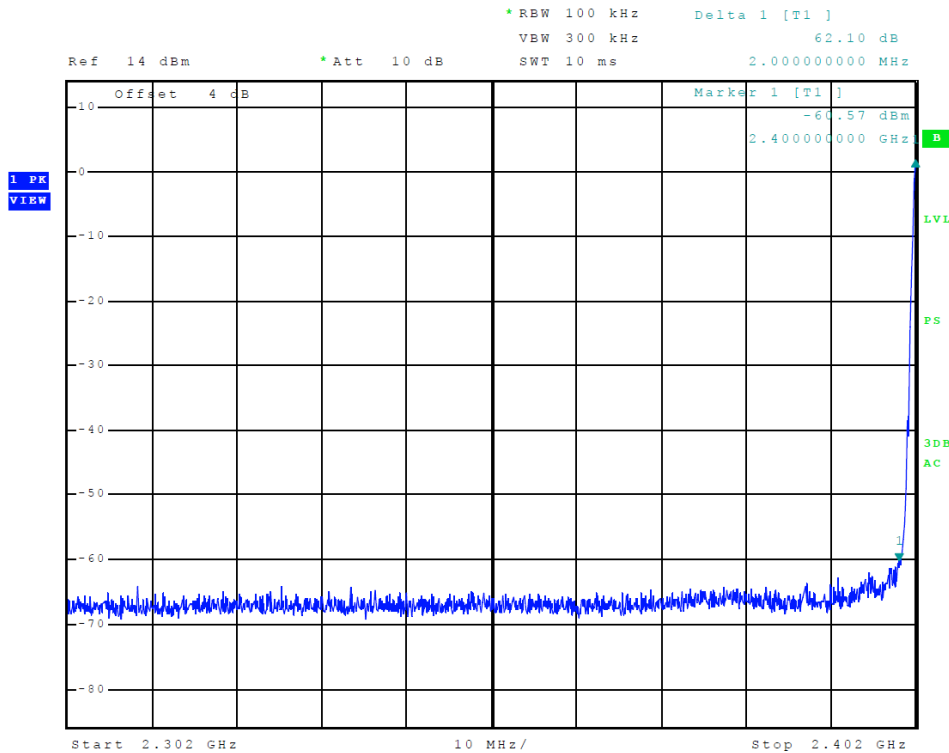

Figure 9 Plot of Transmitter Emissions (Low Band Edge, ANT GFSK)

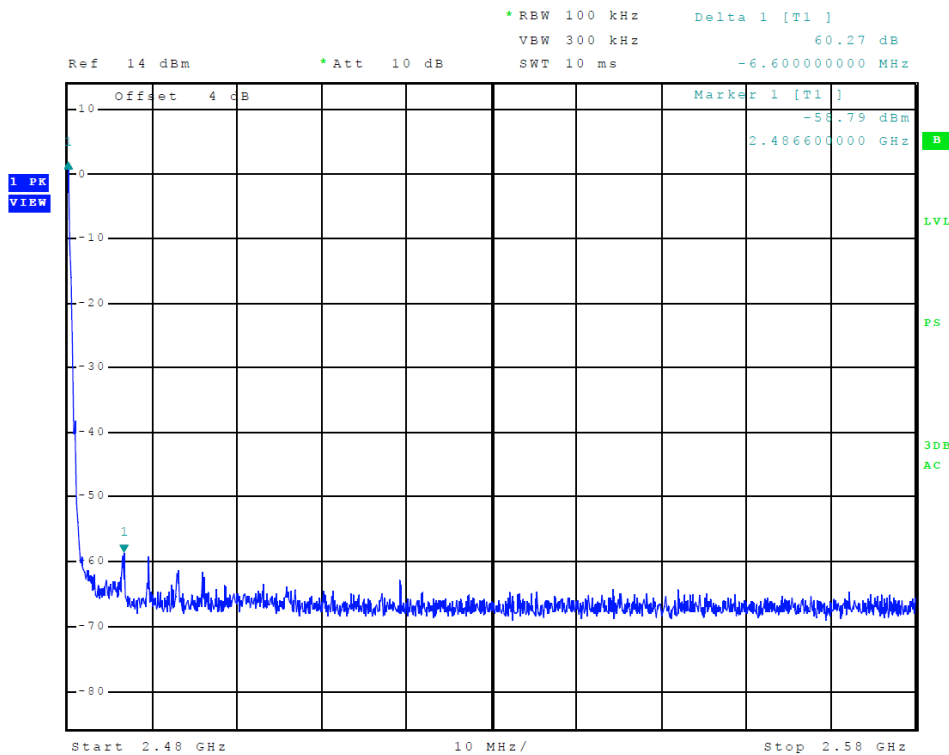

Figure 10 Plot of Transmitter Emissions (High Band Edge, ANT GFSK)

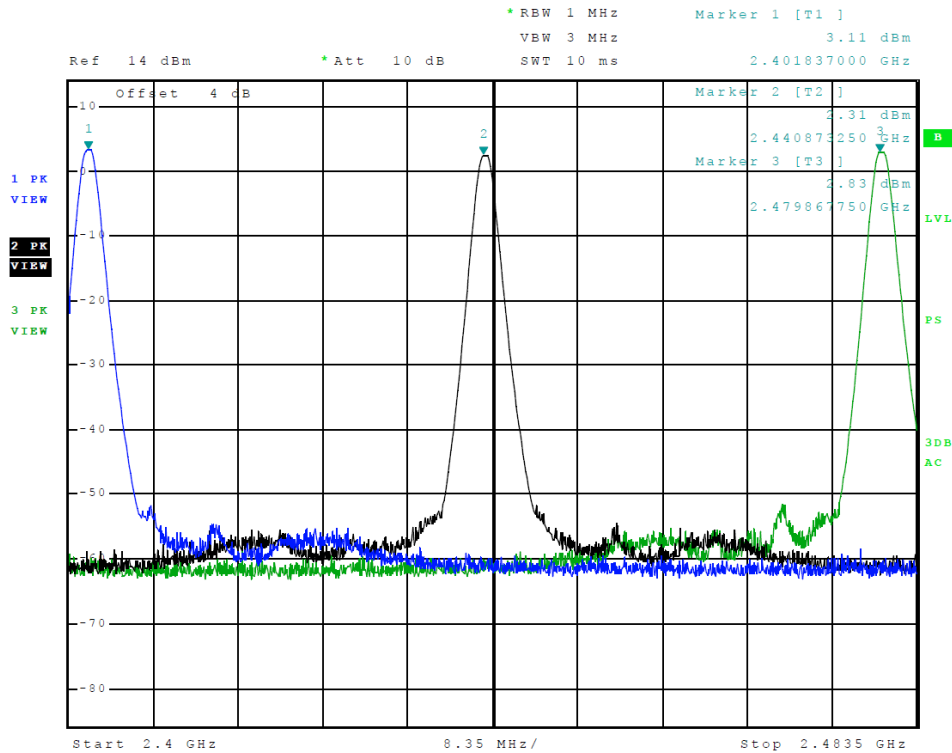

Figure 11 Plot of Transmitter Emissions (Operation in 2402-2480 MHz, BT GFSK)

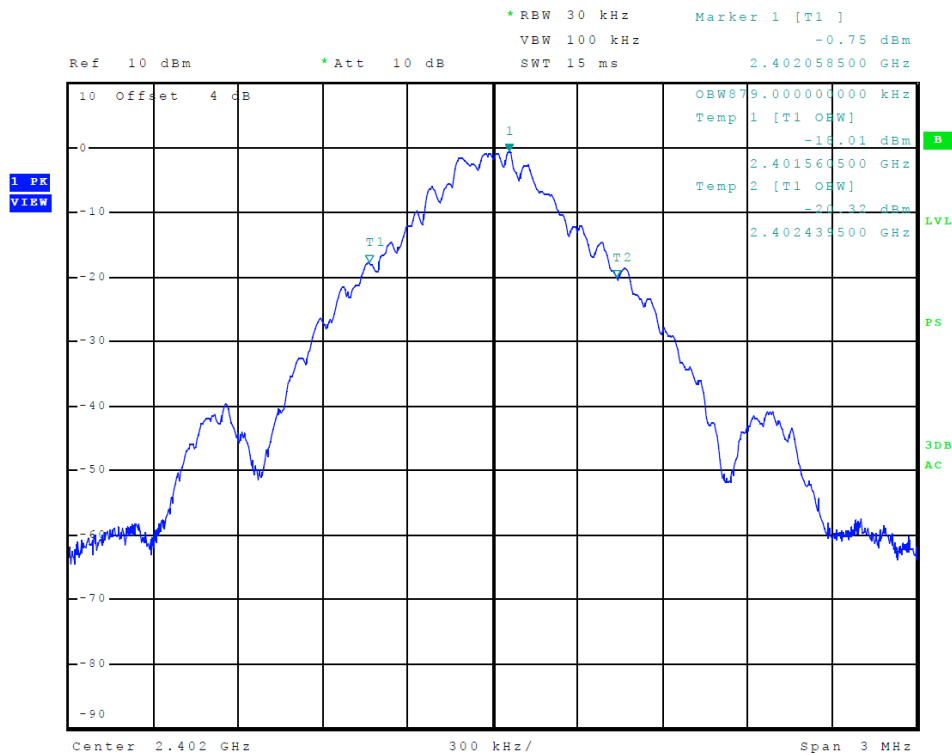

Figure 12 Plot of Transmitter Emissions (99% Occupied Bandwidth, BT GFSK)

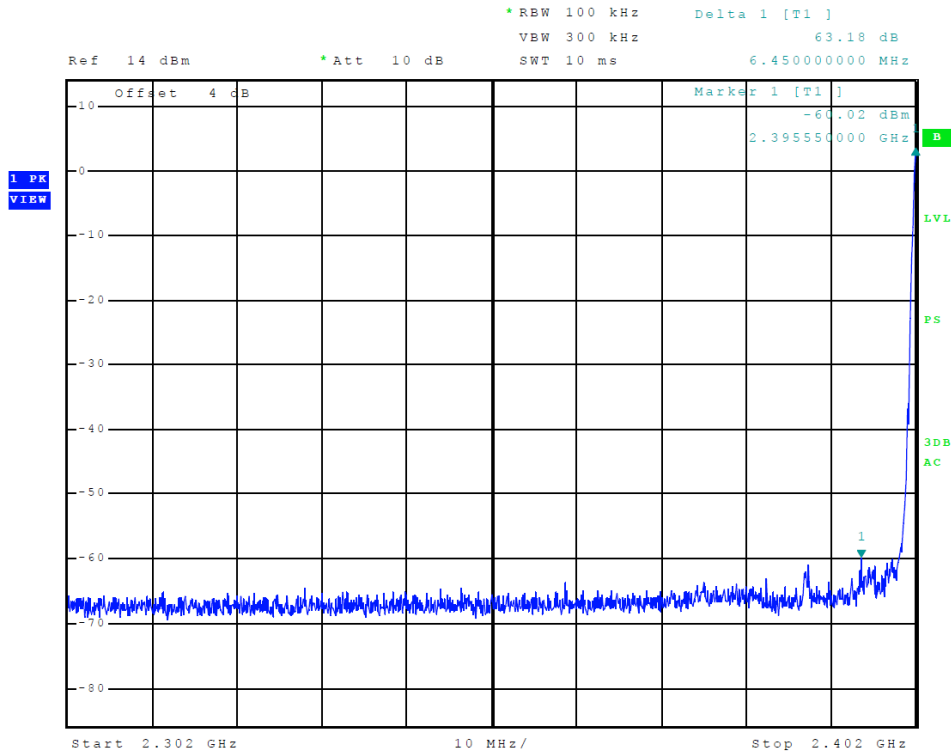

Figure 13 Plot of Transmitter Emissions (Low Band Edge, BT GFSK)

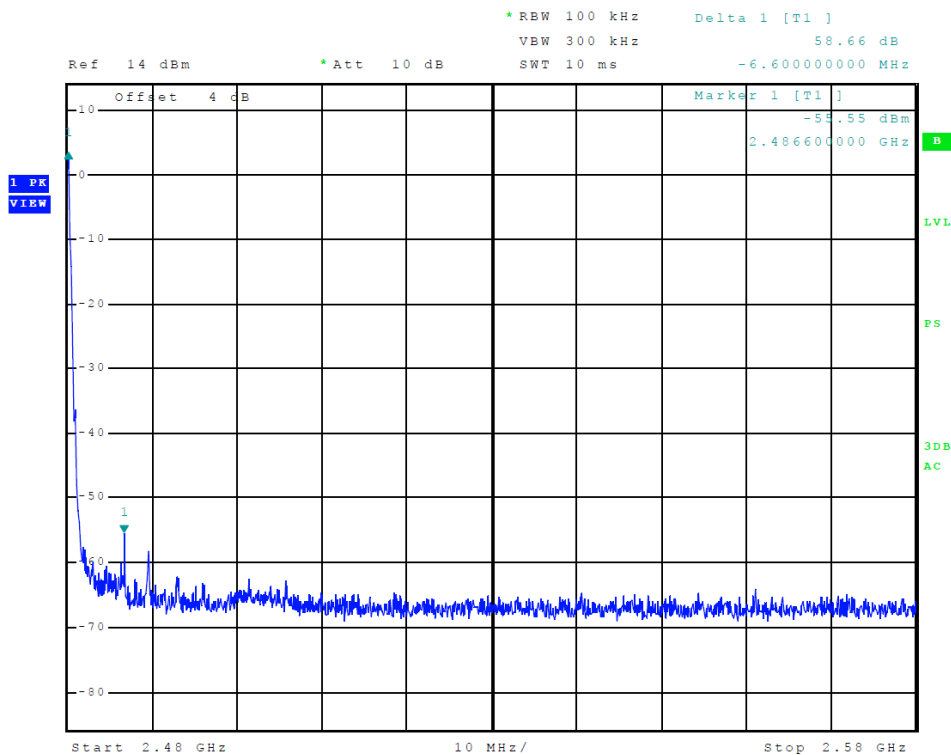

Figure 14 Plot of Transmitter Emissions (High Band Edge, BT GFSK)

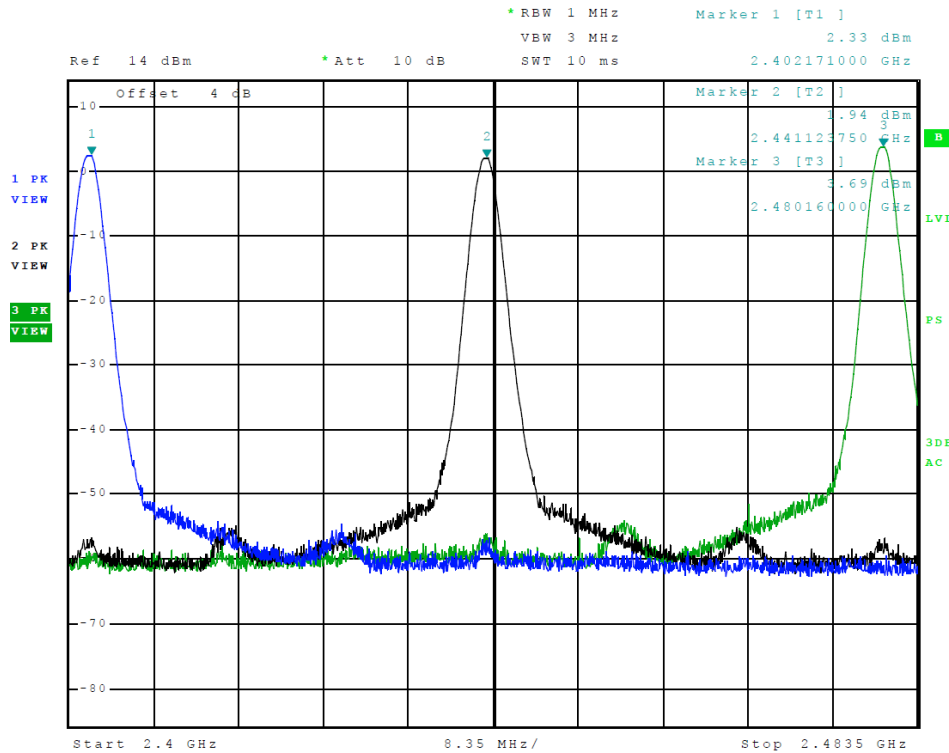

Figure 15 Plot of Transmitter Emissions (Operation in 2402-2480 MHz, BT 2EDR)

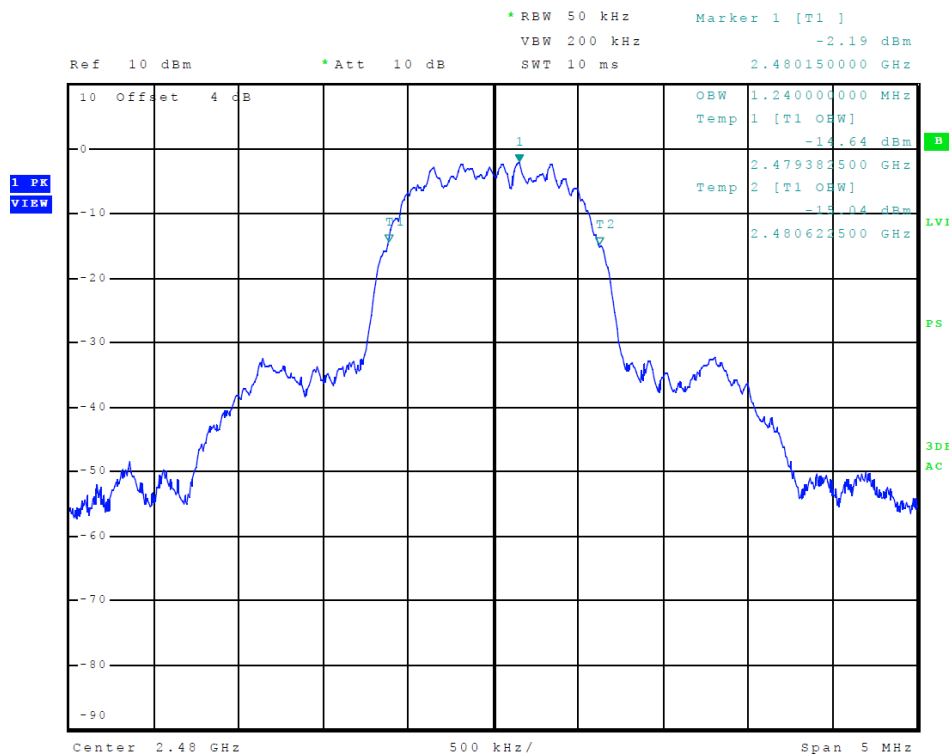

Figure 16 Plot of Transmitter Emissions (99% Occupied Bandwidth, BT 2EDR)

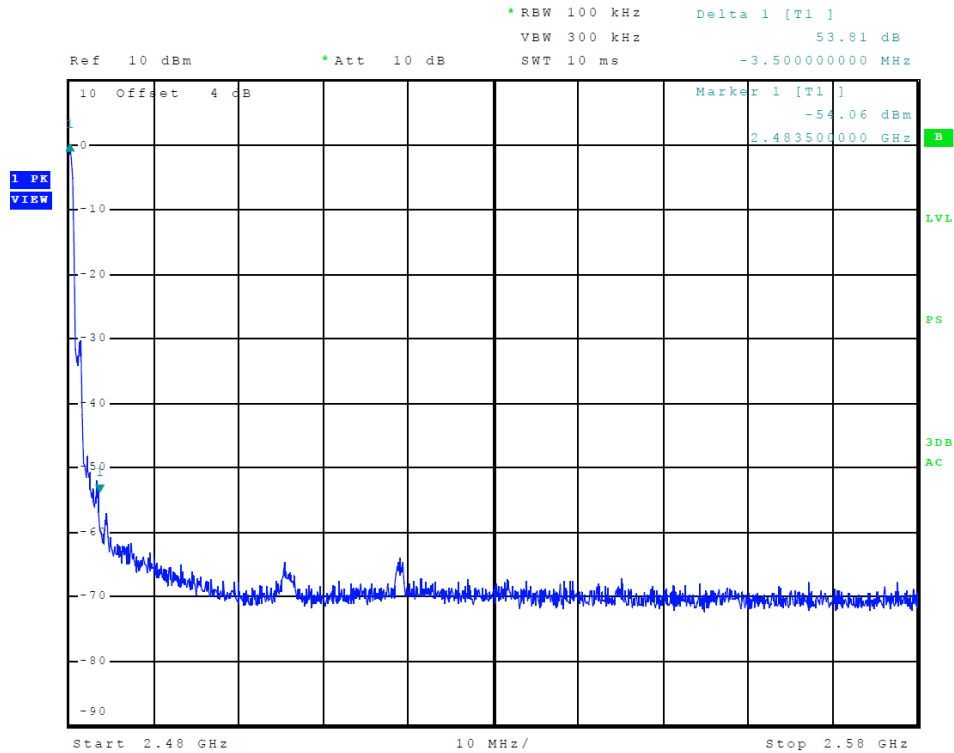

Figure 17 Plot of Transmitter Emissions (Low Band Edge, BT 2EDR)

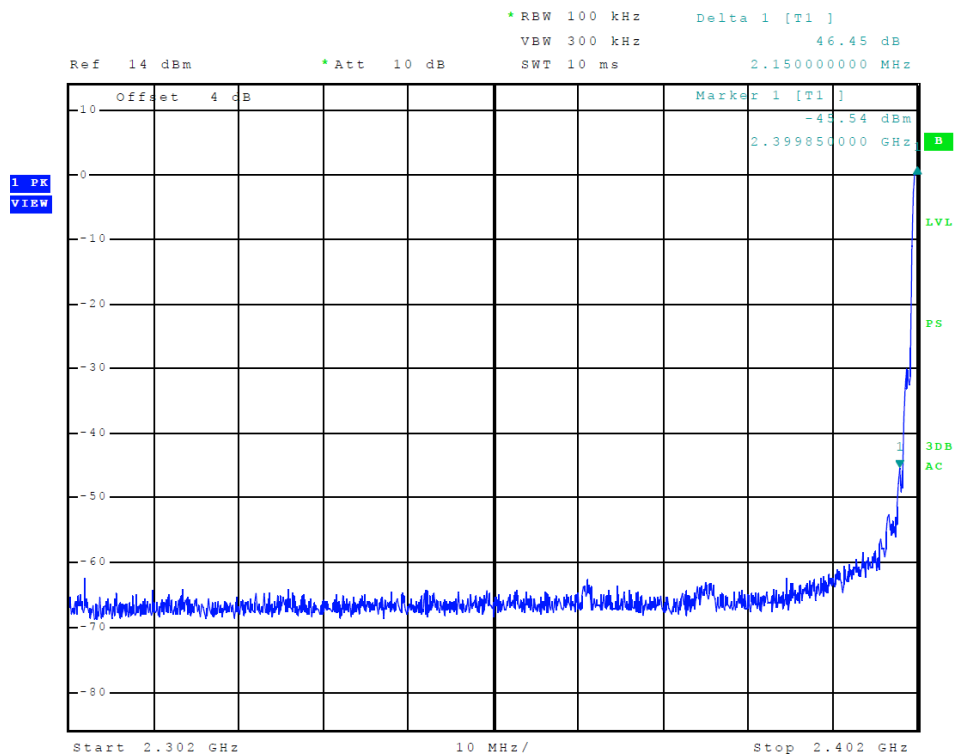

Figure 18 Plot of Transmitter Emissions (High Band Edge, BT 2EDR)

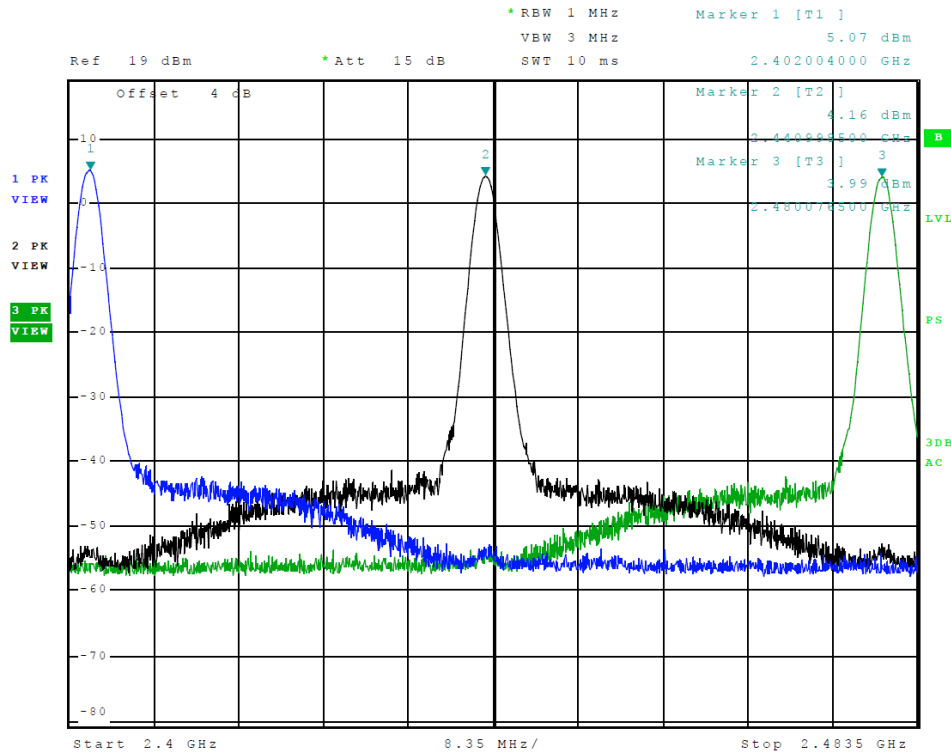

Figure 19 Plot of Transmitter Emissions (Operation in 2402-2480 MHz, BT 3EDR)

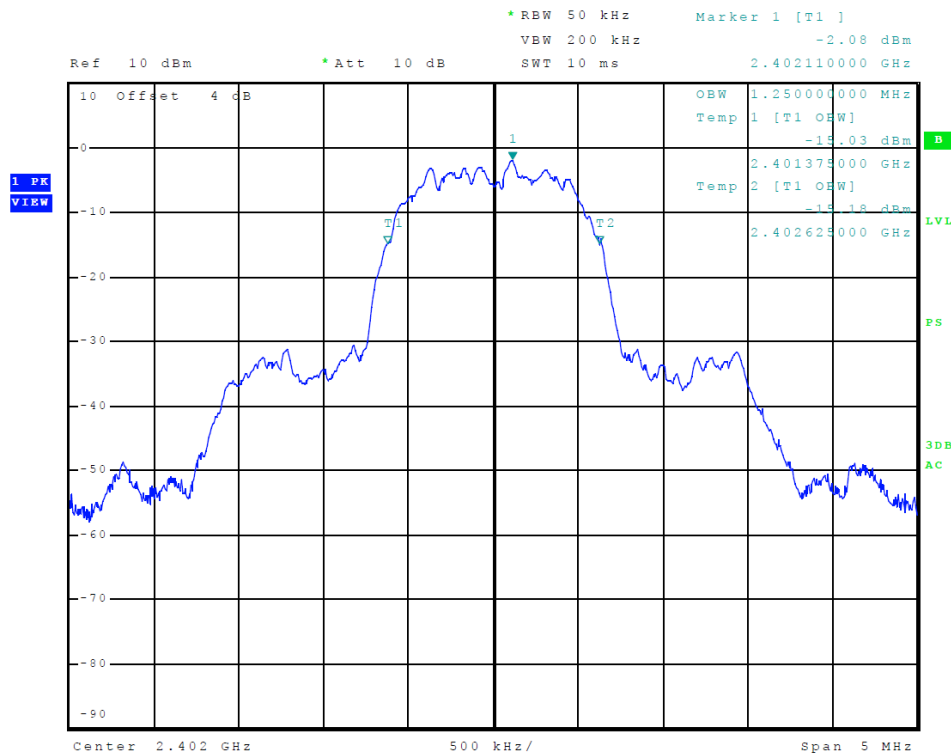

Figure 20 Plot of Transmitter Emissions (99% Occupied Bandwidth, B BT 3EDR)

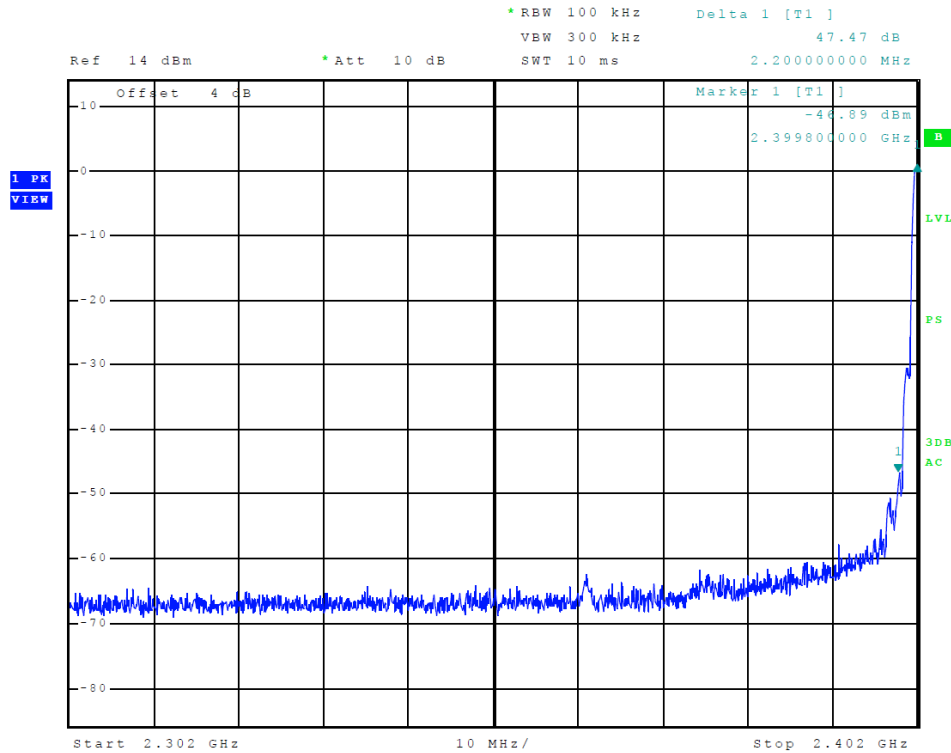

Figure 21 Plot of Transmitter Emissions (Low Band Edge, BT 3EDR)

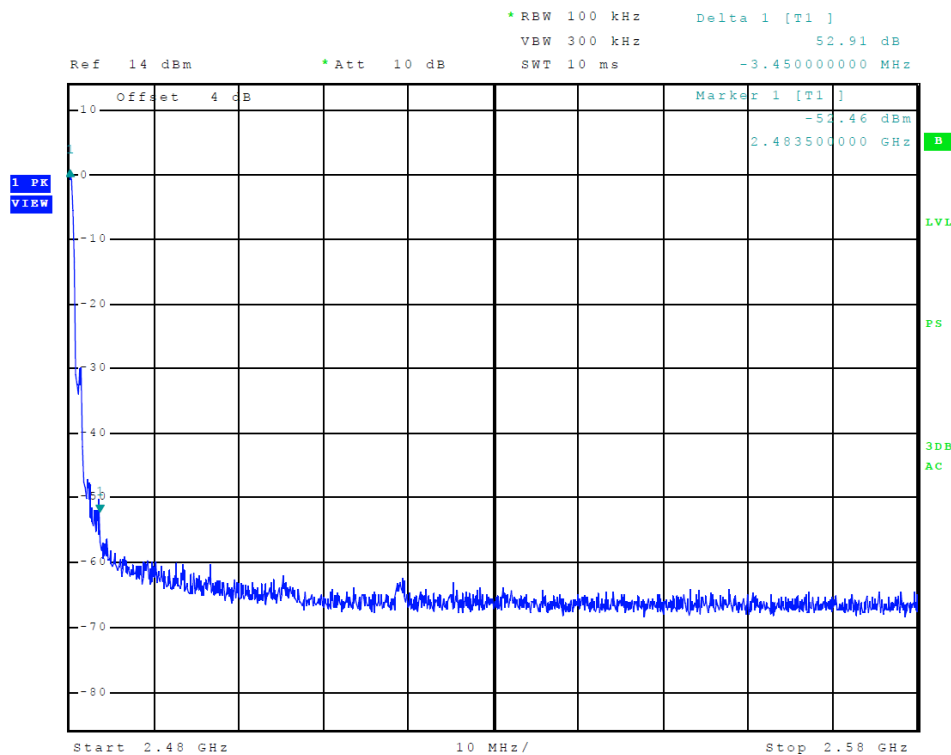

Figure 22 Plot of Transmitter Emissions (High Band Edge, BT 3EDR)

Transmitter Emissions Data

Table 10 Transmitter Radiated Emissions (Worst-case) ANT

| Frequency in MHz | Horizontal Peak (dB μ V/m) | Horizontal Quasi-Peak (dB μ V/m) | Horizontal Average (dB μ V/m) | Vertical Peak (dB μ V/m) | Vertical Quasi-Peak (dB μ V/m) | Vertical Average (dB μ V/m) | Limit @ 3m (dB μ V/m) |
|------------------|--------------------------------|--------------------------------------|-----------------------------------|------------------------------|------------------------------------|---------------------------------|---------------------------|
| 2402.0 | 88.4 | N/A | 87.5 | 93.0 | N/A | 92.1 | 94.0 |
| 4804.0 | 44.0 | N/A | 31.0 | 44.3 | N/A | 31.0 | 54.0 |
| 7206.0 | 44.4 | N/A | 33.3 | 45.7 | N/A | 33.0 | 54.0 |
| 9608.0 | 46.6 | N/A | 33.9 | 47.4 | N/A | 34.4 | 54.0 |
| 12010.0 | 47.9 | N/A | 36.0 | 48.3 | N/A | 35.5 | 54.0 |
| 14412.0 | 50.6 | N/A | 36.9 | 50.1 | N/A | 37.3 | 54.0 |
| 16814.0 | 53.1 | N/A | 39.1 | 52.3 | N/A | 39.5 | 54.0 |
| 2441.0 | 87.1 | N/A | 85.7 | 91.2 | N/A | 90.5 | 94.0 |
| 4882.0 | 44.3 | N/A | 31.1 | 43.8 | N/A | 31.0 | 54.0 |
| 7323.0 | 46.0 | N/A | 32.4 | 45.7 | N/A | 32.5 | 54.0 |
| 9764.0 | 43.7 | N/A | 30.8 | 43.5 | N/A | 30.4 | 54.0 |
| 12205.0 | 49.6 | N/A | 36.6 | 49.5 | N/A | 36.9 | 54.0 |
| 14646.0 | 50.4 | N/A | 37.7 | 50.6 | N/A | 37.8 | 54.0 |
| 17087.0 | 54.1 | N/A | 41.1 | 53.6 | N/A | 41.1 | 54.0 |
| 2480.0 | 83.5 | N/A | 83.0 | 87.7 | N/A | 87.3 | 94.0 |
| 4960.0 | 44.9 | N/A | 33.0 | 44.2 | N/A | 31.2 | 54.0 |
| 7440.0 | 45.4 | N/A | 32.9 | 46.1 | N/A | 33.0 | 54.0 |
| 9920.0 | 43.5 | N/A | 30.7 | 46.7 | N/A | 33.5 | 54.0 |
| 12400.0 | 50.1 | N/A | 36.8 | 50.2 | N/A | 37.1 | 54.0 |
| 14880.0 | 49.0 | N/A | 35.8 | 49.1 | N/A | 36.5 | 54.0 |
| 17360.0 | 53.9 | N/A | 41.0 | 50.9 | N/A | 38.2 | 54.0 |

Other emissions present had amplitudes at least 20 dB below the limit. Peak and Quasi-Peak amplitude emissions are recorded for frequency range below 1000 MHz. Peak and Average amplitude emissions are recorded for frequency range above 1000 MHz.

Table 11 Transmitter Radiated Emissions (Worst-case) BT

| Frequency in MHz | Horizontal Peak (dB μ V/m) | Horizontal Quasi-Peak (dB μ V/m) | Horizontal Average (dB μ V/m) | Vertical Peak (dB μ V/m) | Vertical Quasi-Peak (dB μ V/m) | Vertical Average (dB μ V/m) | Limit @ 3m (dB μ V/m) |
|------------------|--------------------------------|--------------------------------------|-----------------------------------|------------------------------|------------------------------------|---------------------------------|---------------------------|
| 2402.0 | 84.0 | N/A | 87.5 | 92.9 | N/A | 92.1 | 94.0 |
| 4804.0 | 43.7 | N/A | 31.0 | 44.3 | N/A | 31.0 | 54.0 |
| 7206.0 | 46.4 | N/A | 33.3 | 45.7 | N/A | 33.0 | 54.0 |
| 9608.0 | 47.9 | N/A | 33.9 | 47.4 | N/A | 34.4 | 54.0 |
| 12010.0 | 49.0 | N/A | 36.0 | 48.3 | N/A | 35.5 | 54.0 |
| 14412.0 | 49.8 | N/A | 36.9 | 50.1 | N/A | 37.2 | 54.0 |
| 16814.0 | 51.9 | N/A | 39.1 | 52.3 | N/A | 39.5 | 54.0 |
| 2440.0 | 87.3 | N/A | 86.2 | 91.5 | N/A | 90.5 | 94.0 |
| 4880.0 | 43.8 | N/A | 30.9 | 43.5 | N/A | 30.6 | 54.0 |
| 7320.0 | 44.4 | N/A | 31.9 | 45.1 | N/A | 32.2 | 54.0 |
| 9760.0 | 46.2 | N/A | 33.5 | 47.7 | N/A | 34.4 | 54.0 |
| 12200.0 | 49.6 | N/A | 36.8 | 50.1 | N/A | 37.1 | 54.0 |
| 14640.0 | 50.2 | N/A | 37.7 | 51.1 | N/A | 38.0 | 54.0 |
| 17080.0 | 54.6 | N/A | 41.2 | 53.6 | N/A | 40.8 | 54.0 |
| 2480.0 | 83.0 | N/A | 82.6 | 87.3 | N/A | 87.0 | 94.0 |
| 4960.0 | 44.5 | N/A | 31.5 | 44.5 | N/A | 31.4 | 54.0 |
| 7440.0 | 45.7 | N/A | 32.1 | 45.9 | N/A | 32.8 | 54.0 |
| 9920.0 | 46.6 | N/A | 33.8 | 43.4 | N/A | 30.6 | 54.0 |
| 12400.0 | 50.1 | N/A | 36.6 | 49.9 | N/A | 36.8 | 54.0 |
| 14880.0 | 48.4 | N/A | 35.8 | 49.5 | N/A | 36.3 | 54.0 |
| 17360.0 | 53.5 | N/A | 40.8 | 52.3 | N/A | 39.4 | 54.0 |

Other emissions present had amplitudes at least 20 dB below the limit. Peak and Quasi-Peak amplitude emissions are recorded for frequency range below 1000 MHz. Peak and Average amplitude emissions are recorded for frequency range above 1000 MHz.

Summary of Results for Transmitter Radiated Emissions of Intentional Radiator

The EUT demonstrated compliance with the radiated emissions requirements of FCC 47 CFR Part 15.249, Industry Canada RSS-GEN issue 4, RSS-210 issue 9 Intentional Radiator regulations. The EUT ANT modulation worst-case test sample configuration demonstrated minimum average margin of -1.9 dB below the average emission limit for the fundamental. The EUT Worst-case BT modulation configuration demonstrated minimum average margin of -1.9 dB below the average emission limit for the fundamental. The EUT worst-case configuration demonstrated minimum radiated harmonic emission margin of -12.8 dB below the limit. No other radiated emissions were found in the restricted bands less than 20 dB below limits than those recorded in this report. Other emissions were present with amplitudes at least 20 dB below the limits.

Annex

- Annex A Measurement Uncertainty Calculations
- Annex B Rogers Labs Test Equipment List
- Annex C Rogers Qualifications
- Annex D Rogers Labs Certificate of Accreditation

Annex A Measurement Uncertainty Calculations

Measurement uncertainty calculations were made for the laboratory. Result of measurement uncertainty calculations are recorded below for AC line conducted and radiated emission measurements.

| Measurement Uncertainty | U _(E) | U _(lab) |
|-----------------------------------------------|------------------|--------------------|
| 3 Meter Horizontal 30-200 MHz Measurements | 2.08 | 4.16 |
| 3 Meter Vertical 30-200 MHz Measurements | 2.16 | 4.33 |
| 3 Meter Vertical Measurements 200-1000 MHz | 2.99 | 5.97 |
| 10 Meter Horizontal Measurements 30-200 MHz | 2.07 | 4.15 |
| 10 Meter Vertical Measurements 30-200 MHz | 2.06 | 4.13 |
| 10 Meter Horizontal Measurements 200-1000 MHz | 2.32 | 4.64 |
| 10 Meter Vertical Measurements 200-1000 MHz | 2.33 | 4.66 |
| 3 Meter Measurements 1-6 GHz | 2.57 | 5.14 |
| 3 Meter Measurements 6-18 GHz | 2.58 | 5.16 |
| AC Line Conducted | 1.72 | 3.43 |

Annex B Rogers Labs Test Equipment List

| List of Test Equipment | Calibration | Date | Due |
|-------------------------------------------------------------------------|-------------|----------|----------|
| Spectrum Analyzer: Rohde & Schwarz ESU40 | | 30/5/17 | 30/5/18 |
| Spectrum Analyzer: HP 8562A, HP Adapters: 11518, 11519, and 11520 | | 30/5/17 | 30/5/18 |
| Mixers: 11517A, 11970A, 11970K, 11970U, 11970V, 11970W | | | |
| Spectrum Analyzer: HP 8591EM | | 30/5/17 | 30/5/18 |
| Antenna: EMCO Biconilog Model: 3143 | | 30/5/17 | 30/5/18 |
| Antenna: Sunol Biconilog Model: JB6 | | 24/10/17 | 24/10/18 |
| Antenna: EMCO Log Periodic Model: 3147 | | 24/10/17 | 24/10/18 |
| Antenna: Com Power Model: AH-118 | | 24/10/17 | 24/10/18 |
| Antenna: Com Power Model: AH-840 | | 30/5/17 | 30/5/18 |
| Antenna: Antenna Research Biconical Model: BCD 235 | | 24/10/17 | 24/10/18 |
| Antenna: Com Power Model: AL-130 | | 24/10/17 | 24/10/18 |
| Antenna: EMCO 6509 | | 24/10/17 | 24/10/18 |
| LISN: Compliance Design Model: FCC-LISN-2.Mod.cd, 50 µHy/50 ohms/0.1 µf | | 24/10/17 | 24/10/18 |
| R.F. Preamp CPPA-102 | | 24/10/17 | 24/10/18 |
| Attenuator: HP Model: HP11509A | | 24/10/17 | 24/10/18 |
| Attenuator: Mini Circuits Model: CAT-3 | | 24/10/17 | 24/10/18 |
| Attenuator: Mini Circuits Model: CAT-3 | | 24/10/17 | 24/10/18 |
| Cable: Belden RG-58 (L1) | | 24/10/17 | 24/10/18 |
| Cable: Belden RG-58 (L2) | | 24/10/17 | 24/10/18 |
| Cable: Belden 8268 (L3) | | 24/10/17 | 24/10/18 |
| Cable: Time Microwave: 4M-750HF290-750 | | 24/10/17 | 24/10/18 |
| Cable: Time Microwave: 10M-750HF290-750 | | 24/10/17 | 24/10/18 |
| Frequency Counter: Leader LDC825 | | 23/2/17 | 23/2/18 |
| Oscilloscope Scope: Tektronix 2230 | | 23/2/17 | 23/2/18 |
| Wattmeter: Bird 43 with Load Bird 8085 | | 23/2/17 | 23/2/18 |
| Power Supplies: Sorensen SRL 20-25, SRL 40-25, DCR 150, DCR 140 | | 23/2/17 | 23/2/18 |
| R.F. Generators: HP 606A, HP 8614A, HP 8640B | | 23/2/17 | 23/2/18 |
| R.F. Power Amp 65W Model: 470-A-1010 | | 23/2/17 | 23/2/18 |
| R.F. Power Amp 50W M185- 10-501 | | 23/2/17 | 23/2/18 |
| R.F. Power Amp A.R. Model: 10W 1010M7 | | 23/2/17 | 23/2/18 |
| R.F. Power Amp EIN Model: A301 | | 23/2/17 | 23/2/18 |
| LISN: Compliance Eng. Model 240/20 | | 23/2/17 | 23/2/18 |
| LISN: Fischer Custom Communications Model: FCC-LISN-50-16-2-08 | | 23/2/17 | 23/2/18 |
| Antenna: EMCO Dipole Set 3121C | | 23/2/17 | 23/2/18 |
| Antenna: C.D. B-101 | | 23/2/17 | 23/2/18 |
| Antenna: Solar 9229-1 & 9230-1 | | 23/2/17 | 23/2/18 |
| Audio Oscillator: H.P. 201CD | | 23/2/17 | 23/2/18 |
| ESD Test Set 2010i | | 23/2/17 | 23/2/18 |
| Fast Transient Burst Generator Model: EFT/B-101 | | 23/2/17 | 23/2/18 |
| Field Intensity Meter: EFM-018 | | 23/2/17 | 23/2/18 |
| KEYTEK Ecat Surge Generator | | 23/2/17 | 23/2/18 |
| Shielded Room 5 M x 3 M x 3.0 M, Not required | | | |

Annex C Rogers Qualifications

Scot D. Rogers, Engineer

Rogers Labs, Inc.

Mr. Rogers has approximately 17 years' experience in the field of electronics. Engineering experience includes six years in the automated controls industry and remaining years working with the design, development and testing of radio communications and electronic equipment.

Positions Held

Systems Engineer: A/C Controls Mfg. Co., Inc. 6 Years

Electrical Engineer: Rogers Consulting Labs, Inc. 5 Years

Electrical Engineer: Rogers Labs, Inc. Current

Educational Background

- 1) Bachelor of Science Degree in Electrical Engineering from Kansas State University.
- 2) Bachelor of Science Degree in Business Administration Kansas State University.
- 3) Several Specialized Training courses and seminars pertaining to Microprocessors and Software programming.

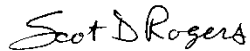

Scot D. Rogers

Annex D Rogers Labs Certificate of Accreditation

United States Department of Commerce
National Institute of Standards and Technology

NVLAP®

Certificate of Accreditation to ISO/IEC 17025:2005

NVLAP LAB CODE: 200087-0

Rogers Labs, Inc.
Louisburg, KS

*is accredited by the National Voluntary Laboratory Accreditation Program for specific services,
listed on the Scope of Accreditation, for:*

Electromagnetic Compatibility & Telecommunications

*This laboratory is accredited in accordance with the recognized International Standard ISO/IEC 17025:2005.
This accreditation demonstrates technical competence for a defined scope and the operation of a laboratory quality
management system (refer to joint ISO-ILAC-IAF Communiqué dated January 2009).*

2017-03-01 through 2018-03-31
Effective Dates



For the National Voluntary Laboratory Accreditation Program

Rogers Labs, Inc.
4405 West 259th Terrace
Louisburg, KS 66053
Phone/Fax: (913) 837-3214
Revision 3

Garmin International, Inc.
Model: A03322
Test #: 171204
Test to: CFR47 15C, RSS-Gen, RSS-210
File: A03322 DXX TstRpt 171204 r3

SN's: 5HT000004 / 5HT000001
FCC ID: IPH-03322
IC: 1792A-03322
Date: April 24, 2018
Page 44 of 44