

# Application For Grant of Certification

FOR

Models: A03198 and B03198  
2412-2462 MHz (DTS)  
Broadband Digital Transmission System  
FCC ID: IPH-03198  
IC: 1792A-03198

FOR

## Garmin International, Inc.

1200 East 151st Street  
Olathe, KS 66062

FCC Designation: US5305, Registration number: 315994

IC Test Site Registration: 3041A-1

Test Report Number: 170817

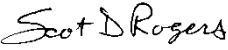
Authorized Signatory:   
Scot D. Rogers

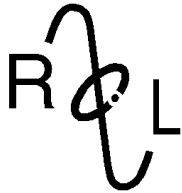

# **ROGERS LABS, INC.**

4405 West 259<sup>th</sup> Terrace  
Louisburg, KS 66053  
Phone / Fax (913) 837-3214

## Engineering Test Report For Grant of Certification Application

FOR  
CFR 47, PART 15C - Intentional Radiators  
CFR 47 Paragraph 15.247 and  
Industry Canada RSS-GEN and RSS-247  
License Exempt Intentional Radiator

For  
**Garmin International, Inc.**

1200 East 151st Street  
Olathe, KS 66062

Digital Transmission System  
Models: A03198 and B03198

Frequency Range 2412-2462 MHz  
FCC ID: IPH-03198  
IC: 1792A-03198

Test Date: August 17, 2017

Certifying Engineer: *Scot D. Rogers*  
Scot D. Rogers  
Rogers Labs, Inc.  
4405 West 259<sup>th</sup> Terrace  
Louisburg, KS 66053  
Telephone/Facsimile: (913) 837-3214

This report shall not be reproduced except in full, without the written approval of the laboratory.  
This report must not be used by the client to claim product certification, approval, or  
endorsement by NVLAP, NIST, or any agency of the Federal Government.

Rogers Labs, Inc.	Garmin International, Inc.	SN's: CE/FCC unit1, CE/FCC unit2
4405 West 259th Terrace	Models: A03198 and B03198	FCC ID: IPH-03198
Louisburg, KS 66053	Test #: 170817	IC: 1792A-03198
Phone/Fax: (913) 837-3214	Test to: CFR47 15C, RSS-Gen RSS-247	Date: October 27, 2017
Revision 2	File: A03198 DTS TstRpt 170817 r2	Page 2 of 33

## Table Of Contents

<b>TABLE OF CONTENTS.....</b>	<b>3</b>
<b>REVISIONS.....</b>	<b>5</b>
<b>FOREWORD.....</b>	<b>6</b>
<b>OPINION / INTERPRETATION OF RESULTS .....</b>	<b>6</b>
<b>EQUIPMENT TESTED.....</b>	<b>6</b>
Equipment Function .....	7
Equipment Configuration.....	8
<b>APPLICATION FOR CERTIFICATION.....</b>	<b>9</b>
<b>APPLICABLE STANDARDS &amp; TEST PROCEDURES .....</b>	<b>10</b>
<b>EQUIPMENT TESTING PROCEDURES .....</b>	<b>10</b>
AC Line Conducted Emission Test Procedure .....	10
Radiated Emission Test Procedure.....	10
Diagram 1 Test arrangement for radiated emissions of tabletop equipment.....	11
Diagram 2 Test arrangement for radiated emissions tested on Open Area Test Site (OATS).....	12
<b>TEST SITE LOCATIONS .....</b>	<b>12</b>
<b>LIST OF TEST EQUIPMENT .....</b>	<b>13</b>
<b>UNITS OF MEASUREMENTS .....</b>	<b>14</b>
<b>ENVIRONMENTAL CONDITIONS.....</b>	<b>14</b>
<b>STATEMENT OF MODIFICATIONS AND DEVIATIONS .....</b>	<b>14</b>
<b>INTENTIONAL RADIATORS.....</b>	<b>14</b>
Antenna Requirements .....	14
Restricted Bands of Operation.....	15

Table 1 Harmonic Radiated Emissions in Restricted Bands Data (Worst-case).....15

**Summary of Results for Radiated Emissions in Restricted Bands .....16**

**General Radiated Emissions Procedure.....16**

Table 2 General Radiated Emissions Data .....17

**Summary of Results for General Radiated Emissions .....17**

**Operation in the Band 2400 – 2483.5 MHz .....18**

Figure 1 Plot of Transmitter Emissions in Operational Frequency (802.11 b-Mode) .....19

Figure 2 Plot of Transmitter Emissions in Operational Frequency (802.11 g-Mode) .....19

Figure 3 Plot of Transmitter Emissions in Operational Frequency (802.11 n-Mode) .....20

Figure 4 Plot of Lower Band Edge (802.11 b-mode) .....20

Figure 5 Plot of Lower Band Edge (802.11 g-mode) .....21

Figure 6 Plot of Lower Band Edge (802.11 n-mode) .....21

Figure 7 Plot of Upper Band Edge (802.11 b-mode).....22

Figure 8 Plot of Upper Band Edge (802.11 g-mode).....22

Figure 9 Plot of Upper Band Edge (802.11 n-mode).....23

Figure 10 Plot of Transmitter 6-dB Occupied Bandwidth (802.11 b-mode) .....23

Figure 11 Plot of Transmitter 99% Occupied Bandwidth (802.11 b-mode).....24

Figure 12 Plot of Transmitter 6-dB Occupied Bandwidth (802.11 g-mode) .....24

Figure 13 Plot of Transmitter 99% Occupied Bandwidth (802.11 g-mode).....25

Figure 14 Plot of Transmitter 6-dB Occupied Bandwidth (802.11 n-mode) .....25

Figure 15 Plot of Transmitter 99% Occupied Bandwidth (802.11 n-mode).....26

**Transmitter Emissions Data.....27**

Table 3 Transmitter Radiated Emission Worst-case Data .....27

Table 4 Transmitter Antenna Port Data .....28

**Summary of Results for Transmitter Radiated Emissions of Intentional Radiator .....28**

**ANNEX..... 29**

**Annex A Measurement Uncertainty Calculations.....30**

**Annex B Rogers Labs Test Equipment List.....31**

**Annex C Rogers Qualifications .....32**

**Annex D Rogers Labs Certificate of Accreditation.....33**

## Revisions

Revision 2 Issued October 27, 2017 – corrected type error 13 list, added Lab designation

Revision 1 Issued October 17, 2017

Rogers Labs, Inc.  
4405 West 259th Terrace  
Louisburg, KS 66053  
Phone/Fax: (913) 837-3214  
Revision 2

Garmin International, Inc.   SN's: CE/FCC unit1, CE/FCC unit2  
Models: A03198 and B03198    FCC ID: IPH-03198  
Test #: 170817                    IC: 1792A-03198  
Test to: CFR47 15C, RSS-Gen RSS-247   Date: October 27, 2017  
File: A03198 DTS TstRpt 170817 r2    Page 5 of 33

## Foreword

The following information is submitted for consideration in obtaining Grant of Certification for License Exempt Digital Transmission System Intentional Radiator operating under Code of Federal Regulations Title 47 (CFR 47) Paragraph 15.247 and Industry Canada RSS-GEN, Issue 4 and RSS-247 Issue 2, operation in the 2400 – 2483.5 MHz band.

Name of Applicant: Garmin International, Inc.  
1200 East 151st Street  
Olathe, KS 66062

M/N's: A03198 and B03198

FCC ID: IPH-03198                      Industry Canada ID: 1792A-03198

Frequency Range: 2412-2462 MHz (20 MHz channels), Average output power 0.052 W,  
Peak Power 0.280 Watts, (99% Occupied bandwidth 80.11b - 13590,  
802.11g – 17240 802.11n - 18280 kHz)

## Opinion / Interpretation of Results

Tests Performed	Margin (dB)	Results
Emissions 15.205, RSS-GEN	-17.0	Complies
Emissions as per CFR 47 paragraphs 2 and 15.207	N/A	Complies
Emissions as per CFR 47 paragraphs 2 and 15.209	-2.0	Complies
Harmonic Emissions per CFR 47 15.247	-13.3	Complies
Peak Power Spectral Density per CFR 47 15.247	-0.65	Complies

## Equipment Tested

<u>Equipment</u>	<u>Model / PN</u>	<u>Serial Number</u>
EUT	A03198	CE/FCC unit1
EUT #2	A03198	CE/FCC unit2
Transducer (SONAR)	GT 52HW-TM	4P2024962
Panoptix (network)	PS21	4PG000073
Interface cable	NMEA 2000	N/A
Power Cable	N/A	N/A

Test results in this report relate only to the items tested.

Rogers Labs, Inc.	Garmin International, Inc.	SN's: CE/FCC unit1, CE/FCC unit2
4405 West 259th Terrace	Models: A03198 and B03198	FCC ID: IPH-03198
Louisburg, KS 66053	Test #: 170817	IC: 1792A-03198
Phone/Fax: (913) 837-3214	Test to: CFR47 15C, RSS-Gen RSS-247	Date: October 27, 2017
Revision 2	File: A03198 DTS TstRpt 170817 r2	Page 6 of 33

## ***Equipment Function***

The EUT is a mobile mounted device providing display and operational control of the Sound Navigation and Ranging (SONAR) and/or Panoptix transducer inputs, location and navigational aid, and incorporates wireless transmitter functions for communications with compatible equipment in marine installations. The design is incorporated in two display options seven or nine inch using the identical printed circuit board. The transmitters provide operation capability in the 2402-2480 MHz frequency band. The design provides wireless communications in three modes (mode 1 ANT, mode 2 BlueTooth®, and mode 3 Wi-Fi) providing wireless interface capabilities with compatible equipment. The device communicates with interfaced equipment providing graphical display of the presented information. The EUT offers no other interface connections than those in the configuration options as described by the manufacturer and shown below. The EUT operates from external power received through vehicle installation. The EUT was arranged in the manufacturer defined testing configuration for testing purposes. The design utilizes internal fixed antenna systems and offers no provision for antenna replacement or modification. Two samples were provided for testing, one representative of production design, and the other modified for testing purposes replacing integral antenna with RF connection port. The test samples were provided with test software enabling testing personnel the ability to enable transmitter functions on defined channels. The antenna modification offered testing facility ability to connect test equipment to the temporary antenna port for antenna port conducted emission testing. The EUT was arranged as described by the manufacturer emulating typical user configurations for testing purposes. For testing purposes, the EUT received powered from direct current bench power supply and configured to operate in available modes. As requested by the manufacturer and required by regulations, the equipment was tested for emissions compliance using the available configurations with the worst-case data presented. This report documents compliance testing and results for applicable product modes of operation. Test results in this report relate only to the products described in this report.

## Equipment Configuration

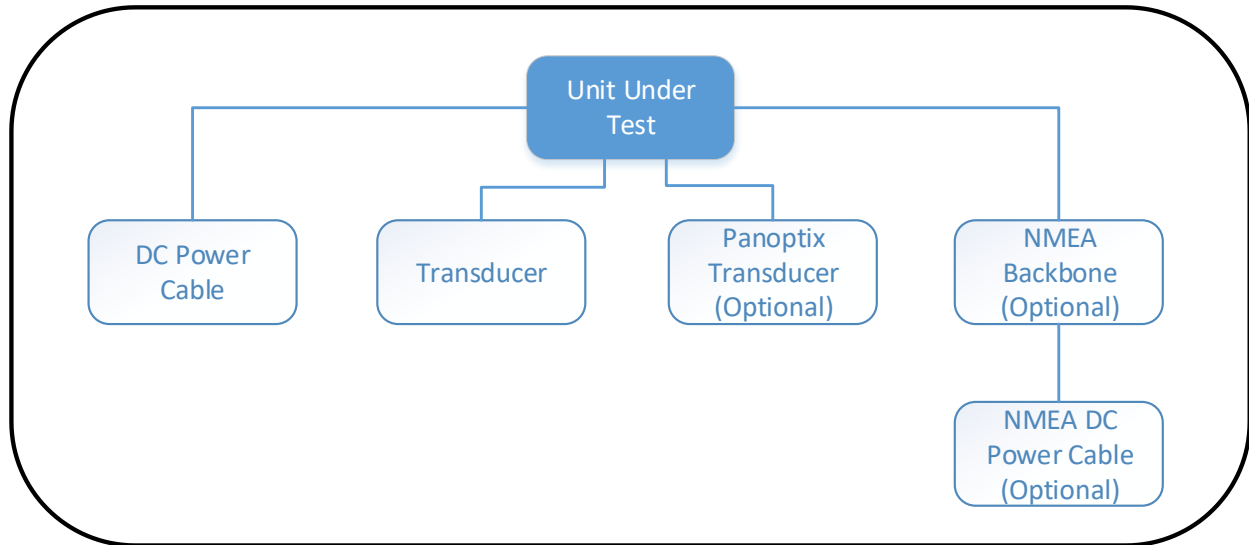



## Application for Certification

- (1) Manufacturer: Garmin International, Inc.  
1200 East 151st Street  
Olathe, KS 66062
- (2) Identification: M/N's: A03198 and B03198  
FCC ID: IPH-03198 IC: 1792A-03198
- (3) Instruction Book:  
Refer to Exhibit for Instruction Manual.
- (4) Description of Circuit Functions:  
Refer to Exhibit of Operational Description.
- (5) Block Diagram with Frequencies:  
Refer to Exhibit of Operational Description.
- (6) Report of Measurements:  
Report of measurements follows in this Report.
- (7) Photographs: Construction, Component Placement, etc.:  
Refer to Exhibit for photographs of equipment.
- (8) List of Peripheral Equipment Necessary for operation. The equipment operates from direct current power provided from installation vehicle only. The design provides interface ports for connection with DC power, NMEA 2000, SONAR, and Garmin Marine Network. The SONAR interface cable passed twice through a Ferrite Bead. The EUT offers no other power option or connection ports than those presented in this filing.
- (9) Transition Provisions of CFR47 15.37 are not requested.
- (10) Not Applicable. The unit is not a scanning receiver.
- (11) Not Applicable. The EUT does not operate in the 59 – 64 GHz frequency band.
- (12) The equipment is not software defined and this section is not applicable.
- (13) Applications for certification of U-NII devices in the 5.15-5.35 GHz and the 5.47-5.85 GHz bands must include a high-level operational description of the security procedures that control the radio frequency operating parameters and ensure that unauthorized modifications cannot be made. This requirement is not applicable to his DTS device.
- (14) Contain at least one drawing or photograph showing the test set-up for each of the required types of tests applicable to the device for which certification is requested. These drawings or photographs must show enough detail to confirm other information contained in the test report. Any photographs used must be focused originals without glare or dark spots and must clearly show the test configuration used. This information is provided in this report and Test Setup Exhibits provided with the application filing.

## Applicable Standards & Test Procedures

The following information is submitted in accordance with the Federal Communications Code of Federal Regulations, dated August 17, 2017, Part 2, Subpart J, Paragraphs 2.907, 2.911, 2.913, 2.925, 2.926, 2.1031 through 2.1057, and applicable parts of paragraph 15, Part 15C Paragraph 15.247, and Industry Canada RSS-GEN Issue 4, and RSS-247 Issue 2. Test procedures used are the established Methods of Measurement of Radio-Noise Emissions as described in ANSI C63.10-2013.

## Equipment Testing Procedures

### ***AC Line Conducted Emission Test Procedure***

The EUT operates solely from direct current power supplied from installation vehicle. Therefore, no AC line conducted emissions testing was required or performed.

### ***Radiated Emission Test Procedure***

The EUT was placed on a rotating 0.9 x 1.2-meter platform, elevated as required above the ground plane at a distance of 3 meters from the FSM antenna. Radiated emissions testing was performed as required in CFR47 15, RSS-247 and specified in ANSI C63.10-2013. EMI energy was maximized by equipment placement permitting orientation in three orthogonal axes, raising and lowering the FSM antenna, changing the antenna polarization, and by rotating the turntable. Each emission was maximized before data was taken using a spectrum analyzer. The frequency spectrum from 9 kHz to 25,000 MHz was searched for during preliminary investigation. Refer to diagrams two and three showing typical test arrangement and photographs in the test setup exhibits for specific EUT placement during testing.

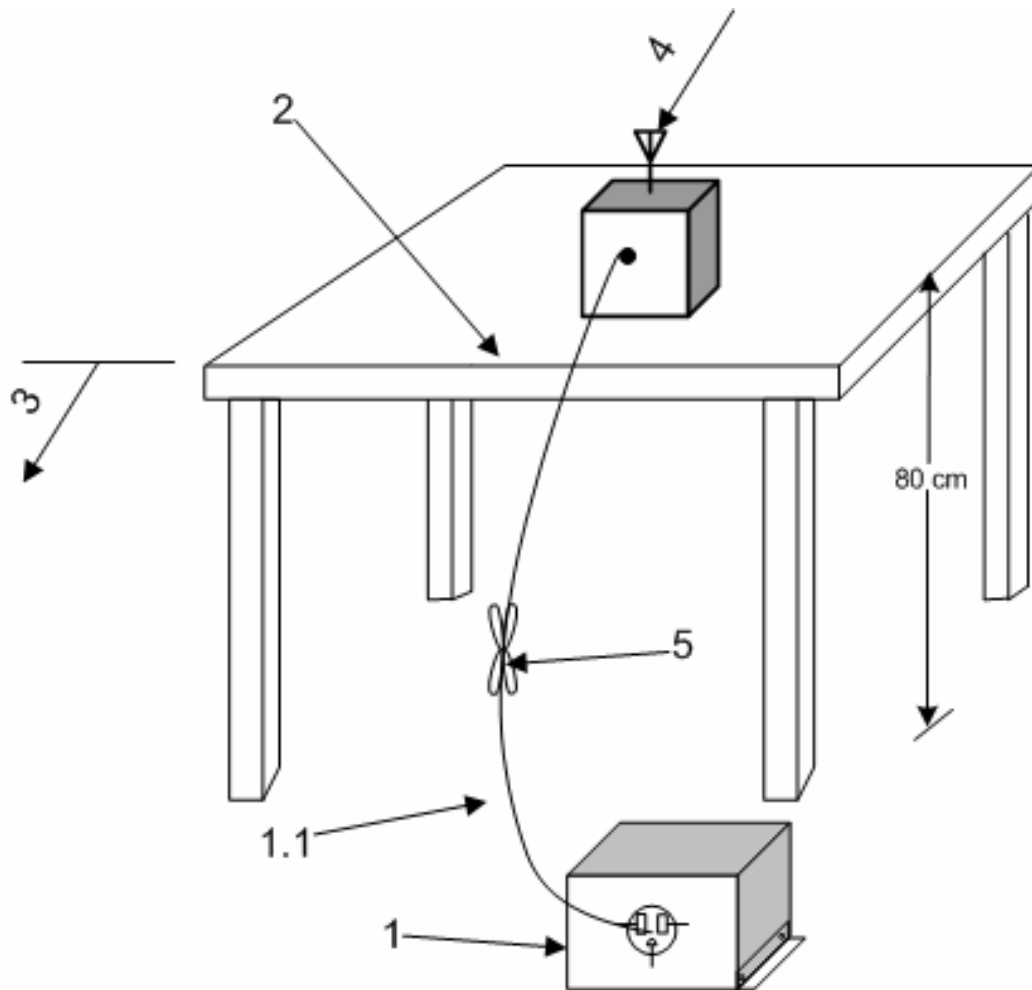

1. A LISN is optional for radiated measurements between 30 MHz to 1000 MHz, but not allowed for measurements below 30 MHz and above 1000 MHz. (See 6.4.3, 6.5.1, and 6.6.3.) If used, connect EUT to one LISN. Unused LISN measuring port connectors shall be terminated in 50Ω. LISN can be placed on top of, or immediately beneath, reference ground plane (see 6.2.2 and 6.2.3.1).
  - 1.1 LISN spaced at least 80 cm from nearest part of EUT chassis.
2. The EUT shall be placed in the center of the table to the extent possible. (See 6.2.3.1 and 6.3.4).
3. A vertical conducting plane, if used for conducted tests per 6.2.2, shall be removed for radiated emission tests.
4. Antenna may be integral or detachable, depending on the EUT.
5. Interconnecting cables that hang closer than 40 cm to the ground plane shall be folded back and forth in the center forming a bundle 30 cm to 40 cm long.

**Diagram 1 Test arrangement for radiated emissions of tabletop equipment**

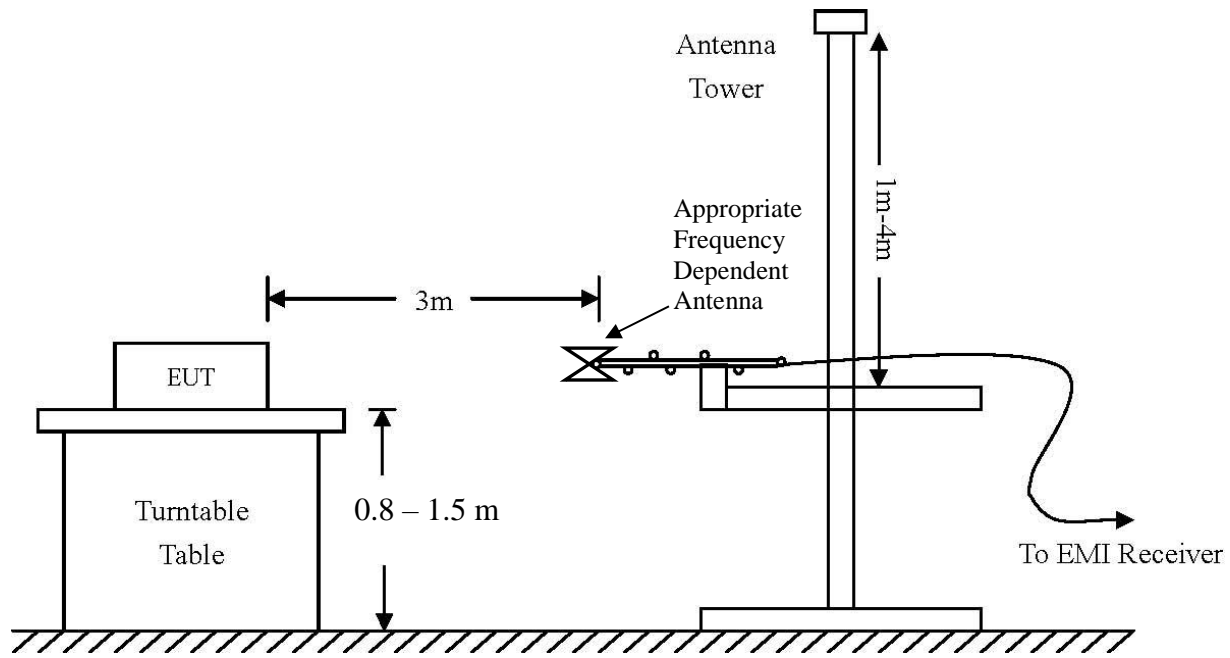

**Diagram 2 Test arrangement for radiated emissions tested on Open Area Test Site (OATS)**

## Test Site Locations

**Conducted EMI**      The AC power line conducted emissions testing performed in a shielded screen room located at Rogers Labs, Inc., 4405 West 259<sup>th</sup> Terrace, Louisburg, KS

**Radiated EMI**      The radiated emissions tests were performed at the 3 meters, Open Area Test Site (OATS) located at Rogers Labs, Inc., 4405 West 259<sup>th</sup> Terrace, Louisburg, KS

**Site Registration**      Refer to Annex for Site Registration Letters

**NVLAP Accreditation**      Lab code 200087-0

## List of Test Equipment

A Rohde and Schwarz ESU40 and/or Hewlett Packard 8591EM was used as the measuring device for the emissions testing of frequencies below 1 GHz. A Rohde and Schwarz ESU40 and/or Hewlett Packard 8562A Spectrum Analyzer was used as the measuring device for testing the emissions at frequencies above 1 GHz. The analyzer settings used are described in the following table. Refer to the appendix for a complete list of test equipment.

AC Line Conducted Emissions (0.150 -30 MHz)		
RBW	AVG. BW	Detector Function
9 kHz	30 kHz	Peak / Quasi Peak
Emissions (30-1000 MHz)		
RBW	AVG. BW	Detector Function
120 kHz	300 kHz	Peak / Quasi Peak
Emissions (Above 1000 MHz)		
RBW	Video BW	Detector Function
100 kHz	100 kHz	Peak
1 MHz	1 MHz	Peak / Average

<u>Equipment</u>	<u>Manufacturer</u>	<u>Model (SN)</u>	<u>Band</u>	<u>Cal Date</u>	<u>Due</u>
<input type="checkbox"/> LISN	FCC	FCC-LISN-50-2-10(1PA) (160611)	.15-30MHz	5/17	5/18
<input checked="" type="checkbox"/> Cable	Time Microwave	750HF290-750 (L10M)	9kHz-40 GHz	10/16	10/17
<input type="checkbox"/> Cable	Belden	RG-58 (L1-CAT3-11509)	9kHz-30 MHz	10/16	10/17
<input type="checkbox"/> Cable	Belden	RG-58 (L2-CAT3-11509)	9kHz-30 MHz	10/16	10/17
<input type="checkbox"/> Antenna	ARA	BCD-235-B (169)	20-350MHz	10/16	10/17
<input type="checkbox"/> Antenna	EMCO	3147 (40582)	200-1000MHz	10/16	10/17
<input checked="" type="checkbox"/> Antenna	ETS-Lindgren	3117 (200389)	1-18 GHz	5/17	5/18
<input type="checkbox"/> Antenna	Com Power	AH-118 (10110)	1-18 GHz	10/15	10/17
<input checked="" type="checkbox"/> Antenna	Com Power	AH-840 (101046)	18-40 GHz	5/17	5/18
<input checked="" type="checkbox"/> Antenna	Com Power	AL-130 (121055)	.001-30 MHz	10/16	10/17
<input checked="" type="checkbox"/> Antenna	Sunol	JB-6 (A100709)	30-1000 MHz	10/16	10/17
<input type="checkbox"/> Antenna	EMCO	3143 (9607-1277)	20-1200 MHz	5/17	5/18
<input type="checkbox"/> Analyzer	HP	8591EM (3628A00871)	9kHz-1.8GHz	5/17	5/18
<input type="checkbox"/> Analyzer	HP	8562A (3051A05950)	9kHz-110GHz	5/17	5/18
<input type="checkbox"/> Analyzer	HP External Mixers	11571, 11970	25GHz-110GHz	5/17	5/18
<input checked="" type="checkbox"/> Analyzer	Rohde & Schwarz	ESU40 (100108)	20Hz-40GHz	5/17	5/18
<input checked="" type="checkbox"/> Amplifier	Com-Power	PA-010 (171003)	100Hz-30MHz	10/16	10/17
<input checked="" type="checkbox"/> Amplifier	Com-Power	CPPA-102 (01254)	1-1000 MHz	10/16	10/17
<input checked="" type="checkbox"/> Amplifier	Com-Power	PAM-118A (551014)	0.5-18 GHz	10/16	10/17
<input checked="" type="checkbox"/> Power Mtr	Agilent	N1911A with N1921A	0.05-18 GHz	5/17	5/18

Rogers Labs, Inc.	Garmin International, Inc.	SN's: CE/FCC unit1, CE/FCC unit2
4405 West 259th Terrace	Models: A03198 and B03198	FCC ID: IPH-03198
Louisburg, KS 66053	Test #: 170817	IC: 1792A-03198
Phone/Fax: (913) 837-3214	Test to: CFR47 15C, RSS-Gen RSS-247	Date: October 27, 2017
Revision 2	File: A03198 DTS TstRpt 170817 r2	Page 13 of 33

## Units of Measurements

Conducted EMI            Data is in dB $\mu$ V; dB referenced to one microvolt

Radiated EMI            Data is in dB $\mu$ V/m; dB/m referenced to one microvolt per meter

Sample Calculation:

RFS = Radiated Field Strength, FSM = Field Strength Measured

A.F. = Receive antenna factor, Gain = amplification gains and/or cable losses

RFS (dB $\mu$ V/m @ 3m) = FSM (dB $\mu$ V) + A.F. (dB) - Gain (dB)

## Environmental Conditions

Ambient Temperature            24.2° C

Relative Humidity                43%

Atmospheric Pressure            1007.2 mb

## Statement of Modifications and Deviations

No modifications to the EUT were required for the unit to demonstrate compliance with the CFR47 Part 15C, RSS-Gen, and RSS-247 emission requirements. There were no deviations to the specifications.

## Intentional Radiators

As per CFR47, Subpart C, paragraph 15.247 and Industry Canada RSS-247 and RSS-Gen the following information is submitted.

## Antenna Requirements

The EUT incorporates integral antenna system and offers no provision for connection to alternate antenna system. The antenna connection point complies with the unique antenna connection requirements. There are no deviations or exceptions to the specification.

## Restricted Bands of Operation

Spurious emissions falling in the restricted frequency bands of operation were measured at the OATS. The EUT utilizes frequency, determining circuitry, which generates harmonics falling in the restricted bands. Emissions were investigated at the OATS, using appropriate antennas or pyramidal horns, amplification stages, and a spectrum analyzer. Peak and average amplitudes of frequencies above 1000 MHz were compared to the required limits with worst-case data presented below. Test procedures of ANSI C63.10-2013 paragraph 6 and KDB 558074 paragraph 10.2 were used during testing. No other significant emission was observed which fell into the restricted bands of operation. Computed emission values consider the received radiated field strength, receive antenna correction factor, amplifier gain stage, and test system cable losses.

**Table 1 Harmonic Radiated Emissions in Restricted Bands Data (Worst-case)**

Frequency in MHz	Horizontal Peak (dB $\mu$ V/m)	Horizontal Quasi-Peak (dB $\mu$ V/m)	Horizontal Average (dB $\mu$ V/m)	Vertical Peak (dB $\mu$ V/m)	Vertical Quasi-Peak (dB $\mu$ V/m)	Vertical Average (dB $\mu$ V/m)	Limit @ 3m (dB $\mu$ V/m)
2390.0	59.4	N/A	33.5	58.5	N/A	31.3	54.0
2483.5	47.8	N/A	31.1	57.7	N/A	32.4	54.0
4824.0	45.2	N/A	32.0	44.8	N/A	31.7	54.0
4874.0	45.9	N/A	32.2	44.3	N/A	31.4	54.0
4924.0	45.0	N/A	31.7	44.8	N/A	31.9	54.0
7236.0	46.0	N/A	33.4	46.1	N/A	33.8	54.0
7311.0	46.0	N/A	32.9	45.9	N/A	32.9	54.0
7386.0	45.3	N/A	32.9	46.1	N/A	33.3	54.0
12060.0	50.2	N/A	37.0	49.9	N/A	36.8	54.0
12185.0	48.3	N/A	35.8	48.3	N/A	35.9	54.0
12310.0	48.5	N/A	35.8	48.5	N/A	35.5	54.0

Other emissions present had amplitudes at least 20 dB below the limit. Peak and Quasi-Peak amplitude emissions are recorded for frequency below 1000 MHz. Peak and Average amplitude emissions are recorded for frequency range above 1000 MHz.

## **Summary of Results for Radiated Emissions in Restricted Bands**

The EUT demonstrated compliance with the radiated emissions requirements of CFR 47 Part 15C RSS-Gen, and RSS-247 Intentional Radiators. The EUT demonstrated a worst-case minimum harmonic margin of -17.0 dB below the radiated emissions requirements in restricted frequency bands. Peak, Quasi-peak, and average amplitudes were checked for compliance with the regulations. Worst-case emissions are reported with other emissions found in the restricted frequency bands at least 20 dB below the requirements.

## **General Radiated Emissions Procedure**

The EUT was arranged in a typical equipment configuration and operated through all available mode during testing. Preliminary testing was performed in a screen room with the EUT positioned 1 meter from the FSM. Radiated emissions measurements were performed to identify the frequencies, which produced the highest emissions. Each radiated emission was then maximized at the OATS location before final radiated measurements were performed. Final data was taken with the EUT located on the OATS at 3 meters distance between the EUT and the receiving antenna. The frequency spectrum from 9 kHz to 25,000 MHz was searched for general radiated emissions. Measured emission levels were maximized by EUT placement on the table, rotating the turntable through 360 degrees, varying the antenna height between 1 and 4 meters above the ground plane and changing antenna position between horizontal and vertical polarization. Antennas used were Loop from 9 kHz to 30 MHz, Broadband Biconical from 30 to 200 MHz, Biconilog from 30 to 1000 MHz, Log Periodic from 200 MHz to 1 GHz and or double Ridge or pyramidal horns and mixers above 1 GHz, notch filters and appropriate amplifiers and external mixers were utilized.



**Table 2 General Radiated Emissions Data**

Frequency in MHz	Horizontal Peak (dBµV/m)	Horizontal Quasi-Peak (dBµV/m)	Horizontal Average (dBµV/m)	Vertical Peak (dBµV/m)	Vertical Quasi-Peak (dBµV/m)	Vertical Average (dBµV/m)	Limit @ 3m (dBµV/m)
42.3	44.5	36.9	N/A	38.3	29.7	N/A	40.0
54.2	38.2	31.2	N/A	35.3	29.8	N/A	40.0
54.3	38.9	30.7	N/A	37.1	30.2	N/A	40.0
68.1	40.4	32.5	N/A	46.1	38.0	N/A	40.0
69.4	37.9	30.5	N/A	43.5	36.7	N/A	40.0
69.5	40.0	32.3	N/A	44.1	38.0	N/A	40.0
69.6	39.0	31.4	N/A	42.0	36.8	N/A	40.0
69.7	38.6	31.7	N/A	42.3	34.9	N/A	40.0
71.8	45.2	36.5	N/A	35.2	27.2	N/A	40.0
73.5	41.2	32.3	N/A	38.2	29.4	N/A	40.0
86.0	39.0	30.4	N/A	45.8	37.6	N/A	40.0
86.7	36.6	27.6	N/A	42.5	34.6	N/A	40.0
100.6	36.0	30.2	N/A	33.4	28.2	N/A	40.0
131.2	32.4	24.2	N/A	37.1	26.5	N/A	40.0
145.3	33.7	28.9	N/A	30.0	26.1	N/A	40.0
146.8	35.2	30.0	N/A	33.6	27.9	N/A	40.0
158.0	32.8	27.5	N/A	33.3	29.0	N/A	40.0
158.3	32.3	28.7	N/A	32.6	29.2	N/A	40.0
178.5	38.6	35.2	N/A	33.2	29.4	N/A	40.0
180.2	37.7	35.0	N/A	33.8	30.1	N/A	40.0
181.7	37.6	34.2	N/A	33.6	29.7	N/A	40.0
205.0	38.0	32.3	N/A	31.0	25.5	N/A	40.0

Other emissions present had amplitudes at least 20 dB below the limit. Peak and Quasi-Peak amplitude emissions are recorded for frequency range below 1000 MHz. Peak and Average amplitude emissions are recorded for frequency range above 1000 MHz.

**Summary of Results for General Radiated Emissions**

The EUT demonstrated compliance with the radiated emissions requirements of CFR47 Part 15C paragraph 15.209, RSS-210 and RSS-GEN Intentional Radiators. The EUT demonstrated a minimum margin of -2.0 dB below the requirements. Other emissions were present with amplitudes at least 20 dB below the Limits.

**Operation in the Band 2400 – 2483.5 MHz**

Test procedures of ANSI C63.10-2013 paragraph 6, and KDB 558074 v04 were used during transmitter testing. The transmitter peak power was measured at the antenna port using a wide band peak RF power meter as described in KDB 558074 (9.1.2). The Peak Power Spectral Density (PKPSD) was measured as defined in KDB 558074 (10.2). Emission bandwidth was measured as described in KDB 558074 paragraph 8, and C63.10-2013. The amplitude of each harmonic and general radiated emission was measured on the OATS at distance of 3 meters from the FSM antenna (testing was performed on sample 1 representative of production equipment with integral antenna). The EUT was positioned on supporting turntable elevated as required above the ground plane, at a distance of 3 meters from the FSM antenna. Radiated emission investigations were performed from 9 kHz to 25,000 MHz. Each radiated emission was maximized by varying the FSM antenna height and polarization, and by rotating the turntable. The worst-case amplitude of each emission was then recorded from the analyzer display. The peak and quasi-peak amplitude of frequencies below 1000 MHz were measured using a spectrum analyzer. The peak and average amplitude of frequencies above 1000 MHz were measured using a spectrum analyzer. A Loop antenna was used for measuring emissions from 0.009 to 30 MHz, Biconilog Antenna for 30 to 1000 MHz, Double-Ridge, and/or Pyramidal Horn Antennas from 1 GHz to 25 GHz. Radiated Emissions were measured in dB $\mu$ V/m @ 3 meters. Test sample #2 was provided for testing antenna port conducted emissions. This sample was modified by replacing the internal antenna with a 50-ohm antenna port connector for testing purposes. Plots were taken of transmitter performance (using sample #2) for reference in this and other documentation.

Refer to figures one through fifteen showing plots taken of the transmitter performance displaying compliance with the specifications.

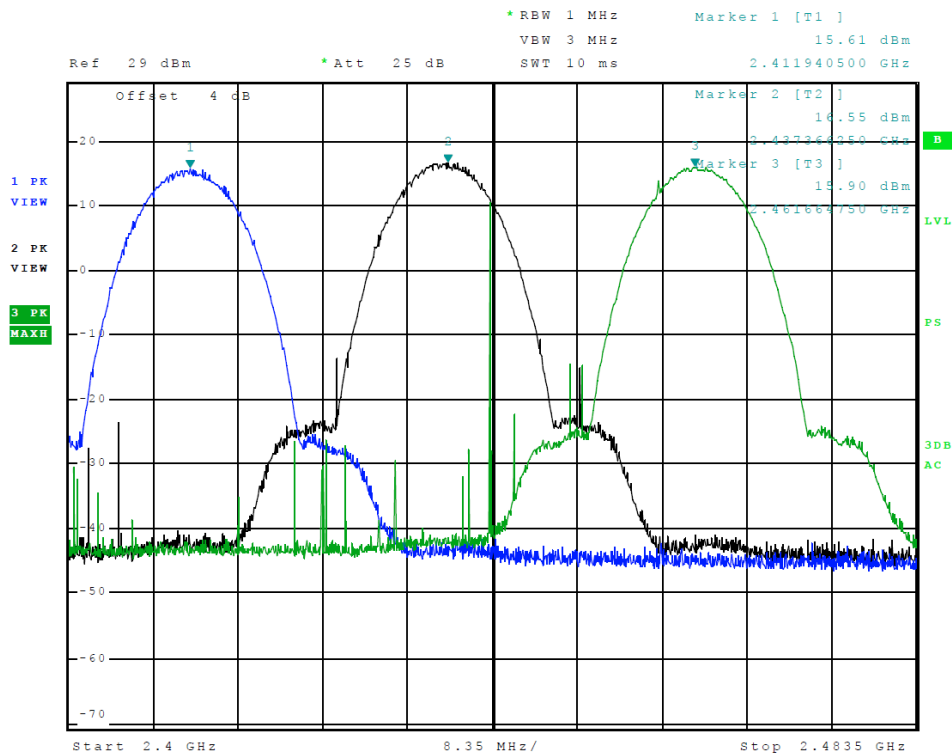

Figure 1 Plot of Transmitter Emissions in Operational Frequency (802.11 b-Mode)

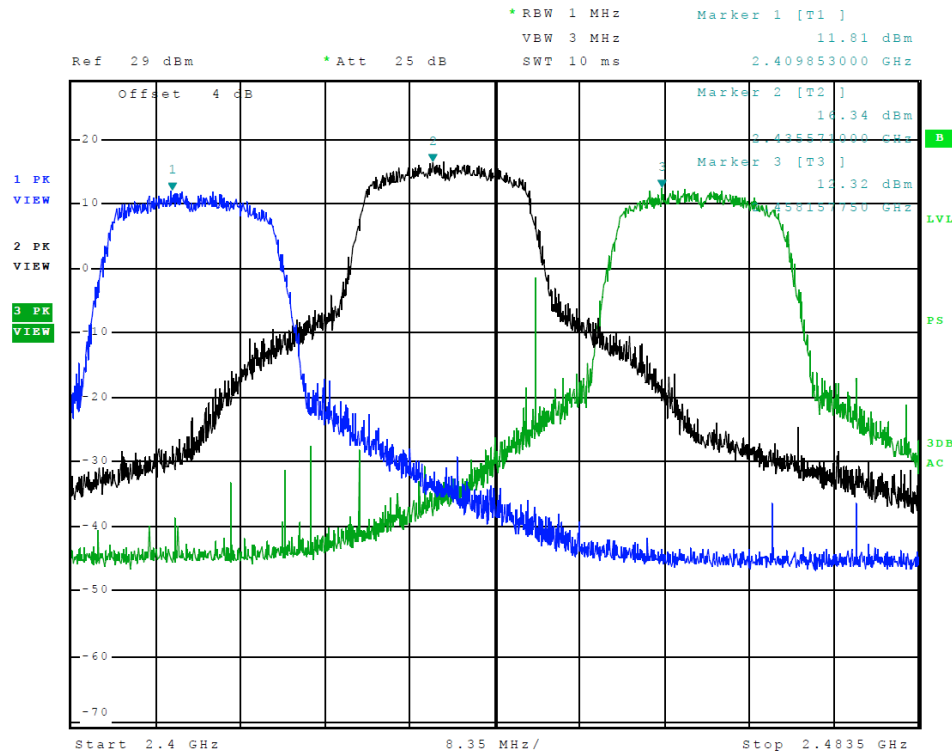

Figure 2 Plot of Transmitter Emissions in Operational Frequency (802.11 g-Mode)

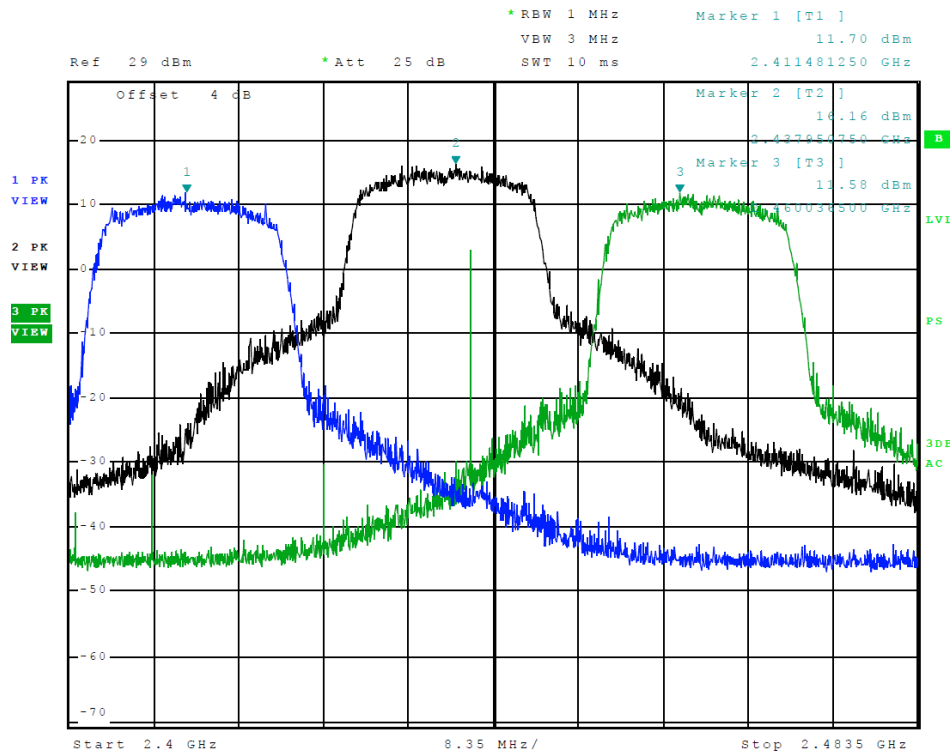

Figure 3 Plot of Transmitter Emissions in Operational Frequency (802.11 n-Mode)

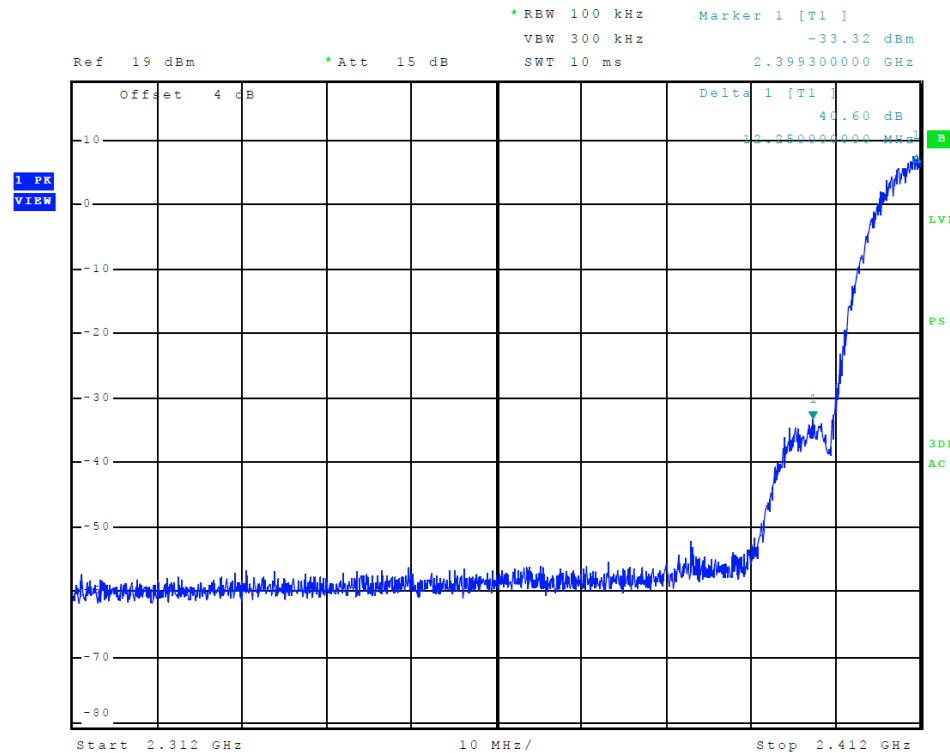

Figure 4 Plot of Lower Band Edge (802.11 b-mode)

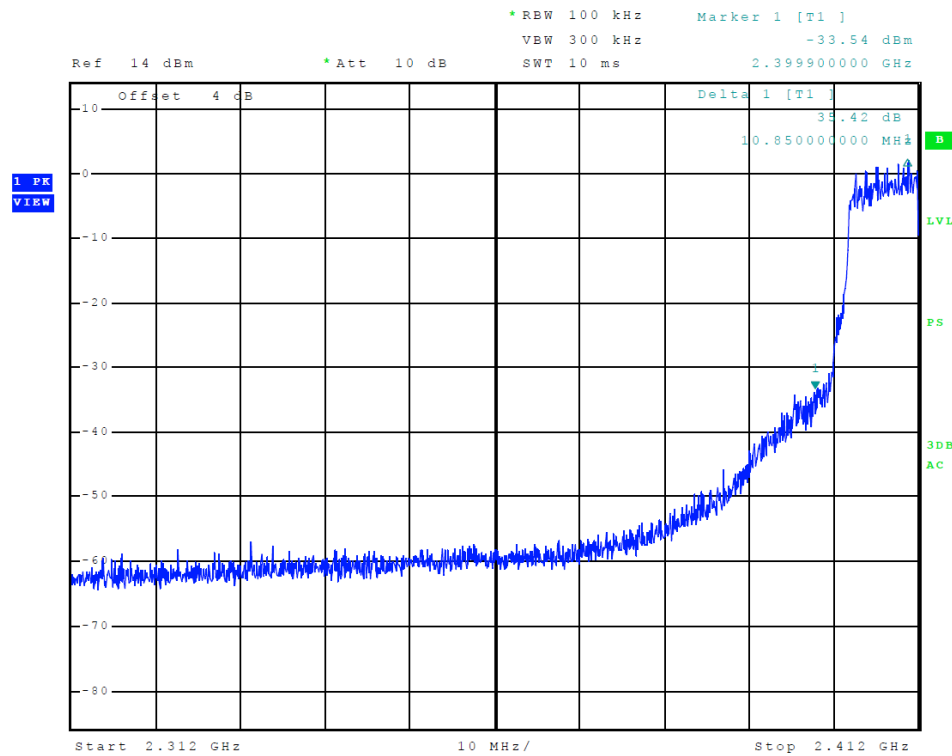

Figure 5 Plot of Lower Band Edge (802.11 g-mode)

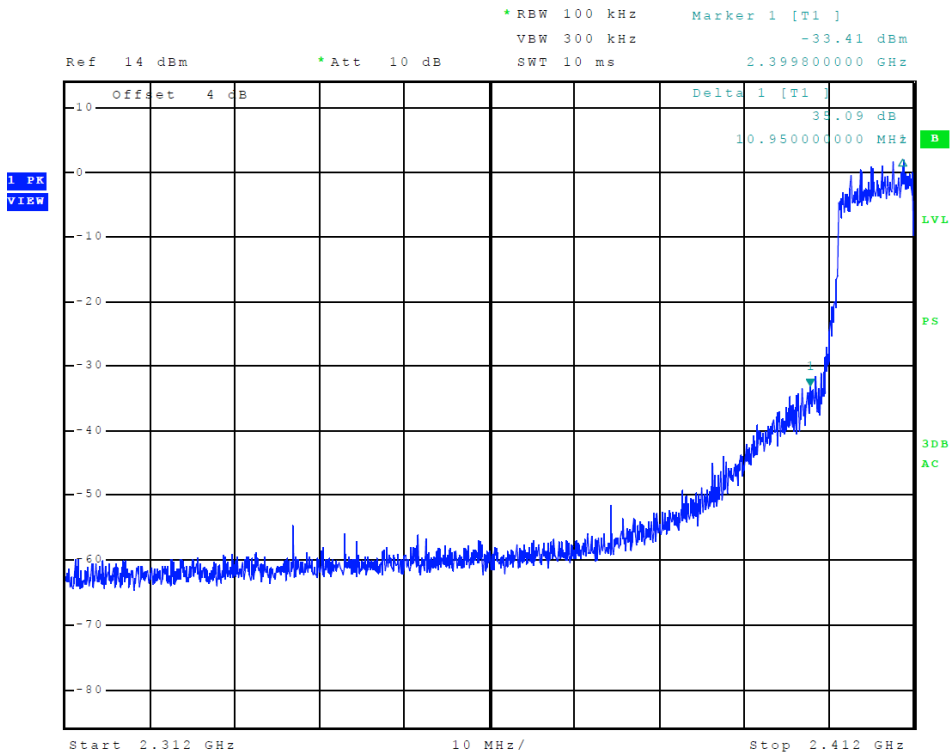
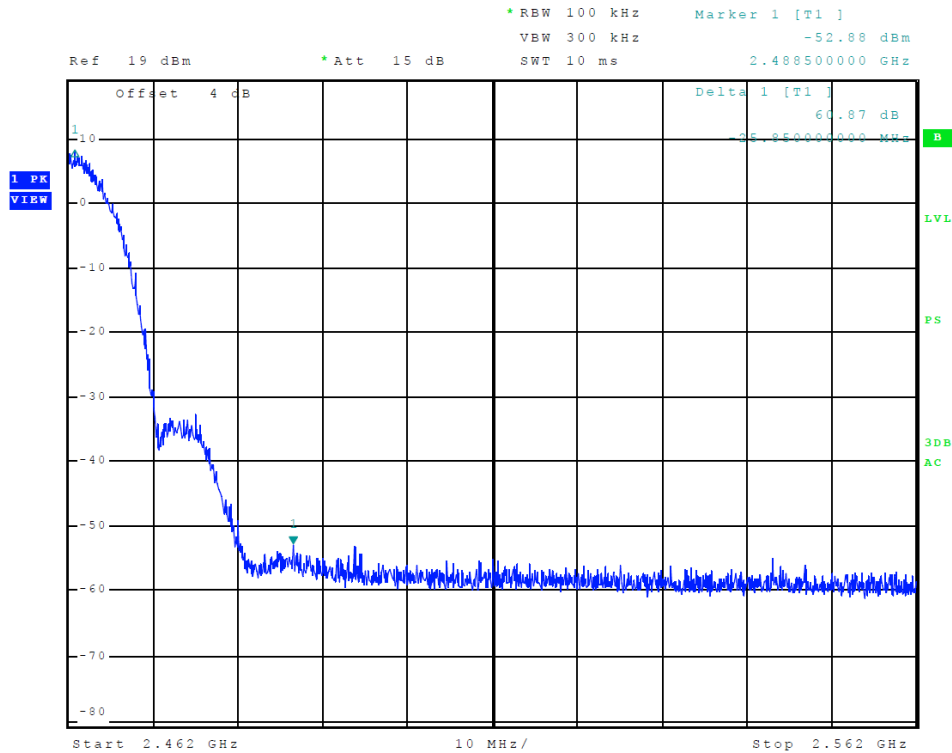
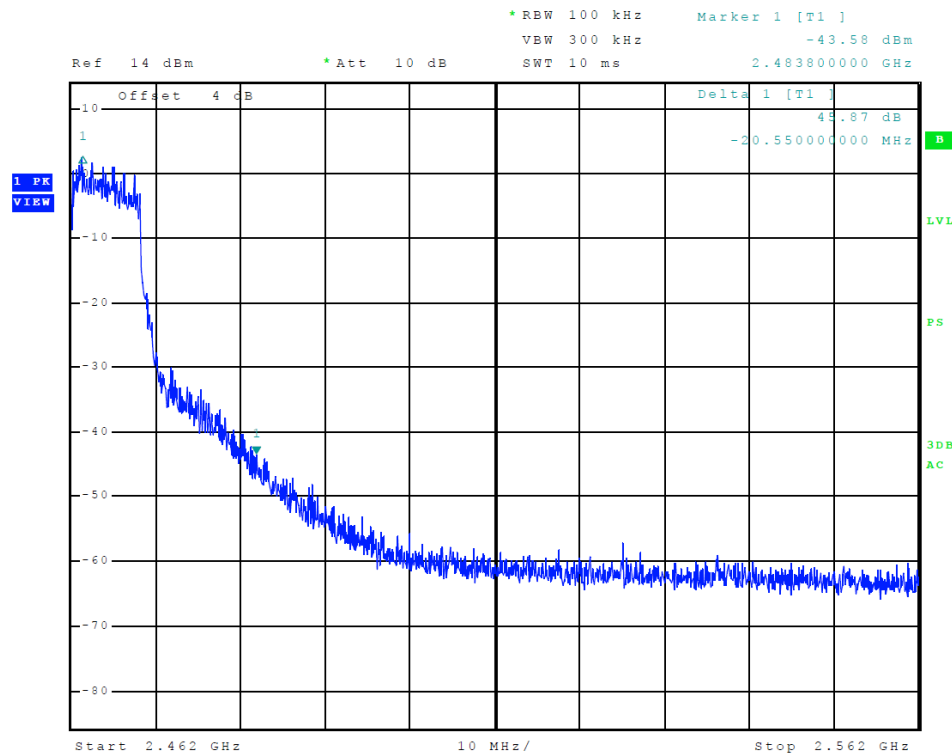

Figure 6 Plot of Lower Band Edge (802.11 n-mode)



**Figure 7 Plot of Upper Band Edge (802.11 b-mode)**



**Figure 8 Plot of Upper Band Edge (802.11 g-mode)**

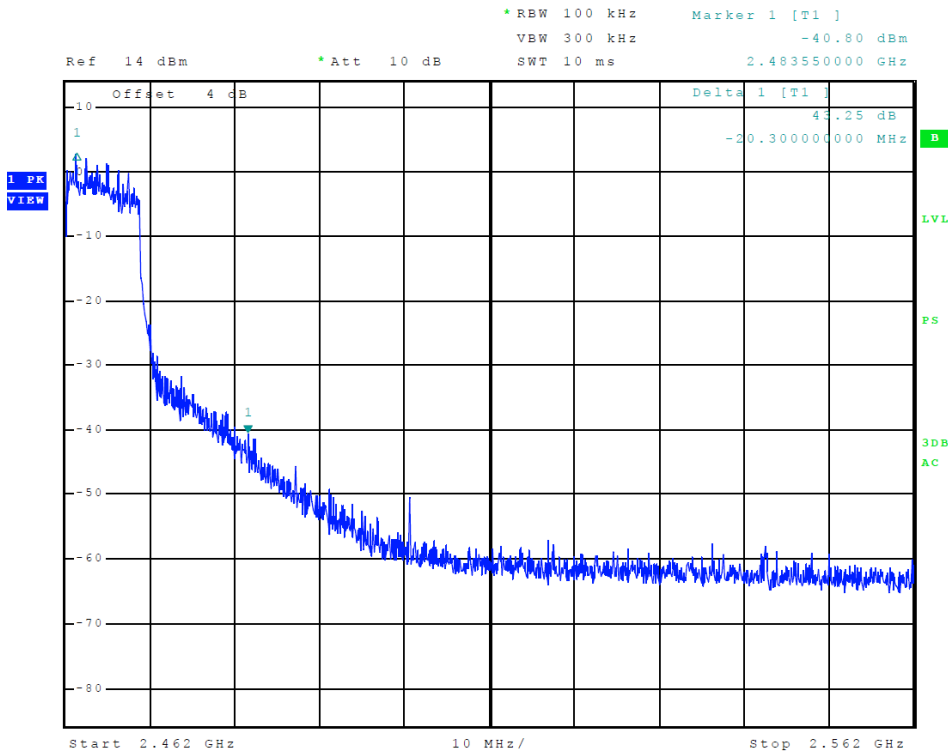

**Figure 9 Plot of Upper Band Edge (802.11 n-mode)**

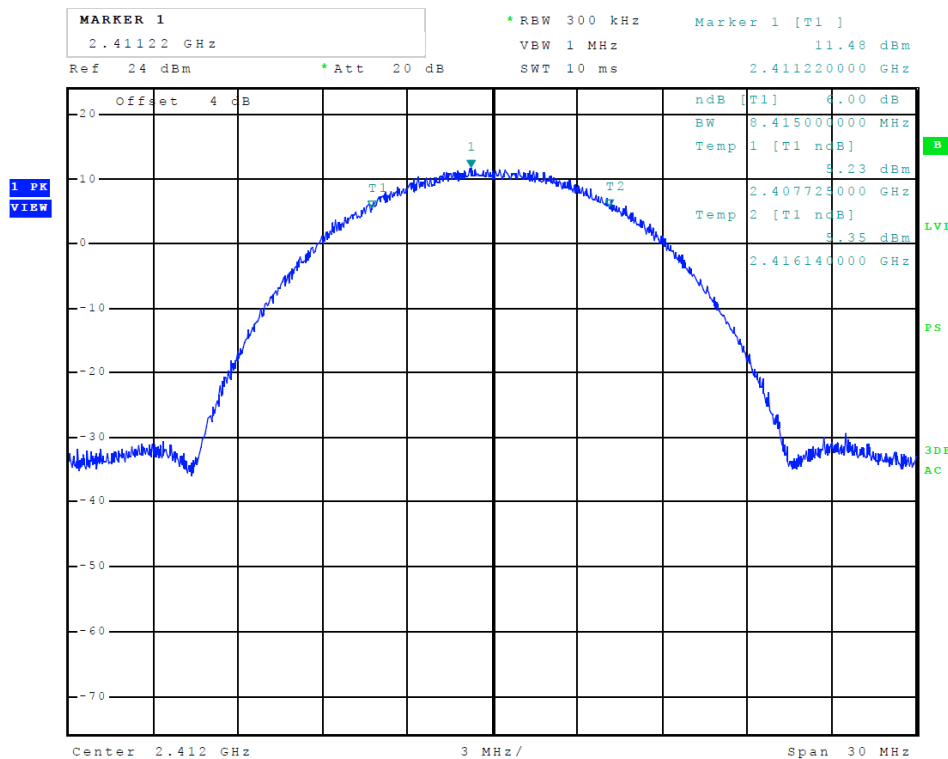

**Figure 10 Plot of Transmitter 6-dB Occupied Bandwidth (802.11 b-mode)**

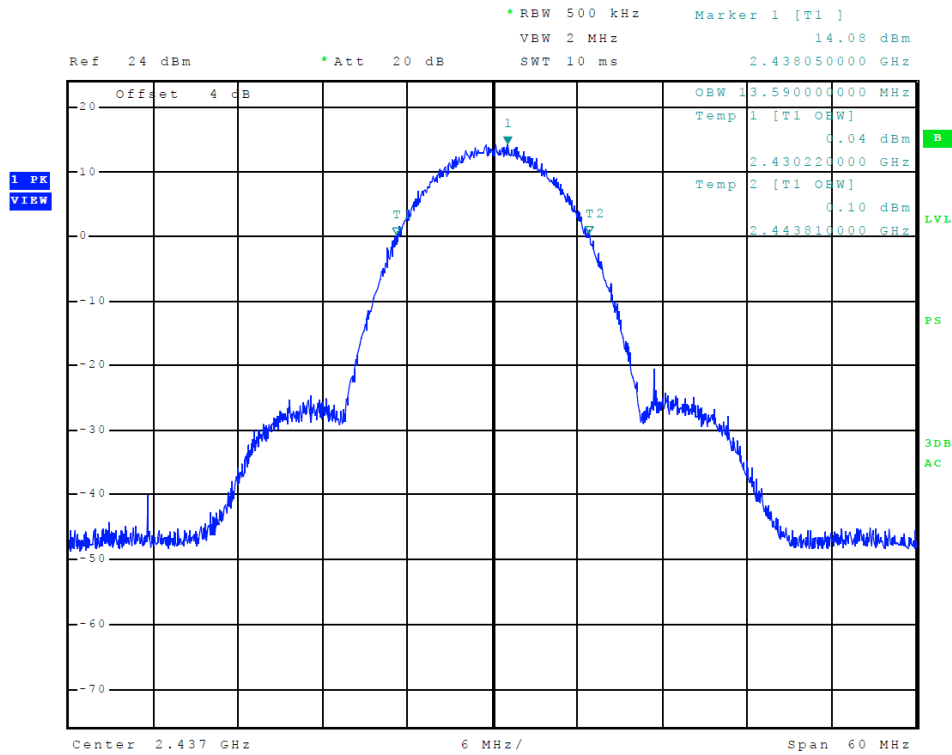

Figure 11 Plot of Transmitter 99% Occupied Bandwidth (802.11 b-mode)

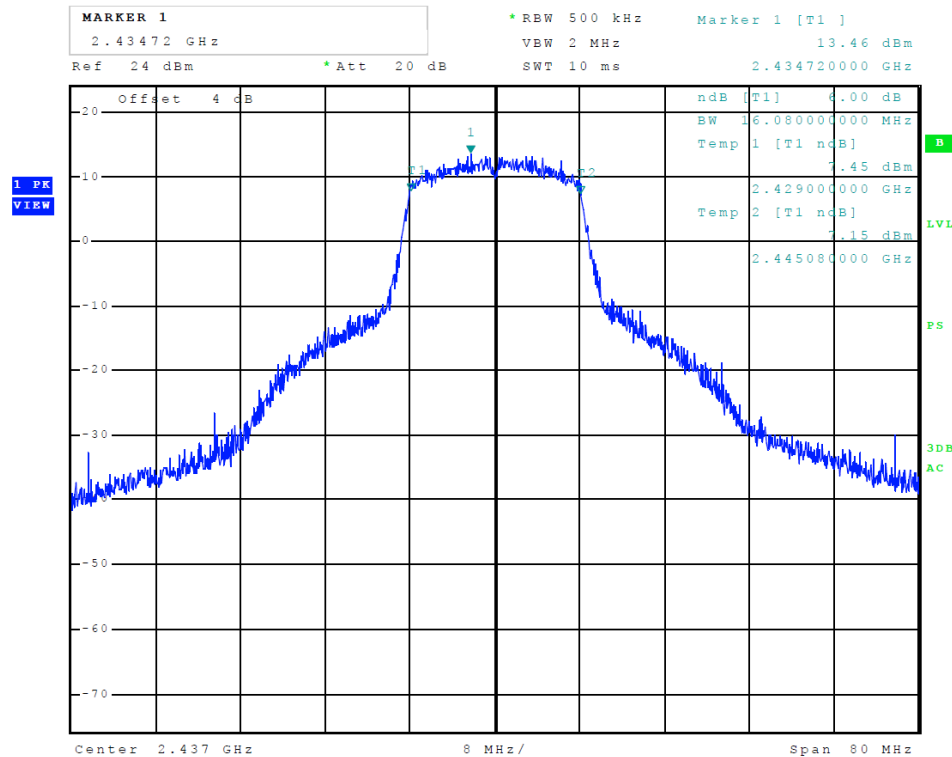
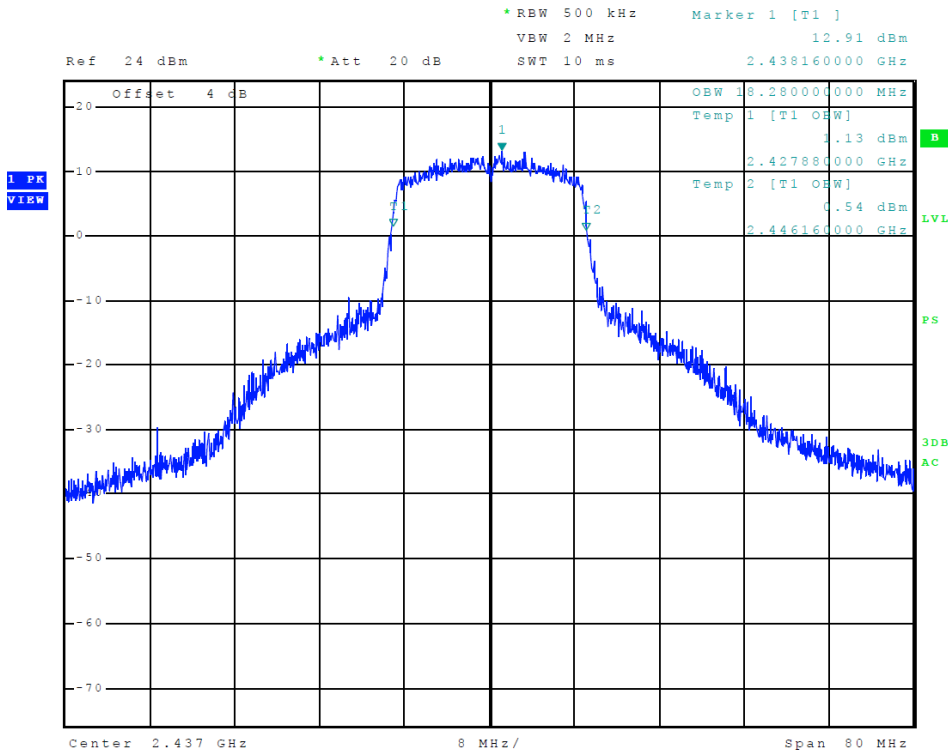

Figure 12 Plot of Transmitter 6-dB Occupied Bandwidth (802.11 g-mode)







**Figure 15 Plot of Transmitter 99% Occupied Bandwidth (802.11 n-mode)**

**Transmitter Emissions Data**

**Table 3 Transmitter Radiated Emission Worst-case Data**

Frequency in MHz	Horizontal Peak (dBµV/m)	Horizontal Average (dBµV/m)	Vertical Peak (dBµV/m)	Vertical Average (dBµV/m)	Limit @ 3m (dBµV/m)
2412.0	--	--	--	--	--
4824.0	45.2	32.0	44.8	31.7	54.0
7236.0	46.0	33.4	46.1	33.8	54.0
9648.0	46.2	33.3	45.6	33.1	54.0
12060.0	50.2	37.0	49.9	36.8	54.0
14472.0	49.0	36.5	49.1	36.4	54.0
16884.0	52.8	39.9	52.7	39.9	54.0
2437.0	--	--	--	--	--
4874.0	45.9	32.2	44.3	31.4	54.0
7311.0	46.0	32.9	45.9	32.9	54.0
9748.0	46.1	33.7	45.8	33.2	54.0
12185.0	48.3	35.8	48.3	35.9	54.0
14622.0	49.9	36.7	49.1	36.7	54.0
17059.0	53.2	40.7	53.6	40.7	54.0
2462.0	--	--	--	--	--
4924.0	45.0	31.7	44.8	31.9	54.0
7386.0	45.3	32.9	46.1	33.3	54.0
9848.0	47.3	34.3	46.9	34.3	54.0
12310.0	48.5	35.8	48.5	35.5	54.0
14772.0	50.8	37.5	50.5	37.6	54.0
17234.0	53.5	40.7	53.5	40.4	54.0

Other emissions present had amplitudes at least 20 dB below the limit. Peak and Quasi-Peak amplitude emissions are recorded for frequency below 1000 MHz. Peak and Average amplitude emissions are recorded for frequency range above 1000 MHz.

**Table 4 Transmitter Antenna Port Data**

Frequency MHz	Antenna Port Output Power Peak / Ave. (Watts)	99% Occupied Bandwidth (kHz)	6-dB Occupied Bandwidth (kHz)	Peak Power Spectral Density (dBm)
802.11b				
2412	0.076 / 0.039	13470.0	8415.0	4.98
2437	0.094 / 0.052	13590.0	8235.0	5.99
2462	0.079 / 0.042	13530.0	8145.0	5.34
802.11g				
2412	0.136 / 0.012	16880.0	16120.0	2.45
2437	0.269 / 0.045	17240.0	16080.0	7.28
2462	0.170 / 0.015	17000.0	16000.0	2.42
802.11n				
2412	0.127 / 0.013	17960.0	17120.0	2.43
2437	0.280 / 0.49	18280.0	17520.0	7.35
2462	0.185 / 0.014	18000.0	17400.0	2.43

**Summary of Results for Transmitter Radiated Emissions of Intentional Radiator**

The EUT demonstrated compliance with the radiated emissions requirements of CFR47 Part 15.247, RSS-GEN, and RSS-247 Digital Transmission Systems. Antenna port conducted output power of 0.052 Watts average and 0.28 Watts peak was measured at the temporary antenna port of the EUT. The peak power spectral density measured at the antenna port presented a minimum margin of -0.65 dB below the requirements. The EUT demonstrated a minimum margin of -13.3 dB below the harmonic emissions requirements. There were no other significantly measurable emissions in the restricted bands other than those recorded in this report. Other emissions were present with amplitudes at least 20 dB below the requirements. There were no other deviations or exceptions to the requirements.

## Annex

- Annex A Measurement Uncertainty Calculations
- Annex B Rogers Labs Test Equipment List
- Annex C Rogers Qualifications
- Annex D Rogers Labs Certificate of Accreditation

## Annex A Measurement Uncertainty Calculations

Measurement uncertainty calculations were made for the laboratory. Result of measurement uncertainty calculations are recorded below for AC line conducted and radiated emission measurements.

Measurement Uncertainty	$U_{(E)}$	$U_{(lab)}$
3 Meter Horizontal 30-200 MHz Measurements	2.08	4.16
3 Meter Vertical 30-200 MHz Measurements	2.16	4.33
3 Meter Vertical Measurements 200-1000 MHz	2.99	5.97
10 Meter Horizontal Measurements 30-200 MHz	2.07	4.15
10 Meter Vertical Measurements 30-200 MHz	2.06	4.13
10 Meter Horizontal Measurements 200-1000 MHz	2.32	4.64
10 Meter Vertical Measurements 200-1000 MHz	2.33	4.66
3 Meter Measurements 1-6 GHz	2.57	5.14
3 Meter Measurements 6-18 GHz	2.58	5.16
AC Line Conducted	1.72	3.43

## Annex B Rogers Labs Test Equipment List

List of Test Equipment	Calibration	Date	Due
Spectrum Analyzer: Rohde & Schwarz ESU40		5/17	5/18
Spectrum Analyzer: HP 8562A, HP Adapters: 11518, 11519, and 11520		5/17	5/18
Mixers: 11517A, 11970A, 11970K, 11970U, 11970V, 11970W			
Spectrum Analyzer: HP 8591EM		5/17	5/18
Antenna: EMCO Biconilog Model: 3143		5/17	5/18
Antenna: Sunol Biconilog Model: JB6		10/16	10/17
Antenna: EMCO Log Periodic Model: 3147		10/16	10/17
Antenna: Com Power Model: AH-118		10/16	10/17
Antenna: Com Power Model: AH-840		5/17	5/18
Antenna: Antenna Research Biconical Model: BCD 235		10/16	10/17
Antenna: Com Power Model: AL-130		10/16	10/17
Antenna: EMCO 6509		10/16	10/17
LISN: Compliance Design Model: FCC-LISN-2.Mod.cd, 50 µHy/50 ohms/0.1 µf		10/16	10/17
R.F. Preamp CPPA-102		10/16	10/17
Attenuator: HP Model: HP11509A		10/16	10/17
Attenuator: Mini Circuits Model: CAT-3		10/16	10/17
Attenuator: Mini Circuits Model: CAT-3		10/16	10/17
Cable: Belden RG-58 (L1)		10/16	10/17
Cable: Belden RG-58 (L2)		10/16	10/17
Cable: Belden 8268 (L3)		10/16	10/17
Cable: Time Microwave: 4M-750HF290-750		10/16	10/17
Cable: Time Microwave: 10M-750HF290-750		10/16	10/17
Frequency Counter: Leader LDC825		2/17	2/18
Oscilloscope Scope: Tektronix 2230		2/17	2/18
Wattmeter: Bird 43 with Load Bird 8085		2/17	2/18
Power Supplies: Sorensen SRL 20-25, SRL 40-25, DCR 150, DCR 140		2/17	2/18
R.F. Generators: HP 606A, HP 8614A, HP 8640B		2/17	2/18
R.F. Power Amp 65W Model: 470-A-1010		2/17	2/18
R.F. Power Amp 50W M185- 10-501		2/17	2/18
R.F. Power Amp A.R. Model: 10W 1010M7		2/17	2/18
R.F. Power Amp EIN Model: A301		2/17	2/18
LISN: Compliance Eng. Model 240/20		2/17	2/18
LISN: Fischer Custom Communications Model: FCC-LISN-50-16-2-08		2/17	2/18
Antenna: EMCO Dipole Set 3121C		2/17	2/18
Antenna: C.D. B-101		2/17	2/18
Antenna: Solar 9229-1 & 9230-1		2/17	2/18
Audio Oscillator: H.P. 201CD		2/17	2/18
ESD Test Set 2010i		2/17	2/18
Fast Transient Burst Generator Model: EFT/B-101		2/17	2/18
Field Intensity Meter: EFM-018		2/17	2/18
KEYTEK Ecat Surge Generator		2/17	2/18
Shielded Room 5 M x 3 M x 3.0 M			

## **Annex C Rogers Qualifications**

***Scot D. Rogers, Engineer***

### **Rogers Labs, Inc.**

Mr. Rogers has approximately 17 years' experience in the field of electronics. Engineering experience includes six years in the automated controls industry and remaining years working with the design, development and testing of radio communications and electronic equipment.

#### Positions Held

Systems Engineer: A/C Controls Mfg. Co., Inc. 6 Years

Electrical Engineer: Rogers Consulting Labs, Inc. 5 Years

Electrical Engineer: Rogers Labs, Inc. Current

#### Educational Background

- 1) Bachelor of Science Degree in Electrical Engineering from Kansas State University.
- 2) Bachelor of Science Degree in Business Administration Kansas State University.
- 3) Several Specialized Training courses and seminars pertaining to Microprocessors and Software programming.

*Scot D. Rogers*

Scot D. Rogers



## Annex D Rogers Labs Certificate of Accreditation

<p>United States Department of Commerce National Institute of Standards and Technology</p>  <hr/> <p><b>Certificate of Accreditation to ISO/IEC 17025:2005</b></p> <hr/> <p>NVLAP LAB CODE: 200087-0</p> <p><b>Rogers Labs, Inc.</b> Louisburg, KS</p> <p><i>is accredited by the National Voluntary Laboratory Accreditation Program for specific services, listed on the Scope of Accreditation, for:</i></p> <p><b>Electromagnetic Compatibility &amp; Telecommunications</b></p> <p><i>This laboratory is accredited in accordance with the recognized International Standard ISO/IEC 17025:2005. This accreditation demonstrates technical competence for a defined scope and the operation of a laboratory quality management system (refer to joint ISO-ILAC-IAF Communiqué dated January 2009).</i></p> <hr/> <table border="0" style="width: 100%;"><tr><td style="width: 40%; text-align: center;"><p>2017-03-01 through 2018-03-31 <i>Effective Dates</i></p></td><td style="width: 20%; text-align: center;"></td><td style="width: 40%; text-align: center;"> <i>For the National Voluntary Laboratory Accreditation Program</i></td></tr></table>		<p>2017-03-01 through 2018-03-31 <i>Effective Dates</i></p>		 <i>For the National Voluntary Laboratory Accreditation Program</i>
<p>2017-03-01 through 2018-03-31 <i>Effective Dates</i></p>		 <i>For the National Voluntary Laboratory Accreditation Program</i>		

Rogers Labs, Inc.  
4405 West 259th Terrace  
Louisburg, KS 66053  
Phone/Fax: (913) 837-3214  
Revision 2

Garmin International, Inc.    SN's: CE/FCC unit1, CE/FCC unit2  
Models: A03198 and B03198    FCC ID: IPH-03198  
Test #: 170817  
Test to: CFR47 15C, RSS-Gen RSS-247  
File: A03198 DTS TstRpt 170817 r2

IC: 1792A-03198  
Date: October 27, 2017  
Page 33 of 33