

Application For Grant of Certification

FOR

FOR

Model: M3BPGT00

2402-2480 MHz

Low Power Transmitter

FCC ID: IPH-02117

IC: 1792A-02117

FOR

Garmin International, Inc.

1200 East 151st Street

Olathe, KS 66062

Test Report Number: 130408

Authorized Signatory: *Scot D. Rogers*

Scot D. Rogers

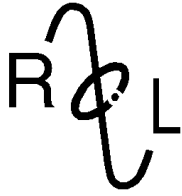

ROGERS LABS, INC.

4405 West 259th Terrace
 Louisburg, KS 66053
 Phone / Fax (913) 837-3214

**Engineering Test Report For
 Grant of Certification Application**

FOR
 CFR 47, PART 15C - Intentional Radiators
 CFR 47 Paragraph 15.249 and Industry Canada RSS-210
 License Exempt Intentional Radiator

For

Garmin International, Inc.

1200 East 151st Street
 Olathe, KS 66062

Model: M3BPGT00

Low Power Transmitter

Frequency Range 2402-2480 MHz
 FCC ID#: IPH-02117
 IC: 1792A-02117

Test Date: April 8, 2013

Certifying Engineer: *Scot D. Rogers*
 Scot D. Rogers
 Rogers Labs, Inc.
 4405 West 259th Terrace
 Louisburg, KS 66053
 Telephone/Facsimile: (913) 837-3214

This report shall not be reproduced except in full, without the written approval of the laboratory.
 This report must not be used by the client to claim product certification, approval or endorsement
 by NVLAP, NIST, or any agency of the Federal Government.



Table Of Contents

TABLE OF CONTENTS..... 3

REVISIONS..... 4

FORWARD 5

OPINION / INTERPRETATION OF RESULTS 5

EQUIPMENT TESTED..... 5

EQUIPMENT FUNCTION AND CONFIGURATION..... 6

 Equipment Configuration.....7

APPLICATION FOR CERTIFICATION..... 9

APPLICABLE STANDARDS & TEST PROCEDURES 10

EQUIPMENT TESTING PROCEDURES 10

AC Line Conducted Emission Test Procedure10

 Diagram 1 Test arrangement for Conducted emissions11

Radiated Emission Test Procedure.....12

 Diagram 2 Test arrangement for radiated emissions of tabletop equipment.....12

 Diagram 3 Test arrangement for radiated emissions tested on Open Area Test Site (OATS).....13

TEST SITE LOCATIONS 14

UNITS OF MEASUREMENTS 14

ENVIRONMENTAL CONDITIONS..... 14

LIST OF TEST EQUIPMENT 15

INTENTIONAL RADIATORS..... 16

Antenna Requirements16

Restricted Bands of Operation.....16

 Table 1 General Radiated Emissions in Restricted Bands Data16

 Table 2 Harmonic Radiated Emissions in Restricted Bands Data17

Summary of Results for Radiated Emissions in Restricted Bands17

General Radiated Emissions Procedure.....18



Table 3 General Radiated Emissions from EUT Data (Highest Emissions)19

Summary of Results for General Radiated Emissions19

Operation in the Band 2400 – 2483.5 MHz20

Figure 1 Plot of Transmitter Emissions (Output in Operational Band)21

Figure 2 Plot of Transmitter Emissions (Occupied Bandwidth)21

Figure 3 Plot of Transmitter Emissions (Low Band Edge)22

Figure 4 Plot of Low Band Edge (High Band Edge)22

Transmitter Emissions Data.....23

Table 4 Transmitter Radiated Emissions23

Summary of Results for Transmitter Radiated Emissions of Intentional Radiator24

STATEMENT OF MODIFICATIONS AND DEVIATIONS 24

ANNEX..... 25

Annex A Measurement Uncertainty Calculations26

Annex B Rogers Labs Test Equipment List.....27

Annex C Rogers Qualifications28

Annex D FCC Site Registration Letter.....29

Annex E Industry Canada Site Registration Letter30

Revisions

Revision 1 Issued May 15, 2013



Forward

The following information is submitted for consideration in obtaining Grant of Certification for low power intentional radiator per CFR 47 Paragraph 15.249, and Industry Canada RSS-210, operation in the 2400 – 2483.5 MHz band.

Name of Applicant: Garmin International, Inc.
1200 East 151st Street
Olathe, KS 66062

Model: M3BPGT00

FCC I.D.: IPH-02117 Industry Canada ID: 1792A-02117

Frequency Range: 2402-2480 MHz

Operating power: maximum average power 48.6 dBμV/m @ 3 meters (and peak 101.1 dBμV/m @ 3 meters), 6-dB occupied bandwidth 437.5 kHz

Opinion / Interpretation of Results

Tests Performed	Margin (dB)	Results
Emissions as per CFR 47 paragraphs 2 and 15.205	-2.7	Complies
Emissions as per CFR 47 paragraphs 2 and 15.207	N/A	Complies
Emissions as per CFR 47 paragraphs 2 and 15.209	-5.8	Complies
Harmonic Emissions per CFR 47 15.249	-8.0	Complies

Equipment Tested

<u>Equipment</u>	<u>Model / PN</u>	<u>Serial Number</u>
EUT	M3BPGT00	3860566770
EUT (#2)	M3BPGT00	3860566748
Support Interface	As supplied by Manufacturer	N/A
DC Power supply	1670A	N961313540

Test results in this report relate only to the items tested.



Equipment Function and Configuration

The EUT is a GPS mapping display and interface system providing interface options as presented in configuration diagrams. The circuitry is provided in alternate configurations offering reduced functionality. Preliminary testing was performed and final emissions testing performed on worst-case configuration. The completed system offers end user ability to utilize GPS information for display of location and navigational aid. The EUT incorporates a low power transmitter with operation capability in the 2402-2480 MHz frequency band (CFR 47 15.249 and RSS-210). The design utilizes internal fixed antenna system and offers no provision for antenna replacement or modification. Two samples were provided for testing, one production design and the other modified for testing purposes replacing integral antenna with RF connection port. Both samples were provided with test software enabling testing personnel ability to enable transmitter function on defined channels. The antenna modification offered testing facility ability to connect transmitter antenna port to test equipment for antenna port conducted emissions testing. The EUT was arranged as typical user equipment configurations for testing purposes. The transmitter offers no other interface connections than those in the configuration diagrams shown below. The unit operates from power received from the supporting equipment and system. For testing purposes, the EUT received powered from external DC supply powering supporting equipment and was configured to transmit in available data modes. As requested by the manufacturer and required by regulations, the equipment was tested for emissions compliance using the available configurations with the worst-case data presented. Test results in this report relate only to the products described in this report.

Equipment Configuration

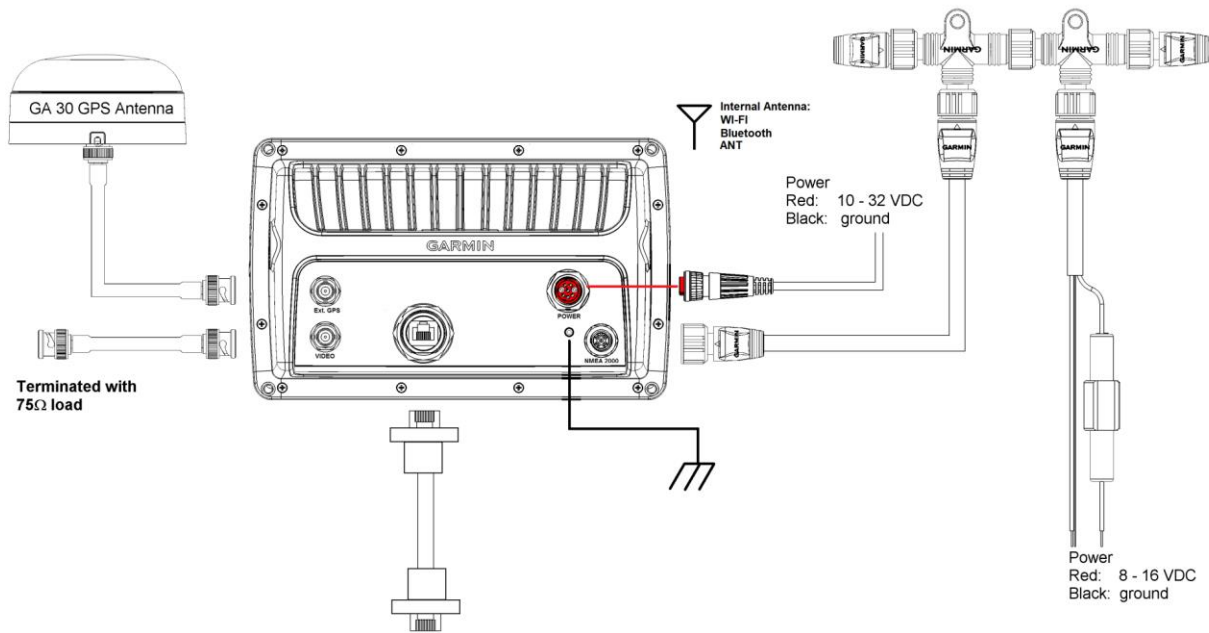
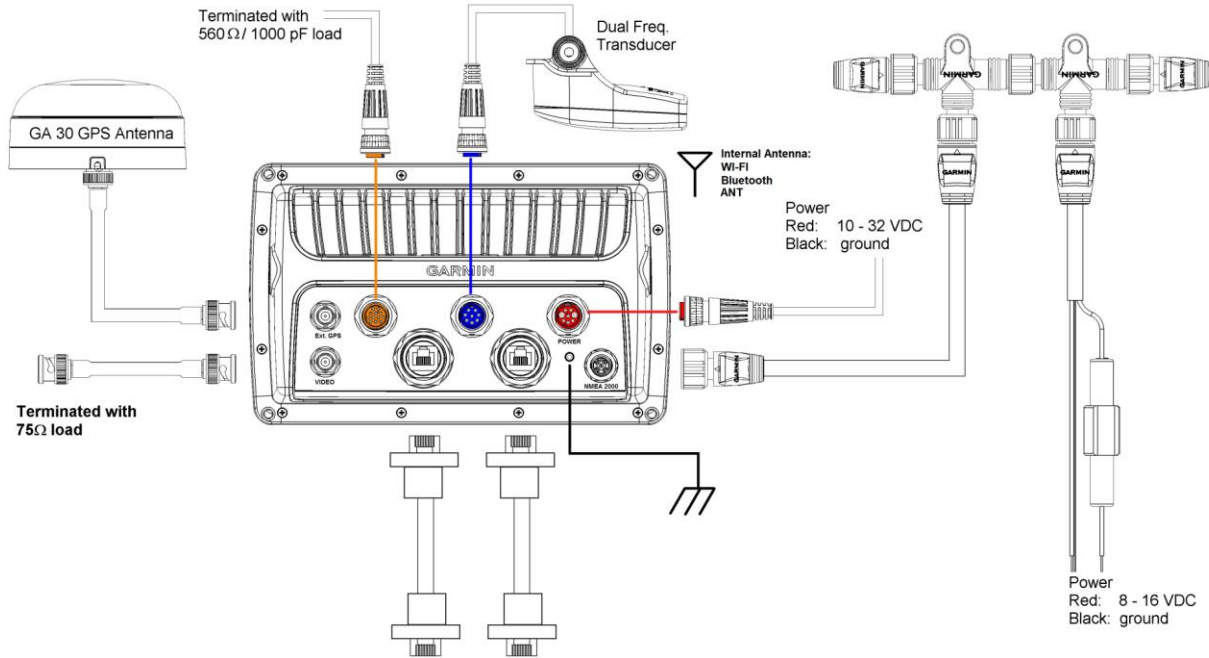

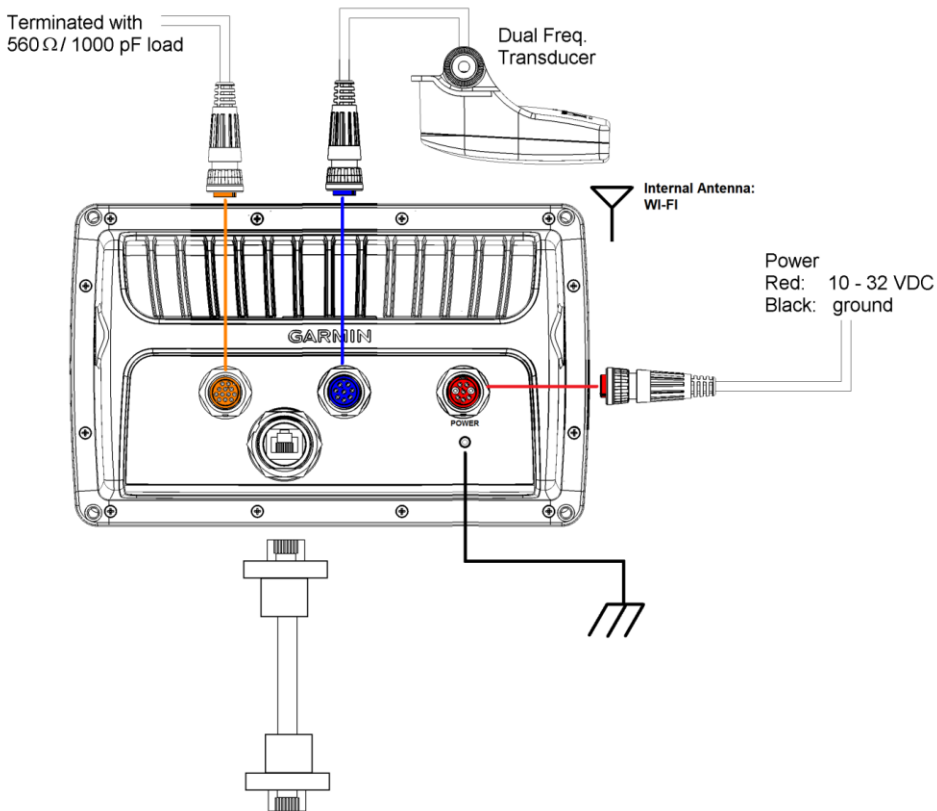
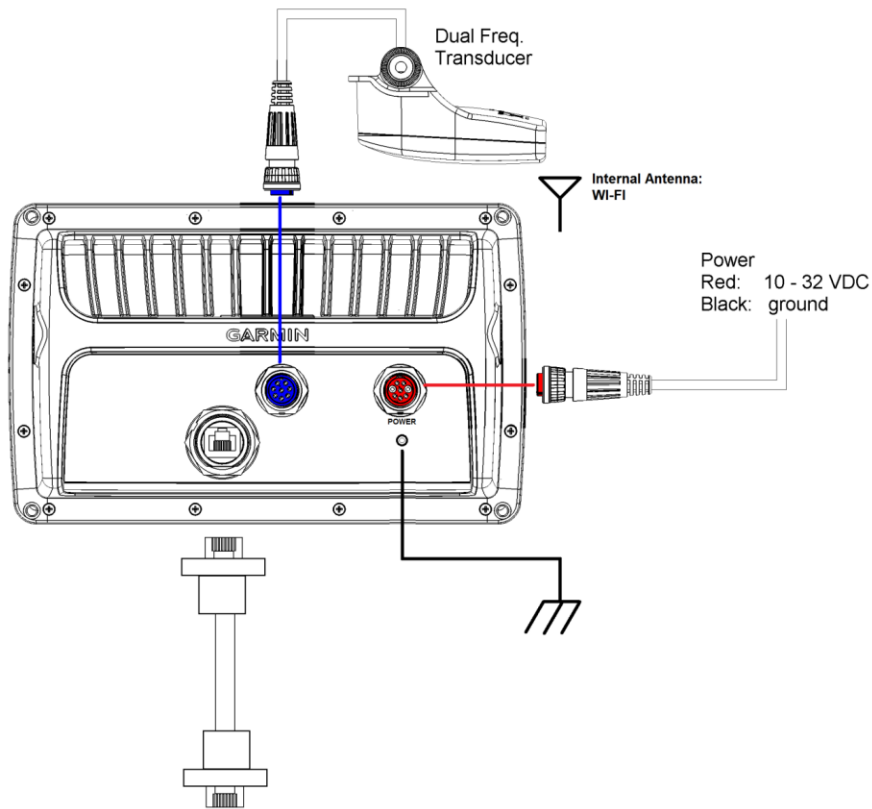



Application for Certification

- (1) Manufacturer: Garmin International, Inc.
1200 East 151st Street
Olathe, KS 66062
- (2) Identification: Model: M3BPGT00
FCC I.D.: IPH-02117 IC ID: 1792A-02117
- (3) Instruction Book:
Refer to Exhibit for Instruction Manual.
- (4) Description of Circuit Functions:
Refer to Exhibit of Operational Description.
- (5) Block Diagram with Frequencies:
Refer to Exhibit of Operational Description.
- (6) Report of Measurements:
Report of measurements follows in this Report.
- (7) Photographs: Construction, Component Placement, etc.:
Refer to Exhibit for photographs of equipment.
- (8) List of Peripheral Equipment Necessary for operation. The equipment operates from DC power supplied from supporting equipment and installation vehicle only. The EUT offers no other connection ports than those presented in this filing.
- (9) Transition Provisions of CFR47 15.37 are not requested.
- (10) Not Applicable. The unit is not a scanning receiver.
- (11) Not Applicable. The EUT does not operate in the 59 – 64 GHz frequency band.
- (12) The equipment is not software defined and this section is not applicable.

Applicable Standards & Test Procedures

In accordance with the Federal Communications Code of Federal Regulations, dated October 1, 2012, Part 2, Subpart J, Paragraphs 2.907, 2.911, 2.913, 2.925, 2.926, 2.1031 through 2.1057, and applicable parts of paragraph 15, Part 15C Paragraph 15.249, and RSS-210 the following information is submitted. Test procedures used are the established Methods of Measurement of Radio-Noise Emissions as described in ANSI C63.4-2009 and ANSI C63.10-2009. Testing for the AC line-conducted emissions were performed as defined in sections 7 and 13.1.3, testing of the radiated emissions was performed as defined in sections 8 and 13.1.4 of ANSI C63.4-2009. Testing of the radiated emissions was performed as required including procedures in section 13 of ANSI C63.4-2009.

Equipment Testing Procedures

AC Line Conducted Emission Test Procedure

The EUT operates solely from direct current power and offers no provision for connection to utility AC power systems. Therefore, no AC power line conducted emissions test was required or performed. If required, the manufacturer supplied AC connection would be used to power the EUT. Testing for the AC line-conducted emissions testing would be performed as defined in sections 7 and 13.1.3 of ANSI C63.4-2009. The test setup including the EUT would be arranged in typical equipment configurations and placed on a 1 x 1.5-meter wooden bench, 0.8 meters high located in a screen room. The power lines of the system would be isolated from the power source using a standard LISN with a 50- μ Hy choke. EMI was coupled to the spectrum analyzer through a 0.1 μ F capacitor internal to the LISN. The LISN would be positioned on the floor beneath the wooden bench supporting the EUT. The power lines and cables would be draped over the back edge of the table. Refer to diagram 1 showing typical test arrangement and photographs in the test setup exhibits for specific EUT placement during testing.

Diagram 1 Test arrangement for Conducted emissions

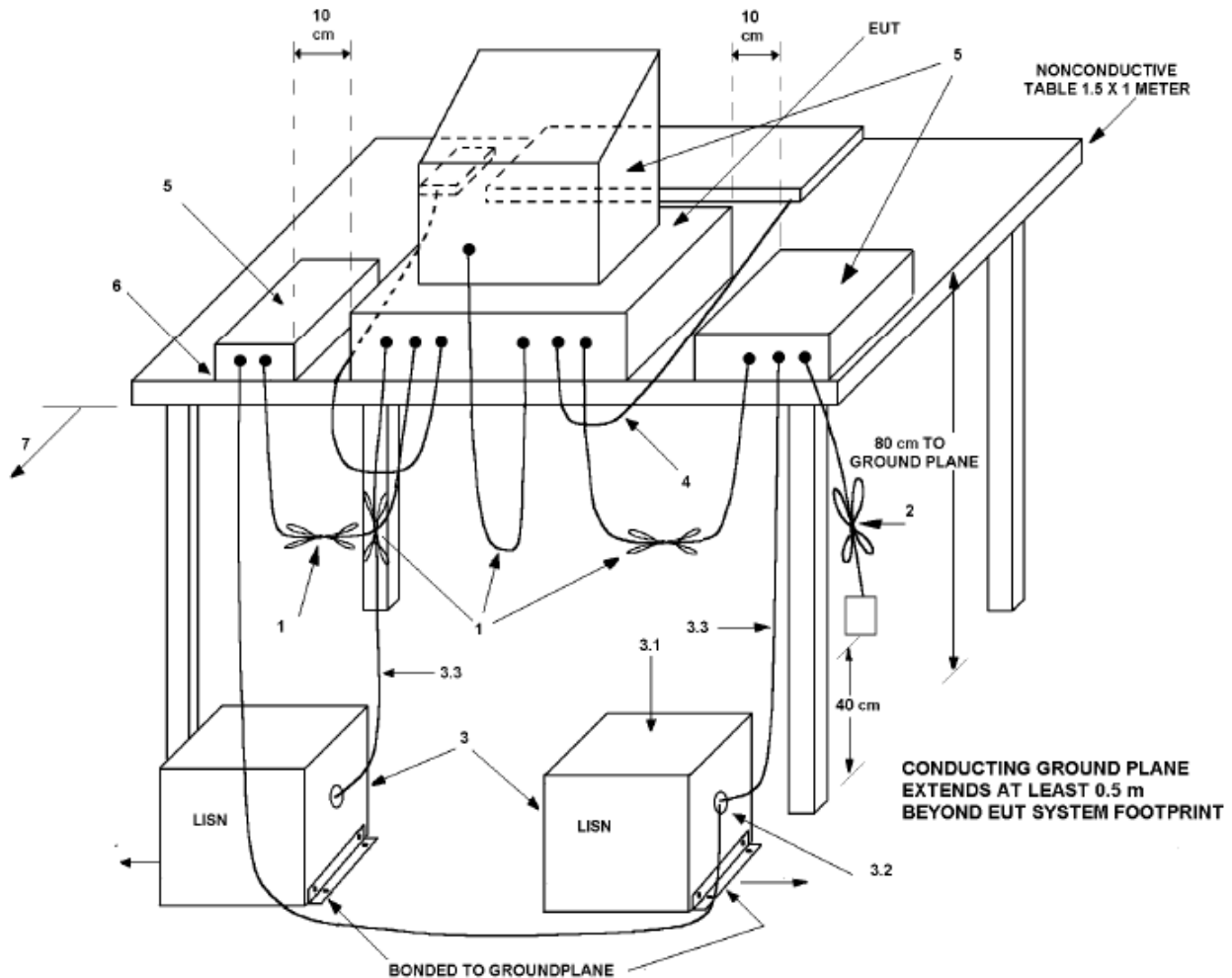

1. Interconnecting cables that hang closer than 40 cm to the ground plane were folded back and forth in the center forming a bundle 30 cm to 40 cm long.
2. Input/output (I/O) cables that are not connected to a peripheral shall be bundled in the center. The end of the cable may be terminated, if required, using the correct terminating impedance. The overall length shall not exceed 1 m.
3. EUT connected to one LISN. Unused LISN measuring port connectors are terminated into 50 Ω loads. LISN is placed on top of and bonded to reference ground plane.
 - 3.1 All other equipment powered from additional LISN(s).
 - 3.2 Multiple outlet strips can be used for multiple power cords of non-EUT equipment.
 - 3.3 LISN is positioned at least 80 cm from nearest part of EUT chassis.
4. Cables of hand-operated devices, such as keyboards, mice, and so on, shall be placed as for normal use.
5. Non-EUT components of EUT system being tested.
6. Rear of EUT, including peripherals, shall all be aligned and flush with rear of tabletop.
7. Rear of tabletop shall be 40 cm removed from a vertical conducting plane that is bonded to the ground plane (see 5.2.2 for options).

Radiated Emission Test Procedure

The EUT was placed on a rotating 1 x 1.5-meter wooden platform, 0.8 meters above the ground plane at a distance of 3 meters from the FSM antenna. Radiated emissions testing was performed as required in CFR47 15, RSS-210 and specified in sections 8 and 13.1.4 of ANSI C63.4-2009. EMI energy was maximized by equipment placement, raising and lowering the FSM antenna, changing the antenna polarization, and by rotating the turntable. Each emission was maximized before data was taken using a spectrum analyzer. The frequency spectrum from 9 kHz to 25,000 MHz was searched for during preliminary investigation. Refer to diagrams 2 and 3 showing typical test arrangement and photographs in the test setup exhibits for specific EUT placement during testing.

Diagram 2 Test arrangement for radiated emissions of tabletop equipment

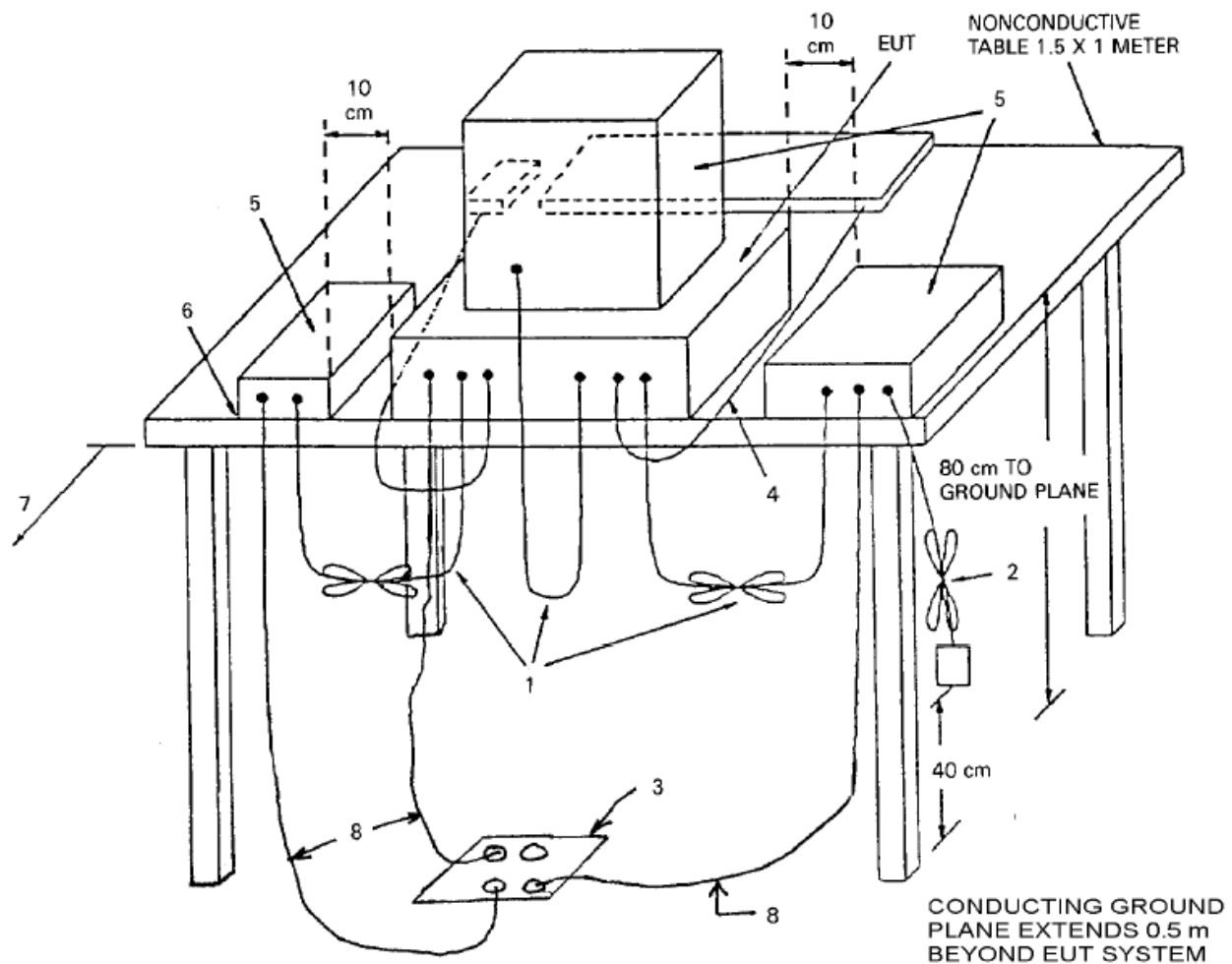

1. Interconnecting cables that hang closer than 40 cm to the ground plane shall be folded back and forth in the center, forming a bundle 30 cm to 40 cm long.

2. I/O cables that are not connected to a peripheral shall be bundled in the center. The end of the cable may be terminated if required using the correct terminating impedance. The total length shall not exceed 1 m.
3. If LISNs are kept in the test setup for radiated emissions, it is preferred that they be installed under the ground plane with the receptacle flush with the ground plane.
4. Cables of hand-operated devices, such as keyboards, mice, and so on, shall be placed as for normal use.
5. Non-EUT components of EUT system being tested.
6. Rear of EUT, including peripherals, shall all be aligned and flush with rear of tabletop (possibly center of table for transmitter equipment).
7. No vertical conducting plane used.
8. Power cords drape to the floor and are routed over to receptacle.

Diagram 3 Test arrangement for radiated emissions tested on Open Area Test Site (OATS)

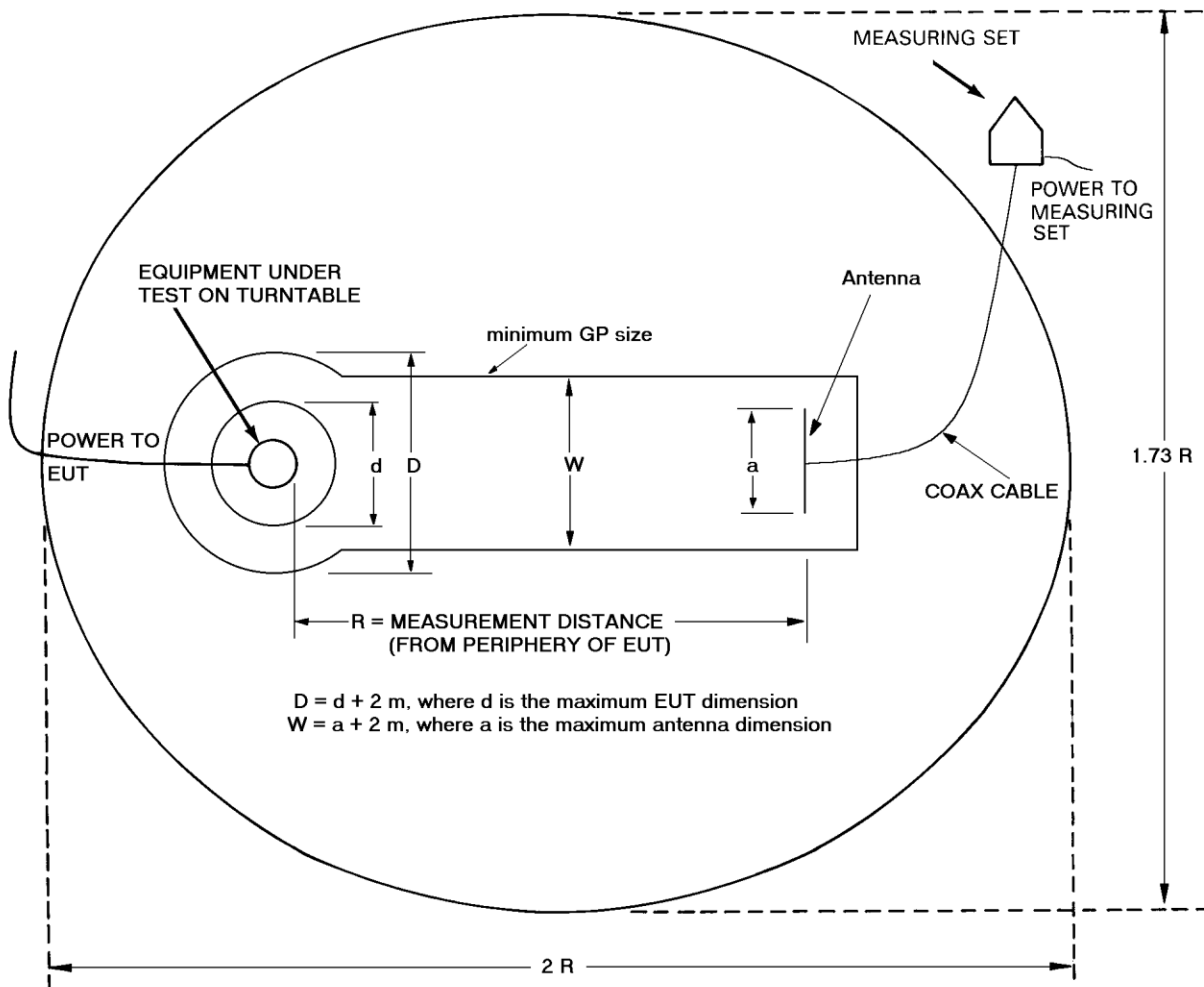

AREA DIMENSIONS =	R = 3m	R = 10 m	R = 30 m
	6 m x 5.2 m	20 m x 17.3 m	60 m x 52 m



Test Site Locations

Conducted EMI	The AC power line conducted emissions testing performed in a shielded screen room located at Rogers Labs, Inc., 4405 W. 259 th Terrace, Louisburg, KS
Radiated EMI	The radiated emissions tests were performed at the 3 meters, Open Area Test Site (OATS) located at Rogers Labs, Inc., 4405 W. 259 th Terrace, Louisburg, KS
Site Registration	Refer to Annex for Site Registration Letters
NVLAP Accreditation	Lab code 200087-0

Units of Measurements

Conducted EMI	Data is in dB μ V; dB referenced to one microvolt
Radiated EMI	Data is in dB μ V/m; dB/m referenced to one microvolt per meter

Sample Calculation:

RFS = Radiated Field Strength, FSM = Field Strength Measured
A.F. = Receive antenna factor, Gain = amplification gains and/or cable losses
 $RFS (dB\mu V/m @ 3m) = FSM (dB\mu V) + A.F. (dB) - Gain (dB)$

Environmental Conditions

Ambient Temperature	22.5° C
Relative Humidity	42%
Atmospheric Pressure	1004.2 mb

List of Test Equipment

A Rohde and Schwarz ESU40 and/or Hewlett Packard 8591EM was used as the measuring device for the emissions testing of frequencies below 1 GHz. A Rohde and Schwarz ESU40 and/or Hewlett Packard 8562A Spectrum Analyzer was used as the measuring device for testing the emissions at frequencies above 1 GHz. The analyzer settings used are described in the following table. Refer to the appendix for a complete list of test equipment.

AC Line Conducted Emissions (0.150 -30 MHz)		
RBW	AVG. BW	Detector Function
9 kHz	30 kHz	Peak / Quasi Peak
Emissions (30-1000 MHz)		
RBW	AVG. BW	Detector Function
120 kHz	300 kHz	Peak / Quasi Peak
Emissions (Above 1000 MHz)		
RBW	Video BW	Detector Function
100 kHz	100 kHz	Peak
1 MHz	1 MHz	Peak / Average

<u>Equipment</u>	<u>Manufacturer</u>	<u>Model</u>	<u>Band</u>	<u>Cal Date</u>	<u>Due</u>
<input type="checkbox"/> LISN	Comp. Design	FCC-LISN-2-MOD.CD	.15-30MHz	10/12	10/13
<input type="checkbox"/> Antenna	ARA	BCD-235-B	20-350MHz	10/12	10/13
<input type="checkbox"/> Antenna	EMCO	3147	200-1000MHz	10/12	10/13
<input checked="" type="checkbox"/> Antenna	Com Power	AH-118	1-18 GHz	10/12	10/13
<input checked="" type="checkbox"/> Antenna	Com Power	AH-840	18-40 GHz	10/12	10/13
<input checked="" type="checkbox"/> Antenna	EMCO	6509	.001-30 MHz	10/12	10/13
<input checked="" type="checkbox"/> Antenna	Sunol	JB-6	30-1000 MHz	10/12	10/13
<input checked="" type="checkbox"/> Antenna	Standard	FXRY638A	10-18 GHz	3/12	5/13
<input type="checkbox"/> Antenna	EMCO	3143	20-1200 MHz	5/12	5/13
<input type="checkbox"/> Analyzer	HP	8591EM	9kHz-1.8GHz	5/12	5/13
<input type="checkbox"/> Analyzer	HP	8562A	9kHz-110GHz	5/12	5/13
<input checked="" type="checkbox"/> Analyzer	Rohde & Schwarz	ESU40	20Hz-40GHz	5/12	5/13
<input checked="" type="checkbox"/> Amplifier	Com-Power	PA-010	100Hz-30MHz	10/12	10/13
<input checked="" type="checkbox"/> Amplifier	Com-Power	CPPA-102	1-1000 MHz	10/12	10/13
<input checked="" type="checkbox"/> Amplifier	Com-Power	PA-22	0.5-22 GHz	10/12	10/13



Intentional Radiators

As per CFR47, Subpart C, paragraph 15.249 and RSS-210 the following information is submitted.

Antenna Requirements

The EUT incorporates integral antenna system and offers no provision for connection to alternate system. The antenna connection point complies with the unique antenna connection requirements. The unique antenna connection requirements are fulfilled. There are no deviations or exceptions to the specification.

Restricted Bands of Operation

Spurious emissions falling in the restricted frequency bands of operation were measured at the OATS. The EUT utilizes frequency, determining circuitry, which generates harmonics falling in the restricted bands. Emissions were investigated at the OATS, using appropriate antennas or pyramidal horns, amplification stages, and a spectrum analyzer. Peak and average amplitudes of frequencies above 1000 MHz were compared to the required limits with worst-case data presented below. Test procedures of ANSI C63.4-2009 paragraphs 13.1 and 8.3.1.2 were used during testing. No other significant emission was observed which fell into the restricted bands of operation. Computed emission values take into account the received radiated field strength, receive antenna correction factor, amplifier gain stage, and test system cable losses.

Table 1 General Radiated Emissions in Restricted Bands Data

Frequency in MHz	Horizontal Peak (dBμV/m)	Horizontal Quasi-Peak (dBμV/m)	Horizontal Average (dBμV/m)	Vertical Peak (dBμV/m)	Vertical Quasi-Peak (dBμV/m)	Vertical Average (dBμV/m)	Limit @ 3m (dBμV/m)
108.0	41.1	38.2	N/A	35.9	34.2	N/A	43.5
111.0	31.3	23.8	N/A	27.3	23.7	N/A	43.5
112.5	32.6	25.2	N/A	27.3	23.1	N/A	43.5
119.4	28.1	22.4	N/A	21.9	16.4	N/A	43.5
120.6	32.1	23.8	N/A	27.1	17.7	N/A	43.5
121.6	36.2	26.2	N/A	24.8	18.5	N/A	43.5
123.5	31.1	20.5	N/A	22.2	15.5	N/A	43.5
126.0	42.4	40.8	N/A	36.8	34.4	N/A	43.5
129.9	31.5	24.0	N/A	27.0	18.6	N/A	43.5

Table 2 Harmonic Radiated Emissions in Restricted Bands Data

Frequency in MHz	Horizontal Peak (dBµV/m)	Horizontal Quasi-Peak (dBµV/m)	Horizontal Average (dBµV/m)	Vertical Peak (dBµV/m)	Vertical Quasi-Peak (dBµV/m)	Vertical Average (dBµV/m)	Limit @ 3m (dBµV/m)
2390.0	42.2	N/A	29.4	41.9	N/A	29.5	54.0
2483.5	48.2	N/A	31.4	46.6	N/A	31.4	54.0
4804.0	47.6	N/A	35.2	48.2	N/A	35.3	54.0
4914.0	47.6	N/A	34.5	47.7	N/A	34.5	54.0
4960.0	47.8	N/A	35.0	45.0	N/A	32.2	54.0
7206.0	49.2	N/A	36.5	49.1	N/A	36.5	54.0
7371.0	50.3	N/A	36.9	49.5	N/A	37.0	54.0
7440.0	50.8	N/A	37.5	49.1	N/A	36.7	54.0
12010.0	49.1	N/A	36.2	49.1	N/A	36.4	54.0
12285.0	49.1	N/A	36.4	50.5	N/A	37.3	54.0
12400.0	50.1	N/A	37.7	49.6	N/A	37.4	54.0

Other emissions present had amplitudes at least 20 dB below the limit. Peak and Quasi-Peak amplitude emissions are recorded for frequency range below 1000 MHz. Peak and Average amplitude emissions are recorded for frequency range above 1000 MHz.

Summary of Results for Radiated Emissions in Restricted Bands

The EUT demonstrated compliance with the radiated emissions requirements of CFR 47 Part 15C and RSS-210 Intentional Radiators. The EUT demonstrated a worst-case minimum margin of -2.7 dB below the radiated emissions requirements in restricted frequency bands. Peak, Quasi-peak, and average amplitudes were checked for compliance with the regulations. Worst-case emissions are reported with other emissions found in the restricted frequency bands at least 20 dB below the requirements.



General Radiated Emissions Procedure

The EUT was arranged in a typical equipment configuration and operated through all available modes with worst-case data recorded. Preliminary testing was performed in a screen room with the EUT positioned 1 meter from the FSM. Radiated emissions measurements were performed to identify the frequencies, which produced the highest emissions. Each radiated emission was then maximized at the OATS location before final radiated emissions measurements were performed. Final data was taken with the EUT located at the OATS at a distance of 3 meters between the EUT and the receiving antenna. The frequency spectrum from 9 kHz to 25,000 MHz was searched for general radiated emissions. Measured emission levels were maximized by EUT placement on the table, rotating the turntable through 360 degrees, varying the antenna height between 1 and 4 meters above the ground plane and changing antenna position between horizontal and vertical polarization. Antennas used were Loop from 9 kHz to 30 MHz, Broadband Biconical from 30 to 200 MHz, Biconilog from 30 to 1000 MHz, Log Periodic from 200 MHz to 1 GHz and or double Ridge or pyramidal horns and mixers from 1 GHz to 40 GHz, notch filters and appropriate amplifiers and external mixers were utilized.

Table 3 General Radiated Emissions from EUT Data (Highest Emissions)

Frequency in MHz	Horizontal Peak (dBµV/m)	Horizontal Quasi-Peak (dBµV/m)	Horizontal Average (dBµV/m)	Vertical Peak (dBµV/m)	Vertical Quasi-Peak (dBµV/m)	Vertical Average (dBµV/m)	Limit @ 3m (dBµV/m)
59.2	34.1	22.5	N/A	32.4	29.1	N/A	40.0
59.9	28.1	26.1	N/A	34.1	27.7	N/A	40.0
61.0	46.8	34.2	N/A	46.3	33.4	N/A	40.0
61.4	42.7	33.1	N/A	30.8	26.8	N/A	40.0
61.5	26.7	21.2	N/A	37.3	26.7	N/A	40.0
144.0	36.1	34.0	N/A	35.4	30.2	N/A	43.5
146.4	30.0	20.7	N/A	20.7	16.5	N/A	43.5
146.8	25.3	19.9	N/A	21.4	16.5	N/A	43.5
146.9	27.9	23.5	N/A	21.4	16.7	N/A	43.5
147.8	31.5	23.0	N/A	23.0	18.0	N/A	43.5
252.0	38.7	37.6	N/A	32.7	30.7	N/A	46.0
288.0	42.7	36.6	N/A	35.4	29.6	N/A	46.0
338.0	29.3	24.6	N/A	19.5	14.4	N/A	46.0
360.0	39.0	30.9	N/A	37.3	36.3	N/A	46.0
396.0	38.2	35.5	N/A	36.9	34.2	N/A	46.0

Other emissions present had amplitudes at least 20 dB below the limit. Peak and Quasi-Peak amplitude emissions are recorded for frequency range below 1000 MHz. Peak and Average amplitude emissions are recorded for frequency range above 1000 MHz.

Summary of Results for General Radiated Emissions

The EUT demonstrated compliance with the radiated emissions requirements of CFR47 Part 15C paragraph 15.209 and RSS-210 Intentional Radiators. The EUT demonstrated a minimum margin of -5.8 dB below the requirements. Other emissions were present with amplitudes at least 20 dB below the Limits.

Operation in the Band 2400 – 2483.5 MHz

The transmitter output power; harmonic and general emissions were measured on an open area test site @ 3 meters. Test procedures of ANSI C63.4-2009 paragraphs 13.1 and 8.3.1.2 were used during testing. The EUT was placed on a wooden turntable 0.8 meters above the ground plane and at a distance of 3 meters from the FSM antenna. The peak and quasi-peak amplitude of frequencies below 1000 MHz were measured using a spectrum analyzer. The peak and average amplitude of frequencies above 1000 MHz were measured using a spectrum analyzer. The amplitude of each emission was then recorded from the analyzer display. Emissions radiated outside of the specified bands, except for harmonics, shall be attenuated by at least 50 dB below the level of the fundamental or to the general radiated emission limits in 15.209, whichever is the lesser attenuation. Plots were taken of transmitter performance for reference in this and other documentation. Refer to figures one through four showing plots taken of the EUT performance displaying compliance with the specifications. The amplitude of each radiated emission was measured on the OATS at a distance of 3 meters from the FSM antenna (testing was performed on sample 1 representative of production with integral antenna). The amplitude of each radiated emission was maximized by varying the FSM antenna height, polarization, and by rotating the turntable. A Loop antenna was used for measuring emissions from 0.009 to 30 MHz, Biconilog Antenna for 30 to 1000 MHz, Double-Ridge, and/or Pyramidal Horn Antennas from 1 GHz to 25 GHz. Emissions were measured in dB μ V/m @ 3 meters.

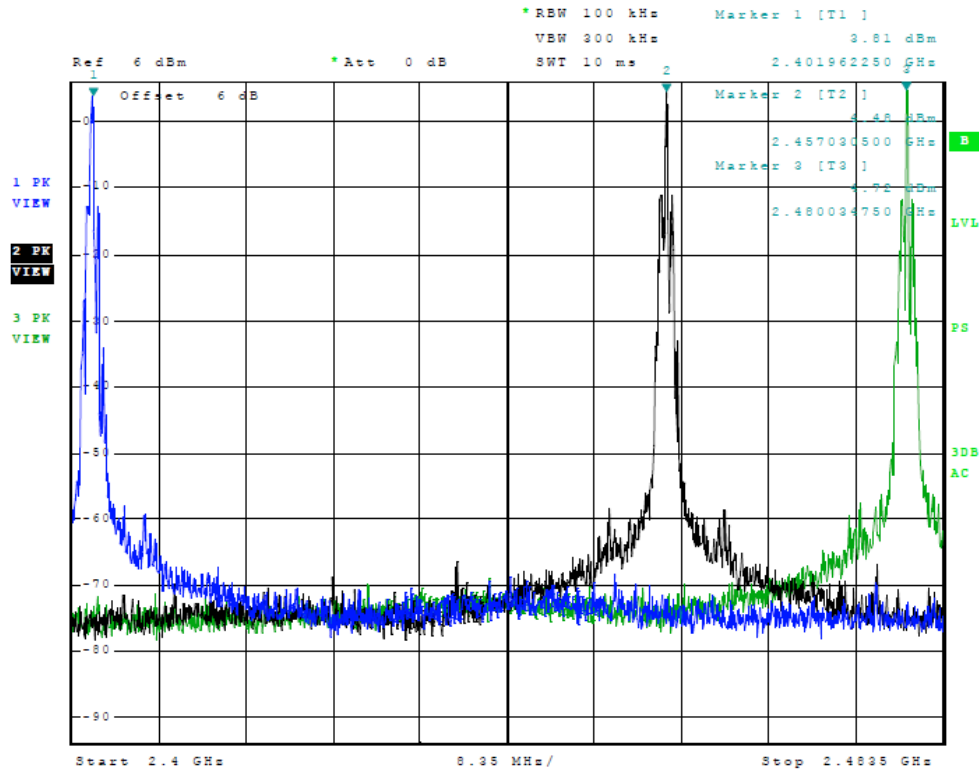

Figure 1 Plot of Transmitter Emissions (Output in Operational Band)

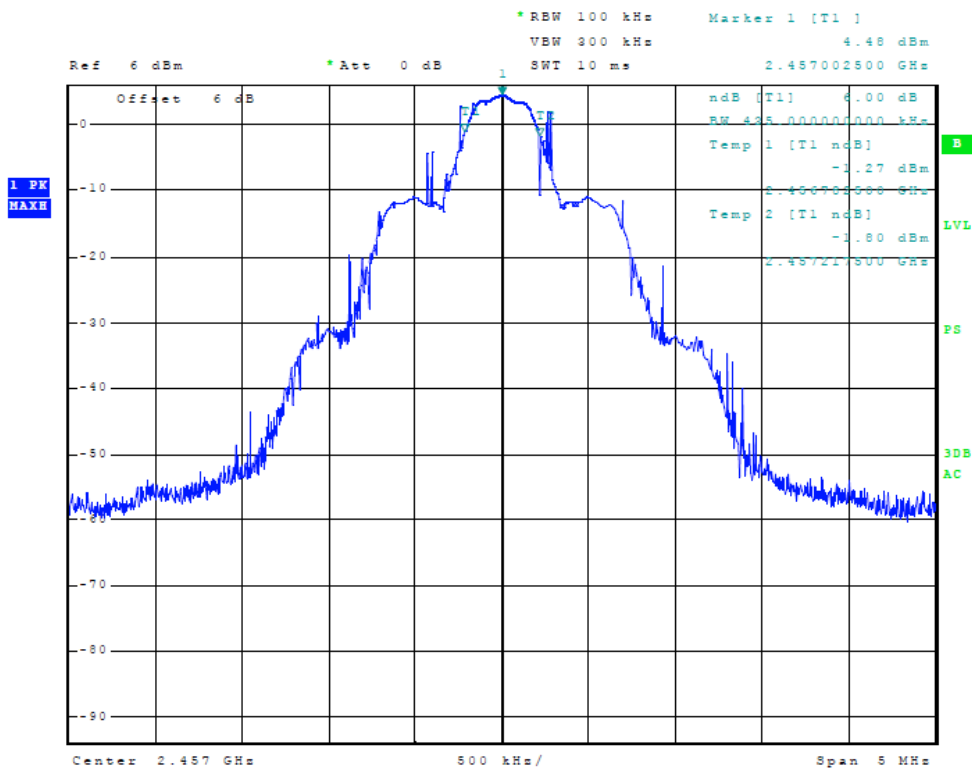

Figure 2 Plot of Transmitter Emissions (Occupied Bandwidth)

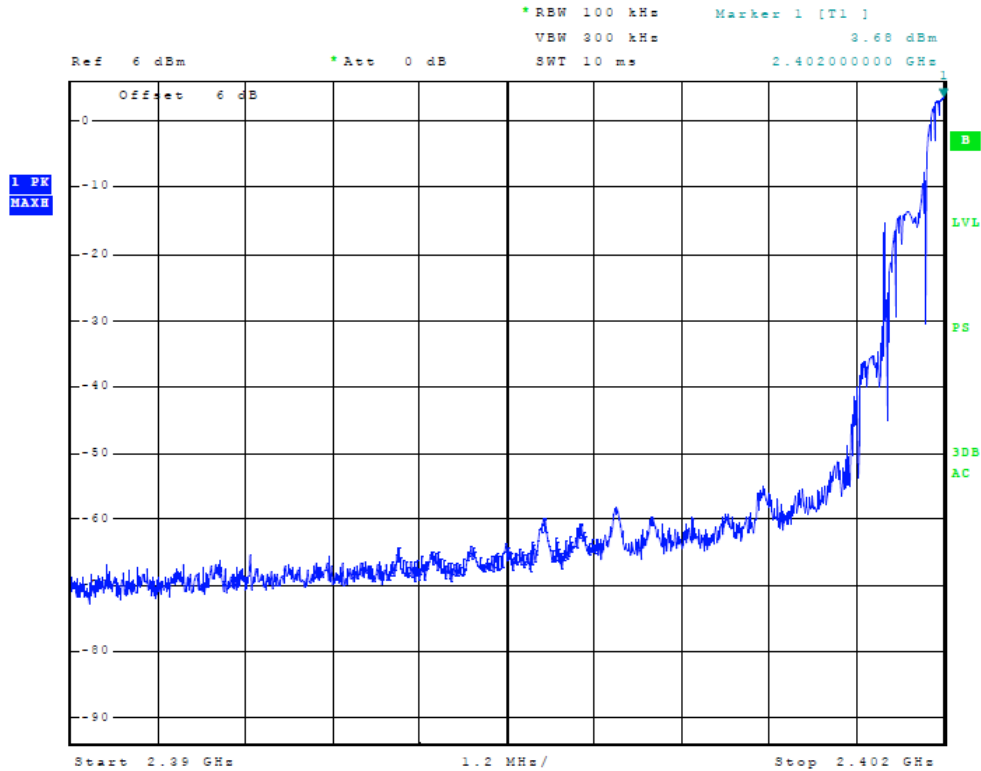

Figure 3 Plot of Transmitter Emissions (Low Band Edge)

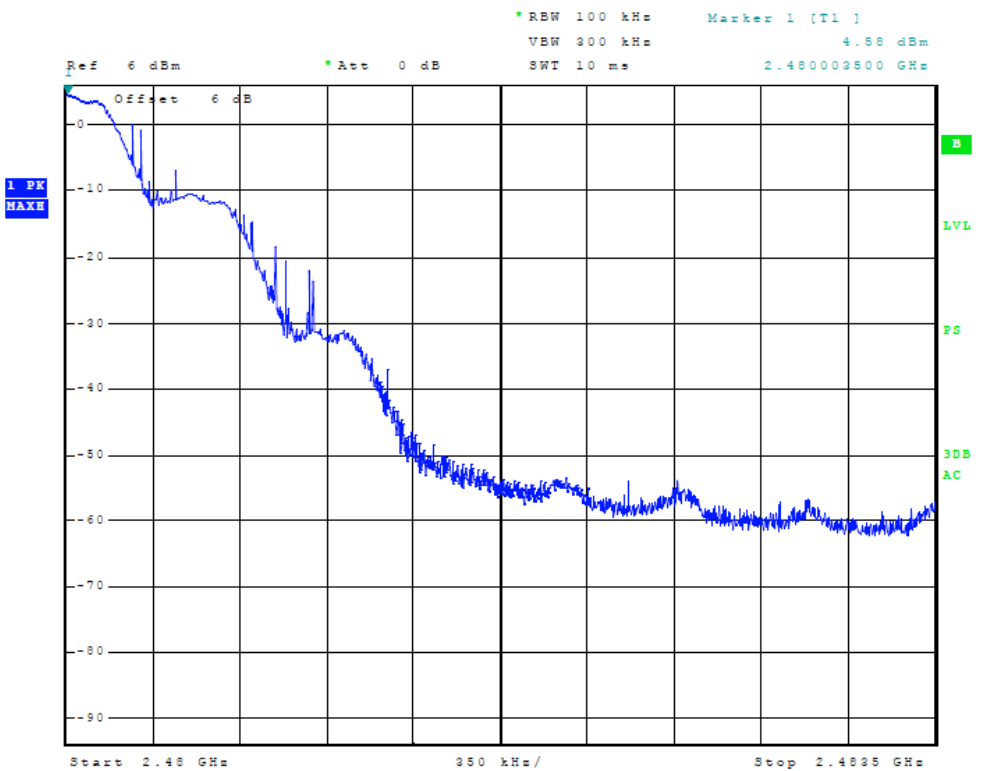

Figure 4 Plot of Low Band Edge (High Band Edge)

Transmitter Emissions Data

Table 4 Transmitter Radiated Emissions

Frequency in MHz	Horizontal Peak (dBµV/m)	Horizontal Quasi-Peak (dBµV/m)	Horizontal Average (dBµV/m)	Vertical Peak (dBµV/m)	Vertical Quasi-Peak (dBµV/m)	Vertical Average (dBµV/m)	Limit @ 3m (dBµV/m)
2402.0	99.5	N/A	48.6	97.6	N/A	44.9	94.0
4804.0	47.6	N/A	35.2	48.2	N/A	35.3	54.0
7206.0	49.2	N/A	36.5	49.1	N/A	36.5	54.0
9608.0	48.6	N/A	35.9	48.8	N/A	36.0	54.0
12010.0	49.1	N/A	36.2	49.1	N/A	36.4	54.0
14412.0	55.7	N/A	43.0	55.7	N/A	43.1	54.0
2457.0	100.1	N/A	47.1	96.4	N/A	44.1	94.0
4914.0	47.6	N/A	34.5	47.7	N/A	34.5	54.0
7371.0	50.3	N/A	36.9	49.5	N/A	37.0	54.0
9828.0	44.2	N/A	32.0	45.3	N/A	32.6	54.0
12285.0	49.1	N/A	36.4	50.5	N/A	37.3	54.0
14742.0	58.8	N/A	45.8	58.7	N/A	46.0	54.0
2480.0	99.2	N/A	46.3	96.8	N/A	44.3	94.0
4960.0	47.8	N/A	35.0	45.0	N/A	32.2	54.0
7440.0	50.8	N/A	37.5	49.1	N/A	36.7	54.0
9920.0	47.5	N/A	34.5	50.3	N/A	37.6	54.0
12400.0	50.1	N/A	37.7	49.6	N/A	37.4	54.0
14880.0	54.7	N/A	42.2	54.5	N/A	42.3	54.0

Other emissions present had amplitudes at least 20 dB below the limit. Peak and Quasi-Peak amplitude emissions are recorded for frequency range below 1000 MHz. Peak and Average amplitude emissions are recorded for frequency range above 1000 MHz.



Summary of Results for Transmitter Radiated Emissions of Intentional Radiator

The EUT demonstrated compliance with the radiated emissions requirements of FCC CFR 47 Part 15.249, RSS-210 and other applicable standards for Intentional Radiators. The EUT worst-case configuration demonstrated minimum margin of -45.4 dB below the limit for average emission limit. The EUT worst-case configuration demonstrated minimum radiated harmonic emission margin of -8.0 dB below the limits. No other radiated emissions were found in the restricted bands less than 20 dB below limits than those recorded in this report. Other emissions were present with amplitudes at least 20 dB below the limits.

Statement of Modifications and Deviations

No modifications to the EUT were required for the unit to demonstrate compliance with the CFR47 Part 15C and RSS-210 emissions standards. There were no deviations to the specifications.



NVLAP Lab Code 200087-0

Annex

- Annex A Measurement Uncertainty Calculations
- Annex B Rogers Labs Test Equipment List
- Annex C Rogers Qualifications
- Annex D FCC Site Registration Letter
- Annex E Industry Canada Site Registration Letter

**Annex A Measurement Uncertainty Calculations**

Measurement uncertainty calculations were made for the laboratory. Result of measurement uncertainty calculations are recorded below for AC line conducted and radiated emission measurements.

Measurement Uncertainty	$U_{(E)}$	$U_{(lab)}$
3 Meter Horizontal 30-200 MHz Measurements	2.08	4.16
3 Meter Vertical 30-200 MHz Measurements	2.16	4.33
3 Meter Vertical Measurements 200-1000 MHz	2.99	5.97
10 Meter Horizontal Measurements 30-200 MHz	2.07	4.15
10 Meter Vertical Measurements 30-200 MHz	2.06	4.13
10 Meter Horizontal Measurements 200-1000 MHz	2.32	4.64
10 Meter Vertical Measurements 200-1000 MHz	2.33	4.66
3 Meter Measurements 1-6 GHz	2.57	5.14
3 Meter Measurements 6-18 GHz	2.58	5.16
AC Line Conducted	1.72	3.43



Annex B Rogers Labs Test Equipment List

List of Test Equipment	Calibration Date
Spectrum Analyzer: Rohde & Schwarz ESU40	5/12
Spectrum Analyzer: HP 8562A, HP Adapters: 11518, 11519, and 11520 Mixers: 11517A, 11970A, 11970K, 11970U, 11970V, 11970W	5/12
Spectrum Analyzer: HP 8591EM	5/12
Antenna: EMCO Biconilog Model: 3143	5/12
Antenna: Sunol Biconilog Model: JB6	10/12
Antenna: EMCO Log Periodic Model: 3147	10/12
Antenna: Com Power Model: AH-118	10/12
Antenna: Com Power Model: AH-840	10/12
Antenna: Antenna Research Biconical Model: BCD 235	10/12
LISN: Compliance Design Model: FCC-LISN-2.Mod.cd, 50 µHy/50 ohm/0.1 µf	10/12
R.F. Preamp CPPA-102	10/12
Attenuator: HP Model: HP11509A	10/12
Attenuator: Mini Circuits Model: CAT-3	10/12
Attenuator: Mini Circuits Model: CAT-3	10/12
Cable: Belden RG-58 (L1)	10/12
Cable: Belden RG-58 (L2)	10/12
Cable: Belden 8268 (L3)	10/12
Cable: Time Microwave: 4M-750HF290-750	10/12
Cable: Time Microwave: 10M-750HF290-750	10/12
Frequency Counter: Leader LDC825	2/13
Oscilloscope Scope: Tektronix 2230	2/13
Wattmeter: Bird 43 with Load Bird 8085	2/13
Power Supplies: Sorensen SRL 20-25, SRL 40-25, DCR 150, DCR 140	2/13
R.F. Generators: HP 606A, HP 8614A, HP 8640B	2/13
R.F. Power Amp 65W Model: 470-A-1010	2/13
R.F. Power Amp 50W M185- 10-501	2/13
R.F. Power Amp A.R. Model: 10W 1010M7	2/13
R.F. Power Amp EIN Model: A301	2/13
LISN: Compliance Eng. Model 240/20	2/13
LISN: Fischer Custom Communications Model: FCC-LISN-50-16-2-08	2/13
Antenna: EMCO Dipole Set 3121C	2/13
Antenna: C.D. B-101	2/13
Antenna: Solar 9229-1 & 9230-1	2/13
Antenna: EMCO 6509	10/12
Audio Oscillator: H.P. 201CD	2/13
ELGAR Model: 1751	2/13
ELGAR Model: TG 704A-3D	2/13
ESD Test Set 2010i	2/13
Fast Transient Burst Generator Model: EFT/B-101	2/13
Field Intensity Meter: EFM-018	2/13
KEYTEK Ecat Surge Generator	2/13
Shielded Room 5 M x 3 M x 3.0 M	



Annex C Rogers Qualifications

Scot D. Rogers, Engineer

Rogers Labs, Inc.

Mr. Rogers has approximately 17 years' experience in the field of electronics. Engineering experience includes six years in the automated controls industry and remaining years working with the design, development and testing of radio communications and electronic equipment.

Positions Held

Systems Engineer: A/C Controls Mfg. Co., Inc. 6 Years

Electrical Engineer: Rogers Consulting Labs, Inc. 5 Years

Electrical Engineer: Rogers Labs, Inc. Current

Educational Background

- 1) Bachelor of Science Degree in Electrical Engineering from Kansas State University.
- 2) Bachelor of Science Degree in Business Administration Kansas State University.
- 3) Several Specialized Training courses and seminars pertaining to Microprocessors and Software programming.

Scot D. Rogers



NVLAP Lab Code 200087-0

Annex D FCC Site Registration Letter

FEDERAL COMMUNICATIONS COMMISSION

**Laboratory Division
7435 Oakland Mills Road
Columbia, MD 21046**

November 01, 2011

Registration Number: 90910

Rogers Labs, Inc.
4405 West 259th Terrace,
Louisburg, KS 66053

Attention: Scot Rogers,

Re: Measurement facility located at Louisburg
3 & 10 meter site
Date of Renewal: November 01, 2011

Dear Sir or Madam:

Your request for renewal of the registration of the subject measurement facility has been received. The information submitted has been placed in your file and the registration has been renewed. The name of your organization will remain on the list of facilities whose measurement data will be accepted in conjunction with applications for Certification under Parts 15 or 18 of the Commission's Rules. Please note that the file must be updated for any changes made to the facility and the registration must be renewed at least every three years.

Measurement facilities that have indicated that they are available to the public to perform measurement services on a fee basis may be found on the FCC website www.fcc.gov under E-Filing, OET Equipment Authorization Electronic Filing, Test Firms.

Sincerely,

Phyllis Parrish
Industry Analyst

Rogers Labs, Inc.
4405 W. 259th Terrace
Louisburg, KS 66053
Phone/Fax: (913) 837-3214
Revision 1

Garmin International, Inc.
Model: M3BPGT00 SN: 3860566770
Test #: 130408
Test to: CFR47 (15.249), RSS-210
File: Garmin M3BPGT00 DXX TstRpt 130408

FCC ID#: IPH-02117
IC: 1792A-02117
Date: Date: May 15, 2013
Page 29 of 30



NVLAP Lab Code 200087-0

Annex E Industry Canada Site Registration Letter



December 28, 2011

OUR FILE: 46405-3041
Submission No: 152685

Rogers Labs Inc.
4405 West 259th Terrance
Louisburg, KS, 66053
USA

Attention: Mr. Scot D. Rogers

Dear Sir/Madame:

The Bureau has received your application for the renewal of 3/10m OATS. Be advised that the information received was satisfactory to Industry Canada. The following number(s) is now associated to the site(s) for which registration / renewal was sought (**Site# 3041A-1**). Please reference the appropriate site number in the body of test reports containing measurements performed on the site. In addition, please keep for your records the following information;

- The company address code associated to the site(s) located at the above address is: **3041A**

Furthermore, to obtain or renew a unique site number, the applicant shall demonstrate that the site has been accredited to ANSI C63.4-2003 or later. A scope of accreditation indicating the accreditation by a recognized accreditation body to ANSI C63.4-2003 or later shall be accepted. Please indicate in a letter the previous assigned site number if applicable and the type of site (example: 3 metre OATS or 3 metre chamber). If the test facility is not accredited to ANSI C63.4-2003 or later, the test facility shall submit test data demonstrating full compliance with the ANSI standard. The Bureau will evaluate the filing to determine if recognition shall be granted.

The frequency for re-validation of the test site and the information that is required to be filed or retained by the testing party shall comply with the requirements established by the accrediting organization. However, in all cases, test site re-validation shall occur on an interval not to **exceed three years**. There is no fee or form associated with an OATS filing. OATS submissions are encouraged to be submitted electronically to the Bureau using the following URL;
http://strategis.ic.gc.ca/epic/internet/inceb-bhst.nsf/en/h_tt00052e.html.

If you have any questions, you may contact the Bureau by e-mail at certification.bureau@ic.gc.ca Please reference our file and submission number above for all correspondence.

Yours sincerely,

Dalwinder Gill
For: Wireless Laboratory Manager
Certification and Engineering Bureau
3701 Carling Ave., Building 94
P.O. Box 11490, Station "H"
Ottawa, Ontario K2H 8S2
Email: dalwinder.gill@ic.gc.ca
Tel. No. (613) 998-8363
Fax. No. (613) 990-4752

Rogers Labs, Inc.
4405 W. 259th Terrace
Louisburg, KS 66053
Phone/Fax: (913) 837-3214
Revision 1

Garmin International, Inc.
Model: M3BPGT00 SN: 3860566770
Test #: 130408
Test to: CFR47 (15.249), RSS-210
File: Garmin M3BPGT00 DXX TstRpt 130408

FCC ID#: IPH-02117
IC: 1792A-02117
Date: Date: May 15, 2013
Page 30 of 30