



GMR™ 600/1200 Series Radar Installation Instructions

Properly install your GMR 600/1200 series radar according to the following instructions. **If you experience difficulty installing the chartplotter, seek the assistance of a professional installer, or contact Garmin® Product Support.**

Before installing your GMR 600/1200 series radar, confirm that the package contains the items listed on the box. If any parts are missing, contact your Garmin dealer immediately.



See the *Important Safety and Product Information* guide in the product box for product warnings and other important information.



WARNING: Always wear safety goggles, ear protection, and a dust mask when drilling, cutting, or sanding.



WARNING: The selected radar mounting location must be able to hold the weight of the radar and withstand any inertial forces.



WARNING: The radar transmits electromagnetic energy. It is important that the radar is turned off or the DC power input is disconnected when personnel are required to come close to the radar to perform work on the radar assembly or associated equipment. Electromagnetic energy is harmful.



CAUTION: When the radar is transmitting, do not look directly at the antenna at close range, because the eyes are the most sensitive part of the body to electromagnetic energy.



NOTICE: When drilling or cutting, always check the opposite side of the drilling or cutting surface.

Product Registration

Help us better support you by completing our online registration today. Go to <http://my.garmin.com>. Keep the original sales receipt, or a photocopy, in a safe place.

Contact Garmin

Contact Garmin Product Support if you have any questions while installing your GMR 600/1200 series radar. In the USA, go to www.garmin.com/support, or contact Garmin USA by phone at (913) 397.8200 or (800) 800.1020.

In the UK, contact Garmin (Europe) Ltd. by phone at 0808 2380000.

In Europe, go to www.garmin.com/support and click **Contact Support** for in-country support information, or contact Garmin (Europe) Ltd. by phone at +44 (0) 870.8501241.

Needed Tools

For Installing the Radar:

- #2 Phillips screwdriver
- 5 mm Allen wrench
- Drill and drill bits
- Wrench and socket set

For Installing the Optional Field-Installable RJ-45 Network Connector:

- Knife
- Pliers
- 15 mm wrench
- AMP modular-plug hand tool and die set or compatible equivalent

Selecting a Location

When selecting a location to install the GMR 600/1200 series radar, consider the following:

- An ideal mounting location is high above the keel line of the ship with a minimal part of the structure or rigging blocking the radar beam. Obstructions in the path of the radar beam may cause blind and shadow sectors, or generate false echoes. The higher the installation position, the farther the radar can detect targets.
- Avoid mounting on the same level as smoke stacks, horizontal spreaders, or crosstrees on a mast.
- Do not install the radar near heat sources where it may be exposed to smoke or hot air from smoke stacks or heat from lights.
- The mounting surface or platform should be sturdy enough to support the weight of the radar and any inertial forces, as flat as possible, and parallel with the water line.
- Garmin recommends mounting the radar out of range of personnel (horizontal beam width above head height). When properly installed and operated, the use of this radar conforms to the requirements of ANSI/IEEE C95.1-1992 Standard for Safety Levels with Respect to Human Exposure to Radio Frequency Electromagnetic Fields.

IEC 60936-1 clause 3-27.1 states maximum distances from the antenna at which Radio Frequency (RF) levels can be expected.

- GMR 604 (100W/m squared = 67 in. [1.7 m]) (10W/m squared = 217 in. [5.5 m])
- GMR 606 (100W/m squared = 79 in. [2 m]) (10W/m squared = 244 in. [6.2 m])
- GMR 1204 (100W/m squared = 99 in. [2.5 m]) (10W/m squared = 307 in. [7.8 m])
- GMR 1206 (100W/m squared = 111 in. [2.8 m]) (10W/m squared = 343 in. [8.7 m])

 **CAUTION:** When the radar is transmitting, do not look directly at the antenna at close range (the eyes are the most sensitive part of the body to electromagnetic energy).

- A compass safe distance must be maintained between the compass and the radar. The compass safe distance is measured from the center point of the compass to the nearest point on the radar.
 - Standard compass = 35 ⁷/₁₅ in. (90 cm)
 - Standby Steering and Emergency compasses = 31 ¹/₂ in. (80 cm)
- Mount other electronics and cables more than 7 ft. (2 m) from the path of a radar beam. A radar beam can spread 25° vertically above and below the radiating element of the radar. For vessels with higher bow angles at cruise speed, you can lower the angle so that the beam points slightly downward to the waterline while at rest. Shims may be used as necessary.
- Install the radar away from antennas or other electronics. GPS antennas should be located above or below the radar beam path of the radar. Mount at least 3 ft. (1 m) from any equipment transmitting or cables carrying radio signals, such as VHF radios, cables, and antennas. In the case of SSB radios, the distance should be increased to 7 ft. (2 m).

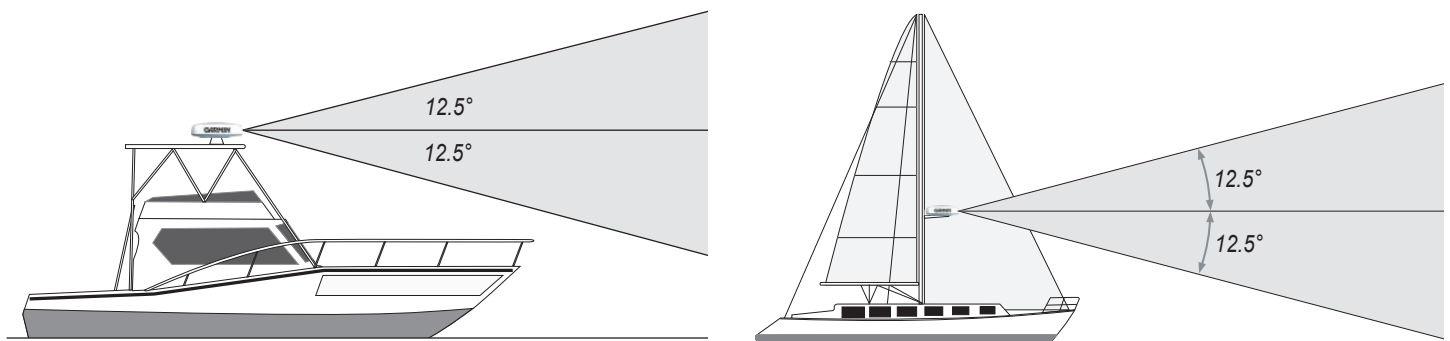

Installing the Mounting Studs and Seals

1. Remove the hatch on the front of pedestal by loosening the screw and lifting the hatch off of the hinges as shown in Figure 1.
2. Use a 5 mm Allen wrench, to install the M10 x 71 mounting studs (Figure 2) in the pedestal matching the hole pattern that was selected. Tighten the mounting studs until they bottom out in the pedestal. Do not overtighten the studs to avoid damaging the pedestal. The mounting studs have a thread-locking patch applied at the factory.

Optional: Apply moisture-inhibitive grease or paste to the four studs prior to installation.

3. Install the seals onto the pedestal (Figure 3).



Figure 1

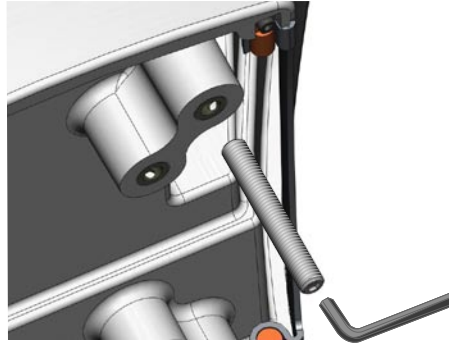

Figure 2

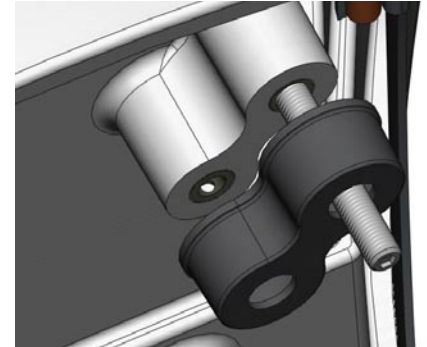

Figure 3

Mounting the Radar

Mount the radar with either end pointed toward the bow. Ensure it is mounted along the Bow-Stern Axis line indicated on the *GMR 400/600/1200 Series Mounting Template*. If the end with the hatch is pointed toward the bow, the Front of Boat Offset setting on the chartplotter must be set to 180° (Figure 4). To adjust the Front of Boat Offset on the chartplotter, see [page 7](#).

To mount the radar:

1. (Skip to step two if you are using a pre-drilled Garmin compatible Furuno® or Raymarine® mount.) Determine a suitable mounting location and tape the Mounting Template in place. The Mounting Template has two hole patterns: Option A and Option B. Determine the most appropriate patterns from the two patterns available on the Mounting Template (Option A or Option B). Use a 1/2 in. (13 mm) bit to drill the four mounting holes.
2. Hoist the radar into position using the supplied strap. Position the strap over the ends of the antenna mount as shown in Figure 5. Ensure that you position the strap as close to the radar as possible.
3. Fasten the radar to the mounting surface using the M10 hex nuts, spring washers, and flat washers in the order shown in Figure 6. The M10 nuts should be torqued to 130 lbf-in (11 lbf-ft) (1.5 kgf-m).

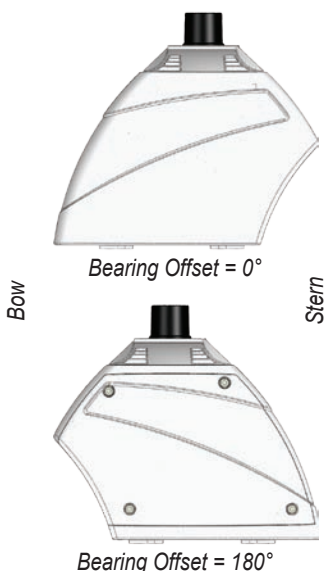

Figure 4

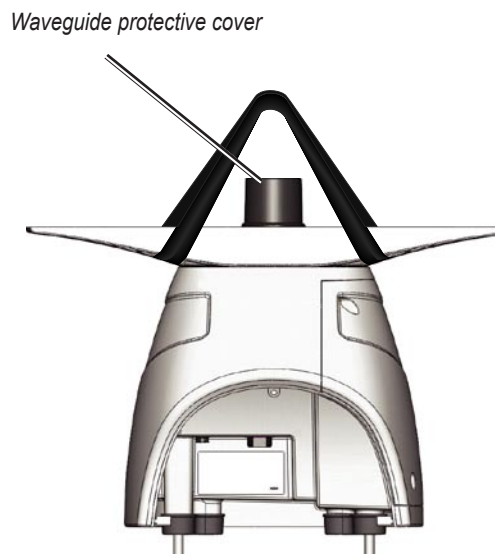

Figure 5

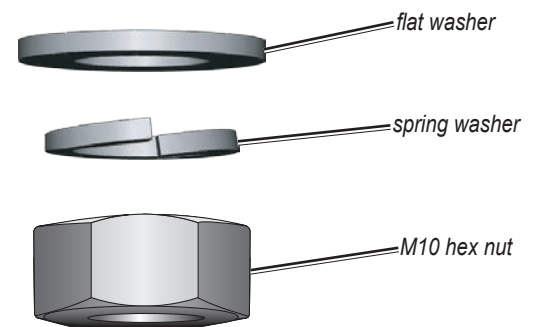
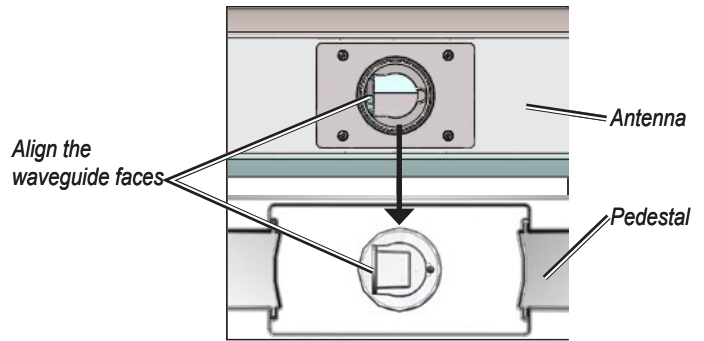

Figure 6

Mounting the Antenna

1. Remove the protective cover from the pedestal wave guide.
2. Verify that the antenna wave guide is aligned with the pedestal wave guide. Slide the antenna onto the pedestal.
3. Secure the antenna to the pedestal using the 8 mm hex bolts and spring washers. The 8 mm bolts should be torqued to 70 lbf-in (6 lbf-ft) (.81 kgf-m).



Installing the Voltage Converter Unit

The included voltage converter unit is needed to supply a specific constant voltage to the radar. When installing the voltage converter unit, consider the following:

- The voltage converter requires an input voltage of 10–40 Vdc (20–40 Vdc for the GMR 1204 and GMR 1206).
- You must connect the converter to the boat battery through a 15 A slow-blow fuse.
- Garmin recommends that you install the voltage converter as close as possible to the selected power source.
- For optimal performance, connect the voltage converter housing to the RF ground of the vessel.
- If the input wires need to be extended, follow the recommendations in the wire gauge table.
 - If the wires are extended, use the supplied heat-shrink butt connectors.
 - After the connector is crimped, heat the connector to shrink it and provide a water resistant fit.

Distance	Gauge
9 ft. 10 in. (3 m)	12 AWG
16 ft. 4 in. (5 m)	10 AWG
21 ft. 3 in. (6.5 m)	9 AWG
26 ft. 2 in. (8 m)	8 AWG

Wire Gauge Table

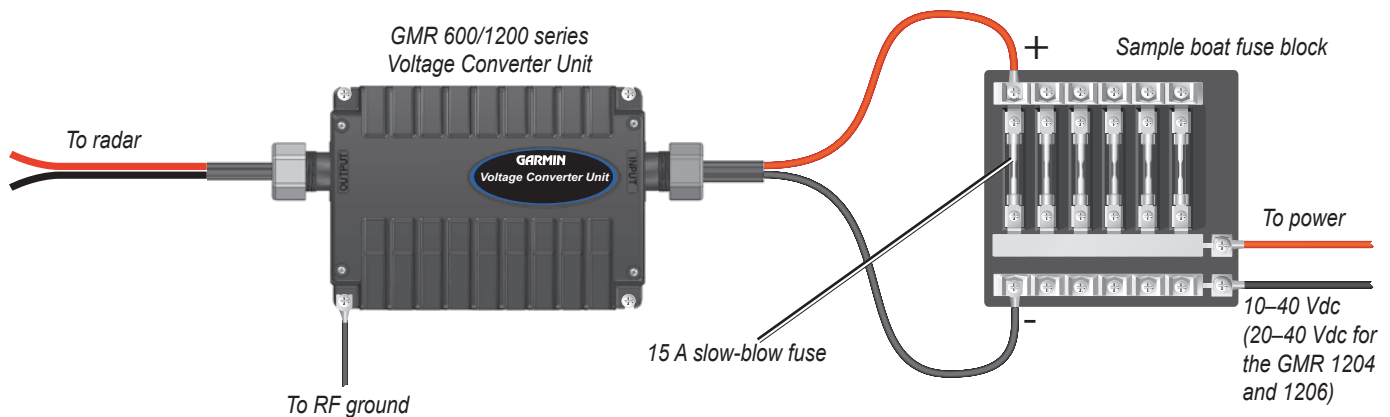

Connecting the Voltage Converter to a Boat Fuse Block

Installing the Power and Network Cables

Route the cable as needed, based on the type of mount you are using.

When installing the power and network cables, consider the following:

- To ensure safety, use the appropriate tie-wraps, fasteners, and sealant to secure the cable along a route and through any bulkhead or deck. Avoid running the cable near moving objects, high-heat sources, or through doorways and bilges.
- Avoid installing the cable next to or parallel to other cables, such as radio antenna lines or power cables. This is essential to avoid interference to or from other equipment. If this is not possible, shield the cable with metal conduit or a form of EMI shielding.
- You may need to drill a 1 1/4 in. (31.7 mm) hole for routing the power/network cable. Garmin provides a rubber cable grommet to cover the cable installation hole.
 - The grommet does NOT provide a waterproof seal. To waterproof the grommet, apply a marine sealant.
 - You can purchase additional cable grommets through Garmin or a Garmin dealer.
- Use the optional field-installable RJ-45 network connector (included) to create a custom-length Garmin Marine Network cable if needed (see [page 8](#)).

To install the cable assembly:

1. Align the notch and locking ring on the power cable to the power connector. Press the 2-pin power cable to the power connector. Tighten the power-cable locking ring clockwise until it is firmly sealed..
2. Press the RJ-45 marine network cable to the RJ-45 socket. Tighten the RJ-45 locking ring clockwise until it is firmly sealed.
3. Route the power and network cables through the front of the radar (Figure 7), or through a hole drilled through the mounting surface (Figure 8). Avoid excessively bending or twisting the cables.
4. Install the hatch on the front of the radar.

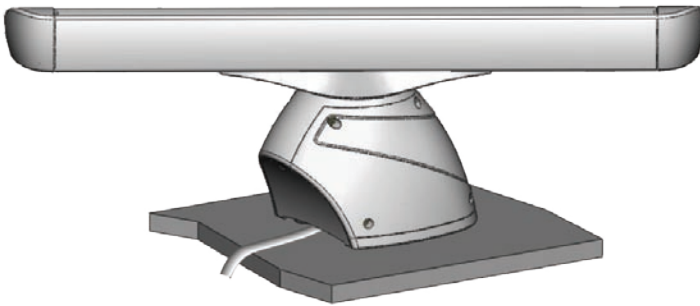
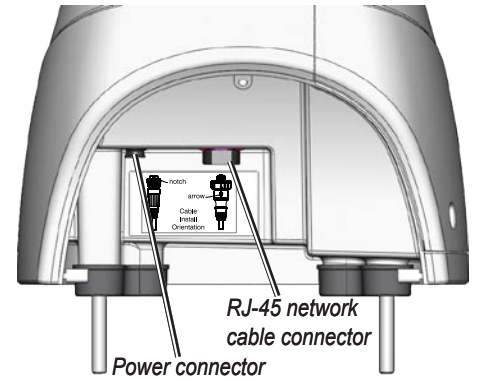

Figure 7

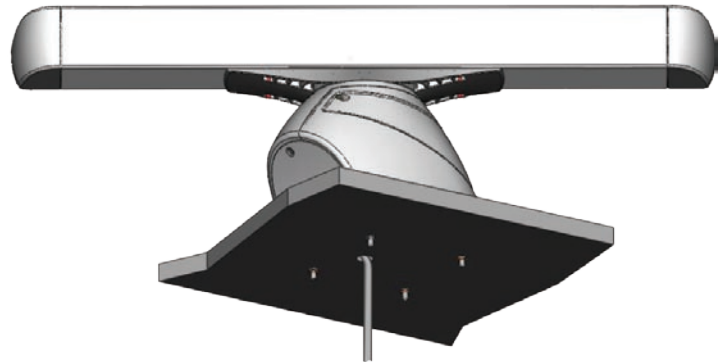

Figure 8

Connecting the Radar to Power Through the Voltage Converter

Connect the radar power cable (red and black) to the voltage converter output cable (red and black) using the supplied heat-shrink crimp connectors. After crimping the connections, heat the connectors to shrink the housing for a water resistant fit.

NOTICE: If you choose to cut the radar power cable, you must reconnect the in-line fuse holder.

Connect the radar to the water ground of the vessel using an 8 gauge copper cable (not included). Secure the ground wire to the radar housing using one of the four mounting studs, an M10 nut, and flat washer.

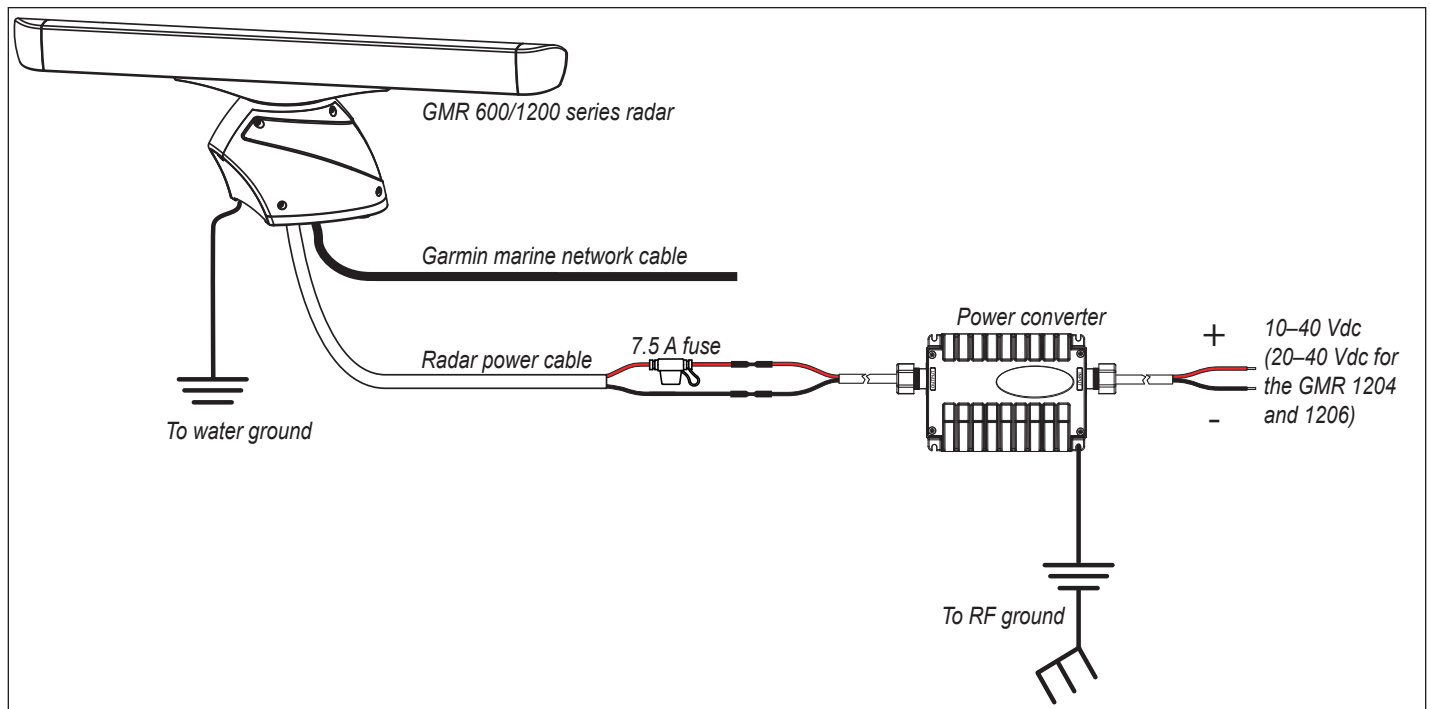

Power Wiring Diagram

Connecting the Radar to the Garmin Marine Network

For a stand-alone network (chartplotter and radar only), attach the RJ-45 marine network cable to the RJ-45 socket on the back of the chartplotter. For an expanded network (including a chartplotter, radar, a GMS 10, etc.), attach the RJ-45 marine network cable to an open RJ-45 socket on the GMS 10 network expander. Tighten the RJ-45 locking ring clockwise until it is firmly sealed.

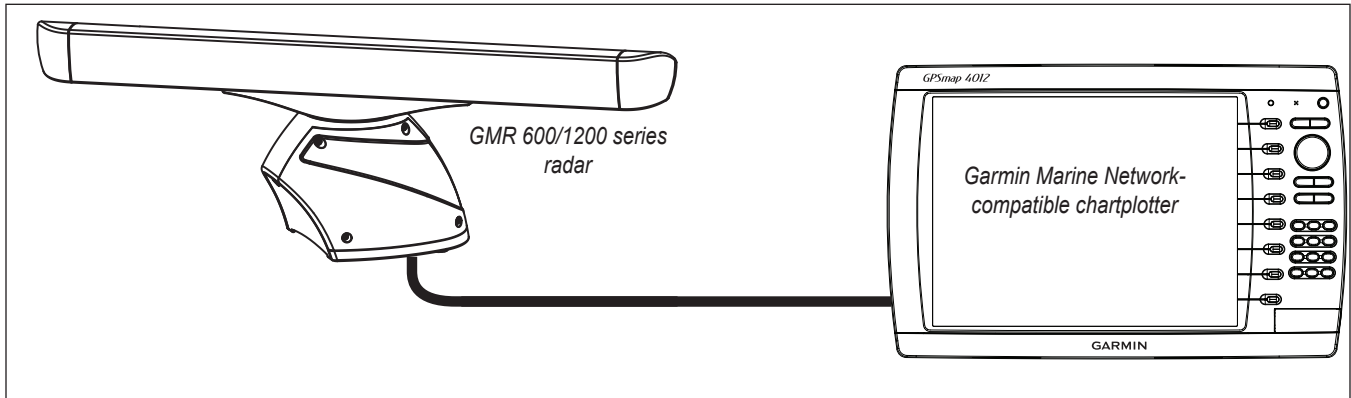

Stand-Alone Garmin Marine Network Example

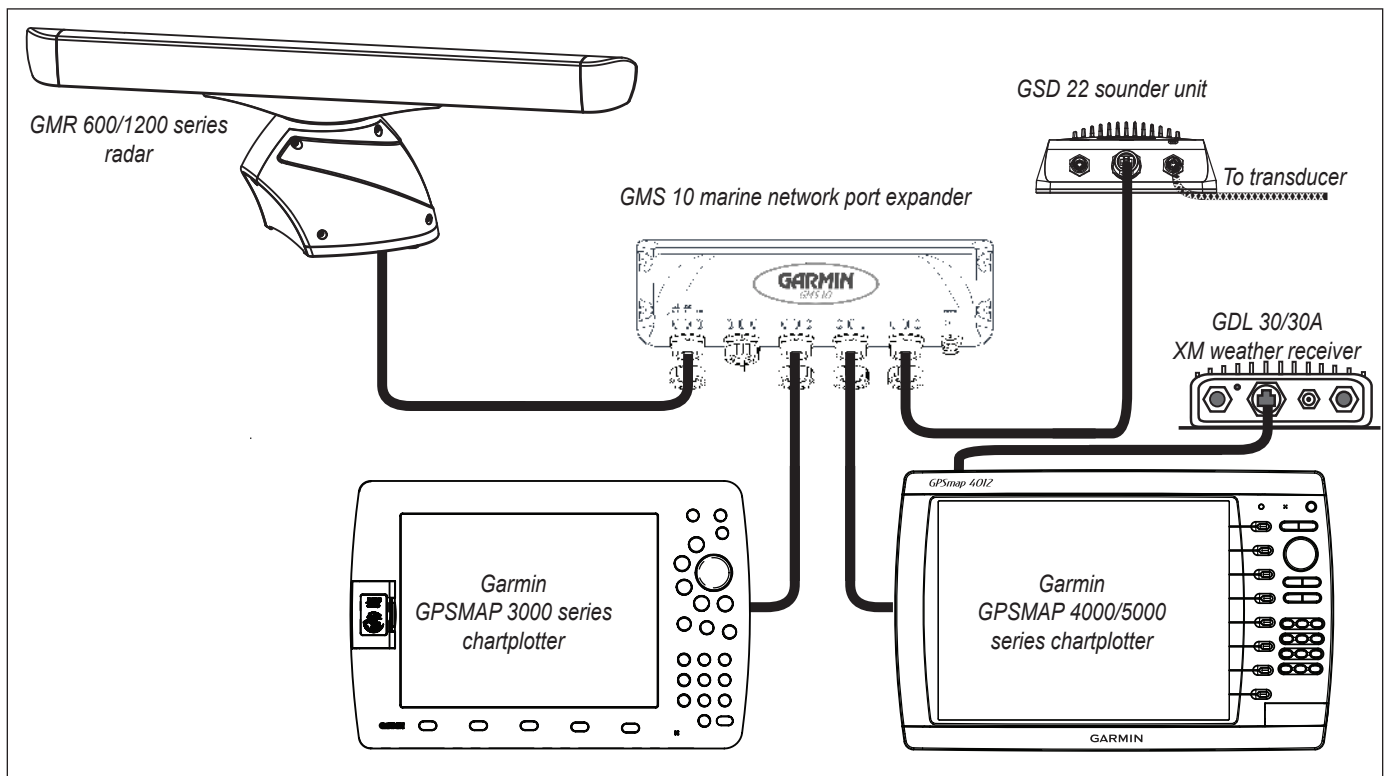

Expanded Garmin Marine Network Example

NOTE: Each component of the expanded network must be installed according to its installation instructions. These diagrams only show how a GMR 404/406 radar interacts with a network and do not show proper wiring for other network components.

NOTE: Every device connected to the Garmin Marine Network must be connected to the power supply for the boat. These diagrams show the network connections; however, they do not show the power connections. Wire each device according to the appropriate installation instructions.

Configuring the Radar

After you install the radar, you must prepare the chartplotter or the Garmin Marine network to properly use the radar.

1. Update the chartplotter or Garmin Marine Network software.
2. Enter the radar antenna size.
3. Set the Front of Boat Offset if necessary.

Updating the Chartplotter or the Garmin Marine Network

If you have a GPSMAP 4000 or 5000 series chartplotter, use a blank SD card to update the chartplotter or the network according to the instructions in the chartplotter owner's manual.

If you have a GPSMAP 3000 series chartplotter, use a blank Garmin Data Card to update the chartplotter or the network according to the instructions in the chartplotter owner's manual.

Download the latest software from www.garmin.com.

Entering the Radar Antenna Size

Using a chartplotter, specify the size of your radar antenna (4 foot or 6 foot). Until you specify the antenna size, the warning "Radar Needs Configured" appears on the chartplotter.

NOTE: Ensure you specify the correct antenna size on your chartplotter to obtain optimum performance.

To enter the radar antenna size on a GPSMAP 4000 or 5000 series chartplotter:

1. From the Home screen, select **Radar > Harbor (or Offshore)**.
2. From the Radar screen, select **Menu > Radar Setup > Antenna Size**.
3. Select the correct antenna size, **4 foot** or **6 foot**.

To enter the radar antenna size on a GPSMAP 3000 series chartplotter:

1. Press the **PAGE** key to switch to the Radar page.
2. Press the **Setup** softkey to open the setup page.
2. Using the **ROCKER**, highlight the **Advanced** tab, then the **Antenna Size** field, and press **ENTER**.
3. Select the correct antenna size, **4 foot** or **6 foot**, and press **ENTER**.

Changing the Front of Boat Offset

Depending on the radar installation, you may need to change the Front of Boat Offset. If the radar installation requires a 180° offset, change the Front of Boat Offset to 180° and test the radar. If the Front of Boat Offset needs further adjustment, measure the radar offset and change the offset using the following procedures.

To measure potential radar offset:

1. Using a magnetic compass, take an optical bearing of a stationary target located within viewable range.
2. Measure the target bearing on the radar.
3. If the bearing deviation is more than +/- 1°, further correct the Front of Boat Offset.

To change the Front of Boat Offset on a GPSMAP 4000 or 5000 series chartplotter:

1. From the Home screen, select **Radar > Harbor (or Offshore)**.
2. From the Radar screen, select **Radar Setup > Front of Boat**.
3. Enter an offset value, then select **Back**.

To change the Front of Boat Offset:

1. From the Radar page, press the **Setup** softkey to open the setup page.
2. From the Setup page, using the **ROCKER**, select the **Advanced** tab.
3. Highlight the **Front of Boat Offset** slider, and press **ENTER**.
4. Adjust the value accordingly. The preview window changes as you adjust the slider.
5. After an offset is determined, press **ENTER** to save, and press **QUIT** to return to the Radar page.

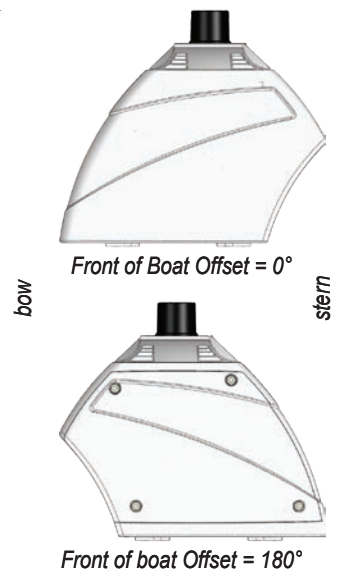

Installing the Field-Installable RJ-45 Network Connector (Optional)

A field-installable RJ-45 network connector is provided for you to create a network cable that is the correct length for your installation.

- 1 O-Ring
 - 2 RJ-45 modular plug
 - 3 Ethernet cable termination
- Copper tape strip (not shown)



Preparing the Network Cable

1. Cleanly cut your Ethernet cable to the desired length. Retain the cut RJ-45 connector for Step 4.
2. Remove the strain-relief nut from the cable-connection housing and slide it onto the cut end of the cable as shown.
3. Feed the cut cable end through the connection housing as shown.

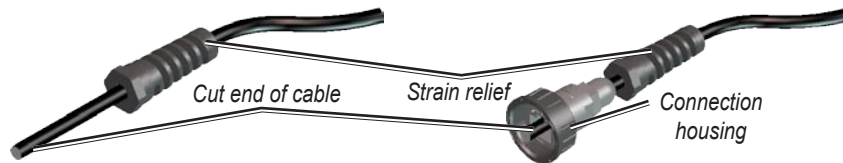

4. Examine the RJ-45 connector removed in Step 1 and compare it to the wire positions in the table below. Note which cable side, A or B, was removed in Step 1.

Position	Wire Color—Main/Stripe	
	Side A	Side B
1	White/Orange	White/Green
2	Orange	Green
3	White/Green	White/Orange
4	Blue	Blue
5	White/Blue	White/Blue
6	Green	Orange
7	White/Brown	White/Brown
8	Brown	Brown

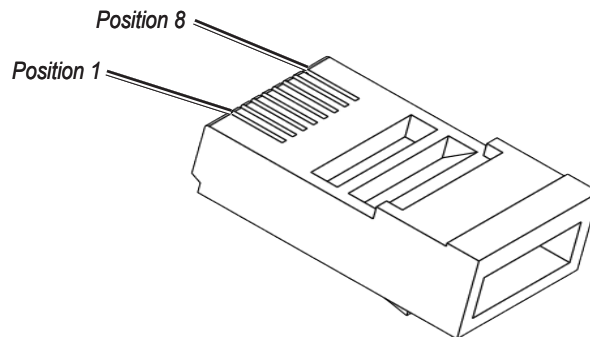

NOTE: The Garmin Marine Network requires cross-over cables not exceeding 100 meters between devices. When constructing a custom cable from bulk wire, you must create both a Side A and Side B.

5. Prepare the cable for plug installation:

- Using a sharp knife, insert the blade between the cable shield and jacket. Slit the jacket $\frac{5}{8}$ " back from the trimmed end of the cable.
- Peel the jacket back and remove the slit portion.
- Trim the shield and Mylar film away from wires. Be careful not to cut any of the wires.
- Fold the drain wire back over the jacket and trim to approximately $\frac{9}{16}$ in. (14 mm).
- Untwist the wire pairs enough to ensure a proper connection.
- Arrange individual wires in proper order according to the table shown above. For example, if you have identified the end of the cable in Step 4 as Side A, arrange the wires for Side A. If you are constructing a custom cable from bulk wire, you need to make both a Side A and a Side B connection.
- Trim the wire ends to an even length, leaving approximately $\frac{9}{16}$ in. (14 mm) from the ends to the jacket edge.
- Place the drain wire on the jacket. Wrap the supplied copper tape around cable as close to the edge of the jacket as possible.
- Using a pair of pliers, squeeze the copper tape to pre-form the cable jacket end for easier insertion into the plug. Use caution to avoid damaging the copper tape.

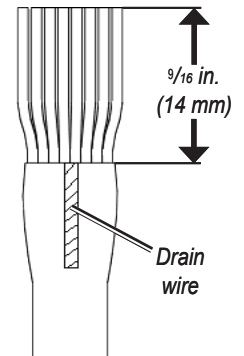

Installing the Network Connector

1. Keeping the wires in proper sequence, insert them into the modular plug until the ends bottom out inside the plug. Visually inspect the wires to verify proper order before continuing. If any wires are not in the correct position, remove the plug and rearrange the wires.

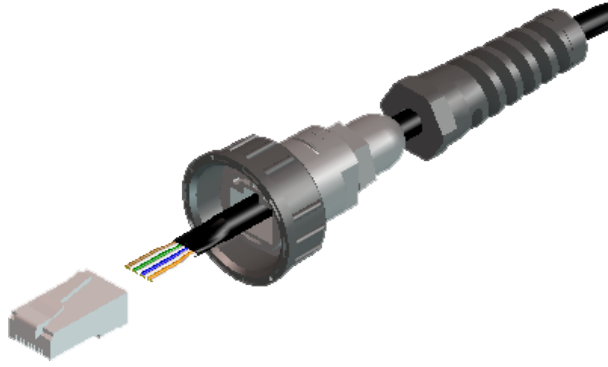

2. Using an AMP Modular Plug Hand Tool and Die Set (or compatible equivalent), crimp the plug onto the wires following the recommended procedure of the crimp-tool manufacturer.
3. After the plug is crimped, align the release tab on the plug with the corresponding notch in the cable-connection housing. Depress the tab and push the cable through the connection housing until the plug is securely seated in the plug cavity.

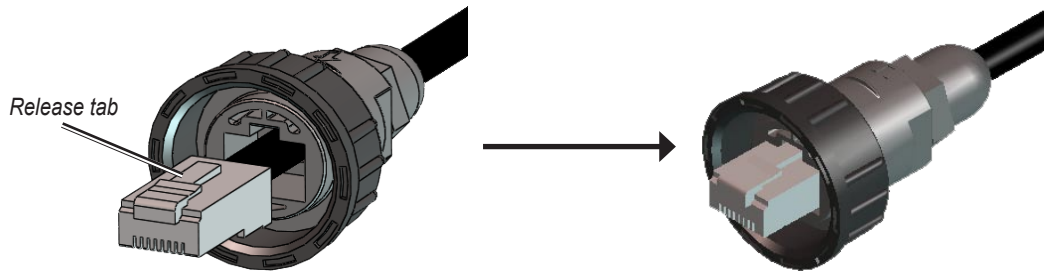

4. Screw the strain relief nut onto the housing and tighten it snugly with a 15 mm wrench. Be careful not to overtighten the nut.



5. Install the O-ring onto the housing. The cable is now ready to use.

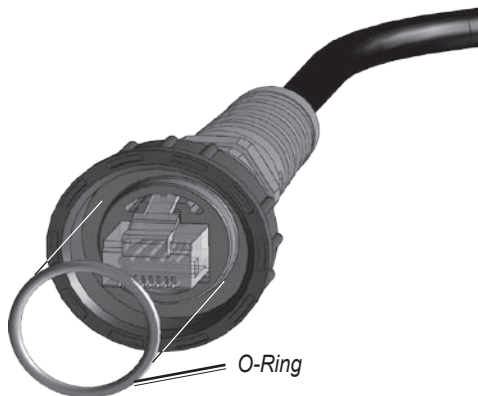

Unit Dimensions

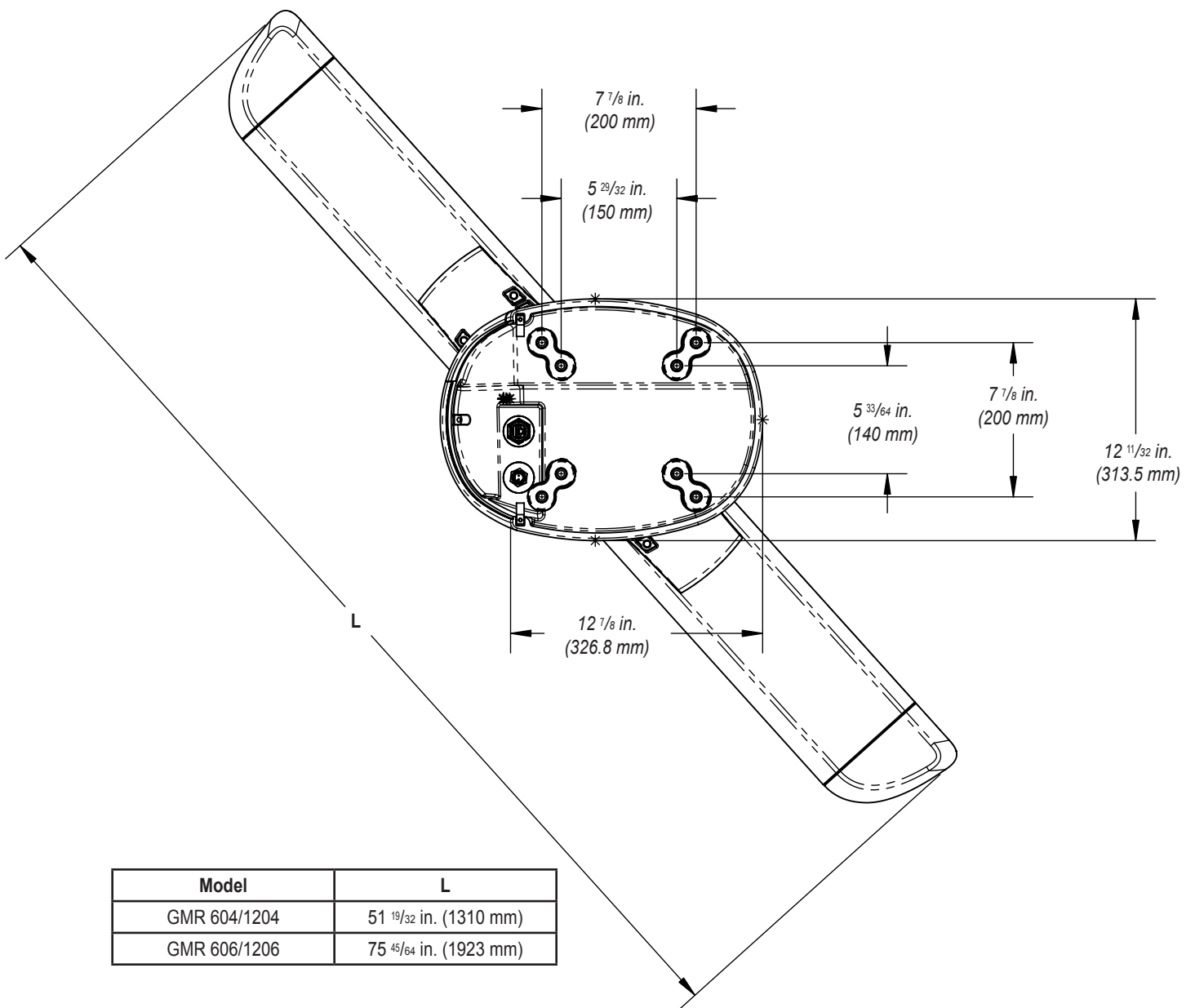
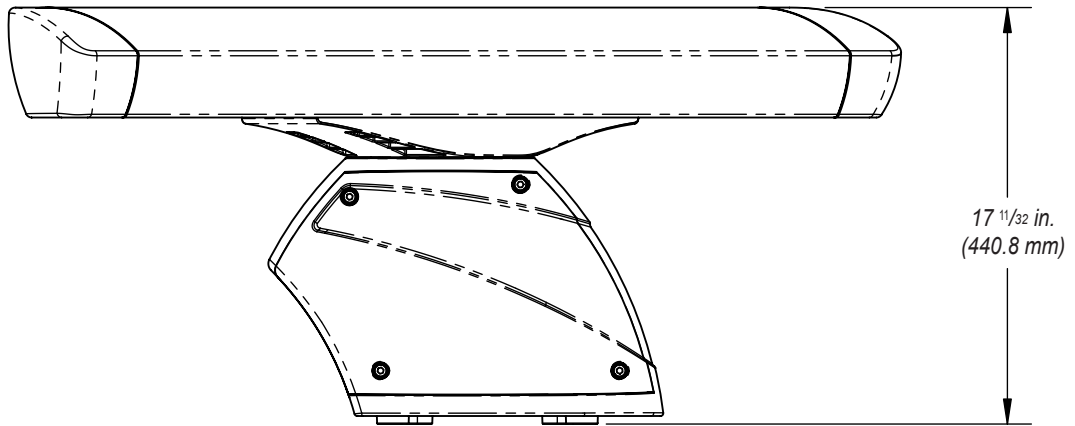

Model	L
GMR 604/1204	51 ¹⁹ / ₃₂ in. (1310 mm)
GMR 606/1206	75 ⁴⁵ / ₆₄ in. (1923 mm)

Specifications

Pedestal (Physical)

Weight: 42 lb. (19 kg)

Power Cable: 49 ft. 2 ³⁵/₆₄ in. (15 m) long

Network Cable: 49 ft. 2 ³⁵/₆₄ in. (15 m) long

600 Series

Transmit Power: 6 kW

Transmitter Frequency: 9410 ±30 MHz

Input Voltage: 10–40 Vdc (with the Voltage Converter Unit)

Typical Input Power: 55 W

Input Power (100 kn wind):
145 W max

Range/Pulse Width/PRF (nm/nsec/Hz):

0.125 – 0.5/75/3980

0.750 - 1/185/3975

1.5/235/3200

2.0/283/2750

3.0/370/1970

4.0/440/1736

6.0 – 12/535/1407

16 – 36/1032/800

48 – 72/1032/500

Antenna Rotation: 24 rpm and 48 rpm

Max wind load: 100 kts

Receiver Noise Figure: Less than 4 dB

Environmental:

Temp: from 14 to 140°F
(from -10 to +60°C)

Humidity: 95% at 95 °F (35 °C)

Rel Wind: 100 kn

Waterproof to IEC 60529 IPX6

Range: 65.5 ft. (20 m) mini, 72 nm max

Range discrimination: 65.5 ft. (20 m)

Radar interference: Anti-jamming algorithm

Clutter suppression: Sea clutter and rain clutter

1200 Series

Transmit Power: 12 kW

Transmitter Frequency: 9410 ±30 MHz

Input Voltage: 20–40 Vdc (with the Voltage Converter Unit)

Typical Input Power: 65 W

Input Power (100 kn wind):
155 W max

Range/Pulse Width/PRF (nm/nsec/Hz):

0.125 – 0.5/75/3980

0.750 - 1/185/3975

1.5/235/3200

2.0/283/2750

3.0/370/1970

4.0/440/1736

6.0 – 12/535/1407

16 – 36/1032/800

48 – 72/1032/500

Antenna Rotation: 24 rpm and 48 rpm

Max wind load: 100 kts

Receiver Noise Figure: Less than 4 dB

Environmental:

Temp: from 14 to 140°F
(from -10 to +60°C)

Humidity: 95% at 95 °F (35 °C)

Rel Wind: 100 kn

Waterproof to IEC 60529 IPX6

Range: 65.5 ft. (20 m) min, 72 nm max

Range discrimination: 65.5 ft. (20 m)

Radar interference: Anti-jamming algorithm

Clutter suppression: Sea clutter and rain clutter

4 ft Open-Array Antenna

Type: End-fed slotted waveguide

Horizontal Beamwidth: 1.8 degrees

Horizontal Sidelobes:

-23 dB within ±10 degrees of main

-30 dB outside ±10 degrees of main

Vertical Beamwidth: 24 degrees

Antenna Gain: 29 dB

Polarization: Horizontal

Input Return Loss: Better than -20 dB

Weight: 12 lb. (5.4 kg)

6 ft. Open-Array Antenna

Type: End-fed slotted waveguide

Horizontal Beamwidth: 1.1 degrees

Horizontal Sidelobes:

-25 dB within ±10 degrees of main

-30 dB outside ±10 degrees of main

Vertical Beamwidth: 24 degrees

Antenna Gain: 30 dB

Polarization: Horizontal

Input Return Loss: Better than -20 dB

Weight: 16 lb. (7.3 kg)

Radar Display Features

Presentation Modes: North up, Course up, Heading up

VRM/EBL: 1 user adjustable (GPSMAP 4000/5000 series chartplotters)

2 user adjustable, capable of floating (GPSMAP 3000 series chartplotters)

Bearing Accuracy: 1 degree

Range Ring Accuracy: 65.5 ft. (20 m) or ±1.5% of range scale, whichever is greater

Controls: Auto & manual gain adjust; manual or auto (AFC) receiver tuning;

manual adjust for rain clutter and for sea clutter.

Radar/Chart Overlay: Overlay mode is supported. Also has split overlay with standard radar presentation

Harbor Mode: Optimized radar performance in the harbor

Offshore Mode: Optimized radar performance offshore

Dual Range Mode: Simultaneous operation of two ranges displayed in split screen format
User selectable ranges of 1/8 nm to 3 nm on left side and 1/8 nm to 72 nm on right side

Timed Transmit: (GPSMAP 3000 series chartplotters) user-specified transmission and standby time.

Sentry: (GPSMAP 4000/5000 series chartplotters) user-adjustable timed-transmit mode

Zoom Mode: 2x, 4x (GPSMAP 3000 series chartplotters only)

Trails (Wakes): Short, Medium, Long (GPSMAP 3000 series chartplotters only)

Guard Zone Alarm: 2 guard zones—user adjustable

Off center Function: Look ahead (GPSMAP 4000/5000 series chartplotters)
Look ahead, Auto Shift and Manual (GPSMAP 3000 series chartplotters)

Antenna RPM: Selectable to 24 or 48 rpm

MARPA: Tracks up to 10 MARPA targets for radar plotting and collision avoidance (Heading sensor is required)

All rights reserved. Except as expressly provided herein, no part of this manual may be reproduced, copied, transmitted, disseminated, downloaded or stored in any storage medium, for any purpose without the express prior written consent of Garmin. Garmin hereby grants permission to download a single copy of this manual onto a hard drive or other electronic storage medium to be viewed and to print one copy of this manual or of any revision hereto, provided that such electronic or printed copy of this manual must contain the complete text of this copyright notice and provided further that any unauthorized commercial distribution of this manual or any revision hereto is strictly prohibited.

Information in this document is subject to change without notice. Garmin reserves the right to change or improve its products and to make changes in the content without obligation to notify any person or organization of such changes or improvements. Visit the Garmin Web site (www.garmin.com) for current updates and supplemental information concerning the use and operation of this and other Garmin products.

Garmin®, the Garmin logo, and GPSMAP® are trademarks of Garmin Ltd. or its subsidiaries, registered in the USA and other countries. GMR™ and myGarmin™ are trademarks of Garmin Ltd. or its subsidiaries. These trademarks may not be used without the express permission of Garmin.

Furuno® is a registered trademark of Furuno Electric Co., Ltd. Raymarine® is a registered trademark of Raymarine Limited.

**For the latest free software updates (excluding map data) throughout the life of your
Garmin products, visit the Garmin Web site at www.garmin.com.**



© 2009 Garmin Ltd. or its subsidiaries

Garmin International, Inc.
1200 East 151st Street, Olathe, Kansas 66062, USA

Garmin (Europe) Ltd.
Liberty House, Hounslow Business Park, Southampton, Hampshire, SO40 9LR UK

Garmin Corporation
No. 68, Jangshu 2nd Road, Shijr, Taipei County, Taiwan

www.garmin.com