

**APPLICATION**  
For  
**GRANT OF**  
**CERTIFICATION**

FOR

**MODEL:**

**011-01326-0X**

**Low Power Transmitter**

**P/N 011-01326-0x**

FCC ID: IPH-01017

IC: 1792A-01017

FOR

**GARMIN INTERNATIONAL, INC.**

1200 East 151st Street

Olathe, KS 66062

Test Report number 060208



# ROGERS LABS, INC.

4405 West 259<sup>th</sup> Terrace  
Louisburg, KS 66053  
Phone / Fax (913) 837-3214

## TEST REPORT

For

## APPLICATION of CERTIFICATION

For

## GARMIN INTERNATIONAL, INC.

1200 East 151st Street  
Olathe, KS 66062  
Phone: (913) 397-8200

Mr. Van Ruggles  
Director of Quality Assurance

MODEL: 011-01326-0X  
GPN 011-01326-0x

Low Power Transmitter  
FREQUENCY: 2,400-2,483.5 MHz

FCC ID: IPH-01017  
IC: 1792A-01017

Test Report Number: 060208

Test Date: February 8, 2006

Certifying Engineer: *Scot D. Rogers*  
Scot D. Rogers  
ROGERS LABS, INC.  
4405 West 259th Terrace  
Louisburg, KS 66053  
Telephone: (913) 837-3214  
FAX: (913) 837-3214

This report shall not be reproduced except in full, without the written approval of the laboratory. This report must not be used by the client to claim product endorsement by NVLAP or any agency of the U.S. Government.

**TABLE OF CONTENTS**

**TABLE OF CONTENTS** 3

**FORWARD** 4

**APPLICABLE STANDARDS & TEST PROCEDURES** 4

**EQUIPMENT TESTED** 5

**LIST OF TEST EQUIPMENT** 5

**2.1033(B) APPLICATION FOR CERTIFICATION** 6

**EQUIPMENT AND CABLE CONFIGURATION** 7

    Test Setup 7

**EQUIPMENT FUNCTION AND TESTING PROCEDURES** 7

    Configuration options for the EUT 8

    AC Line Conducted Emission Test Procedure 9

    Radiated Emission Test Procedure 9

    Units of Measurements 9

    Test Site Locations 10

**SUBPART C - INTENTIONAL RADIATORS** 10

**15.203 ANTENNA REQUIREMENTS** 10

**15.205 RESTRICTED BANDS OF OPERATION** 11

    Data 15.205 12

    Summary of Results for Radiated Emissions in Restricted Bands 15.205 12

**15.207 CONDUCTED EMISSIONS LIMITS; GENERAL REQUIREMENTS** 12

    AC Line Conducted EMI 15.207 12

    Data Conducted Emissions (7 Highest Emissions) (320-00171-12) 18

    Data Conducted Emissions (7 Highest Emissions) (320-00171-11) 18

    Data Conducted Emissions (7 Highest Emissions) (320-00171-13) 18

    Data Conducted Emissions (7 Highest Emissions) (320-00171-14) 19

    Summary of Results for AC Line Conducted General Emissions 15.207 19

**15.209 RADIATED EMISSIONS LIMITS; GENERAL REQUIREMENTS** 19

    General Radiated EMI 15.209 19

    General Radiated Emissions Data 15.209 23

    Summary of Results for General Radiated Emissions 15.209 23

**15.249 OPERATION IN THE BAND 2,400-2,483.5 MHZ** 24

    Transmitter Radiated Emissions 29

    Power from Antenna Substitution Method for 15.249 30

    Transmitter Antenna Conducted Emissions 30

**TRANSMITTER EMISSIONS SUMMARY OF RESULTS** 30

    Summary of Results for Transmitter Radiated Emissions 15.249 30

**FREQUENCY STABILITY** 31

    Measurements Required 31

    Test Arrangement 31

    Results 32

    Summary of Results for Frequency Stability 33

    Statement of Modifications and Deviations 33

**APPENDIX** 34

## FORWARD

The following information is submitted for consideration in obtaining a Grant of Certification for low power intentional radiator per CFR Paragraph 15.249 operation in the 2400 - 2483.5 MHz band.

Name of Applicant: Garmin International, Inc.  
1200 East 151st Street  
Olathe, KS 66062

Model: 011-01326-0x, GPN 011-01326-0x

FCC ID: IPH-01017

Industry Canada ID: 1792A-01017

Frequency Range: 2400-2483.5 MHz.

Operating Power: Less than 1 mW (as design specification,  
measured 94.9 dB $\mu$ V/m @ 3 meters).

## Applicable Standards & Test Procedures

- a) In accordance with the Federal Communications Code of Federal Regulations, dated October 1, 2004, Part 2, Subpart J, Paragraphs 2.907, 2.911, 2.913, 2.925, 2.926, 2.1031 through 2.1057, applicable parts of paragraph 15, Part 15C paragraph 15.249, and Industry Canada RSS-210, the following information is submitted.
- b) Test procedures used are the established Methods of Measurement of Radio-Noise Emissions as described in the ANSI 63.4-2003 Document, and FCC documents DA00-1407 and DA00-705.

### Equipment Tested

<u>Equipment</u>	<u>Serial Number</u>	<u>FCC I.D.#</u>
011-01326-0X	ENG 1	IPH-01017
GA 27	GA27-1	N/A
GXM 30	YHZHEOWL	N/A
GTM 10	GTM10-1	N/A
Dell Computer	2574199639	DoC
Printer	B94C2121X	N/A

### List of Test Equipment

A Hewlett Packard 8591EM and or 8562A Spectrum Analyzer was used as the measuring device for the emissions testing. The analyzer settings used are described in the following table. Refer to the Appendix for a complete list of Test Equipment.

<b>HP 8591EM SPECTRUM ANALYZER SETTINGS</b>		
CONDUCTED EMISSIONS:		
RBW	AVG. BW	DETECTOR FUNCTION
9 kHz	30 kHz	Peak/Quasi Peak
RADIATED EMISSIONS (30 - 1000 MHz):		
RBW	AVG. BW	DETECTOR FUNCTION
120 kHz	300 kHz	Peak/Quasi Peak
<b>HP 8562A SPECTRUM ANALYZER SETTINGS</b>		
RADIATED EMISSIONS (1 - 40 GHz):		
RBW	AVG. BW	DETECTOR FUNCTION
1 MHz	1 MHz	Peak/Average
ANTENNA CONDUCTED EMISSIONS:		
RBW	AVG. BW	DETECTOR FUNCTION
120 kHz	300 kHz	Peak

<u>EQUIPMENT</u>	<u>MFG.</u>	<u>MODEL</u>	<u>CAL. DATE</u>	<u>DUE.</u>
LISN	Comp. Design	FCC-LISN-2-MOD.CD	10/05	10/06
LISN	FCC	FCC-LISN-50-16-2-08	6/05	6/06
LISN	Comp. Design	1762	2/05	2/06
Antenna	ARA	BCD-235-B	10/05	10/06
Antenna	EMCO	3147	10/05	10/06
Antenna	EMCO	3143	5/05	5/06
Analyzer	HP	8591EM	5/05	5/06
Analyzer	HP	8562A	2/05	2/06

## 2.1033(b) Application for Certification

- (1) Manufacturer: GARMIN INTERNATIONAL, INC.  
1200 East 151st Street  
Olathe, KS 66062  
Telephone: (913) 397-8200
- (2) FCC Identification: FCC I.D.: IPH-01017
- (3) Copy of the installation and operating manual: Refer to exhibit for Draft Instruction Manual.
- (4) Description of Circuit Functions, Device Operation: The 011-01326-0X is a low power Transmitter.
- (5) Block Diagram with Frequencies: Refer to exhibit for the Block Diagram
- (6) Report of measurements showing compliance with the pertinent FCC technical requires are provided in this report.
- (7) Photographs of equipment are provided in this report and exhibits.
- (8) Peripheral equipment or accessories for the equipment. Optional equipment available for the EUT include, AC and DC power adapter, external GPS antenna, GXM 30, GTM 10, and USB cable for computer interface. The available configuration options were investigated for this report with worst-case data presented.
- (9) Transition Provisions of 15.37 are not being requested.
- (10) The equipment is not a scanning receiver.
- (11) The equipment is not a transmitter operating in the 59-64 GHz frequency range.

## Equipment and Cable Configuration

### **Test Setup**

The 011-01326-0X is a GPS receiver used for location and navigation and incorporates a low power transmitter operating under the Blue Tooth design specification allowing short-range communications. The GPS receiver is used to display location and navigation. The unit was designed to be mounted in an automotive application and the transmitter section allows for short-range communications to other Blue Tooth devices. The EUT was arranged in typical user equipment configurations for testing purposes. The transmitter offers no interface connection and powered from either an A/C or D/C power adapter. As requested by the manufacturer and required by the CFR, the unit was tested for emissions compliance using the available configurations with the worst-case data presented. Test results in this report relate only to the products described in this report.

### **Equipment Function and Testing Procedures**

The EUT is a low power transmitter operating in the 2400-2483.5 MHz frequency band. The unit allows communications to other Blue Tooth enabled devices.

**Configuration options for the EUT**

- 011-01326-0X connected to USB cable (GPN: 325-00128-01) and PC. Powered by AC wall adapter (GPN: 320-00171-12) or cigarette lighter adapter/talkbox (GPN: 011-01241-00). 2.5mm and 3.5mm jacks available for audio input/output. Can be used with external antenna (GPN: 011-00149-05). Can be connected to a Bluetooth wireless accessory e.g. Bluetooth cellular phone (not sold by Garmin).

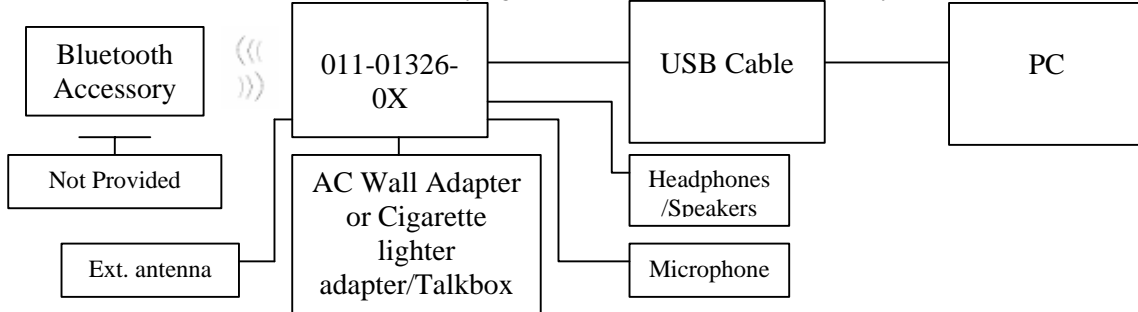

- 011-01326-0X connected to GXM30 XM receiver (GPN: 011-01316-00) or GTM 10 TMC FM traffic receiver (GPN: 011-01150-0x). Powered by AC wall adapter (GPN: 320-00171-12) or cigarette lighter adapter/talkbox (GPN: 011-01241-00). 2.5mm and 3.5mm jacks available for audio input/output. Can be used with external antenna (GPN: 011-00149-05). Can be connected to a Bluetooth wireless accessory e.g. Bluetooth cellular phone (not sold by Garmin).

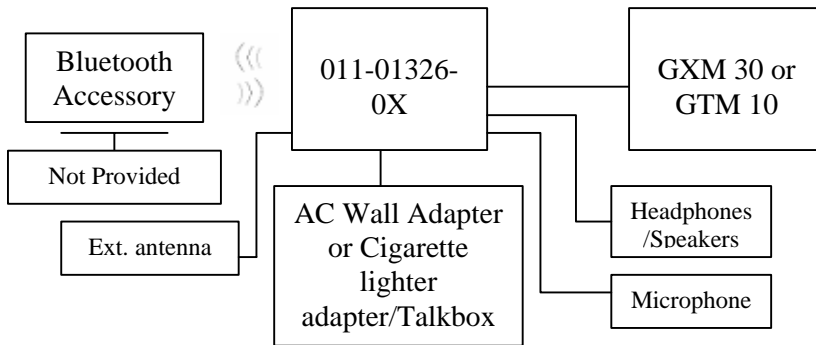

- 011-01326-0X connected to GTM 10 TMC FM traffic receiver (GPN: 011-01150-0x). Powered by AC wall adapter (GPN: 320-00171-12), cigarette lighter adapter/talkbox (GPN: 011-01241-00), or cradle cigarette lighter adapter (GPN: 320-00171-51). 2.5mm jack available for audio output. Can be used with external antenna (GPN: 011-00149-05). Can be connected to a Bluetooth wireless accessory e.g. Bluetooth cellular phone (not sold by Garmin).

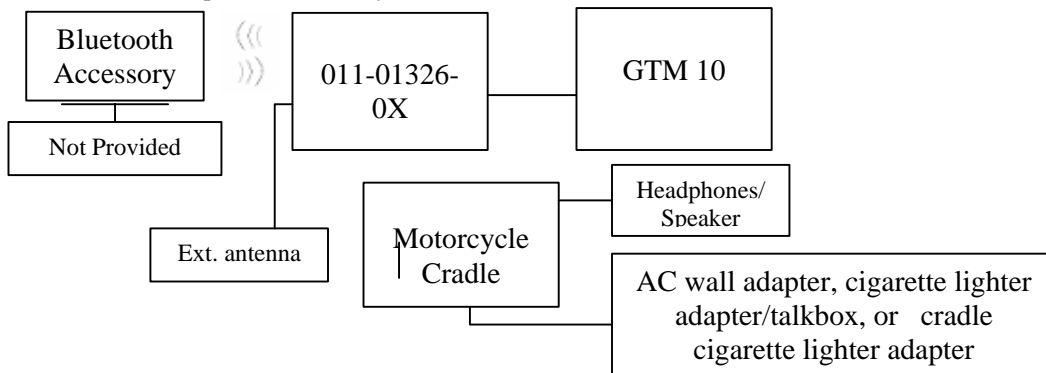

Notes:

- Input voltage of the AC Wall adapter (GPN: 320-00171-12) is 100-240 VAC, 47-63 Hz.
- Output voltage of the AC Wall adapter (GPN: 320-00171-12) is 12VDC.
- Internal clock oscillator frequencies of the 011-01326-0X are 32.768 kHz , 7.37 MHz, 12.0 MHz, 16.367673 MHz, 26 MHz, and 45.158 MHz.

Bluetooth transmits in the 2.45 GHz band (FHSS).



**AC Line Conducted Emission Test Procedure**

The test setup, including the EUT, was arranged in a test equipment configuration and placed on a 1 x 1.5-meter wooden bench, 0.8 meters high located in a screen room. The power lines of the system were isolated from the power source using a standard LISN with a 50- $\mu$ Hy choke. EMI was coupled to the spectrum analyzer through a 0.1  $\mu$ F capacitor internal to the LISN. The LISN was positioned on the floor beneath the wooden bench supporting the EUT. The power lines and cables were draped over the back edge of the table.

**Radiated Emission Test Procedure**

The EUT was placed on a rotating 1 x 1.5-meter wooden platform 0.8 meters above the ground plane at a distance of 3 meters from the FSM antenna. EMI energy was maximized by equipment placement, raising and lowering the FSM antenna, changing the antenna polarization, and by rotating the turntable. Each emission was maximized before data was taken using a spectrum analyzer. Refer to photographs in exhibits for EUT placement used during testing.

**Units of Measurements**

Conducted EMI: Data is in dB $\mu$ V; dB referenced to one microvolt.

Radiated EMI: Data is in dB $\mu$ V/m; dB/m referenced to one microvolt per meter.

**Test Site Locations**

Conducted EMI: ROGERS LABS, INC. located at 4405 W. 259<sup>th</sup>  
Terrace, Louisburg, KS.

Radiated EMI: The radiated emissions tests were performed at  
Rogers Labs, Inc. 3 meters Open Area Test Site  
(OATS) located at 4405 W. 259th Terrace,  
Louisburg, KS.

Site Approval: Refer to Appendix for FCC Site Approval Letter,  
Reference 90910, And Dated August 15, 2003,  
Industry Canada reference IC 3041 dated August 30,  
2003.

**Subpart C - Intentional Radiators**

As per CFR Part 15, Subpart C the following information is  
submitted for consideration in obtaining a grant of certification  
for unlicensed intentional radiators.

**15.203 Antenna Requirements**

The unit is produced with a permanently attached antenna inside  
the sealed plastic case. No provisions for modification or  
alterations of the antenna configuration are available to the end  
user. For testing purposes, a test unit was modified to allow  
for antenna-conducted emissions testing for this and other  
compliance standards. The requirements of 15.203 are met there  
are no deviations or exceptions to the specification.

### 15.205 Restricted Bands of Operation

Spurious emissions falling in the restricted frequency bands of operation were measured at the OATS. The EUT utilizes frequency, determining circuitry, which generates harmonics falling in the restricted bands. Emissions were checked at the OATS, using appropriate antennas or pyramidal horns, amplification stages, and a spectrum analyzer. Peak and average amplitudes of frequencies above 1000 MHz were compared to the required limits with worst-case data presented below. No other significant emission was observed which fell into the restricted bands of operation. Computed emission values take into account the measured radiated field strength, receive antenna correction factor, amplifier gain stage, and test system cable losses.

#### Sample Calculations:

$$\begin{aligned}\text{Computed Peak (dB}\mu\text{V/m @ 3m)} &= \text{FSM (dB}\mu\text{V)} + \text{A.F. (dB)} - \text{Gain (dB)} \\ &= 52.3 + 7.0 - 30 \\ &= 29.3\end{aligned}$$

**Data 15.205**

Radiated Emissions in restricted bands

Emission Frequency (MHz)	FSM Horz. (dBµV)	FSM Vert. (dBµV)	Ant. Factor (dB)	Amp. Gain (dB)	RFS Horz. @ 3m (dBµV/m)	RFS Vert. @ 3m (dBµV/m)	Limit @ 3m (dBµV/m)
121.0	52.3	53.9	7.0	30	29.3	30.9	43.5
125.9	47.1	50.2	7.6	30	24.7	27.8	43.5
133.5	43.6	45.1	8.4	30	22.0	23.5	43.5
168.0	41.8	47.1	8.7	30	20.5	25.8	43.5
322.5	46.1	47.5	14.8	30	30.9	32.3	46.0
4804.0	26.0	25.0	32.9	30	28.9	27.9	54.0
4882.0	24.5	24.5	32.9	30	27.4	27.4	54.0
4960.0	23.8	24.3	32.9	30	26.7	27.2	54.0
7323.0	26.2	27.3	36.3	30	32.5	33.6	54.0
7440.0	26.5	27.2	36.5	30	33.0	33.7	54.0
12010.0	27.0	27.3	40.0	30	37.0	37.3	54.0
12205.0	26.8	27.1	40.4	30	37.2	37.5	54.0
12400.0	26.8	27.0	40.8	30	37.6	37.8	54.0

No other emissions found in the restricted bands.

**Summary of Results for Radiated Emissions in Restricted Bands 15.205**

The radiated emissions for the EUT meet the requirements for FCC CFR 47 Part 15.205 restricted bands of operation. The EUT had a 12.6 dB minimum margin below the limits. Other emissions were present with amplitudes at least 20 dB below the FCC Limits.

**15.207 Conducted emissions limits; general requirements**

**AC Line Conducted EMI 15.207**

The EUT was arranged in a typical equipment configuration (configurations 1 and 2). Testing was performed with the EUT placed on a 1 x 1.5-meter wooden bench 80 cm above the conducting ground plane, floor of a screen room. The bench was positioned 40 cm away from the wall of the screen room. The LISN was positioned on the floor of the screen room 80-cm from the rear of the EUT. Testing for the line-conducted emissions was as follows. The ac adapter for

the EUT was connected to the LISN for line-conducted emissions testing. A second LISN was positioned on the floor of the screen room 80-cm from the rear of the supporting equipment of the EUT. All power cords except the EUT were then powered from the second LISN. EMI was coupled to the spectrum analyzer through a 0.1  $\mu$ F capacitor, internal to the LISN. Power line conducted emissions testing was carried out individually for each current carrying conductor of the EUT. The excess length of lead between the system and the LISN receptacle was folded back and forth to form a bundle not exceeding 40 cm in length. The screen room, conducting ground plane, analyzer, and LISN were bonded together to the protective earth ground. Preliminary testing was performed to identify the frequencies of each of the emissions, which had the highest amplitudes. The cables were repositioned to obtain maximum amplitude of measured EMI level. Once the worst-case configuration was identified, plots were made of the EMI from 0.15 MHz to 30 MHz then the data was recorded with maximum conducted emissions levels.

Refer to Figures 1 and 2 for plots of the EUT (320-00171-12) conducted emissions frequency spectrum taken in the screen room. Refer to Figures 3 and 4 for plots of the EUT (320-00171-11) conducted emissions frequency spectrum taken in the screen room. Refer to Figures 5 and 6 for plots of the EUT (320-00171-13) conducted emissions frequency spectrum taken in the screen room. Refer to Figures 7 and 8 for plots of the EUT (320-00171-14) conducted emissions frequency spectrum taken in the screen room.

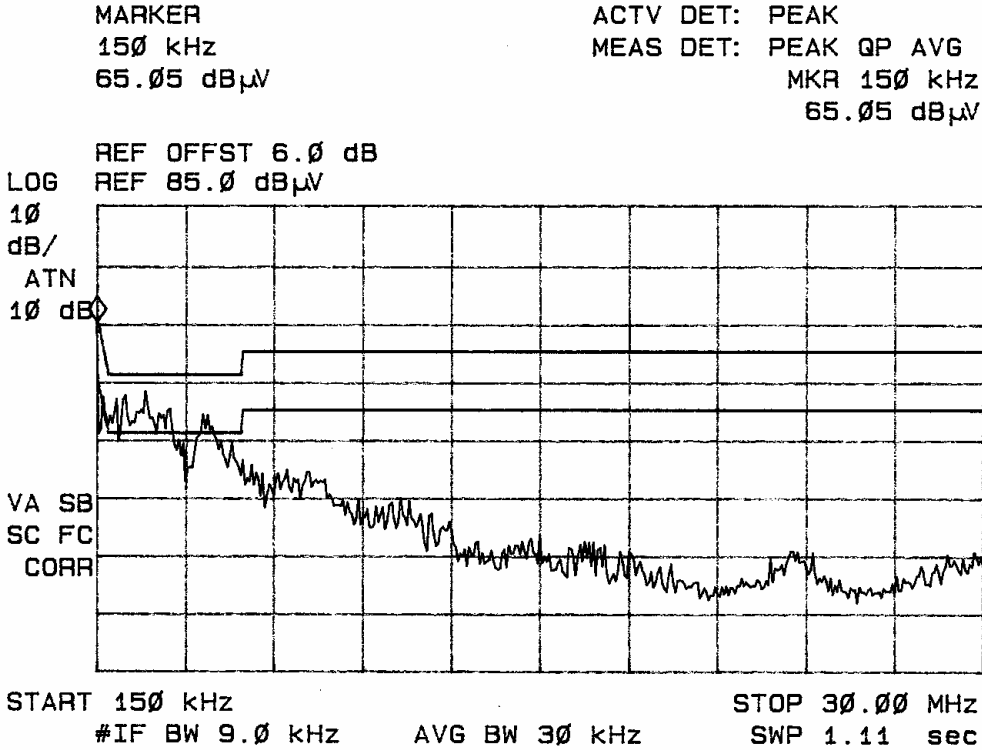

Figure one Conducted emissions of EUT line 1 (320-00171-12)

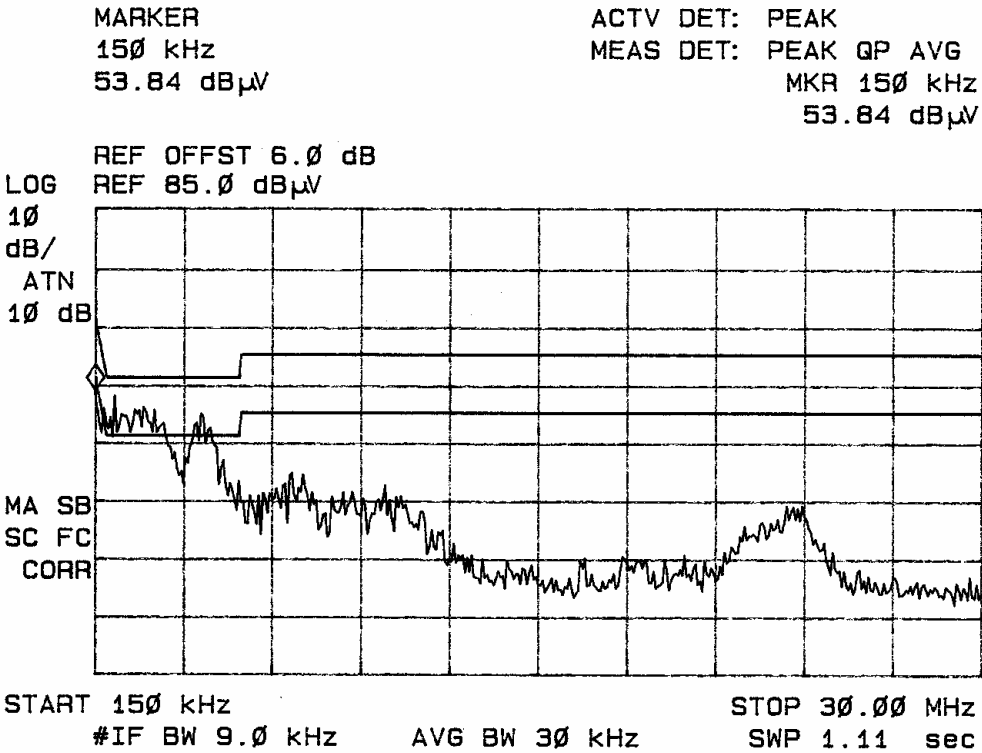

Figure two Conducted emissions of EUT line 2 (320-00171-12)

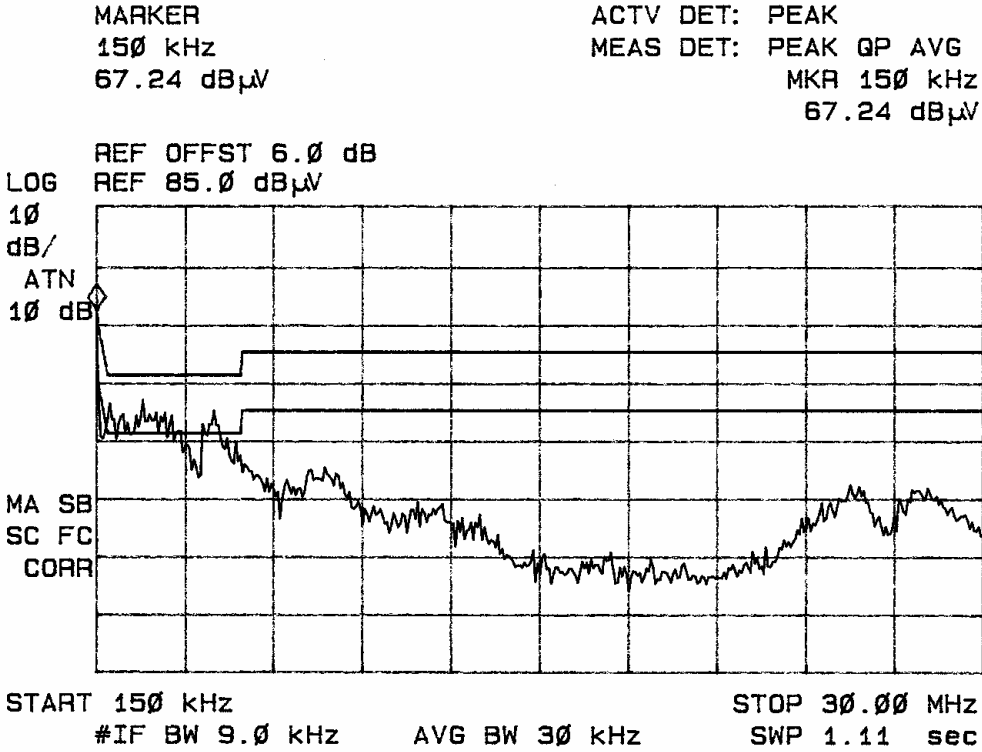

Figure three Conducted emissions of EUT line 1 (320-00171-11)

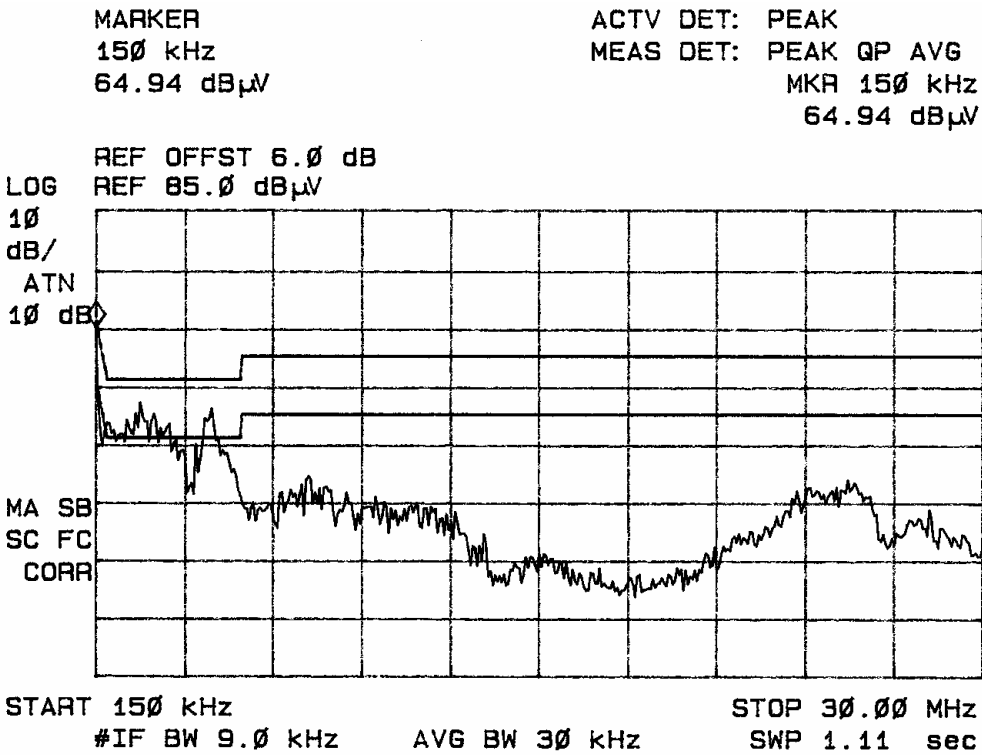

Figure four Conducted emissions of EUT line 2 (320-00171-11)

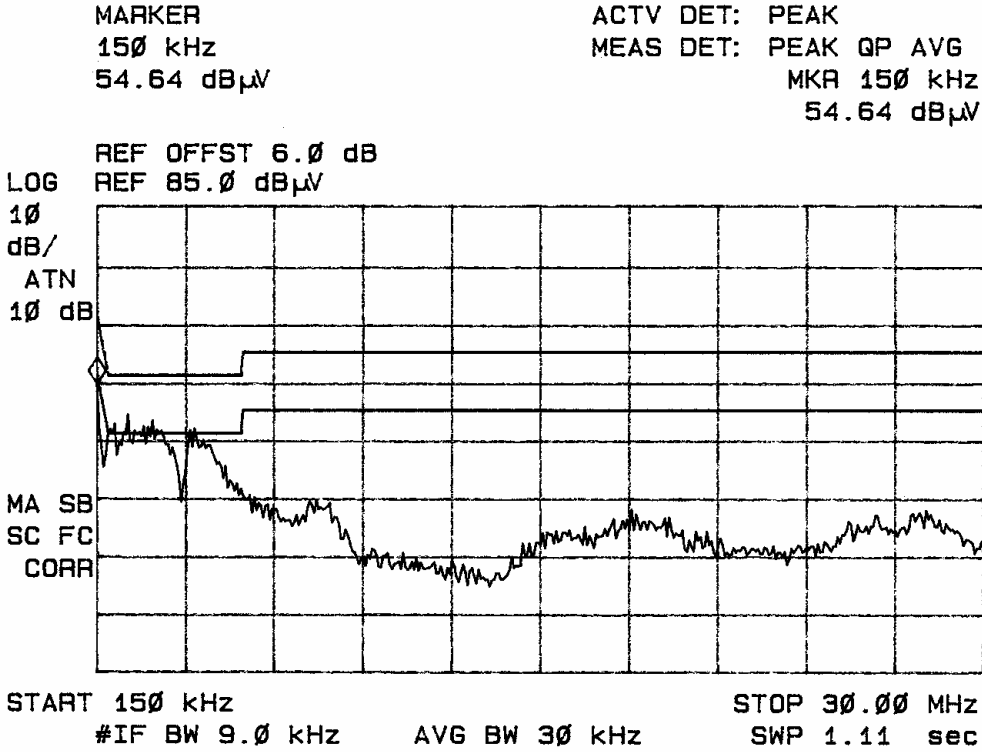

Figure five Conducted emissions of EUT line 1 (320-00171-13)

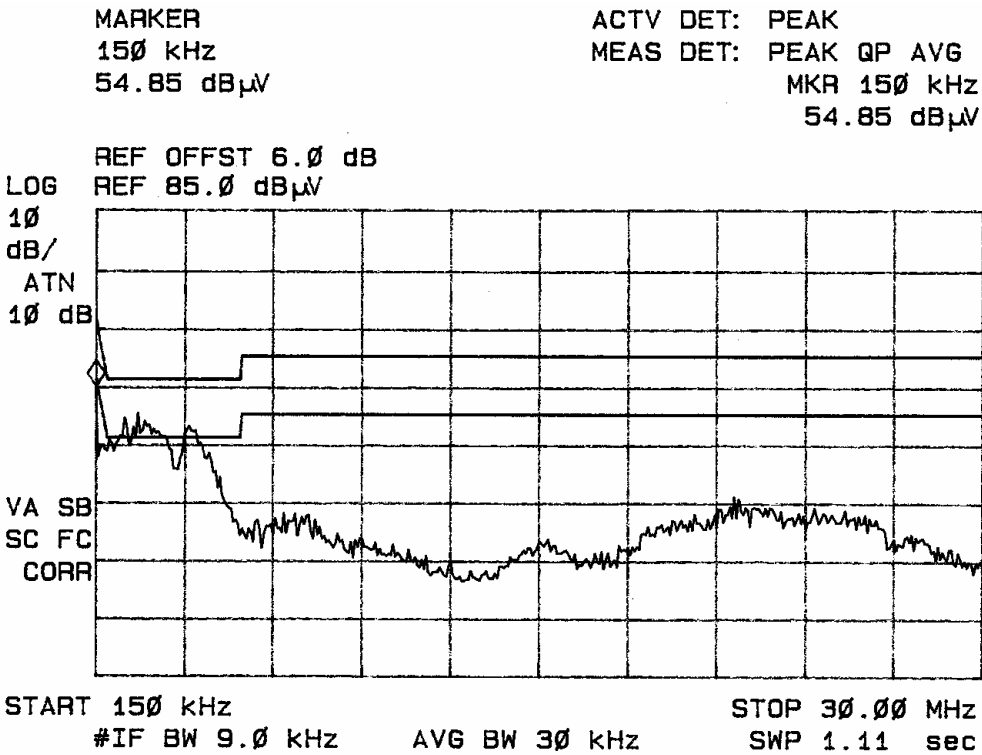

Figure Six Conducted emissions of EUT line 2 (320-00171-13)



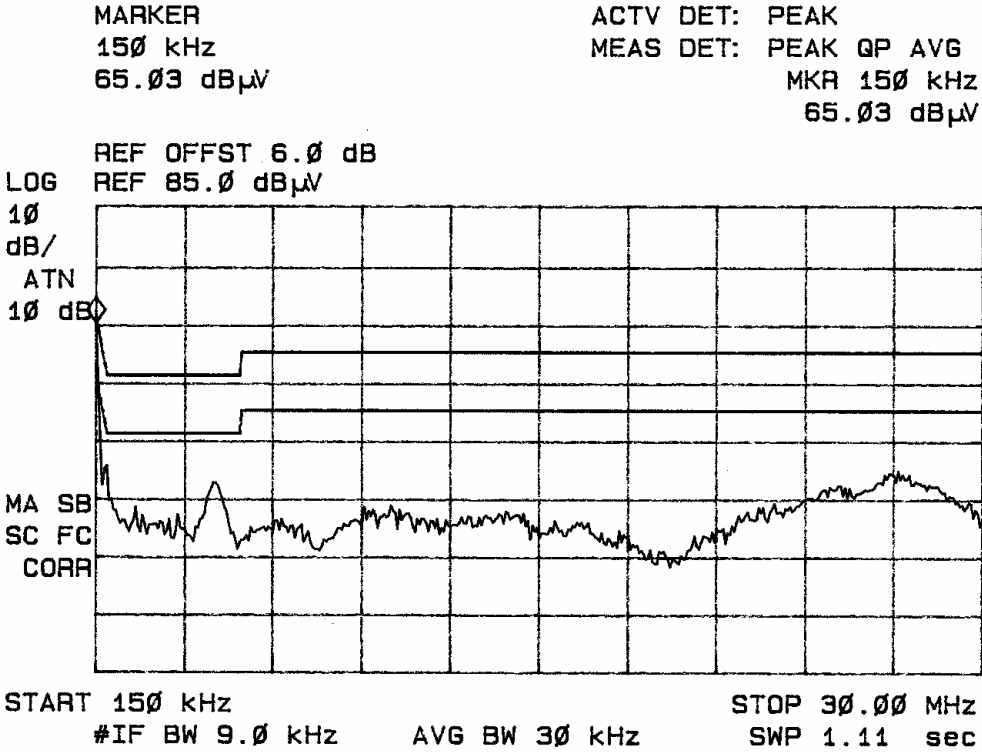

Figure seven Conducted emissions of EUT line 1 (320-00171-14)

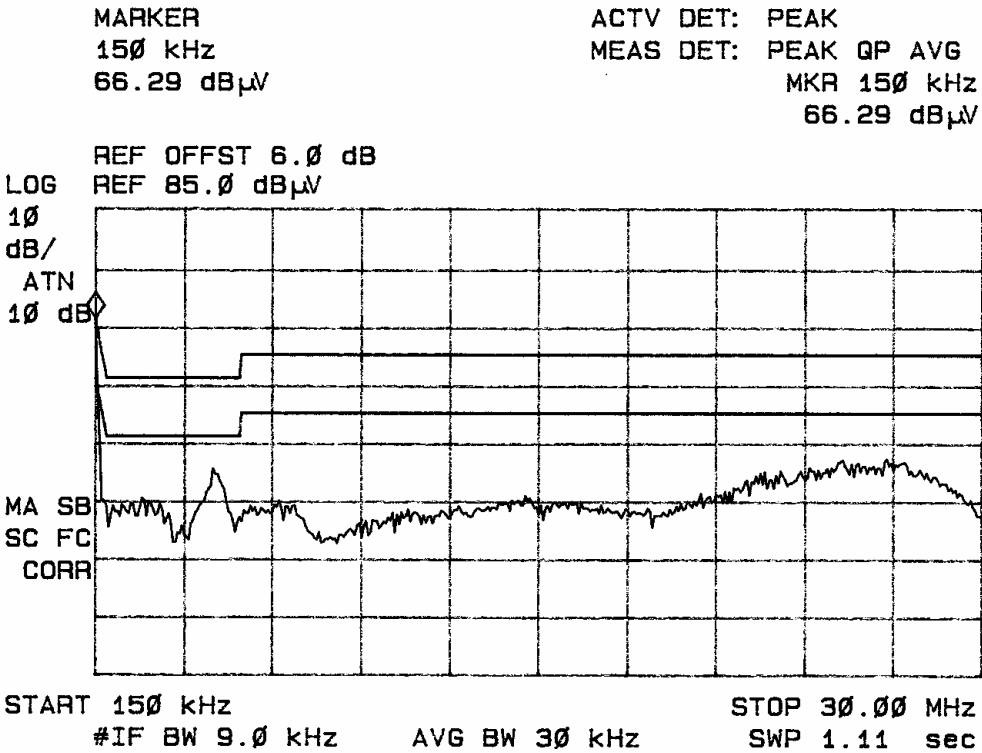

Figure eight Conducted emissions of EUT line 2 (320-00171-14)

**Data Conducted Emissions (7 Highest Emissions) (320-00171-12)**

Frequency band (MHz)	L1 Level (dBµV)			L2 Level (dBµV)			CISPR 22 Limit Q.P. Ave(dBµV)
	Peak	Q.P.	AVE	Peak	Q.P.	AVE	
0.15 - 0.5	65.1	48.9	22.0	54.0	49.4	26.0	66-56 / 56-46
0.5 - 5	53.4	46.5	22.7	54.1	47.5	28.5	56 / 46
5 - 10	39.2	32.8	20.2	39.5	33.0	16.8	60 / 50
10 - 15	33.2	26.6	14.7	36.1	27.1	14.8	60 / 50
15 - 20	28.5	19.9	11.3	26.0	18.9	10.7	60 / 50
20 - 25	25.8	19.9	11.3	36.5	29.2	18.3	60 / 50
25 - 30	25.3	19.1	11.3	25.0	18.7	10.7	60 / 50

Other emissions present had amplitudes at least 20 dB below the limit.

**Data Conducted Emissions (7 Highest Emissions) (320-00171-11)**

Frequency band (MHz)	L1 Level (dBµV)			L2 Level (dBµV)			CISPR 22 Limit Q.P. Ave(dBµV)
	Peak	Q.P.	AVE	Peak	Q.P.	AVE	
0.15 - 0.5	67.2	56.4	37.6	35.0	57.0	37.7	66-56 / 56-46
0.5 - 5	50.9	45.3	33.2	51.8	45.1	33.1	56 / 46
5 - 10	42.0	35.3	21.6	37.9	29.9	16.9	60 / 50
10 - 15	32.9	25.3	13.9	35.0	27.7	15.7	60 / 50
15 - 20	25.7	17.7	10.4	26.7	19.9	11.7	60 / 50
20 - 25	34.8	28.4	19.3	39.2	32.3	23.1	60 / 50
25 - 30	36.6	29.0	21.0	40.8	33.2	23.2	60 / 50

Other emissions present had amplitudes at least 20 dB below the limit.

**Data Conducted Emissions (7 Highest Emissions) (320-00171-13)**

Frequency band (MHz)	L1 Level (dBµV)			L2 Level (dBµV)			CISPR 22 Limit Q.P. Ave(dBµV)
	Peak	Q.P.	AVE	Peak	Q.P.	AVE	
0.15 - 0.5	54.6	50.8	32.6	54.8	50.8	31.6	66-56 / 56-46
0.5 - 5	50.0	45.0	28.9	50.6	44.6	29.0	56 / 46
5 - 10	35.2	29.9	17.4	31.1	25.1	13.4	60 / 50
10 - 15	27.7	19.4	11.0	24.7	19.1	10.2	60 / 50
15 - 20	22.6	17.3	10.6	25.5	19.2	12.0	60 / 50
20 - 25	29.5	23.5	15.9	32.8	26.6	18.5	60 / 50
25 - 30	32.6	25.9	17.9	32.2	26.6	18.8	60 / 50

Other emissions present had amplitudes at least 20 dB below the limit.

**Data Conducted Emissions (7 Highest Emissions) (320-00171-14)**

Frequency band (MHz)	L1 Level (dBµV)			L2 Level (dBµV)			CISPR 22 Limit Q.P. Ave(dBµV)
	Peak	Q.P.	AVE	Peak	Q.P.	AVE	
0.15 - 0.5	65.0	55.2	46.0	66.3	54.2	42.4	66-56 / 56-46
0.5 - 5	42.1	40.4	36.7	41.0	39.4	33.6	56 / 46
5 - 10	32.8	30.4	21.9	34.5	32.2	25.7	60 / 50
10 - 15	32.8	29.6	19.7	35.2	32.2	22.7	60 / 50
15 - 20	31.6	27.8	18.2	34.6	31.9	22.1	60 / 50
20 - 25	37.3	34.0	24.1	41.7	38.0	28.7	60 / 50
25 - 30	38.2	35.4	25.5	40.9	38.4	28.5	60 / 50

Other emissions present had amplitudes at least 20 dB below the limit.

**Summary of Results for AC Line Conducted General Emissions 15.207**

The conducted emissions for the EUT meet the requirements for FCC Part 15C Intentional Radiators. The EUT worst-case had an 8.5 dB minimum margin below the FCC/CISPR quasi peak limit, and a 9.3 dB minimum margin below the FCC/CISPR average limit. Other emissions were present with recorded data representing the worst-case amplitudes.

**15.209 Radiated emissions limits; general requirements**

**General Radiated EMI 15.209**

The EUT was arranged in a typical equipment configuration and operated through all of its various modes. Preliminary testing was performed in a screen room with the EUT positioned 1 meter from the FSM. Radiated emissions investigations were performed to identify the frequencies, which produced the highest emissions. Plots were made of the radiated emission frequency spectrum from 30 MHz to 22,000 MHz for the preliminary testing. Refer to figures nine

through twelve showing the radiated emission spectrum displayed on the spectrum analyzer taken in a screen room. The highest radiated emission was then re-maximized at the OATS site before final radiated emissions measurements were performed. Final data was taken with the EUT located at the open field test site at a distance of 3 meters between the EUT and the receiving antenna. The frequency spectrum from 30 MHz to 25,000 MHz was searched for radiated emissions. Peak and average amplitudes of frequencies above 1000 MHz were compared to the required limits with worst-case data presented below. Measured emission levels were maximized by EUT placement on the table, changing cable location, rotating the turntable through 360 degrees, varying the antenna height between 1 and 4 meters above the ground plane and changing antenna polarization between horizontal and vertical. Antennas used were Broadband Biconical from 30 MHz to 200 MHz, Log Periodic from 200 MHz to 5 GHz, and/or Biconilog from 30 MHz to 1000 MHz, Pyramidal Horns from 5 GHz to 25 GHz, and amplification stages.

Sample Calculations:

$$\begin{aligned}
 \text{RFS} &= \text{Radiated Field Strength} \\
 \text{dB}\mu\text{V/m @ 3m} &= \text{dB}\mu\text{V} + \text{A.F.} - \text{Amplifier Gain} \\
 \text{dB}\mu\text{V/m @ 3m} &= 52.3 + 7.0 - 30 \\
 &= 29.3
 \end{aligned}$$





**General Radiated Emissions Data 15.209**

Radiated Emissions per 15.209

Emission Freq. (MHz)	FSM Horz. (dBµV)	FSM Vert. (dBµV)	Ant. Factor (dB)	Amp. Gain (dB)	RFS Horz. @ 3m (dBµV/m)	RFS Vert. @ 3m (dBµV/m)	Limit @ 3m (dBµV/m)
121.0	52.3	53.9	7.0	30	29.3	30.9	43.5
125.9	47.1	50.2	7.6	30	24.7	27.8	43.5
180.0	45.3	51.3	9.1	30	24.4	30.4	43.5
229.5	57.0	52.0	11.4	30	38.4	33.4	46.0
232.5	56.9	54.1	11.4	30	38.3	35.5	46.0
319.5	45.6	47.7	14.8	30	30.4	32.5	46.0
322.5	46.1	47.5	14.8	30	30.9	32.3	46.0
337.5	51.9	53.2	15.2	30	37.1	38.4	46.0
367.5	44.7	44.6	15.4	30	30.1	30.0	46.0
376.5	49.8	52.7	15.6	30	35.4	38.3	46.0
388.5	42.1	46.3	15.9	30	28.0	32.2	46.0

Other emissions were present with amplitudes at least 20 dB below limits.

**Summary of Results for General Radiated Emissions 15.209**

The radiated emissions for the EUT meet the requirements for FCC Part 15C Intentional Radiators. The EUT had a 7.6 dB minimum margin below the limits. Other emissions were present with amplitudes at least 20 dB below the FCC Limits.

### 15.249 Operation in the Band 2,400-2,483.5 MHz

The power output was measured on an open field test site @ 3 meters.

(a) The EUT was placed on a wooden turntable 0.8 meters above the ground plane and at a distance of 3 meters from the FSM antenna. The peak and average amplitude of the carrier frequency was measured using a spectrum analyzer. The peak and average emission amplitude of the emission was then recorded from the analyzer display.

(b) Emissions radiated outside of the specified bands, except for harmonics, shall be attenuated by at least 50 dB below the level of the fundamental or to the general radiated emission limits in 15.209, whichever is the lesser attenuation. Refer to figures thirteen through twenty showing the radiated emission spectrum displayed on the spectrum analyzer of the antenna-conducted emissions taken in a screen room. The amplitudes of each spurious emission were measured both at the OATS at a distance of 3 meters from the FSM antenna and antenna conducted.

The amplitude of each spurious emission was maximized by varying the FSM antenna height, polarization, and by rotating the turntable. A Biconilog Antenna was used for measuring emissions from 30 to 1000 MHz, a Log Periodic Antenna for 200 to 5000 MHz, and Pyramidal Horn Antennas from 4 GHz to 25 GHz. Emissions were measured in dB $\mu$ V/m @ 3 meters.











Sample calculation.

$$\begin{aligned}
 \text{dB}\mu\text{V/m@ 3m} &= \text{FSM} + \text{A.F.} + \text{cable loss} - \text{amplifier Gain} \\
 &= 61.7 + 30.7 + 2.5 - 0 \\
 &= 94.9
 \end{aligned}$$

**Transmitter Radiated Emissions**

Emission Frequency (MHz) (polarization)	FSM Peak (dBμV)	FSM Average (dBμV)	Ant. Factor (dB)	Amp. Gain/Loss (dB)	RFS Peak @ 3m (dBμV/m)	RFS Average @ 3m (dBμV/m)	Limit @ 3m (ave) (dBμV/m)
2402.0 (H)	61.7	31.1	30.7	-2.5	94.9	64.3	95.2
2402.0 (V)	58.7	28.5	30.7	-2.5	91.9	61.7	95.2
4804.0 (H)	36.2	26.0	32.9	30	39.1	28.9	54.0
4804.0 (V)	35.3	25.0	32.9	30	38.2	27.9	54.0
7206.0 (H)	35.3	26.0	36.0	30	41.3	32.0	54.0
7206.0 (V)	37.0	27.5	36.0	30	43.0	33.5	54.0
9608.0 (H)	37.5	27.0	37.2	30	44.7	34.2	54.0
9608.0 (V)	38.0	28.0	37.2	30	45.2	35.2	54.0
12010.0 (H)	37.5	27.0	40.0	30	47.5	37.0	54.0
12010.0 (V)	37.3	27.3	40.0	30	47.3	37.3	54.0
2441.0 (H)	60.7	30.5	31.4	-2.5	94.6	61.0	95.2
2441.0 (V)	57.7	27.5	31.4	-2.5	91.6	58.0	95.2
4882.0 (H)	34.2	24.5	32.9	30	37.1	27.4	54.0
4882.0 (V)	34.2	24.5	32.9	30	37.1	27.4	54.0
7323.0 (H)	36.5	26.2	36.3	30	42.8	32.5	54.0
7323.0 (V)	37.5	27.3	36.3	30	43.8	33.6	54.0
9764.0 (H)	36.5	26.6	38.1	30	44.6	34.7	54.0
9764.0 (V)	36.5	26.8	38.1	30	44.6	34.9	54.0
12205.0 (H)	36.7	26.8	40.4	30	47.1	37.2	54.0
12205.0 (V)	37.6	27.1	40.4	30	48.0	37.5	54.0
2480.0 (H)	57.7	27.7	31.4	-2.5	91.6	58.2	95.2
2480.0 (V)	54.5	24.2	31.4	-2.5	88.4	54.7	95.2
4960.0 (H)	34.0	23.8	32.9	30	36.9	26.7	54.0
4960.0 (V)	35.0	24.3	32.9	30	37.9	27.2	54.0
7440.0 (H)	36.3	26.5	36.5	30	42.8	33.0	54.0
7440.0 (V)	38.0	27.2	36.5	30	44.5	33.7	54.0
9920.0 (H)	35.4	25.5	38.4	30	43.8	33.9	54.0
9920.0 (V)	37.0	26.5	38.4	30	45.4	34.9	54.0
12400.0 (H)	36.9	26.8	40.8	30	47.7	37.6	54.0
12400.0 (V)	38.0	27.0	40.8	30	48.8	37.8	54.0

Note: Levels measured @ 3-meter OATS site.

**Power from Antenna Substitution Method for 15.249**

Frequency of Emission (MHz)	Measured Peak Amplitude of EUT emission		Signal level to substitution antenna required to reproduce	
	Horizontal dBµV	Vertical dBµV	Horizontal dBm	Vertical dBm
2402.0	61.7	58.7	-0.3	-3.3
2441.0	60.7	57.7	-0.6	-3.6
2480.0	57.7	54.5	-3.6	-6.6

**Transmitter Antenna Conducted Emissions**

Frequency (MHz)	Emission level (dBm)
2402.0	-4.3
4804.0	-78.0
7206.0	-80.1
9608.0	-78.2
12010.0	-79.7
2441.0	-3.7
4882.0	-82.6
7323.0	-79.0
9764.0	-78.3
12205.0	-79.8
2480.0	-3.3
4960.0	-77.6
7440.0	-79.2
9920.0	-80.1
12400.0	-79.0

**TRANSMITTER EMISSIONS SUMMARY OF RESULTS**

**Summary of Results for Transmitter Radiated Emissions 15.249**

The EUT had a peak amplitude emission of 0.3 dB margin below the average limit of 15.249. The EUT had an average amplitude of harmonic emissions of 16.2 dB margin below the average limit of 15.209 and 15.249. The radiated emissions for the EUT meet the requirements for FCC CFR 47 Part 15.249 Intentional Radiators. There are no measurable emissions in the restricted bands other than those recorded in this report. Other emissions were present with amplitudes at least 20 dB below the FCC Limits.

## Frequency Stability

### Measurements Required

Temperature stability was measured for the operating temperature range and voltage variations of the unit and recorded.

- (1) Vary primary supply voltage from 85 to 115 percent of the nominal value for other than hand carried battery equipment.
- (2) For hand carried, batteries powered equipment, reduce primary supply voltage to the battery-operating end-point, which shall be specified by the manufacturer.
- (3) The supply voltage shall be measured at the input to the cable normally provided with the equipment, or at the power supply terminals if cables are not normally provided.

### Test Arrangement

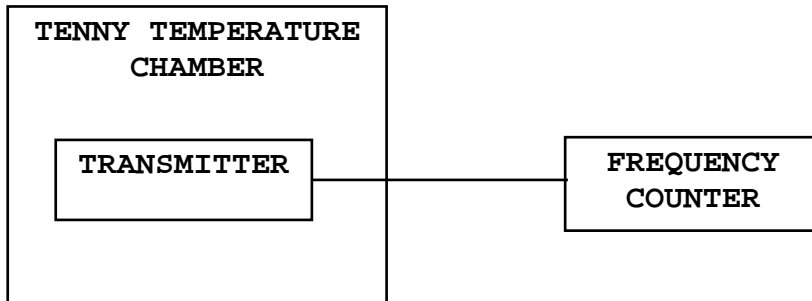

The measurement procedure outlined below shall be followed:

Step 1: The transmitter shall be installed in an environmental test chamber whose temperature is controllable. Provision shall be made to measure the frequency of the transmitter.

Step 2: With the transmitter inoperative (power switched "OFF"), the temperature of the test chamber shall be adjusted to +25°C. After a temperature stabilization period of one hour at +25°C, the transmitter shall be switched "ON" with standard test voltage applied.

Step 3: The carrier shall be keyed "ON", and the transmitter shall be operated unmodulated at full radio frequency power output at the duty cycle for which it is rated, for duration of at least 5 minutes. The radio frequency carrier frequency shall be monitored and measurements shall be recorded.

Step 4: The test procedures outlined in Steps 2 and 3, shall be repeated after stabilizing the transmitter at the environmental temperatures specified.

The frequency stability was measured with variations in the power supply voltage from 85 to 115 percent of the nominal value. A Sorenson DC Power Source was used to vary the dc voltage for the power input from 11.7 Vdc to 15.8 Vdc. The frequency was measured and the variation in parts per million was calculated.

**Results**

Nominal frequency 2,441.00 MHz	FREQUENCY STABILITY VS TEMPERATURE IN PARTS PER MILLION (PPM) and percent								
	Temperature in °C								
	-30	-20	-10	0	+10	+20	+30	+40	+50
Change (Hz)	400.0	700.0	0.0	0.0	0.0	0.0	-100.0	0.0	200.0
PPM	0.164	0.287	0.000	0.000	0.000	0.000	-0.041	0.000	0.082
%	0.00	0.00	0.00	0.00	0.00	0.00	0.00	0.00	0.00

FREQUENCY IN MHz	STABILITY VS VOLTAGE VARIATION ±15% IN PPM		
	INPUT VOLTAGE		
	11.7 V <sub>dc</sub>	13.8 V <sub>dc</sub>	15.8 V <sub>dc</sub>
2441.000	0	0	0

Specifications of Paragraphs 15.249 are met. There are no deviations to the specifications.



**Summary of Results for Frequency Stability**

The EUT fulfills the requirements for FCC Part 15C Intentional Radiators frequency stability. The EUT had a 0.3-PPM worst-case stability at -20 degrees centigrade.

**Statement of Modifications and Deviations**

No modifications to the EUT were required for the unit to meet the FCC CFR 47 Parts 15B & 15C, Class B Emissions Standards. There were no deviations to the specifications.

## APPENDIX

Model: 011-01326-0X

1. Test Equipment List.
2. Rogers Qualifications.
3. FCC Site Approval Letter.

**TEST EQUIPMENT LIST FOR ROGERS LABS, INC.**

The test equipment used is maintained in calibration and good operating condition. Use of this calibrated equipment ensures measurements are traceable to national standards.

<u>List of Test Equipment:</u>	<u>Calibration Date:</u>
Scope: Tektronix 2230	2/05
Wattmeter: Bird 43 with Load Bird 8085	2/05
Power Supplies: Sorensen SRL 20-25, SRL 40-25, DCR 150, DCR 140	2/05
H/V Power Supply: Fluke Model: 408B (SN: 573)	2/05
R.F. Generator: HP 606A	2/05
R.F. Generator: HP 8614A	2/05
R.F. Generator: HP 8640B	2/05
Spectrum Analyzer: HP 8562A,	2/05
Mixers: 11517A, 11970A, 11970K, 11970U, 11970V, 11970W	
HP Adapters: 11518, 11519, 11520	
Spectrum Analyzer: HP 8591 EM	5/05
Frequency Counter: Leader LDC 825	2/05
Antenna: EMCO Biconilog Model: 3143	5/05
Antenna: EMCO Log Periodic Model: 3147	10/05
Antenna: Antenna Research Biconical Model: BCD 235	10/05
Antenna: EMCO Dipole Set 3121C	2/05
Antenna: C.D. B-101	2/05
Antenna: Solar 9229-1 & 9230-1	2/05
Antenna: EMCO 6509	2/05
Audio Oscillator: H.P. 201CD	2/05
R.F. Power Amp 65W Model: 470-A-1010	2/05
R.F. Power Amp 50W M185- 10-501	2/05
R.F. PreAmp CPPA-102	2/05
LISN 50 µHy/50 ohm/0.1 µf	10/05
LISN Compliance Eng. 240/20	2/05
LISN Fischer Custom Communications FCC-LISN-50-16-2-08	6/05
Peavey Power Amp Model: IPS 801	2/05
Power Amp A.R. Model: 10W 1010M7	2/05
Power Amp EIN Model: A301	2/05
ELGAR Model: 1751	2/05
ELGAR Model: TG 704A-3D	2/05
ESD Test Set 2010i	2/05
Fast Transient Burst Generator Model: EFT/B-101	2/05
Current Probe: Singer CP-105	2/05
Current Probe: Solar 9108-1N	2/05
Field Intensity Meter: EFM-018	2/05
KEYTEK Ecat Surge Generator	2/05
Shielded Room 5 M x 3 M x 3.0 M (101 dB Integrity)	
10/20/2005	

**QUALIFICATIONS**

Of

**SCOT D. ROGERS, ENGINEER**

**ROGERS LABS, INC.**

Mr. Rogers has approximately 17 years experience in the field of electronics. Six years working in the automated controls industry and 6 years working with the design, development and testing of radio communications and electronic equipment.

**POSITIONS HELD:**

Systems Engineer: A/C Controls Mfg. Co., Inc.  
6 Years

Electrical Engineer: Rogers Consulting Labs, Inc.  
5 Years

Electrical Engineer: Rogers Labs, Inc.  
Current

**EDUCATIONAL BACKGROUND:**

- 1) Bachelor of Science Degree in Electrical Engineering from Kansas State University.
- 2) Bachelor of Science Degree in Business Administration Kansas State University.
- 3) Several Specialized Training courses and seminars pertaining to Microprocessors and Software programming.

*Scot D Rogers*

Scot D. Rogers

February 8, 2006

Date

1/11/03

**FEDERAL COMMUNICATIONS COMMISSION****Laboratory Division  
7435 Oakland Mills Road  
Columbia, MD 21046**

August 15, 2003

Registration Number: 90910

Rogers Labs, Inc.  
4405 West 259th Terrace  
Louisburg, KS 66053

Attention: Scot Rogers

Re: Measurement facility located at Louisburg  
3 & 10 meter site  
Date of Renewal: August 15, 2003

Dear Sir or Madam:

Your request for renewal of the registration of the subject measurement facility has been received. The information submitted has been placed in your file and the registration has been renewed. The name of your organization will remain on the list of facilities whose measurement data will be accepted in conjunction with applications for Certification under Parts 15 or 18 of the Commission's Rules. Please note that the file must be updated for any changes made to the facility and the registration must be renewed at least every three years.

Measurement facilities that have indicated that they are available to the public to perform measurement services on a fee basis may be found on the FCC website [www.fcc.gov](http://www.fcc.gov) under E-Filing, OET Equipment Authorization Electronic Filing, Test Firms.

Sincerely,

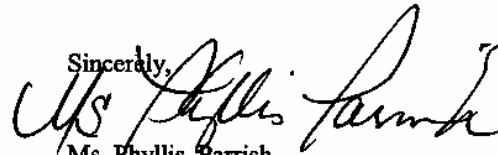
Ms. Phyllis Parrish  
Information Technician