

ECM WIRING

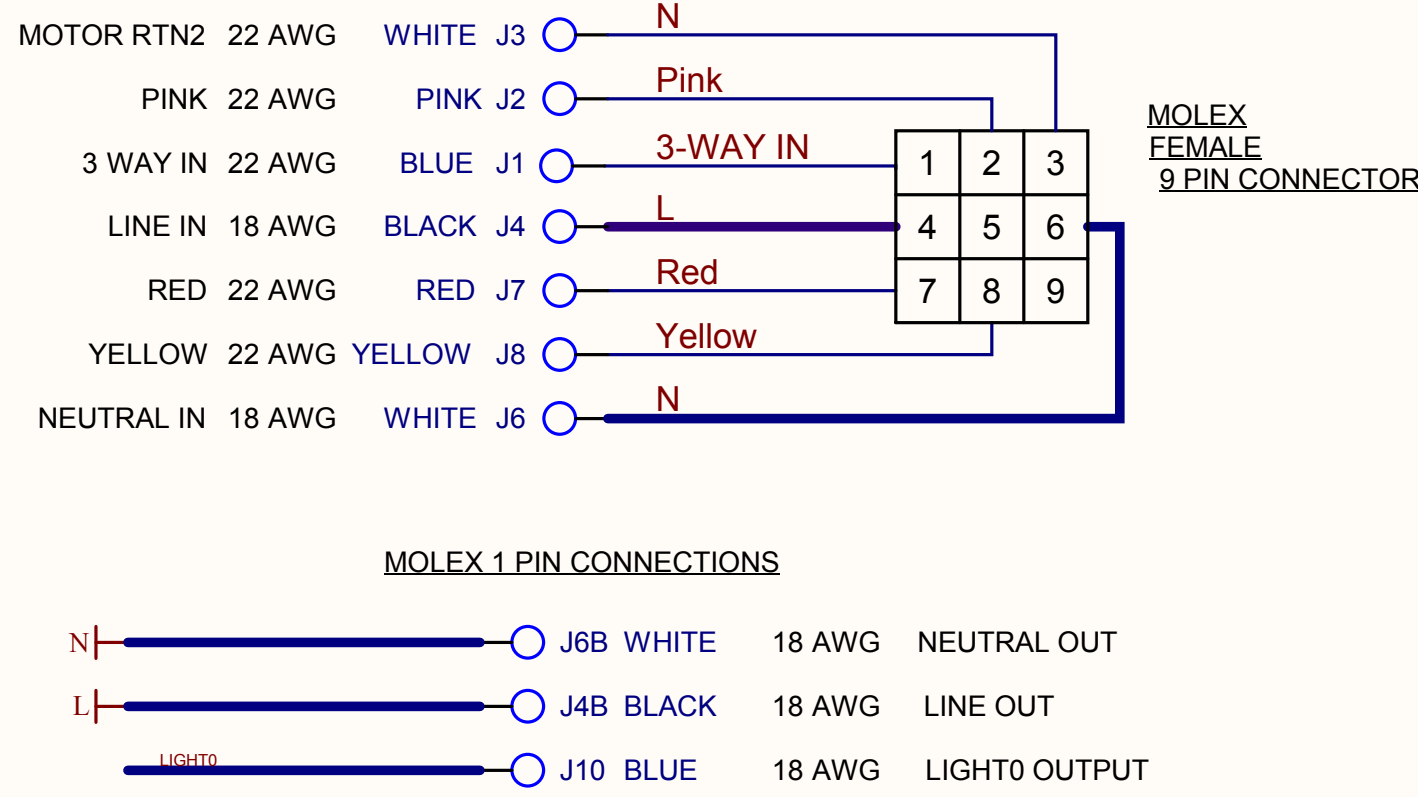

PROGRAMMING HEADER

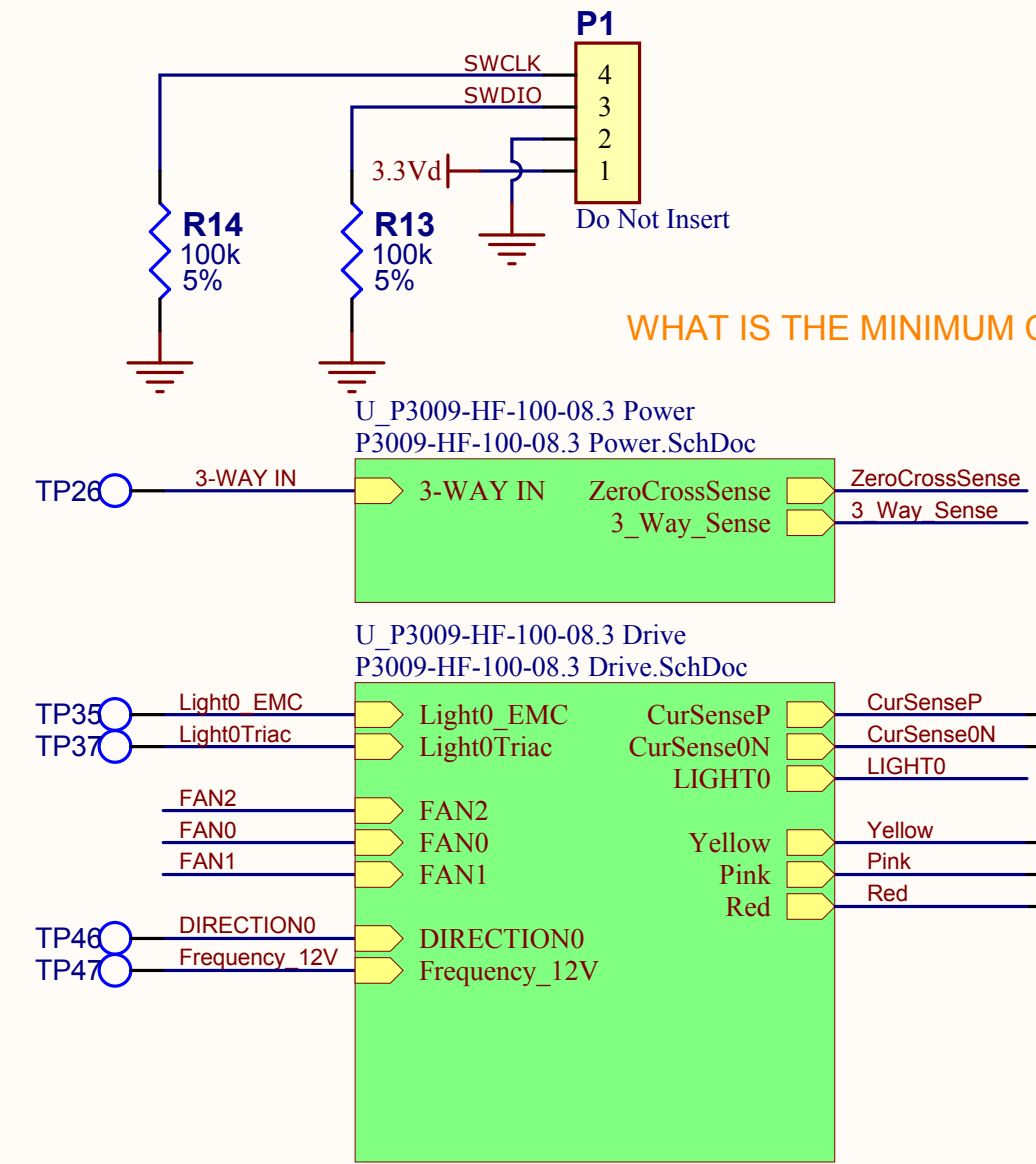

WHAT IS THE MINIMUM CURREN? MUST BE >3Ma

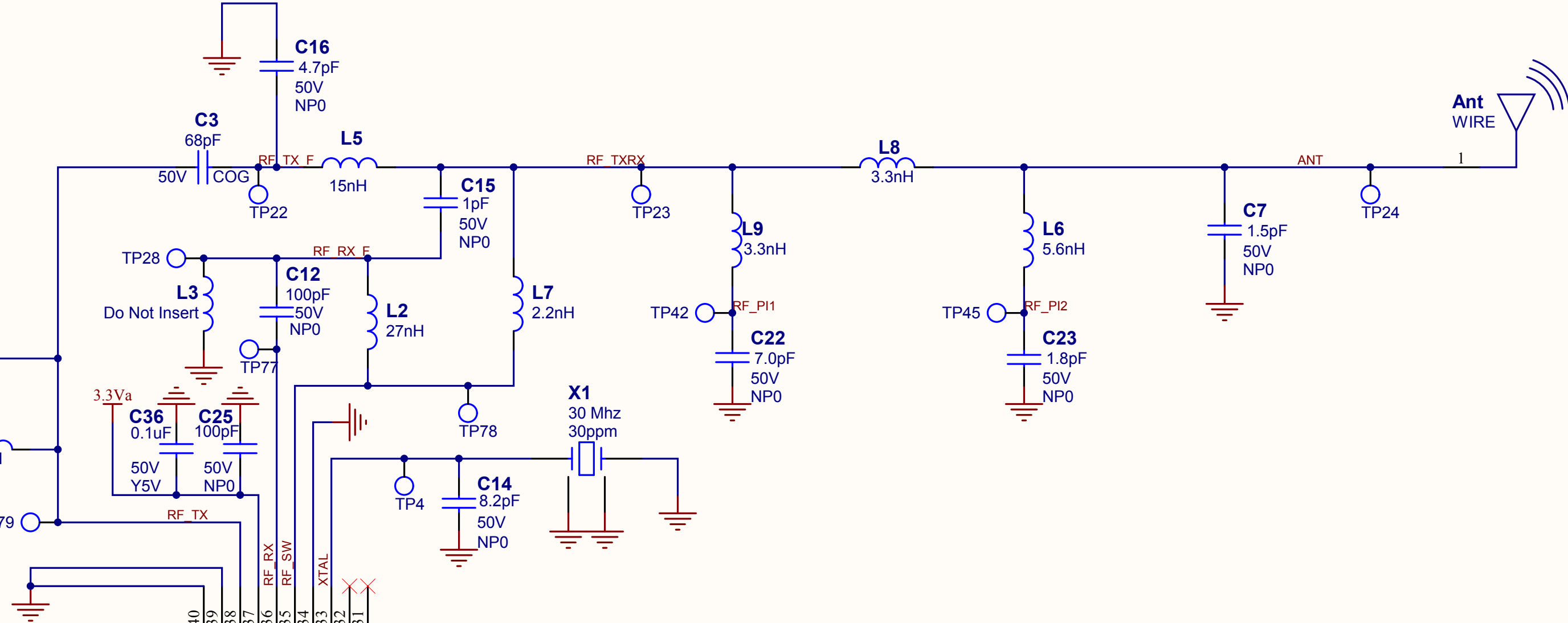
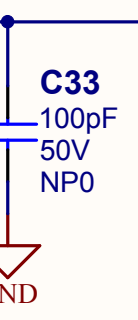

MODULE INTERFACE

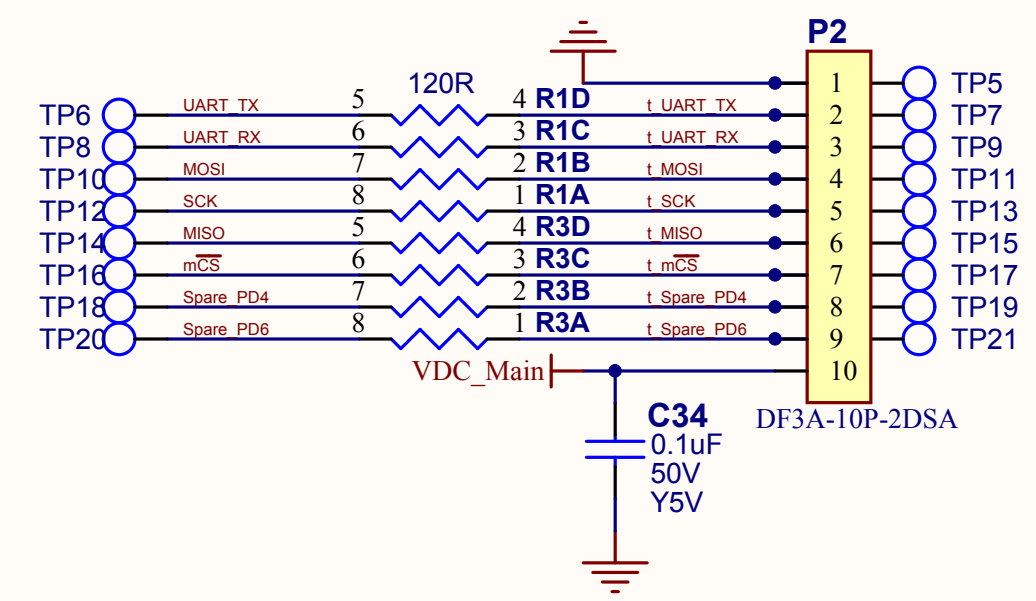

FW CONFIGURATION

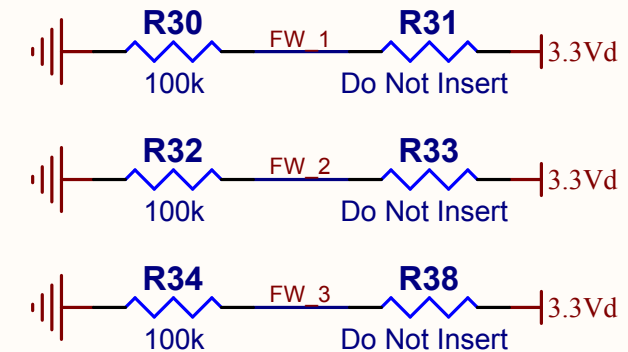

FIDUCIALS

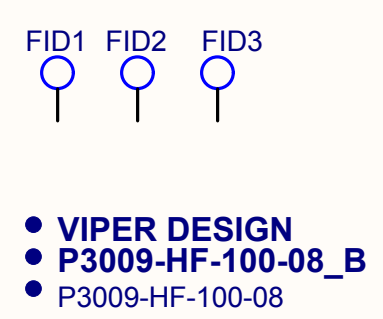

UNLESS OTHERWISE SPECIFIED

Resistors
 Values are in Ohms
 Tolerance values are +-5%
 Power Rating is 1/10W

Capacitors
 Values are in Farads
 Voltage ratings are shown

Inductors
 Values are in Henries
 Tolerance values are +-5%

DO NOT SCALE DRAWING

Your Complete Electronic Solution

2009 Skyhawk Court
 White House, TN 37188
 phone: 615-654-9710
 brian@viper-design.com

DESCRIPTION/PART NAME		
ECM Gen 2.0 - Controller PROTOTYPE		
DRAWNBY BKB	DATE 3/7/2016	SCALE B
DWG NO. P3009-HF-100	PAGE 1/3	

Rev	Date	By	Description
1.0	03/05/14	BKB	Initial Release
2.0	08/21/14	BKB	Updates from POC and ADK GEN 2.0 POC.
3.0	10/23/14	BKB	Initial Release
3.0	11/04/14	BKB	Updated the Stereo Jack to a 4 conductor Microphone Jack for better FanDangle Operation.
3.0	11/06/14	BKB	Swapped PC0 and PC1 pins.
3.0	11/06/14	BKB	Removed pz_frequency signal. Direct piezo drive from ASIC.
3.0	11/12/14	BKB	Added additional White Neutral wires for the external connections.
3.0	11/23/14	BKB	Changed the Module Connector to interlocking Molex.
3.0	12/10/14	BKB	Connected FanDangle Signals to Analog Inputs from digital inputs.
3.0	12/10/14	BKB	Changed Oscillator to smaller package
3.0	02/03/15	BKB	Change Fan0 and Fan1 positions.
3.0	02/03/15	BKB	Added Pass-through connections for power.
3.0	02/04/15	BKB	Changed the 3.5mm to the 4 conductor version ST-320A-RS. Still need a higher profile version.
3.0	02/05/15	BKB	Changed the pinout on the FanDangle section of Krankl.
4.0	03/04/15	BKB	Initial Release
5.0	04/18/15	BKB	Initial Release
5.0	05/11/15	BKB	Fixed the FanDangle Jack Pinout error: Pin 2 and Pin 4 were swapped.
6.0	05/25/15	BKB	Initial Release
6.0	05/25/15	BKB	Rewired 9 pin motor connector for conventional motor reversing.
6.1	06/11/15	JAC	Depopulated FanDangle circuit
7.0	8/31/15	BKB	Remove FanDangle Circuitry, Changed Module Connector, pinout change on module.
8.0	10/16/15	BKB	Initial Release
8.1	02/19/16	BKB	Initial Release, Transceiver Component Changes
8.2	02/29/16	BKB	Initial Release, More FCC Component Changes, CM Alternates
8.3	03/04/16	BKB	Initial Release.

VIPER ACTION ITEMS
 NEEDS ADK INPUT
 NEEDS HF INPUT

PROPRIETARY AND CONFIDENTIAL MATERIAL
 This drawing or material is submitted to you with confidence that it will be used only for your information on application engineering studies and shall never be used in any manner detrimental to our interest

FAN CONTROL

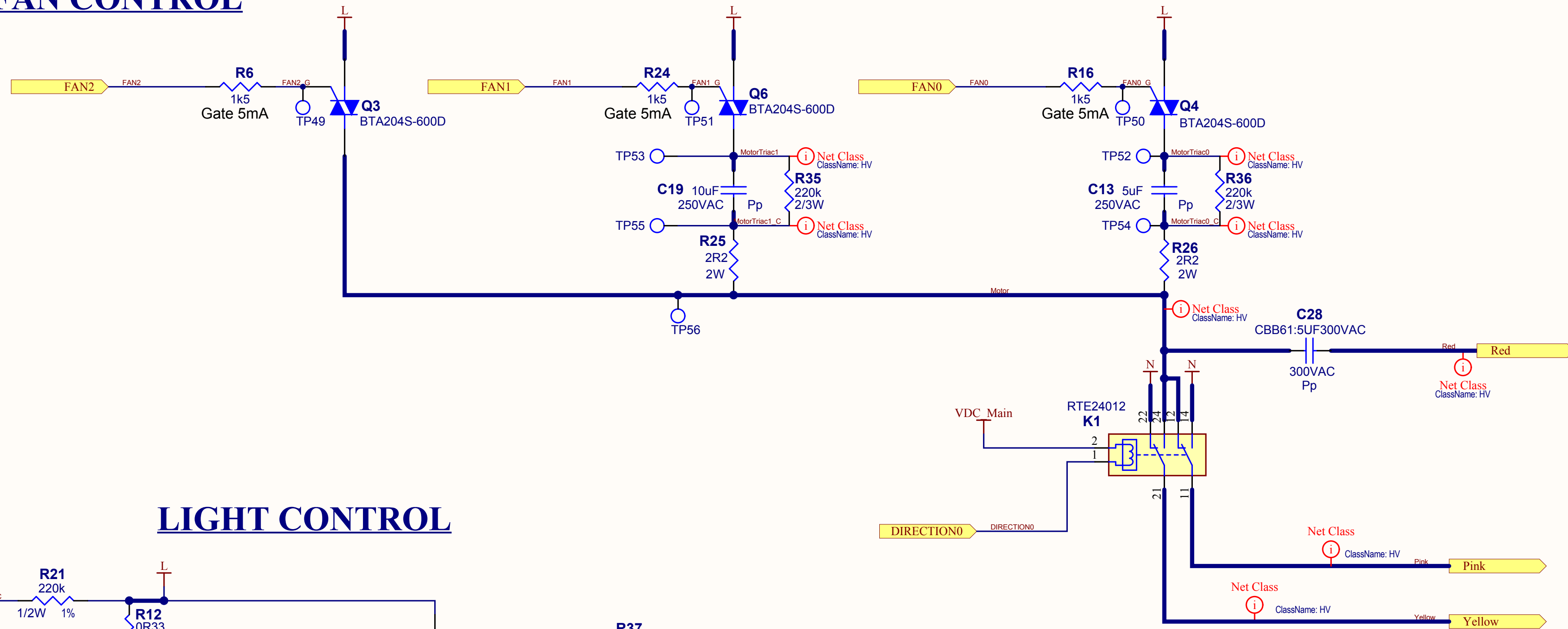

LIGHT CONTROL

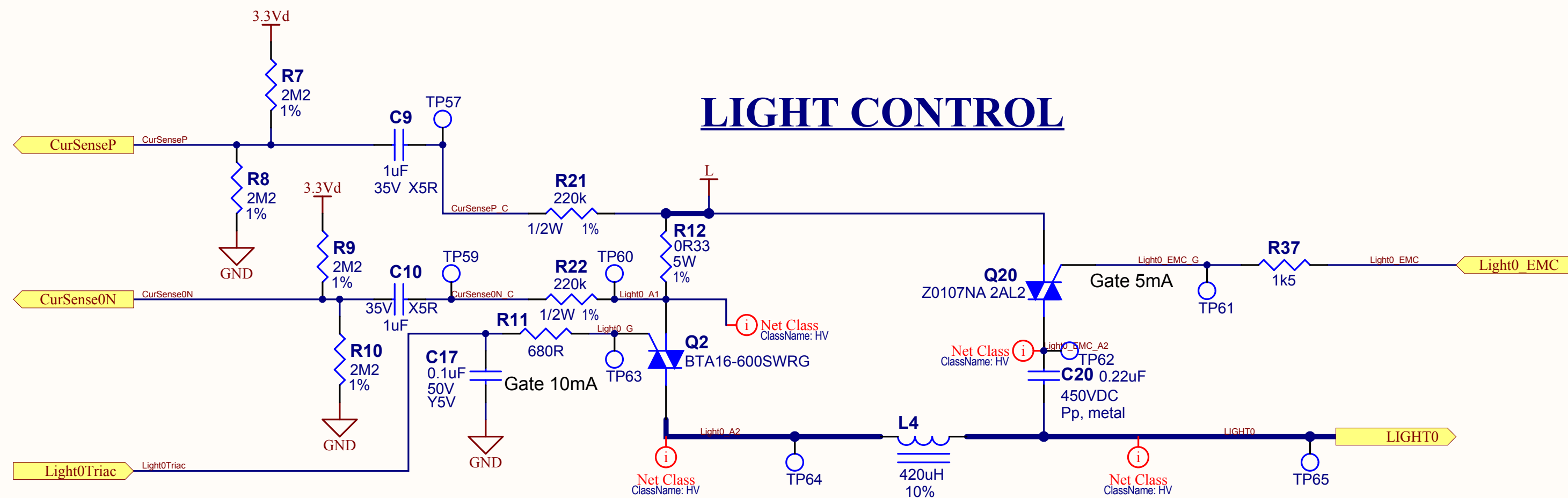

PIEZO CIRCUIT

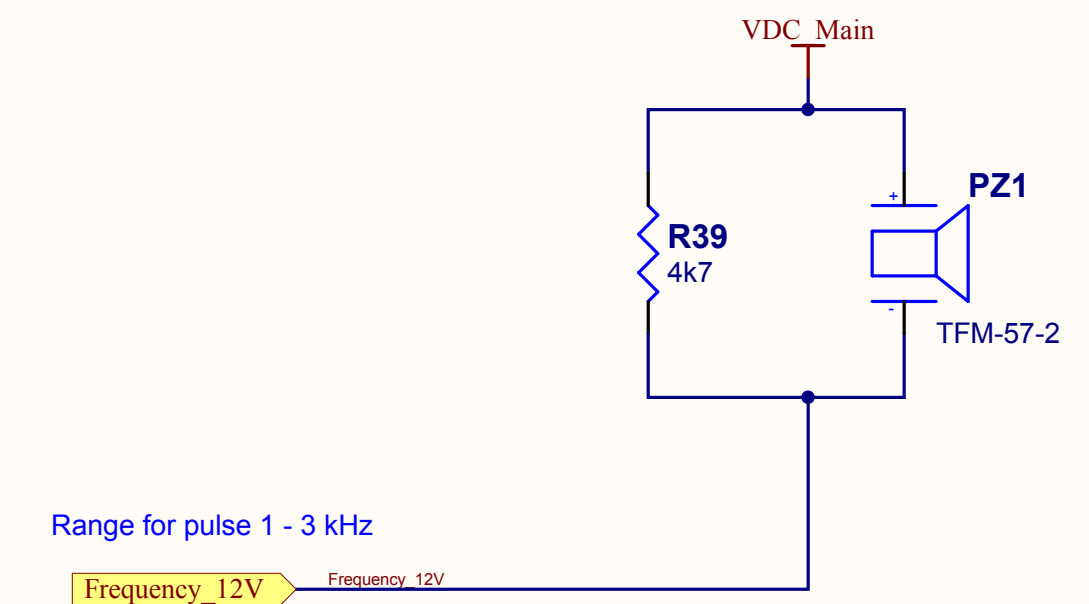

Rev	Date	By	Description
1.0	03/05/14	BKB	Initial Release
2.0	08/21/14	BKB	Updates from POC and ADK GEN 2.0 POC.
3.0	10/23/14	BKB	Initial Release
3.0	11/06/14	BKB	Removed external piezo drive components (Q7, R45, R30). Direct ASIC drive of piezo.
3.0	02/03/15	BKB	Change Fan0 and Fan1 positions.
4.0	03/04/15	BKB	Initial Release
5.0	04/18/15	BKB	Initial Release
5.0	05/11/15	BKB	Changed the Normally Closed Position of the relay to the downdraft state.
6.0	05/25/15	BKB	Initial Release
6.0	05/25/15	BKB	Rewired 9 pin motor connector for conventional motor reversing.
7.0	08/31/15	BKB	Initial Release.
8.0	10/16/15	BKB	Initial Release
8.1	01/15/16	BKB	Initial Release, Improved performance of Light Power Detection
8.2	02/29/16	BKB	Initial Release, CM Alternates
8.3	03/04/16	BKB	Initial Release.

UNLESS OTHERWISE SPECIFIED
Resistors
 Values are in Ohms
 Tolerance values are +/-5%
 Power Rating is 1/10W
Capacitors
 Values are in Farads
 Voltage ratings are shown
Inductors
 Values are in Henries
 Tolerance values are +/-5%
DO NOT SCALE DRAWING

Your Complete Electronic Solution

2009 Skyhawk Court
White House, TN 37188
phone: 615-654-9710
brian@viper-design.com

PROPRIETARY AND CONFIDENTIAL MATERIAL
 This drawing or material is submitted to you with confidence that it will be used only for your information on application engineering studies and shall never be used in any manner detrimental to our interest

DESCRIPTION/PART NAME		
ECM Gen 2.0 - Drive PROTOTYPE		
DRAWNBY BKB	DATE 3/7/2016	SCALE C
DWG NO. P3009-HF-100	PAGE 2 3	

OFFLINE POWER SUPPLY

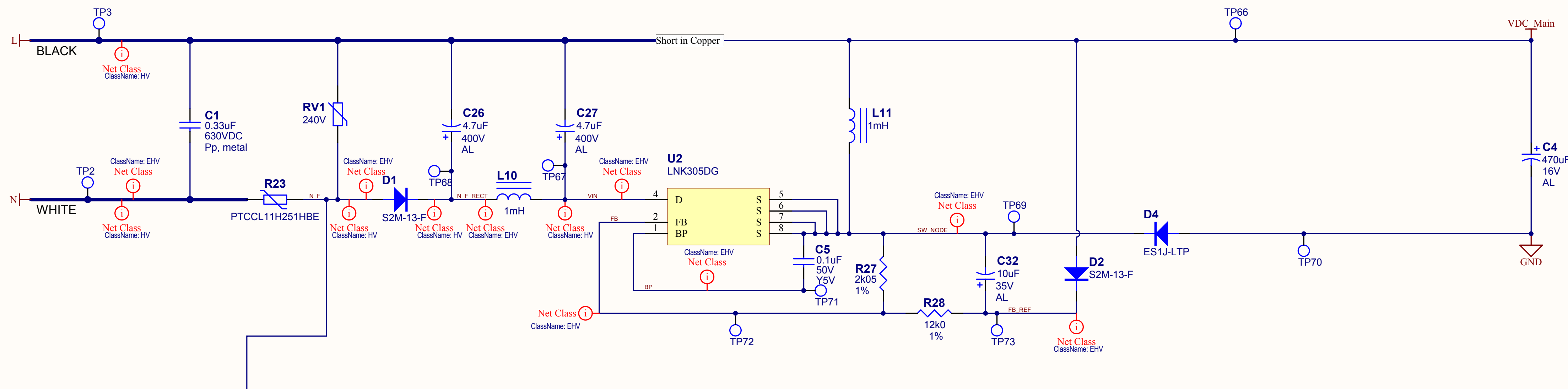

ZERO CROSS DETECTOR

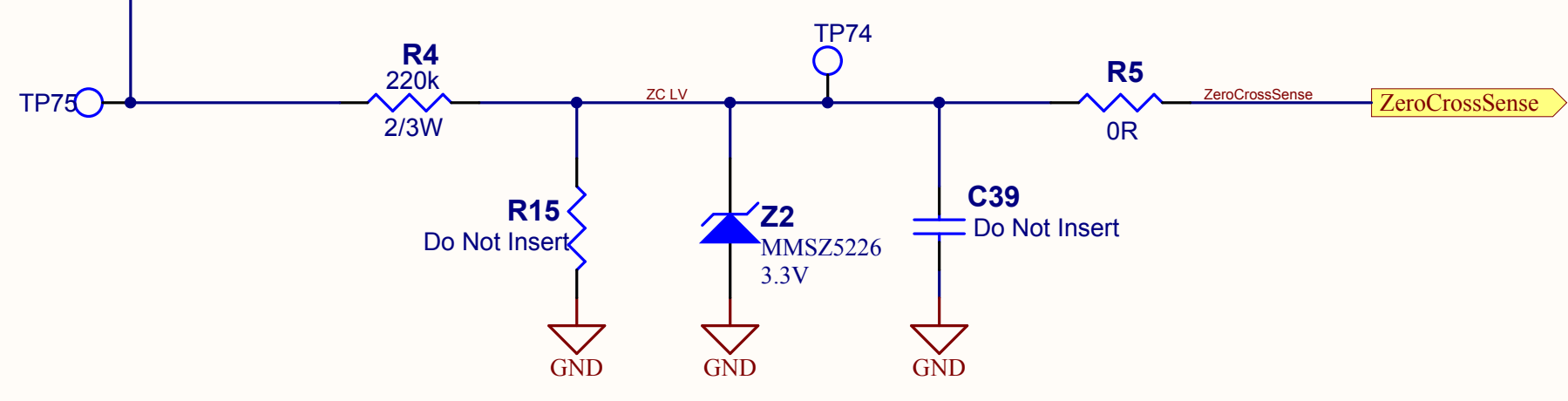

3 WAY SWITCH MONITOR

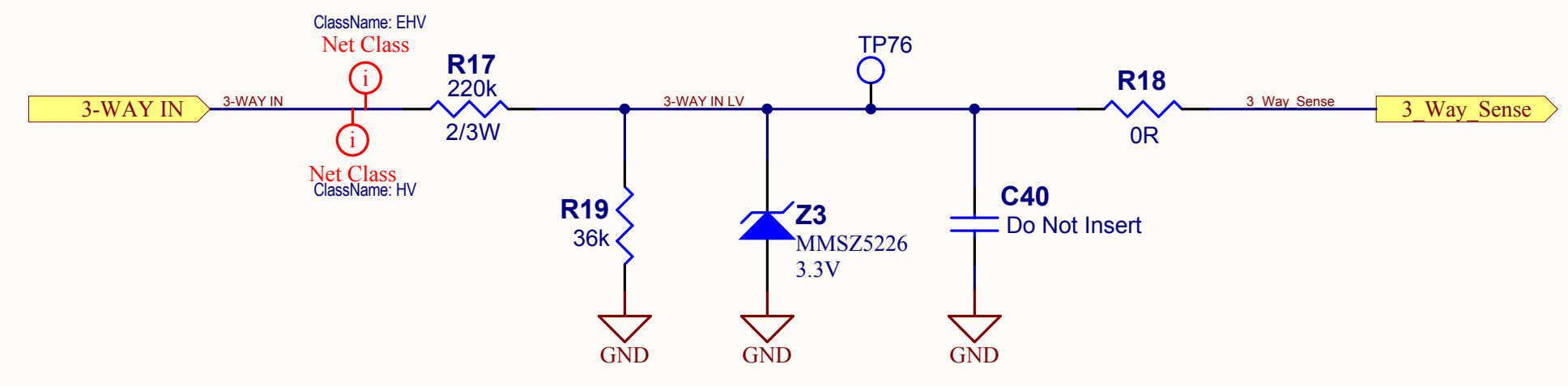

Rev	Date	By	Description
1.0	03/05/14	BKB	Initial Release
2.0	08/21/14	BKB	Updates from POC and ADK GEN 2.0 POC.
3.0	10/23/14	BKB	Initial Release
3.0	11/04/14	BKB	Added capacitors in parallel with zeners for noise filtering on ZCDs.
4.0	03/04/15	BKB	Initial Release
5.0	04/18/15	BKB	Initial Release
5.0	04/21/15	BKB	Increased Varistor Voltage of RV1
5.0	05/11/15	BKB	Updated the Zero Cross and 3 Way Switch circuitry.
6.0	05/25/15	BKB	Initial Release
6.0	05/25/15	BKB	Updated 3 Way Switch Circuitry to detect a Line Voltage Input.
7.0	08/31/15	BKB	Initial Release.
8.0	10/16/15	BKB	Initial Release
8.1	01/15/16	BKB	Initial Release
8.2	02/29/16	BKB	Initial Release, Increased Temperature rating of C26,C27 to 105 C
8.3	03/04/16	BKB	Initial Release, Changed voltage rating of Varistor RV1.

UNLESS OTHERWISE SPECIFIED
Resistors
 Values are in Ohms
 Tolerance values are +-5%
 Power Rating is 1/10W
Capacitors
 Values are in Farads
 Voltage ratings are shown
Inductors
 Values are in Henries
 Tolerance values are +-5%
DO NOT SCALE DRAWING



PROPRIETARY AND CONFIDENTIAL MATERIAL
 This drawing or material is submitted to you with confidence that it will be used only for your information on application engineering studies and shall never be used in any manner detrimental to our interest

DESCRIPTION/PART NAME		
ECM Gen 2.0 - Power PROTOTYPE		
DRAWNBY BKB	DATE 3/7/2016	SCALE C
DWG NO. P3009-HF-100		PAGE 3 3