

# **SIMPLEconnect™**

programmable control

model 99107

installation and setup guide

*Hunter®*

# installation

- 1 **If your fan has pull chains, use the pull chains to set the fan speed to HIGH and the light to ON before disconnecting power.**

- 2 **Ensure that power is OFF at the circuit breaker before proceeding with installation.**

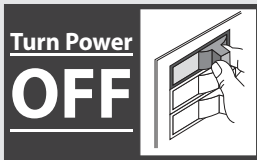

- 3 **Unscrew and lower the canopy. Remove the wire connectors that connect the wires from the ceiling to the fan, leaving the grounding wires connected.**

If uncertain how to do this, reference the fan's owner's manual. Hunter fan manuals can be found on [www.HunterFan.com](http://www.HunterFan.com).

**Note:** With wiring exposed, it may be helpful to note existing wire connections or take a digital photo for reference before removing the wire connectors.

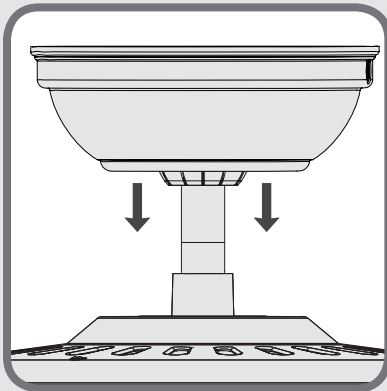

# installation (continued)

- 4** Choose the hanging system that most closely resembles the one used by your fan and place the receiver as shown.

**WARNING:** This receiver cannot be installed in conjunction with any other receiver or hard-wired wall control. Doing so will void your warranty.

**Hanging System 1**

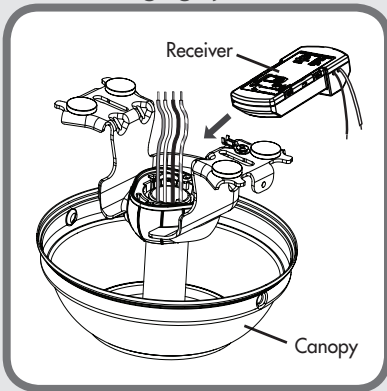

**Hanging System 2**

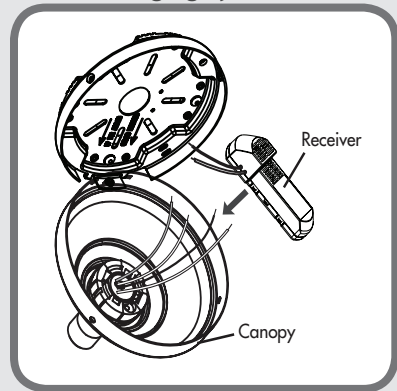

**Hanging System 3**

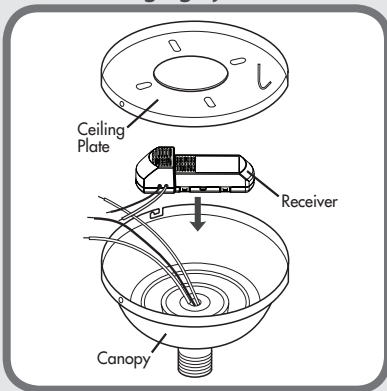

**Hanging System 4**

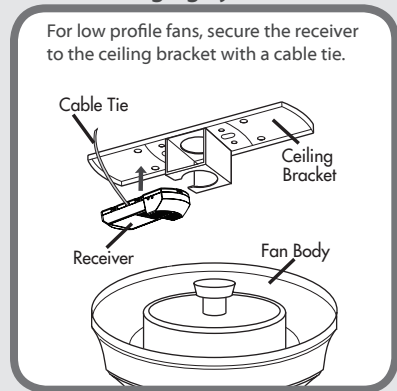

For low profile fans, secure the receiver to the ceiling bracket with a cable tie.

**Note:** If your canopy is crowded with excess wire, you may wish to cut the excess fan wires. Leave a minimum of 8 inches remaining. Strip the fan lead wires 1/2 inch. Place remaining excess wire into the ceiling electrical box. **The bracket and fan must remain properly grounded.**

If the fan is installed on an angled ceiling and you need assistance with installation, please call 1-888-830-1326.

## installation (continued)

5

**Connect wires from the receiver to wires from the fan as shown.**

Using the wire connectors:

- Connect the blue wire from the receiver to the light wire (blue or possibly black with white stripe) from the fan.
- Connect the yellow wire from the receiver to the motor wire (black) from the fan.

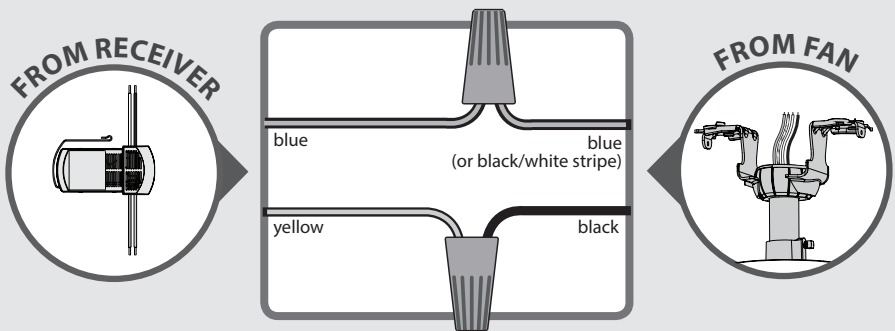

**Note:** If you're uncertain about wire colors or connections, please contact a qualified electrician.

To avoid possible electrical shock, before installing or servicing your fan, disconnect the power by turning off the circuit breakers to the outlet box and associated wall switch location. If you cannot lock the circuit breakers in the off position, securely fasten a prominent warning device, such as a tag, to the service panel.



Turn the connectors upward and push them carefully back through the hanger bracket into the outlet box. Spread the wires apart, with the grounded wires on one side of the outlet box and the ungrounded wires on the other side of the outlet box.



## installation (continued)

### 6 Connect wires from the fan and receiver to wires from the ceiling as shown.

Using the wire connectors:

- Connect the black wire (ungrounded) from the ceiling to the black wire from the receiver.
- Connect the white wire (grounded) from the ceiling to both the white wire from the receiver and the white wire from the fan.

**Note:** If you have a dual switch, please cap the secondary power wire from the ceiling. This will result in one unused switch.

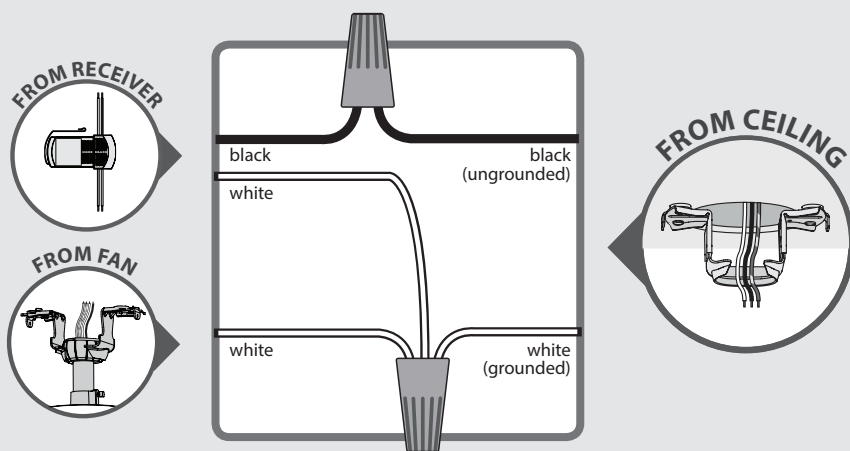

**Note:** If you're uncertain about wire colors or connections, please contact a qualified electrician.

### 7 After all wires are connected and secured with wire connectors, reinstall the canopy.

If uncertain how to install the canopy, reference the fan's owner's manual.

### 8 Restore power at the circuit breaker.

# setup

1

## Install the app.

Visit your app store and search **simpleconnect** to find the app.



2

## Plug in the wall control.

**Note:** You may wish to write down the PIN, which can be found on the wall control. You will need the PIN to complete step 5 on this page.

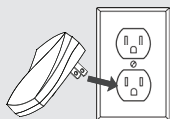

*Maximum distance from the wall control to the fan/receiver is 80 feet.*

**PIN:**

|  |  |  |  |
|--|--|--|--|
|  |  |  |  |
|--|--|--|--|

3

## Launch the app.

Ensure that Bluetooth® is enabled on your iOS or Android device before launching the app.

4

## Tap the Controller button.

If you are installing multiple wall controls, be sure to tap the Controller button that coincides with the correct wall control.

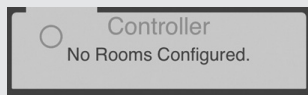

5

## Enter the PIN.

The 4-digit PIN can be found on the wall control. Tap *Done* when finished.



## Congratulations!

You have successfully set up your programmable control. You may now begin using the app to take control of your fan!

**Remember:** The app only works while in range of the wall control. If you would like your fan and lights to operate while you are away, you must first use the app to schedule an event.

**Dimming:** In the app, navigate to the “Rooms Configured” settings screen and tap the Gear icon next to your room. Here you can turn the dimming feature on or off. This may cause faulty operation if your bulbs do not support dimming.

# setup for additional fans

## If you wish to operate multiple fans with one wall control:

1. You will need an additional receiver (sold separately) for each fan. Complete the Installation section to install each receiver into your fan(s). Receivers can be purchased at [www.HunterFan.com](http://www.HunterFan.com).
2. Tap the Gear icon on the main screen to navigate to the "Rooms Configured" settings screen.
3. Perform steps a-d on this page to complete setup.



### Tap the Gear icon shown below.

Be sure to choose a Gear icon for a room that is not already configured.

**Note:** There is a maximum four rooms per wall control.

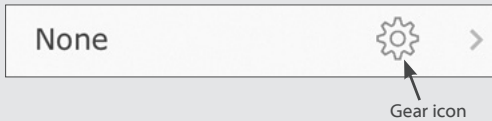

**To prevent faulty operation, please disconnect power from all other ceiling fans within range while performing the next three steps.**



### Tap the Pair Device button.

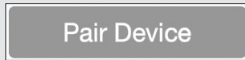

*If your bulbs support dimming, you may also turn on the dimming feature at this screen.*



### Cycle power to the fan.

Turn power off and back on at the wall (or circuit breaker if necessary).

The next step must be completed **WITHIN THREE MINUTES** of restoring power to the fan.



### Tap OK to confirm pairing.

**Note:** The lights will flash (if applicable) and the fan will turn on at low speed. This is visual confirmation that the pairing was successful.



### Congratulations!

You have successfully set up your additional receiver. **Tap the Back button twice to begin using the app to take control of your fan!**

# optional ON/OFF remote

## maintenance

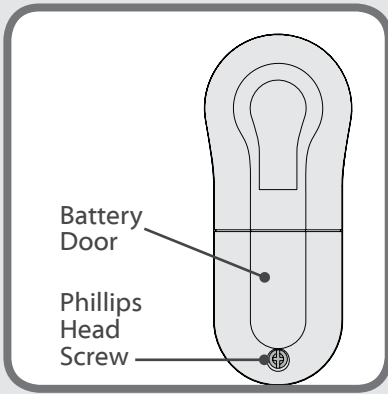

## Installing/Replacing the Battery

To access the battery compartment, remove the small Phillips head screw that secures the battery door to the transmitter assembly.

The battery should be installed with the positive (+) side up.

Replace with a CR2032 battery when necessary.

## pairing

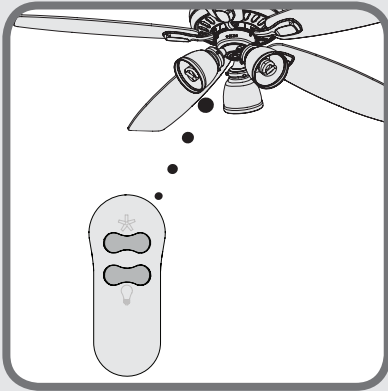

## No Pairing Required!

The optional ON/OFF remote is already paired to the receiver and ready to use.

If the battery is working (the buttons should illuminate when pressed) but the remote does not operate the fan, or if you would like to pair the remote to additional receiver(s), please see the Troubleshooting section on the following page.

## operation

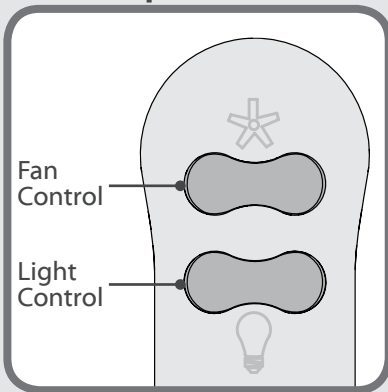

## Fan Operation

Press and release the Fan button on the remote control to turn the fan off or on.

## Light Operation

Press and quickly release the Light button on the remote control to turn the light off or on.



# troubleshooting

## **CFL Bulbs Flicker**

Tap the Gear icon in the Room setup screen to visit the settings screen for the appropriate room or fan. If Dimming Mode is on, turn off Dimming Mode. If the problem is not corrected, unpair and re-pair the device with Dimming Mode disabled.

## **Fan will not start**

- Make sure the power is on at the circuit breaker and the wall switch.
- Make sure that the transmitter and receiver are paired.
- Check wire connections inside of the canopy.

## **ON/OFF remote only works when held at close range**

- Change battery.

## **ON/OFF remote is not paired**

The ON/OFF remote should already be paired to the fan receiver. If the ON/OFF remote is not paired, perform the following steps:

1. To prevent faulty operation, please disconnect power from all other ceiling fans within range while performing these steps.
2. Turn the fan power off and back on at the wall switch (or circuit breaker if necessary).
3. Within three minutes of restoring power to the fan, press and hold both the Fan button and the Light button for at least four seconds.

**Note:** The lights will flash (if applicable) and the fan will turn on at low speed. This is visual confirmation that the pairing was successful.

## HUNTER FAN COMPANY CONTROL - LIMITED WARRANTY

The Hunter Fan Company makes the following limited warranty to the original purchaser of the Control ("Control"): Your Control is warranted to be free from defects in material and workmanship for a period of one year from the date of sale. If the Control malfunctions or fails within the warranty period due to a defect in material or workmanship we will replace it free of charge. IF THE ORIGINAL PURCHASER CEASES TO OWN THE CONTROL, THIS WARRANTY AND ANY IMPLIED WARRANTY, INCLUDING BUT NOT LIMITED TO ANY IMPLIED WARRANTY OF MERCHANTABILITY OR FITNESS FOR A PARTICULAR PURPOSE, ARE VOIDED. THIS WARRANTY IS IN LIEU OF ALL OTHER EXPRESS WARRANTIES. THE DURATION OF ANY IMPLIED WARRANTY, INCLUDING, BUT NOT LIMITED TO, ANY IMPLIED WARRANTY OF MERCHANTABILITY OR FITNESS FOR A PARTICULAR PURPOSE, IN RESPECT TO ANY CONTROL, IS EXPRESSLY LIMITED TO THE PERIOD OF THE EXPRESS WARRANTY SET FORTH ABOVE FOR SUCH CONTROL. This warranty excludes malfunctions or failures which were caused by repairs by persons not authorized by us, mishandling, improper installation, modifications, or damage to the Control while in your possession, or unreasonable use. This warranty does not apply to batteries or to deterioration or damage to the product caused by the use of faulty batteries. IN NO EVENT SHALL HUNTER FAN COMPANY BE LIABLE FOR CONSEQUENTIAL OR INCIDENTAL DAMAGES. SOME STATES DO NOT ALLOW LIMITATIONS ON HOW LONG AN IMPLIED WARRANTY LASTS OR THE EXCLUSION OR LIMITATIONS OF INCIDENTAL OR CONSEQUENTIAL DAMAGES SO THE ABOVE LIMITATIONS OR EXCLUSIONS MAY NOT APPLY TO YOU. THIS WARRANTY GIVES YOU SPECIFIC LEGAL RIGHTS AND YOU MAY ALSO HAVE OTHER RIGHTS WHICH VARY FROM STATE TO STATE.

---

If you have problems or questions, please contact us.

1-888-830-1326

[www.HunterFan.com](http://www.HunterFan.com)

7130 Goodlett Farms Pkwy, Ste 400, Memphis, TN 38016

---

Compatible with iOS 7.1 or higher / Android 4.3 or higher  
Android and Google Play are trademarks of Google Inc.  
Apple logo is a trademark of Apple, Inc.  
App store is a service mark of Apple, Inc.  
Bluetooth is a registered trademark of Bluetooth SIG

---

### Read and Save These Instructions

This product conforms to UL Standard 60950.

#### **WARNINGS**

This device complies with part 15 of the FCC Rules. Operation is subject to the following two conditions: (1) this device may not cause harmful interference, and (2) this device must accept any interference received, including interference that may cause undesired operation.

This device complies with RSS-210 of Industry Canada. Operation is subject to the following two conditions: (1) this device may not cause interference, and (2) this device must accept any interference, including interference that may cause undesired operation of the device.

This equipment has been tested and found to comply with the limits for a Class B digital device, pursuant to Part 15 of the FCC Rules. These limits are designed to provide reasonable protection against harmful interference in a residential installation. This equipment generates, uses and can radiate radio frequency energy and, if not installed and used in accordance with the instructions, may cause harmful interference to radio communications. However there is no guarantee that interference will not occur in a particular installation. If this equipment does cause harmful interference to radio or television reception, which can be determined by turning the equipment off and on, the user is encouraged to try to correct the interference by one or more of the following measures: Reorient or relocate the receiving antenna, Increase the separation between the equipment and receiver, Connect the equipment into an outlet on a circuit different from that to which the receiver is connected. Consult the dealer or an experienced radio/TV technician for help. Note: Any changes or modifications to the transmitter or receiver not expressly approved by Hunter Fan Company may void one's authority to operate this remote control.