

Fan & Light Remote Control Transmitter Block Diagram

Description:

The top box of the diagram below represents all of the potential keys that may be pressed for the Hunter 85094 and 85095 remote transmitters. Pressing any key generates an encoded PCM code word which will modulate on a 350 MHz RF carrier for transmission. The encoded PCM code word is obtained from Microcontroller U1 and is ASK modulated by the RF oscillator formed by transistor Q3. Microcontroller U1 also provides four selectable security bits which can be set by the user. The frequency is formed by SAW resonator SAW1 to 350 MHz

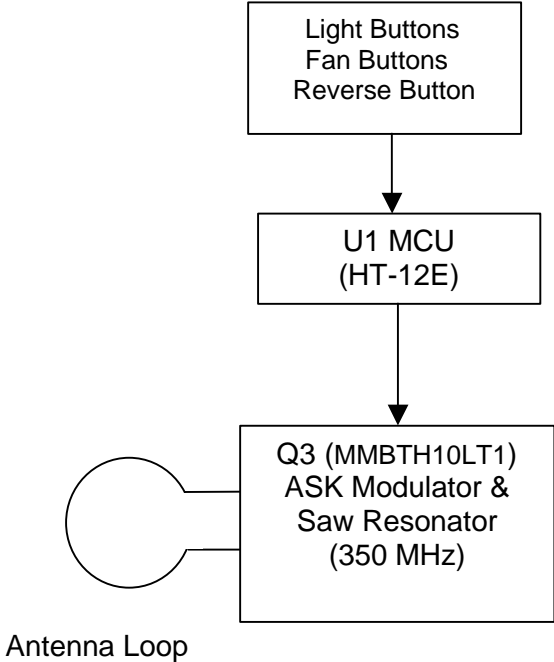

Fan & Light Remote Control RF Transmitter Coding

Description: The 85094 and 85095 transmitters use the following code words to modulate on a 350 MHz RF carrier by using ASK modulation.

Code words for the different commands:

- 1xxx0000101
 - 1xxx0001001
 - 1xxx0000110
 - 1xxx0000111
 - 1xxx0001000
 - 1xxx0001101
 - 1xxx0001110
- (Where "x" can be set to "1" or "0" by the user with DIP switches.)

Code "0" is represented as:

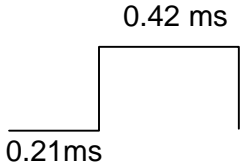

Code "1" is represented as:

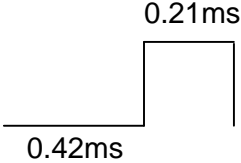

The interval between two code words is about 7.56 ms.

Fan & Light Remote Control Receiver Block Diagram

Description:

Refer to the block diagram of the Hunter 85068 and 85069 receiver below. Power is supplied to the receiving and control circuits through a 5-Volt regulator U2, which is not shown in the diagram. Transistor Q1 is the front amplifier to amplify the signal received from the monopole antenna. Transistor Q2 is the super-regenerative receiving stage, whose frequency can be factory tuned by coil L2. Op-Amp U1 is configured as the detector. Microcontroller U3 converts the PCM data signal and outputs 4 data bits to perform the desired actions to control the fan speed and light bulb brightness. Microcontroller U3 also provides four selectable security bits which can be set by the user and must match that of the hand-held remote transmitter to be a valid command.

