

DESCRIPTION WIRELESS LAN CARDBUS PCCARD IEEE802.11A/B/G

A. General

This document specifies an IEEE802.11a/b/g Wireless LAN Network Interface Card, with CardBus interface, based on the Agere WaveLAN 802.11a/b/g chipset solution. It operates in frequency bands 2.4 GHz and 5 GHz (see

Figure 1 shows the functional block diagram of the IEEE802.11a/b/g Network Interface PC Card based on the WaveLAN 802.11a/b/g Chipset. The seven main blocks are:

- WL60040, Wireless Medium Access Control (WMAC) processor
- off-the-shelf EEPROM
- WL64040, PHY (DSP)
- WL54040, 2.4GHz/5GHz dual-band integrated radio
- WL54240, dual-band PA (Power Amplifier)
- PSC0220, high performance supply and supply supervisor
- integrated antennas

The Physical layer (PHY) part consists of the DSP, Radio, PA, Supply, integrated antennae and EEPROM. Not shown on below block diagram are: the RF output power detector, RF filters and antenna switches.

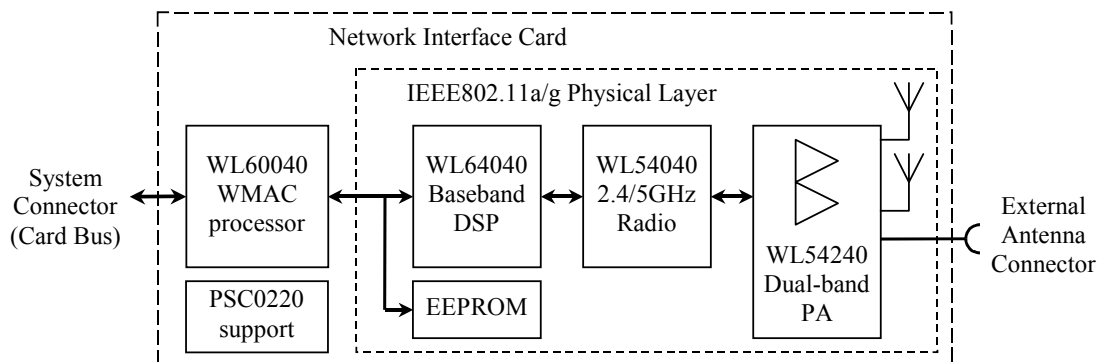

Figure 1: IEEE802.11a/b/g Network Interface CardBus PC Card architecture

The Network Interface Card is capable to transmit and receive from either of the two internal antennas. The Network Interface Card has an optional external antenna connector having 50Ω nominal port impedance with a maximum VSWR of 2:1 in the applied frequency bands. The internal antennae are disabled when a plug is mated on this connector.

B. Technical Characteristics:

1. Power supply: 3.3 Vdc

2. Technology and Data Rates:

- a. to IEEE 802.11b, 2.4 GHz band:
 - DSSS, at 1, 2, 5.5 and 11 Mbps
- b. to IEEE 802.11g, 2.4 GHz band:
 - OFDM, at 6, 9, 12, 18, 24, 36, 48, 54 Mbps
- c. to IEEE 802.11a, 5 GHz bands *:
 - OFDM, at 6, 9, 12, 18, 24, 36, 48, 54 Mbps

*: band and selection of channel in the band is determined by the band availability in the applicable country and by the operation mode; in ESS mode under control of an installed AccessPoint (AP) (in both 2.4 and 5 GHz bands) or in IBSS Mode where user has limited choice of band/channel (only in 2.4 GHz band!).

5 GHz Bands for this card include:

- 5150-5250 MHz
- 5150-5350 MHz
- 5725-5850 MHz

3. Output power *

using the integrated antennae (which have 0 dBi gain):

- 2400 to 2483.5 MHz: < 20 dBm e.i.r.p. maximum
- 5150 to 5350 MHz: <16 dBm e.i.r.p. max.
- 5470 to 5875 MHz: < 12 dBm e.i.r.p. max.

*: actual maximum levels are prepared in factory and can defer per region or country

4. Encryption: WEP or WPA

5 Standards:

- USA : FCC Part 15.247 and 15.407
- Canada: RSS 210-6.2.2