

SPECIFICATION

DESC	A0082022072301	Rev: A.1	CUST:	A008
			Fine P/N:	
			CUST P/N:	

1、DIMENSION:(mm)

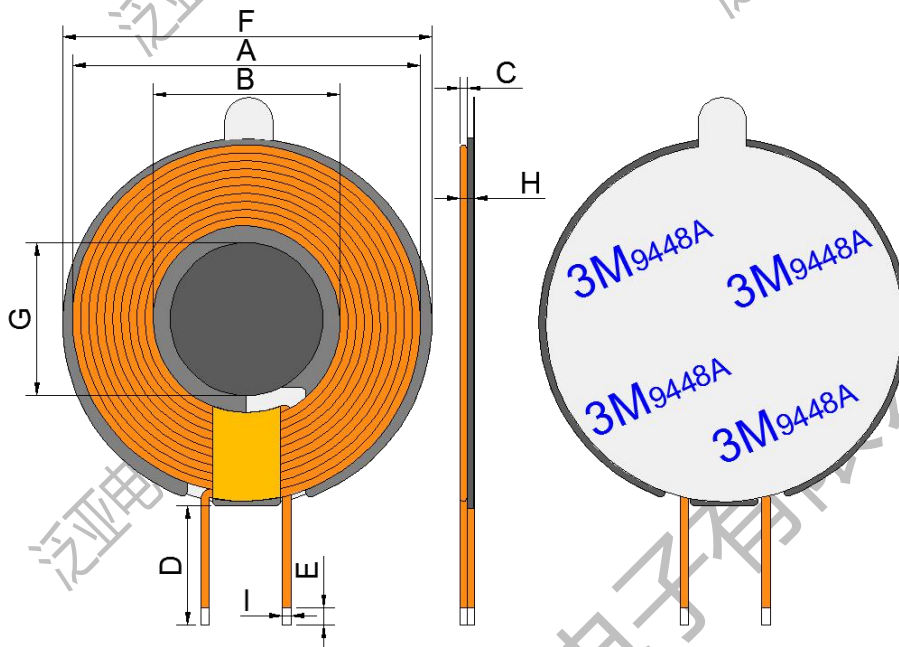

A	41±0.5
B	21.5±0.5
C	0.5 Max
D	8±1.5
E	1-3
F	43.5±0.5
G	18±0.5
H	1.8 Max (Excluding lead and unshaped paper)
I	1.5 MAX

Comments:

1. The coil is crossed out, Put up 8mm wide high-temperature adhesive on the outlet position;
2. Coil pastes on ferrite disc reversely, Hard magnetic sheet size ϕ 43.5mm*5*0.75mm, opening L double groove, convex column ϕ 18±0.5mm in the middle, thickness 0.5±0.1mm;
3. The back of the magnetic sheet is affixed with ϕ 42*0.15mm with hand tear position 3M9448A glue.
4. Starting line compression is not allowed.

2、SCHEMATIC DIAGRAM:

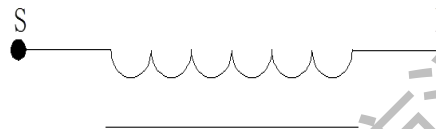

3、Winding Specification:

NO.	TERMINAL		WIRE	Turns	Winding Direction
1	S	F	Litz 0.08*45P	10Ts	CCW

4、ELECTRICAL CHARACTERISTICS:

TEMPERATURE:25±10°C, RELATIVE HUMIDITY:65±20%

NO.	ITEM	TERMINAL	SPECIFICATION	TEST FREQUENCY	TEST EQUIPMENTS
1	IND.	S-F	7.0uH ±10%	100KHz/1.0V	LCZ METER 1062B
2	DCR	S-F	≤100mΩ		TH2810

PREPARED BY/DATE	CHECKED BY/DATE
Huangxiaoyuan 2022/9/28	CAI jyu 2022/9/28