

FCC RADIO TEST REPORT

FCC ID: IKQBTFM5

Product : WIRELESS HANDS-FREE CAR KIT

Trade Mark: SCOSCHE

Model Name : BTFM5

Family Model : BTFM5-1

Report No. : S19051003102003

Prepared for

Scosche Industries Inc

1550 Pacific Ave, Oxnard CA 93033 USA

Prepared by

Shenzhen NTEK Testing Technology Co., Ltd.

1/F, Building E, Fenda Science Park, Sanwei Community,
Xixiang Street Bao'an District, Shenzhen 518126 P.R. China

Tel.: +86-755-6115 6588

Fax.: +86-755-6115 6599

Website: <http://www.ntek.org.cn>

TEST RESULT CERTIFICATION

Applicant's name : Scosche Industries Inc
Address : 1550 Pacific Ave, Oxnard CA 93033 USA
Manufacture's Name : Scosche Industries Inc
Address : 1550 Pacific Ave, Oxnard CA 93033 USA

Product description

Product name : WIRELESS HANDS-FREE CAR KIT
Model and/or type reference : BTFM5
Family Model : BTFM5-1
Rating(s) : DC 12-24V

Standards : FCC 47 CFR Part 15, Subpart C §15.239

Test procedure : ANSI C63.10-2013

This device described above has been tested by NTEK, and the test results show that the equipment under test (EUT) is in compliance with the FCC requirements. And it is applicable only to the tested sample identified in the report.

This report shall not be reproduced except in full, without the written approval of NTEK, this document may be altered or revised by NTEK, personal only, and shall be noted in the revision of the document.

Date of Test :
Date (s) of performance of tests : May. 27, 2019 ~ Jun. 18, 2019
Date of Issue : Jun. 21, 2019
Test Result : Pass

Testing Engineer : [Signature]
(Mary Hu)

Technical Manager : [Signature]
(Jason Chen)

Authorized Signatory : [Signature]
(Sam Chen)

Table of Contents

Page

1 . SUMMARY OF TEST RESULTS	4
1.1 TEST FACILITY	5
1.2 MEASUREMENT UNCERTAINTY	5
2 . GENERAL INFORMATION	6
2.1 GENERAL DESCRIPTION OF EUT	6
2.2 DESCRIPTION OF TEST MODES	7
2.3 BLOCK DIGRAM SHOWING THE CONFIGURATION OF SYSTEM TESTED	8
2.4 DESCRIPTION OF SUPPORT UNITS(CONDUCTED MODE)	9
2.5 EQUIPMENTS LIST FOR ALL TEST ITEMS	10
3 . ANTENNA REQUIREMENT	11
3.1 STANDARD REQUIREMENT	11
3.2 EUT ANTENNA	11
3.3 CONDUCTED EMISSION MEASUREMENT	11
3.3.1 POWER LINE CONDUCTED EMISSION LIMITS	12
3.3.2 TEST PROCEDURE	12
3.3.3 DEVIATION FROM TEST STANDARD	12
3.3.4 TEST SETUP	12
3.2.5 TEST RESULT	14
3.4 RADIATED EMISSION MEASUREMENT	18
3.4.1 RADIATED EMISSION LIMITS	18
3.4.2 TEST PROCEDURE	19
3.4.3 DEVIATION FROM TEST STANDARD	19
3.4.4 TEST SETUP	20
3.4.5 TEST RESULTS (BLOW 30MHZ)	21
3.4.6 TEST RESULTS (BETWEEN 30 – 1000 MHZ)	22
3.4.7 TEST RESULTS (BAND EDGE EMISSION)	28
4 . BANDWIDTH TEST	32
4.1 TEST PROCEDURE	32
4.2 DEVIATION FROM STANDARD	32
4.3 TEST SETUP	32
4.4 TEST RESULTS	33
APPENDIX-PHOTOGRAPHS OF EUT CONSTRUCTIONAL DETAILS	

1. SUMMARY OF TEST RESULTS

Test procedures according to the technical standards:

FCC Part15, Subpart C (15.239)			
Standard Section	Test Item	Judgment	Remark
15.207	Conducted Emission	Pass	
15.203	Antenna Requirement	Pass	
15.239	Radiated Spurious Emission	Pass	
15.239	Occupied Bandwidth	Pass	
15.205 15.239	Spurious Emission in Restricted Band	Pass	

1.1 TEST FACILITY

NTEK Testing Technology Co., Ltd
 Add. : 1/F, Building E, Fenda Science Park, Sanwei Community, Xixiang Street, Bao'an District, Shenzhen P.R. China.
 FCC FRN Registration No.: 463705; IC Registration No.:9270A-1
 CNAS Registration No.:L5516

1.2 MEASUREMENT UNCERTAINTY

The reported uncertainty of measurement $y \pm U$, where expanded uncertainty U is based on a standard uncertainty multiplied by a coverage factor of $k=2$, providing a level of confidence of approximately 95 %.

No.	Item	Uncertainty
1	Conducted Emission Test	$\pm 1.38\text{dB}$
2	RF power,conducted	$\pm 0.16\text{dB}$
3	Spurious emissions,conducted	$\pm 0.21\text{dB}$
4	All emissions,radiated(<1G)	$\pm 4.68\text{dB}$
5	All emissions,radiated(>1G)	$\pm 4.89\text{dB}$
6	Temperature	$\pm 0.5^\circ\text{C}$
7	Humidity	$\pm 2\%$

2. GENERAL INFORMATION

2.1 GENERAL DESCRIPTION OF EUT

Equipment	WIRELESS HANDS-FREE CAR KIT	
Trade Name	SCOSCHE	
Model Name	BTFM5	
Family Model	BTFM5-1	
Model Difference	All models are the same circuit and RF module, except the packaging.	
Product Description	The EUT is a WIRELESS HANDS-FREE CAR KIT	
	Product Type	Low Power Communication Device Transmitter
	Operation Frequency:	88.1-107.9MHz
	Modulation Type:	FM
	Number Of Channel	199CH.
	Antenna Designation:	Spring Antenna
	Antenna Gain(Peak)	0.5 dBi
Field Strength:	44.67 dBuV/m	
Power supply	<input checked="" type="checkbox"/> DC supply: DC 12-24V, 3A	
	<input type="checkbox"/> Adapter supply:	
Battery	N/A	
Hard Ware Version	1.0	
Soft Ware Version	1.0	

Note:

1. For a more detailed features description, please refer to the manufacturer's specifications or the User's Manual.

2.2 DESCRIPTION OF TEST MODES

To investigate the maximum EMI emission characteristics generates from EUT, the test system was pre-scanning tested base on the consideration of following EUT operation mode or test configuration mode which possible have effect on EMI emission level. Each of these EUT operation mode(s) or test configuration mode(s) mentioned above was evaluated respectively.

Carrier Frequency and Channel list:

Channel	Frequency(MHz)
0	88.1
1	88.2
...	...
99	98.1
100	98.2
...	...
197	107.8
198	107.9

Note: $f_c=88.1\text{MHz}+k \times 0.1\text{MHz}$ $k=0$ to 198

Pretest Mode	Description
Mode 1	88.1MHz
Mode 2	98.1MHz
Mode 3	107.9MHz

For Conducted Emission	
Final Test Mode	Description
Mode 1	88.1MHz

Note: Three kinds of frequency (88.1MHz, 98.1MHz, 107.9MHz) has been tested, but and the worst result was report.

For Radiated Emission	
Final Test Mode	Description
Mode 1	88.1MHz
Mode 2	98.1MHz
Mode 3	107.9MHz

Note:

- (1) The measurements are performed at the highest, middle, lowest available channels.
- (2) During testing, the EUT was actively playing music set to its maximum audio volume in order to generate the worst case emissions (e.g. to generate the maximum bandwidth during bandwidth test). No test tones were used for testing. The tuning range of the EUT was manually verified and the conclusion is that it only works at selected channels within 88.1-107.9MHz, not below and not above this range.

2.3 BLOCK DIGRAM SHOWING THE CONFIGURATION OF SYSTEM TESTED

For AC Conducted Emission Mode

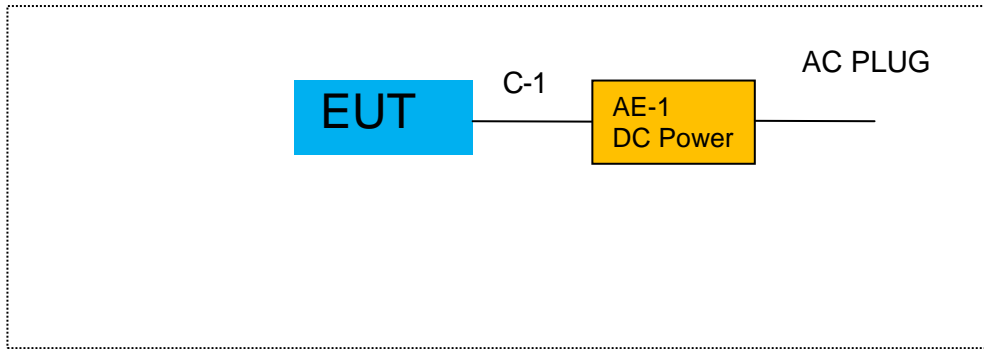

For Radiated Test Cases

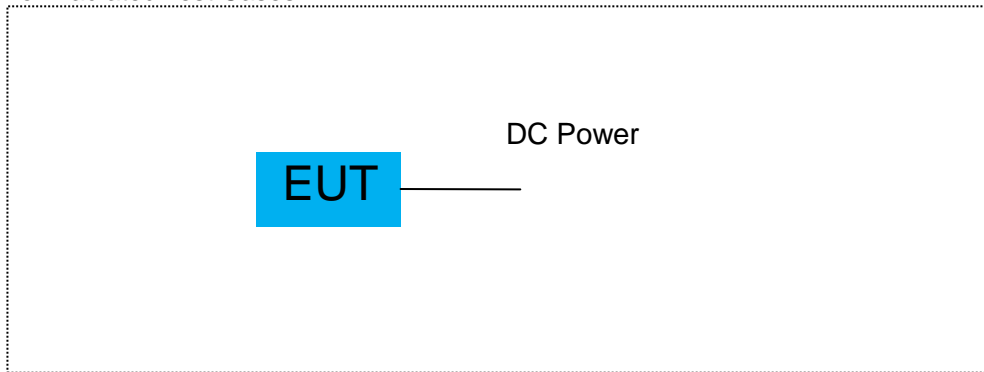

For Conducted Test Cases

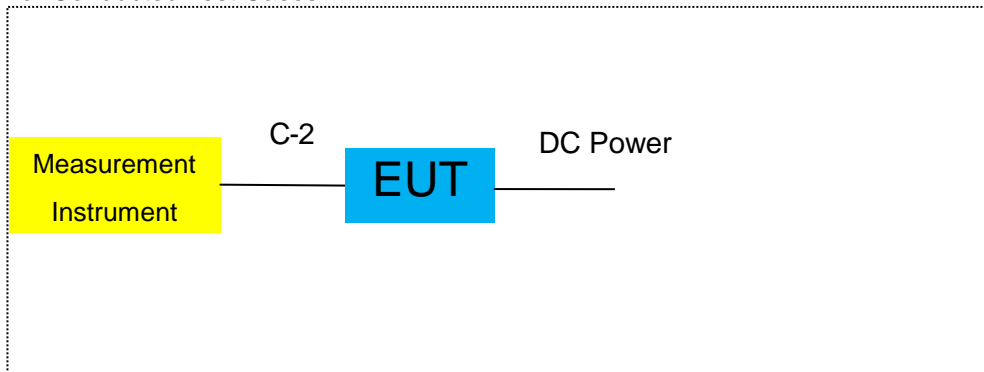

Note: The temporary antenna connector is soldered on the PCB board in order to perform conducted tests and this temporary antenna connector is listed in the equipment list.

2.4 DESCRIPTION OF SUPPORT UNITS(CONDUCTED MODE)

The EUT has been tested as an independent unit together with other necessary accessories or support units. The following support units or accessories were used to form a representative test configuration during the tests.

Item	Equipment	Mfr/Brand	Model/Type No.	Series No.	Note
AE-1	DC Power	N/A	N/A	N/A	Peripherals

Item	Shielded Type	Ferrite Core	Length	Note
C-1	DC Cable	NO	NO	0.5m
C-2	RF Cable	YES	NO	0.1m

Note:

- (1) The support equipment was authorized by Declaration of Confirmation.
- (2) For detachable type I/O cable should be specified the length in cm in 『Length』 column.

2.5 EQUIPMENTS LIST FOR ALL TEST ITEMS

Radiation& Conducted Test equipment

	Kind of Equipment	Manufacturer	Type No.	Serial No.	Last calibration	Calibrated until	Calibration period
1	Spectrum Analyzer	Agilent	N9020A	MY49100060	2019.05.13	2020.05.12	1 year
2	Test Receiver	R&S	ESPI	101318	2019.05.13	2020.05.12	1 year
3	Bilog Antenna	TESEQ	CBL6111D	31216	2019.04.15	2020.04.14	1 year
4	50Ω Coaxial Switch	Anritsu	MP59B	6200983705	2018.05.19	2020.05.18	1 year
5	Horn Antenna	EM	EM-AH-1018 0	2011071402	2019.04.15	2020.04.14	1 year
6	Amplifier	EMC	EMC051835 SE	980246	2018.08.05	2019.08.04	1 year
7	Test Cable (9KHz-30MHz)	N/A	R-01	N/A	2017.04.21	2020.04.20	3 year
8	Test Cable (30MHz-1GHz)	N/A	R-02	N/A	2017.04.21	2020.04.20	3 year
9	temporary antenna connector (Note)	NTS	R001	N/A	N/A	N/A	N/A

AC Conduction Test equipment

Item	Kind of Equipment	Manufacturer	Type No.	Serial No.	Last calibration	Calibrated until	Calibration period
1	Test Receiver	R&S	ESCI	101160	2019.05.13	2020.05.12	1 year
2	LISN	R&S	ENV216	101313	2019.04.15	2020.04.14	1 year
3	LISN	SCHWARZBECK	NNLK 8129	8129245	2019.05.13	2020.05.12	1 year
4	50Ω Coaxial Switch	ANRITSU CORP	MP59B	6200983704	2018.05.19	2020.05.18	2 year
5	Test Cable (9KHz-30MHz)	N/A	C01	N/A	2017.04.21	2020.04.20	3 year
6	Test Cable (9KHz-30MHz)	N/A	C02	N/A	2017.04.21	2020.04.20	3 year
7	Test Cable (9KHz-30MHz)	N/A	C03	N/A	2017.04.21	2020.04.20	3 year

Note: Each piece of equipment is scheduled for calibration once a year except the Aux Equipment & Test Cable which is scheduled for calibration every 2 or 3 years.

3. ANTENNA REQUIREMENT

3.1 STANDARD REQUIREMENT

15.203 requirement: For intentional device, according to 15.203: an intentional radiator shall be designed to ensure that no antenna other than that furnished by the responsible party shall be used with the device.

3.2 EUT ANTENNA

The EUT antenna is permanent attached spring antenna. It comply with the standard requirement.

3.3 CONDUCTED EMISSION MEASUREMENT

3.3.1 POWER LINE CONDUCTED EMISSION Limits (Frequency Range 150KHz-30MHz)

Frequency(MHz)	Conducted Emission Limit	
	Quasi-peak	Average
0.15-0.5	66-56*	56-46*
0.5-5.0	56	46
5.0-30.0	60	50

Note: 1. *Decreases with the logarithm of the frequency
 2. The lower limit shall apply at the transition frequencies
 3. The limit decreases in line with the logarithm of the frequency in the range of 0.15 to 0.50MHz.

The following table is the setting of the receiver

Receiver Parameters	Setting
Attenuation	10 dB
Start Frequency	0.15 MHz
Stop Frequency	30 MHz
IF Bandwidth	9 kHz

3.3.2 TEST PROCEDURE

- a. The EUT was placed 0.4 meters from the horizontal ground plane with EUT being connected to the power mains through a line impedance stabilization network (LISN). All other support equipments powered from additional LISN(s). The LISN provide 50 Ohm/ 50uH of coupling impedance for the measuring instrument.
- b. Interconnecting cables that hang closer than 40 cm to the ground plane shall be folded back and forth in the center forming a bundle 30 to 40 cm long.
- c. I/O cables that are not connected to a peripheral shall be bundled in the center. The end of the cable may be terminated, if required, using the correct terminating impedance. The overall length shall not exceed 1 m.
- d. LISN at least 80 cm from nearest part of EUT chassis.
- e. For the actual test configuration, please refer to the related Item –EUT Test Photos.

3.3.3 DEVIATION FROM TEST STANDARD

No deviation

3.3.4 TEST SETUP

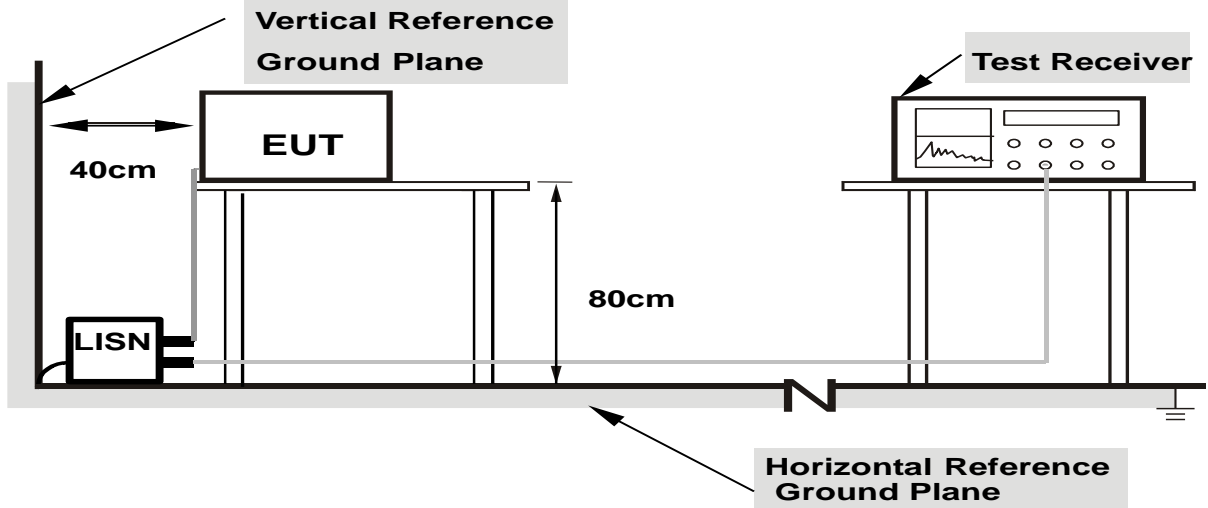

- Note:**
1. Support units were connected to second LISN.
 2. Both of LISNs (AMN) are 80 cm from EUT and at least 80 from other units and other metal planes

3.2.5 TEST RESULT

EUT :	WIRELESS HANDS-FREE CAR KIT	Model Name. :	BTFM5
Temperature :	26 °C	Relative Humidity :	54%
Pressure :	1010hPa	Phase :	N
Test Voltage :	DC 12V from DC Power AC 120V/60Hz	Test Mode :	Mode 1

Frequency (MHz)	Reading Level (dBμV)	Correct Factor (dB)	Measure-ment (dBμV)	Limits (dBμV)	Margin (dB)	Remark
0.1620	28.98	9.76	38.74	65.36	-26.62	QP
0.1620	3.57	9.76	13.33	55.36	-42.03	AVG
0.3580	24.95	9.74	34.69	58.77	-24.08	QP
0.3580	-0.46	9.74	9.28	48.77	-39.49	AVG
0.4540	23.80	9.74	33.54	56.80	-23.26	QP
0.4540	-0.58	9.74	9.16	46.80	-37.64	AVG
1.4500	18.85	9.76	28.61	56.00	-27.39	QP
1.4500	1.03	9.76	10.79	46.00	-35.21	AVG
17.9739	23.09	10.17	33.26	60.00	-26.74	QP
17.9739	15.63	10.17	25.80	50.00	-24.20	AVG
24.2380	31.68	10.65	42.33	60.00	-17.67	QP
24.2380	30.50	10.65	41.15	50.00	-8.85	AVG

Remark:

1. All readings are Quasi-Peak and Average values.
2. Factor = Insertion Loss + Cable Loss.

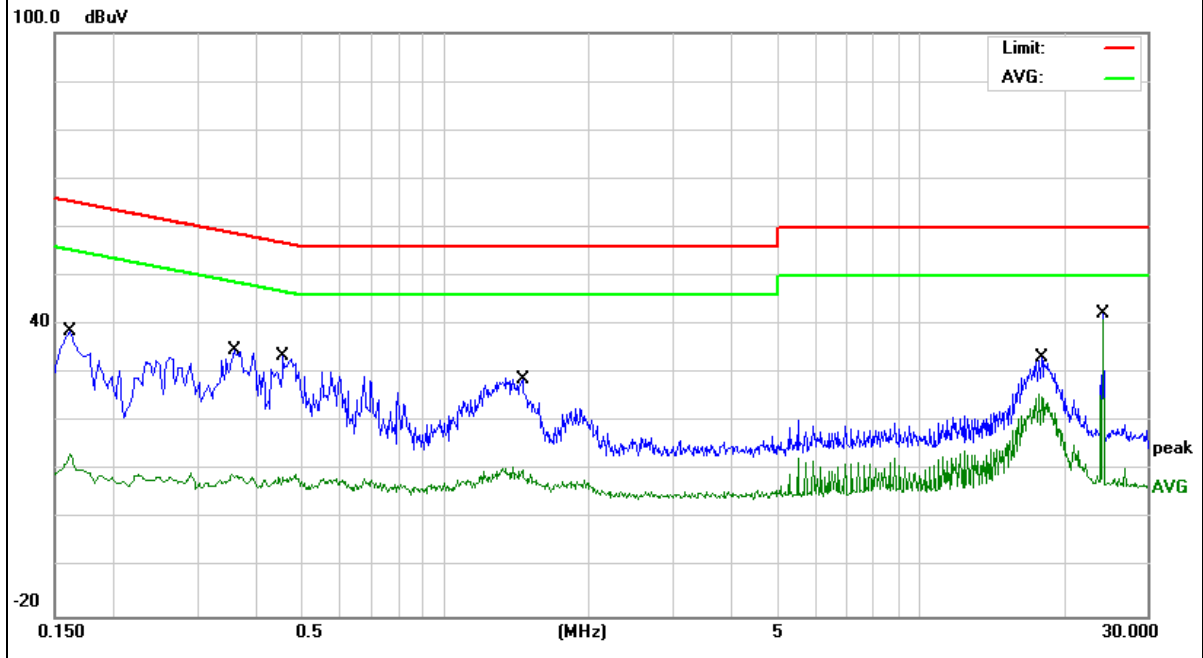

EUT :	WIRELESS HANDS-FREE CAR KIT	Model Name :	BTFM5
Temperature :	26 °C	Relative Humidity :	54%
Pressure :	1010hPa	Phase :	N
Test Voltage :	DC 12V from DC Power AC 120V/60Hz	Test Mode :	Mode 1

Frequency (MHz)	Reading Level (dBμV)	Correct Factor (dB)	Measurement (dBμV)	Limits (dBμV)	Margin (dB)	Remark
0.2500	23.61	9.74	33.35	61.75	-28.40	QP
0.2500	1.45	9.74	11.19	51.75	-40.56	AVG
0.3540	25.42	9.75	35.17	58.87	-23.70	QP
0.3540	2.85	9.75	12.60	48.87	-36.27	AVG
0.4660	24.04	9.75	33.79	56.58	-22.79	QP
0.4660	1.26	9.75	11.01	46.58	-35.57	AVG
1.3180	19.64	9.76	29.40	56.00	-26.60	QP
1.3180	0.90	9.76	10.66	46.00	-35.34	AVG
18.0059	23.53	10.16	33.69	60.00	-26.31	QP
18.0059	15.06	10.16	25.22	50.00	-24.78	AVG
24.2340	31.56	10.59	42.15	60.00	-17.85	QP
24.2340	30.63	10.59	41.22	50.00	-8.78	AVG

Remark:

1. All readings are Quasi-Peak and Average values.
2. Factor = Insertion Loss + Cable Loss.

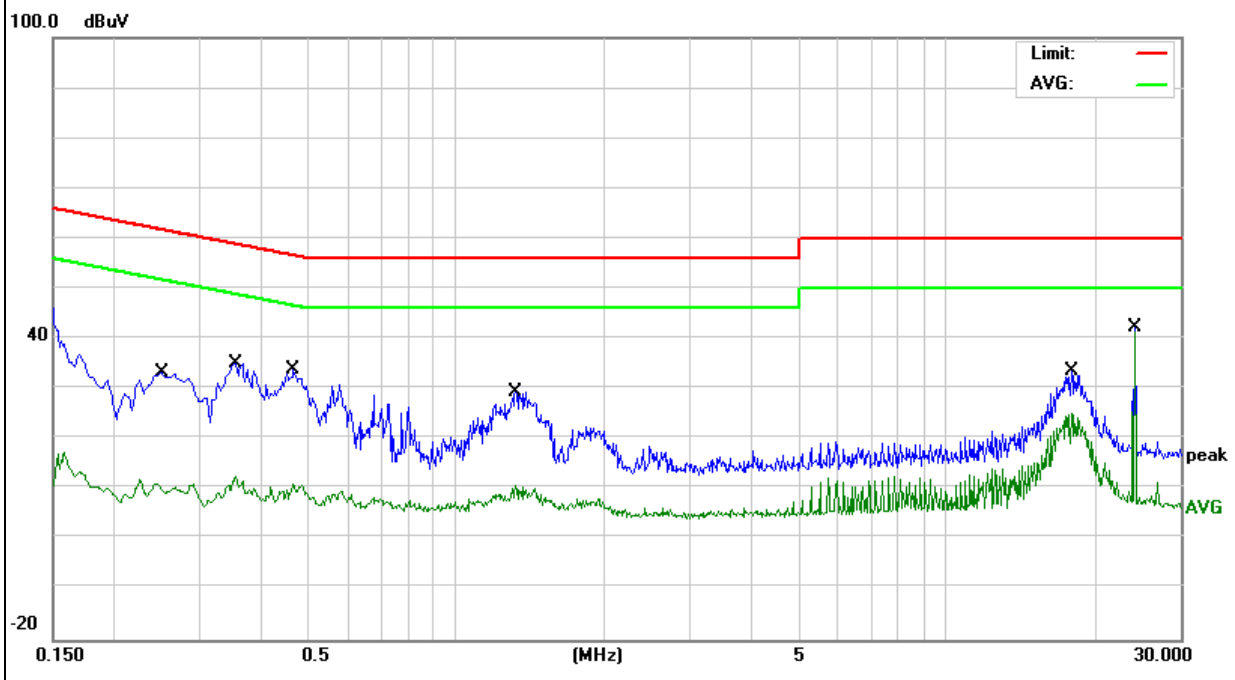

EUT :	WIRELESS HANDS-FREE CAR KIT	Model Name :	BTFM5
Temperature :	26 °C	Relative Humidity :	54%
Pressure :	1010hPa	Phase :	L
Test Voltage :	DC 12V from DC Power AC 240V/60Hz	Test Mode :	Mode 1

Frequency (MHz)	Reading Level (dBμV)	Correct Factor (dB)	Measure-ment (dBμV)	Limits (dBμV)	Margin (dB)	Remark
0.2660	26.31	9.75	36.06	61.24	-25.18	QP
0.2660	1.76	9.75	11.51	51.24	-39.73	AVG
0.3618	25.56	9.74	35.30	58.69	-23.39	QP
0.3618	0.36	9.74	10.10	48.69	-38.59	AVG
0.4580	25.64	9.74	35.38	56.73	-21.35	QP
0.4580	0.60	9.74	10.34	46.73	-36.39	AVG
1.3938	20.66	9.75	30.41	56.00	-25.59	QP
1.3938	1.38	9.75	11.13	46.00	-34.87	AVG
18.8978	22.91	10.20	33.11	60.00	-26.89	QP
18.8978	15.28	10.20	25.48	50.00	-24.52	AVG
24.2377	30.07	10.65	40.72	60.00	-19.28	QP
24.2377	28.94	10.65	39.59	50.00	-10.41	AVG

Remark:

1. All readings are Quasi-Peak and Average values.
2. Factor = Insertion Loss + Cable Loss.

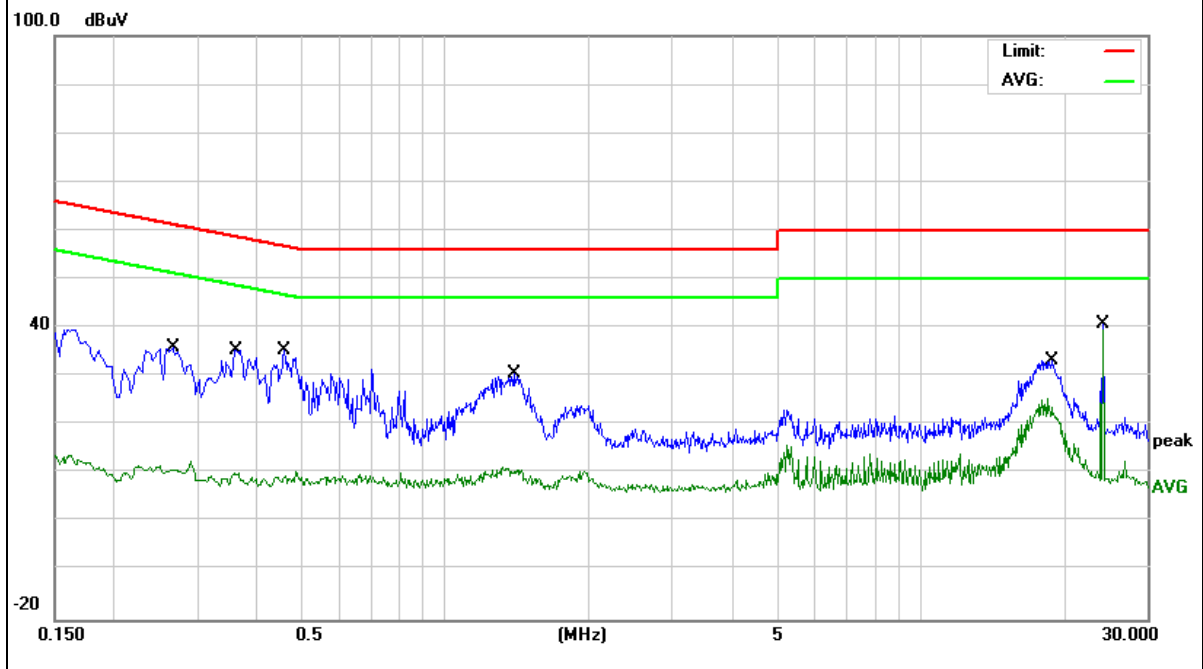

EUT :	WIRELESS HANDS-FREE CAR KIT	Model Name :	BTFM5
-------	-----------------------------	--------------	-------

Temperature :	26 °C	Relative Humidity :	54%
Pressure :	1010hPa	Phase :	N
Test Voltage :	DC 12V from DC Power AC 240V/60Hz	Test Mode :	Mode 1

Frequency (MHz)	Reading Level (dBμV)	Correct Factor (dB)	Measure-ment (dBμV)	Limits (dBμV)	Margin (dB)	Remark
0.2540	27.28	9.76	37.04	61.62	-24.58	QP
0.2540	2.54	9.76	12.30	51.62	-39.32	AVG
0.3497	28.33	9.73	38.06	58.97	-20.91	QP
0.3497	2.00	9.73	11.73	48.97	-37.24	AVG
0.4500	26.18	9.74	35.92	56.87	-20.95	QP
0.4500	1.79	9.74	11.53	46.87	-35.34	AVG
1.3855	21.86	9.75	31.61	56.00	-24.39	QP
1.3855	2.76	9.75	12.51	46.00	-33.49	AVG
18.4539	25.22	10.18	35.40	60.00	-24.60	QP
18.4539	16.53	10.18	26.71	50.00	-23.29	AVG
24.2377	29.68	10.65	40.33	60.00	-19.67	QP
24.2377	28.81	10.65	39.46	50.00	-10.54	AVG

Remark:

1. All readings are Quasi-Peak and Average values.
2. Factor = Insertion Loss + Cable Loss.

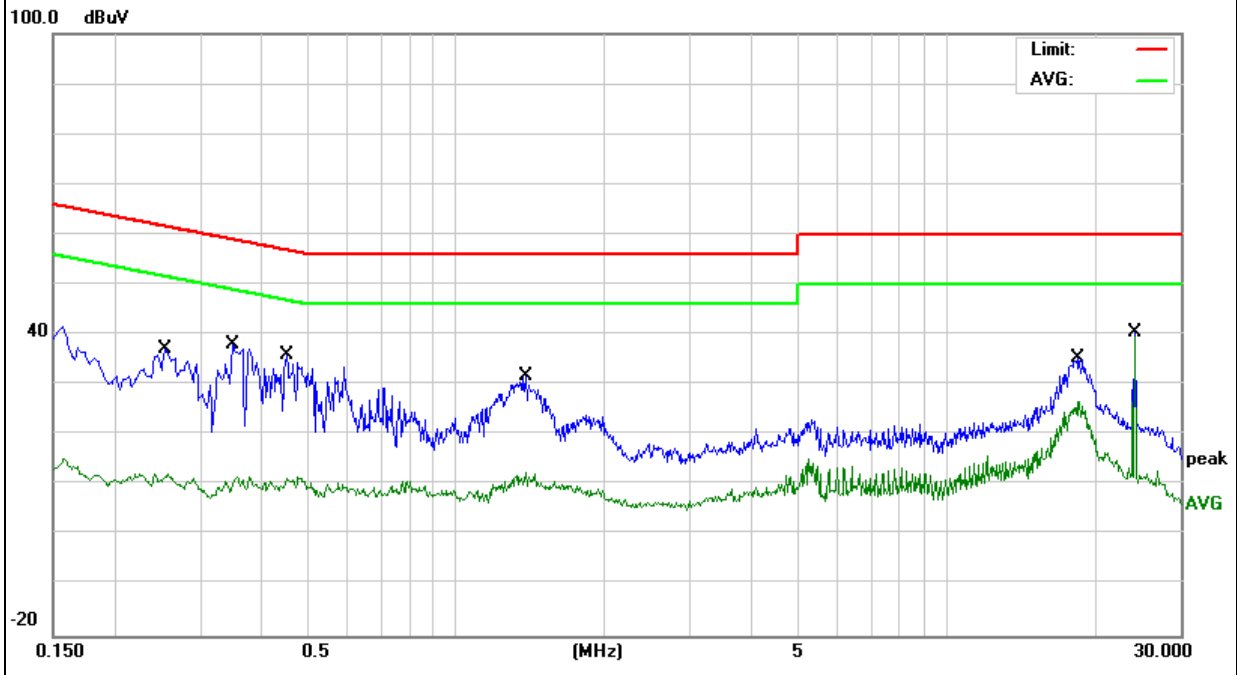

3.4 RADIATED EMISSION MEASUREMENT

3.4.1 Radiated Emission Limits (FCC 15.209)

Frequencies (MHz)	Field Strength (micorvolts/meter)	Measurement Distance (meters)
0.009~0.490	2400/F(KHz)	300
0.490~1.705	24000/F(KHz)	30
1.705~30.0	30	30
30~88	100	3
88~216	150	3
216~960	200	3
Above 960	500	3

Note:

- (1) The tighter limit applies at the band edges.
- (2) Emission level (dBuV/m)=20log Emission level (uV/m).

LIMITS OF RADIATED EMISSION MEASUREMENT (FCC 15.239)

Frequency of Emission (MHz)	Field Strength of fundamental (dBµV/m)	
	Peak	AVG
88-108	68	48

Notes:

- (1) Fcc part15.239 (b) The field strength of any emissions within the permitted 200 kHz band shall not exceed 250 microvolts/meter at 3 meters. The emission limit in this paragraph is based on measurement instrumentation employing an average detector. The provisions in Section 15.35 for limiting peak emissions apply.

Spectrum Parameter	Setting
Attenuation	Auto
Start Frequency	1000 MHz
Stop Frequency	10th carrier harmonic
RB / VB (emission in restricted band)	1MHz / 1MHz for Peak

Receiver Parameter	Setting
Attenuation	Auto
Start ~ Stop Frequency	9kHz~150kHz / RB 200Hz for QP
Start ~ Stop Frequency	150kHz~30MHz / RB 9kHz for QP
Start ~ Stop Frequency	30MHz~1000MHz / RB 120kHz for QP

3.4.2 TEST PROCEDURE

- a. The measuring distance of at 3 m shall be used for measurements at frequency up to 1GHz. For frequencies above 1GHz, any suitable measuring distance may be used.
- b. The EUT was placed on the top of a rotating table 0.8 meters above the ground at a 3m meter open area test site. The table was rotated 360 degrees to determine the position of the highest radiation.
- c. The height of the equipment or of the substitution antenna shall be 0.8 m; the height of the test antenna shall vary between 1 m to 4 m.
- d. The initial step in collecting conducted emission data is a spectrum analyzer peak detector mode pre-scanning the measurement frequency range. Significant peaks are then marked and then Quasi Peak detector mode re-measured.
- e. If the Peak Mode measured value compliance with and lower than Quasi Peak Mode Limit, the EUT shall be deemed to meet QP Limits and then no additional QP Mode measurement performed.
- f. For the actual test configuration, please refer to the related Item –EUT Test Photos.

Note:

Both horizontal and vertical antenna polarities were tested and performed pretest to three orthogonal axis. The worst case emissions were reported

3.4.3 DEVIATION FROM TEST STANDARD

No deviation

3.4.4 TEST SETUP

(a) For radiated emissions below 30MHz

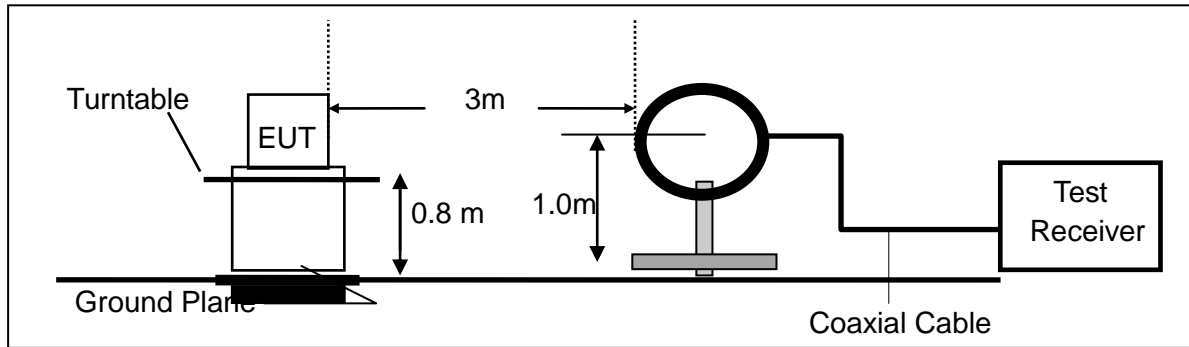

(b) For radiated emissions from 30MHz to 1000MHz

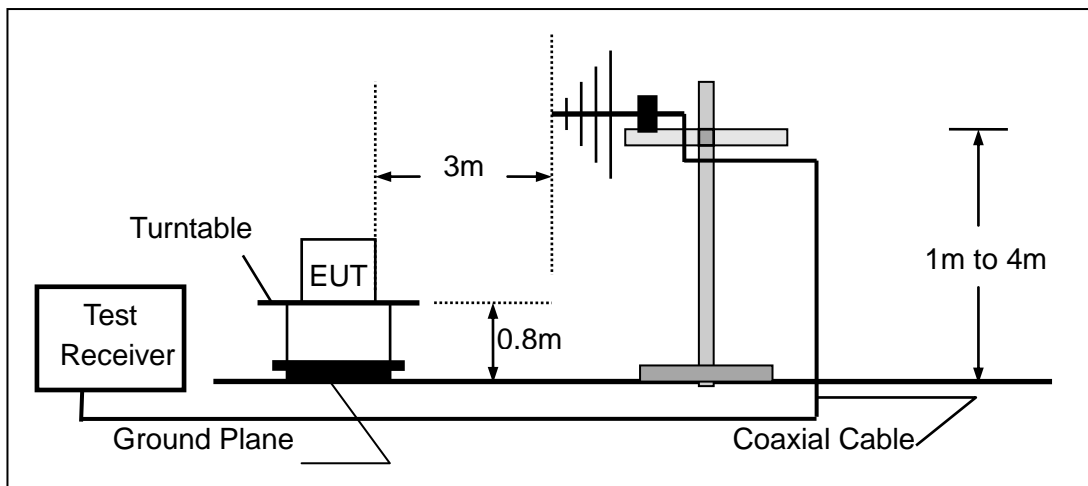

(c) For radiated emissions above 1000MHz

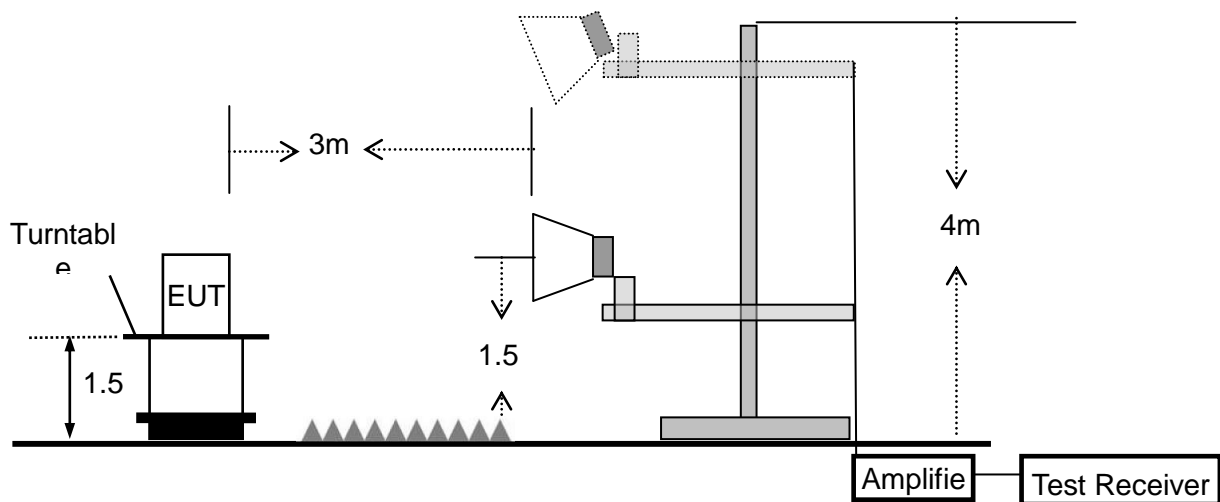

3.4.5 TEST RESULTS (BLOW 30MHz)

EUT :	WIRELESS HANDS-FREE CAR KIT	Model Name. :	BTFM5
Temperature :	20 °C	Relative Humidity :	48%
Pressure :	1010 hPa	Test Voltage :	DC 12.0V
Test Mode :	TX	Polarization :	--

Freq. (MHz)	Reading (dBuV/m)	Limit (dBuV/m)	Margin (dB)	State P/F
--	--	--	--	PASS
--	--	--	--	PASS

Note: the amplitude of spurious emission that is attenuated by more than 20dB below the permissible limit has no need to be reported.

3.4.6 TEST RESULTS (BETWEEN 30 – 1000 MHZ)

EUT :	WIRELESS HANDS-FREE CAR KIT	Model Name :	BTFM5
Temperature :	20 °C	Relative Humidity :	48%
Pressure :	1010 hPa	Test Voltage :	DC 12.0V
Test Mode :	88.1MHz	Polarization :	Vertical

Frequency (MHz)	Meter Reading (dBμV)	Factor (dB)	Emission Level (dBμV/m)	Limits (dBμV/m)	Margin (dB)	Remark
47.9940	20.52	11.33	31.85	40.00	-8.15	QP
59.8588	27.91	6.50	34.41	40.00	-5.59	QP
88.0327	38.95	9.96	48.91	68.00	-19.09	peak
88.0327	34.71	9.96	44.67	48.00	-3.33	AVG
157.5588	17.22	12.03	29.25	43.50	-14.25	QP
187.0958	19.16	10.53	29.69	43.50	-13.81	QP
215.2677	16.79	10.90	27.69	43.50	-15.81	QP

Remark:

1. Factor = Antenna Factor + Cable Loss – Pre-amplifier.

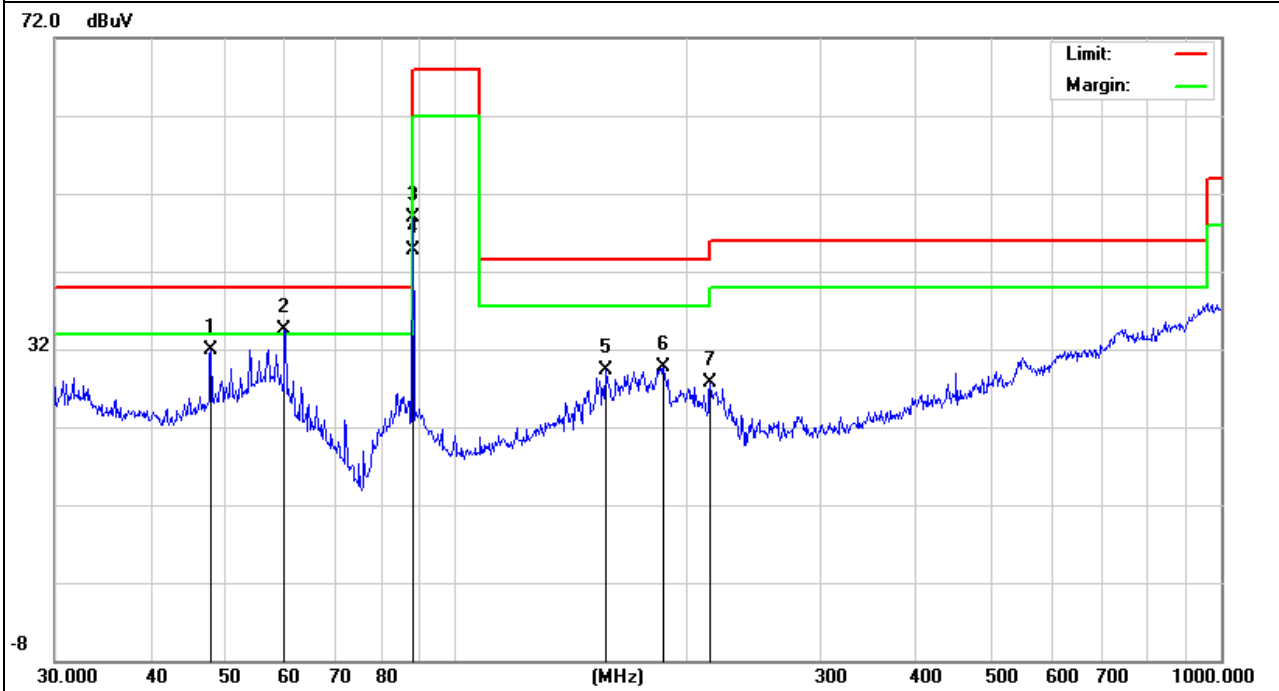

EUT :	WIRELESS HANDS-FREE CAR KIT	Model Name :	BTFM5
Temperature :	20 °C	Relative Humidity :	48%
Pressure :	1010 hPa	Test Voltage :	DC 12.0V
Test Mode :	88.1MHz	Polarization :	Horizontal

Frequency (MHz)	Meter Reading (dBμV)	Factor (dB)	Emission Level (dBμV/m)	Limits (dBμV/m)	Margin (dB)	Remark
59.8588	24.91	6.50	31.41	40.00	-8.59	QP
88.0327	38.71	9.96	48.67	68.00	-19.33	peak
88.0327	33.25	9.96	43.21	48.00	-4.79	AVG
191.7450	25.77	10.07	35.84	43.50	-7.66	QP
224.5192	16.42	12.00	28.42	46.00	-17.58	QP
485.6093	10.65	21.53	32.18	46.00	-13.82	QP
750.1082	7.24	27.47	34.71	46.00	-11.29	QP

Remark:

- Factor = Antenna Factor + Cable Loss – Pre-amplifier.

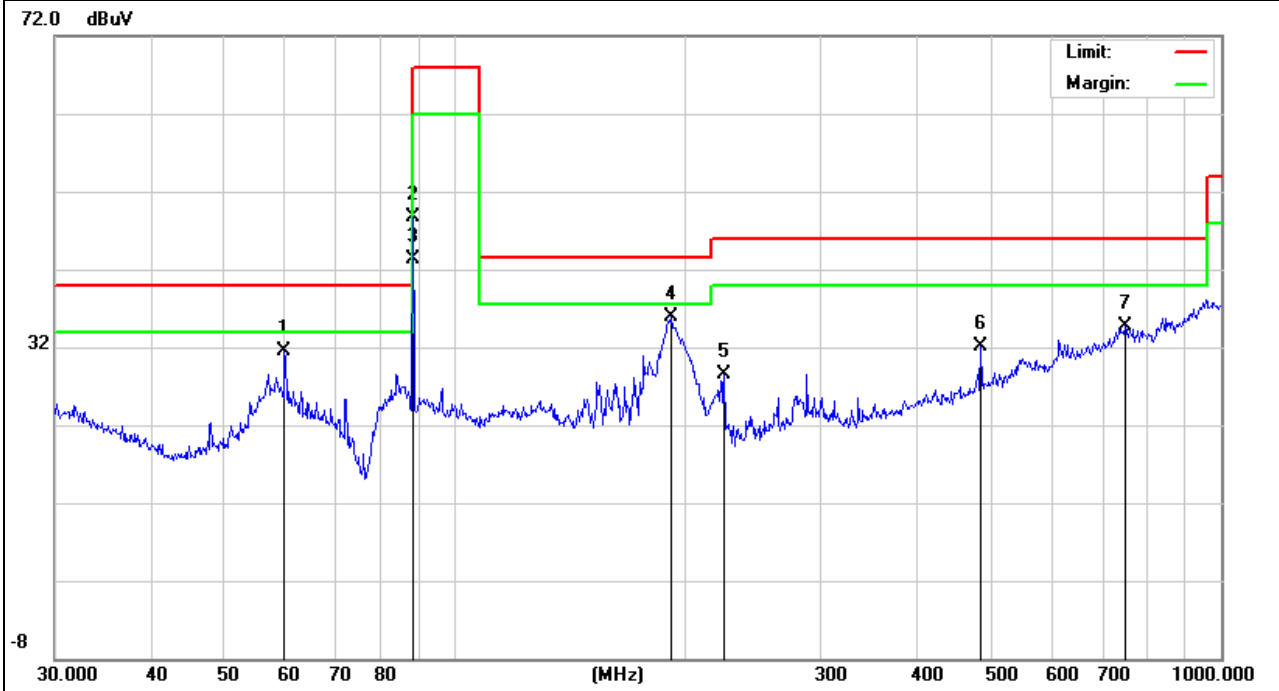

EUT :	WIRELESS HANDS-FREE CAR KIT	Model Name :	BTFM5
Temperature :	20 °C	Relative Humidity :	48%
Pressure :	1010 hPa	Test Voltage :	DC 12.0V
Test Mode :	98.1MHz	Polarization :	Vertical

Frequency (MHz)	Meter Reading (dBμV)	Factor (dB)	Emission Level (dBμV/m)	Limits (dBμV/m)	Margin (dB)	Remark
31.0703	10.78	18.52	29.30	40.00	-10.70	QP
47.9938	18.41	11.33	29.74	40.00	-10.26	QP
59.8588	26.39	6.50	32.89	40.00	-7.11	QP
98.1419	24.58	11.32	35.90	68.00	-32.10	peak
98.1419	28.89	11.32	40.21	48.00	-7.79	AVG
189.0743	23.06	10.30	33.36	43.50	-10.14	QP
622.8900	6.86	24.80	31.66	46.00	-14.34	QP

Remark:

1. Factor = Antenna Factor + Cable Loss – Pre-amplifier.

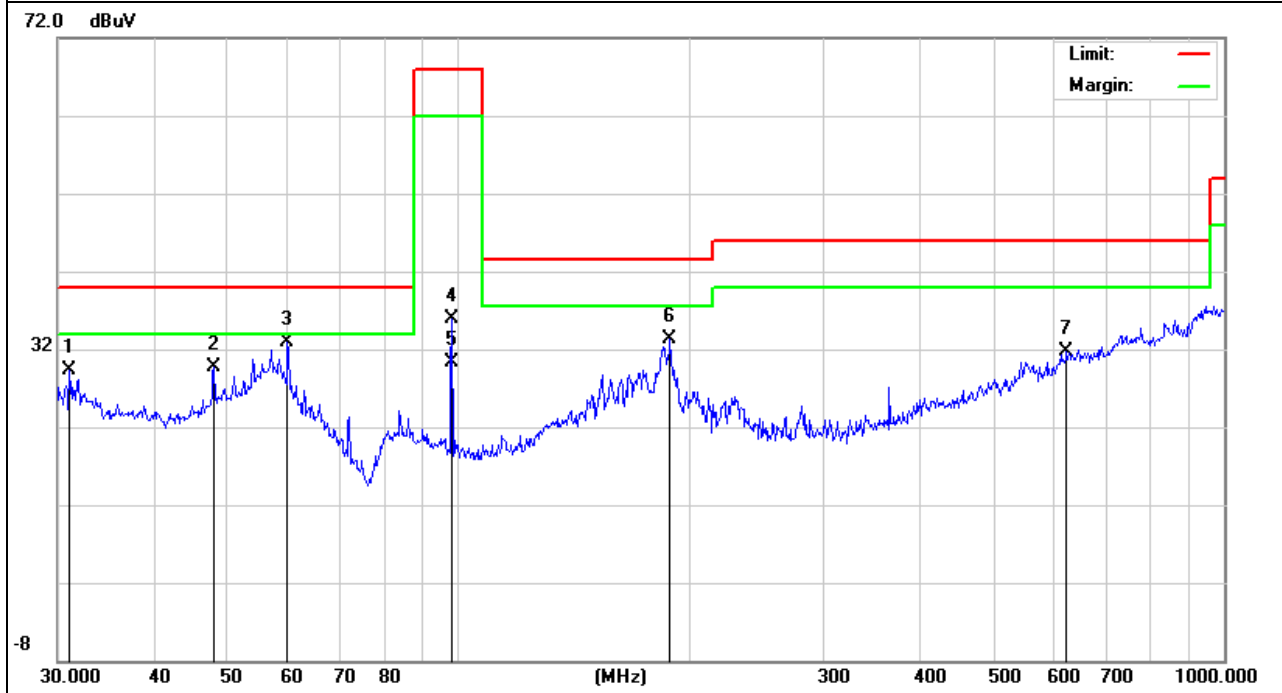

EUT :	WIRELESS HANDS-FREE CAR KIT	Model Name :	BTFM5
Temperature :	20 °C	Relative Humidity :	48%
Pressure :	1010 hPa	Test Voltage :	DC 12.0V
Test Mode :	98.1MHz	Polarization :	Horizontal

Frequency (MHz)	Meter Reading (dBμV)	Factor (dB)	Emission Level (dBμV/m)	Limits (dBμV/m)	Margin (dB)	Remark
59.8588	23.47	6.50	29.97	40.00	-10.03	QP
83.8156	19.28	9.30	28.58	40.00	-11.42	QP
98.1419	33.12	11.32	44.44	68.00	-23.56	peak
98.1419	28.89	11.32	40.21	48.00	-7.79	AVG
194.4533	25.93	9.87	35.80	43.50	-7.70	QP
287.9904	20.49	15.58	36.07	46.00	-9.93	QP
480.5276	9.27	21.41	30.68	46.00	-15.32	QP

Remark:

1. Factor = Antenna Factor + Cable Loss – Pre-amplifier.

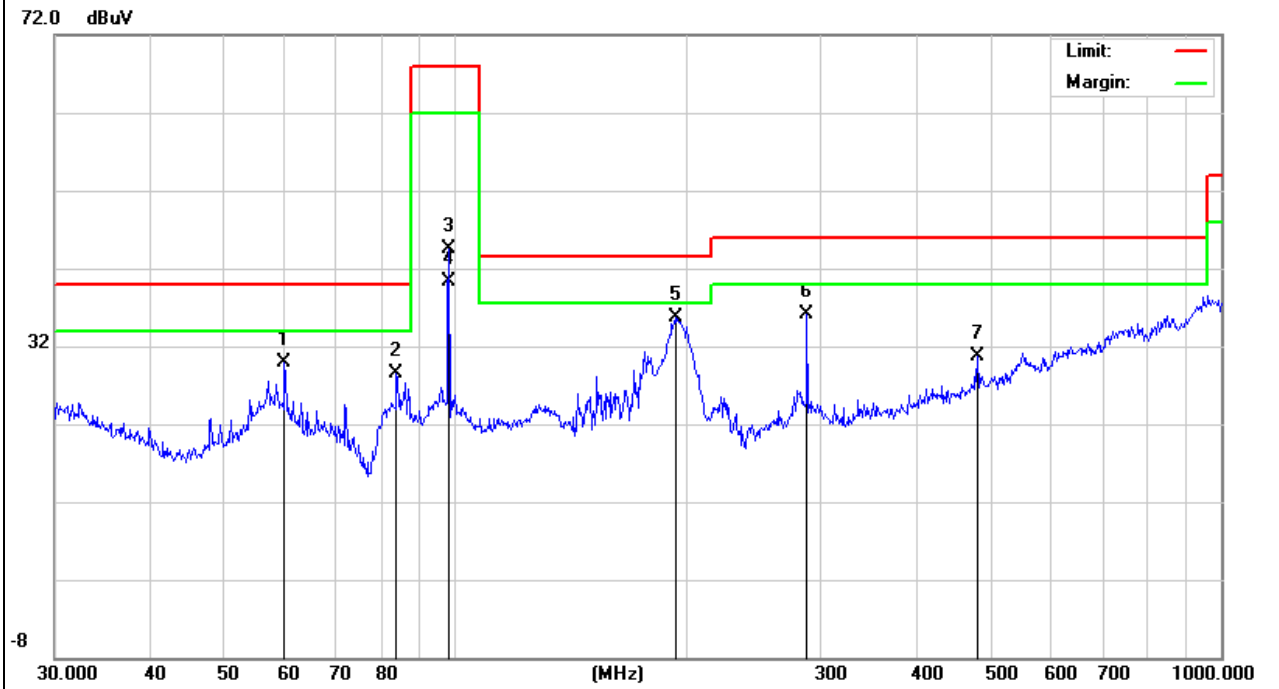

EUT :	WIRELESS HANDS-FREE CAR KIT	Model Name :	BTFM5
Temperature :	20 °C	Relative Humidity :	48%
Pressure :	1010 hPa	Test Voltage :	DC 12.0V
Test Mode :	107.9MHz	Polarization :	Vertical

Frequency (MHz)	Meter Reading (dBμV)	Factor (dB)	Emission Level (dBμV/m)	Limits (dBμV/m)	Margin (dB)	Remark
47.9939	17.70	11.33	29.03	40.00	-10.97	QP
59.8588	25.27	6.50	31.77	40.00	-8.23	QP
107.8877	19.31	12.23	31.54	68.00	-36.46	peak
107.8877	14.12	12.23	26.35	48.00	-21.65	AVG
162.0414	17.91	11.51	29.42	43.50	-14.08	QP
188.4125	21.68	10.38	32.06	43.50	-11.44	QP
833.3170	8.20	28.42	36.62	46.00	-9.38	QP

Remark:

1. Factor = Antenna Factor + Cable Loss – Pre-amplifier.

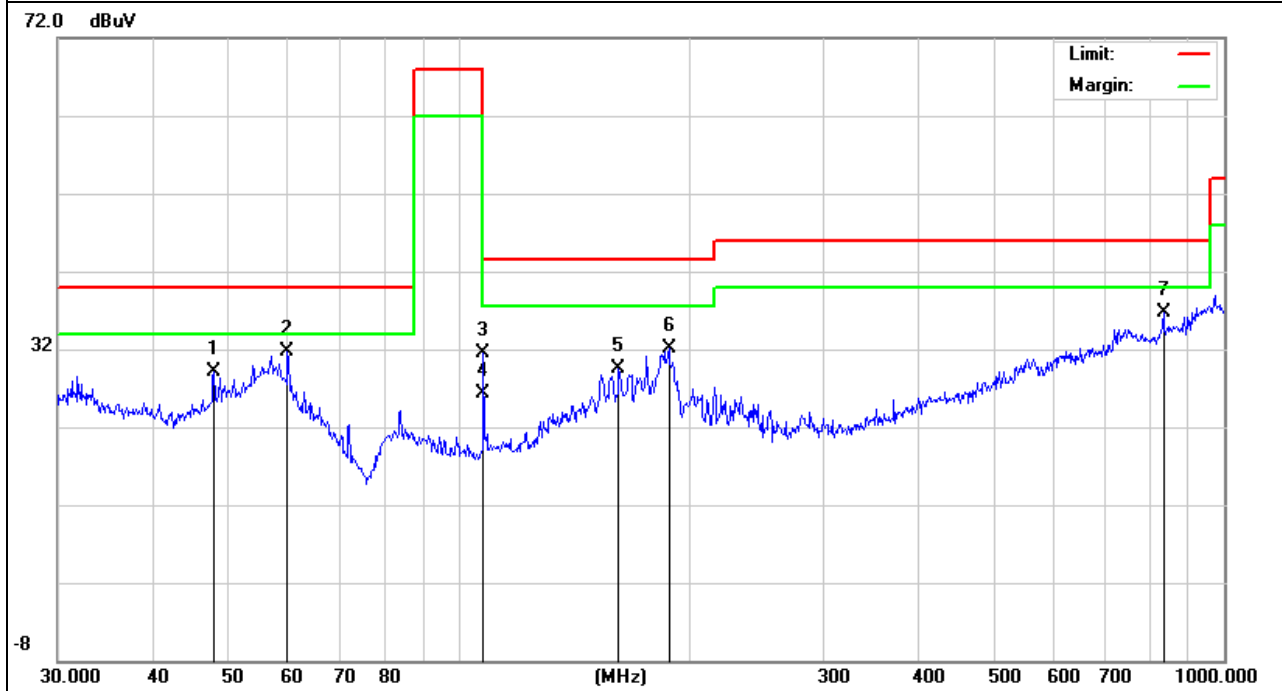

EUT :	WIRELESS HANDS-FREE CAR KIT	Model Name :	BTFM5
Temperature :	20 °C	Relative Humidity :	48%
Pressure :	1010 hPa	Test Voltage :	DC 12.0V
Test Mode :	107.9MHz	Polarization :	Horizontal

Frequency (MHz)	Meter Reading (dBμV)	Factor (dB)	Emission Level (dBμV/m)	Limits (dBμV/m)	Margin (dB)	Remark
59.8588	21.41	6.50	27.91	40.00	-12.09	QP
84.1099	17.28	9.38	26.66	40.00	-13.34	QP
107.8877	23.43	12.23	35.66	68.00	-32.34	peak
107.8876	18.79	12.23	31.02	48.00	-16.98	AVG
178.1326	20.38	10.83	31.21	43.50	-12.29	QP
192.4186	24.55	10.02	34.57	43.50	-8.93	QP
839.1817	6.89	28.61	35.50	46.00	-10.50	QP

Remark:

1. Factor = Antenna Factor + Cable Loss – Pre-amplifier.

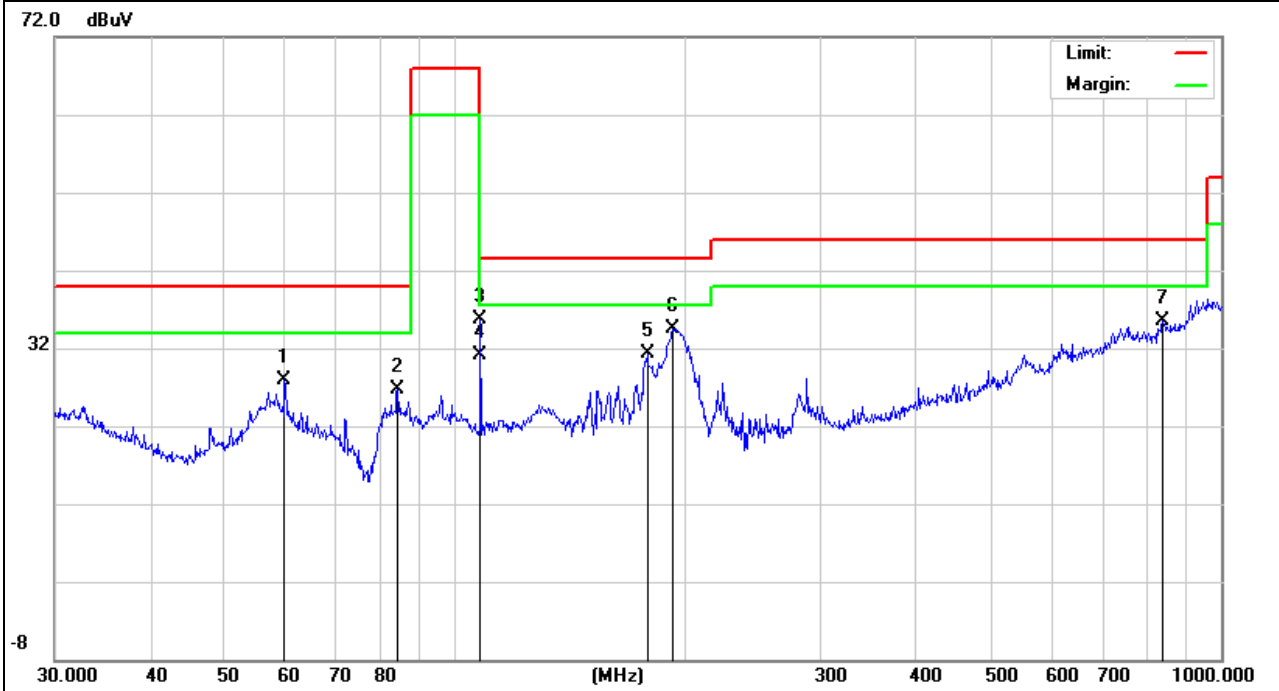

3.4.7 TEST RESULTS (BAND EDGE EMISSION)

EUT :	WIRELESS HANDS-FREE CAR KIT	Model Name :	BTFM5
Temperature :	20 °C	Relative Humidity :	48%
Pressure :	1010 hPa	Test Voltage :	DC 12.0V
Test Mode :	88.1MHz	Polarization :	Vertical

Frequency (MHz)	Meter Reading (dBμV)	Factor (dB)	Emission Level (dBμV/m)	Limits (dBμV/m)	Margin (dB)	Remark
88.0000	26.00	9.95	35.95	40.00	-4.05	QP

Remark:
Factor = Antenna Factor + Cable Loss – Pre-amplifier.

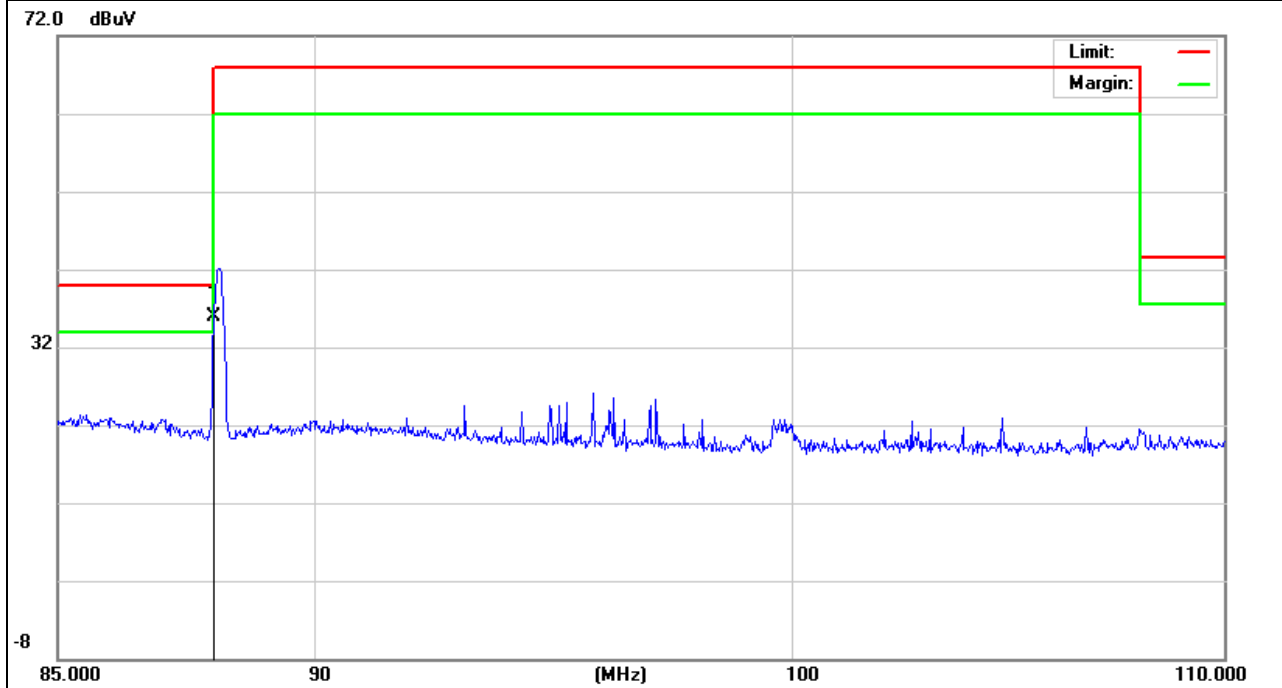

EUT :	WIRELESS HANDS-FREE CAR KIT	Model Name :	BTFM5
Temperature :	20 °C	Relative Humidity :	48%
Pressure :	1010 hPa	Test Voltage :	DC 12.0V
Test Mode :	88.1MHz	Polarization :	Horizontal

Frequency (MHz)	Meter Reading (dBμV)	Factor (dB)	Emission Level (dBμV/m)	Limits (dBμV/m)	Margin (dB)	Remark
88.0000	28.49	9.95	38.44	40.00	-1.56	QP

Remark:
Factor = Antenna Factor + Cable Loss – Pre-amplifier.

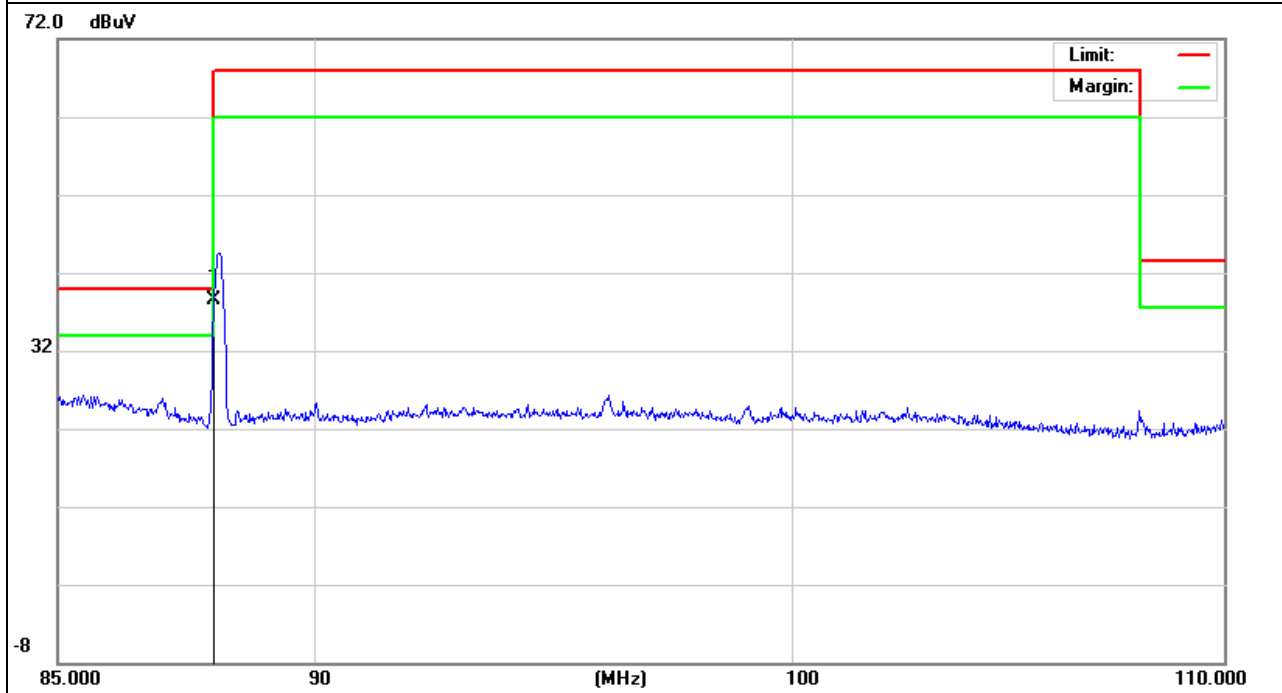

EUT :	WIRELESS HANDS-FREE CAR KIT	Model Name :	BTFM5
Temperature :	20 °C	Relative Humidity :	48%
Pressure :	1010 hPa	Test Voltage :	DC 12.0V
Test Mode :	107.9MHz	Polarization :	Vertical

Frequency (MHz)	Meter Reading (dBμV)	Factor (dB)	Emission Level (dBμV/m)	Limits (dBμV/m)	Margin (dB)	Detector Type
108.0000	14.78	12.23	27.01	43.50	-16.49	QP

Remark:
Factor = Antenna Factor + Cable Loss – Pre-amplifier.

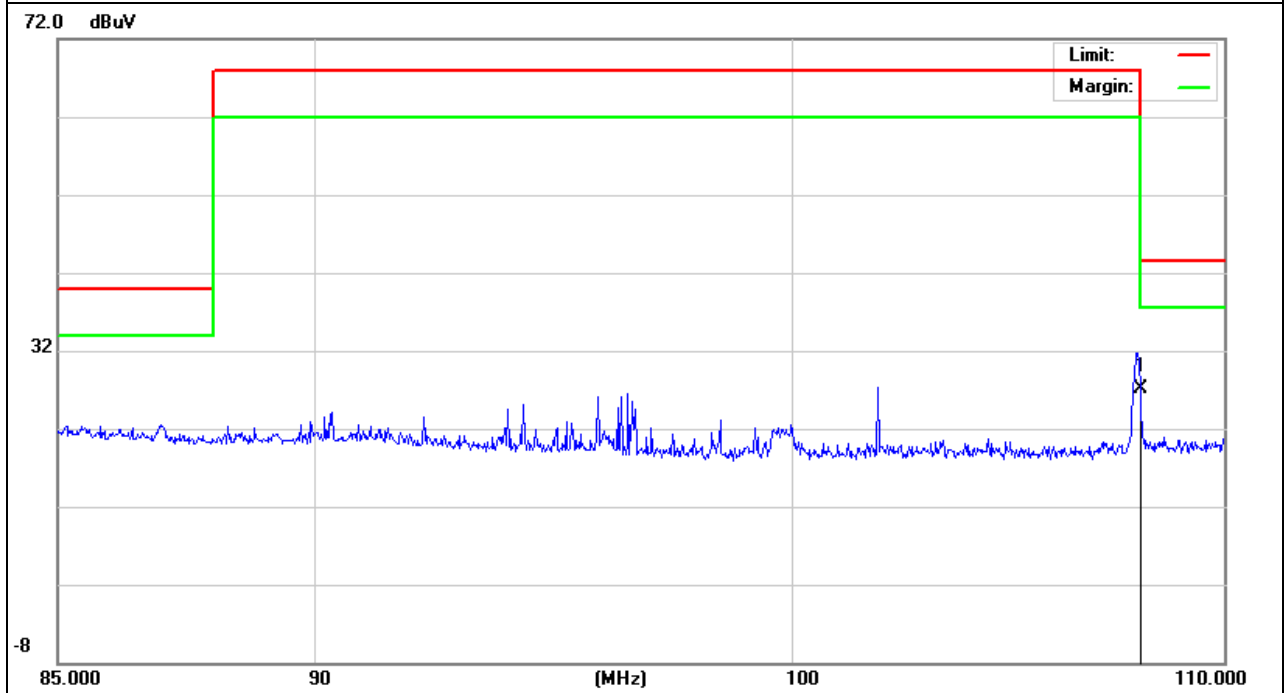

EUT :	WIRELESS HANDS-FREE CAR KIT	Model Name :	BTFM5
Temperature :	20 °C	Relative Humidity :	48%
Pressure :	1010 hPa	Test Voltage :	DC 12.0V
Test Mode :	107.9MHz	Polarization :	Horizontal

Frequency (MHz)	Meter Reading (dBμV)	Factor (dB)	Emission Level (dBμV/m)	Limits (dBμV/m)	Margin (dB)	Detector Type
108.0000	19.07	12.23	31.30	43.50	-12.20	QP

Remark:
Factor = Antenna Factor + Cable Loss – Pre-amplifier.

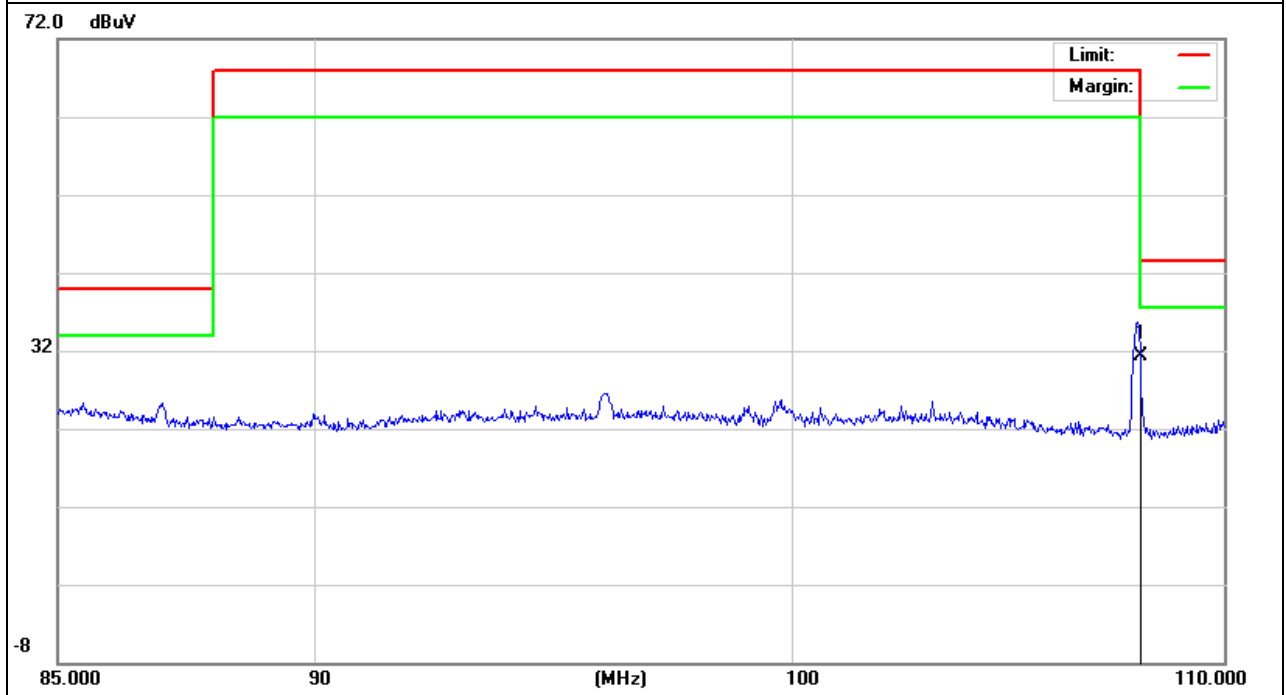

4. BANDWIDTH TEST

4.1 TEST PROCEDURE

- a. The EUT was directly connected to the spectrum analyzer and antenna output port as show in the block diagram below,
- b. Spectrum Setting : RBW= 10KHz, VBW \geq RBW, Sweep time = Auto.

4.2 DEVIATION FROM STANDARD

No deviation.

4.3 TEST SETUP



4.4 TEST RESULTS

EUT :	WIRELESS HANDS-FREE CAR KIT	Model Name :	BTFM5
Temperature :	26 °C	Relative Humidity :	53%
Pressure :	1020 hPa	Test Power :	DC 12.0V
Test Mode :	TX		

Test Channel	Frequency (MHz)	20 dBc Bandwidth (KHz)	Limit (KHz)
Low	88.1	82.388	200
Mid	98.1	88.016	200
High	107.9	88.546	200

The Lowest Channel: 88.1MHz

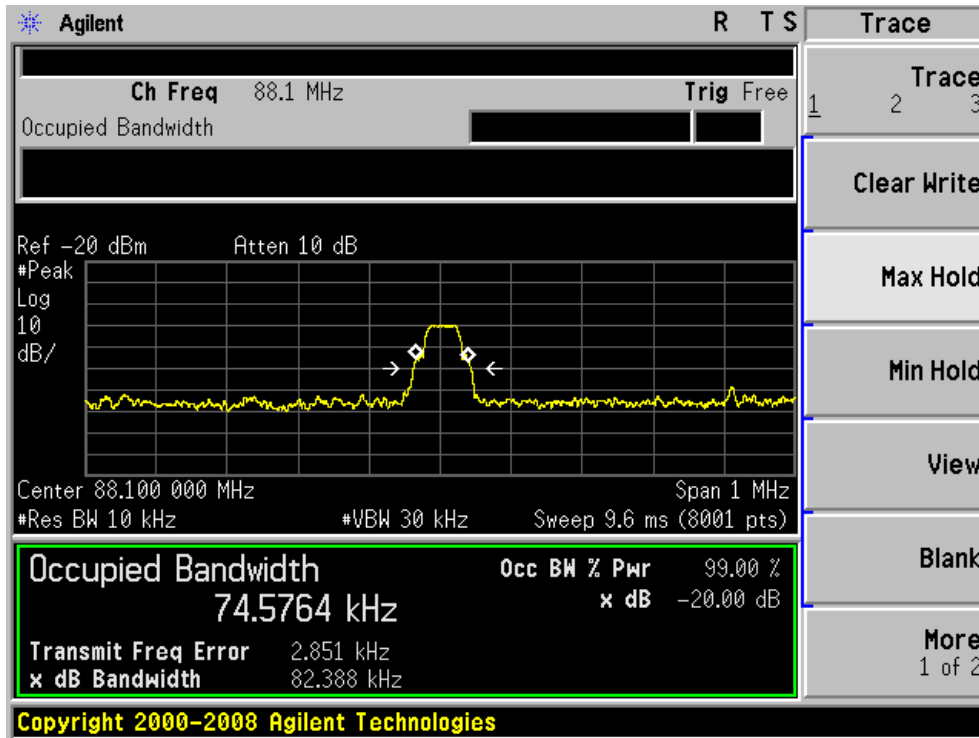

The Middle Channel: 98.1MHz

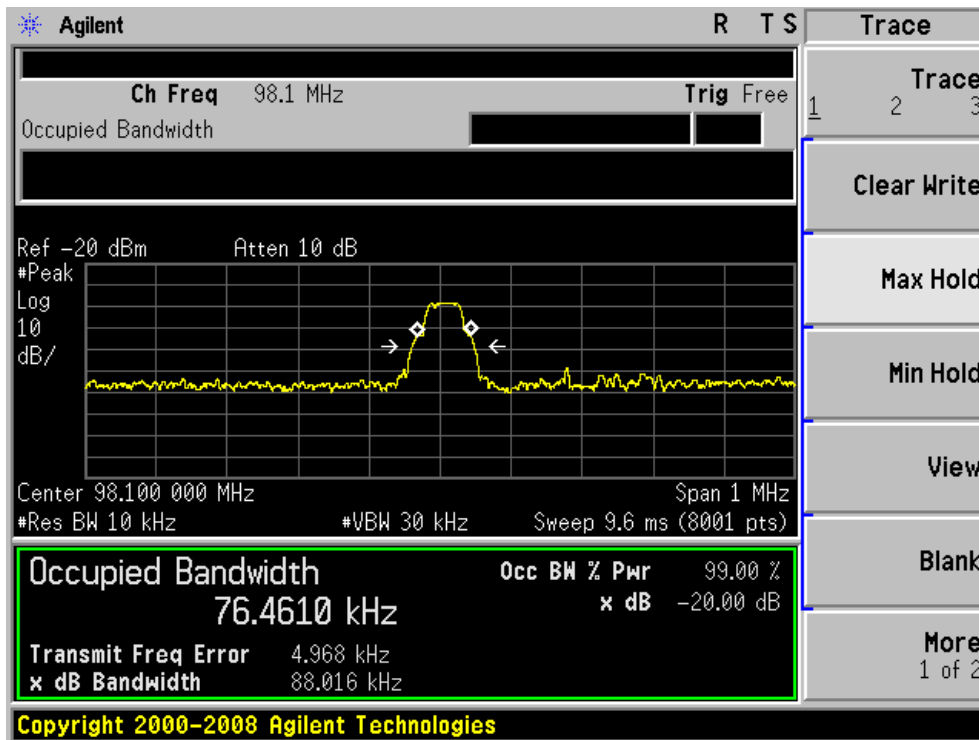

The High Channel:107.9MHz

