



Sensor Off

WWAN Band		Exposure Position	1	2	5	2+5	1+2+5
			WWAN	2.4GHz WLAN Ant 3+6	5GHz WLAN Ant 5+6	Summed	Summed
			10g SAR (W/kg)	10g SAR (W/kg)	10g SAR (W/kg)	10g SAR (W/kg)	10g SAR (W/kg)
WCDMA	WCDMA IV	Front at 5mm	1.832		0.365	0.37	2.20
		Back at 7mm	2.044	0.300	0.365	0.67	2.71
		Top side at 0mm			0.310	0.31	0.31
		Bottom side at 8mm	2.338			0.00	2.34
	WCDMA II	Front at 5mm	2.028		0.365	0.37	2.39
		Back at 7mm	2.178	0.300	0.365	0.67	2.84
		Top side at 0mm			0.310	0.31	0.31
		Bottom side at 8mm	2.436			0.00	2.44
LTE	LTE Band 66	Front at 5mm	2.666		0.365	0.37	3.03
		Back at 7mm	2.308	0.300	0.365	0.67	2.97
		Top side at 0mm			0.310	0.31	0.31
		Bottom side at 8mm	2.995			0.00	3.00
	LTE Band 2	Front at 5mm	2.560		0.365	0.37	2.93
		Back at 7mm	2.655	0.300	0.365	0.67	3.32
		Top side at 0mm			0.310	0.31	0.31
		Bottom side at 8mm	2.995			0.00	3.00
	LTE Band 7	Front at 5mm	1.503		0.365	0.37	1.87
		Back at 7mm	1.396	0.300	0.365	0.67	2.06
		Top side at 0mm			0.310	0.31	0.31
		Bottom side at 8mm	1.184			0.00	1.18
	LTE Band 42	Front at 5mm			0.365	0.37	0.37
		Back at 8mm	2.675	0.300	0.365	0.67	3.34
		Top side at 0mm			0.310	0.31	0.31
		Bottom side at 8mm				0.00	0.00
NR	N66	Front at 5mm	1.292		0.365	0.37	1.66
		Back at 7mm	1.144	0.300	0.365	0.67	1.81
		Top side at 5mm	2.260		0.310	0.31	2.57
		Bottom side at 0mm				0.00	0.00
	N7	Front at 5mm	0.825		0.365	0.37	1.19
		Back at 7mm	0.701	0.300	0.365	0.67	1.37
		Top side at 5mm	1.726		0.310	0.31	2.04
		Bottom side at 0mm				0.00	0.00
	N77	Front at 5mm			0.365	0.37	0.37
		Back at 8mm	0.653	0.300	0.365	0.67	1.32
		Top side at 0mm			0.310	0.31	0.31
		Bottom side at 8mm				0.00	0.00
	N78	Front at 5mm			0.365	0.37	0.37
		Back at 8mm	0.769	0.300	0.365	0.67	1.43
		Top side at 0mm			0.310	0.31	0.31
		Bottom side at 8mm				0.00	0.00

17.6 SPLSR Evaluation and Analysis

General Note:

1. When standalone SAR is measured for both antennas in the pair, the peak location separation distance is computed by the square root of $[(x1-x2)^2 + (y1-y2)^2 + (z1-z2)^2]$, where $(x1, y1, z1)$ and $(x2, y2, z2)$ are the coordinates in the area scans or extrapolated peak SAR locations in the zoom scans, as appropriate.
2. $SPLSR = (SAR1 + SAR2)1.5 / (\text{min. separation distance, mm})$. If $SPLSR \leq 0.04$ for 1g SAR and $SPLSR \leq 0.10$ for 10g SAR, simultaneously transmission SAR measurement is not necessary.

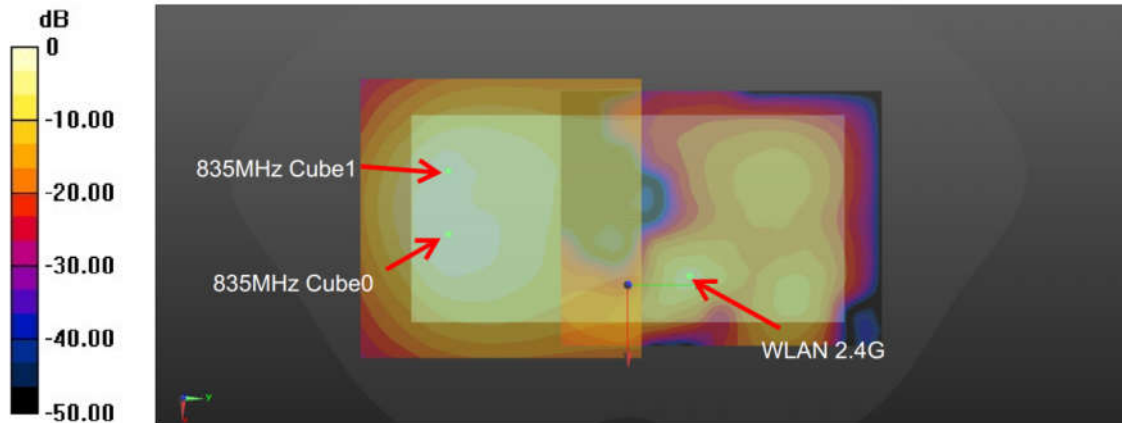

WWAN+WLAN2.4GHz_Back 5mm

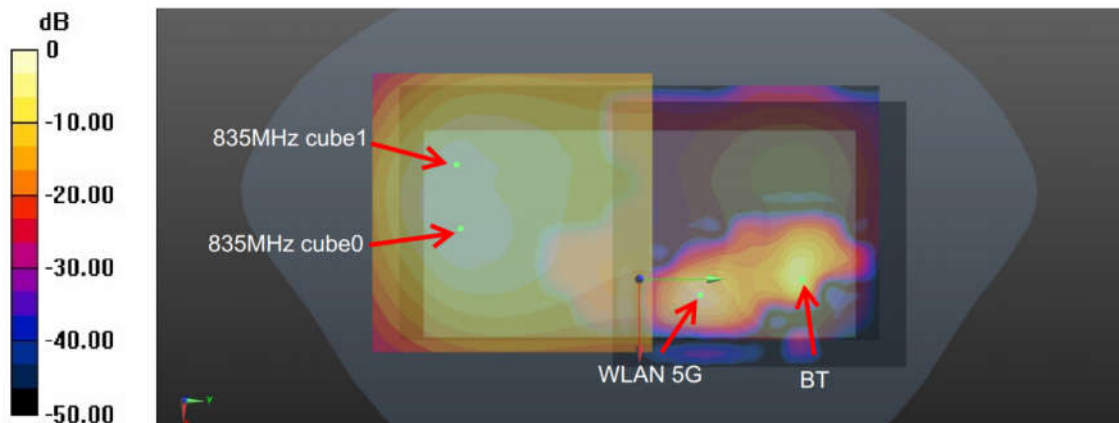

WWAN+WLAN5GHz+Bluetooth_Back 5mm

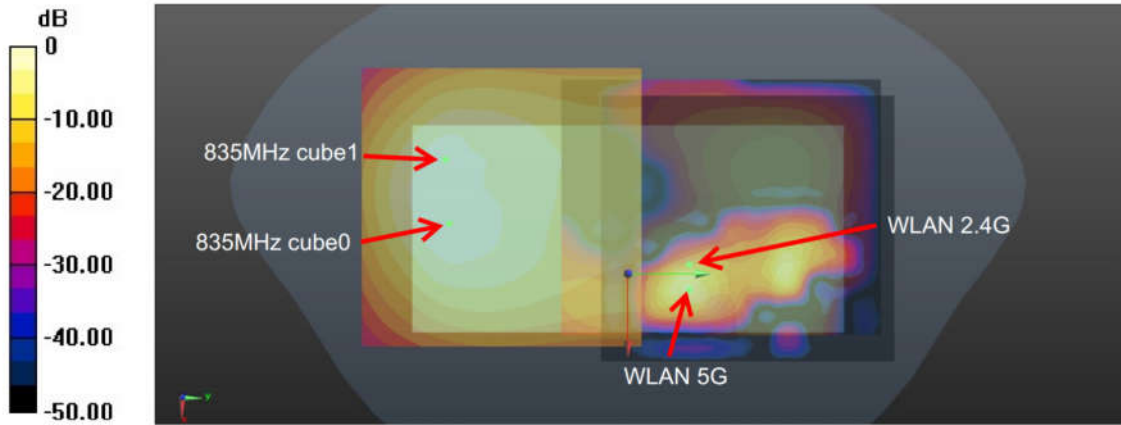

WWAN+WLAN2.4GHz+WLAN5GHz_Back 5mm

Hotspot (WWAN+2.4G&WWAN+5G+BT)												
Case #01	Band	Position	SAR (W/kg)	Gap (mm)	SAR peak location (m)			3D distance (mm)	Summed SAR (W/kg)	SPLSR Results	Simultaneous SAR	
					X	Y	Z					
	GSM850	Back	1.271	5	-0.0155	-0.079	-0.206	98.6	1.65	0.02	Not required	
	WLAN2.4GHz		0.377	5	0.0016	0.018	-0.21					
Case #02	Band	Position	SAR (W/kg)	Gap (mm)	SAR peak location (m)			3D distance (mm)	Summed SAR (W/kg)	SPLSR Results	Simultaneous SAR	
					X	Y	Z					
		GSM850	Back	1.271	5	-0.0155	-0.079	-0.206	101.1	1.64	0.02	Not required
		WLAN5GHz		0.367	5	0.005	0.02	-0.206				
		GSM850	Back	1.271	5	-0.0155	-0.079	-0.206	141.1	1.37	0.01	Not required
		Bluetooth		0.101	5	0.0002	0.0612	-0.21				
	WLAN5GHz	Back	0.367	5	0.005	0.02	-0.206	41.7	0.47	0.01	Not required	
	Bluetooth		0.101	5	0.0002	0.0612	-0.21					
Case #03	Band	Position	SAR (W/kg)	Gap (mm)	SAR peak location (m)			3D distance (mm)	Summed SAR (W/kg)	SPLSR Results	Simultaneous SAR	
					X	Y	Z					
		WCDMA V	Back	1.335	5	-0.019	-0.067	-0.21	87.5	1.71	0.03	Not required
		WLAN2.4GHz		0.377	5	0.0016	0.018	-0.21				
	WCDMA V	Back	1.025	5	-0.027	-0.075	-0.21	97.3	1.40	0.02	Not required	
	WLAN2.4GHz		0.377	5	0.0016	0.018	-0.21					
Case #04	Band	Position	SAR (W/kg)	Gap (mm)	SAR peak location (m)			3D distance (mm)	Summed SAR (W/kg)	SPLSR Results	Simultaneous SAR	
					X	Y	Z					
		WCDMA V	Back	1.335	5	-0.019	-0.067	-0.21	90.3	1.70	0.02	Not required
		WLAN5GHz		0.367	5	0.005	0.02	-0.206				
		WCDMA V	Back	1.335	5	-0.019	-0.067	-0.21	129.6	1.44	0.01	Not required
		Bluetooth		0.101	5	0.0002	0.0612	-0.21				
		WCDMA V	Back	1.025	5	-0.027	-0.075	-0.21	100.3	1.39	0.02	Not required
		WLAN5GHz		0.367	5	0.005	0.02	-0.206				
		WCDMA V	Back	1.025	5	-0.027	-0.075	-0.21	138.9	1.13	0.01	Not required
	Bluetooth	0.101		5	0.0002	0.0612	-0.21					
	WLAN5GHz	Back	0.367	5	0.005	0.02	-0.206	41.7	0.47	0.01	Not required	
	Bluetooth		0.101	5	0.0002	0.0612	-0.21					
Case #05	Band	Position	SAR (W/kg)	Gap (mm)	SAR peak location (m)			3D distance (mm)	Summed SAR (W/kg)	SPLSR Results	Simultaneous SAR	
					X	Y	Z					
		LTE Band 26	Back	1.285	5	-0.019	-0.067	-0.21	87.5	1.66	0.02	Not required
		WLAN2.4GHz		0.377	5	0.0016	0.018	-0.21				
	LTE Band 26	Back	1.013	5	-0.027	-0.0765	-0.21	98.7	1.39	0.02	Not required	
	WLAN2.4GHz		0.377	5	0.0016	0.018	-0.21					



Case #06	Band	Position	SAR (W/kg)	Gap	SAR peak location (m)			3D distance (mm)	Summed SAR (W/kg)	SPLSR Results	Simultaneous SAR
				(mm)	X	Y	Z				
LTE Band 26	WLAN5GHz	Back	1.285	5	-0.019	-0.067	-0.21	90.3	1.65	0.02	Not required
			0.367	5	0.005	0.02	-0.206				
LTE Band 26	Bluetooth	Back	1.285	5	-0.019	-0.067	-0.21	129.6	1.39	0.01	Not required
			0.101	5	0.0002	0.0612	-0.21				
LTE Band 26	WLAN5GHz	Back	1.013	5	-0.027	-0.0765	-0.21	101.7	1.38	0.02	Not required
			0.367	5	0.005	0.02	-0.206				
LTE Band 26	Bluetooth	Back	1.013	5	-0.027	-0.0765	-0.21	140.4	1.11	0.01	Not required
			0.101	5	0.0002	0.0612	-0.21				
WLAN5GHz	Bluetooth	Back	0.367	5	0.005	0.02	-0.206	41.7	0.47	0.01	Not required
			0.101	5	0.0002	0.0612	-0.21				

Hotspot (WWAN+2.4G+5G)											
Case #07	Band	Position	SAR (W/kg)	Gap	SAR peak location (m)			3D distance (mm)	Summed SAR (W/kg)	SPLSR Results	Simultaneous SAR
				(mm)	X	Y	Z				
GSM850	WLAN2.4GHz	Back	1.271	5	-0.0155	-0.079	-0.206	109.4	1.36	0.01	Not required
			0.089	5	0.0016	0.029	-0.21				
GSM850	WLAN5GHz	Back	1.271	5	-0.0155	-0.079	-0.206	136.7	1.55	0.01	Not required
			0.277	5	-0.002	0.057	-0.206				
WLAN2.4GHz	WLAN5GHz	Back	0.089	5	0.0016	0.029	-0.21	28.5	0.37	0.01	Not required
			0.277	5	-0.002	0.057	-0.206				

Case #08	Band	Position	SAR (W/kg)	Gap	SAR peak location (m)			3D distance (mm)	Summed SAR (W/kg)	SPLSR Results	Simultaneous SAR
				(mm)	X	Y	Z				
WCDMA V	WLAN2.4GHz	Back	1.335	5	-0.019	-0.067	-0.21	98.2	1.42	0.02	Not required
			0.089	5	0.0016	0.029	-0.21				
WCDMA V	WLAN5GHz	Back	1.335	5	-0.019	-0.067	-0.21	125.2	1.61	0.02	Not required
			0.277	5	-0.002	0.057	-0.206				
WCDMA V	WLAN2.4GHz	Back	1.025	5	-0.027	-0.075	-0.21	107.9	1.11	0.01	Not required
			0.089	5	0.0016	0.029	-0.21				
WCDMA V	WLAN5GHz	Back	1.025	5	-0.027	-0.075	-0.21	134.4	1.30	0.01	Not required
			0.277	5	-0.002	0.057	-0.206				
WLAN2.4GHz	WLAN5GHz	Back	0.089	5	0.0016	0.029	-0.21	28.5	0.37	0.01	Not required
			0.277	5	-0.002	0.057	-0.206				

Case #09	Band	Position	SAR (W/kg)	Gap	SAR peak location (m)			3D distance (mm)	Summed SAR (W/kg)	SPLSR Results	Simultaneous SAR
				(mm)	X	Y	Z				
LTE Band 26	WLAN2.4GHz	Back	1.285	5	-0.019	-0.067	-0.21	98.2	1.37	0.02	Not required
			0.089	5	0.0016	0.029	-0.21				
LTE Band 26	WLAN5GHz	Back	1.285	5	-0.019	-0.067	-0.21	125.2	1.56	0.02	Not required
			0.277	5	-0.002	0.057	-0.206				
LTE Band 26	WLAN2.4GHz	Back	1.013	5	-0.027	-0.0765	-0.21	109.3	1.10	0.01	Not required
			0.089	5	0.0016	0.029	-0.21				
LTE Band 26	WLAN5GHz	Back	1.013	5	-0.027	-0.0765	-0.21	135.9	1.29	0.01	Not required
			0.277	5	-0.002	0.057	-0.206				
WLAN2.4GHz	WLAN5GHz	Back	0.089	5	0.0016	0.029	-0.21	28.5	0.37	0.01	Not required
			0.277	5	-0.002	0.057	-0.206				



Body worn (WWAN+2.4G&WWAN+5G+BT)											
	Band	Position	SAR (W/kg)	Gap	SAR peak location (m)			3D distance (mm)	Summed SAR (W/kg)	SPLSR Results	Simultaneous SAR
				(mm)	X	Y	Z				
Case #22	GSM850	Back	1.271	5	-0.0155	-0.079	-0.206	107.4	1.63	0.02	Not required
	WLAN5GHz		0.36	5	0.007	0.026	-0.206				
	GSM850	Back	1.271	5	-0.0155	-0.079	-0.206	141.1	1.37	0.01	Not required
	Bluetooth		0.101	5	0.0002	0.0612	-0.21				
	WLAN5GHz	Back	0.36	5	0.007	0.026	-0.206	36.1	0.46	0.01	Not required
	Bluetooth		0.101	5	0.0002	0.0612	-0.21				
Case #23	WCDMA V	Back	1.335	5	-0.019	-0.067	-0.21	96.6	1.70	0.02	Not required
	WLAN5GHz		0.36	5	0.007	0.026	-0.206				
	WCDMA V	Back	1.335	5	-0.019	-0.067	-0.21	129.6	1.44	0.01	Not required
	Bluetooth		0.101	5	0.0002	0.0612	-0.21				
	WCDMA V	Back	1.025	5	-0.027	-0.075	-0.21	106.6	1.39	0.02	Not required
	WLAN5GHz		0.36	5	0.007	0.026	-0.206				
	WCDMA V	Back	1.025	5	-0.027	-0.075	-0.21	138.9	1.13	0.01	Not required
	Bluetooth		0.101	5	0.0002	0.0612	-0.21				
	WLAN5GHz	Back	0.36	5	0.007	0.026	-0.206	36.1	0.46	0.01	Not required
	Bluetooth		0.101	5	0.0002	0.0612	-0.21				
Case #24	LTE Band 26	Back	1.285	5	-0.019	-0.067	-0.21	96.6	1.65	0.02	Not required
	WLAN5GHz		0.36	5	0.007	0.026	-0.206				
	LTE Band 26	Back	1.285	5	-0.019	-0.067	-0.21	129.6	1.39	0.01	Not required
	Bluetooth		0.101	5	0.0002	0.0612	-0.21				
	LTE Band 26	Back	1.013	5	-0.027	-0.0765	-0.21	108.1	1.37	0.01	Not required
	WLAN5GHz		0.36	5	0.007	0.026	-0.206				
	LTE Band 26	Back	1.013	5	-0.027	-0.0765	-0.21	140.4	1.11	0.01	Not required
	Bluetooth		0.101	5	0.0002	0.0612	-0.21				
	WLAN5GHz	Back	0.36	5	0.007	0.026	-0.206	36.1	0.46	0.01	Not required
Bluetooth	0.101		5	0.0002	0.0612	-0.21					



Body worn (WWAN+2.4G+5G)											
	Band	Position	SAR (W/kg)	Gap (mm)	SAR peak location (m)			3D distance (mm)	Summed SAR (W/kg)	SPLSR Results	Simultaneous SAR
					X	Y	Z				
Case #18	GSM850	Back	1.271	5	-0.0155	-0.079	-0.206	109.4	1.36	0.01	Not required
	WLAN2.4GHz		0.089	5	0.0016	0.029	-0.21				
	GSM850	Back	1.271	5	-0.0155	-0.079	-0.206	106.4	1.56	0.02	Not required
	WLAN5GHz		0.293	5	0.007	0.025	-0.206				
	WLAN2.4GHz	Back	0.089	5	0.0016	0.029	-0.21	7.8	0.38	0.03	Not required
	WLAN5GHz		0.293	5	0.007	0.025	-0.206				
Case #19	WCDMA V	Back	1.335	5	-0.019	-0.067	-0.21	98.2	1.42	0.02	Not required
	WLAN2.4GHz		0.089	5	0.0016	0.029	-0.21				
	WCDMA V	Back	1.335	5	-0.019	-0.067	-0.21	95.7	1.63	0.02	Not required
	WLAN5GHz		0.293	5	0.007	0.025	-0.206				
	WCDMA V	Back	1.025	5	-0.027	-0.075	-0.21	107.9	1.11	0.01	Not required
	WLAN2.4GHz		0.089	5	0.0016	0.029	-0.21				
	WCDMA V	Back	1.025	5	-0.027	-0.075	-0.21	105.7	1.32	0.01	Not required
	WLAN5GHz		0.293	5	0.007	0.025	-0.206				
	WLAN2.4GHz	Back	0.089	5	0.0016	0.029	-0.21	7.8	0.38	0.03	Not required
	WLAN5GHz		0.293	5	0.007	0.025	-0.206				
Case #20	LTE Band 26	Back	1.285	5	-0.019	-0.067	-0.21	98.2	1.37	0.02	Not required
	WLAN2.4GHz		0.089	5	0.0016	0.029	-0.21				
	LTE Band 26	Back	1.285	5	-0.019	-0.067	-0.21	95.7	1.58	0.02	Not required
	WLAN5GHz		0.293	5	0.007	0.025	-0.206				
	LTE Band 26	Back	1.013	5	-0.027	-0.0765	-0.21	109.3	1.10	0.01	Not required
	WLAN2.4GHz		0.089	5	0.0016	0.029	-0.21				
	LTE Band 26	Back	1.013	5	-0.027	-0.0765	-0.21	107.1	1.31	0.01	Not required
	WLAN5GHz		0.293	5	0.007	0.025	-0.206				
	WLAN2.4GHz	Back	0.089	5	0.0016	0.029	-0.21	7.8	0.38	0.03	Not required
WLAN5GHz	0.293		5	0.007	0.025	-0.206					

18. Supplemental tuner tests results

General Note:

1. This device implements impedance tuner (144 status) antenna tuning techniques in the GSM850/1900, WCDMA IV/III/V, LTE B12/13/26/66/27/41.
2. SAR test proposal was measured according to the normally required SAR configurations with the tuner active and worst tune state (auto tune) was used for SAR testing and this design will provide the highest power at different user scenarios and would not influence to the antenna characteristics other than impedance matching.
3. The following test procedure was followed to demonstrate that the SAR results in this report represent the appropriate SAR test conditions. For bands with dynamic tuning implemented, SAR will be measured according to the required FCC SAR test procedures with the dynamic tuner active to allow the device to automatically tune to the antenna state for the respective RF exposure test configurations. Additional single point SAR time-sweep measurements will be evaluated for other tuner states to determine that the other tuner configurations would result in equivalent or lower SAR values.
4. To evaluate all of the tuner states, the 144 tuner states are divided evenly among band, mode and exposure combinations so that at least one single point SAR measurement is measured in each configuration. Single point time-sweep measurements will be performed at the peak SAR location determined by the zoom scan of the configuration with the highest reported SAR for each combination. The tuner state will be established remotely so that the device is not moved for the entire series of single point SAR for the tuner states in each combination. The SAR probe will remain stationary at the same position throughout the entire series of single point measurements for each combination.
5. According to TCBC 201904 workshop, total number tuner states divided evenly among each supported band / air interface and exposure condition combination.
6. This device supports LTE B4 / B5 / B17 / B38 and B66 / B26 / B12 / B41. Since the supported frequency span for LTE B4 / B5 / B17 / B38 falls completely within the supports frequency span for LTE B66 / B26 / B12 / B41, both LTE bands have the same target power, and both LTE bands share the same transmission path; therefore, chose LTE B66 / B26 / B12 / B41 for dynamic antenna analysis.
7. The tuner state was established remotely through Wi-Fi so that the device is not moved for the entire series of single point SAR for the tuner states in each combination (band, mode, exposure conditions).

18.1 Supplemental Tuner Head & Body SAR Results

Please refer to Appendix F.

Test Engineer : Hank Huang, Bin He, David Dai



19. Uncertainty Assessment

Per KDB 865664 D01 SAR measurement 100MHz to 6GHz, when the highest measured 1-g SAR within a frequency band is < 1.5 W/kg and the measured 10-g SAR within a frequency band is < 3.75 W/kg. The expanded SAR measurement uncertainty must be $\leq 30\%$, for a confidence interval of $k = 2$. If these conditions are met, extensive SAR measurement uncertainty analysis described in IEEE Std 1528-2013 is not required in SAR reports submitted for equipment approval. For this device, the highest measured 1-g SAR is less 1.5W/kg and highest measured 10-g SAR is less 3.75W/kg. Therefore, the measurement uncertainty table is not required in this report.

20. References

- [1] FCC 47 CFR Part 2 “Frequency Allocations and Radio Treaty Matters; General Rules and Regulations”
- [2] ANSI/IEEE Std. C95.1-1992, “IEEE Standard for Safety Levels with Respect to Human Exposure to Radio Frequency Electromagnetic Fields, 3 kHz to 300 GHz”, September 1992
- [3] IEEE Std. 1528-2013, “IEEE Recommended Practice for Determining the Peak Spatial-Average Specific Absorption Rate (SAR) in the Human Head from Wireless Communications Devices: Measurement Techniques”, Sep 2013
- [4] SPEAG DASY System Handbook
- [5] FCC KDB 865664 D01 v01r04, "SAR Measurement Requirements for 100 MHz to 6 GHz", Aug 2015.
- [6] FCC KDB 865664 D02 v01r02, “RF Exposure Compliance Reporting and Documentation Considerations” Oct 2015.
- [7] FCC KDB 447498 D01 v06, “Mobile and Portable Device RF Exposure Procedures and Equipment Authorization Policies”, Oct 2015
- [8] FCC KDB 648474 D04 v01r03, “SAR Evaluation Considerations for Wireless Handsets”, Oct 2015.
- [9] FCC KDB 248227 D01 v02r02, “SAR Guidance for IEEE 802.11 (WiFi) Transmitters”, Oct 2015.
- [10] FCC KDB 616217 D04 v01r02, “SAR Evaluation Considerations for Laptop, Notebook, Netbook and Tablet Computers”, Oct 2015
- [11] FCC KDB 941225 D01 v03r01, “3G SAR MEAUREMENT PROCEDURES”, Oct 2015
- [12] FCC KDB 941225 D05 v02r05, “SAR Evaluation Considerations for LTE Devices”, Dec 2015
- [13] FCC KDB 941225 D05A v01r02, “Rel. 10 LTE SAR Test Guidance and KDB Inquiries”, Oct 2015
- [14] FCC KDB 941225 D06 v02r01, "SAR Evaluation Procedures for Portable Devices with Wireless Router Capabilities", Oct 2015.

-----THE END-----



Appendix A. Plots of System Performance Check

The plots are shown as follows.

System Check_Head_750MHz

DUT: D750V3-SN:1099

Communication System: UID 0, CW (0); Frequency: 750 MHz; Duty Cycle: 1:1

Medium: HSL_750_210523 Medium parameters used: $f = 750 \text{ MHz}$; $\sigma = 0.895 \text{ S/m}$; $\epsilon_r = 41.004$; $\rho = 1000 \text{ kg/m}^3$

Ambient Temperature : 23.6 °C; Liquid Temperature : 22.5 °C

DASY5 Configuration:

- Probe: EX3DV4 - SN7641; ConvF(11.05, 11.05, 11.05); Calibrated: 2021/3/15
- Sensor-Surface: 1.4mm (Mechanical Surface Detection)
- Electronics: DAE4 Sn1664; Calibrated: 2021/3/1
- Phantom: Twin-SAM V8.0 (Right); Type: QD 000 P41 AA; Serial: 2033
- Measurement SW: DASY52, Version 52.10 (4); SEMCAD X Version 14.6.14 (7483)

Pin=250mW/Area Scan (61x61x1): Interpolated grid: $dx=1.500 \text{ mm}$, $dy=1.500 \text{ mm}$
Maximum value of SAR (interpolated) = 2.96 W/kg

Pin=250mW/Zoom Scan (5x5x7)/Cube 0: Measurement grid: $dx=8\text{mm}$, $dy=8\text{mm}$, $dz=5\text{mm}$
Reference Value = 61.22 V/m; Power Drift = -0.04 dB
Peak SAR (extrapolated) = 3.31 W/kg
SAR(1 g) = 2.24 W/kg; SAR(10 g) = 1.5 W/kg
Maximum value of SAR (measured) = 2.93 W/kg

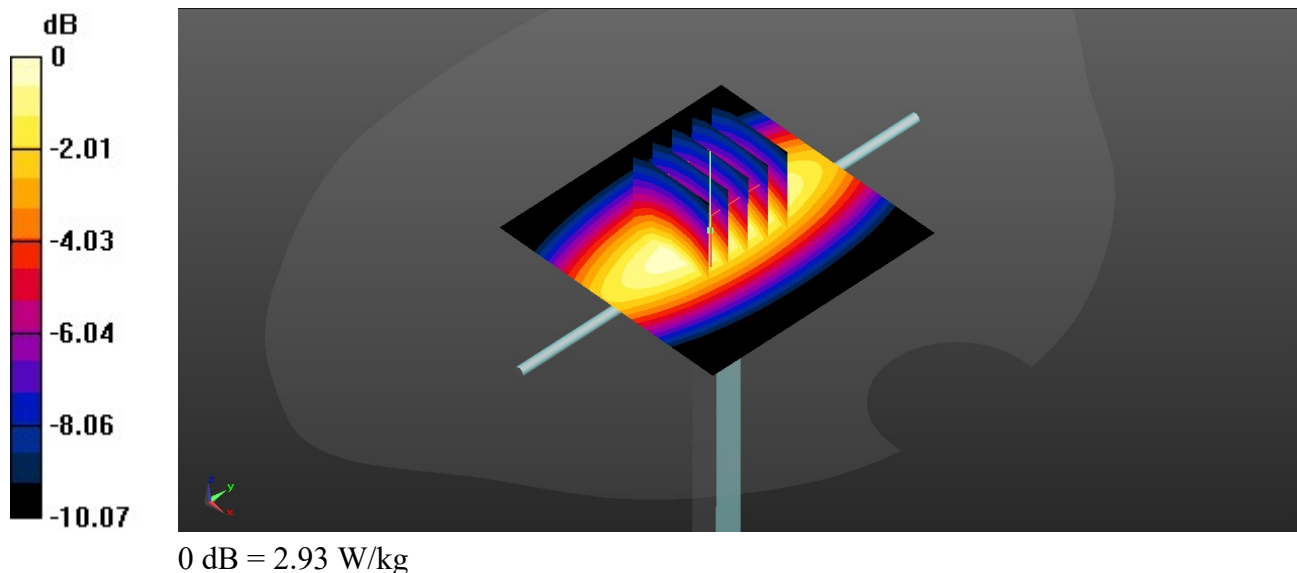

System Check_Head_750MHz

DUT: D750V3-SN:1099

Communication System: UID 0, CW (0); Frequency: 750 MHz; Duty Cycle: 1:1

Medium: HSL_750_210530 Medium parameters used: $f = 750$ MHz; $\sigma = 0.921$ S/m; $\epsilon_r = 41.563$; $\rho = 1000$ kg/m³

Ambient Temperature : 23.3 °C; Liquid Temperature : 22.4 °C

DASY5 Configuration:

- Probe: EX3DV4 - SN7641; ConvF(11.05, 11.05, 11.05); Calibrated: 2021/3/15
- Sensor-Surface: 1.4mm (Mechanical Surface Detection)
- Electronics: DAE4 Sn1664; Calibrated: 2021/3/1
- Phantom: Twin-SAM V8.0 (Right); Type: QD 000 P41 AA; Serial: 2033
- Measurement SW: DASY52, Version 52.10 (4); SEMCAD X Version 14.6.14 (7483)

Pin=250mW/Area Scan (61x61x1): Interpolated grid: dx=1.500 mm, dy=1.500 mm
Maximum value of SAR (interpolated) = 3.05 W/kg

Pin=250mW/Zoom Scan (5x5x7)/Cube 0: Measurement grid: dx=8mm, dy=8mm, dz=5mm
Reference Value = 61.22 V/m; Power Drift = -0.03 dB
Peak SAR (extrapolated) = 3.40 W/kg
SAR(1 g) = 2.3 W/kg; SAR(10 g) = 1.54 W/kg
Maximum value of SAR (measured) = 3.02 W/kg

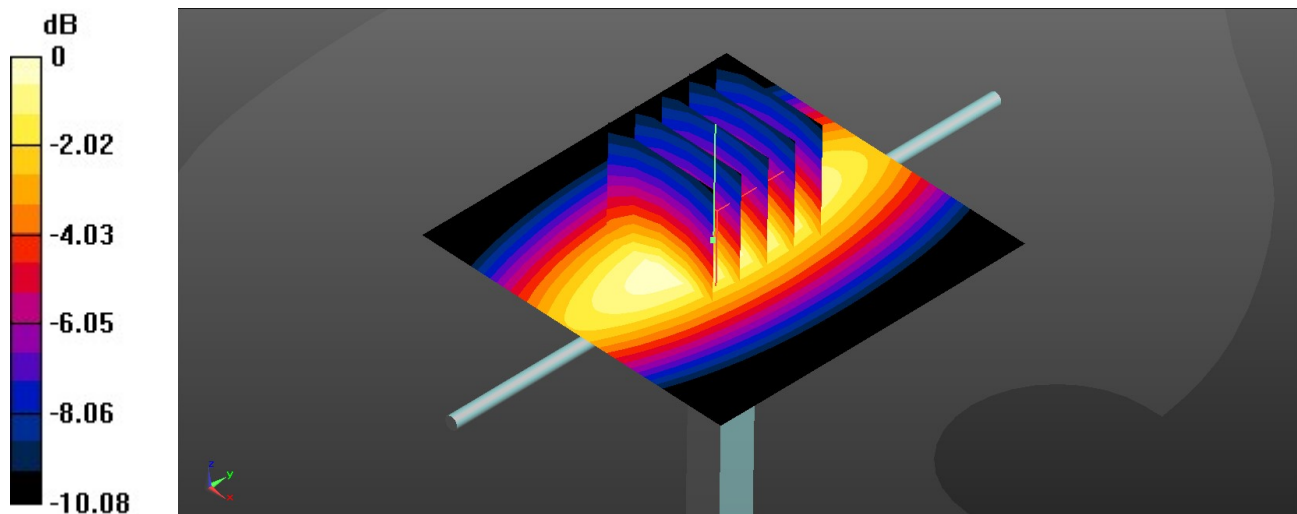

0 dB = 3.02 W/kg

System Check_Head_835MHz

DUT: D835V2-SN:4d162

Communication System: UID 0, CW (0); Frequency: 835 MHz; Duty Cycle: 1:1

Medium: HSL_835_210525 Medium parameters used: $f = 835$ MHz; $\sigma = 0.916$ S/m; $\epsilon_r = 41.029$; $\rho = 1000$ kg/m³

Ambient Temperature : 23.5 °C; Liquid Temperature : 22.5 °C

DASY5 Configuration:

- Probe: EX3DV4 - SN7641; ConvF(10.9, 10.9, 10.9); Calibrated: 2021/3/15
- Sensor-Surface: 1.4mm (Mechanical Surface Detection)
- Electronics: DAE4 Sn1664; Calibrated: 2021/3/1
- Phantom: Twin-SAM V8.0 (Right); Type: QD 000 P41 AA; Serial: 2033
- Measurement SW: DASY52, Version 52.10 (4); SEMCAD X Version 14.6.14 (7483)

Pin=250mW/Area Scan (61x61x1): Interpolated grid: dx=1.500 mm, dy=1.500 mm
Maximum value of SAR (interpolated) = 3.26 W/kg

Pin=250mW/Zoom Scan (5x5x7)/Cube 0: Measurement grid: dx=8mm, dy=8mm, dz=5mm
Reference Value = 62.99 V/m; Power Drift = -0.03 dB
Peak SAR (extrapolated) = 3.65 W/kg
SAR(1 g) = 2.42 W/kg; SAR(10 g) = 1.59 W/kg
Maximum value of SAR (measured) = 3.23 W/kg

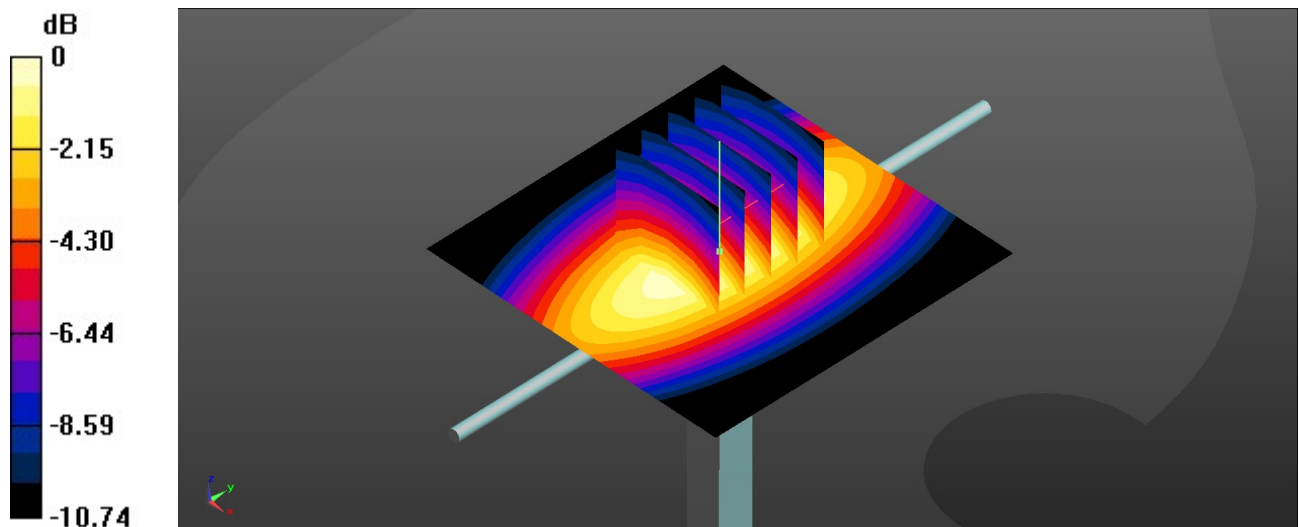

0 dB = 3.23 W/kg

System Check_Head_835MHz

DUT: D835V2-SN:4d162

Communication System: UID 0, CW (0); Frequency: 835 MHz; Duty Cycle: 1:1

Medium: HSL_835_210602 Medium parameters used: $f = 835$ MHz; $\sigma = 0.91$ S/m; $\epsilon_r = 42.91$; $\rho = 1000$ kg/m³

Ambient Temperature : 23.6 °C; Liquid Temperature : 22.6 °C

DASY5 Configuration:

- Probe: EX3DV4 - SN7641; ConvF(10.9, 10.9, 10.9); Calibrated: 2021/3/15
- Sensor-Surface: 1.4mm (Mechanical Surface Detection)
- Electronics: DAE4 Sn1664; Calibrated: 2021/3/1
- Phantom: Twin-SAM V8.0 (Right); Type: QD 000 P41 AA; Serial: 2033
- Measurement SW: DASY52, Version 52.10 (4); SEMCAD X Version 14.6.14 (7483)

Pin=250mW/Area Scan (61x61x1): Interpolated grid: dx=1.500 mm, dy=1.500 mm
Maximum value of SAR (interpolated) = 3.24 W/kg

Pin=250mW/Zoom Scan (5x5x7)/Cube 0: Measurement grid: dx=8mm, dy=8mm, dz=5mm
Reference Value = 62.99 V/m; Power Drift = -0.09 dB
Peak SAR (extrapolated) = 3.62 W/kg
SAR(1 g) = 2.41 W/kg; SAR(10 g) = 1.58 W/kg
Maximum value of SAR (measured) = 3.21 W/kg

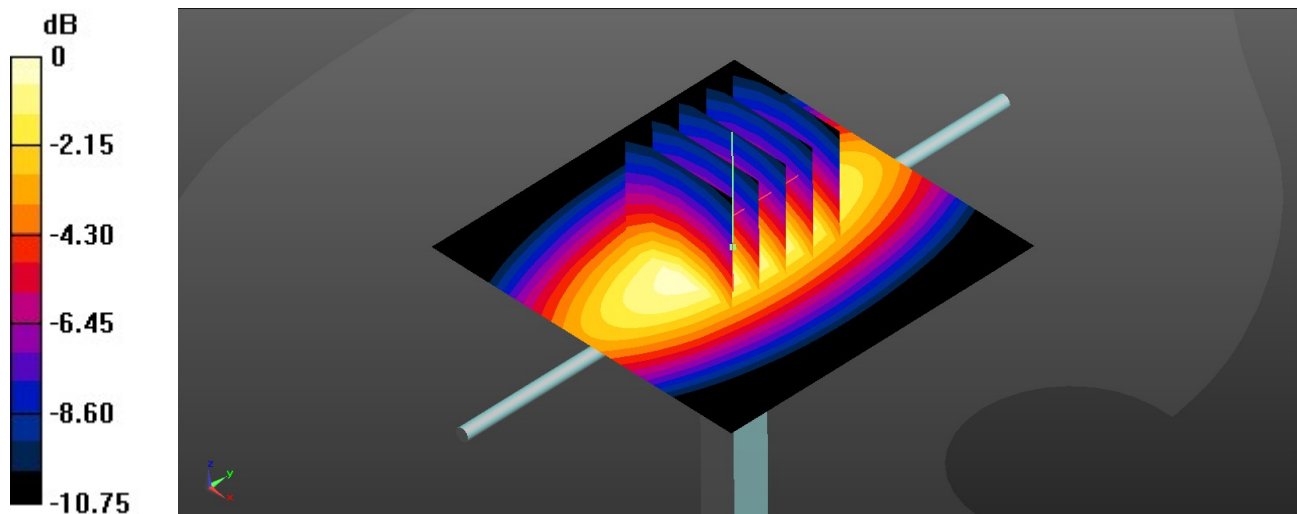

0 dB = 3.21 W/kg

System Check_Head_1750MHz

DUT: D1750V2-SN:1137

Communication System: UID 0, CW; Frequency: 1750 MHz; Duty Cycle: 1:1

Medium: HSL_1750_210520 Medium parameters used: $f = 1750$ MHz; $\sigma = 1.378$ S/m; $\epsilon_r = 41.34$; $\rho = 1000$ kg/m³

Ambient Temperature : 23.6 °C; Liquid Temperature : 22.4 °C

DASY5 Configuration:

- Probe: EX3DV4 - SN7641; ConvF(9.41, 9.41, 9.41); Calibrated: 2021/3/15
- Sensor-Surface: 1.4mm (Mechanical Surface Detection)
- Electronics: DAE4 Sn1664; Calibrated: 2021/3/1
- Phantom: Twin-SAM V8.0 (Right); Type: QD 000 P41 AA; Serial: 2033
- Measurement SW: DASY52, Version 52.10 (4); SEMCAD X Version 14.6.14 (7483)

Pin=250mW/Area Scan (61x61x1): Interpolated grid: dx=1.500 mm, dy=1.500 mm
Maximum value of SAR (interpolated) = 14.2 W/kg

Pin=250mW/Zoom Scan (5x5x7)/Cube 0: Measurement grid: dx=8mm, dy=8mm, dz=5mm

Reference Value = 102.1 V/m; Power Drift = 0.18 dB

Peak SAR (extrapolated) = 17.1 W/kg

SAR(1 g) = 9.13 W/kg; SAR(10 g) = 4.85 W/kg

Maximum value of SAR (measured) = 14.0 W/kg

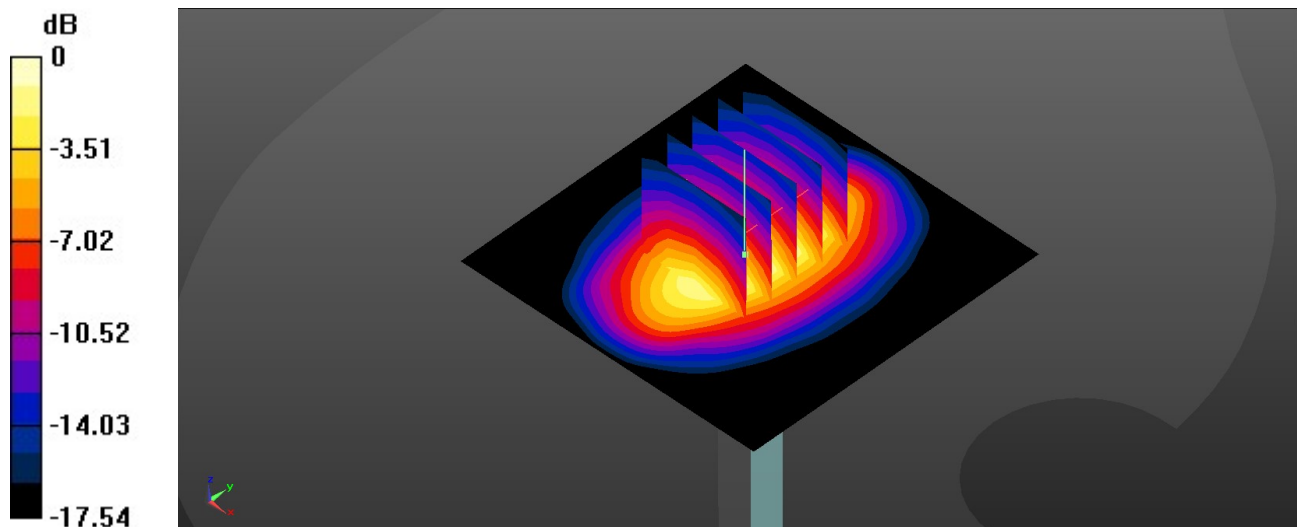

0 dB = 14.0 W/kg

System Check_Head_1750MHz

DUT: D1750V2-SN:1137

Communication System: UID 0, CW; Frequency: 1750 MHz; Duty Cycle: 1:1

Medium: HSL_1750_210604 Medium parameters used: $f = 1750$ MHz; $\sigma = 1.381$ S/m; $\epsilon_r = 40.83$; $\rho = 1000$ kg/m³

Ambient Temperature : 23.5 °C; Liquid Temperature : 22.6 °C

DASY5 Configuration:

- Probe: EX3DV4 - SN7641; ConvF(9.41, 9.41, 9.41); Calibrated: 2021/3/15
- Sensor-Surface: 1.4mm (Mechanical Surface Detection)
- Electronics: DAE4 Sn1664; Calibrated: 2021/3/1
- Phantom: Twin-SAM V8.0 (Right); Type: QD 000 P41 AA; Serial: 2033
- Measurement SW: DASY52, Version 52.10 (4); SEMCAD X Version 14.6.14 (7483)

Pin=250mW/Area Scan (61x61x1): Interpolated grid: dx=1.500 mm, dy=1.500 mm
Maximum value of SAR (interpolated) = 14.2 W/kg

Pin=250mW/Zoom Scan (5x5x7)/Cube 0: Measurement grid: dx=8mm, dy=8mm, dz=5mm
Reference Value = 102.1 V/m; Power Drift = 0.18 dB
Peak SAR (extrapolated) = 17.1 W/kg
SAR(1 g) = 9.15 W/kg; SAR(10 g) = 4.86 W/kg
Maximum value of SAR (measured) = 14.0 W/kg

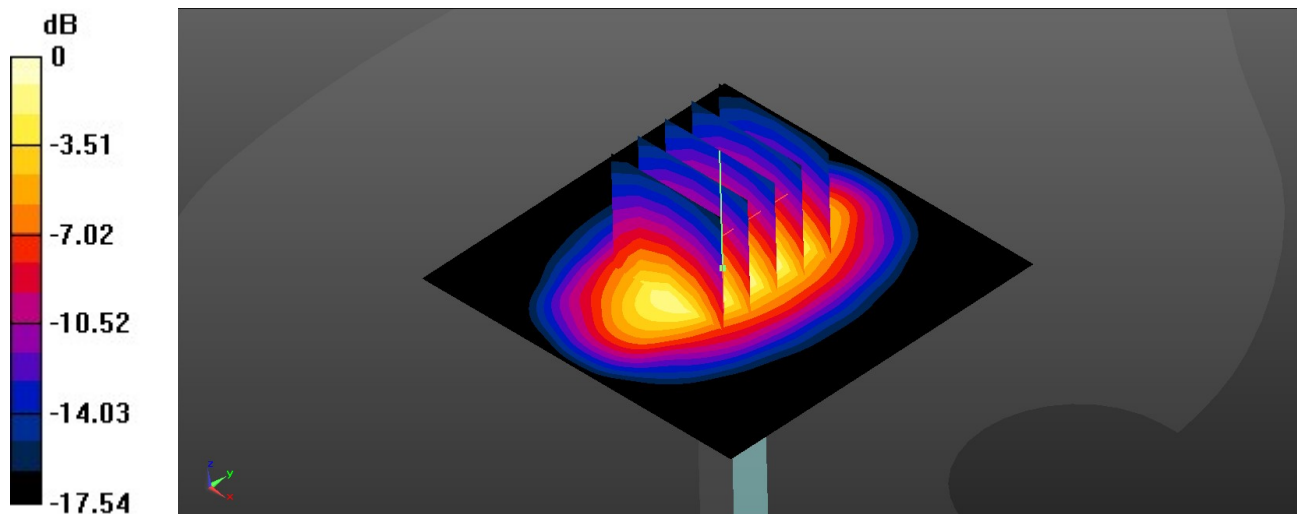

0 dB = 14.0 W/kg

System Check_Head_1900MHz

DUT: D1900V2-SN:5d182

Communication System: UID 0, CW; Frequency: 1900 MHz; Duty Cycle: 1:1

Medium: HSL_1900_210522 Medium parameters used: $f = 1900$ MHz; $\sigma = 1.435$ S/m; $\epsilon_r = 38.464$; $\rho = 1000$ kg/m³

Ambient Temperature : 23.5 °C; Liquid Temperature : 22.7 °C

DASY5 Configuration:

- Probe: EX3DV4 - SN7641; ConvF(9.05, 9.05, 9.05); Calibrated: 2021/3/15
- Sensor-Surface: 1.4mm (Mechanical Surface Detection)
- Electronics: DAE4 Sn1664; Calibrated: 2021/3/1
- Phantom: Twin-SAM V8.0 (Right); Type: QD 000 P41 AA; Serial: 2033
- Measurement SW: DASY52, Version 52.10 (4); SEMCAD X Version 14.6.14 (7483)

Pin=250mW/Area Scan (61x61x1): Interpolated grid: $dx=1.500$ mm, $dy=1.500$ mm
Maximum value of SAR (interpolated) = 16.0 W/kg

Pin=250mW/Zoom Scan (5x5x7)/Cube 0: Measurement grid: $dx=8$ mm, $dy=8$ mm, $dz=5$ mm
Reference Value = 108.6 V/m; Power Drift = -0.01 dB
Peak SAR (extrapolated) = 19.6 W/kg
SAR(1 g) = 9.99 W/kg; SAR(10 g) = 5.06 W/kg
Maximum value of SAR (measured) = 16.0 W/kg

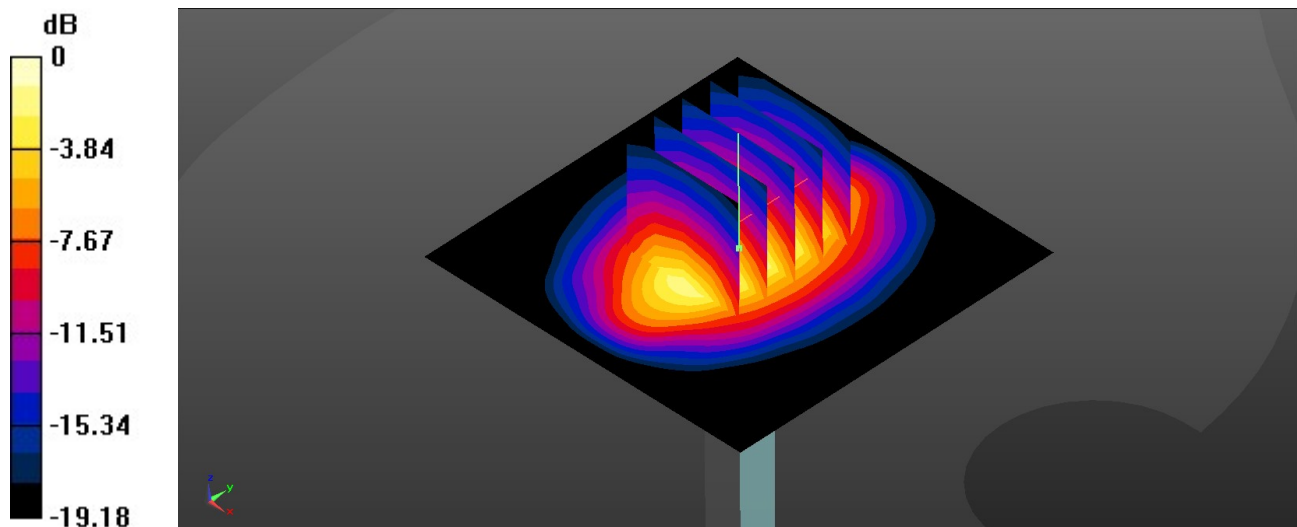

0 dB = 16.0 W/kg

System Check_Head_1900MHz

DUT: D1900V2-SN:5d182

Communication System: UID 0, CW; Frequency: 1900 MHz; Duty Cycle: 1:1

Medium: HSL_1900_210606 Medium parameters used: $f = 1900$ MHz; $\sigma = 1.446$ S/m; $\epsilon_r = 39.09$; $\rho = 1000$ kg/m³

Ambient Temperature : 23.4 °C; Liquid Temperature : 22.4 °C

DASY5 Configuration:

- Probe: EX3DV4 - SN7641; ConvF(9.05, 9.05, 9.05); Calibrated: 2021/3/15
- Sensor-Surface: 1.4mm (Mechanical Surface Detection)
- Electronics: DAE4 Sn1664; Calibrated: 2021/3/1
- Phantom: Twin-SAM V8.0 (Right); Type: QD 000 P41 AA; Serial: 2033
- Measurement SW: DASY52, Version 52.10 (4); SEMCAD X Version 14.6.14 (7483)

Pin=250mW/Area Scan (61x61x1): Interpolated grid: dx=1.500 mm, dy=1.500 mm
Maximum value of SAR (interpolated) = 16.1 W/kg

Pin=250mW/Zoom Scan (5x5x7)/Cube 0: Measurement grid: dx=8mm, dy=8mm, dz=5mm
Reference Value = 108.6 V/m; Power Drift = -0.01 dB
Peak SAR (extrapolated) = 19.7 W/kg
SAR(1 g) = 10.1 W/kg; SAR(10 g) = 5.1 W/kg
Maximum value of SAR (measured) = 16.2 W/kg

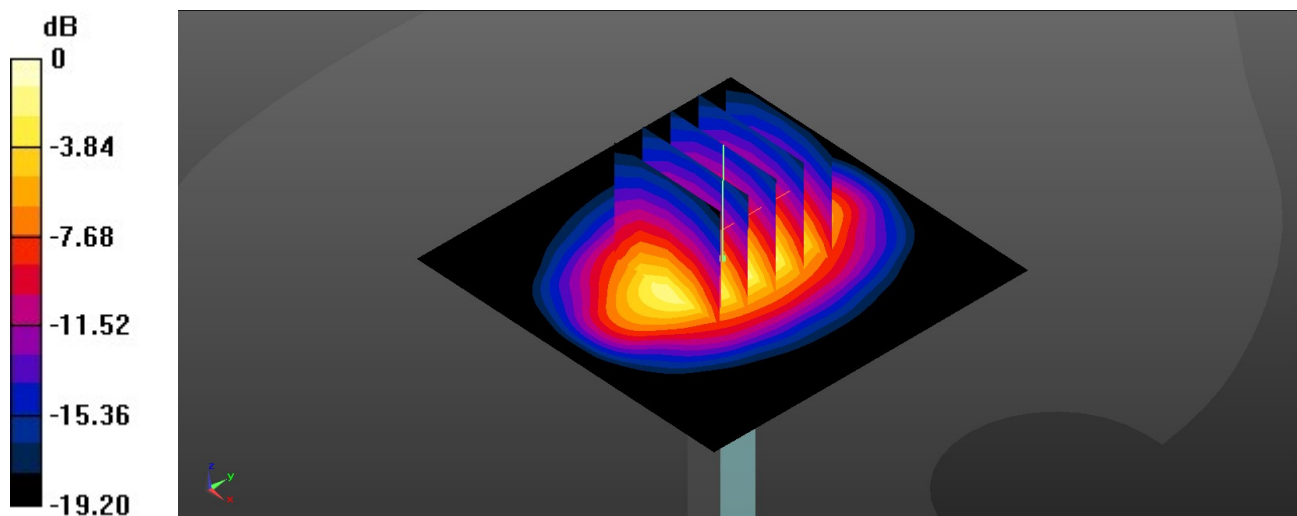

0 dB = 16.2 W/kg

System Check_Head_2450MHz

DUT: D2450V2-SN:924

Communication System: UID 0, CW; Frequency: 2450 MHz; Duty Cycle: 1:1

Medium: HSL_2450_210524 Medium parameters used: $f = 2450$ MHz; $\sigma = 1.834$ S/m; $\epsilon_r = 39.654$; $\rho = 1000$ kg/m³

Ambient Temperature : 23.7 °C; Liquid Temperature : 22.8 °C

DASY5 Configuration:

- Probe: EX3DV4 - SN7641; ConvF(8.29, 8.29, 8.29); Calibrated: 2021/3/15
- Sensor-Surface: 1.4mm (Mechanical Surface Detection)
- Electronics: DAE4 Sn1664; Calibrated: 2021/3/1
- Phantom: Twin-SAM V8.0 (Right); Type: QD 000 P41 AA; Serial: 2033
- Measurement SW: DASY52, Version 52.10 (4); SEMCAD X Version 14.6.14 (7483)

Pin=250mW/Area Scan (81x81x1): Interpolated grid: $dx=1.200$ mm, $dy=1.200$ mm
Maximum value of SAR (interpolated) = 21.4 W/kg

Pin=250mW/Zoom Scan (7x7x7)/Cube 0: Measurement grid: $dx=5$ mm, $dy=5$ mm, $dz=5$ mm
Reference Value = 110.0 V/m; Power Drift = 0.08 dB
Peak SAR (extrapolated) = 27.4 W/kg
SAR(1 g) = 12.1 W/kg; SAR(10 g) = 5.45 W/kg
Maximum value of SAR (measured) = 21.3 W/kg

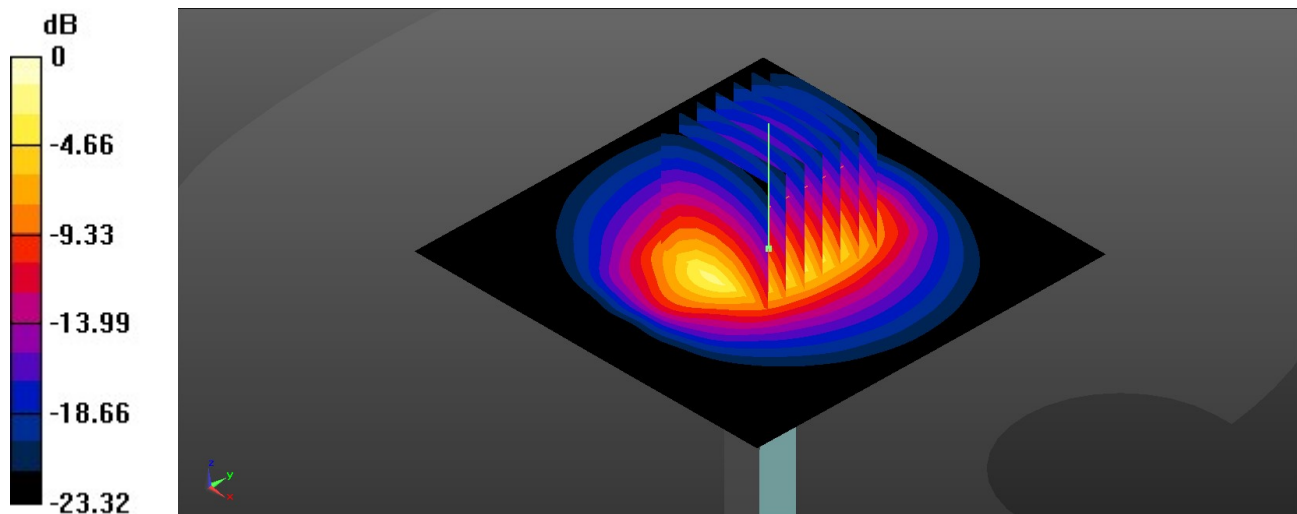

0 dB = 21.3 W/kg

System Check_Head_2450MHz

DUT: D2450V2-SN:924

Communication System: UID 0, CW; Frequency: 2450 MHz; Duty Cycle: 1:1

Medium: HSL_2450_210608 Medium parameters used: $f = 2450$ MHz; $\sigma = 1.824$ S/m; $\epsilon_r = 38.032$; $\rho = 1000$ kg/m³

Ambient Temperature : 23.5 °C; Liquid Temperature : 22.7 °C

DASY5 Configuration:

- Probe: EX3DV4 - SN7641; ConvF(8.29, 8.29, 8.29); Calibrated: 2021/3/15
- Sensor-Surface: 1.4mm (Mechanical Surface Detection)
- Electronics: DAE4 Sn1664; Calibrated: 2021/3/1
- Phantom: Twin-SAM V8.0 (Right); Type: QD 000 P41 AA; Serial: 2033
- Measurement SW: DASY52, Version 52.10 (4); SEMCAD X Version 14.6.14 (7483)

Pin=250mW/Area Scan (81x81x1): Interpolated grid: dx=1.200 mm, dy=1.200 mm
Maximum value of SAR (interpolated) = 21.3 W/kg

Pin=250mW/Zoom Scan (7x7x7)/Cube 0: Measurement grid: dx=5mm, dy=5mm, dz=5mm
Reference Value = 110.0 V/m; Power Drift = 0.06 dB
Peak SAR (extrapolated) = 27.2 W/kg
SAR(1 g) = 12 W/kg; SAR(10 g) = 5.42 W/kg
Maximum value of SAR (measured) = 21.2 W/kg

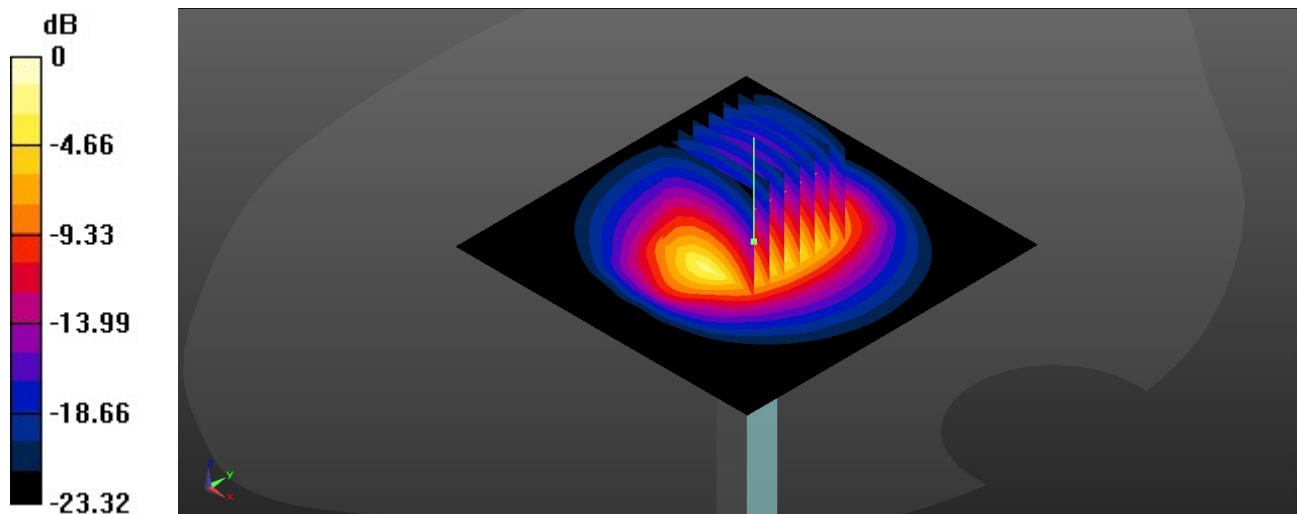

0 dB = 21.2 W/kg

System Check_Head_2600MHz

DUT: D2600V2-SN:1070

Communication System: UID 0, CW (0); Frequency: 2600 MHz; Duty Cycle: 1:1

Medium: HSL_2600_210521 Medium parameters used: $f = 2600$ MHz; $\sigma = 2.056$ S/m; $\epsilon_r = 37.284$; $\rho = 1000$ kg/m³

Ambient Temperature : 23.4 °C; Liquid Temperature : 22.6 °C

DASY5 Configuration:

- Probe: EX3DV4 - SN7641; ConvF(7.94, 7.94, 7.94); Calibrated: 2021/3/15
- Sensor-Surface: 1.4mm (Mechanical Surface Detection)
- Electronics: DAE4 Sn1664; Calibrated: 2021/3/1
- Phantom: Twin-SAM V8.0 (Right); Type: QD 000 P41 AA; Serial: 2033
- Measurement SW: DASY52, Version 52.10 (4); SEMCAD X Version 14.6.14 (7483)

Pin=250mW/Area Scan (71x81x1): Interpolated grid: dx=1.200 mm, dy=1.200 mm
Maximum value of SAR (interpolated) = 25.2 W/kg

Pin=250mW/Zoom Scan (7x7x7)/Cube 0: Measurement grid: dx=5mm, dy=5mm, dz=5mm
Reference Value = 113.5 V/m; Power Drift = 0.02 dB
Peak SAR (extrapolated) = 32.7 W/kg
SAR(1 g) = 14 W/kg; SAR(10 g) = 6.05 W/kg
Maximum value of SAR (measured) = 25.0 W/kg

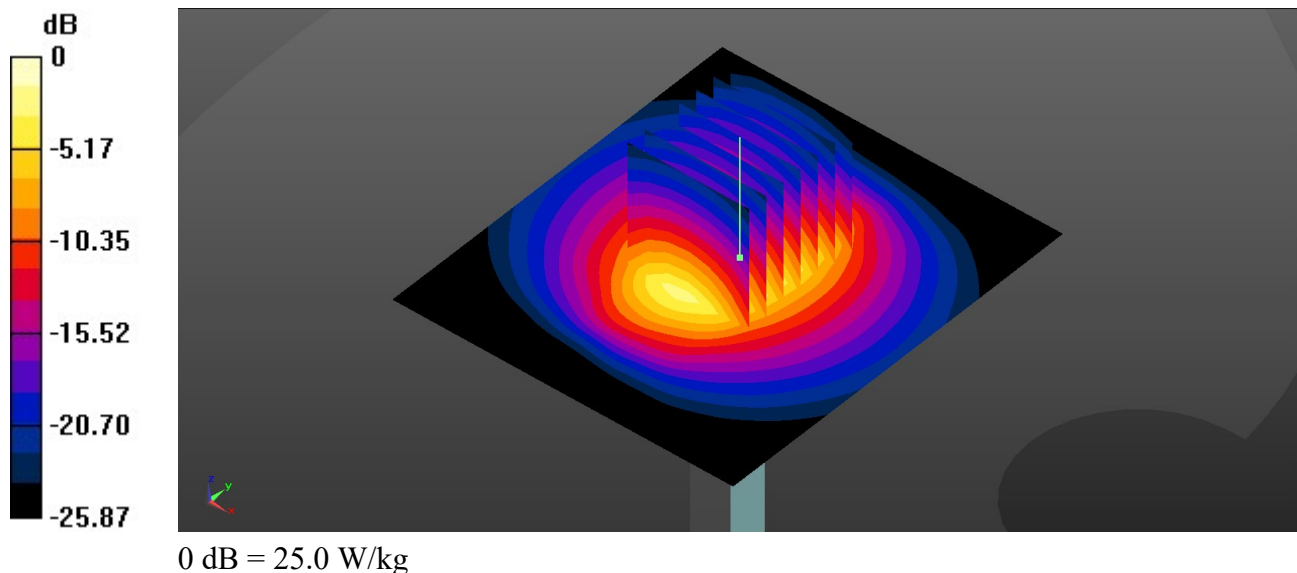

System Check_Head_2600MHz

DUT: D2600V2-SN:1070

Communication System: UID 0, CW (0); Frequency: 2600 MHz; Duty Cycle: 1:1

Medium: HSL_2600_210610 Medium parameters used: $f = 2600$ MHz; $\sigma = 1.894$ S/m; $\epsilon_r = 40.24$; $\rho = 1000$ kg/m³

Ambient Temperature : 23.5 °C; Liquid Temperature : 22.6 °C

DASY5 Configuration:

- Probe: EX3DV4 - SN7641; ConvF(7.94, 7.94, 7.94); Calibrated: 2021/3/15
- Sensor-Surface: 1.4mm (Mechanical Surface Detection)
- Electronics: DAE4 Sn1664; Calibrated: 2021/3/1
- Phantom: Twin-SAM V8.0 (Right); Type: QD 000 P41 AA; Serial: 2033
- Measurement SW: DASY52, Version 52.10 (4); SEMCAD X Version 14.6.14 (7483)

Pin=250mW/Area Scan (71x81x1): Interpolated grid: dx=1.200 mm, dy=1.200 mm
Maximum value of SAR (interpolated) = 23.2 W/kg

Pin=250mW/Zoom Scan (7x7x7)/Cube 0: Measurement grid: dx=5mm, dy=5mm, dz=5mm
Reference Value = 113.5 V/m; Power Drift = 0.02 dB
Peak SAR (extrapolated) = 30.1 W/kg
SAR(1 g) = 14.1 W/kg; SAR(10 g) = 6.08 W/kg
Maximum value of SAR (measured) = 23.1 W/kg

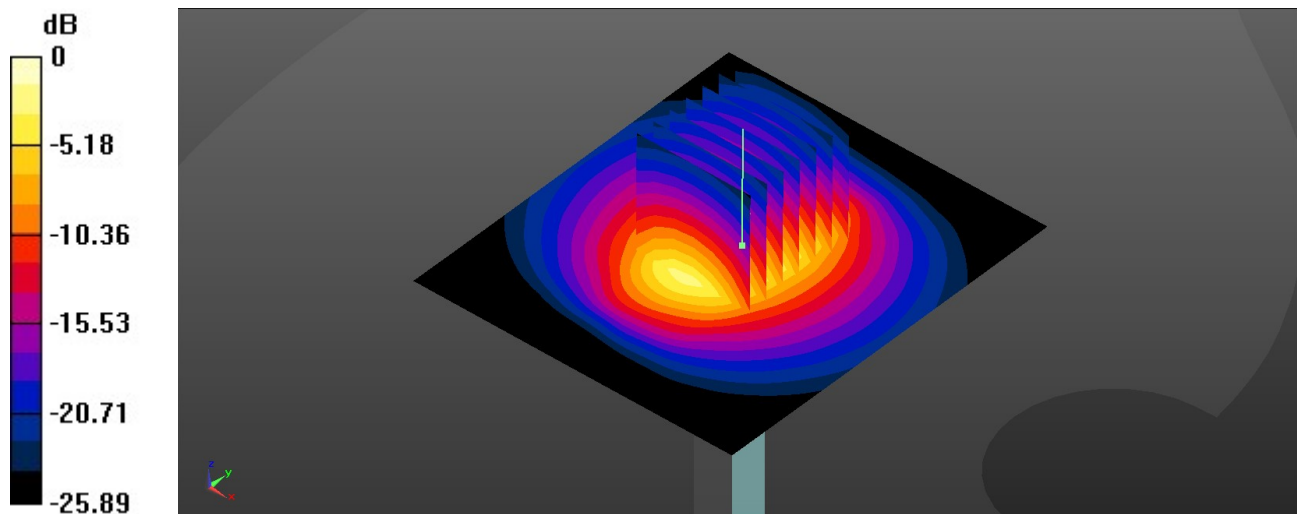

0 dB = 23.1 W/kg

System Check_Head_3500MHz

DUT: D3500V2-SN:1076

Communication System: UID 0, CW (0); Frequency: 3500 MHz; Duty Cycle: 1:1

Medium: HSL_3500_210612 Medium parameters used: $f = 3500$ MHz; $\sigma = 2.862$ S/m; $\epsilon_r = 39.729$; $\rho = 1000$ kg/m³

Ambient Temperature : 23.7 °C; Liquid Temperature : 22.7 °C

DASY5 Configuration:

- Probe: EX3DV4 - SN7641; ConvF(7.4, 7.4, 7.4); Calibrated: 2021/3/15

- Sensor-Surface: 1.4mm (Mechanical Surface Detection)

- Electronics: DAE4 Sn1664; Calibrated: 2021/3/1

- Phantom: Twin-SAM V8.0 (Right); Type: QD 000 P41 AA; Serial: 2033

- Measurement SW: DASY52, Version 52.10 (4); SEMCAD X Version 14.6.14 (7483)

Pin=100mW/Area Scan (61x61x1): Interpolated grid: dx=1.200 mm, dy=1.200 mm

Maximum value of SAR (interpolated) = 6.68 W/kg

Pin=100mW/Zoom Scan (7x7x7)/Cube 0: Measurement grid: dx=5mm, dy=5mm, dz=1.4mm

Reference Value = 48.08 V/m; Power Drift = 0.02 dB

Peak SAR (extrapolated) = 8.83 W/kg

SAR(1 g) = 6.32 W/kg; SAR(10 g) = 2.29 W/kg

Maximum value of SAR (measured) = 6.64 W/kg

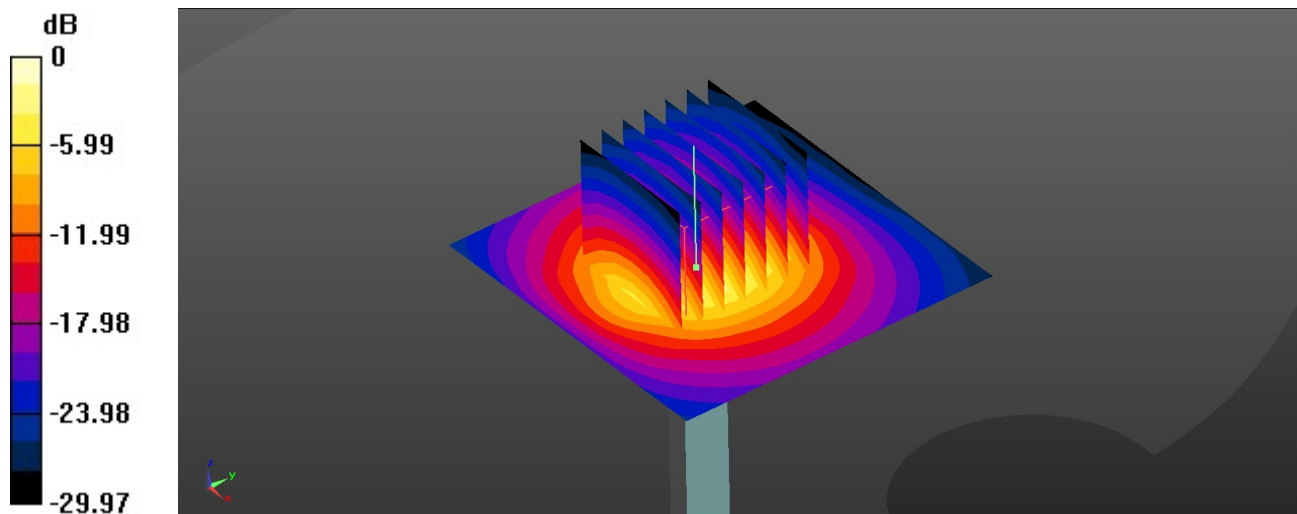

0 dB = 6.64 W/kg

System Check_Head_3500MHz

DUT: D3500V2-SN:1076

Communication System: UID 0, CW (0); Frequency: 3500 MHz; Duty Cycle: 1:1

Medium: HSL_3500_210619 Medium parameters used: $f = 3500$ MHz; $\sigma = 2.941$ S/m; $\epsilon_r = 39.136$; $\rho = 1000$ kg/m³

Ambient Temperature : 23.8 °C; Liquid Temperature : 22.8 °C

DASY5 Configuration:

- Probe: EX3DV4 - SN7641; ConvF(7.4, 7.4, 7.4); Calibrated: 2021/3/15

- Sensor-Surface: 1.4mm (Mechanical Surface Detection)

- Electronics: DAE4 Sn1664; Calibrated: 2021/3/1

- Phantom: Twin-SAM V8.0 (Right); Type: QD 000 P41 AA; Serial: 2033

- Measurement SW: DASY52, Version 52.10 (4); SEMCAD X Version 14.6.14 (7483)

Pin=100mW/Area Scan (61x61x1): Interpolated grid: dx=1.200 mm, dy=1.200 mm

Maximum value of SAR (interpolated) = 6.87 W/kg

Pin=100mW/Zoom Scan (7x7x7)/Cube 0: Measurement grid: dx=5mm, dy=5mm, dz=1.4mm

Reference Value = 48.08 V/m; Power Drift = 0.02 dB

Peak SAR (extrapolated) = 9.08 W/kg

SAR(1 g) = 6.31 W/kg; SAR(10 g) = 2.28 W/kg

Maximum value of SAR (measured) = 6.83 W/kg

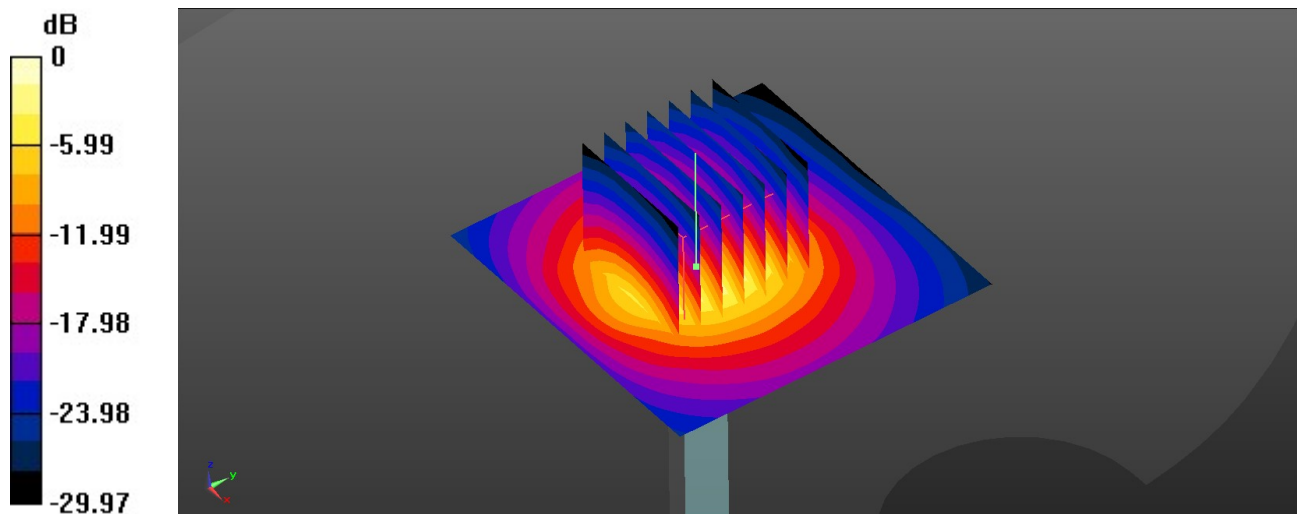

0 dB = 6.83 W/kg

System Check_Head_3700MHz

DUT: D3700V2-SN:1037

Communication System: UID 0, CW (0); Frequency: 3700 MHz; Duty Cycle: 1:1

Medium: HSL_3700_210527 Medium parameters used: $f = 3700$ MHz; $\sigma = 2.967$ S/m; $\epsilon_r = 39.53$; $\rho = 1000$ kg/m³

Ambient Temperature : 23.5 °C; Liquid Temperature : 22.4 °C

DASY5 Configuration:

- Probe: EX3DV4 - SN7641; ConvF(7.2, 7.2, 7.2); Calibrated: 2021/3/15
- Sensor-Surface: 1.4mm (Mechanical Surface Detection)
- Electronics: DAE4 Sn1664; Calibrated: 2021/3/1
- Phantom: Twin-SAM V8.0 (Right); Type: QD 000 P41 AA; Serial: 2033
- Measurement SW: DASY52, Version 52.10 (4); SEMCAD X Version 14.6.14 (7483)

Pin=100mW/Area Scan (61x61x1): Interpolated grid: dx=1.200 mm, dy=1.200 mm
Maximum value of SAR (interpolated) = 13.2 W/kg

Pin=100mW/Zoom Scan (7x7x7)/Cube 0: Measurement grid: dx=5mm, dy=5mm, dz=1.4mm
Reference Value = 69.80 V/m; Power Drift = -0.01 dB
Peak SAR (extrapolated) = 18.1 W/kg
SAR(1 g) = 6.43 W/kg; SAR(10 g) = 2.35 W/kg
Maximum value of SAR (measured) = 13.1 W/kg

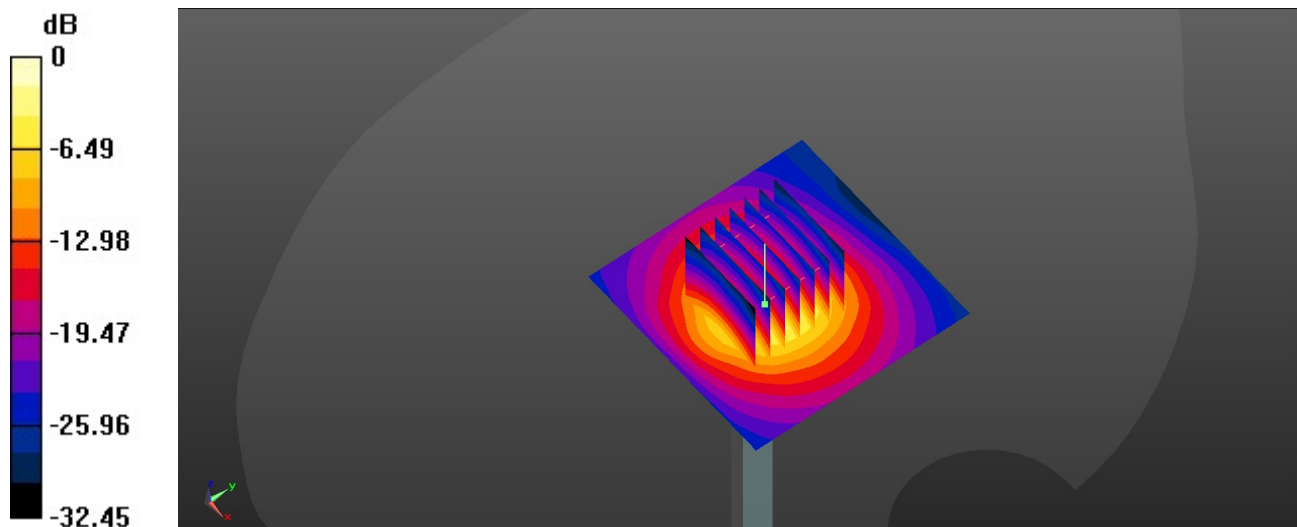

0 dB = 13.1 W/kg

System Check_Head_3700MHz

DUT: D3700V2-SN:1037

Communication System: UID 0, CW (0); Frequency: 3700 MHz; Duty Cycle: 1:1

Medium: HSL_3700_210614 Medium parameters used: $f = 3700$ MHz; $\sigma = 3.042$ S/m; $\epsilon_r = 36.381$; $\rho = 1000$ kg/m³

Ambient Temperature : 23.4 °C; Liquid Temperature : 22.8 °C

DASY5 Configuration:

- Probe: EX3DV4 - SN7641; ConvF(7.2, 7.2, 7.2); Calibrated: 2021/3/15

- Sensor-Surface: 1.4mm (Mechanical Surface Detection)

- Electronics: DAE4 Sn1664; Calibrated: 2021/3/1

- Phantom: Twin-SAM V8.0 (Right); Type: QD 000 P41 AA; Serial: 2033

- Measurement SW: DASY52, Version 52.10 (4); SEMCAD X Version 14.6.14 (7483)

Pin=100mW/Area Scan (61x61x1): Interpolated grid: dx=1.200 mm, dy=1.200 mm

Maximum value of SAR (interpolated) = 11.0 W/kg

Pin=100mW/Zoom Scan (7x7x7)/Cube 0: Measurement grid: dx=5mm, dy=5mm, dz=1.4mm

Reference Value = 63.24 V/m; Power Drift = -0.08 dB

Peak SAR (extrapolated) = 14.7 W/kg

SAR(1 g) = 6.41 W/kg; SAR(10 g) = 2.33 W/kg

Maximum value of SAR (measured) = 10.8 W/kg

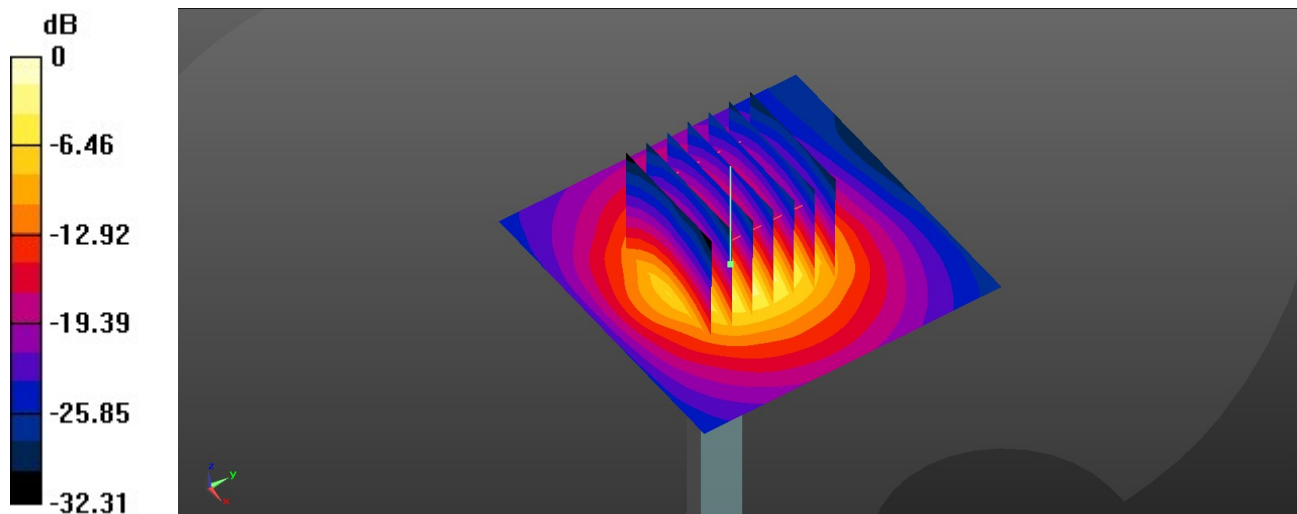

0 dB = 10.8 W/kg

System Check_Head_3900MHz

DUT: D3900V2-SN:1022

Communication System: UID 0, CW (0); Frequency: 3900 MHz; Duty Cycle: 1:1

Medium: HSL_3900_210525 Medium parameters used: $f = 3900$ MHz; $\sigma = 3.226$ S/m; $\epsilon_r = 39.349$; $\rho = 1000$ kg/m³

Ambient Temperature : 23.5 °C; Liquid Temperature : 22.6 °C

DASY5 Configuration:

- Probe: EX3DV4 - SN3819; ConvF(6.48, 6.48, 6.48); Calibrated: 2021/4/30
- Sensor-Surface: 1.4mm (Mechanical Surface Detection)
- Electronics: DAE4 Sn1386; Calibrated: 2021/1/13
- Phantom: SAM (30deg probe tilt) with CRP v4.0; Type: QD000P40CC; Serial: TP: 1500
- Measurement SW: DASY52, Version 52.10 (3); SEMCAD X Version 14.6.14 (7483)

Pin=100mW/Area Scan (61x61x1): Interpolated grid: dx=1.200 mm, dy=1.200 mm
Maximum value of SAR (interpolated) = 13.0 W/kg

Pin=100mW/Zoom Scan (7x7x7)/Cube 0: Measurement grid: dx=5mm, dy=5mm, dz=1.4mm
Reference Value = 67.28 V/m; Power Drift = 0.02 dB
Peak SAR (extrapolated) = 17.8 W/kg
SAR(1 g) = 6.49 W/kg; SAR(10 g) = 2.28 W/kg
Maximum value of SAR (measured) = 13.0 W/kg

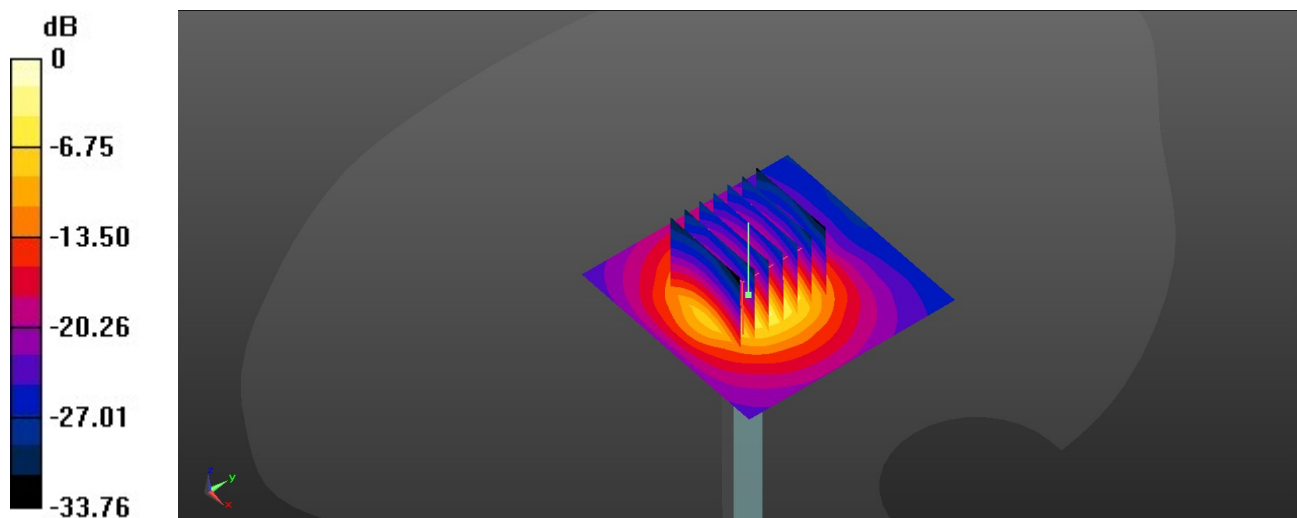

0 dB = 13.0 W/kg

System Check_Head_3900MHz

DUT: D3900V2-SN:1022

Communication System: UID 0, CW (0); Frequency: 3900 MHz; Duty Cycle: 1:1

Medium: HSL_3900_210618 Medium parameters used: $f = 3900$ MHz; $\sigma = 3.233$ S/m; $\epsilon_r = 39.126$; $\rho = 1000$ kg/m³

Ambient Temperature : 23.5 °C; Liquid Temperature : 22.5 °C

DASY5 Configuration:

- Probe: EX3DV4 - SN3819; ConvF(6.48, 6.48, 6.48); Calibrated: 2021/4/30
- Sensor-Surface: 1.4mm (Mechanical Surface Detection)
- Electronics: DAE4 Sn1386; Calibrated: 2021/1/13
- Phantom: SAM (30deg probe tilt) with CRP v4.0; Type: QD000P40CC; Serial: TP: 1500
- Measurement SW: DASY52, Version 52.10 (3); SEMCAD X Version 14.6.14 (7483)

Pin=100mW/Area Scan (61x61x1): Interpolated grid: dx=1.200 mm, dy=1.200 mm
Maximum value of SAR (interpolated) = 13.0 W/kg

Pin=100mW/Zoom Scan (7x7x7)/Cube 0: Measurement grid: dx=5mm, dy=5mm, dz=1.4mm
Reference Value = 67.28 V/m; Power Drift = 0.04 dB
Peak SAR (extrapolated) = 17.8 W/kg
SAR(1 g) = 6.44 W/kg; SAR(10 g) = 2.26 W/kg
Maximum value of SAR (measured) = 12.0 W/kg

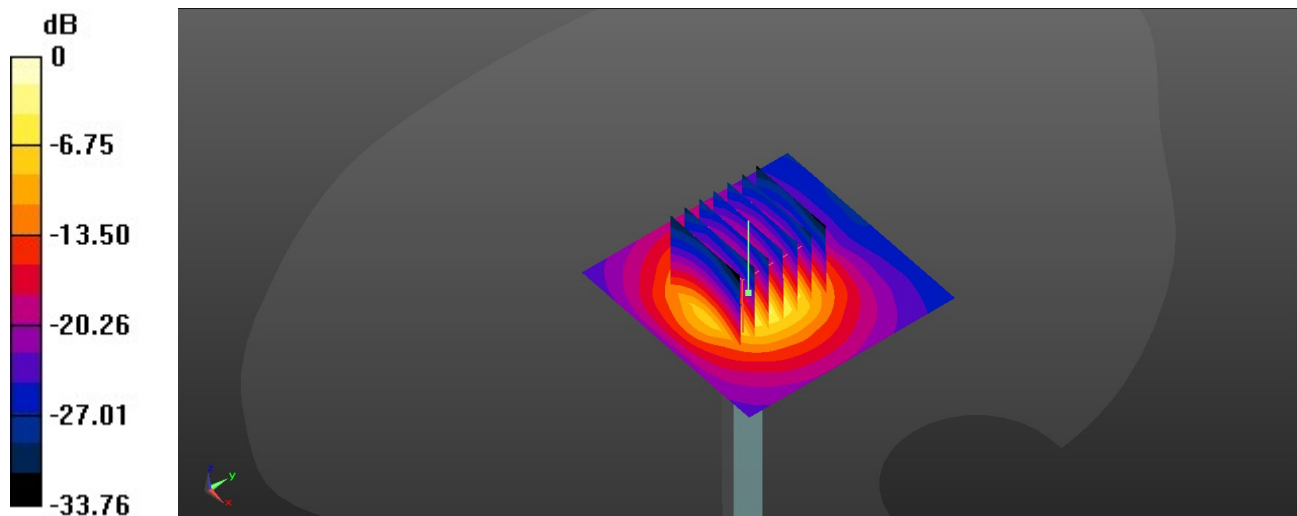

0 dB = 12.0 W/kg

System Check_Head_5250MHz

DUT: D5GHzV2-SN:1167

Communication System: UID 0, CW; Frequency: 5250 MHz; Duty Cycle: 1:1

Medium: HSL_5250_210526 Medium parameters used: $f = 5250$ MHz; $\sigma = 4.714$ S/m; $\epsilon_r = 36.412$; $\rho = 1000$ kg/m³

Ambient Temperature : 23.4 °C; Liquid Temperature : 22.8 °C

DASY5 Configuration:

- Probe: EX3DV4 - SN7641; ConvF(5.68, 5.68, 5.68); Calibrated: 2020/11/30
- Sensor-Surface: 1.4mm (Mechanical Surface Detection)
- Electronics: DAE4 Sn1664; Calibrated: 2021/1/13
- Phantom: Twin-SAM V8.0 (Right); Type: QD 000 P41 AA; Serial: 2033
- Measurement SW: DASY52, Version 52.10 (4); SEMCAD X Version 14.6.14 (7483)

Pin=100mW/Area Scan (71x71x1): Interpolated grid: dx=1.000 mm, dy=1.000 mm
Maximum value of SAR (interpolated) = 20.3 W/kg

Pin=100mW/Zoom Scan (7x7x7)/Cube 0: Measurement grid: dx=4mm, dy=4mm, dz=1.4mm
Reference Value = 75.09 V/m; Power Drift = -0.11 dB
Peak SAR (extrapolated) = 33.7 W/kg
SAR(1 g) = 8.27 W/kg; SAR(10 g) = 2.28 W/kg
Maximum value of SAR (measured) = 20.5 W/kg

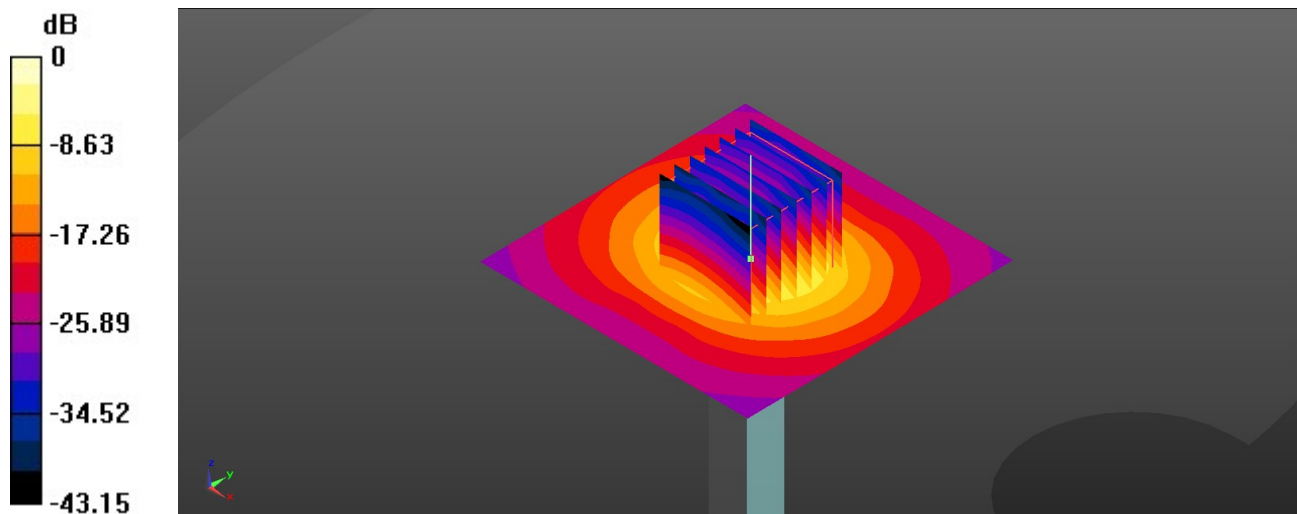

0 dB = 20.5 W/kg